

Esquema de Montagem

Assembly Instructions / Instruções de Montaje

TOCCARE
BY VAMOL

vamol
Indústria Moveleira

HOME TOPAZIO

REF.:07000148 Canyon/Preto - Canyon/Black
REF.:07000149 Atacama/Preto - Atacama/Black
REF.:07000160 Canyon/Branco - Canyon/White
REF.:07000161 Atacama/Branco - Atacama/White
REF.:07000178 Celtic/Preto - Celtic/Black
REF.:07000179 Celtic/Branco - Celtic/White

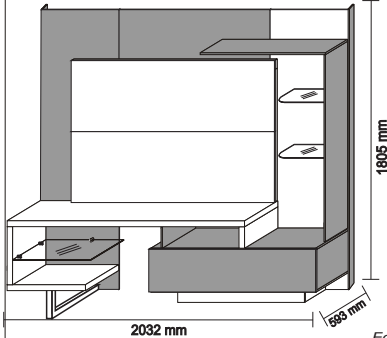

Caro Montador:
Para uma melhor montagem de nosso produto, siga as seguintes instruções:
* O Móvel deve ser montado deitado com a frente para cima.
* Separe as peças e acessórios.
* Encaixe as cavilhas.
* Parafuse os pinos de Girofix.
Após o encaixe das peças e fixação dos parafusos, o móvel deve ser levantado:
* Os fundos deverão ser pregados observando o esquadro do Móvel.
Deixe as portas e prateleiras removíveis para serem encaixadas e reguladas por último.

Dear Editor:
For a better assembly of our product, follow these instructions:
* The Mobile should be mounted lying face-up.
* Separate the parts and accessories.
* Insert the bolts.
* Screw pins Girofix.
After seating of the parts and fixing screws, the furniture should be lifted:
* The fund should be nailed to the square of the observing Mobile.
Leave the doors and removable shelves to be fitted and adjusted last

Sr. Director:
Para un conjunto mejor de nuestro producto, siga estas instrucciones:
* El móvil debe ser montado acostado boca arriba.
* Separe las partes y accesorios.
* Introducir los tornillos.
* El cable Girofix pins.
Después de asientos de las piezas y tornillos de fijación, los muebles deben ser levantados:
* El fondo debe ser clavado en la plaza de los móviles de observación.
Deje las puertas y estantes extraíbles para montar y ajustar los últimos



A	500233 48un. Cavilha de Madeira 8 x 30 Tarugo de madeira Wood Dowel	B	500232 30un. Castanha do Girofix Girofix	C	501060 01un. TOCCARE Etiqueta Logo Logo	D	500256 30un. Pino do Girofix Tornillo del Girofix Girofix Pin	E	500857 02un. Corrediza Telescópica 400mm Metal Slide Metal Slide
F	500267-08 08un. Sapata Redonda Zapato Ronda Shoe Round	G	500523 09un. Suporte prateleira 'U' Soporte de estante Support shelf	H	500231 17un. Cantoneira de Metal 4 furos Soporte metálico Metal bracket	I	500258 35un. Prego 10 x 10 Clavo Nail	J	500975 01un. Pé de Alumínio Pie Alumínio Foot Aluminium
K	500966 01un. Vidro 450 x 420 x 5 Vidrio Shelf	L	500974 02un. Vidro 400 x 245 x 5 Vidrio Shelf	M	500520 08un. Chapinha de Metal Chapa de Metal Sheet metal	S	500273 08un. Tampa do Girofix Cubre Girofix Cover Girofix	T	500281 10un. Tampa Furo 15 mm Tapa Hole
U	500521 01un. Passa fio 60 mm Pase alambre Pass wire	V	500236 01un. Cola Sachê Cole Glue	W	500960 06un. Tampa Furo 18 mm Tapa Hole				

Esquema Atualizado
02/04/2013

Revisão Nº
04

Exemplo
Cód da peça.
070001 + 01
Cód do produto.

Ferragens Tamanho Real / Tamaño Real / Real Size

N	500247		Parafuso 3,5 x 12 Panela Tornillo/Screw	124un.
O	500249		Parafuso 3,5 x 25 Chata Tornillo/Screw	04un.
P	500251		Parafuso 3,5 x 30 Chata Tornillo/Screw	10un.
Q	500255		Parafuso 5,0 x 50 Estrutural Tornillo/Screw	17un.
R	500959		Parafuso 3,5 x 35 Chata Tornillo/Screw	19un.

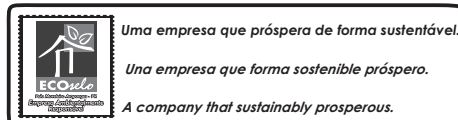

Qualquer problema, favor informar o Nº de Lote contido no Manual de Instruções dos Produtos Vamol

Cualquier problema, por favor proporcione el número de lote que figuran en el Manual de Instrucción de la Vamol productos / Any problem, please provide the lot number contained in the Instruction Manual of the products Vamol

Rod. Pr444 - KM 08 Saída p/ Mandaguari

Fone/Fax: +55(043)3276-9700

CEP: 86703-990 PR - Brasil

Serviço de atendimento ao consumidor: e-mail: sac@vamol.com.br
site: http://www.vamol.com.br

Cód.Pç	Descrição	Descripción	Description	Qtde	Volume	MateriaPrima	Medida
01	BASE GAVETEIRO	BASE CAJON	BASE DRAWER	01	03	MDP 15(mm)	1200X500
02	RODAPÉ LAT. ESQ.	PIE LATERAL IZQUIERDO	LEFT SIDE FOOTER	01	02	BP 15(mm)	450X90
03	RODAPÉ LAT. DIR.	PIE LATERAL DERECHO	RIGHT SIDE FOOTER	01	02	BP 15(mm)	450X90
04	RODAPÉ FRONTAL	PIE FRONTAL	FOOTER FRONTAL	01	02	BP 15(mm)	970X90
05	LAT. ESQ.GAVETEIRO	LATERAL IZQ. DEL CAJON	DRAWER SIDE LEFT	01	03	MDP 15(mm)	270X449
06	DIV. CENT. GAVETEIRO	DIVISION CENT. CAJON	DIVISION CENT. DRAWER	01	03	MDP 15(mm)	270X449
07	LAT. DIR. GAVETEIRO	LATERAL DER.DEL CAJON	DRAWER SIDE RIGHT	01	03	MDP 15(mm)	270X449
08	TAMPO GAVETEIRO	TAMPO CAJON	DRAWER SURFACE	01	03	MDP 15(mm)	1200X500
09	LAT.INFERIOR.DIR	LAT.INFERIOR DERECHA	LOWER RIGHT SIDE	01	02	BP 45(mm)	177X448
10	DIVISÃO DVD	DIVISION DVD	DIVISION DVD	01	03	MDP 15(mm)	167X360
11	TAMPO TV	TAMPO TV	TAMPO TV	01	02	BP 45(mm)	1602X442
12	COSTA ESQUERDA	FONDO IZQUIERDO	LEFT FUND	01	03	MDP 15(mm)	1800X540
13	LAT.INFERIOR.ESQ	LAT.INFERIOR IZQUIERDO	LOWER LEFT SIDE	01	01	BP 45(mm)	315X438
14	BASE ESQUERDA	BASE IZQUIERDA	BASE LEFT	01	01	BP 45(mm)	532X442
15	COSTA DIREITA	FONDO DERECHA	FUND RIGHT	01	02	BP 15(mm)	1800X540
16	COSTA CENTRAL	FONDO CENTRAL	FUND CENTRAL	01	03	MDP 15(mm)	980X340
17	LATERAL DIR.	LATERAL DERECHA	RIGHT SIDE	01	03	MDP 25(mm)	1113X253
18	COSTA INF. TV	FONDO INF. TV	FUND BOTTON TV	01	01	BP 15(mm)	1360X450
19	COSTA SUP. TV	FONDO SUP. TV	FUND SIDE TOP TV	01	01	BP 15(mm)	1360X450
20	QUADRO LAT./ PAINEL	MARCO LAT./ PAINEL	FRAME SID/PANEL	02	01	MDF 25(mm)	900X50
21	QUADRO SUP. PAINEL	MARCO SUP. PAINEL	FRAME TOP PANEL	01	02	MDF 25(mm)	1258X50
22	PRATELEIRA	PRATELEIRA	SHELF	01	03	MDP 25(mm)	900X255
23	VISTA TRAZEIRA	VISTA TRAZEIRA	REAR FRAME	02	03	MDF 15(mm)	1800X60
24	LAT.ESQ.GAVETA	LAT.ESQ.GAVETA	DRAWER LEFT SIDE	02	03	MDP 15(mm)	400X120
25	CONTRA FUNDO	CONTRA FUNDO	FUND OF THE DRAWER	02	03	MDP 15(mm)	520X100
26	LAT.DIR.GAVETA	LAT.DIR.GAVETA	DRAWER RIGHT SIDE	02	03	MDP 15(mm)	400X120
27	FRENTE GAVETA	FRENTE DEL CAJÓN	FRENTE GAVETA	01	03	MDP 15(mm)	1198X303
28	FUNDO GAVETA	FONDO CAJÓN	DRAWER FRONT	02	03	MDF 03(mm)	535X405
29	FUNDO GAVETEIRO	FONDO CAJÓN	UPPER DRAWER	01	03	MDF 03(mm)	660X297
47	QUADRO INF. PAINEL	MARCO INF. PAINEL	FRAME BOTTIM PANEL	01	02	MDF 25(mm)	1258X50

1º Passo

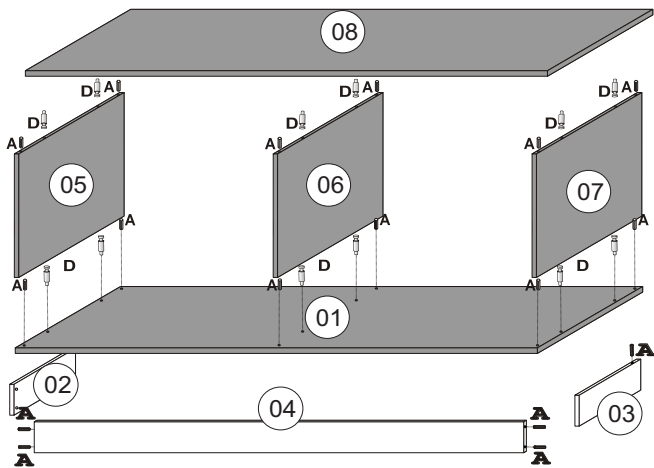

2º Passo

Fixação dos Rodapés

Pies de fijación
Fixation footers

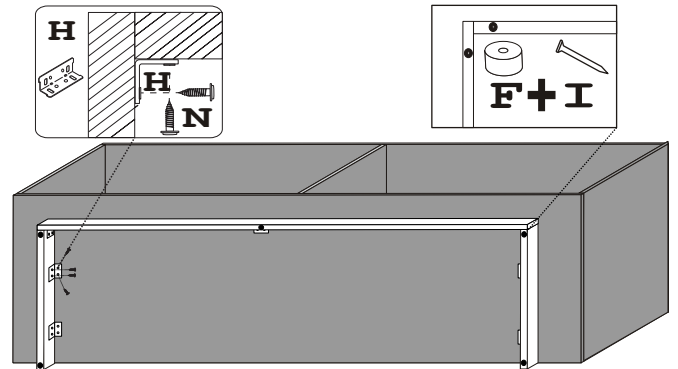

3º Passo

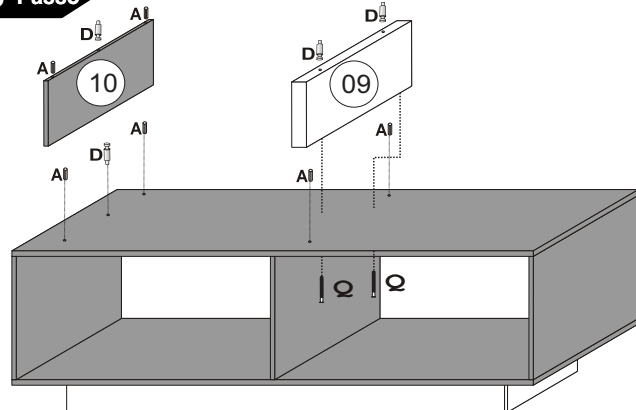

4º Passo

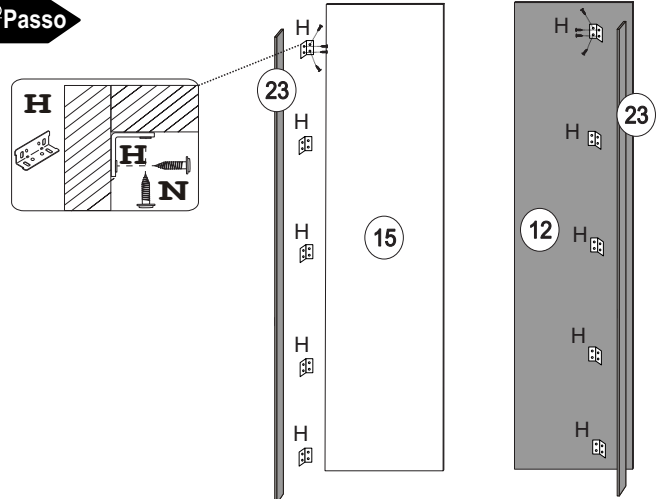

5º Passo

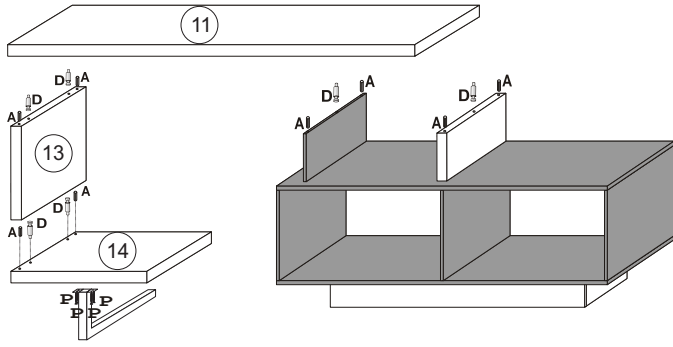

6º Passo

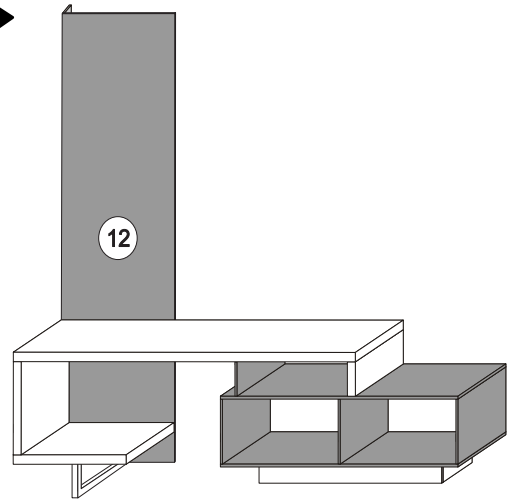

7º Passo

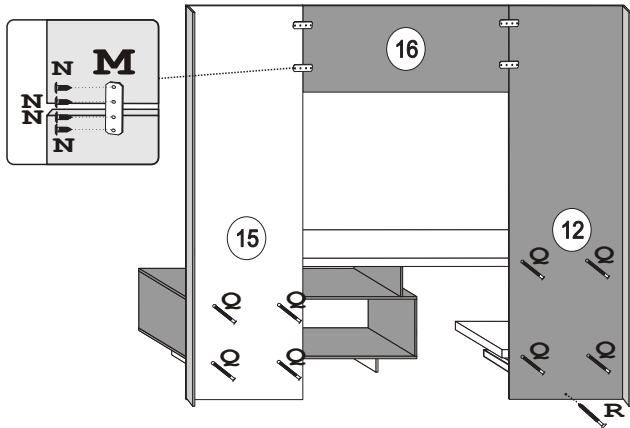

8º Passo

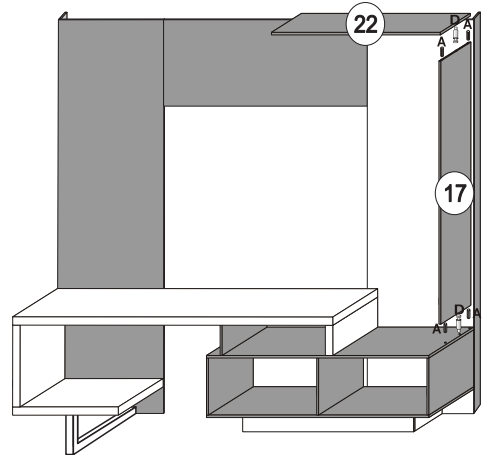

9º Passo

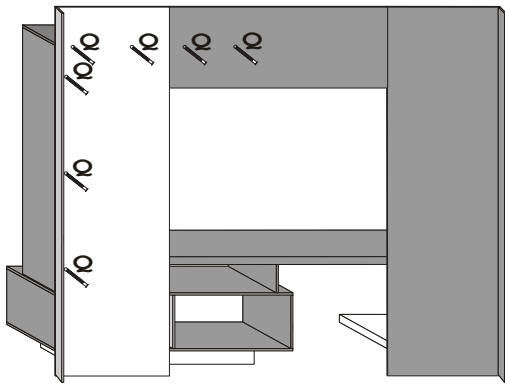

10º Passo

Usar cola nas peças 20 - 21 e 47
 Utilice cole in las partes 20 - 21 e 47
 use glue at the parts 20 - 21 e 47

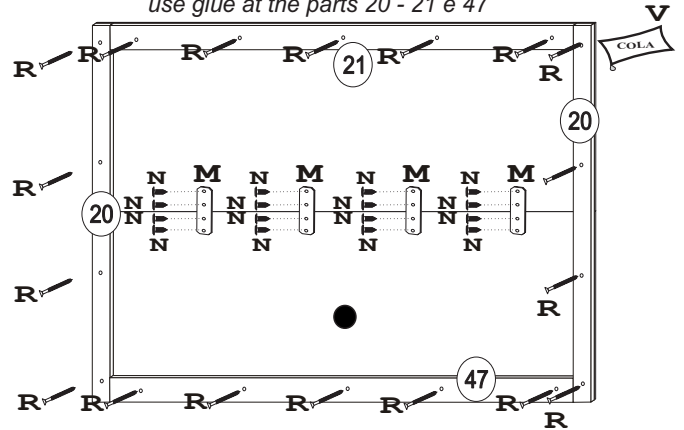

11º Passo

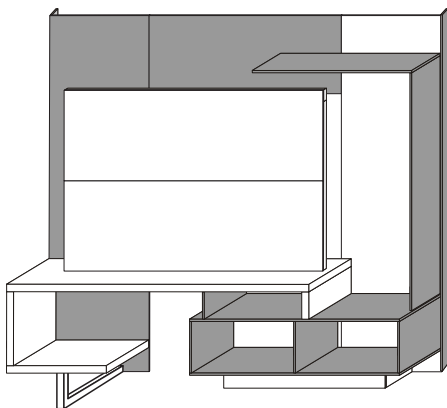

12º Passo

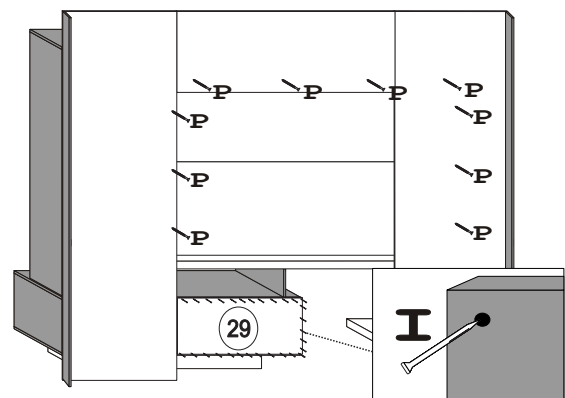

15º Passo

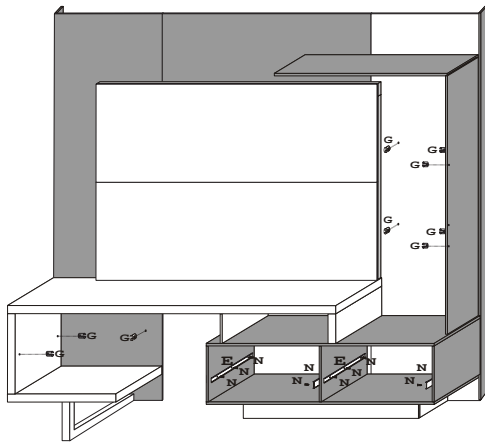

16º Passo

Montagem da Gaveta
Cajón de montaje
Mounting Drawer

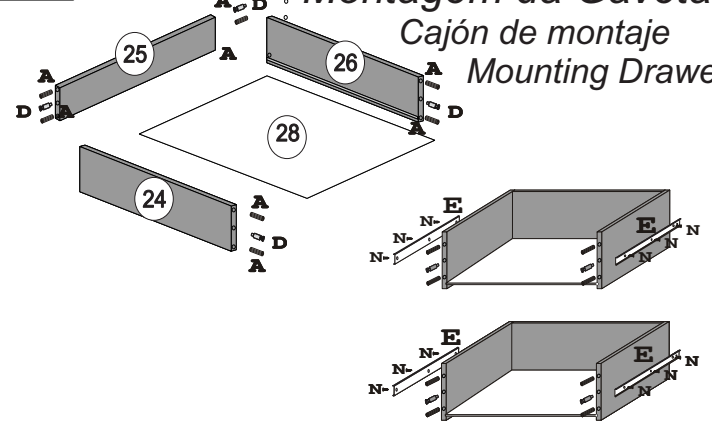

17º Passo

Montagem da Gaveta
Cajón de montaje
Mounting Drawer

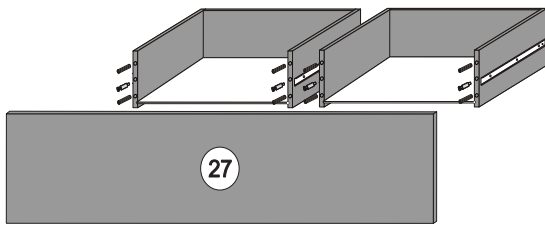

Peso máximo por espaço;
Peso máximo para el espacio;
Maximum weight for space;

Peso máximo para el espacio;
Maximum weight for space;

