

**toke**  
BY VAMOL

## Home Susp Conceito

REF.:030026 169 - Rijo  
REF.:030026 170 - Champagne  
REF.:030026 171 - Petroleo  
REF.:030026 172 - Rijo/Petroleo  
REF.:030026 173 - Rijo/Champagne

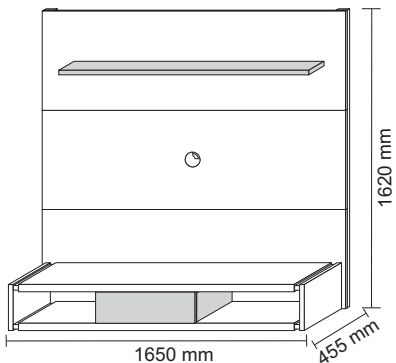

Caro Montador:  
Para uma melhor montagem de nosso produto, siga as seguintes instruções:  
\* O Móvel deve ser montado deitado com a frente para cima.  
\* Separe as peças e acessórios.  
\* Encaixe as cavilhas.  
\* Parafuse os pinos de Girofix.  
Após o encaixe das peças e fixação dos parafusos, o móvel deve ser levantado:  
\* Os fundos deverão ser pregados observando o esquadro do Móvel.  
Deixe as portas e prateleiras removíveis para serem encaixadas e reguladas por último.

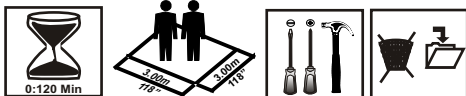

<b>A</b> 500233 18un. Cavilha de Madeira 8 x 30 Tarugo de madeira Wood Dowel	<b>B</b> 500256 18un. Pino do Girofix Tornillo del Girofix Girofix Pin	<b>C</b> 500247 44un. Parafuso 3,5 x 12 Panela Tornillo/Screw	<b>D</b> 500959 23un. Parafuso 3,5 x 35 Chato Tornillo/Screw	<b>E</b> 501644 08un. Parafuso 3,5 x 45 Chato Tornillo/Screw
<b>F</b> 500828 11un. Parafuso 5,0 x 60 Chato Tornillo/Screw	<b>G</b> 500255 12un. Parafuso 5,0 x 50 Estrutural Tarugo de madeira Wood Dowel	<b>H</b> 500258 06un. Prego 10 x 10 Clavo Nail	<b>I</b> 500520 08un. Chapinha de Metal Chapa de Metal Sheet metal	<b>J</b> 500505 08un. Cavilha de Madeira 8 x 50 Tarugo de madeira Wood Dowel
<b>K</b> 501509 11un. Bucha 8 MM	<b>L</b> 500587 06un. Fita Dupla Face Logo	<b>M</b> 500855 01un. Corredija Telescopica 300mm Metal Slide	<b>N</b> 500236 02un. Cola Sachet Glue	<b>O</b> 500232 18un. Castanha do Girofix Girofix
<b>P</b> 500273 01un. Etiqueta Logo Logo	<b>Q</b> 502112 01un. Espelho 507 x 70 x 3 espejo / mirror	<b>R</b> 500273 02un. Tampa do Girofix Cubre Girofix Cover Girofix	<b>S</b> 500521 01un. Passa fio 60 mm Pase alambre Pass wire	

## Esquema de Montagem

Assembly Instructions / Instruccion de Montaje

Dear Editor:  
For a better assembly of our product, follow these instructions:  
\* The Mobile should be mounted lying face-up.  
\* Separate the parts and accessories.  
\* Insert the bolts.  
\* Screw pins Girofix.

Sr. Director:  
Para un conjunto mejor de nuestro producto, siga estas instrucciones:  
\* El móvil debe ser montado acostado boca arriba.  
\* Separe las partes y accesorios.  
\* Introducir los tornillos.  
\* El cable Girofix pins.

After seating of the parts and fixing screws, the furniture should be lifted:  
\* The fund should be nailed to the square of the observing Mobile.  
Leave the doors and removable shelves to be fitted and adjusted last

Después de asientos de las piezas y tornillos de fijación, los muebles deben ser levantadas:  
\* El fondo debe ser clavado en la plaza de los móviles de observación.  
Deje las puertas y estantes extraíbles para montar y ajustar los últimos

Cód.	Descrição	Descripción	Description	Qtd.	Volume	Mat. Prima	Medida
01	BASE BANCADA.	BASE BANCADA.	BASE BANCADA.	01	02	MDP 40MM	1,500x0,355
02	LAT. ESQ. A1.	LAT. ESQ. A1.	LAT. ESQ. A1.	01	03	MDP 15MM	0,170x0,335
03	LAT. DIR. B2.	LAT. DIR. B2.	LAT. DIR. B2.	01	03	MDP 15MM	0,170x0,355
04	VISTA SUP.	VISTA SUP.	VISTA SUP.	01	03	MDP 15MM	0,507x0,070
05	TAMPO BANCADA.	TAMPO BANCADA.	TAMPO BANCADA.	01	02	MDP 40MM	1,500x0,359
06	DETALHE LAT.	DETALHE LAT.	DETALHE LAT.	02	01	MDF 25MM	0,345x0,030
07	LAT. ESQ. A1.	LAT. ESQ. A1.	LAT. ESQ. A1.	01	01	MDP 25MM	0,250x0,355
08	LAT. DIR. B2.	LAT. DIR. B2.	LAT. DIR. B2.	01	01	MDP 25MM	0,250x0,355
09	PAINEL INT. TV. A1.	PAINEL INT. TV. A1.	PAINEL INT. TV. A1.	01	01	MDP 15MM	1,650x0,540
10	PAINEL CENTRAL TV.	PAINEL CENTRAL TV.	PAINEL CENTRAL TV.	01	01	MDP 15MM	1,650x0,540
11	PAINEL SUP. TV B2.	PAINEL SUP. TV B2.	PAINEL SUP. TV B2.	01	01	MDP 15MM	1,650x0,540
12	VISTA TRAS. LAT.	VISTA TRAS. LAT.	VISTA TRAS. LAT.	02	01	MDF 25MM	1,620x0,060
13	PRATELEIRA SUP.	PRATELEIRA SUP.	PRATELEIRA SUP.	01	04	MDP 25MM	1,360x0,145
14	SARRAFO CHANFRADO.	SARRAFO CHANFRADO.	SARRAFO CHANFRADO.	02	04	MDF 25MM	1,500x0,060
15	GABARITO.	GABARITO.	GABARITO.	01	01	MDP 15MM	1,200x0,060
16	SARRAFO CHANF. MENOR.	SARRAFO CHANF. MENOR.	SARRAFO CHANF. MENOR.	04	01	MDF 25MM	0,600x0,060
17	FRENTE GAVETA.	FRENTE GAVETA.	FRENTE GAVETA.	01	04	MDP 15MM	0,540x0,170
18	LAT. ESQ. GAV. A1.	LAT. ESQ. GAV. A1.	LAT. ESQ. GAV. A1.	01	03	MDP 15MM	0,300x0,120
19	LAT. DIR. GAV. B2.	LAT. DIR. GAV. B2.	LAT. DIR. GAV. B2.	01	03	MDP 15MM	0,300x0,120
20	CONTRA FUNDO.	CONTRA FUNDO.	CONTRA FUNDO.	01	03	MDP 15MM	0,450x0,100
21	FUNDO GAVETA.	FUNDO GAVETA.	FUNDO GAVETA.	01	03	MDF 03MM	0,460x0,307

## Ferragens Tamanho Real

Tamaño Real / Real Size

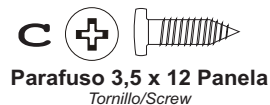
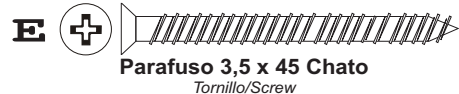

Exemplo

Cód da peça.

030026+ 01

Cód do produto.

Esquema Atualizado  
22/01/2015

Revisão N<sup>o</sup>  
00

Qualquer problema, favor informar o N<sup>o</sup> de Lote contido no Manual de Instruções dos Produtos Vamol

Cualquier problema, por favor proporcione el número de lote que figuran en el Manual de Instrucción de la Vamol productos / Any problem, please provide the lot number contained in the Instruction Manual of the products Vamol

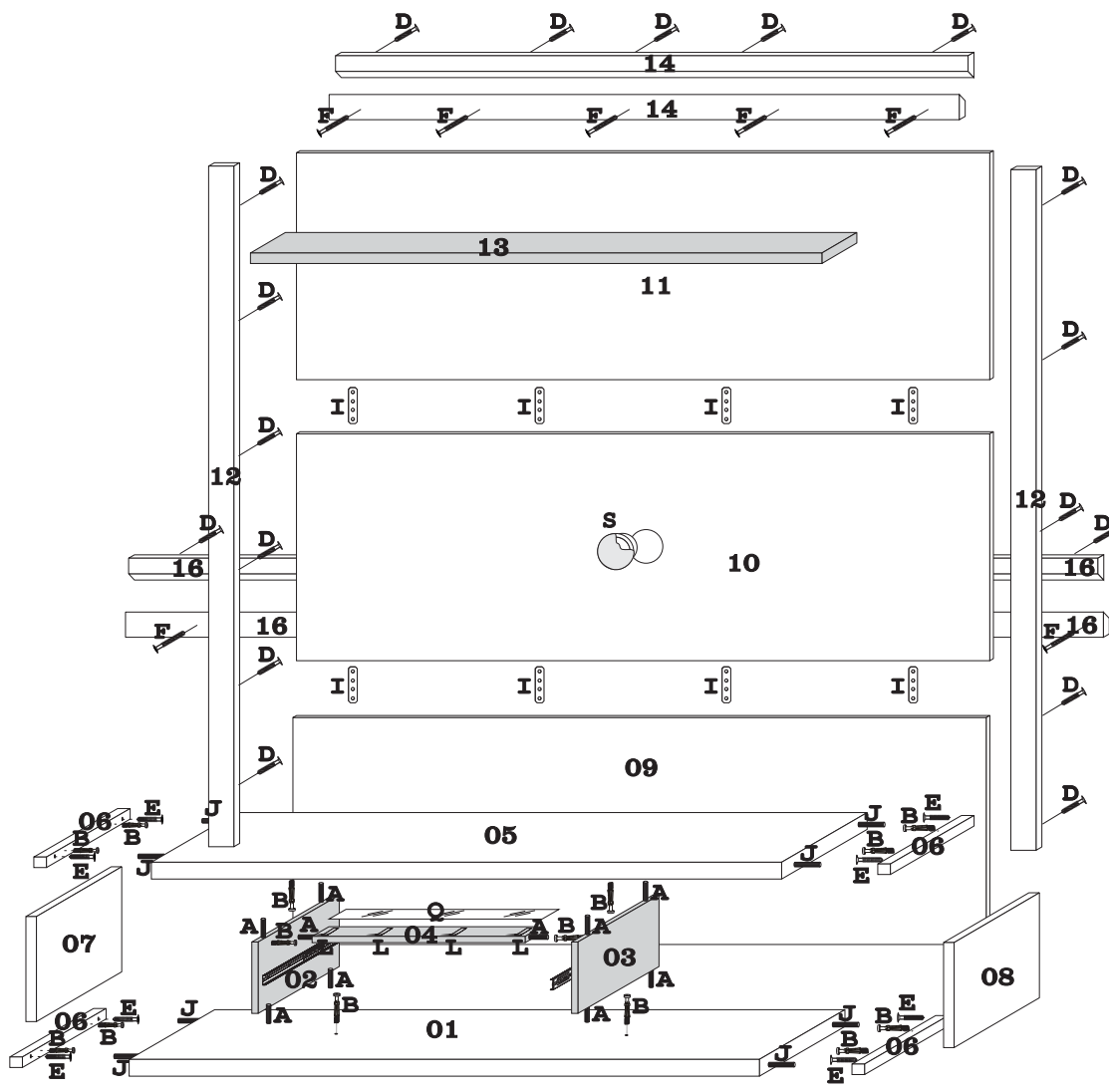

1º Passo

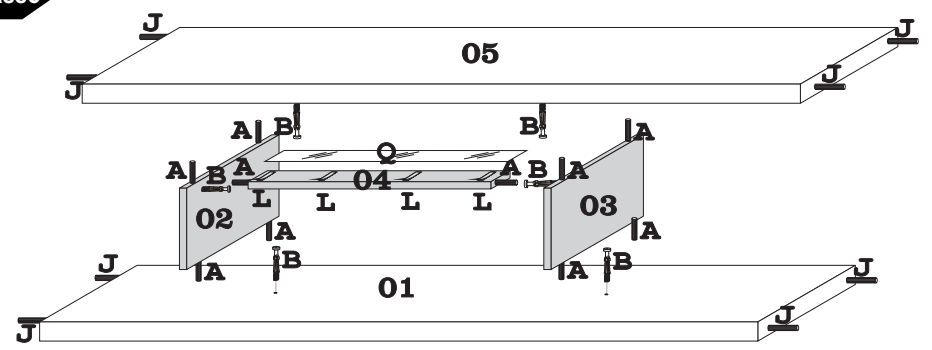

2º Passo

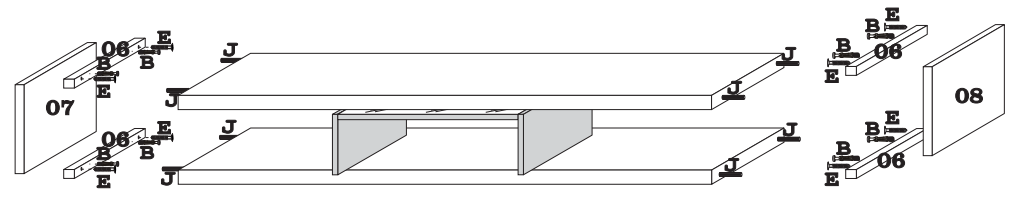

3º Passo

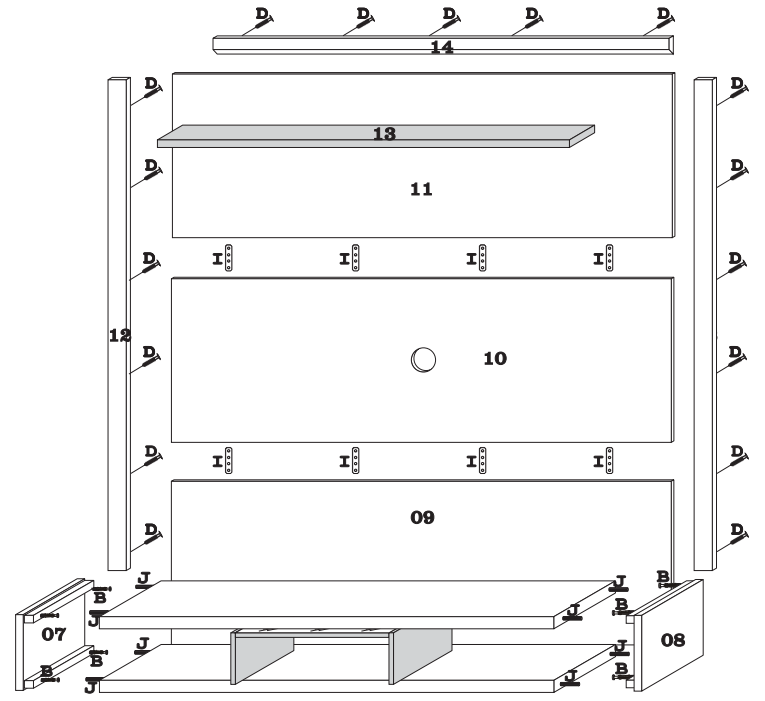

**4º Passo** *Vista Traseira:*  
Vista posterior: /Rear View:

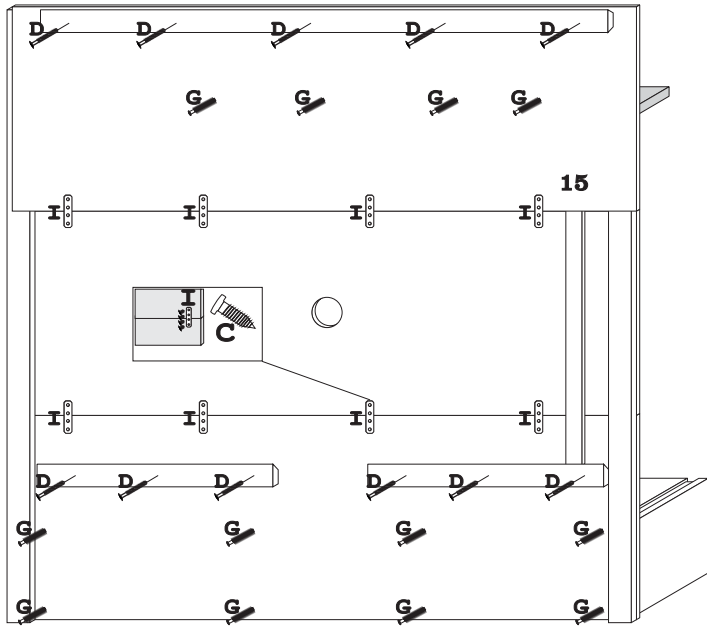

**5º Passo**

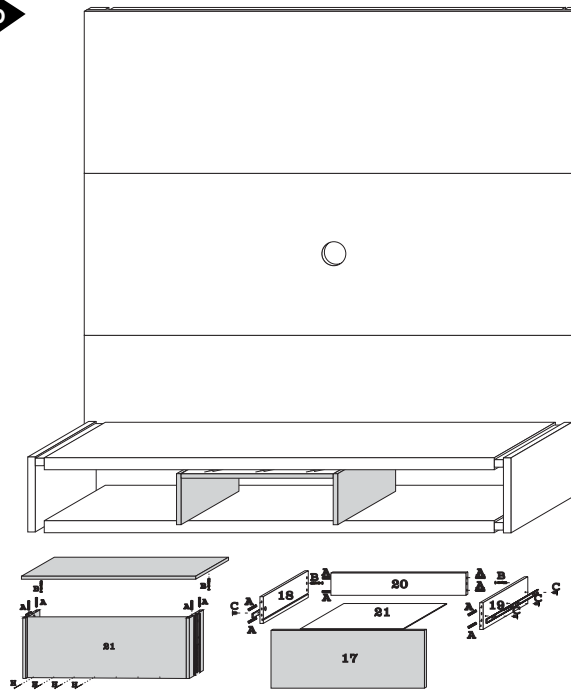

**6º Passo**

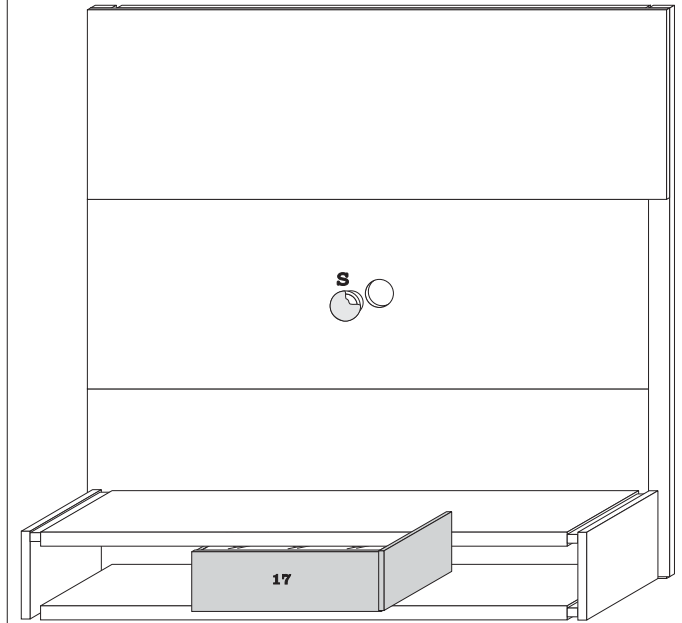

**7º Passo**

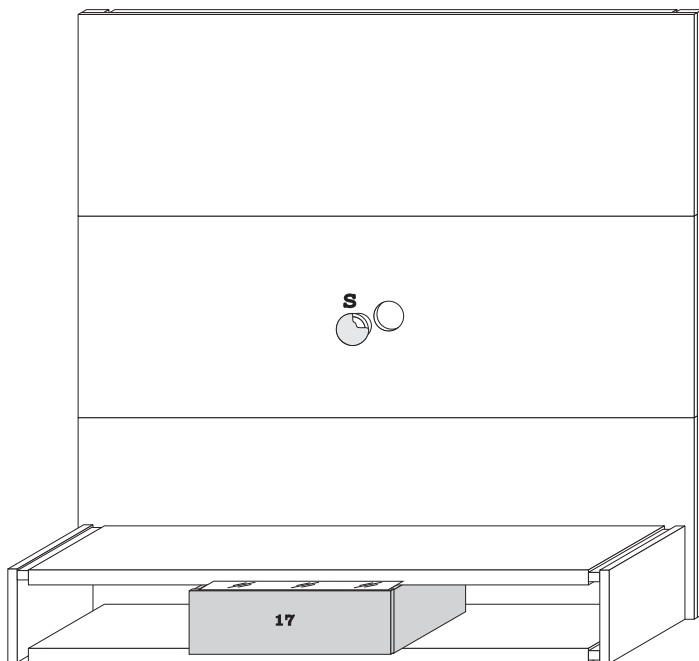

**8º Passo**

**Fixação do painel na parede:**  
La fijación del panel en la pared/  
Fixing the panel on the wall;

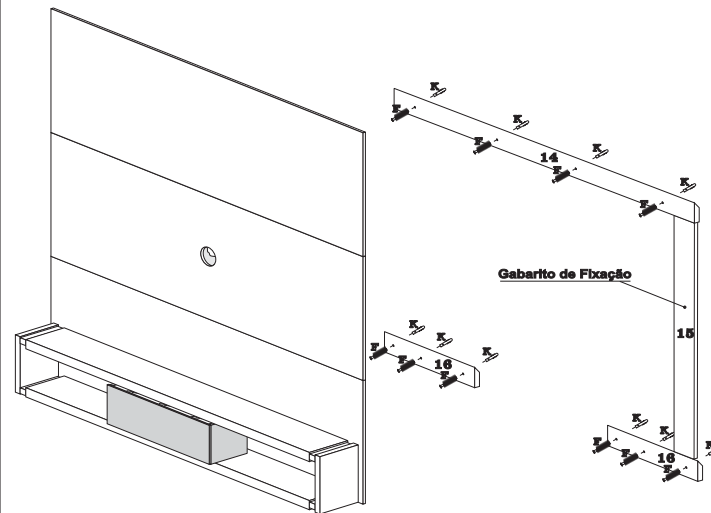

**Peso máximo por espaço;**

*Peso máximo para el espacio;*  
*Maximum weight for space;*

