

---

# Upright Freezer

---

**Thank you for your trust and for buying this appliance. We hope it will successfully serve the purpose for many years.**

The **upright freezer** for domestic use is intended for freezing fresh food and for long-term storing of frozen food (up to one year, depending on the kind of food).

<b>Before Putting Into Use</b> .....	<b>48</b>	Sound alarm button, red light (3)	
Instructions for Use		Temperature Selection (4)	
We Care for the Environment		External Temperature Meter (5)	
Tips for Energy Saving		<b>Use</b> .....	<b>54</b>
<b>Important</b> .....	<b>49</b>	Freezing Fresh Foods	
Disposing of the Worn Out Appliance		Storing Frozen Foods	
<b>Placing and Installation</b> .....	<b>50</b>	Defrosting of Frozen Food	
Choosing the Right Place		<b>Maintenance and Cleaning</b> .....	<b>56</b>
Placing the Appliance		Freezer Defrosting	
Connection to Power Supply		Cleaning the Appliance	
<b>Description of the Appliance</b> .....	<b>51</b>	Switch Off the Appliance When Not in Use	
<b>Operation Control</b> .....	<b>52</b>	<b>Changing the Direction of Opening</b>	
Control panel		<b>the Door</b> .....	<b>57</b>
ON/OFF Switch (1)		<b>Trouble Shooting Guide</b> .....	<b>58</b>
Operation Mode Selection Switch (2)			

---

# **i** Before Putting Into Use

---

- Before connecting the appliance to the mains supply, leave it stand for about 2 hours which will reduce the possibility of malfunctions in the cooling system that might have occurred due to transport handling.
- Clean the appliance thoroughly, especially the interior (see Cleaning and Maintenance).
- Always consider instructions stated in sections Positioning and Energy Saving Tips, otherwise the energy consumption is substantially higher.
- Sound alarm reminds you to close the door immediately, in order to save energy.

## **Instructions for Use**

These instructions for use were prepared for the user. They describe the appliance and its correct and safe use. They were prepared for various types/models of appliances therefore you might find in it description of some functions and accessories that do not apply to your appliance.

## **We Care for the Environment**

- Our products use environmentally friendly packaging, which can be either recycled or disposed of in an environmentally friendly manner. To this end, individual packaging materials are clearly marked.
- These instructions are printed either on recycled paper or chlorine free bleached paper.
- When your appliance finally wears out, please try not to burden the environment with it; call your nearest authorised service agent. (See Disposing of the Worn Out Appliance)

## **Tips for Energy Saving**

- This is especially important if you have an upright model.
- Every now and then check if the appliance is sufficiently ventilated (adequate air circulation behind the appliance).
- Turn the thermostat knob from higher to lower setting as soon as possible (depends on how loaded the appliance is, ambient temperature...)
- Never use continuous operation unless unnecessarily required; switch the operation mode selection switch to the setting for automatic operation as soon as possible.
- Before freezing packages of fresh foods, make sure they are cooled to ambient temperature.
- Ice and frost layer increase energy consumption, so do clean the appliance as soon as the layer is 3-5 mm thick.
- If the gasket is damaged or if it turns out that the sealing is poor, the energy consumption is substantially higher. To restore efficiency, replace the gasket.
- The condenser on the rear wall should be always clean, free of dust or any impurities.



## Important

- If you've bought this appliance to replace an old one equipped with a lock that cannot be opened from inside (lock, bolt), make sure that the lock is broken. This will make it impossible for the children to lock themselves in the appliance and suffocate.
- Mind to connect the appliance correctly to the mains supply (see Connection to the Mains Supply).
- Do not touch the cooled surfaces while the appliance operates, especially not with wet hands, because the skin might stick to the cold surfaces.
- Do not freeze bottled drinks, especially not fizzy ones such as mineral water, sparkling wine, beer, cola etc., because liquid expands during freezing and the glass bottle is very likely to blow up.
- Never try to eat frozen food (bread, fruit, vegetables), because you may get frostbites.
- Carefully check the foods for color and smell and if you are in doubt about their quality, throw them away because they may be spoiled and therefore dangerous to eat.
- Disconnect the appliance from the mains before repairing (only a qualified technician should repair it) and before cleaning.
- Do not defrost the appliance with other electric devices (hair dryer etc.) and never scrape the ice or frost layer with sharp tools. Use only enclosed tools or tools recommended by the manufacturer.
- For the sake of environment protection - be careful not to damage the rear wall of the appliance (the condenser unit or the tubes - for example when moving the appliance) or any part of the refrigerating system inside the appliance.
- The refrigerating system of the appliance is filled with refrigerant and oil, so when the appliance is damaged, handle it with care and dispose it of in compliance with environmental protecting precautions. (See We Care for the Environment).
- Heating element incorporated in the appliance, all around the rim, is controlled by the operation of the compressor and it prevents the door gasket to freeze on to the freezer housing.
- If the supply cord is damaged, it must be replaced by the manufacturer or his service agent or a qualified person in order to avoid hazard.
- The rating plate is in the interior or on the rear wall of the appliance.

### Storing Time During Power Supply Interruption

Avoid opening the freezer in case of failure or power supply interruption! In case the interruption is extended over longer period of time (17 hours), take food out of the freezer and use it, or make sure it remains well cooled (perhaps you have an extra appliance).

### Disposing of the Worn Out Appliance

- When your appliance finally wears out, dispose it of. If the appliance has a lock, break it, in order to prevent eventual accidents (danger of children get locked inside the appliance).
- The refrigerating system of the appliance is filled with refrigerant and insulating substances which should be separately treated and processed. Call your nearest authorised service agent or specialised servicing centre. If you don't find one, contact your local authorities or your distributor. Be careful not to damage the tubes on the rear wall of the appliance (danger of pollution).

# Placing and Installation

## Choosing the Right Place

Place the appliance in dry and well ventilated room. Allowed ambient temperature depends on the model (class) of the appliance and is stated on the rating plate of the appliance. Never place the appliance near heat emitting devices (e.g. cooker, radiator, water heater and similar devices) and do not expose it to direct sunlight.

The appliance should be positioned at least 3 cm away from the electric or gas cooker and at least 30 cm away from the oil or coal stove. If this is not possible, use an appropriate insulation. Behind the appliance there should be free space at least 200 cm<sup>2</sup> wide and above the appliance the high kitchen units should be at least 5 cm away from the appliance in order to assure adequate ventilation of the condenser unit.

Class	Ambient temperature
SN (sub-normal)	from + 10°C to + 32°C
N (normal)	from + 16°C to + 32°C
ST (sub-tropical)	from + 18°C to + 38°C
T (tropical)	from + 18°C to + 43°C

## Placing the Appliance

- Place the appliance firmly on a solid base. Some appliances have adjustable feet on the front side; use them to level the appliance.

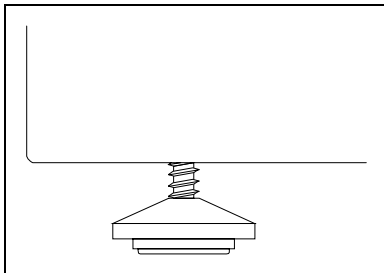

- Two spacers attached to the appliance must be fitted onto the upper edge of the condenser, thus preventing the appliance from being installed too close to the wall. Spacers are manufactured for all-purpose function depending on the distance of the condenser from the wall. Therefore turn spacers correspondingly and fix them to the appliance.

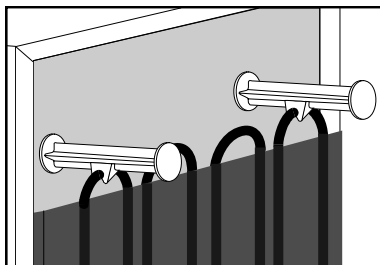

## Connection to Power Supply

Connect the appliance with the cable and plug to the power supply socket outlet with a ground terminal (safety socket).

Required nominal voltage and frequency are indicated on the rating plate.

The connection to the mains supply and earthing have to be made according to current standards and regulations. The appliance resists temporary voltage tolerance up to -15 to +10 %.

# Description of the Appliance

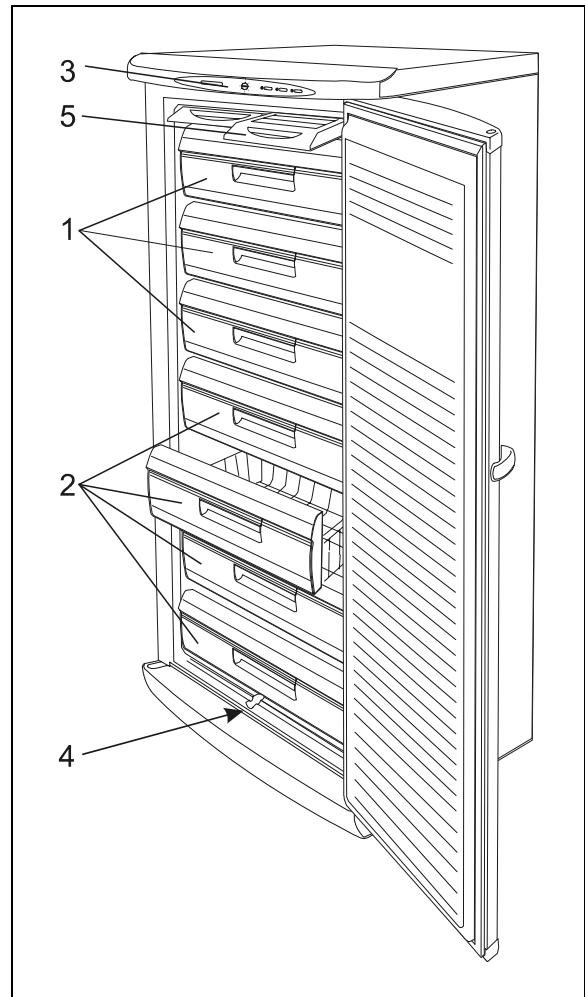
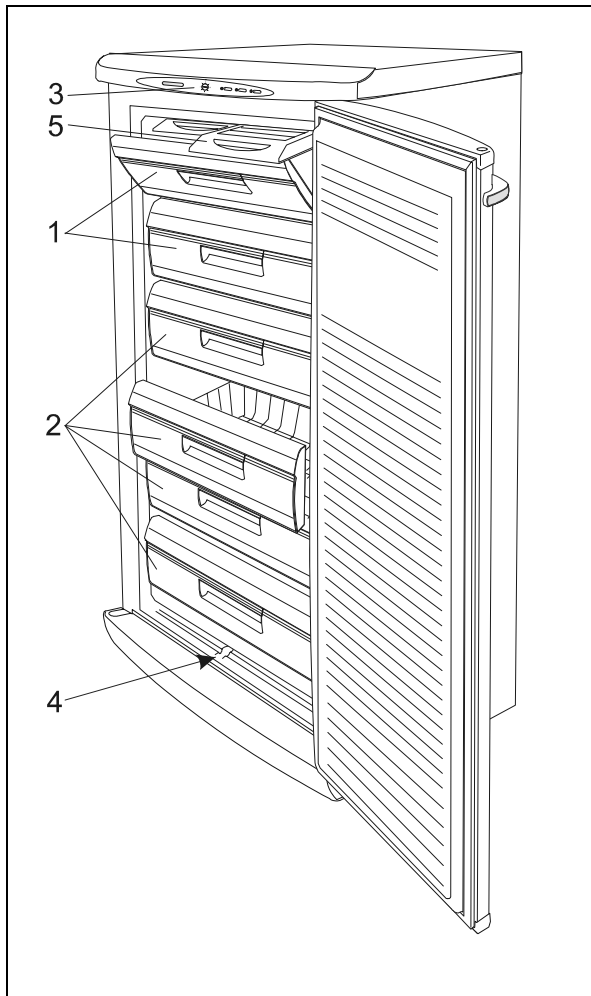

## Freezing Compartment (1)

is used for freezing fresh foods.

## Storing Basket (2)

is used for storing packages of frozen foods.

## Control Panel (3)

See Operation Controls

## Defrost Water Outlet (4)

(See Cleaning and Maintenance).

## Cold accumulators (5)

(some models only)

In the upper part of the freezing compartment there are two cold accumulators. Before switching on the freezer for the first time, remove the accumulators and insert them again after the red light is off.

- Both accumulators maintain uniform temperature of frozen foods therefore assuring higher quality of foods and reducing energy consumption.
- If you remove the accumulators, the compartment can be used for freezing fruits (for example berries) or for ice making.
- These accumulators can as well be used for maintaining lower temperatures of foods and bottles, for example when you make a trip or a picnic.

## NOTE:

- The appliance can be equipped with various accessories, depending on the model of the appliance.
- Door handles have various shapes, depending on the model.

# Operation Control

The freezer is controlled with two switches and thermostat knob incorporated in the interior of the freezer.

## Control panel

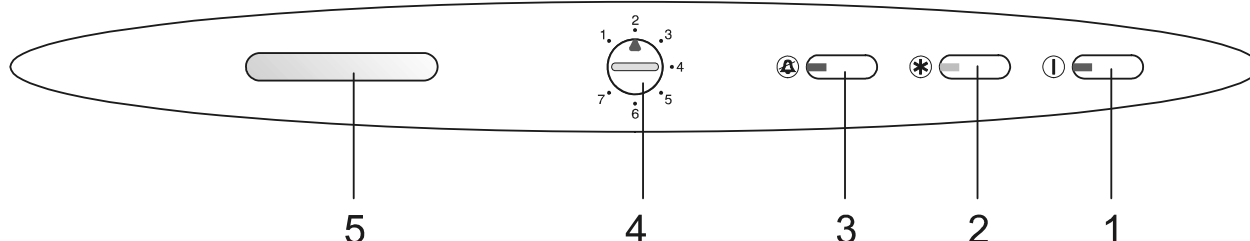

- 1 ON/OFF button
- 2 Mode selection button
- 3 Sound alarm button, red light

- 4 Temperature selector
- 5 External thermometer

## ON/OFF Switch (1)

The appliance is switched on - the green light is on.  
The appliance is switched off - the green light is off.

## Sound alarm button, red light (3)

Sound alarm is triggered and red light is on if the freezer compartment is not under correct temperature (see section Troubleshooting guide). Alarm is triggered also when the door remains open for some time. It may be stopped by closing the door.

## Operation Mode Selection Switch (2)

This switch is used to select one of the two operation modes: continuous and automatic.

### Continuous operation - the yellow light is on.

The cooling system operates continuously. This mode is selected when you want to freeze large amounts of fresh foods and in case you want to deep freeze already frozen foods.

### Automatic operation - the yellow light is off.

The interior temperature is controlled by the thermostat which turns the cooling system on and off.

The frequency of switching the cooling system on and off depends on:

- the thermostat knob position (thermostat setting),
- how often you open the door; and
- ambient temperature.

## Temperature Selection (4)

When the freezer operates automatically, the interior temperature is controlled by the thermostat.

The most suitable thermostat position is in the middle between **max (7)** and **min (1)**.

We recommend setting the thermostat on positions towards **max (7)** only in case you want to accelerate cooling, as for example before loading smaller amounts of fresh foods or when the operation mode shall correspond to the ambient temperature.

Thermostat settings towards **min (1)** help you save energy provided that the freezer is loaded with smaller amount of frozen foods.

Changes of the ambient temperature affects temperature in the interior of the appliance. Choose correct setting of the thermostat knob.

## External Temperature Meter (5)

The meter shows approximate temperature in the interior of the freezer. The most convenient temperature for long term storing of frozen foods is  $-18^{\circ}\text{C}$  or colder. Optimum storage conditions depend on the thermostat setting, ambient temperature, how loaded the appliance is and how often you open the door.

Don't forget, temperature changes are noted on the meter some 48 hours after the thermostat position was changed.

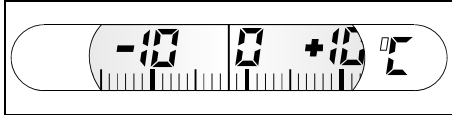

---

# Use

---

## Switching On the Empty Freezer

Switch the freezer on. Sound alarm is on because of inappropriate temperature. It may be switched off by pressing the alarm button .

Put the mode selection switch to the continuous operation position. All three signal lamps are on. Place fresh food into the freezer several hours after the red signal lamp goes off.

## Freezing Fresh Foods

Proper use of the appliance, adequately packed food, correct temperature and taking into account hygienic precautions will substantially influence the quality of freezing the food or storing of the frozen foodstuffs.

- Carefully select food to be frozen: it should be of adequate quality and suitable for freezing.
- Choose correct packaging for each kind of food and pack it correctly.
  - The packaging should be air tight and well sealed without leaking since this could cause substantial vitamin loss and dehydration.
  - Foils and bags should be soft enough to tightly wrap around the food.
- Mark packages with following data: kind and amount of foods and the date of loading.
- It is most important that the food is frozen as quickly as possible. We therefore recommend the size of the package not to be too large and to be cooled before loading into the freezer.
- The amount of the fresh foods that can be loaded in the freezer within 24 hours is stated on the rating plate. If the loaded amount is too large, the quality of freezing is reduced which affects the quality of frozen foods.

## Freezing Procedure

Freezing compartment is used for freezing foodstuffs (see chapter Description of the Appliance).

- If you want to freeze larger amount of fresh food, set the operation mode selection switch to the position for continuous operation (yellow light is on). After 24 hours you can load the freezing compartment with packages of fresh foods.
- 24 hours after the food was loaded, the frozen packages can be stored into baskets and the freezer can be loaded with new packages of fresh foods. Don't let the fresh packages touch the frozen ones.
- Some 24 hours after the last load, set the switch to the position for automatic operation (yellow light is off).

- There is no need to set the switch to the position for continuous operation if you intend to freeze smaller amount of fresh foods (1-2 kg).

## Storing Frozen Foods

Packages of frozen foods are stored in baskets. If you remove the baskets, you can store frozen packages directly on the cooling shelves.

## Storing Commercially Frozen Foods

The storage time and recommended temperature for storing commercially frozen foods is indicated on the packaging. For storing and use consider manufacturer's instruction.

When shopping, be careful and choose only packages of foods which are adequately packed and provided with complete data and stored in freezers where the temperature is not higher than  $-18^{\circ}\text{C}$ .

Do not buy packages of food wrapped with frost. This indicates that the package was thawed before at least once. Take care that packages don't start to thaw. Temperature rise shortens the storage time of commercially frozen foods.



## Approximate Storage Time of Frozen Foods

Food	Storage time (in months)											
	1	2	3	4	5	6	7	8	9	10	11	12
Vegetable								+	+	+		
Fruit										+	+	+
Braed, Pastries			+									
Milk			+									
Redy-made meals			+									
Meat: Beef										+	+	+
Veal								+	+	+		
Pork				+	+	+						
Poultry								+	+	+		
Game						+	+	+				
Minced meat				+								
Smoked sausages	+											
Fish: lean			+									
fat	+											
Offal		+										

## Defrosting of Frozen Food

Partially thawed or defrosted foods should be used as soon as possible. Cold air preserves the food but it does not destroy microorganisms which rapidly activate themselves after defrosting and make foods perishable.

Partial defrosting reduces the nutritional value of foods, especially of fruits, vegetables and ready-made meals.

# Maintenance and Cleaning

## Freezer Defrosting

Frost and ice layer, depositing on the inner walls of the freezer should be defrosted when 3-5 mm thick.

- 24 hours before defrosting set the switch to continuous operation (the yellow light is on) so that the food packages are well cooled. After that empty the freezer and take care that the packages don't start to thaw.
- Disconnect the appliance from the mains supply.
- Insert the enclosed pipe into the groove in the bottom of the appliance and place a vessel underneath to collect the defrost water. Defrosting is accelerated if the door is left open.
- Avoid using defrosting sprays, as they may cause damage to the plastic parts and may be hazardous to health.

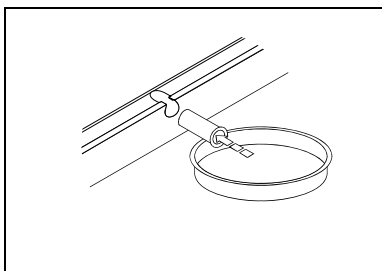

- From time to time wipe the **condenser** on the rear wall with a soft non-metal brush or vacuum cleaner.

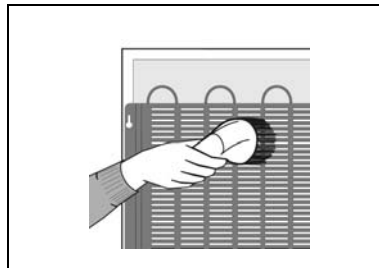

After you have cleaned the appliance, reconnect it to the mains supply and put the food packages back to their place.

## Switch Off the Appliance When Not in Use

If you do not intend to use the appliance for a longer period of time, disconnect the power supply, empty the appliance, defrost it and clean it. Leave the door slightly open.

## Cleaning the Appliance

**Before cleaning the appliance disconnect the cable from the mains supply.** Do not use abrasive cleaning agents. Be careful to remove any cleanser agent remaining after cleaning.

- Clean the **exterior** of the appliances with water and liquid detergent. Varnished surfaces are cleaned with soft cloth and an alcohol based cleaning agent (for example glass cleaners). You may also use alcohol (ethanol or isopropyl alcohol). The application of abrasive and specially aggressive cleaners, such as the stainless steel cleaners, is not appropriate for the cleaning of plastic and coated parts.
- Wash the **interior** with lukewarm water and some vinegar.

# Changing the Direction of Opening the Door

If you find the direction of opening the door on your appliance inconvenient, you can change it. Holes on the opposite side have already been prepared in the factory.

- Unscrew the kick-plate and remove it by pushing downwards.
  - Unscrew the lower hinge and take off the door together with the upper hinge washer.
  - Unscrew the upper hinge fastener and fix it on the opposite side of the appliance.
  - Take off, change and replace the door hinge fixture and the fixture plugs.
  - Put the door with the upper hinge washer on the upper hinge fastener.
- Fix the lower hinge with washer on the new position.
  - Replace the cover plate of the lower hinge to the opposite side of the kick-plate and place it to the appliance.
  - In case your appliance is equipped with a handle mounted on the side of the appliance, take it off and replace it on the other side. Some screws are covered with caps. Take them off before undoing the screws.
  - Check the gasket, it shouldn't be creased and it should seal well.

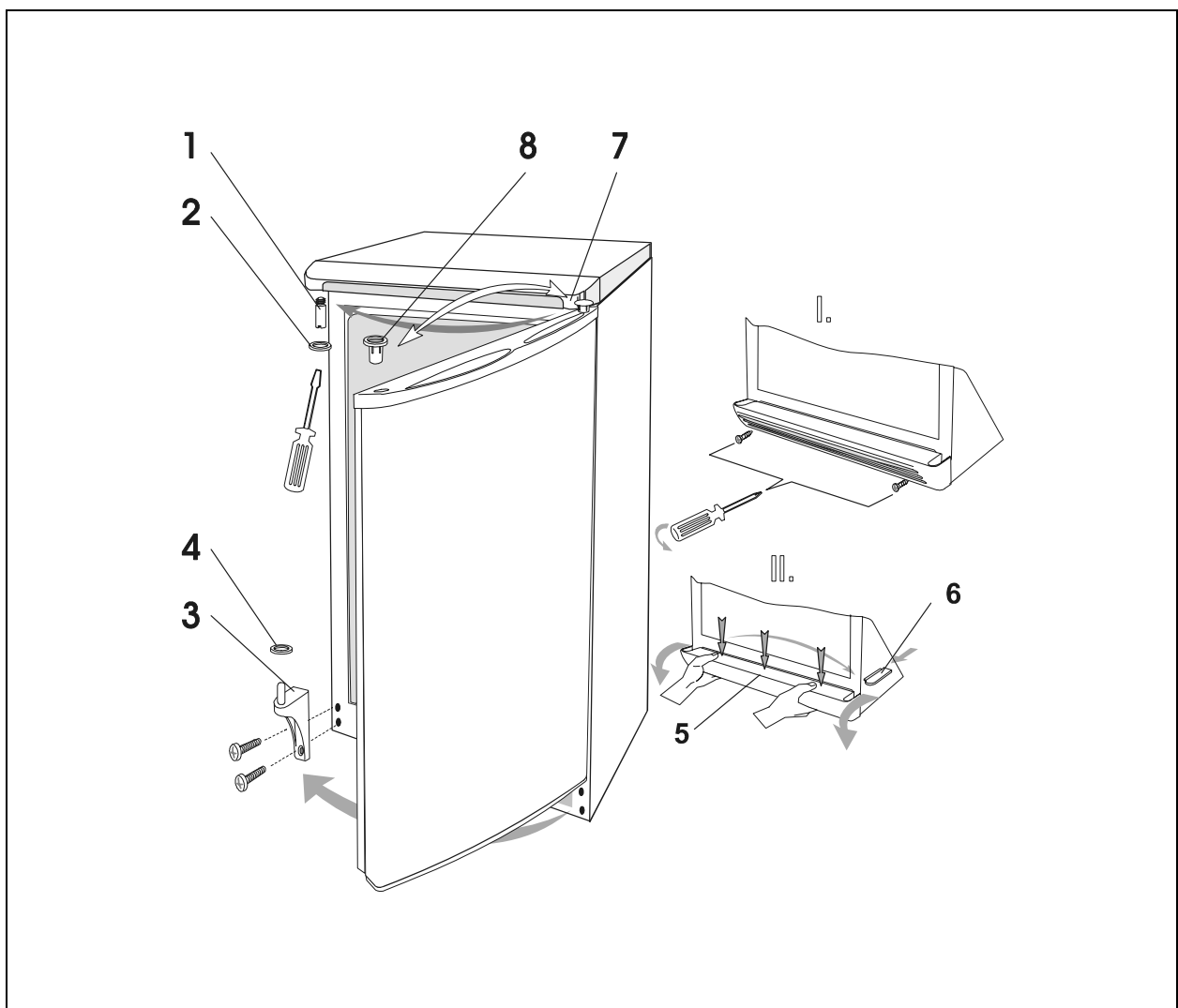

- 1 Upper hinge fastener
- 2 Upper hinge washer
- 3 Lower hinge
- 4 Lower hinge washer

- 5 Kick plate or control panel
- 6 Cover plate of the lower hinge
- 7 Fixture plug of the door hinge
- 8 Door hinge fixture

---

# ❓ Trouble Shooting Guide

---

During the service, you can come across some troubles that in most cases result from improper handling of the appliance and can easily be eliminated.

## The Appliance Fails to Operate After Connecting to the Mains Supply

- Check the supply in the outlet socket and make sure the appliance is switched on (the green light is on).

## Sound alarm button, The Red Light is On

- The door was frequently opened or it was left open for too long.
- The door is not properly closed (the door may sag, the gasket may be polluted or damaged).
- Power supply has been interrupted for a longer period of time.
- Perhaps you have overloaded the appliance with fresh foods.

To stop the sound alarm press the alarm button . Red light goes off when the malfunctions are removed and the temperature within the appliance reaches the appropriately low level (depending upon the thermostat setting).

## Continuous Operation of the Cooling System

- Set the operation mode selection switch from continuous to automatic operation.
- The reason may be inadequate ventilation of the compressor and condenser (assure adequate air circulation behind the appliance and wipe the dust from the condenser).

## The Door is Hard to Open

If you want to open the door that has just or recently been closed, you may find it hard to open. The reason why this happens is, that when you open the door, warm air gets into the appliance and when it is cooling, the underpressure seals the door. After few minutes (5-10), the door can easily be opened.

## Noise

Cooling in refrigerating-freezing appliances is enabled by the cooling system with compressor, which produces noise. How noisy the appliance is depends on where it is placed, how it is used and how old the appliance is.

- **During the operation** of the compressor the noise of liquid is heard and when the compressor is not operating, the refrigerant flow is heard. This is a normal condition and it has no influence whatsoever on the lifetime of the appliance.
- **After starting the appliance**, the operation of the compressor and the refrigerant flow may be louder, which does not mean that something is wrong with the appliance and it has no influence on the lifetime of the appliance. Gradually the noise is reduced.
- Sometimes **unusual and stronger noise** is heard, which is rather unusual for the appliance. This noise is often a consequence of inadequate placing. (The appliance shall be placed and levelled firmly on solid base and it should not touch the wall or kitchen units standing next to it.)

## Bulb Replacement

(models with interior illumination only)

Before replacing the light bulb, disconnect the appliance from the power supply.

Remove the plastic cover with the screwdriver and replace the bulb with a new one (E14, max. 15 W).

Don't forget: the old bulb does not belong to organic waste.

**Light bulb is consuming good therefore our in-guarantee service does not relate to it.**

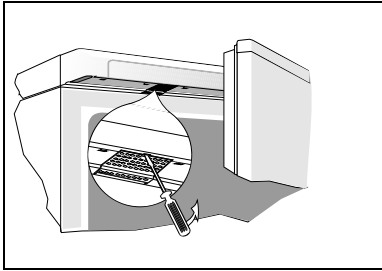

WE RESERVE THE RIGHT TO ALTER THE SPECIFICATIONS WITH NO INFLUENCE  
ON THE OPERATION OF THE APPLIANCE.