

ZANUSSI

FRIDGE-FREEZER
ZI 8454 X

INSTRUCTION BOOKLET



IMPORTANT SAFETY INFORMATION

It is most important that this instruction book should be retained with the appliance for future reference. Should the appliance be sold or transferred to another owner, or should you move house and leave the appliance, always ensure that the book is left with the appliance in order that the new owner can get to know the functioning of the appliance and the relevant safety information.

This information has been provided in the interest of safety. You **MUST** read it carefully before installing or using the appliance.

Installation

- This appliance is heavy. Care should be taken when moving it.
- It is dangerous to alter the specifications or attempt to modify this product in any way.
- Care must be taken to ensure that the appliance does not stand on the electrical supply cable.
Important: if the supply cable is damaged, it must be replaced by a special cable available from your local Service Force Centre.
- Any electrical work required to install this appliance should be carried out by a qualified electrician or competent person.
- Parts which heat up should not be exposed. Whenever possible, the back of the appliance should be close to a wall but leaving the required distance for ventilation as stated in the installation instructions.
- The appliance should be left for 2 hours after installation before it is turned on, in order to allow the refrigerant to settle.

Child Safety

- Do not allow children to tamper with the controls or play with the product.
- Keep all packaging well away from children.

General Safety

- **This appliance contains hydrocarbons in its cooling unit; maintenance and recharging must therefore only be carried out by authorized technicians.**
- **Take utmost care when handling your appliance so as not to cause any damages to the cooling unit with consequent possible fluid leakages.**
- **The appliance must not be located close to cookers, radiators or boilers.**
- **Avoid prolonged exposure of the appliance to direct sunlight.**
- **Do not use other electrical appliances (such as ice cream makers) inside of refrigerating appliances.**

During Use

- This appliance is designed for domestic use only, specifically for the storage of edible foodstuffs.

- Frozen food must NOT be re-frozen once it has thawed out.
- Do not place carbonated or fizzy drinks in the freezer.
- Do not remove items from the freezer if your hands are damp/wet, as this could cause skin abrasions or frost/freezer burns.
- Ice lollies can cause 'frost/freezer burns' if consumed straight from the freezer.
- Manufacturers' storage recommendations should be strictly adhered to. Refer to relevant instructions.
- The cooling plate or refrigerated freezer shelves in this appliance contain channels through which the refrigerant passes. If these are punctured this will cause substantial damage to the appliance and result in food loss. **DO NOT USE SHARP INSTRUMENTS** to scrape off frost or ice. Under **NO** circumstances should solid ice be forced off the lining or shelves. Solid ice should be allowed to thaw, when defrosting the appliance. See Defrost Instructions.

Maintenance and Cleaning

- Switch off and unplug the appliance before carrying out any cleaning or maintenance work.

Servicing

- This product should be serviced by an authorised engineer and only genuine spare parts should be used.
- Under no circumstances should you attempt to repair the machine yourself. Repairs carried out by inexperienced persons may cause injury or serious malfunctioning. Refer to your local Service Force Centre and always insist on genuine spare parts.

At the end of the Appliance Life

- When disposing of your appliance, use an authorised disposal site.
- Remove the plug and ensure that any locks or catches are removed, to prevent young children being trapped inside.

CONTENTS

Instructions for the User

Important Safety Information	2
Description of the Appliance	4
Operation	5
Before using	5
Starting up	5
Warning light	5
Electronic thermometer	5
Refrigerator compartment	6
Drinks dispenser	6
Superchill compartment	7
Freezer compartment	7
Useful hints for freezing	8
Storing frozen foods	8
Thawing food	8
Ice cube maker	8
Maintenance and Cleaning	9
Periodic cleaning	9
Defrosting	9
Periods of non operation	10
Replacing the bulbs	10
Something Not Working	11
Service and Spare Parts	12
Customer Care	12
Guarantee Conditions	13

Instructions for the Installer

Technical Specification	14
Installation	15
Positioning	15
Electrical Connection	16
Positioning	17
Height adjustment	17
Fitting the side panels	17
Building the appliance in	18
Fitting the plinth	18

DESCRIPTION OF THE APPLIANCE

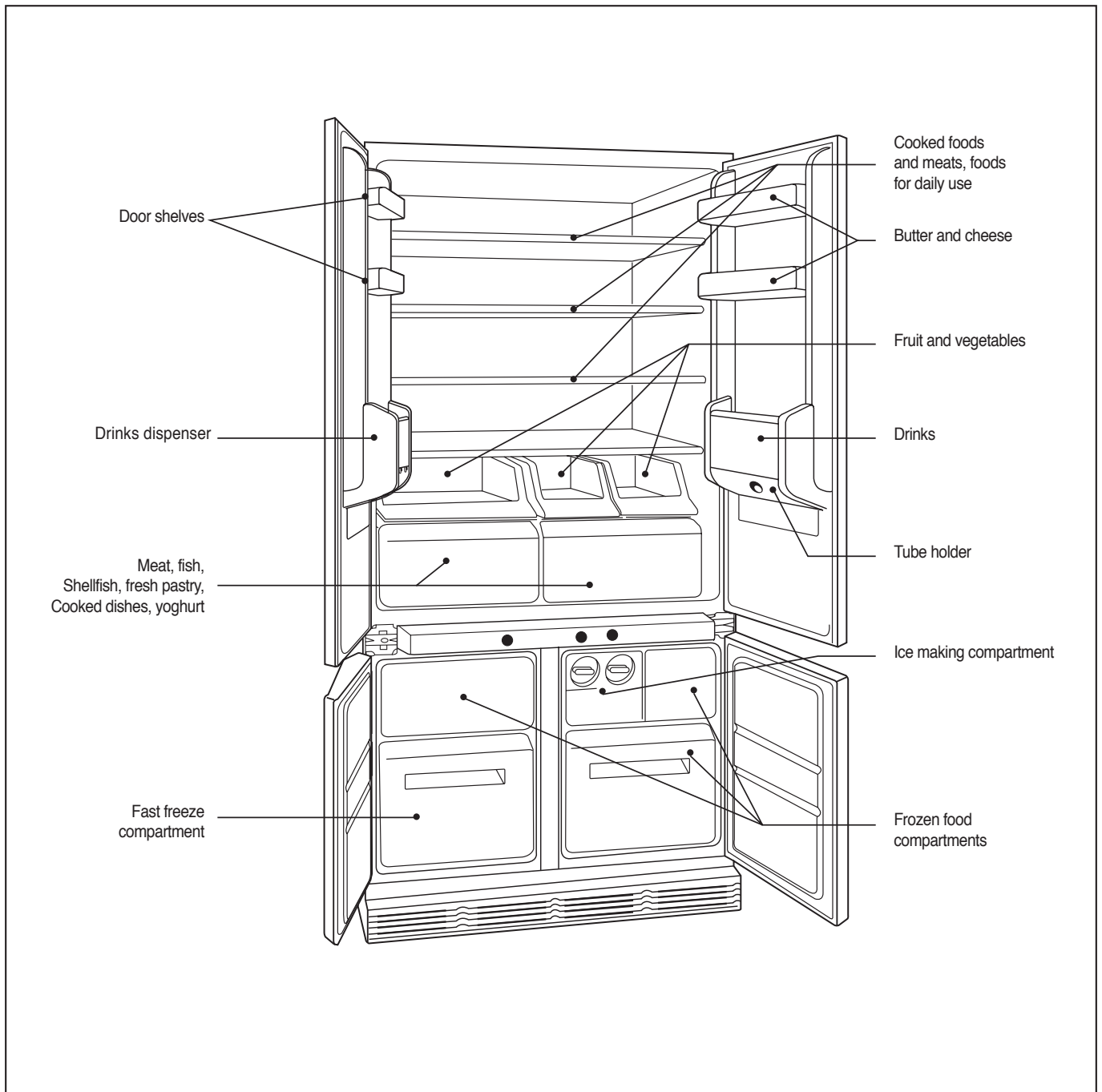

OPERATION

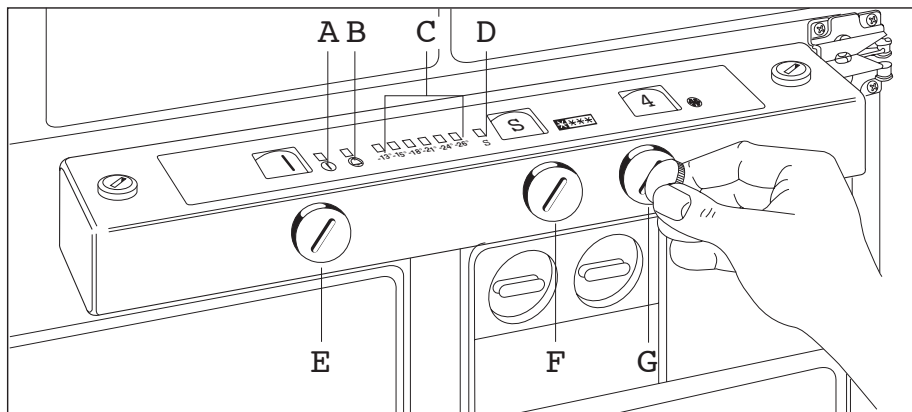

- A = «Mains On» light
- B = Freezer alarm light
- C = Freezer electronic thermometer
- D = Fast Freeze indicator (S)
- E = Main On/Off switch
- F = Freezer and Fast Freeze (S) temperature control knob
- G = Refrigerator temperature control knob

Before using

Remove all securing tapes. Wash inside the appliance with lukewarm water and bicarbonate of soda (5 ml to 0.5 litre of water).

Do not use soap or detergent as the smell may linger. Dry thoroughly.

Starting up

- Turn switch E until the pointer is opposite the «I» symbol (pilot lights A and B will come on).
- Turn refrigerator temperature knob G and freezer temperature knob F to the required position; in general a mid position is best (the lower the number, the warmer the temperature).
- Pilot light D comes on when knob F is turned to position «S».

The refrigerator and freezer are switched off by turning switch E to position «O».

Electronic thermometer

The electronic thermostat C consists of 6 pilot lights. Each light corresponds to a temperature inside the freezer. Frequent or prolonged opening of the doors may slightly modify the temperature indicated. Temperature variations can also occur if excessive quantities of food are loaded into the freezer (see freezing capacity).

Warning light

The alarm light B indicates when the temperature inside the freezer compartment has risen to a point at which safe storage of frozen foods can no longer be guaranteed. When the appliance is first started up, or after having loaded a quantity of food to be frozen, this warning light will stay on until a safe storage temperature has been reached.

Refrigerator compartment

- Do not place hot food or drinks in the refrigerator; wait until they have cooled to room temperature.
- Always cover foods, especially those which have a strong flavour.
- Place foods so that air can circulate freely round them.

The thermostat position may be adjusted to compensate for temperature variations due to:

- The frequency with which the doors are opened.
- Difference in ambient temperature.
- Quantity of food being stored.

To make the best use of available space, the front half-shelves may be stacked on top of the rear halfshelves.

During prolonged periods of abnormally hot weather, if the thermostat is set on too high a number, the cooling system may operate continuously and the fridge cooling plate may not defrost. Turning the knob to a lower number will cause the automatic defrosting to resume.

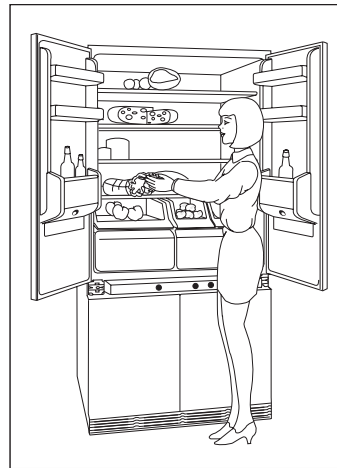

Drinks dispenser

The ideal way to travel cool drinks «on tap».

Take a bottle of your favourite drink and fit the special dispenser top.

Place the bottle upside down in the holder on the inside of the door and secure it with clamp B.

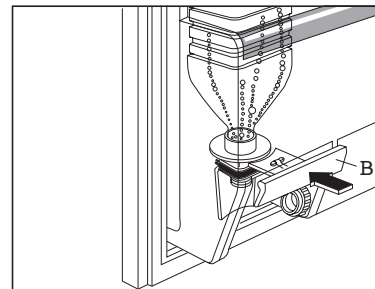
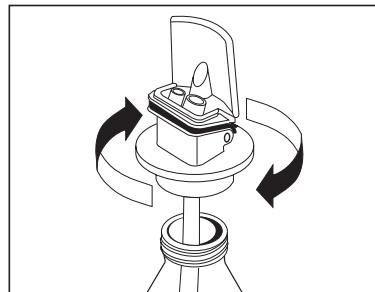

Press the glass gently against the tab to dispense drinks.

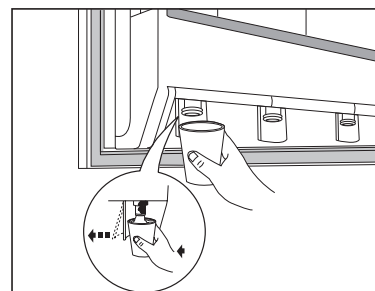

If the dispenser will not fit the bottle, use special adaptor A, supplied with the appliance.

To ensure proper operation, it is general best to avoid dispensing freshly squeezed fruit juice

Wash the dispenser from time to time.

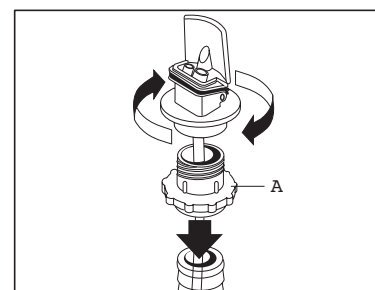

Superchill compartment

- The temperature in this compartment (from 0°C to +3°C) is kept constant by a special sensor. No adjustment is needed.
- Products stored in this compartment will keep fresh and in peak condition. It is advisable to wrap foods in aluminium foil or plastic film.
- Drinks can be cooled quickly in this compartment without any danger of freezing
- Make sure that the drawers are fully closed before shutting the door.

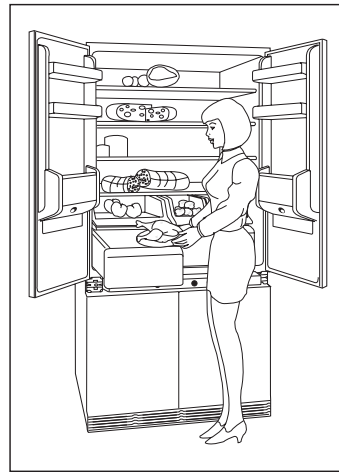

Freezer compartment

- If food is to be frozen immediately after having installed the appliance or after a prolonged period out of use, turn temperature control knob F to position «S» and allow the appliance to run for at least 4 hours before placing the food in it.

If the freezer is already operating, with food inside it, turn knob F to position «S» 24 hours before loading food to be frozen.

Freezing will take 24 hours, after which knob F should be turned to the mid position.

- The alarm light indicates when the temperature inside the freezer compartment has risen to a point at which safe storage of frozen foods can no longer be guaranteed. When the appliance is first started up, or after having loaded a quantity of food to be frozen, this warning light will stay on until a safe storage temperature has been reached.
- Products to be frozen should be placed in the fast freeze compartment and, once frozen, moved to the storage baskets.
- The maximum freezing capacity is 12 kg in 24 hours. Do not freeze more than one quantity at a time.
- The electronic thermostat consists of 6 pilot lights. Each light corresponds to a temperature inside the freezer. Frequent or prolonged opening of the doors may slightly modify the temperature indicated. Temperature variations can also occur if excessive quantities of food are loaded into the freezer (see freezing capacity).

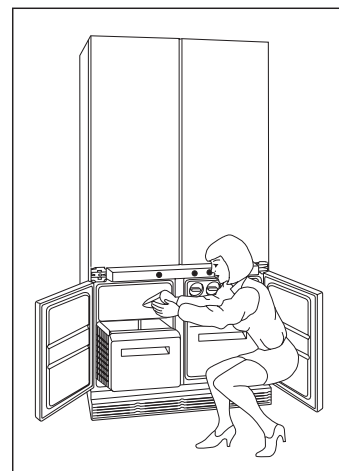

Useful hints for freezing

- Products to be frozen should be fresh and clean.
- Pack foods in suitable family portions which can be used up all at once.
- Small packs allow fast and uniform freezing.
- Lean foods keep better and longer than fatty foods. Salt reduces the storage life of food.
- Wrap foods closely in aluminium foil or plastic bags or flim, and make sure they are properly sealed.
- Attach a label to each pack, indicating the contents and the date on which it was prepared.
- Never place hot foods, bottles or containers with fizzy drinks in the freezer (they could explode).
- Do not fill containers with lids right to the brim.
- Do not add more food or open the doors during the freezing process.
- Never place food to be frozen in contact with already frozen food, as this would increase the temperature of the latter.

Storing frozen foods

After having started up the freezer, select the fast freeze function (knob F to position «S») at least 3 hours before loading frozen food. Then return the knob to the normal storage temperature (knob F to the mid position).

There are no particular problema in storing frozen foods. Packs may be placed next to or on top of each other.

When buying frozen foods, get them home and into your freezer as quickly as possible. Packs which are damaged or show traces of moisture indicate that the product has not been stored at the correct temperature and that the food may have lost its original quality.

Partially defrosted foods must never be re-frozen and must be consumed as quickly as possible. Never consume products after the date shown on the pack.

In the event of a short power cut, foods will not be affected, but you should avoid opening the appliance doors.

Important

If there is a power failure when food is in the freezer, do not open the door of the freezer compartment. The frozen food will not be affected if the power cut is of short duration (up to 6-8 hours) and the freezer compartment is full, otherwise, it is recommended that the food should be used within a short time (a temperature increase of the frozen food shortens its safe storage period).

Thawing food

Frozen food can be thawed in the fridge or at room temperature depending on the time available. Small food items may even be cooked from frozen; in this case cooking will take longer.

Any frozen food which is allowed to thaw accidentally should either be eaten as soon as possible or thrown away. Alternatively, if the food is uncooked and has not been completely defrosted it can be cooked and then refrozen.

Meat, fish and fruit should be thawed in the refrigerator compartment and small pieces of meat can even be cooked while still frozen, but you must ensure that it is thoroughly cooked through.

Vegetables should be directly immersed in boiling water; ready-cooked dishes can be placed directly in the oven in their aluminium wrapping.

A microwave oven is particularly suitable for thawing any type of frozen or deep-frozen food: follow the oven instructions, particularly regarding the placement of aluminium wrapping or containers in the oven.

Defrosted cooked food must never be refrozen.

Ice cube maker

Fill the ice cube trays to no more than 3/4 of their depth, to allow for expansion of the ice.

To remove the ice cubes, simply turn the knob fully as shown in Fig.

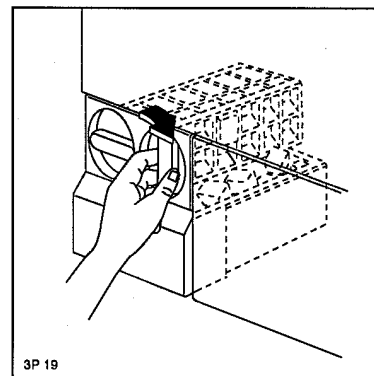

MAINTENANCE AND CLEANING

Before carrying out any maintenance operations, including those described in this book, unplug the appliance from the mains supply.

Warning

This appliance contains hydrocarbons in its cooling unit; maintenance and recharging must therefore only be carried out by authorized technicians.

Periodic cleaning

Clean the inside of the appliance and the accessories with a solution of lukewarm water and bicarbonate of soda (5 ml to 0.5 litre of water). Rinse and dry thoroughly.

The freezer compartment drawers can be removed for washing. To remove the drawers, pull them out until they reach the stop, then lift and withdraw them from the guides. To refit the drawers, engage them in the guides then, keeping them tilted, push them inwards.

Defrosting of the refrigerator

To achieve automatic defrosting of the refrigerator, the compressor must cut out from time to time. If the bottom of the compartment becomes covered with too much frost, turn the thermostat knob slowly towards a warmer setting until the compressor starts to cut out periodically.

It is important to periodically clean the defrost water drain hole in the middle of the refrigerator compartment channel to prevent the water overflowing and dripping onto the food inside. Use the special cleaner provided, which you will find already inserted into the drain hole.

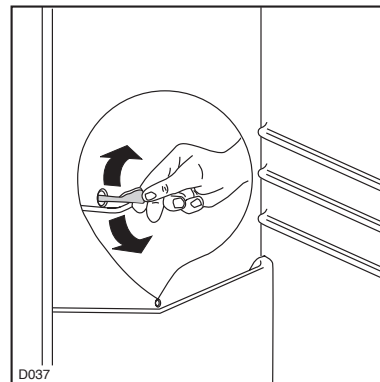

Important:

Never use sharp metal tools to scrape off frost from the evaporator as you could damage it.

Do not use a mechanical device or any artificial means to speed up the thawing process other than those recommended by the manufacturer.

Periods of non operation

If the appliance is to be out of use for some time, turn the main On/Off switch **E** to position «0», allow the appliance to defrost and thoroughly clean it. Leave the doors ajar to allow the air to circulate and so avoid the formation of unpleasant smells.

Replacing the bulbs

Refrigerator compartment

Unscrew the light cover as shown. Remove the bulb and replace with a new bulb (15 watt max).

Replace the light cover.

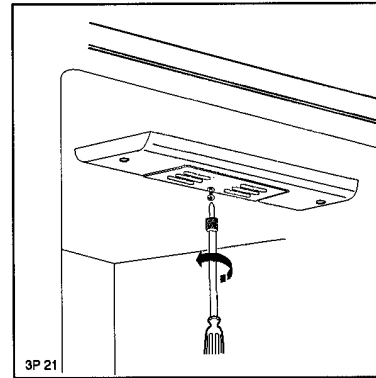

Freezer compartment

Unscrew the light cover as shown. Remove the bulb and replace with a new bulb (12 watt max).

Replace the light cover.

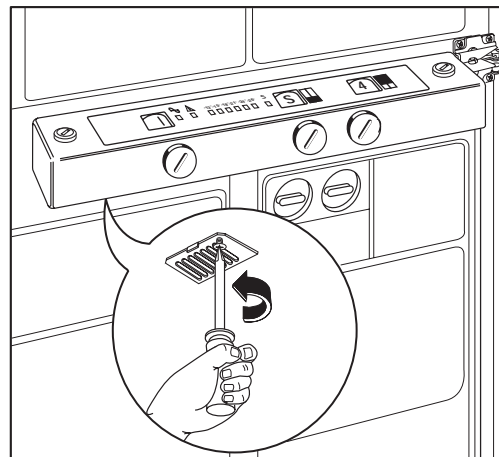

SOMETHING NOT WORKING

Important: If you call out an engineer to a fault listed below, or to repair a fault caused by incorrect use or installation a charge will be made, even if the appliance is under guarantee.

Before contacting your local Service Force Centre, check the following points:

Symptom	Solution
No power to the appliance	Check there is power at the socket.
	Check there is not a power cut by checking the household lights.
	Check the fuse has not blown.
The light does not come on	Ensure that the bulb is correctly fitted.
	Replace the bulb if it has blown.
	Check the door light switch is not jammed.
The temperature in the fridge or freezer section is too high	Check the thermostat knob in the fridge is turned to the correct setting relative to ambient conditions.
	Check the ambient temperature is within the appliance's operating limits of 10°C to 32°C.
The freezer door will not open	Has door just been opened? If so leave for a few minutes to allow the air pressure to equalise.
The compressor runs continuously	Adjust the thermostat knob to give correct temperature control. See "Setting the temperature".
	Check that the doors are closed.
	Large quantities of food have recently been placed in the cabinet and/or door is frequently opened.
	Check that air ventilation is not obstructed.
Excessive frost and ice has built up	Ensure the doors are not left open.
	Check that nothing is preventing the doors from closing.
	Is the door gasket intact and clean.
Noise	Refer to normal operating sounds.
Water under the salad bin	Check the drain hole is not blocked. (see Maintenance and Cleaning).

If, after the above checks, there is still a fault, call your local Service Force Centre.

In-guarantee customers should ensure that the above checks have been made as the engineer will make a charge if the fault is not a mechanical or electrical breakdown.

Please note that proof of purchase is required for any in-guarantee service calls.

SERVICE AND SPARE PARTS

In the event of your appliance requiring service, or if you wish to purchase spare parts, please contact your local Zanussi Service Force Centre by telephoning:-

0870 5 929929

Your telephone call will be automatically routed to the Service Force Centre covering your post code area.

For the address of your local Service Force Centre and further information about Service Force, please visit the website at www.serviceforce.co.uk

Before calling out an engineer, please ensure you have read the details under the heading 'Something Not Working?'

When you contact the Service Force Centre you will need to give the following details:

1. Your name, address and post code
2. Your telephone number
3. Clear and concise details of the fault
4. The model and serial number of the appliance (found on the rating plate)
5. The purchase date

Please note that a valid purchase receipt or guarantee documentation is required for in-guarantee service calls.

CUSTOMER CARE DEPARTMENT

For general enquiries concerning your Zanussi appliance or for further information on Zanussi products, please contact our Customer Care Department by letter or telephone at the address below or visit our website at www.zanussi.co.uk

Customer Care Department

Zanussi

55-77 High Street

Slough

Berkshire

SL1 1DZ

Tel: 08705 727 727 (*)

* calls to this number may be recorded for training purposes.

Standard guarantee conditions

We, Zanussi, undertake that if within 24 months of the date of the purchase this Zanussi appliance or any part thereof is proved to be defective by reason only of faulty workmanship or materials, we will, at our option repair or replace the same FREE OF CHARGE for labour, materials or carriage on condition that:

The appliance has been correctly installed and used only on the electricity supply stated on the rating plate.

The appliance has been used for normal domestic purposes only, and in accordance with the manufacturer's instructions.

The appliance has not been serviced, maintained, repaired, taken apart or tampered with by any person not authorised by us.

All service work under this guarantee must be undertaken by a Zanussi Service Force Centre. Any appliance or defective part replaced shall become the Company's property.

This guarantee is in addition to your statutory and other legal rights.

Home visits are made between **8.30am and 5.30pm** Monday to Friday. Visits may be available outside these hours in which case a **premium** will be charged.

Exclusions

This guarantee does not cover:

Damage or calls resulting from transportation, improper use or neglect, the replacement of any light bulbs or removable parts of glass or plastic.

Costs incurred for calls to put right an appliance which is improperly installed or calls to appliances outside the European Community (EC) or European Free Trade Area.

Appliances found to be in use within a commercial environment, plus those which are subject to rental agreements.

Products of Zanussi manufacture which are not marketed by Zanussi.

European Guarantee

If you should move to another country within Europe then your guarantee moves with you to your new home subject to the following qualifications:

The guarantee starts from the date you first purchased your product.

The guarantee is for the same period and to the same extent for labour and parts as exists in the new country of use for this brand or range of products.

This guarantee relates to you and cannot be transferred to another user.

Your new home is within the European Community (EC) or European Free Trade Area.

The product is installed and used in accordance with our instructions and is only used domestically, i.e. a normal household.

The product is installed taking into account regulations in your new country.

Before you move please contact your nearest Customer Care centre, listed below, to give them details of your new home. They will then ensure that the local Service Organisation is aware of your move and able to look after you and your appliances.

France	Senlis	+33 (0)3 44 62 29 29
Germany	Nürnberg	+49 (0)800 234 7378
Italy	Pordenone	+39 (0)0434 39 4700
Sweden	Stockholm	+46 (0)8 672 53 90
UK	Slough	+44 (0)1753 219 897

TECHNICAL SPECIFICATIONS

POWER SUPPLY VOLTAGE AND FREQUENCY	220-240 V / 50 Hz
TOTAL POWER ABSORBED	240 W
AVERAGE DAILY UNITS ELECTRICITY *	1.80 kWh

GROSS CAPACITY		
	Fridge	270 l
	Freezer	128 l
NET CAPACITY		
	Fridge	266 l
	Freezer	96 l

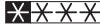
STAR RATING	
-------------	---

* This figure is based on standard test results in accordance with European Standard EN 153.
Actual consumption will depend on how the appliance is used and where it is located.

INSTALLATION



Warning

IF YOU ARE DISCARDING AN OLD APPLIANCE THAT HAS A LOCK OR CATCH ON THE DOOR, YOU MUST ENSURE THAT IT IS MADE UNUSABLE TO PREVENT YOUNG CHILDREN BEING TRAPPED INSIDE.

Positioning

This appliance should only be installed at a location where the ambient temperature corresponds to the climate classification indicated on the rating plate, which is located on the inside left of the appliance.

The following table shows which ambient temperature is correct for each climate classification.

SN +10°C to +32°C

ST +18°C to +38°C

The appliance should be located in a dry atmosphere, out of direct sunlight and away from continuous heat and extreme temperature, e.g. not next to a boiler or radiator, or in a very cold room e.g. an outhouse. If these temperatures are exceeded i.e. warmer or colder, then the appliance may not operate correctly.

For building-in instructions please refer to the instructions on the following pages.

Important

It must be possible to disconnect the appliance from the mains power supply; the plug must therefore be easily accessible after installation.

Electrical connections

Any electrical work required to install this appliance should be carried out by a qualified electrician or competent person.

WARNING: THIS APPLIANCE MUST BE EARTHED.

The manufacturer declines any liability should this safety measure not be observed.

If the plug that is fitted to your appliance is not suitable for your socket outlet, it must be cut off and the appropriate plug fitted.

Remove the fuse from the cut off plug.

The cut off plug should then be disposed of to prevent the hazard of shocks in case it should be plugged into a 13amp socket in another part of your home.

Important

The wires in the mains lead are coloured in accordance with the following code:

Green and Yellow - Earth

Blue - Neutral

Brown - Live

If you fit your own plug, the colours of the wires in the mains lead of your appliance may not correspond with the markings identifying the terminals in your plug, proceed as follows:

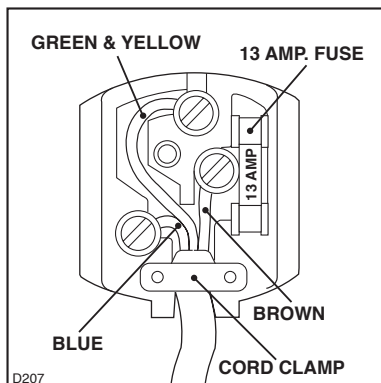

Connect the Green and Yellow (earth) wire to the terminal in the plug which is marked with the letter «E» or the earth symbol  or coloured green and yellow.

Connect the blue (neutral) wire to the terminal in the plug which is marked with the letter «N» or coloured black.

Connect the brown (live) wire to the terminal in the plug which is marked with the letter «L» or coloured red.

The plug moulded onto the lead incorporates a fuse. For replacement, use a 13amp BSI362 fuse. Only ASTA or BSI approved fuses should be used.

The plug must not be used if the fuse cover/carrier is lost. The cover/carrier is indicated by the coloured insert at the base of the plug.

A replacement cover/carrier must be obtained from your local Zanussi Service Force Centre.

This appliance complies with the E.E.C. Directive No. 87/308 of 2.6.87 relative to radio interference suppression.

 This appliance complies with the following E.E.C. Directives:

- **73/23 EEC of 19.2.73** (Low Voltage Directive) and subsequent modifications;
- **89/336 EEC of 3.5.89** (Electromagnetic Compatibility Directive) and subsequent modifications.

Please ensure that when the appliance is installed it is easily accessible for the engineer in the event of a breakdown.

POSITIONING

Height adjustment

The height of the appliance is adjustable from 820 to 870 mm to line up with existing kitchen units.

Before installing the appliance between units, adjust the height of the feet and rear wheels. The wheels are factory set for a height of 820 mm. To align the appliance to a height of 870 mm, raise it by adjusting the feet with a spanner, then remove the wheels and refit them in the lowest position.

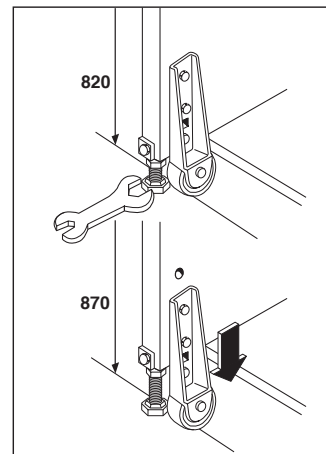
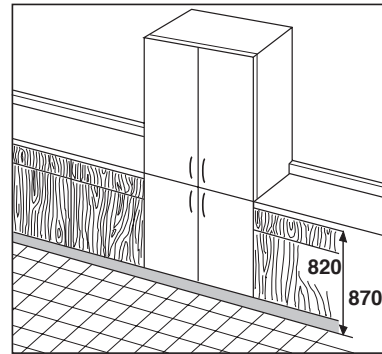

Fitting the side panels

- Fit the brackets onto the panels in the positions shown in the diagram. The dimension of 132 mm is allowed for fitting a 100 mm plinth below the panel. For different plinth sizes, reduce or increase the dimension of 132 mm accordingly.

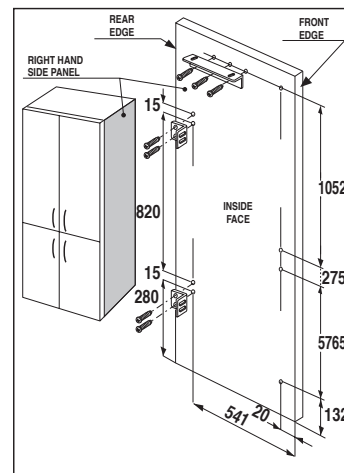

- Rest the panels against the appliance.
- Fit the rear brackets, taking into account the thickness of the panels (maximum width of unit 900 mm).
- Secure the panels at the front. If using panels less than 20 mm thick, fit spacer plates C, supplied with the appliance, on the hinge side.

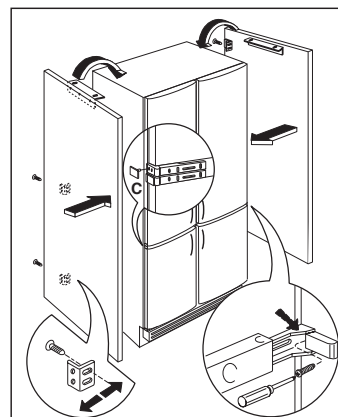

Building the appliance in

- Fit the appliance into the recess.
- Fix it to the wall with the appropriate bracket.

- The top of the appliance must be kept clear to allow correct air circulation. If a wall unit is fitted above the appliance, there must be a gap of 50 mm between this unit and the wall and it must be at least 50 mm below the ceiling.

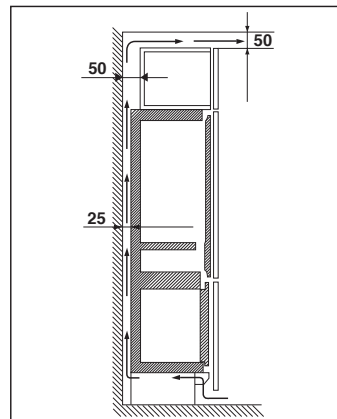
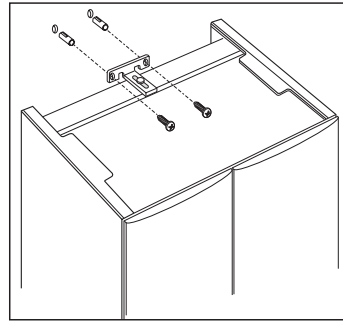

Fitting the plinth

Alignment height of 820 mm

- If using a 140 to 170 mm plinth, make a cut-out as shown.

- If using a plinth higher than 100 mm but less than 140 mm, cut the height compensation strip supplied with the appliance to the required depth and fit it between the plinth and the ventilation grille, pressing it into position below this grille.

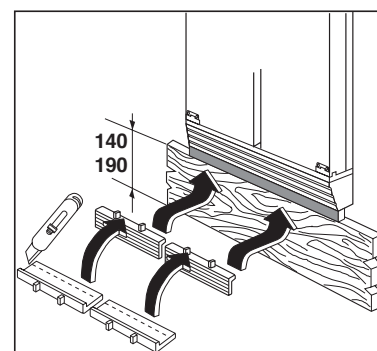
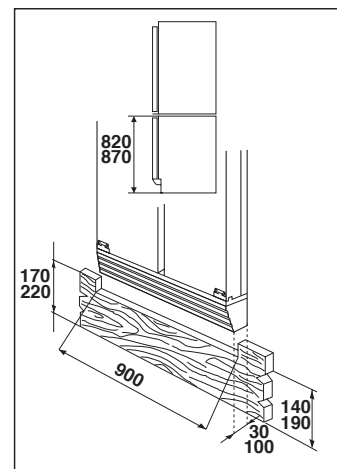

- If using a 100 mm plinth, fit the complete height compensation strip.

Alignment height of 870 mm

- If using a 190 to 220 mm plinth, make a cut-out as shown.
- If using a plinth higher than 150 mm but less than 190 mm, cut the height compensation strip supplied with the appliance to the required depth and fit it between the plinth and the ventilation grille.
- If using a 150 mm plinth, fit the complete height compensation strip.

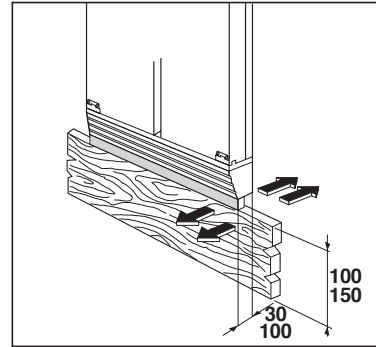

- If the appliance is installed at the end of a row of units, insert foot E to hold the plinth in place.

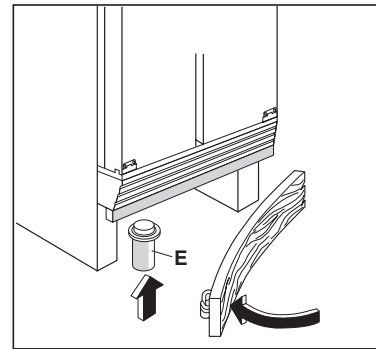

© Electrolux Household Appliances Limited 2002

 **From the Electrolux Group. The world's No. 1 choice.**

The Electrolux Group is the world's largest producer of powered appliances for kitchen, cleaning and outdoor use. More than 55 million Electrolux Group products (such as refrigerators, cookers, washing machines, vacuum cleaners, chain saws and lawn mowers) are sold each year to a value of approx. USD 14 billion in more than 150 countries around the world.