

# ZANUSSI

The Electrolux logo consists of a blue square icon with a white stylized 'E' inside, followed by the word 'Electrolux' in a blue, sans-serif font. A blue curved line arches over the logo.

**Electrolux**

**ZFC 326 WB**  
**ZFC 340 WB**  
**ZFC 350 WB**  
**ZFC 330 WB**  
**ZFC 321 WB**

## **USER MANUAL**

EN

### Disposal

By ensuring this product is disposed of correctly, you will help prevent potential damaging consequences for the environment and human health.

 The symbol on the product indicates that this product may not be treated as household waste. Instead it should be taken to an appropriate collection point for the recycling of electrical and electronic equipment. For more detailed information about recycling of this product, please contact your local council, your household waste disposal service or the shop where you purchased the appliance.

### Safety Information

Before installing and using the appliance read this user's instruction book carefully. It contains safety precautions, hints, information and ideas. If the freezer is used in compliance with these instructions, it will operate properly and provide you with the greatest satisfaction.

These warnings are provided in the interest of safety. You must read them carefully before installing or using the appliance.

- Use the freezer only for storing frozen food, freezing fresh food and making ice cubes.
- Do not eat ice cubes or ice lollies immediately after taking them out of the freezer, as they may cause frost burns.
- Do not allow children to play or hide inside the freezer, as they may become trapped inside and suffocate.
- Do not store glass containing liquids in the freezer, as they may burst.
- Ensure that the freezer is not resting on the power supply cable.
- Before servicing or cleaning, always unplug the appliance or disconnect from the power supply.
- Do not use other electrical appliances (such as ice cream makers) inside the appliance.
- Your appliance contains an environmentally friendly natural gas, isobutane (R600a). Caution is required however, as isobutane is flammable. Therefore it is essential to ensure that the refrigerant pipelines are not damaged.

It is most important that this instruction book should be retained with the appliance for future reference.

### Product Description

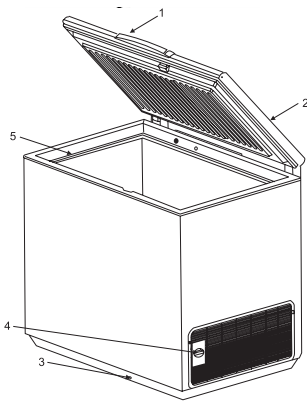

1. Lid handle
2. Seal
3. Defrost water drain
4. Thermostat knob: temperature adjustment
5. Upper edge

### Installation

- Wait at least 2 hours before connecting the freezer to the power supply to ensure the refrigerant circuit is fully efficient.
- Install the freezer in a dry, well ventilated room. Avoid locations near a source of heat or in direct sunlight.
- The room temperature should correspond to the climatic classification for which the freezer was designed, see chapter "Technical data".
- Place the freezer horizontally on a firm surface, resting on all four feet.
- For optimum operation and in order to avoid damage when the lid is opened, leave a space of at least 5 cm from the rear wall and 5 cm at the sides.
- Before connecting the freezer to the power supply, ensure that the voltage corresponds to that indicated in chapter "Technical data" under "Voltage".

### Danger!

- Ensure that the freezer is not resting on the power supply cable.
- Do not remove the power supply cable by pulling on its lead, particularly when the freezer is being pulled out of its niche.
- The power supply cable may only be replaced by a qualified electrician.
- Ensure that the power plug is not squashed or damaged by the back of the freezer.
- There must be adequate ventilation around the appliance.
- Any electrical work required to install this appliance should be carried out by a qualified electrician.

## Electrical connection

The appliance is supplied with a 13amp plug fitted. In the event of having to change the fuse in the plug supplied, a 13amp ASTA approved (BS1362) fuse must be used. Should the plug need to be replaced for any reason. The wires in the power supply cable are coloured in accordance with the following code:

- Green and Yellow - Earth: must be connected to the terminal marked with the letter "E" or by the earth symbol or coloured green and yellow.
- Blue - Neutral: must be connected to the terminal "N" or coloured black.
- Brown - Live: must be connected to the terminal marked "L" or coloured red.

Upon completion there must be no cut, or stray strands of wire present and the cord clamp must be secure over the outer sheath.

 **Warning!** This appliance must be earthed.

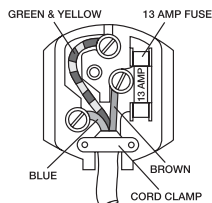



## First use

- Before first use, the freezer should be cleaned inside, see chapter "Care and cleaning".
- Plug in the appliance and allow the freezer to run for several hours before placing food inside.

## Switch on-off

### Switch on the freezer

- Turn the thermostat knob to a position between  and .

### Switch off the freezer

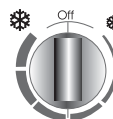

- Turn the thermostat knob to the Off position.



## Daily use

### Temperature adjustment

To adjust the temperature of the freezer, proceed as follows:

- Turn the thermostat knob clockwise towards  for a colder storage temperature.
- Turn the thermostat knob counter-clockwise towards  for a less cold storage temperature.

### Storage baskets

- Hang the baskets on the upper edge (X) or place the stackable baskets inside the freezer (Y).
- Turn and fix the handles for these two positions, as shown in the drawings.

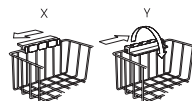

Spare baskets can be obtained from your local Service Force Centre or from the Electrolux website (depending on country). The illustrations on this page show how many baskets can be placed in the various freezer models.



## Opening and closing the lid

As the lid is fitted with a tightly closing seal, it will not re-open easily immediately after closing.

- Wait a few minutes before re-opening the lid. Never pull the handle with immense force.

## Care and Cleaning

### Defrosting the freezer

When the ice layer is 10-15 mm thick, the freezer should be defrosted. We suggest that you defrost your freezer when there is little or no food inside.

- Disconnect the appliance from the power supply.
- Remove the contents of the freezer, wrap them in newspapers, and keep them in a cold place.
- Leave the appliance lid open.
- Remove the plug from the water drain.
- The defrost water can be collected in a tray as shown in the drawing. If available, use the divider.
- Speed up defrosting by using the enclosed scraper to detach the ice from the appliance walls.
- Dry the interior of the appliance thoroughly.
- Remember to replace the plug in the water drain.

**Important!** Never use a knife or any other sharp implement to remove frost or ice.

## Cleaning

The best time to clean your freezer is after defrosting.

- Disconnect the appliance from the power supply and remove all loose accessories.
- Use a damp cloth to clean your freezer. Use hot water and a mild, non-aromatic detergent.
- Clean the loose accessories, before replacing them again.

**Important!** Never use strong detergents, scouring powder or aromatic detergents to clean your freezer.

### When not in use

- Disconnect the appliance from the power supply.
- Remove all food from the freezer.
- Clean the freezer as described above.
- Leave the lid slightly open.

### Helpful hints and tips

#### Freezing food

- Before freezing, fresh food must be packed in airtight and moisture-proof packaging to prevent it from drying out.
  - Only use fresh food of the best quality.
  - Always leave hot food to cool to room temperature before placing in the freezer.
  - Divide food into small portions before freezing; this ensures that freezing is more rapid, and that you only need to defrost the amount needed for immediate consumption.
  - Mark the freezer packaging with the date of freezing.
  - Place fresh food for freezing close to the cold sides of the freezer, making sure that it is not in contact with the frozen food already in the freezer.
  - Frozen food can be stored anywhere inside the freezer, but should be kept at least 5 mm below the upper edge.
- If freezing is too slow, the quality of the food being frozen deteriorates. The amount of fresh food (expressed in kg) that can be frozen in 24 hours is indicated in the chapter "Technical data" under "Freezing capacity".

#### Food storage

- For fresh frozen food, please refer to the storage period table underneath.
- For purchased frozen food, never exceed the expiry date.
- When you buy frozen food, make sure that it has been stored at the correct temperature. Do not buy products which have wet or damaged packaging. Place purchased products in your freezer as quickly as possible. We recommend using an insulated bag to bring such products home with you.

**Important!** Remember that fully or partially defrosted food must not be re-frozen. However, dishes which have been cooked using defrosted food may be frozen.

#### In the case of a power failure or breakdown

- Do not open the lid.

**Important!** If the power has been off for longer than the value shown in the chapter "Technical data" under "Hold-over time", the defrosted food must be consumed quickly or cooked immediately and then refrozen (after cooling).

#### What to do if...

Try the solutions suggested here first to avoid the cost of an unnecessary service call.

##### Your freezer will not operate

- Is the power supply cord unplugged?
- Has a household fuse blown?
- Is there a power failure?
- Is the temperature control set to the Off position?

##### The motor seems to run too much

- Is the lid not closed completely? Check for obstructions.
- Is the room temperature hotter than normal?
- Has a large amount of fresh food just been added to the freezer?
- Is the lid opened often?
- Is the temperature control set correctly for the surrounding conditions?
- Is the lid seal damaged or deformed?
- Is there enough air circulation space around the freezer?

##### Temperature is too warm

- Has a large amount of food just been added to the freezer?
- Is the lid opened often?
- Is the temperature control set correctly for the surrounding conditions?

##### Too much ice has formed

- Is the lid not closed completely? Check for obstructions.
- Is the water drainage plug correctly positioned?

##### The lid will not close completely

- Is there excessive frost or a package preventing the lid from closing?
- Are food packages blocking the lid?
- Is the lid seal dirty or sticky?
- Does the freezer wobble or seem unstable?

**The lid is difficult to open**

- Is the lid seal dirty or sticky?

If you still need help, please contact your local Service Force Centre.

**Service or repair**

In cases of breakdown or faults, your freezer must be serviced by an authorized Electrolux Service engineer.

**Important!** Under no circumstances should you attempt to repair the appliance yourself.

**Technical Data**

Model		BNI280	BNI425	BNI525	BNI325	BNI225
		ZFC326WB	ZFC340WB	ZFC350WB	ZFC330WB	ZFC321WB
Volume (gross)	Litre	263	404	500	304	213
Volume (net)	Litre	260	400	495	300	210
Height	cm	87,6	87,6	87,6	87,6	87,6
Width	cm	93,5	132,5	160	105	79,5
Depth	cm	66,5	66,5	66,5	66,5	66,5
Weight net	kg	44	56	66	49	39
Energy consumption 24 Stunden	kWh/24 h	0,878	1,152	1,338	0,957	0,78
Freezing capacity	kg/24 h	16	19	20	17	14
Hold-over time	Hours	32	31	31	32	28
Rated power	Watt	100	100	140	100	100
Voltage	Volts	230	230	230	230	230
Climatic class		SN-T	SN-T	SN-T	SN-T	SN-T

Climatic classification	Ambient temperature limits
SN	from +10°C to +32°C
N	from +16°C to +32°C
ST	from +18°C to +38°C
T	from +18°C to +43°C

This appliance complies with the following EC Directives:



73/23/EEC of 19. 02. 1973 Low-Voltage Directive

89/336/EEC of 03. 05. 1989 (including Amendment Directive 92/31/EEC - EMC Directive)





[www.zanussi - electrolux.co.uk](http://www.zanussi-electrolux.co.uk)