

Use and Care Guide

To help you get the most from your new freezer

Before you freeze the first apple pie, you will want to know all about your new Whirlpool freezer. That's what this Use and Care Guide is all about. It tells you how to start it, fill it, clean it... even what to do if anything goes wrong. See handy Self-service Check List on back page of simple problems you can solve yourself without the wasted time and possible expense of a needless service call. After all, who needs a service technician to plug back in an electric cord that's been accidentally pulled out?

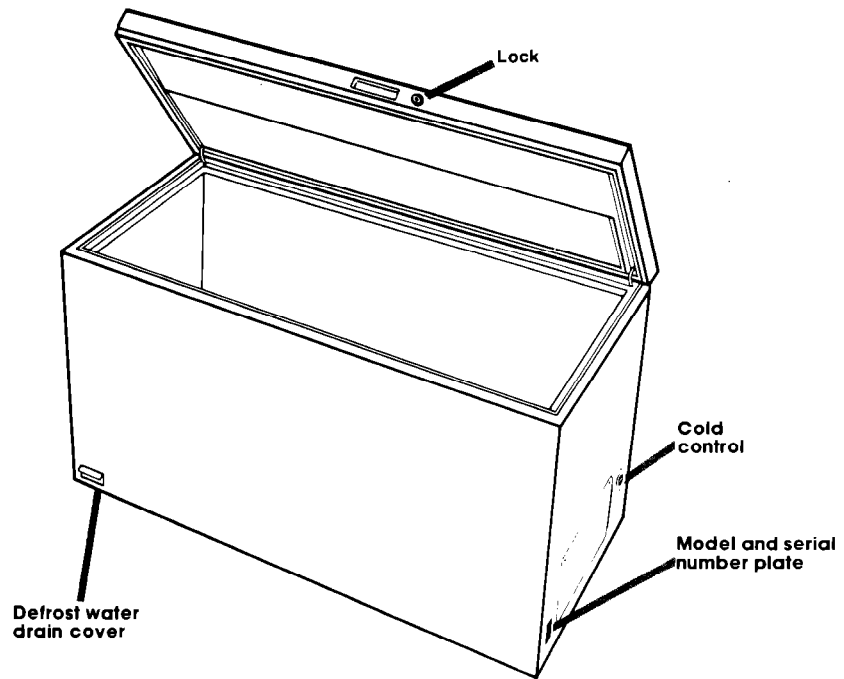

Safety first Prevent child entrapment

Please read the safety booklet from the Association of Home Appliance Manufacturers that is packed in your freezer. Help prevent accidents if you plan to abandon or "junk" an old freezer.

Before you use your freezer

- Be sure your freezer is properly installed in an appropriate level area and a place suitable for the size, function and protection of the freezer.
- Properly connect to electricity.
- Remove the Consumer Buy Guide Label before freezer is used.
- Remove the defrost drain cover

from the literature package located inside your freezer. Install that cover as shown in the above illustration.

- Do not permit children to operate or play with the freezer.
- **REMEMBER:** Use the appliance only for the job it was designed to perform.

Energy saving tips

- Check lid gaskets for tightness of seal. If freezer has a lock, keeping it locked can help insure door closure and good seal. Level cabinet properly to assure a good door seal.
- Keep lid openings to a minimum. Remove as many items at one time as possible. Keep foods organized to eliminate searching.
- Fill to capacity. However, do not add too much unfrozen food at one time. Follow recommended loading procedures.

- Frost should not build up to more than ¼-inch (6 mm) thick (reduces efficiency).
- Set cold control to provide the right degree of cold temperature. Temperature should be about 0°F (-22°C). There is no need to store foods below 0°F.
- Do not locate freezer next to or near a heat source, such as a range, water heater, furnace, etc.

(See booklet, How to Preserve Foods the Modern Way with Your WHIRLPOOL Freezer, for complete information and tips on home freezing.)

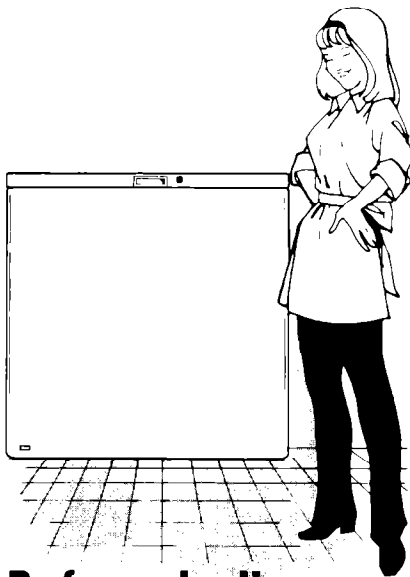

Before starting your freezer

1. Locate it properly – For top performance, locate your freezer in a cool, dry, well-ventilated place out of direct sunlight and away from such heat sources as radiators. **Pick a safe place, indoors, away from inflammables such as gasoline.** For proper air circulation allow at least two inches (5 cm) of air space at the back and three inches (7.5 cm) at the sides of the freezer. Do not cover the freezer with such items as blankets, sheets, tablecloths, etc. Check the strength of the floor, make certain it can support the weight of the freezer when it is loaded. It should not be necessary to remove the lid during installation. If, for any reason, the hinges need adjustment, see your authorized WHIRLPOOL dealer.

2. Keep it level – Level freezer from end to end and from front to back so that the lid will seal properly. With the lid open, lay a spirit level on the edge of the freezer at the end and the front of the cabinet. If it is necessary to level cabinet, use wood shims. Do not use cardboard or other soft material.

3. Cleaning – Before starting, wash the interior with a solution of two tablespoons (26 g) of baking soda to one quart (.95 L) of warm water. Rinse and dry. Wash outside of freezer with warm water and mild soap or detergent, rinse thoroughly and dry.

NOTE: Do not use an abrasive or harsh cleanser. Cleaning waxes, concentrated detergents, bleaches and cleansers containing petroleum products should not be used to clean plastic parts of the freezer.

To start freezer

Electrical Connection – Your freezer should be connected to its own individual receptacle, one not controlled by a wall switch. Make sure the receptacle provides 120 volt, 15 amp, 60 Hz AC current. For your safety, the power supply cord of the freezer is equipped with a three-pronged grounding plug. It should be plugged into a matching grounded three-pronged type wall receptacle. Attach retaining clip for cord plug. **Do not remove the ground prong.** See electrical requirements and grounding instructions sheet for complete information.

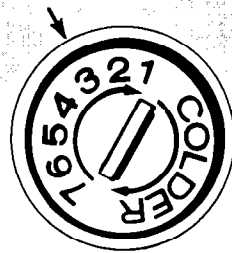

Set cold control – Insert a coin in the slot of the control to turn it. To start, turn cold control to Number 3. This position will maintain zero zone temperatures under normal operating conditions. Turn the cold control to a higher number for colder temperatures or a lower number for less cold temperatures.

Let freezer cool before filling – Allow freezer to cool 6 to 8 hours before filling with frozen food. Let it cool overnight before adding a quantity of food to be frozen.

NOTE: When freezer first starts, the motor will run all the time until the cabinet is cooled to a safe storage temperature. This first cooling may take 6 to 8 hours or longer, depending upon the weather and number of times the freezer lid is opened. After the cabinet is cooled, the motor turns off. It will then turn on and off as needed to keep the freezer at a safe storage temperature.

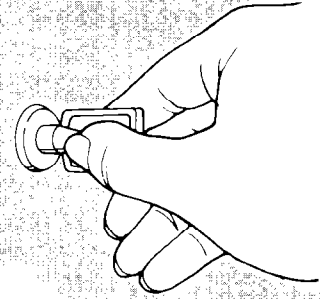

Your freezer is equipped with a key eject lock which can help reduce the hazard of child entrapment. To lock or unlock the freezer it is necessary to manually hold the key in the lock while turning. The lock is spring loaded so the key cannot be left in the lock. If key is lost, a replacement can be obtained from your dealer or a Whirlpool TECH-CARE® service agent. Always give complete model and serial numbers of your freezer when requesting a replacement key.

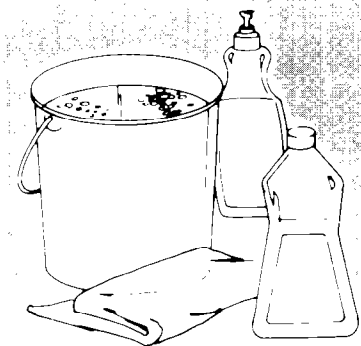

Taking care of your freezer

Defrosting and cleaning

When frost has built up to about ¼-inch (6 mm) thickness, it is time to defrost. Use a plastic scraper.

Do not use an ice pick, knife or other sharp-pointed tool as it could damage the liner of the freezer.

How to freeze food in your freezer

PACKAGE AND SEAL CAREFULLY

Airtight packaging is the secret of success in freezing foods. Containers and wrappings should be moisture-vapor-proof and packages should be sealed carefully to keep natural moisture in and air out.

If food is not properly wrapped, freezer burn will result. When this happens, food dehydrates and is of poor quality.

The drugstore fold is recommended for efficiency and economy. Bring the edges of the paper together and fold over until it fits tightly around the articles being wrapped (at least two folds).

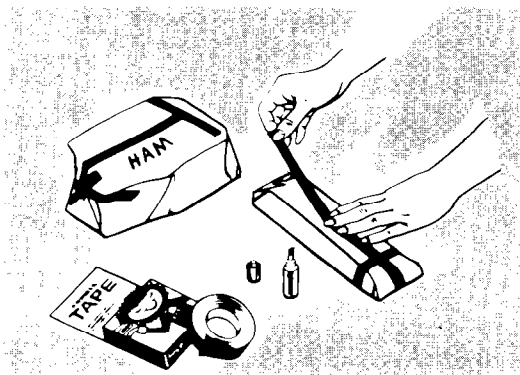
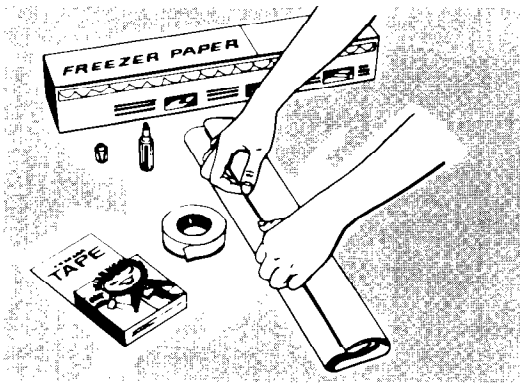

Heavy-duty aluminum freezer foil, kraft paper with cellophane bonded to it, special freezer bags, jars, cartons and special pressure-sensitive freezer sealing tape are available at your supermarket or freezer dealer. See your "How to Freeze Book" for packaging material guide.

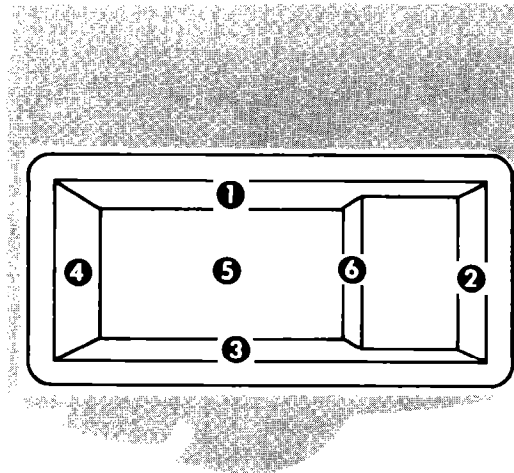

Loading

Before loading with unfrozen food, turn cold control to coldest position (highest number) and let freezer operate for several hours. This will speed up the rate of freezing. Lay packages to be frozen in a single layer so each rests on a freezing surface. (See illustration above.) Allow space between packages for cold air to circulate.

Food will be frozen in about 18 to 24 hours, depending upon the kind of food, size and shape of the package and the amount to be frozen. Do not add more **unfrozen** food until previous load is frozen. If in doubt, wait 24 hours before adding more unfrozen food.

When food is frozen, return cold control to its usual setting.

Storing frozen food

When food is frozen, stack packages anywhere in the freezer. Make sure that packages do not extend above the top of the cabinet, keeping lid from closing.

How to freeze food in your freezer

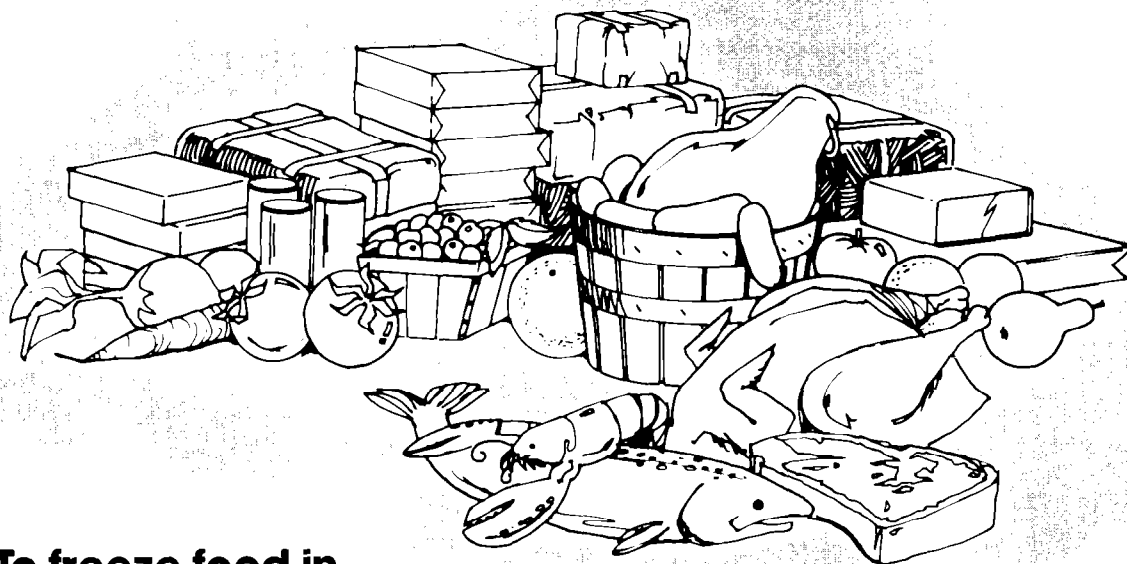

To freeze food in your freezer

When freezer has cooled to a safe storage temperature, it may be loaded with **frozen food**. However, when you plan to freeze a quantity of unfrozen food, see the following chart for the amount to freeze at **one time**.

POUNDS OF FOOD TO FREEZE AT ONE TIME*

Size of Freezer	Meat or Fish	Vegetables or Fruit
15 cu. ft. (433 L)	30 (13.5 kg)	45 (20.25 kg)

*These amounts are based on USDA recommendations. If too many packages of unfrozen food are packed at one time into the freezer, the rate of freezing is too slow. Poor quality products result.

Caution: Do not use any type of electric defroster to speed the defrosting of the freezer. The heat can cause damage to some of the interior parts.

Complete defrosting and cleaning should be done at least once a year. In high humidity areas, a freezer may need more frequent defrosting. Follow these steps:

1. Disconnect service cord from wall outlet.

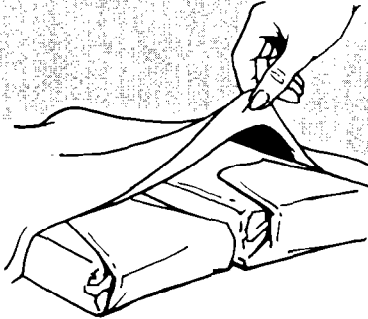

2. Remove frozen foods and wrap packages individually in several thicknesses of newspaper and cover with a blanket. Food handled this way will stay frozen several hours.
3. Connect defrost water drain – remove drain cover...pull out. Insert hose adapter provided into drain outlet. Remove rubber stopper from inside bottom of freezer. Place a flat pan under the drain, or attach a hose to the threaded portion of the adapter and direct the water into a convenient drain.
4. Speed the melting of the frost by placing pans of hot water inside the freezer; or directing air from an electric fan into the freezer; or using a garden hose to wash the inside with warm water.
5. Wash inside of freezer with a solution of two tablespoons (26 g) of baking soda to one quart (.95 L) of warm water. Rinse and dry. Wash the gasket strip around the lid and trim strip around the top of the cabinet with warm, soapy water. Rinse and dry. Wash outside of freezer with warm, soapy water. Rinse and dry.

6. Remove hose adapter. Replace drain cover and rubber stopper.
7. Plug service cord back into wall outlet.

NOTE: Cleaning waxes, concentrated detergents, bleaches and cleansers containing petroleum products should not be used to clean the lid gasket or plastic parts of the freezer.

Vacation and moving care



When you take a vacation

Arrange to have a periodic check of your freezer to make sure it is operating and electricity to freezer has not been interrupted.

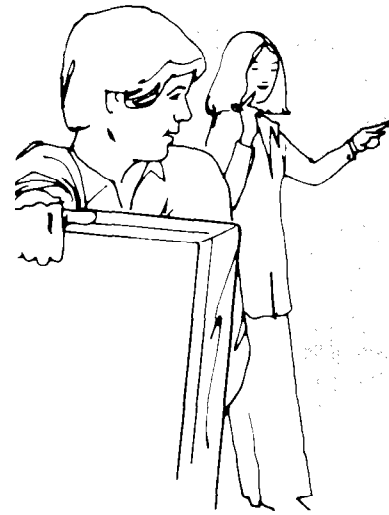

Shutting off or moving freezer

If you shut the freezer off for a period of time (more than 24 hours):

- Remove all food.
- Unplug freezer.
- Clean thoroughly, using two tablespoons (26 g) of baking soda to one quart (.95 L) of warm water. Rinse and dry.
- Block lid open so air can circulate freely to prevent odor and mold growth. Place rubber or wood blocks between lid and cabinet. Tape blocks securely in place using self-adhesive filament tape (strapping tape).

If you move the freezer:

- Remove all food, unplug freezer and clean thoroughly.
- Do not place heavy objects inside or on top of freezer as damage may result.
- Level freezer when relocated to insure lid sealing.

CAUTION: To help prevent accidents, do not allow children to have access to the freezer when the door is blocked open.

If you need service or help, we suggest you follow these three steps:

1. Before calling for service...

Performance problems often result from little things you can find and fix yourself without tools of any kind.

If electricity goes off

Learn how long power will be off by calling the power company.

1. If service is to be interrupted 24 hours or less, keep freezer closed. Most food will stay frozen.
2. If service is to be interrupted longer than 24 hours, do this:
 - (a) Remove all frozen food and store in a frozen food locker. Or...
 - (b) Place dry ice on top of food, using as large pieces as possible. Protect your hands with gloves when using dry ice.
 - (c) If neither food locker storage nor dry ice is available, use or can perishable food at once.
3. The length of time food will stay frozen depends on several factors. For instance: a full freezer will remain cold longer than a freezer only partially filled. And a freezer full of meat will stay cold longer than a freezer filled with baked goods. Also, if the food still contains ice crystals, it may be safely refrozen, although the quality and flavor may be affected. Use this food as soon as convenient. If the condition of the food is poor or is in any way questionable, it is wise to dispose of it.

If freezer stops running

1. Check to see if power cord is plugged into the outlet.
2. Check fuse box or circuit breaker.
3. Check electric company for a power failure.

If motor seems to run too long

1. If large amounts of unfrozen food have been put into the freezer, motor will run longer.

2. On hot summer days or if room is hot, motor will run longer to provide correct amount of cooling.

If frost builds up on the trim strip around top of cabinet

1. Check the fit of the lid to make sure it is sealing. With the lid closed, press down firmly on the edges or at the center of the lid. This pressure will cause the flexible lid to fit flat against the cabinet and seal.
2. Do not open or close the lid by grasping a corner. Use the handle.

2. If you need service...

Whirlpool Franchised TECH-CARE Service...



SYMBOL OF QUALITY SERVICE

It is reassuring to know that Whirlpool stands behind your new appliance with its network of franchised TECH-CARE® service companies. TECH-CARE service is designed to fulfill your warranty and provide the after-warranty service and maintenance to keep your new appliance in top notch condition, anywhere in the United States. Whirlpool wants you to get the service that you would expect on quality home appliances.

If you move...

To make sure that your appliance is correctly installed and to insure its continued satisfactory operation, please telephone your nearest TECH-CARE service company for installation or to get the name of a qualified installer. (Installation cost will, of course, be paid by you.)

Or, if you need service...

1. Call the dealer from whom you purchased the appliance or a Whirlpool franchised TECH-CARE service company.

He is in the Yellow Pages of your telephone directory listed under Refrigerators and Freezers – Repairing or Servicing. (Also under Washers, Dryers – Repairing or Servicing.)

2. Should you not find a listing, dial free, the Whirlpool COOL-LINE® service assistance telephone number (800)

253-1301. When calling from:

Michigan (800) 632-2243

Alaska &

Hawaii (800) 253-1121

3. If you have a problem...

Call Whirlpool Corporation in Benton Harbor at the COOL-LINE service assistance telephone number (see Step 2) or write:

Mr. Stephen E. Upton

Vice President

Whirlpool Corporation

Administrative Center

2000 U.S. 33, North

Benton Harbor, Michigan 49022

Remember... If you must call or write, please provide: your name, address, telephone number, type of appliance, brand, model, serial number, date of purchase, the dealer's name, and a complete description of the problem. This information is needed in order to better respond to your request for assistance.

Helpful Hint... The model and serial number plate is located on the lower right side corner of the freezer (see illustration on front page).

FSP® is a registered trademark of Whirlpool Corporation for quality parts. Look for this symbol of quality whenever you need a replacement part for your Whirlpool appliance. FSP replacement parts

will fit right and work right, because they are made to the same exacting specifications used to build every new Whirlpool appliance



Whirlpool

CORPORATION

Benton Harbor, Michigan Automatic Washers, Clothes Dryers, Freezers, Refrigerator Freezers, Ice Makers, Dishwashers, Built-in Ovens and Surface Units, Ranges, Microwave Ovens, Compactors, Room Air Conditioners, Dehumidifiers, Central Heating and Air Conditioning Systems