

Models 340, 341, 342

Slush Freezers

Operating Instructions

028764-M



Complete this page for quick reference when service is required:

Taylor Distributor: _____

Address: _____

Phone: _____

Service: _____

Parts: _____

Date of Installation: _____

Information found on the data label:

Model Number: _____

Serial Number: _____

Electrical Specs: Voltage _____ Cycle _____

Phase _____

Maximum Fuse Size: _____ A

Minimum Wire Ampacity: _____ A

© January, 1997 Taylor
All rights reserved.
028764-M



*The word Taylor and the Crown design
are registered trademarks in the United States
of America and certain other countries.*

Taylor Company
a division of Carrier Commercial Refrigeration, Inc.
750 N. Blackhawk Blvd.
Rockton, IL 61072



Table of Contents

Section 1	To the Installer	1
	Water Connections	1
	Air Cooled Units	1
	Electrical Connections	1
Section 2	To the Operator	2
	Compressor Warranty Disclaimer	2
Section 3	Safety	3
Section 4	Operator Parts Identification	4
Section 5	Important: To the Operator	9
	Control Switch	9
	Consistency Control	9
	Indicator Light - "Mix Low"	9
	For Your Information	9
Section 6	Operating Procedures	10
	Assembly	10
	Sanitizing	14
	Priming	15
	Closing Procedure	16
	Draining Product From the Freezing Cylinder	17
	Rinsing	17
	Cleaning	18
	Disassembly	19
	Brush Cleaning	19
Section 7	Important: Operator Checklist	20
	During Cleaning and Sanitizing	20
	Troubleshooting Bacterial Count	20
	Regular Maintenance Checks	20
	Winter Storage	21
Section 8	Troubleshooting Guide	22
Section 9	Parts Replacement Schedule	25
Section 10	Parts List	26
	Wiring Diagrams	32

Note: Continuing research results in steady improvements; therefore, information in this manual is subject to change without notice.

Section 1

To the Installer

This machine is designed for indoor use only.



DO NOT install the machine in an area where a water jet could be used to clean or rinse the machine. Failure to follow this instruction may result in serious electrical shock.

Water Connections (Water Cooled Units Only)

An adequate cold water supply with a hand shut-off valve must be provided. On the underside of the base pan, two 3/8" I.P.S. (for single-head units) or two 1/2" I.P.S. (for double-head units) water connections for inlet and outlet have been provided for easy hook-up. 1/2" inside diameter water lines should be connected to the machine. (Flexible lines are recommended, if local codes permit.) Depending on local water conditions, it may be advisable to install a water strainer to prevent foreign substances from clogging the automatic water valve. There will be only one water "in" and one water "out" connection for both double-head and single-head units. **DO NOT** install a hand shut-off valve on the water "out" line! Water should always flow in this order: first, through the automatic water valve; second, through the condenser; and third, through the outlet fitting to an **open trap drain**.

Air Cooled Units

The model 340 air cooled unit requires a minimum of 6" (152 mm) of clearance around both sides of the freezer. It is recommended to install a skirt to one side of the unit, and to place the back of the unit against a wall. The models 341 and 342 air cooled units require a minimum of 3" (76 mm) of air clearance around all sides.

Failure to allow adequate clearance can reduce the refrigeration capacity of the freezer and possibly cause permanent damage to the compressor.

Electrical Connections

Each freezer requires one power supply for each data label. Check the data label(s) on the freezer for fuse,

circuit ampacity and electrical specifications. For proper power connections, refer to the wiring diagram provided inside of the electrical box.

In the United States, this equipment is intended to be installed in accordance with the National Electrical Code (NEC), ANSI/NFPA 70-1987. The purpose of the NEC code is the practical safeguarding of persons and property from hazards arising from the use of electricity. This code contains provisions considered necessary for safety. Compliance therewith and proper maintenance will result in an installation essentially free from hazard!

In all other areas of the world, equipment should be installed in accordance with the existing local codes. Please contact your local authorities.

Stationary appliances which are not equipped with a power cord and a plug or other device to disconnect the appliance from the power source must have an all-pole disconnecting device with a contact gap of at least 3 mm installed in the external installation.



CAUTION: THIS EQUIPMENT MUST BE PROPERLY GROUNDED! FAILURE TO DO SO CAN RESULT IN SEVERE PERSONAL INJURY FROM ELECTRICAL SHOCK!

Beater rotation must be clockwise as viewed looking into the freezing cylinder.

Note: The following procedures should be performed by a trained service technician.

To correct rotation on a three-phase unit, interchange any two incoming power supply lines at the freezer main terminal block only.

To correct rotation on a single-phase unit, change the leads inside the beater motor. (Follow the diagram printed on the motor.)

Electrical connections are made directly to the terminal block. The terminal block is provided in the main control box located under the upper left side panel on counter models or behind the service panel on console models.

Section 2

To the Operator

The freezer you have purchased has been carefully engineered and manufactured to provide dependable operation. The Taylor Slush Models 340, 341, and 342, when properly operated and cared for, will produce a consistent quality product. Like all mechanical products, these machines will require cleaning and maintenance. A minimum amount of care and attention is necessary if the operating procedures outlined in this manual are followed closely.

This Operator's Manual should be read before operating or performing any maintenance on your equipment.

Your Taylor freezer will NOT eventually compensate and correct for any errors during the set-up or filling operations. Thus, the initial assembly and priming procedures are of extreme importance. It is strongly recommended that personnel responsible for the equipment's operation study these procedures together in order to be properly trained and to make sure that no misunderstandings exist.

In the event you should require technical assistance, please contact your local authorized Taylor Distributor.



If the crossed out wheeled bin symbol is affixed to this product, it signifies that this product is compliant with the EU Directive as well as other similar legislation in effect after August 13, 2005. Therefore, it must be collected separately after its use is completed, and cannot be disposed as unsorted municipal waste.

The user is responsible for returning the product to the appropriate collection facility, as specified by your local code.

For additional information regarding applicable local laws, please contact the municipal facility and/or local distributor.

Compressor Warranty Disclaimer

The refrigeration compressor(s) on this machine are warranted for the term indicated on the warranty card accompanying this machine. However, due to the Montreal Protocol and the U.S. Clean Air Act Amendments of 1990, many new refrigerants are being tested and developed, thus seeking their way into the service industry. Some of these new refrigerants are being advertised as drop-in replacements for numerous applications. It should be noted that, in the event of ordinary service to this machine's refrigeration system, **only the refrigerant specified on the affixed data label should be used.** The unauthorized use of alternate refrigerants will void your compressor warranty. It will be the owner's responsibility to make this fact known to any technician he employs.

It should also be noted that Taylor does not warrant the refrigerant used in its equipment. For example, if the refrigerant is lost during the course of ordinary service to this machine, Taylor has no obligation to either supply or provide its replacement either at billable or unbillable terms. Taylor does have the obligation to recommend a suitable replacement if the original refrigerant is banned, obsoleted, or no longer available during the five year warranty of the compressor.

Taylor will continue to monitor the industry and test new alternates as they are being developed. Should a new alternate prove, through our testing, that it would be accepted as a drop-in replacement, then the above disclaimer would become null and void. To find out the current status of an alternate refrigerant as it relates to your compressor warranty, call the local Taylor Distributor or the Taylor Factory. Be prepared to provide the Model/Serial Number of the unit in question.

We at Taylor are concerned about the safety of the operator when he or she comes in contact with the freezer and its parts. Taylor has gone to extreme efforts to design and manufacture built-in safety features to protect both you and the service technician. As an example, warning labels have been attached to the freezer to further point out safety precautions to the operator.



IMPORTANT - Failure to adhere to the following safety precautions may result in severe personal injury. Failure to comply with these warnings may damage the machine and its components. Component damage will result in part replacement expense and service repair expense.

To Operate Safely:



DO NOT operate the freezer without reading this operator's manual. Failure to follow this instruction may result in equipment damage, poor freezer performance, health hazards, or personal injury.



- **DO NOT** operate the freezer unless it is properly grounded.
- **DO NOT** attempt any repairs unless the main power supply to the freezer has been disconnected.
- **DO NOT** operate the freezer with larger fuses than specified on the freezer data label.

Failure to follow these instructions may result in electrocution or damage to the machine. Contact your local authorized Taylor Distributor for service.



DO NOT use a water jet to clean or rinse the freezer. Failure to follow this instruction may result in serious electrical shock.



- **DO NOT** allow untrained personnel to operate this machine.
- **DO NOT** operate the freezer unless all service panels and access doors are restrained with screws.
- **DO NOT** remove the door, beater, scraper blades, drive shaft, or torque rotor shaft unless all control switches are in the OFF position.
- **DO NOT** put objects or fingers in the door spout.

Failure to follow these instructions may result in contaminated product or severe personal injury to fingers or hands from hazardous moving parts.



USE EXTREME CAUTION when removing the beater assembly. The scraper blades are very sharp and may cause injury.



These freezers must be placed on a level surface. Failure to comply may result in personal injury or equipment damage.

DO NOT obstruct air intake and discharge openings:
Models 341/342: 3" (76 mm) minimum air space on all sides.

Model 340: 6" (152 mm) minimum air space on sides and 0" at the rear. It is recommended to install a skirt to one side of the unit, and to place the back of the unit against a wall.

Failure to follow this instruction may cause poor freezer performance and damage to the machine.

These freezers are designed to operate indoors, under normal ambient temperatures of 70°-75°F (21°-24°C). The freezers have successfully performed in high ambient temperatures of 104°F (40°C) at reduced capacities.

NOISE LEVEL: Airborne noise emission does not exceed 78 dB(A) when measured at a distance of 1.0 meter from the surface of the machine and at a height of 1.6 meters from the floor.

Section 4

Operator Parts Identification

Model 340

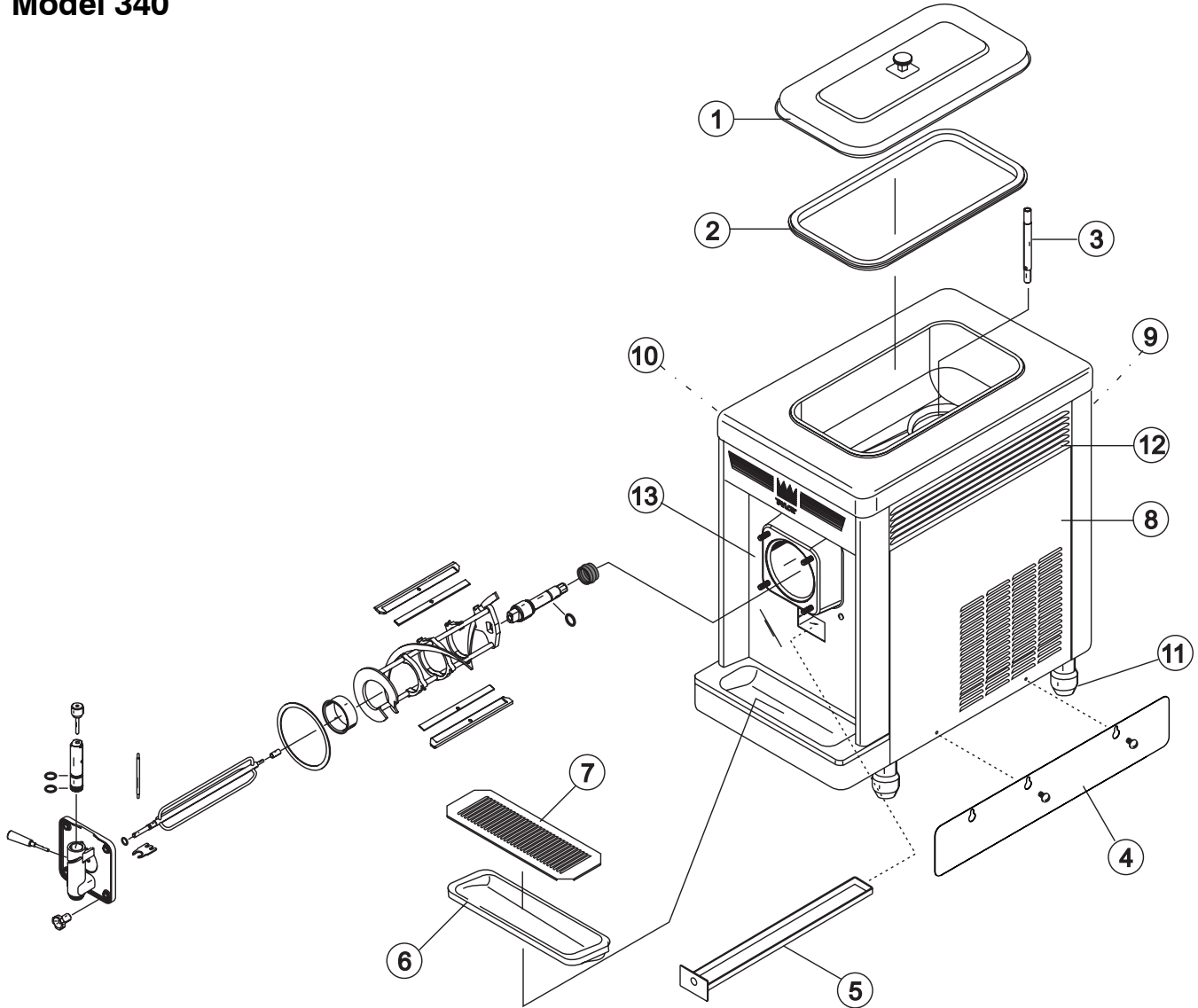

Item	Description	Part No.
1	Cover A.-Hopper	X38458
2	Gasket-Hopper Cover	038375
3	Tube-Feed	015176-9
4	Skirt-Air Flow	049069
5	Pan-Drip 19-1/2 Long	035034
6	Tray-Drip	013690
7	Shield-Splash	022763

Item	Description	Part No.
8	Panel-Right Side	047007
9	Panel-Rear	047008
10	Panel-Left Side	047006
11	Leg-4"	013458
12	Louver-Side	013631
13	Panel A.-Front	X46881

Model 341

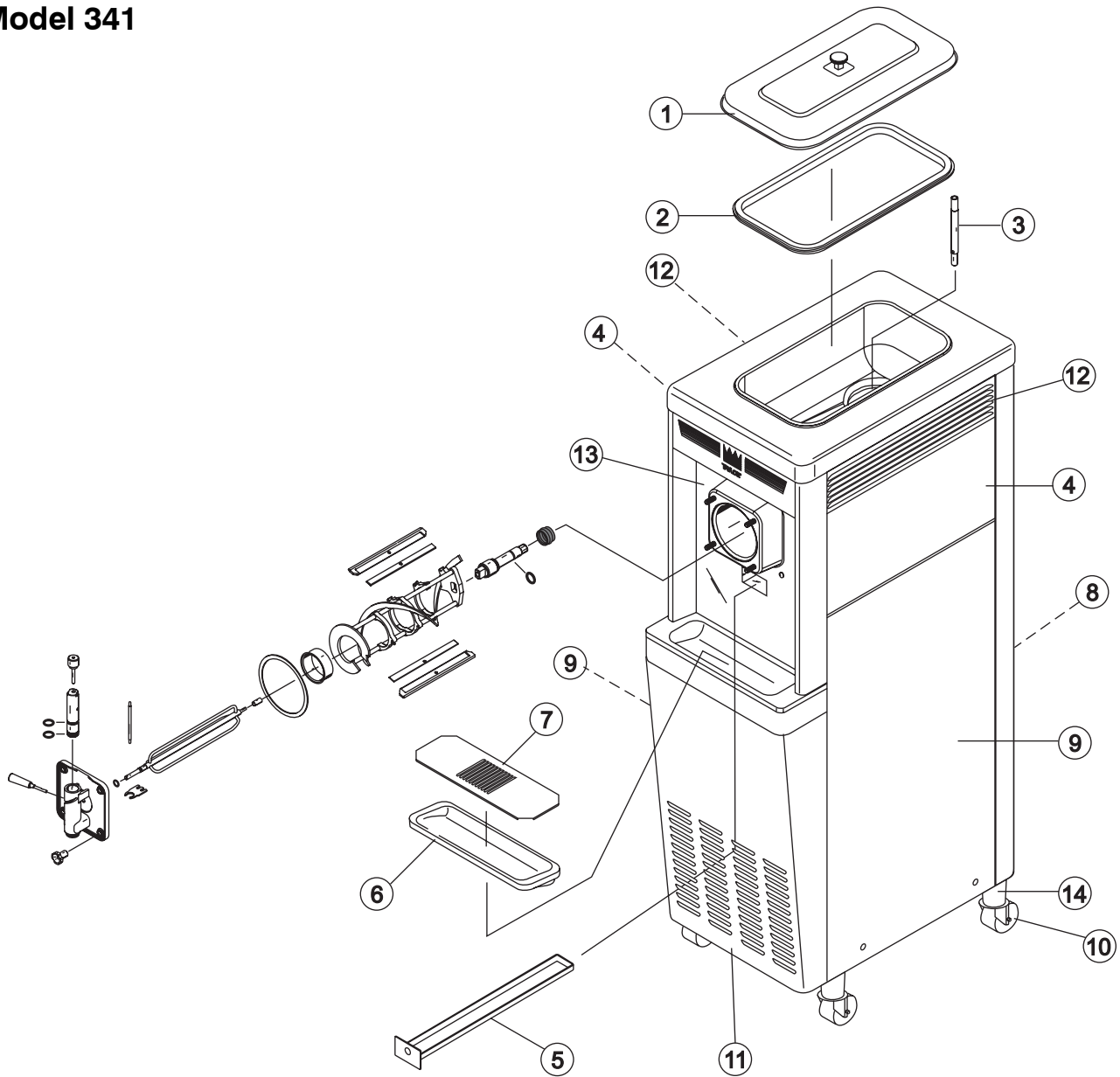

Item	Description	Part No.
1	Cover A.-Hopper	X38458
2	Gasket-Hopper Cover	038375
3	Tube-Feed	015176-9
4	Panel-Upper Side (Left/Right)	024576
5	Pan-Drip	035034
6	Tray-Drip	013690
7	Shield-Splash	022763

Item	Description	Part No.
8	Panel-Rear	013637
9	Panel A.-Lower Side (Left/Right)	X24397
10	Wheel-Caster	018794
11	Panel-Service	013638-SP1
12	Louver-Side (Left/Right)	013631
13	Panel A.-Front	X46881
14	Adapter A.-Caster	X18915

Model 342

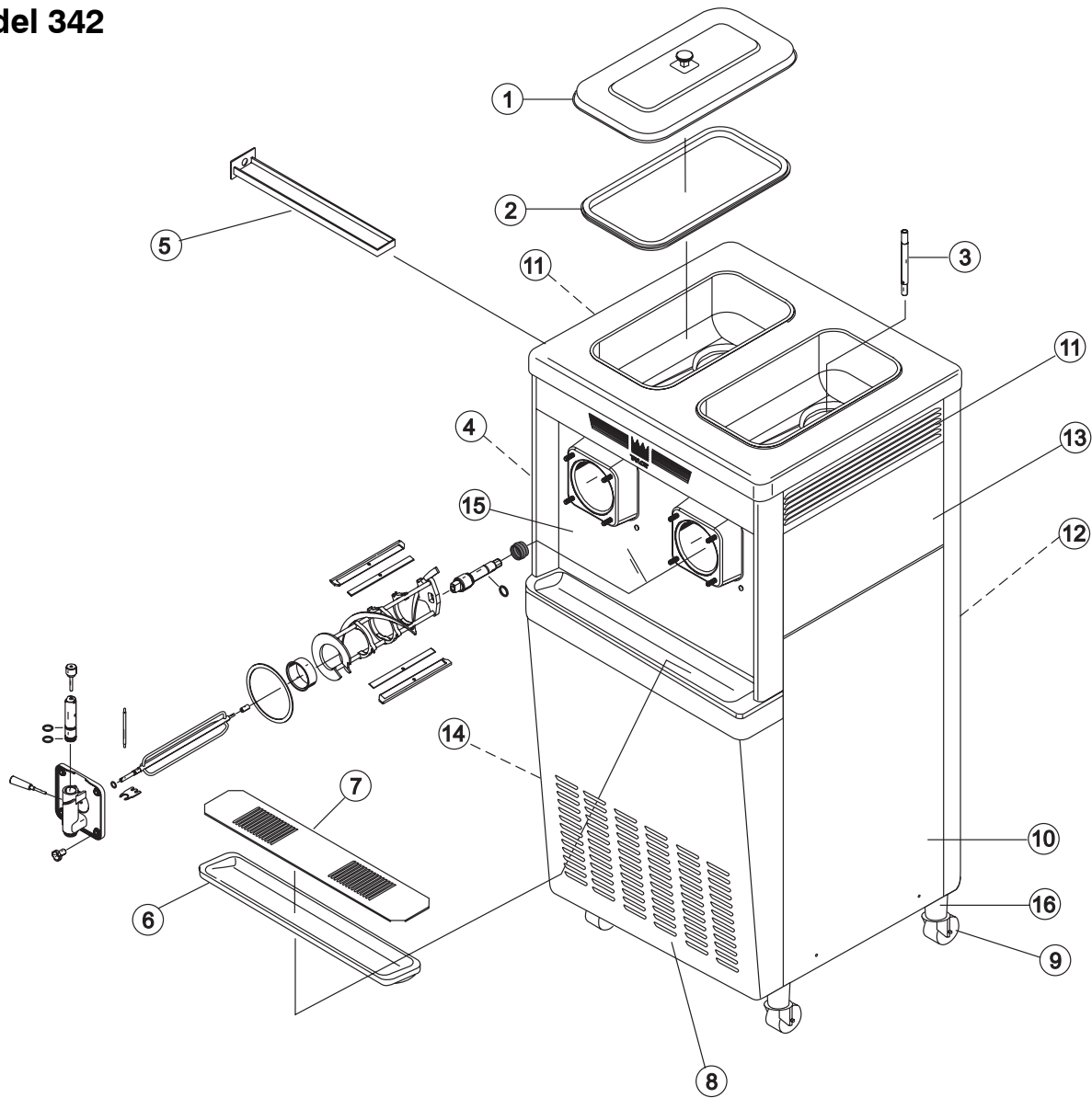

Item	Description	Part No.
1	Cover A.-Hopper	X38458
2	Gasket-Hopper Cover	038375
3	Tube-Feed	015176-9
4	Panel-Upper Left Side	028700
5	Pan-Drip	027503
6	Tray-Drip	014533
7	Shield-Splash	037041
8	Panel-Service	024439-SP1

Item	Description	Part No.
9	Wheel-Caster	018794
10	Panel A.-Lower Right Side	X44855
11	Louver-Side (Left/Right)	017471
12	Panel-Rear	017563
13	Panel-Upper Right Side	028701
14	Panel A.-Lower Left Side	X44853
15	Panel A.-Front	X25807
16	Adapter A.-Caster	X18915

Models 340, 341, 342 Beater Door Assembly

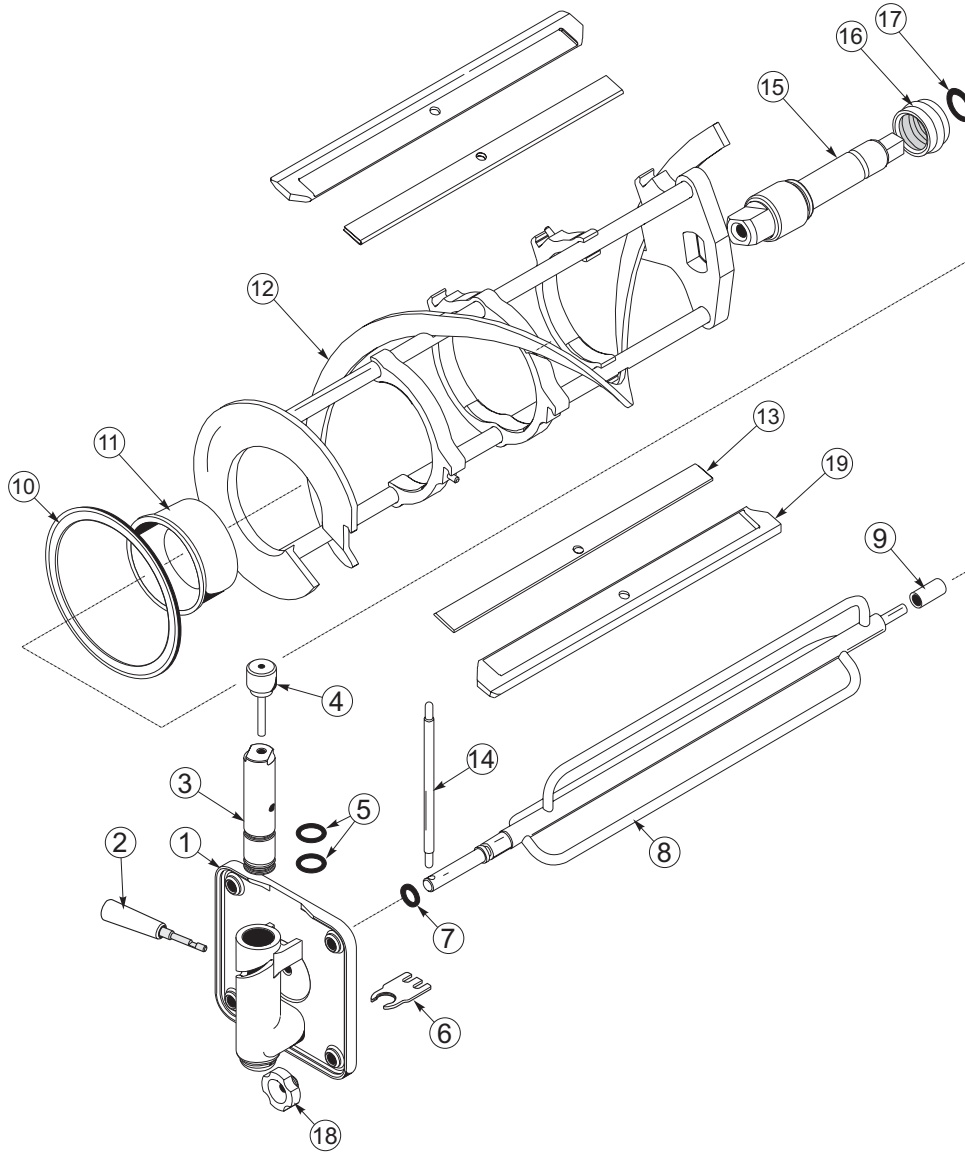

Item	Description	Part No.
1	Door A.-Partial	X39248
2	Handle A.-Draw-Slush	X25124
3	Valve-Draw	047734
4	Valve A.-Handle Pin	X25929
5	O-Ring-1 OD x .139 W	032504
6	Buster-Ice	047735
7	O-Ring-.291 ID x .080 W	018550
*8	Torque Assembly	X14488
9	Bearing-Guide	014496
10	Gasket-Door-5.109 D x 5.63 OD	014030

Item	Description	Part No.
11	Bearing-Front	013116
12	Beater A.-7 QT-1 Pin Support	X46233
13	Clip-Scraper Blade*8.75**	046238
14	Torque Arm	014500
15	Shaft-Beater	035418
16	Seal-Drive Shaft	032560
17	O-Ring-7/8 OD x .139 W	025307
18	Stud Nut	029880
19	Blade-Scraper-Plastic 9-13/16L	046237

***Note:** Use optional Torque Assembly X27027-1, Arm-Torque 029549, and Spring-Torque*Red* 020232 for soft slush application.

Accessories

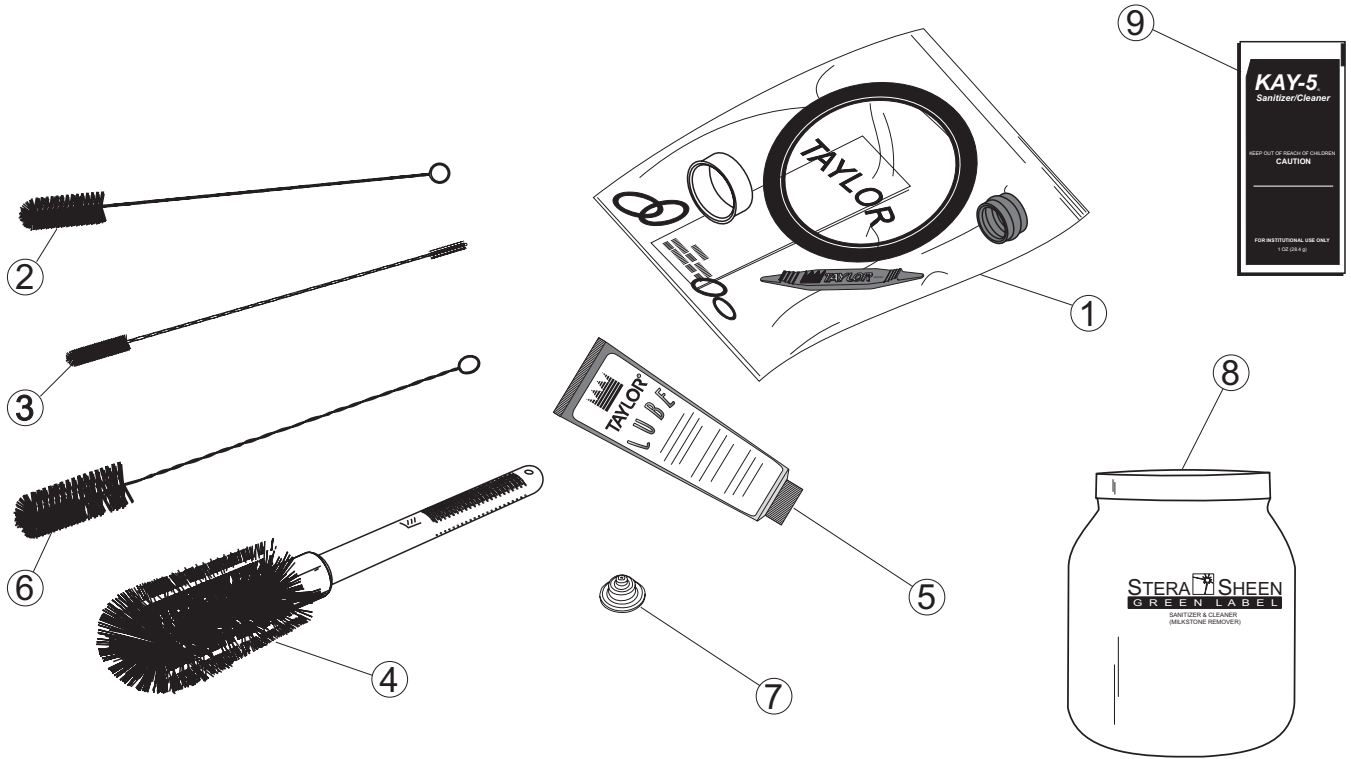

Item	Description	Part No.
1	Kit A.-Tune Up	X39969
2	Brush-Rear Bearing	013071
3	Brush-Double Ended	013072
4	Brush-Mix Pump Body	023316
5	Lubricant-Taylor Lube	047518

Item	Description	Part No.
6	Brush-Draw Valve	013073
7	Cap-Restrictor	020213
8	Sanitizer-Stera Sheen (Model 342 only)	065293
9	Sanitizer-Kay 5 (Models 340 & 341)	041082

Section 5

Important: To the Operator

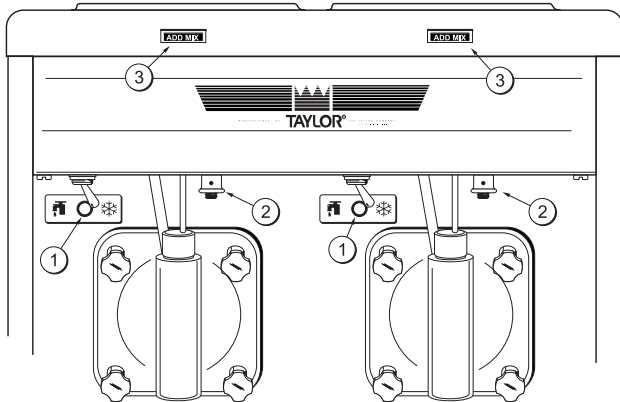





Figure 1

Item	Description
1	Control Switch
2	Consistency Control
3	Indicator Light - "Add Mix"

Symbol Definitions

To better communicate in the International arena, the words on many of our operator switches and buttons have symbols to indicate their functions. Your Taylor equipment is designed with these International symbols.

The following chart identifies the symbol definitions used on the operator switches.

-  = ON/AUTO
-  = OFF
-  = WASH

Control Switch

The center position is "OFF". The left position is "WASH", which activates only the beater motor. The right position is "AUTO", which activates the beater motor and the refrigeration system.

Consistency Control

The viscosity (thickness) of the slush is controlled by a sensing device called the consistency control. The consistency control knob is located under the control channel. To achieve a thicker slush, turn the knob **clockwise** and **counterclockwise** to achieve a thinner slush consistency.

Allow the refrigeration system to cycle on and cycle off two or three times before an accurate consistency can be evaluated.

Indicator Light - "Add Mix"

A mix level indicating light is located on the front of the machine. When the light is on, it indicates that the mix hopper has a low supply of mix and should be refilled as soon as possible. If mix is not added, a freeze-up may occur, causing eventual damage to the beater, blades, drive shaft, and freezer door.

For Your Information

The Models 340 and 341 come equipped with an optional rack assembly and four syrup jars. Each syrup jar holds 16 ounces (453.6 grams) of syrup. One pump stroke will dispense 1/4 ounce (7 grams) of syrup.

Because of the many different types of syrups on the market today, the syrup to slush ratio will vary. Consult the label or manufacturer for the proper amount of syrup for the desired drink size.

To serve slush product, simply add the flavor and open the draw valve. The slush product should blend with the syrup with no stirring necessary. If it does not, the product is too thick and the consistency control should be adjusted to a thinner consistency.

Section 6

Operating Procedures

The Model 341 has been selected to illustrate the pictured step-by-step operating procedures for the models contained in this manual. Each unit has a 20 quart (18.9 liter) mix hopper and the freezing cylinder holds 7 quarts (6.6 liters) of slush product. The Model 342 has two mix hoppers and two freezing cylinders; therefore, duplicate (where it applies) the following steps for the second side of the Model 342.

We begin our instructions at the point where we enter the store in the morning and find the parts disassembled and laid out to air dry from the previous night's brush cleaning.

These opening procedures will illustrate how to assemble these parts into the freezer, sanitize them, and prime the freezer with slush base in preparation to serve the first portion.

If you are disassembling the machine for the first time, or need information to get to this starting point in our instructions, turn to page 19, "Disassembly" and start there.

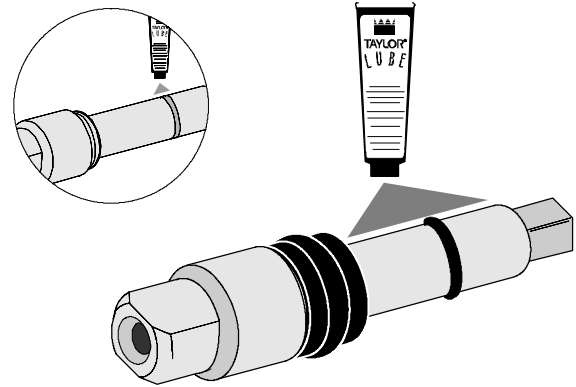

Figure 2

Insert the drive shaft into the freezing cylinder, (square end first) and into the rear shell bearing, until the seal fits securely over the rear shell bearing. Be certain the drive shaft fits into the drive coupling without binding.

Assembly



MAKE SURE CONTROL SWITCH IS IN THE "OFF" POSITION. Failure to do so may cause injury from electrocution or hazardous moving parts .

Note: When lubricating parts, use an approved food grade lubricant (example: Taylor Lube).

Step 1

Install the beater drive shaft. Slide the o-ring into the first groove on the drive shaft. Lubricate the groove, o-ring, and shaft portion that comes in contact with the bearing on the beater drive shaft. **DO NOT** lubricate the square end of the drive shaft. Slide the seal over the shaft and groove until it snaps into place. Fill the inside portion of the seal with 1/4" more lubricant and evenly lubricate the flat side of the seal that fits onto the rear shell bearing.

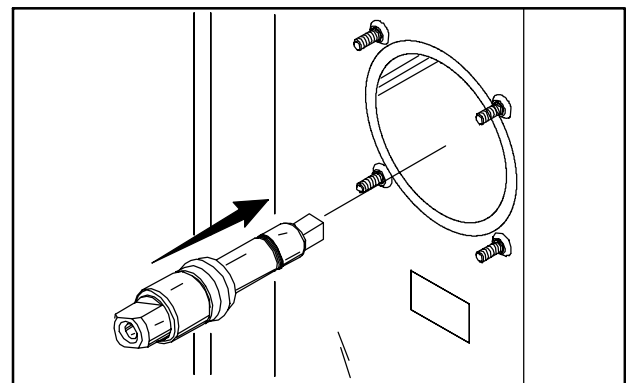

Figure 3

Step 2

Before installing the beater assembly, check the scraper blades for any nicks or signs of wear. If any nicks are present or if the blade is worn, replace both blades.

Step 3

If the blades are in good condition, install the scraper blade clip over the scraper blade. Place the rear scraper blade over the rear holding pin (knife edge to the outside). Holding the blade on the beater, turn it over and install the front blade the same way.

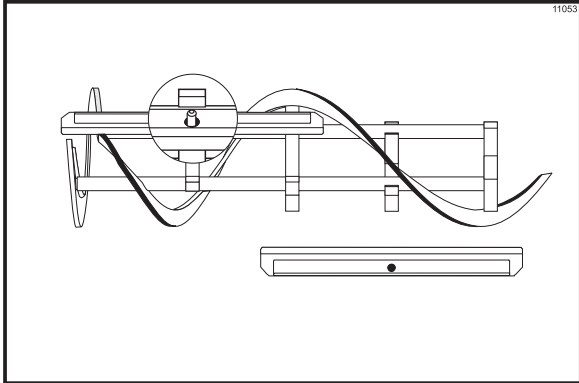

Figure 4

Holding the blade in position, insert the beater assembly into the freezing cylinder and slide it into position over the drive shaft. Turn the beater slightly to be certain that the beater is properly seated. When in position, the beater will not protrude beyond the front of the freezing cylinder.

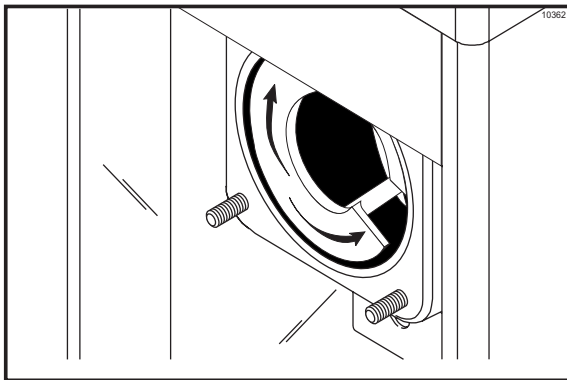

Figure 5

Step 4

Install the torque rotor shaft. Slide the o-ring into the groove on the front of the shaft and lubricate these parts to prevent leaking. Place the white, plastic guide bearing on the rear of the rotor shaft. **DO NOT** lubricate the guide bearing.

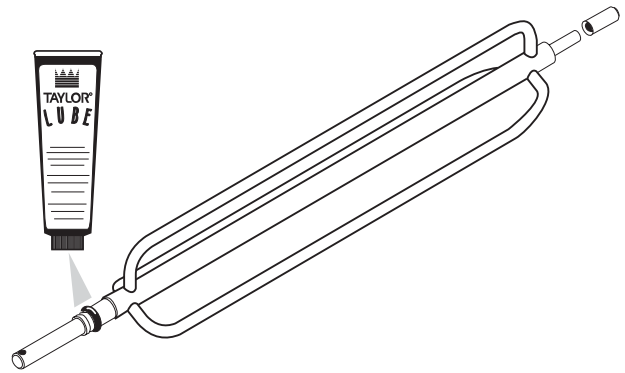

Figure 6

Insert the torque rotor shaft, plastic bearing end first, **making sure** that it fits into the hole in the beater drive shaft. Rotate it several times to check for proper positioning. The hole in the torque rotor shaft should be in the 12 o'clock position.

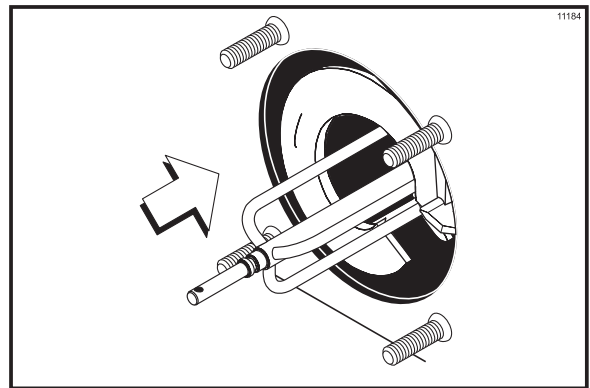

Figure 7

Step 5

Assemble the freezer door with the “Ice Buster” (door spout clearing device). To assemble the door with the ice buster, install the o-rings on the draw valve and lubricate.

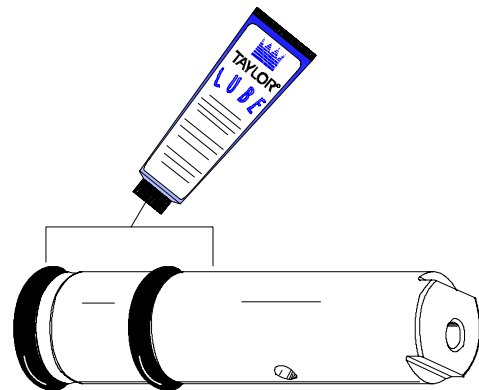

Figure 8

Insert the draw valve into the door, leaving approximately 1/2" of the valve sticking out the top of the door.

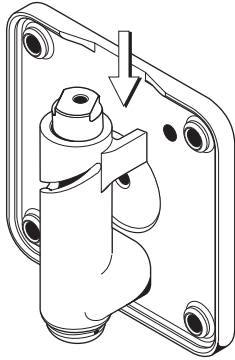

Figure 9

Rotate the draw valve so the flats on the top of the draw valve are perpendicular to the door face.

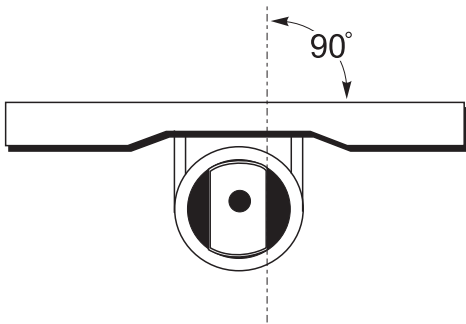

Figure 10

Insert the ice buster through the door spout and into the slot located just above the lower o-ring.

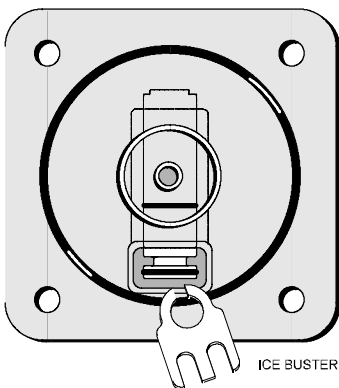

Figure 11

With the ice buster in place, rotate the draw valve to allow installation of the draw handle. This will lock the ice buster in place. Install the draw handle pin, and close the draw valve by moving the handle to the left.

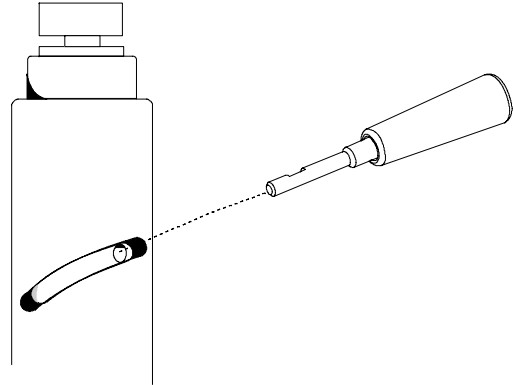

Figure 12

Place the large rubber gasket into the groove on the back side of the freezer door.

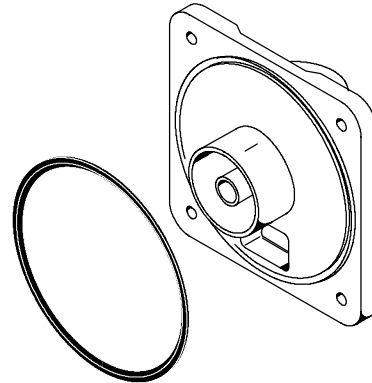

Figure 13

Slide the white, plastic front bearing onto the bearing hub, making certain that the flanged end of the bearing is resting against the freezer door. **DO NOT** lubricate the door gasket or front bearing.

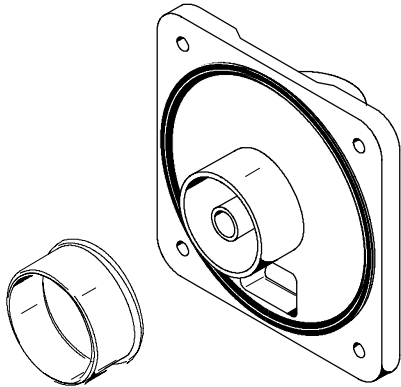

Figure 14

Step 6

Install the freezer door. Place the front end of the baffle into the hole in the center of the door. Position the door onto the four studs on the front of the freezing cylinder and push the door into place. Install the four handscrews onto the studs and tighten them equally in a crisscross pattern to insure that the door is snug. **DO NOT** over-tighten the handscrews.

Note: If the freezer door does not fit into place easily, position the open end of the beater assembly in the 11 o'clock position.

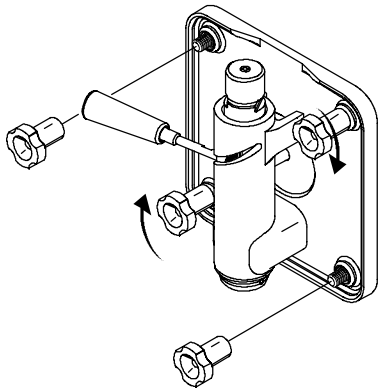

Figure 15

Step 7

Rotate the baffle assembly so the hole in the end of the shaft is vertical. Insert the torque arm between the draw valve spout supports and into the hole in the baffle assembly.

Note: During operation, the torque arm rests on the spout support.

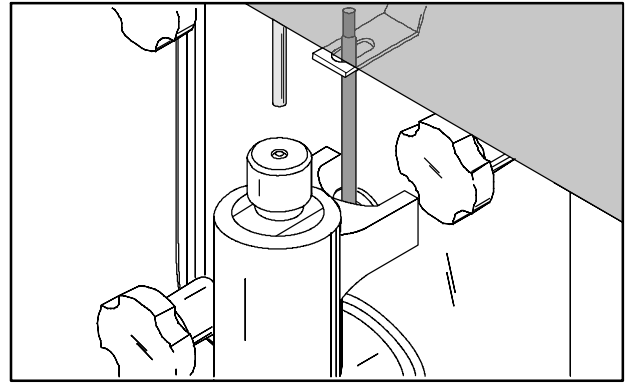

Figure 16

Step 8

Install the rear drip pan and the restrictor cap. Slide the long drip pan into the hole in the front panel.

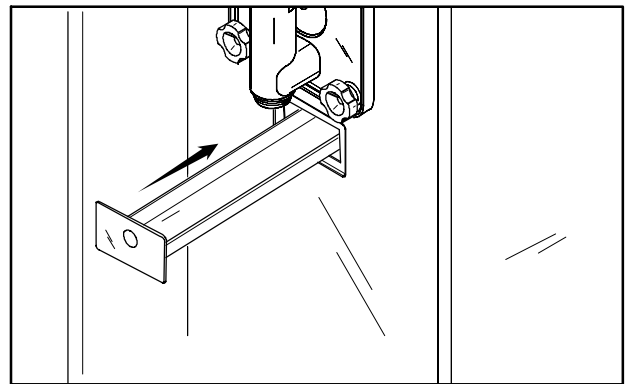

Figure 17

Step 9

Install the front drip tray and splash shield under the door spout.

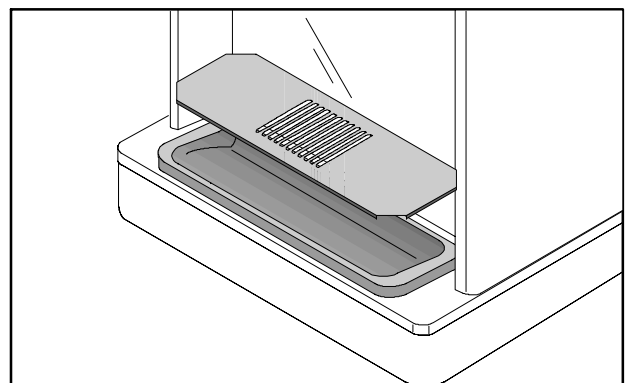

Figure 18

Step 10

Lay the hopper gasket and feed tube in the bottom of the mix hopper.

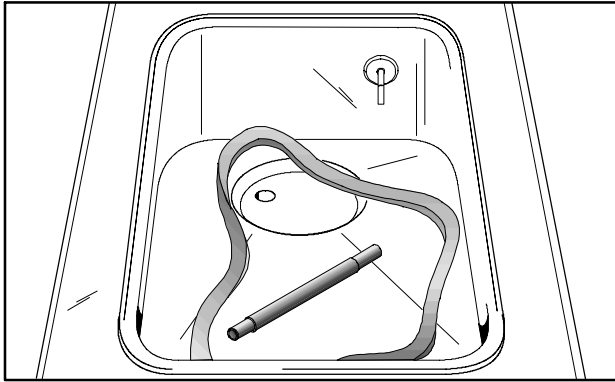

Figure 19

Step 11 (Optional Rack Assembly)

Complete the assembly by inserting the flavor bottles into the rack assembly on the front of the machine.

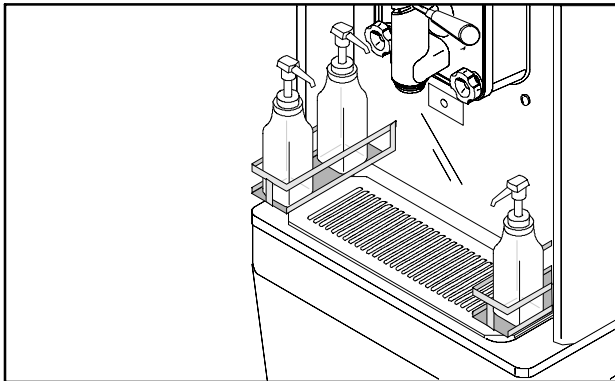

Figure 20

Sanitizing

Step 1

Prepare two gallons (7.6 liters) of an approved 100 PPM chlorine based sanitizing solution (Examples: Stera-Sheen® or Kay-5®). USE WARM WATER AND FOLLOW THE MANUFACTURER'S SPECIFICATIONS.

Step 2

Pour the two gallons (7.6 liters) of sanitizing solution into the hopper and allow it to flow into the freezing cylinder.

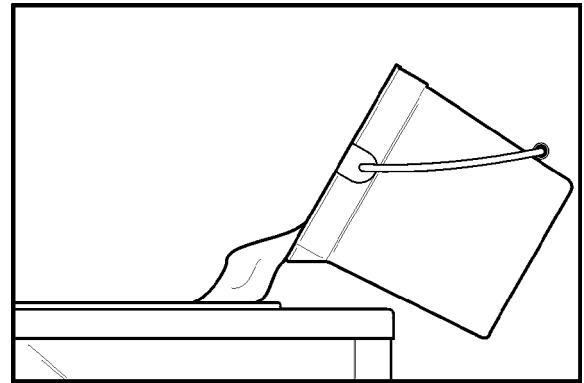

Figure 21

Step 3

While the solution is flowing into the freezing cylinder, brush clean the mix hopper, mix inlet hole, air tube and mix level sensing probe.

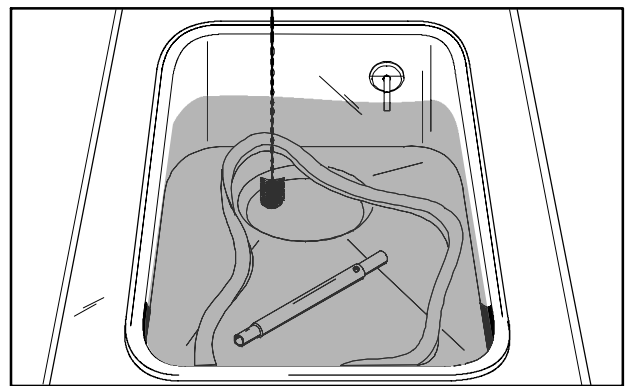

Figure 22

Step 4

Place the control switch in the "WASH" position. This will cause the sanitizing solution in the freezing cylinder to agitate. Allow the solution to agitate for five minutes.

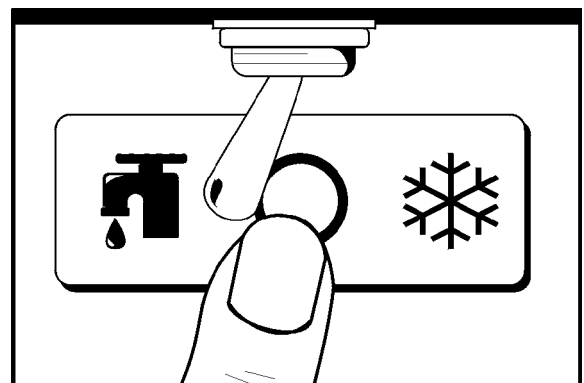

Figure 23

Step 5

Place an empty mix pail beneath the door spout and move the draw handle to the right. Draw off all the sanitizing solution. When the sanitizer stops flowing from the door spout, move the draw handle to the left and place the control switch in the "OFF" position.

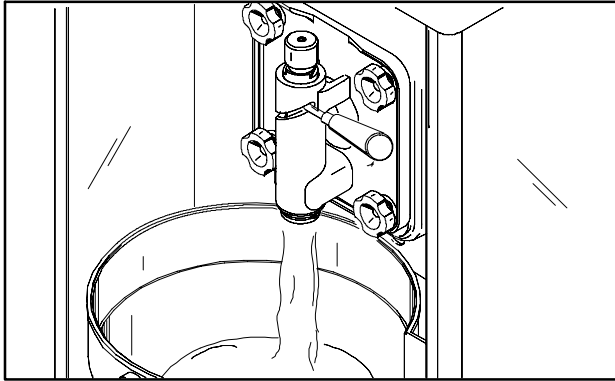

Figure 24

Step 6

With sanitized hands, assemble the hopper gasket around the top edge of the mix hopper. Stand the air tube in the corner of the hopper.

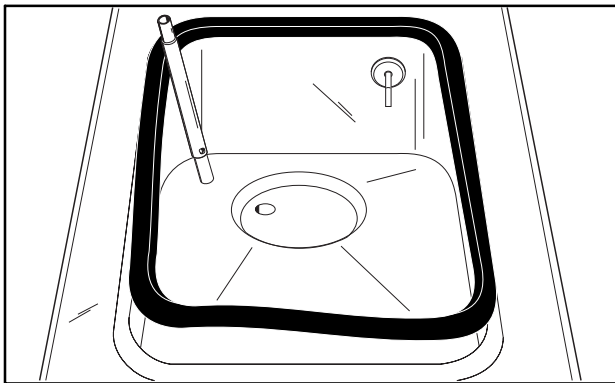

Figure 25

Priming

Step 1

With a mix pail beneath the door spout, move the draw handle to the right. Fill the hopper with FRESH slush product and allow it to flow into the freezing cylinder. This will force out any remaining sanitizing solution. When full strength mix is flowing from the door spout, move the draw handle to the left.

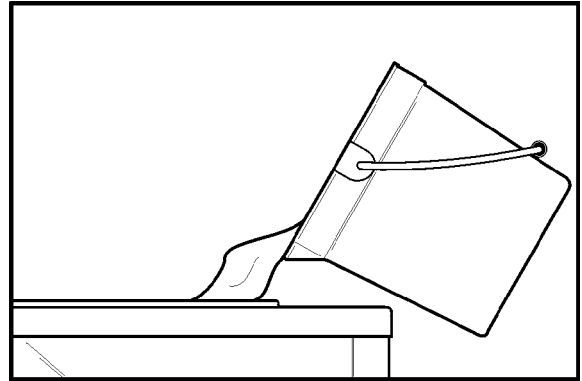

Figure 26

Step 2

When the slush product has stopped bubbling down into the freezing cylinder, install the air tube in the mix inlet hole.

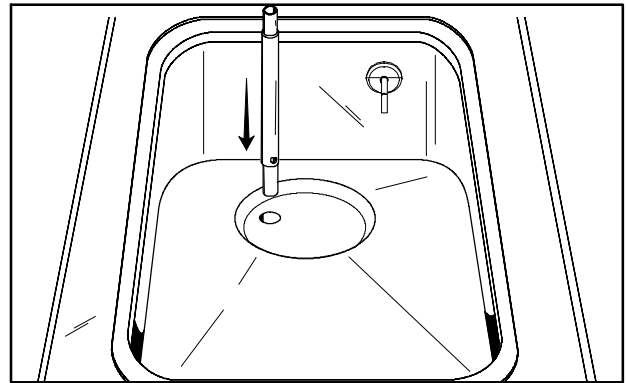

Figure 27

Step 3

Place the control switch in the "AUTO" position. When the unit cycles off, the product will be at serving viscosity.

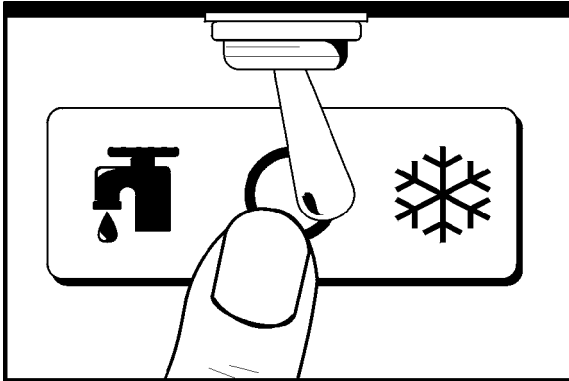

Figure 28

Step 4

Place the hopper cover into position.

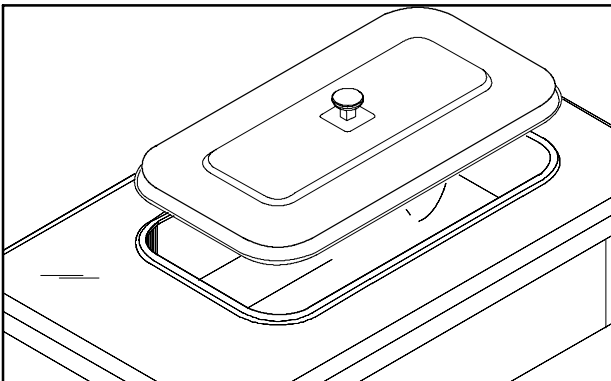

Figure 29

Step 5

(Optional Flavor Rack Assembly)

To make a refreshing slush product, add the desired flavor to the bottom of the cup by pressing the pump handle of the flavor bottle. Move the draw handle to the right and fill the cup, mixing the flavor with the product being drawn.

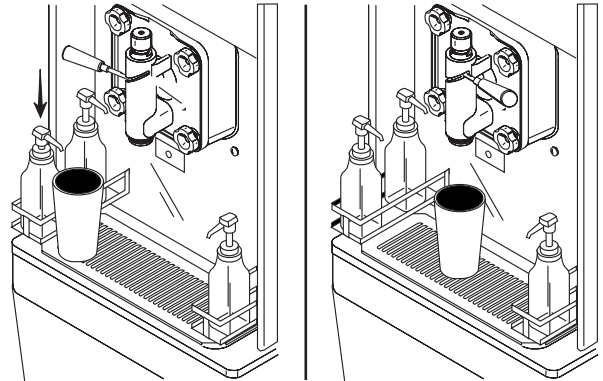

Figure 30

Closing Procedure

To disassemble the Models 340, 341, and 342, the following items will be needed:

- Two cleaning pails
- Sanitized stainless steel rerun can with lid
- Necessary brushes (provided with the freezer)
- Cleaner
- Single service towels

Draining Product From the Freezing Cylinder

Step 1

Place the control switch in the “OFF” position as far ahead of cleaning time as possible to allow frozen product to soften for easier cleaning.

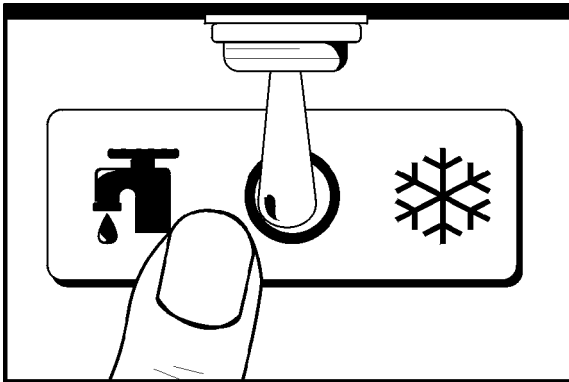

Figure 31

Step 2

Remove the hopper cover, gasket, and air tube and take these parts to the sink for cleaning.

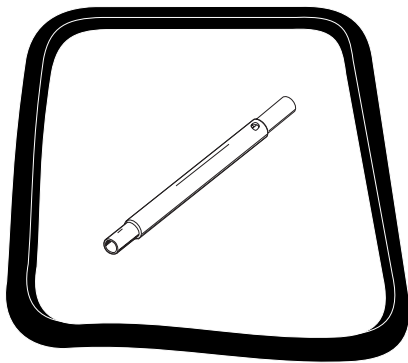

Figure 32

Step 3

With a sanitized pail under the door spout, place the control switch in the “WASH” position and move the draw handle to the right. When all the product stops flowing from the door spout, move the draw handle to the left and place the control switch in the “OFF” position. If local health codes permit, empty the rerun into the rerun can. Cover the container and place it in the walk-in cooler.

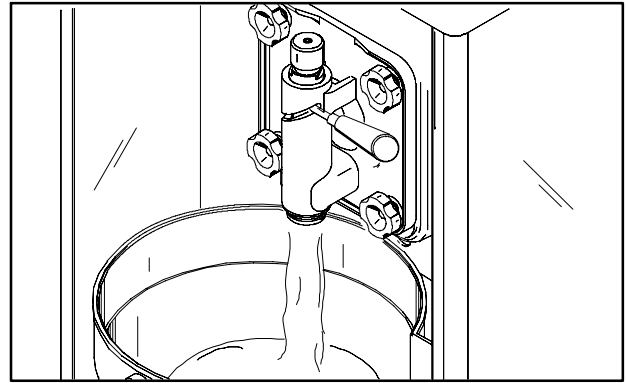

Figure 33



Rinsing

Step 1

Pour two gallons (7.6 liters) of **cool**, clean water into the mix hopper. With the brushes provided, scrub the mix hopper, mix inlet hole, and mix level sensing probe.

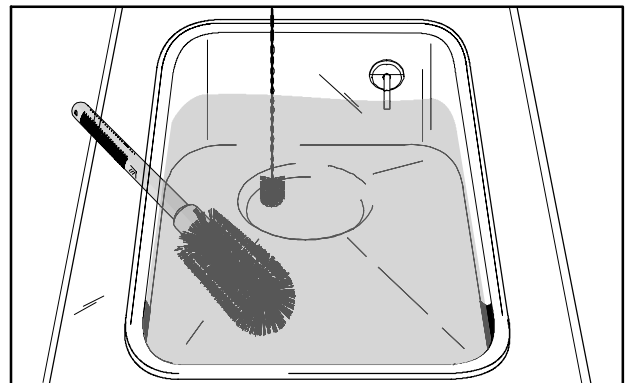

Figure 34

Step 2

With a mix pail beneath the door spout, place the control switch in the “WASH” position and move the draw handle to the right. Drain all the rinse water from the freezing cylinder. When the rinse water stops flowing from the door spout, move the draw handle to the left and place the control switch in the “OFF” position.

Repeat this procedure until the rinse water being drawn from the freezing cylinder is **clear**.

Cleaning

Step 1

Prepare two gallons (7.6 liters) of an approved cleaning solution (Examples: Stera-Sheen® or Kay-5®). USE WARM WATER AND FOLLOW THE MANUFACTURER'S SPECIFICATIONS.

Step 2

Pour the two gallons (7.6 liters) of cleaning solution into the hopper and allow it to flow into the freezing cylinder.

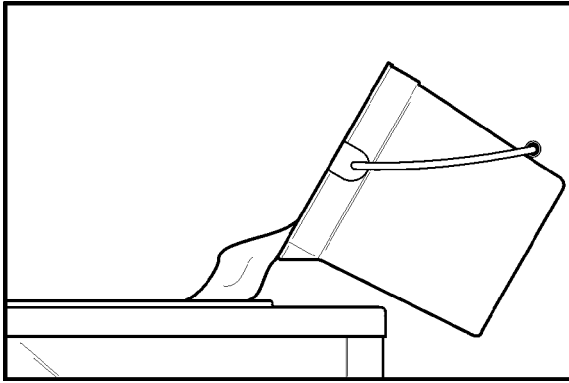

Figure 35

Step 3

While the solution is flowing into the freezing cylinder, brush clean the mix hopper and the mix inlet hole.

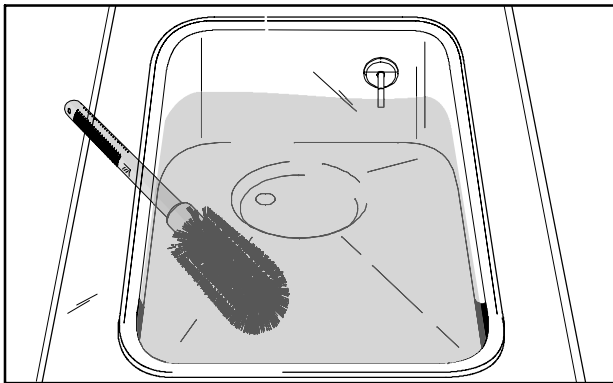

Figure 36

Step 4

Place the control switch in the "WASH" position. This will cause the cleaning solution in the freezing cylinder to agitate.

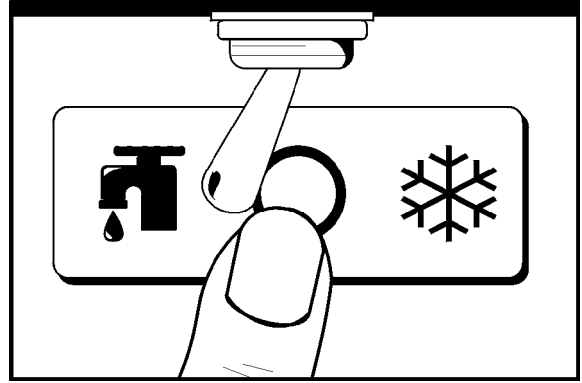

Figure 37

Step 5

Place an empty mix pail beneath the door spout and move the draw handle to the right. Draw off all of the cleaning solution. When the solution stops flowing from the door spout, move the draw handle to the left and place the control switch in the "OFF" position.

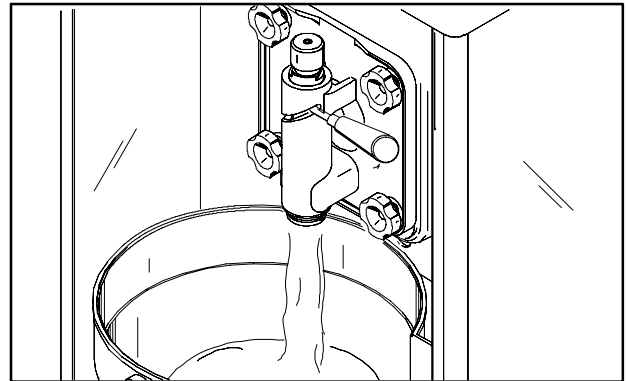

Figure 38

Disassembly



MAKE SURE CONTROL SWITCH IS IN THE “OFF” POSITION. Failure to do so may cause injury from electrocution or hazardous moving parts .

Step 1

Remove the torque arm, handscrews, freezer door, torque rotor, beater assembly, scraper blades, and the drive shaft from the freezing cylinder. Take these parts to the sink for cleaning.

Step 2

Remove the front drip tray and splash shield and take them to the sink for cleaning.

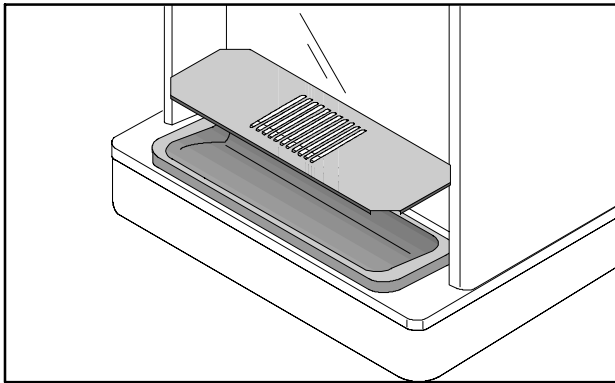

Figure 39

Brush Cleaning

Step 1

Prepare a sink with an approved cleaning solution (Examples: Stera-Sheen® or Kay-5®). **USE WARM WATER AND FOLLOW THE MANUFACTURER'S SPECIFICATIONS.**

If an approved cleaner other than Stera-Sheen® or Kay-5® is used, dilute according to label instructions. **IMPORTANT:** Follow label directions, as too **STRONG** of a solution can cause parts damage, while too **MILD** of a solution will not provide adequate cleaning. Make sure all brushes provided with the freezer are available for brush cleaning.

Step 2

Remove the o-ring and seal from the drive shaft.

Note: To remove o-rings, use a single service towel to grasp the o-ring. Apply pressure in an upward direction until the o-ring pops out of its groove. With the other

hand, push the top of the o-ring forward and it will roll out of the groove and can be easily removed.

If there is more than one o-ring to be removed, always remove the rear o-ring first. This will allow the o-ring to slide over the forward rings without falling into the open grooves.

Step 3

Remove the restrictor cap, draw valve handle, draw valve pin, draw valve, front bearing, ice buster, and gasket from the freezer door. Remove the two o-rings from the draw valve. Remove the o-ring and guide bearing from the torque rotor.

Step 4

Thoroughly brush clean all disassembled parts in the cleaning solution, making sure all lubricant and mix film is removed. Place all the cleaned parts on a clean dry surface to air dry.

Step 5

Return to the freezer with a small amount of cleaning solution. With the black bristle brush, brush clean the rear shell bearing(s) at the back of the freezing cylinder(s).

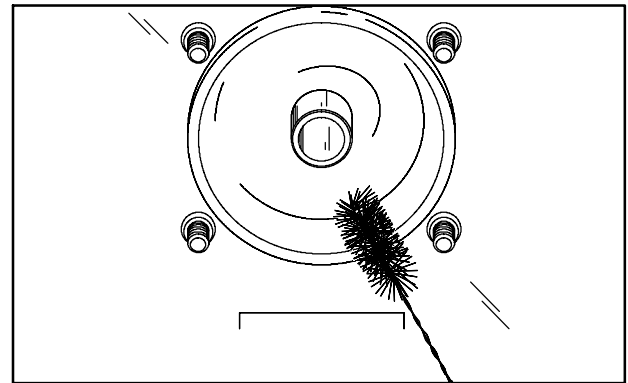

Figure 40

Step 6

Remove the rear drip pan.

Note: If the drip pan is filled with an excessive amount of mix, it is an indication that the drive shaft o-ring, seal or both should be replaced or properly lubricated.

Step 7

Wipe clean all exterior surfaces of the freezer.

Section 7 Important: Operator Checklist

During Cleaning and Sanitizing



Cleaning and sanitizing schedules are governed by your State or local regulatory agencies and must be followed accordingly. The following check points should be stressed during the cleaning and sanitizing operations.

WE RECOMMEND DAILY CLEANING AND SANITIZING.

Troubleshooting Bacterial Count

- 1. Thoroughly clean and sanitize the machine regularly, including complete disassembly and brush cleaning.
- 2. Use all brushes supplied for thorough cleaning. The brushes are specially designed to reach all mix passageways.
- 3. Use the white bristle brush to clean the mix inlet hole which extends from the mix hopper down to the rear of the freezing cylinder.
- 4. Use the black bristle brush to thoroughly clean the rear shell bearing located at the rear of the freezing cylinder. Be sure to have a generous amount of cleaning solution on the brush.
- 5. Properly prepare the cleaning and sanitizing solutions. Read and follow label directions carefully. Too strong of a solution may damage the parts and too weak of a solution will not do an adequate job of cleaning or sanitizing.
- 6. Using a screwdriver and cloth towel, keep the female square drive socket and rear shell bearing clean and free of lubricant and mix deposits.
- 7. IF LOCAL HEALTH CODES PERMIT THE USE OF RERUN, make sure the rerun is stored

in a sanitized, covered stainless steel container and used the following day.

Regular Maintenance Checks

- 1. Rotate scraper blades to allow both sides of the knife edge to wear evenly. This will contribute to self-sharpening and help maintain fast, efficient freezing.
- 2. Replace scraper blades that are nicked or damaged.
- 3. Before installing the beater, be certain that the scraper blades are properly attached over the beater pins.
- 4. Dispose of o-rings and seals if they are worn, torn, or fit too loosely, and replace them with new ones.
- 5. Follow all lubricating procedures as outlined in "Assembly".
- 6. Check the rear shell bearing for signs of wear (excessive mix leakage in rear drip pan) and be certain it is properly cleaned.
- 7. Check the condenser(s) for accumulation of dirt and lint. Dirty condensers will reduce the efficiency and capacity of the machine. Condensers should be cleaned **monthly** with a soft brush. **Never** use screwdrivers or other metal probes to clean between the fins.
Note: For machines equipped with an air filter, it will be necessary to vacuum clean the filters on a monthly schedule.
- 8. On water cooled units, check the water lines for kinks or leaks. Kinks can occur when the machine is moved back and forth for cleaning or maintenance purposes. Deteriorated or cracked water lines should be replaced only by an authorized Taylor mechanic.



Caution: Always disconnect electrical power prior to cleaning the condenser. Failure to follow this instruction may result in electrocution.

Winter Storage

If the place of business is to be closed during the winter months, it is important to protect the freezer by following certain precautions, particularly if the building is subject to freezing conditions.

Disconnect the freezer from the main power source to prevent possible electrical damage.

On water cooled freezers, disconnect the water supply. Relieve pressure on the spring in the water valve. Use air pressure on the outlet side to blow out any water remaining in the condenser, and then add a liberal amount of permanent type auto anti-freeze.

This is extremely important. Failure to follow this procedure may cause severe and costly damage to the refrigeration system.

Your local Taylor Distributor can perform this service for you.

Wrap detachable parts of the freezer such as beater, blades, drive shaft, and freezer door, and place in a protected dry place. Rubber trim parts and gaskets can be protected by wrapping them with moisture-proof paper. All parts should be thoroughly cleaned of dried mix or lubrication which attract mice and other vermin.

Section 8

Troubleshooting Guide

PROBLEM	PROBABLE CAUSE	REMEDY	PAGE REF.
1. No product is being dispensed with the draw valve opened.	a. Improper mixing of product.	a. Carefully follow the directions for mixing the product.	--
	b. There is a mix low condition.	b. Add mix to the mix hopper.	9
	c. The torque arm is not installed.	c. Install the torque arm.	
	d. The torque rotor is bent or improperly installed.	d. Replace the bent rotor or follow the assembly procedures.	11
2. The product is too thin.	a. Improper mixing of product.	a. Carefully follow the directions for mixing product.	--
	b. Scraper blades are missing or incorrectly installed.	b. Replace or install the scraper blades correctly.	10
	c. The consistency control knob needs adjusting.	c. Adjust accordingly.	9
	d. The torque rotor bound, leaving the torque arm in the "COLD" position. Therefore, the compressor will not run. (Far Right)	d. Free the torque rotor.	--
3. The product is too stiff.	a. The torque rotor bound, leaving the torque arm in the "WARM" position. Therefore, the compressor continually runs. (Far Left)	a. Free the torque rotor.	--
	b. The torque arm is bent or is missing.	b. Install or replace the torque arm.	13
	c. The consistency control knob needs adjusting.	c. Adjust accordingly.	9
	d. Improper mixing of product.	d. Carefully follow the directions for mixing product.	--
	e. There is insufficient product in the freezing cylinder.	e. Keep the hopper full of mix.	9

PROBLEM	PROBABLE CAUSE	REMEDY	PAGE REF.
4. The walls of the freezing cylinder are scored.	a. Broken beater pins.	a. Repair or replace the beater assembly.	--
	b. The gear unit is out of alignment.	b. Contact service technician.	--
	c. The beater assembly is bent.	c. Repair or replace the beater assembly.	--
	d. The front bearing is missing.	d. Replace or install the front bearing.	13
5. Unable to remove the drive shaft.	a. There is lubrication on the square end of the drive shaft.	a. Do not lubricate the square end. Contact service technician for removal.	10
	b. The corners of the drive shaft and/or drive coupling are bent.	b. Replace the drive shaft and/or drive coupling.	--
6. There is excessive mix leakage in the rear drip pan.	a. There is improper or inadequate lubrication on the drive shaft o-ring or seal.	a. Use an approved food grade lubricant (example: Taylor Lube) and follow the lubrication procedures.	10
	b. Bad or missing o-ring or seal on drive shaft.	b. Replace every 3 months.	10 / 25
	c. The rear shell bearing is worn.	c. Contact service technician for replacement.	--
7. There is no freezer operation with the unit in the "AUTO" position.	a. The unit is unplugged.	a. Plug cord in wall receptacle.	--
	b. The beater motor has tripped.	b. Place the power switch in the "OFF" position. Allow the motor to cool and then resume normal operation. Contact service technician if the problem continues.	--
	c. The circuit breaker is tripped or the fuse is blown.	c. Reset the circuit breaker or replace the blown fuse.	--
8. The unit is not freezing product when in the "AUTO" position.	a. The torque rotor bound, leaving the torque arm in the "COLD" position. Therefore, the compressor will not run. (Far Right)	a. Free the torque rotor.	--
	b. The torque arm is bent.	b. Replace the torque arm.	13
	c. The condensers are dirty.	c. Clean the condensers regularly.	20

PROBLEM	PROBABLE CAUSE	REMEDY	PAGE REF.
9. The guide bearing is missing.	a. The guide bearing is stuck in the drive shaft.	a. Remove the guide bearing from the hole in the drive shaft.	- -
10. There is excessive leakage from the door spout.	a. There is improper or inadequate lubrication on the draw valve o-rings.	a. Use an approved food grade lubricant (example: Taylor Lube) and follow the lubrication procedures.	11
	b. The draw valve o-ring is bad or missing.	b. Replace o-rings every three months.	25
11. The door will not go into position easily.	a. The beater assembly is incorrectly positioned.	a. The open end of the beater assembly should be in the 11 o'clock position.	13

Section 9

Parts Replacement Schedule

PART DESCRIPTION	EVERY 3 MONTHS	EVERY 6 MONTHS	ANNUALLY	QTY.
Drive Shaft O-Ring	X			1*
Drive Shaft Seal	X			1*
Scraper Blade	Inspect & Replace if Necessary	Minimum		2*
Torque Rotor O-Ring	X			1*
Guide Bearing	X			1*
Freezer Door Gasket	X			1*
Front Bearing	X			1*
Draw Valve O-Ring	X			2*
Black Bristle Brush, 1" x 2"		Inspect & Replace if Necessary	Minimum	1
Double Ended Brush		Inspect & Replace if Necessary	Minimum	1
White Bristle Brush, 1" x 2"		Inspect & Replace if Necessary	Minimum	1
White Bristle Brush, 3" x 7"		Inspect & Replace if Necessary	Minimum	1

*Double quantity for the Model 342.

Refer to the Parts List on page 26 when ordering the above parts.

Section 10

Parts List

DESCRIPTION	PART NUMBER	340 QTY.	341 QTY.	342 QTY.	WARR. CLASS	REMARKS	PARTS UPDATE
ADAPTOR A.-CASTER	X18915		4	4	103		
ARM A.-ANTICIPATOR MECHANICAL	X29556	1	1	2	103		
ARM-TORQUE	014500	1	1	2	103		
BEARING-FRONT	013116	1	1	2	000		
BEARING-GUIDE	014496	1	1	2	000	TORQUE ASSEMBLY	
BEARING-REAR SHELL *PLASTIC*	032511	1	1	2	000		
+ GUIDE-DRIP SEAL	028992	1	1	2	000		
+ NUT-BRASS BEARING	028991	1	1	2	000		
+ O-RING-1-1/16 OD X .070 WALL	018432	1	1	2	000		
+ WASHER-BEARING LOCK	012864	1	1	2	000		
BEATER A.-7QT-1 PIN-SUPPORT	X46233	1	1	2	103		
+ BLADE-SCRAPER-PLASTIC 9-13/16L	046237	2	2	4	000		
CLIP-SCRAPER BLADE	046238	2	2	4	000		
BELT-V-4L460	013859	1			000		
BELT-V-4L400	007590		1		000		
BELT-V-4L430	009613			2	000		
BLOCK-TERMINAL 2P	039422	1	1	2	103	208/230-60-1	
BLOCK-TERMINAL 2 POLE 115V	039421	1	1	2	103	115-60-1	
BLOWER A.	X47833-		1	1	103		
BOOT-CAPACITOR INSULATING	031314		1	1	000		
CAPACITOR-RUN- 15UF/370V	049356		1	1	103	115-60-1	
CAPACITOR-RUN- 10 UF/370V	033047		1	1	103	208/230-60-1	
HOUSING A.-WHEEL	X30160		1	1	103		
MOTOR-BLOWER FAN 120V 60HZ	049355-12		1	1	103	115-60-1	
MOTOR-BLOWER-208/230V 50/60	046536-27		1	1	103	208/230-60-1	
BRUSH-DOUBLE ENDED-PUMP&FEED T	013072	1	1	1	000		
BRUSH-DRAW VALVE 1"ODX2"X17"L	013073	1	1	1	000		
BRUSH-MIX PUMP BODY-3"X7"WHITE	023316	1	1	1	000		
BRUSH-REAR BRG 1IN.DX2IN.LGX14	013071	1	1	1	000		
CAP-RESTRICTOR	020213	1	1	2	000		
CASTER-SWV 5/8 STEM 4IN W	018794		4	4	103		
COMPRESSOR L61B562BBCB	048727-	1	1	2	512		
+ CAPACITOR-RUN- 20UF/370V	023606	1	1	2	103	208/230-60-1	
+ CAPACITOR-START-161-193UF/250V	031790	1	1	2	103	208/230-60-1	

+ Available Separately

020729

DESCRIPTION	PART NUMBER	340 QTY.	341 QTY.	342 QTY.	WARR. CLASS	REMARKS	PARTS UPDATE
+ RELAY-START-COMPRESSOR	048765	1	1	2	103	208/230-60-1	
+ CAPACITOR-RUN- 20UF/370V	023606		1	2	103	115-60-1	
+ CAPACITOR-START-189-227UF/330V	033044		1	2	103	115-60-1	
+ RELAY-START-COMPRESSOR	049656		1	2	103	115-60-1	
+ COMPRESSOR AJ7455Z	050301-12	1			512	115-60-1	
+ CAPACITOR-RUN- 15UF/370V	027087	1			103	115-60-1	
+ CAPACITOR-START-340-408UF/165V	047608	1			103	115-60-1	
+ RELAY-START-COMPRESSOR	047609	1			103	115-60-1	
CONDENSER-AC-15LX14HX2.59T-3RW	046558	1			103		
CONDENSER-AC-12LX18HX2.6T	048233		1	2	103		
CONTROL-MIX LEVEL	031799-	1	1	2	103		
COVER A.-HOPPER-STD	X38458	1	1	2	103		
+ GASKET-HOPPER COVER-20 QT-SGL	038375	1	1	2	000		
KNOB-MIX COVER	025429	1	1	2	103		
DECAL-CLEAN INST.-HOPPER	019029	1	1	1	000		
DECAL-DEC-TAYLOR	021872	1	1	1	000		
DECAL-TROUBLESHOOTING	038374	1	1	1	000		
DECAL-WARNING *PANEL*	036529	3	3	3	000		
DECAL-WASH-OFF-AUTO	014502	1	1	2	000		
DEFLECTOR-BLOWER EXHAUST	048345		1		103		
DIAGRAM-WIRING *340-341-342*	049359	1	1	2	000		
DOOR A.-PARTIAL *340-350-450*	X39248	1	1	2	103		
+ BUSTER-ICE	047735	1	1	2	103		
+ GASKET-DOOR 5.109"ID X 5.630OD	014030	1	1	2	000		
+ HANDLE A.-DRAW-SLUSH-BLUE	X25124	1	1	2	103		
+ O-RING-1"OD X .139W	032504	2	2	4	000		
+ VALVE A.-HANDLE PIN	X25929	1	1	2	103		
+ VALVE-DRAW *SLUSH* ICE BUSTER	047734	1	1	2	103		
DRYER-FILTER-HP62-3/8 X 1/4S	048901	1	1	2	000		
GEAR A.*REDUCER	015985	1	1	2	212		
GUARD-BELT	023845			1	103		
GUIDE A.-DRIP PAN	X47190	1	1		103		
GUIDE A.-DRIP PAN	X28698			2	103		
HOOD *310-311 320-321	021222	1			103		
HOOD *410-40-41-710-41	023285		1		103		

+ Available Separately

DESCRIPTION	PART NUMBER	340 QTY.	341 QTY.	342 QTY.	WARR. CLASS	REMARKS	PARTS UPDATE
HOOD	023263			1	103		
HUB-5/8 BORE SPLIT	027815	1	1	2	103	GEAR PULLEY	
KIT A.-TUNE UP*SLUSH*	X39969	1	1	2	000		
BEARING-FRONT	013116	1	1	2	000		
BEARING-GUIDE	014496	1	1	2	000		
GASKET-DOOR 5.109"ID X 5.630OD	014030	1	1	2	000		
O-RING-.291 ID X .080W	018550	1	1	2	000		
O-RING-1"OD X .139W	032504	2	2	4	000		
O-RING-7/8 OD X .139W	025307	1	1	2	000		
SEAL-DRIVE SHAFT	032560	1	1	2	000		
TOOL-CLEANING O-RING REMOVAL	048260	1	1	2	000		
KNOB-ADJUSTMENT	014499	1	1	2	103		
+ SCREW-ADJUSTMENT	014498	1	1	2	103		
LABEL-DOOR CAUTION	032749	1	1	1	000		
LABEL-MOVING PARTS WARNING	024315	3	3	3	000		
LEG-4" SS-W/ORING	013458	4			103		
LIGHT-INDICATOR-RED-RECT.	023056-	1	1	2	103		
LOUVER-SIDE	013631	1	2		103	340 UPPER LEFT SIDE	
LOUVER-SIDE	017471			2	103		
LUBRICANT-TAYLOR 4 OZ.	047518	1	1	1	000		
MAN-OPER 340/341/342	028764-M	1	1	1	000		
MOTOR-1/4 HP	014477-	1	1	2	212		
MOTOR-FAN 120 W 208/230V 60HZ	041401-	1			103		
+ BRACKET-FAN *453*750*	038641	1			103		
+ CAPACITOR-RUN- 4UF-370V	019624	1			103	208/230-60-1	
+ CAPACITOR-RUN- 7.5UF/370V	034749	1			103	115-60-1	
+ FAN-5 BLADE 12" PUSH 32DEG CCW	047279	1			103		
NUT-STUD *340-342-344-350-450*	029880	4	4	8	103	HANDSCREWS	
PAIL-6 QT.	023348	1			000		
PAIL-MIX 10 QT.	013163		1	1	000		
PAN-DRIP 19-1/2 LONG	035034	1	1		103		
PAN-DRIP 11-5/8 LONG	027503			2	103		
PANEL A.-FRONT	X46881	1	1		103		
PANEL A.-FRONT	X25807			1	103		
PANEL A.-SIDE	X44853			1	103		

+ Available Separately

DESCRIPTION	PART NUMBER	340 QTY.	341 QTY.	342 QTY.	WARR. CLASS	REMARKS	PARTS UPDATE
PANEL A.-SIDE	X44855			1	103		
PANEL A.-SIDE LOWER	X24397		2		103		
PANEL-REAR	013637		1		103		
PANEL-REAR *390*340*490*	047008		1		103		
PANEL-REAR	017563			1	103		
PANEL-SERVICE *341*	013638-SP1		1		103		
PANEL-SERVICE *342*	024439-SP1			1	103		
PANEL-SIDE *390*340*490*LEFT	047006	1			103		
PANEL-SIDE *390*340*490*RIGHT	047007	1			103		
PANEL-SIDE *5472 HT* UPPER	042317	1			103	UPPER RIGHT SIDE	
PANEL-UPPER SIDE *410-15*	024576		2		103		
PANEL-UPPER SIDE LEFT	028700			1	103		
PANEL-UPPER SIDE RIGHT	028701			1	103		
PLATE-DEC-340-341	043456	1	1		103		
PLATE-DEC-TWIN	022602-BLK			1	103		
PLUG-DRIP TRAY HOLE	029595		1		000		
PROBE A.-MIX *SQUARE*	X30922	1	1	2	103		
+ DISC-PROBE *SQ HOLE*	030965	1	1	2	103		
+ SPACER-PROBE *SQ HOLE*	030966	1	1	2	103		
PULLEY-AK23-1/2	013997	1	1	2	103	BEATER MOTOR	
PULLEY-AK69H	010840	1	1	2	103	GEAR	
RELAY-3 POLE-20A-208/240 50/60	012725-	1	1	2	103		
SANITIZER KAY-5 125 PACKETS	041082	1	1		000		
SANITIZER-STERA SHEEN-GREEN	065293			1	000		
SHAFT-BEATER *341-2 RFB*	035418	1	1	2	103		
+ O-RING-7/8 OD X .139W	025307	1	1		000		
+ SEAL-DRIVE SHAFT	032560	1	1	2	000		
SHELL A.-INSULATED *340*	X39936-SP1	1	1	2	512		
+ STUD-NOSE CONE-5/16-18X5/16-18	013496	4	4	8	103		
SHIELD-SPLASH 15"L X 5-13/32"W	022763	1	1		103		
SHIELD-SPLASH	037041			1	103		
SHROUD-FAN *453*	039023	1			103		
SKIRT-AIR FLOW *062*340*AC	049069	1			103		
+ COLLAR-HOLDING	019481	2			103		
+ SCREW-10-32X3/4 OVAL HD-SS	001086	2			000		

+ Available Separately

DESCRIPTION	PART NUMBER	340 QTY.	341 QTY.	342 QTY.	WARR. CLASS	REMARKS	PARTS UPDATE
SPRING- EXTENSION.375X.025X2.25	029310	1	1	2	103		
SPRING- TORQUE*BLUE*	029259	1	1	2	103		
SPRING- TORQUE*GREEN*	014497	1	1	2	103	HARD SLUSH	
SWITCH A. - TORQUE *340- 341- 342*	X29601	1	1	2	103		
BUSHING- 1/2OD X 3/8ID- PLASTIC	014474	2	2	4	000		
HUB A.- ARM	X29602	1	1	2	103		
HUB- PIVOT	014475	1	1	2	103		
SWITCH- LEVER- SPDT- 20A- 125- 480V	027026	1	1	2	103		
SWITCH- PRESSURE 440 PSI- SOLDER	048230	1	1	2	103		
SWITCH- TOGGLE- DPDT*ON- OFF- ON	014464	1	1	2	103		
TIMER- DELAY ON MAKE- 10 MIN	029312-	1	1	2	103		
TORQUE A. *340- 1- 2- 3- 50- 1- 450*	X14488	1	1	2	103	X27027- 1 TORQUE & 029549 ARM- TORQUE*SOFT	OPTIONAL
+ O- RING- .291 ID X .080W	018550	1	1	2	000		
TRAY- DRIP 14- 7/8L X 5- 1/8 SGL	013690	1	1		103		
TRAY- DRIP 22- 7/8L X 5- 1/8W	014533			1	103		
TRIM- CORNER *390*LEFT	047002	1			103		
TRIM- CORNER *390*RIGHT	047003	1			103		
TRIM- FRONT *390*	047001	1			103		
TRIM- REAR CORNER	013620		2		103		
TRIM- REAR CORNER	013663			1	103		
TRIM- REAR CORNER	013761			1	103		
TUBE- FEED- 3/8 HOLE	015176- 9	1	1	2	103		
VALVE- ACCESS 1/4FL X 3/8S	043232		1	2	103		
VALVE- ACCESS 1/4FL X 3/8SDR- 90	044455	1			103	LOW SIDE	
VALVE- ACCESS- 1/4 MFLX1/4 S- 90	047016	1	1	2	103	DISCHARGE LINE	
VALVE- EXP- AUTO- 1/4S X1/4 FPT	046365	1	1	2	103		
+ BOOT- EXPANSION VALVE	027137	1	1	2	000		
VALVE- SOLENOID- MECHANICAL	030202-	1	1	2	103		

+ Available Separately

040823

DESCRIPTION	PART NUMBER	340 QTY.	341 QTY.	342 QTY.	WARR. CLASS	REMARKS	PARTS UPDATE
WATER COOLED							
ACCUMULATOR-COPPER 2"DIA 10"LG	047062	1	1	2	103		
BLOWER-100 CFM	012796-		1	1	103		
BRACKET-MOUNTING-WATER VALVE	038777	1	1		103		
CONDENSER-WC-COAX	048287		1	2	103		
CONDENSER-WC-SPIRAL 11-1/2 OD	049309	1			103		
GUARD-BLOWER	022505			2	103		
HOSE-RUBBER 1/2 ID X 7/8 OD	R50200	4 ft.	4 ft.	8 ft.	000		
MOTOR-FAN 9 WATT 1550RPM-CW	012768-	1			103		
+ FAN-5 BLADE 7 " PUSH 30DJE CW	016289	1			103		
OUTLET A.-TEE	X25900			1	103		
PANEL A.-SIDE LOWER	X24397			2	103		
SWITCH-PRESSURE 350 PSI-SOLDER	048231	1	1	2	103		
TEE-3/8" PIPE WATER VALVE	032953			1	103		
VALVE-WATER 3/8 REG/HEAD PRESS	046686	1	1	2	103		
50Hz							
BELT-V-4L470	007994	1			000		
BELT-V-4L410	007530		1		000		
BELT-V-4L440	009387			2	000		
BLOCK-TERMINAL-7 POLE GREEN	024156			2	103		
COMPRESSOR L61B562BKB	048727-40	1	1	2	512	208/230-50-1	
+ CAPACITOR-RUN- 15UF/370V	027087	1	1	2	103	208/230-50-1	
+ CAPACITOR-START-161-193UF/250V	031790	1	1	2	103	208/230-50-1	
+ RELAY-START-COMPRESSOR	048766	1	1	2	103	208/230-50-1	
DIAGRAM-WIRING *340-341-342*	049359-40	1	1	2	000		
MOTOR-FAN 100W 220-240V 50HZ	047178-34	1	1		103	208/230-50-1	
PULLEY-AK27- 1/2	016190	1	1	2	103	BEATER MOTOR	
SOFT SLUSH							
ARM-TORQUE *340/341/342*	029549		1	1	103		
TORQUE A. *342 SOFT SLUSH	X27027-1		1	1	103		
SPRING-TORQUE*RED*	020232		1	1	103		

+ Available Separately

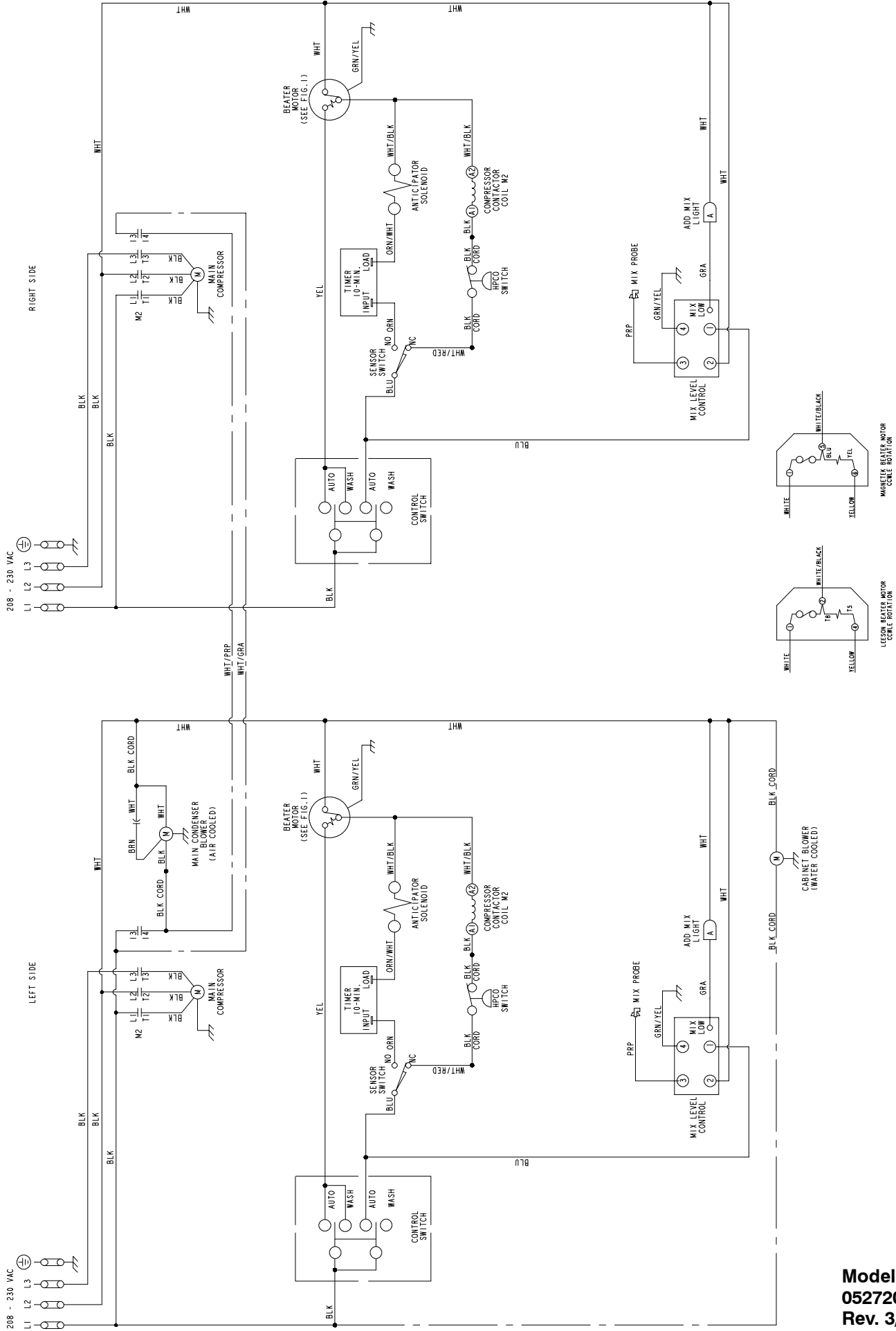

FIG. 1

Model 342
052720-33
Rev. 3/06

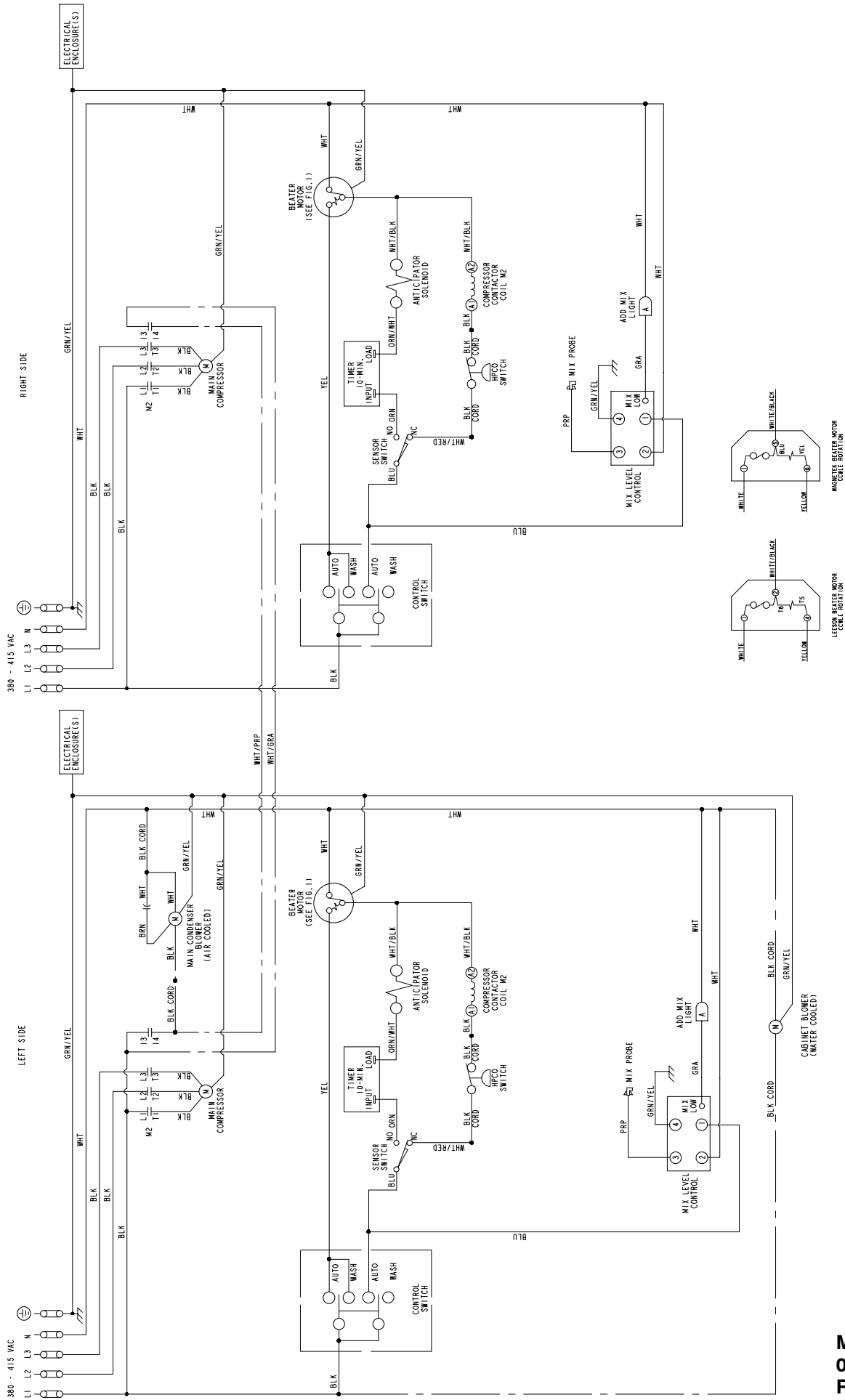

FIG. 1