

Models 150, 152, 162, & 168

Taylormate Soft Serve Freezers

Operating Instructions

028749-M



Complete this page for quick reference when service is required:

Taylor Distributor: _____

Address: _____

Phone: _____

Service: _____

Parts: _____

Date of Installation: _____

Information found on data plate:

Model Number: _____

Serial Number: _____

Electrical Specs: Voltage _____ Cycle _____

Phase _____

Maximum Fuse Size: _____ Amps

Minimum Wire Ampacity: _____ Amps

Part Number: _____

© June, 1998 Taylor
All rights reserved.
028749-M



*The word Taylor and the Crown design
are registered trademarks in the United States
of America and certain other countries.*

Taylor Company
a division of Carrier Commercial Refrigeration, Inc.
750 N. Blackhawk Blvd.
Rockton, IL 61072

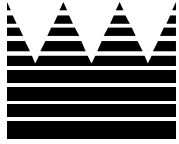

Table of Contents

Section 1	To the Installer	1
	Air Cooled Units	1
	Electrical Hook-Up Installation for 60 Cycle, 1 Phase, Supplied With Cord and Plug	1
	Electrical Connections for Models Without Cord and Plug Supplied	1
Section 2	To the Operator	2
	Compressor Warranty Disclaimer	2
Section 3	Safety	3
Section 4	Operator Parts Identification	4
	Model 150	4
	Model 152	5
	Model 162	6
	Model 168	7
	Models 150 & 152 Door Assembly	8
	Models 162 & 168 Door Assembly	9
Section 5	Important: To the Operator	10
	Push-Button Switch	10
	Power Switch	10
	Temperature Control	10
	Air Tube	11
	Taylor Quality Control	11
	Indicator Light - "Mix Low"	11
	Mix Refrigeration Switch	11
	Separate Hopper Refrigeration (SHR)	12
	Cylinder Temperature Retention (CTR)	12
	Syrup Rail	12
Section 6	Operating Procedures	13
	Assembly	14
	Sanitizing	17
	Priming	19
	Closing Procedure	20
	Draining Product From the Freezing Cylinder	20
	Rinsing	20
	Cleaning	20
	Disassembly	21
	Brush Cleaning	21

Section 7	Important: Operator Checklist	22
	During Cleaning and Sanitizing	22
	Troubleshooting Bacterial Count	22
	Regular Maintenance Checks	22
	Winter Storage	23
Section 8	Troubleshooting Guide	24
Section 9	Parts Replacement Schedule	27
Section 10	Parts List	28
	Wiring Diagrams	37

Note: Continuing research results in steady improvements; therefore, information in this manual is subject to change without notice.

Section 1

To the Installer

Air Cooled Units

The models 150 and 152 require a minimum of 6" (152 mm) of clearance around both sides. Install the skirt provided on the right side of the unit and place the back of the unit against a wall to prevent recirculation of warm air. The model 162 requires 6" (152 mm) on all sides and the skirt installed on the rear of the unit. The model 168 requires 3" (76 mm) on all sides and the skirt installed on the rear of the unit. Minimum air clearances must be met to assure adequate air flow for optimum performance.

These machines are designed for indoor use only.



DO NOT install the machines in an area where a water jet could be used. Failure to follow this instruction may result in serious electrical shock.

Electrical Hook-Up Installation For 60 Cycle, 1 Phase, Supplied With Cord and Plug

This equipment is supplied with a 3-wire cord and grounding type plug for connection to a single phase, 60 cycle, branch circuit supply. This unit must be plugged into a properly grounded receptacle. The cord and plug provided for 115/60/1, is 20 amp; therefore the wall outlet must also be 20 amp. Check the data label, located on the side panel, for electrical specifications.

Permanent wiring may be employed if required by local codes. Instructions for conversion to permanent wiring are as follows:

1. Be sure the freezer is electrically disconnected.
2. Remove the appropriate panel and locate the small electrical box at the base of the freezer.
3. Remove the factory-installed cord and strain relief bushing.
4. Route incoming permanent wiring through 7/8" (22 mm) hole in base pan.
5. Connect two power supply leads. Attach ground (earth) wire to the grounding lug inside the electrical box.
6. Be sure the unit is properly grounded before applying power.



FOLLOW YOUR LOCAL ELECTRICAL CODES!

Electrical Connections For

Models Without Cord and Plug Supplied

Each freezer requires one power supply for each data label. Check the data label(s) on the freezer for fuse, circuit ampacity and electrical specifications. Refer to the wiring diagram provided inside of the control box, for proper power connections.

In the United States, this equipment is intended to be installed in accordance with the National Electrical Code (NEC), ANSI/NFPA 70-1987. The purpose of the NEC code is the practical safeguarding of persons and property from hazards arising from the use of electricity. This code contains provisions considered necessary for safety. Compliance therewith and proper maintenance will result in an installation essentially free from hazard! In all other areas of the world, equipment should be installed in accordance with the existing local codes. Please contact your local authorities.

Stationary appliances which are not equipped with a power cord and a plug or other device to disconnect the appliance from the power source must have an all-pole disconnecting device with a contact gap of at least 3 mm installed in the external installation.



CAUTION: This equipment must be properly grounded! Failure to do so can result in severe personal injury from electrical shock!

Beater rotation must be clockwise as viewed looking into the freezing cylinder.

Note: The following procedures should be performed by an authorized service technician.

To correct rotation on a three-phase unit, interchange any two incoming power supply lines at freezer main terminal block only. To correct rotation on a single-phase unit, change the leads inside the beater motor. (Follow diagram printed on motor.)

Electrical connections are made directly to the terminal block provided in the splice box, mounted on the base pan on each side of the model 168, and located in the splice boxes mounted mid-level on the frame channel on the sides of the model 162.

Section 2

To the Operator

The freezer you have purchased has been covered by a 3-year warranty.

We at Taylor Company are concerned about the safety of the operator when he or she comes in contact with the freezer and its parts. Taylor has gone to extreme efforts to design and manufacture built-in safety features to protect both you and the service technician. As an example, warning labels have been attached to the freezer to further point out safety precautions to the operator.



IMPORTANT! Failure to adhere to the following safety precautions may result in severe personal injury. Failure to comply with these warnings may damage the machine and its components. Component damage will result in part replacement expense and service repair expense.

To Operate Safely:



DO NOT operate the freezer without reading this operator's manual. Failure to follow this instruction may result in equipment damage, poor freezer performance, health hazards, or personal injury.



- **DO NOT** operate the freezer unless it is properly grounded.
- **DO NOT** operate the freezer with larger fuses than specified on the freezer data label.
- **DO NOT** attempt any repairs unless the main power supply to the freezer has been disconnected.

Failure to follow these instructions may result in electrocution. Contact your local authorized Taylor Distributor for service.



DO NOT use a water jet to clean or rinse the freezer. Failure to follow these instructions may result in serious electrical shock.



- **DO NOT** allow untrained personnel to operate this machine.
- **DO NOT** put objects or fingers in door spout.
- **DO NOT** operate the freezer unless all service panels and access doors are restrained with screws.
- **DO NOT** remove the freezer door or beater assembly unless the control switches are in the "OFF" position.

Failure to follow these instructions may result in severe personal injury from hazardous moving parts.



Section 4

Operator Parts Identification

Model 150

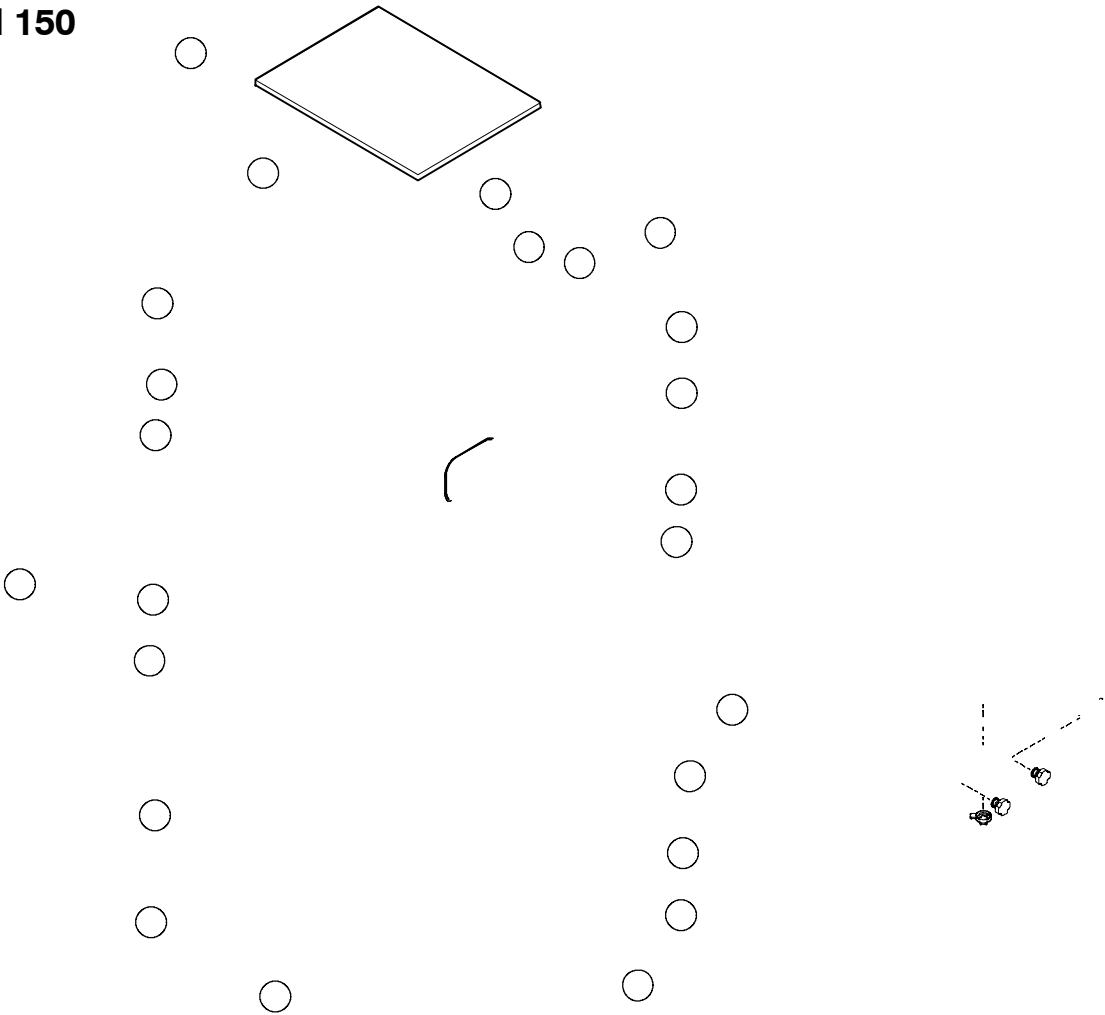

Model 152

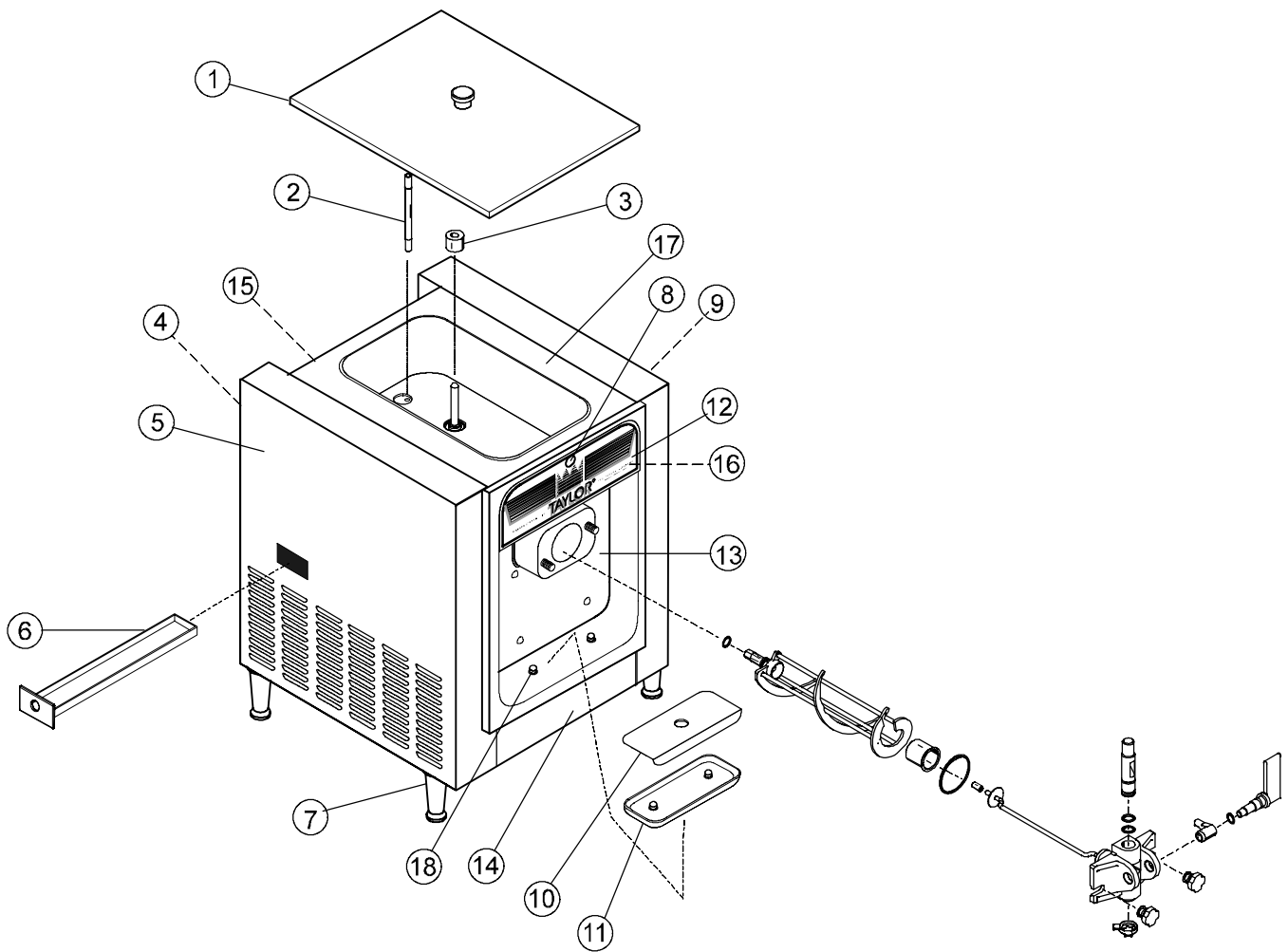

Item	Description	Part No.
1	Hopper Cover Assembly	X48690
2	Feed Tube	025061
3	Float A.-Mix Level	X39690
4	Back Panel	025868-SS
5	Left Side Panel	028591-SS
6	Drip Pan	027503
7	Leg-Plastic	024755
8	Mix Low Light	039708
9	Right Side Panel	025867-SS

Item	Description	Part No.
10	Splash Shield	025063
11	Drip Tray	025062
12	Decorative Decal	047667
13	Panel A.-Front	X25036
14	Trim-Front	025862-SS
15	Trim-Top Back	025866
16	Plate-Decorative	041034-SS
17	Hood Assembly	X49065
18	Holder-Drip Tray	035866

Model 162

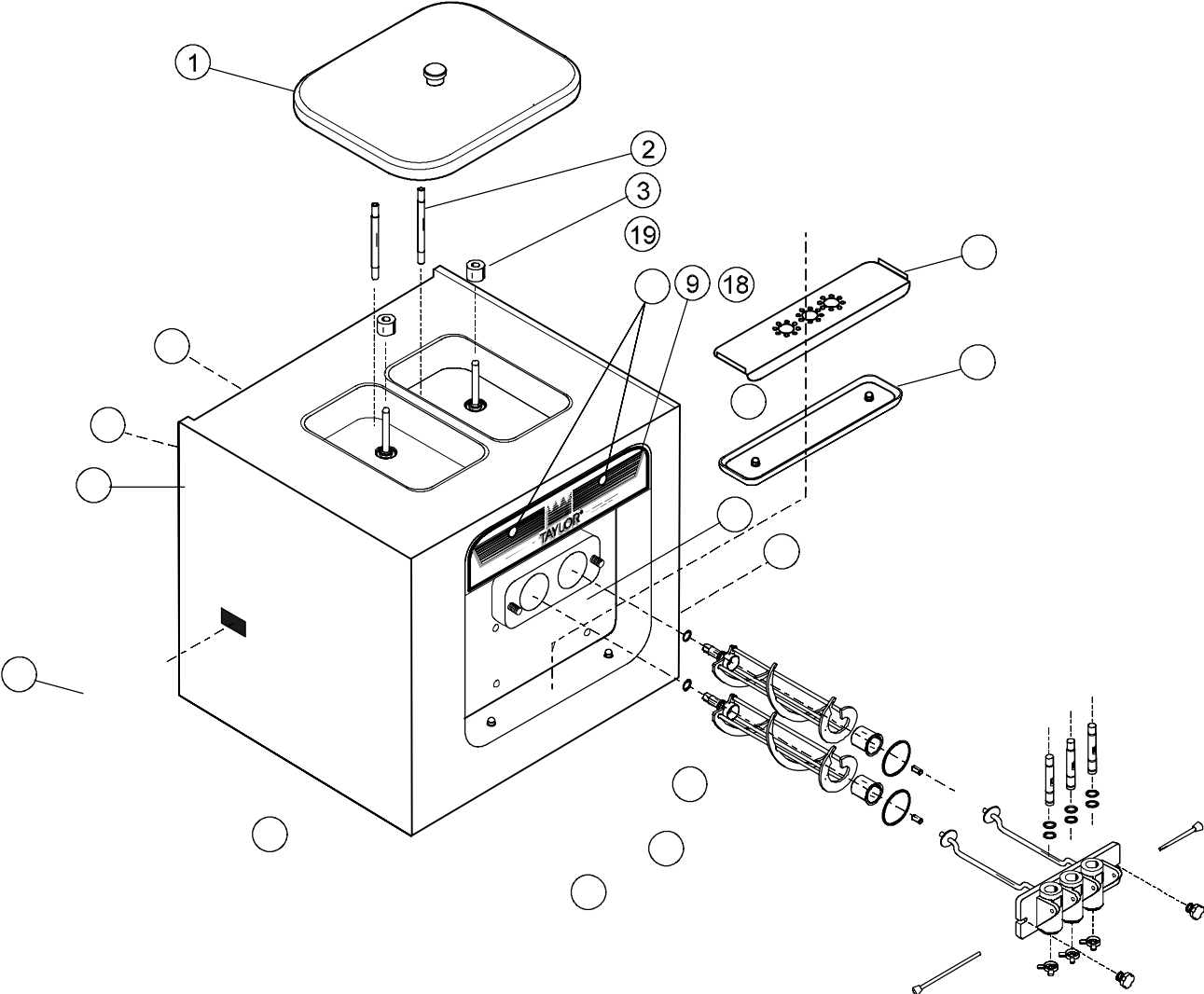

Model 168

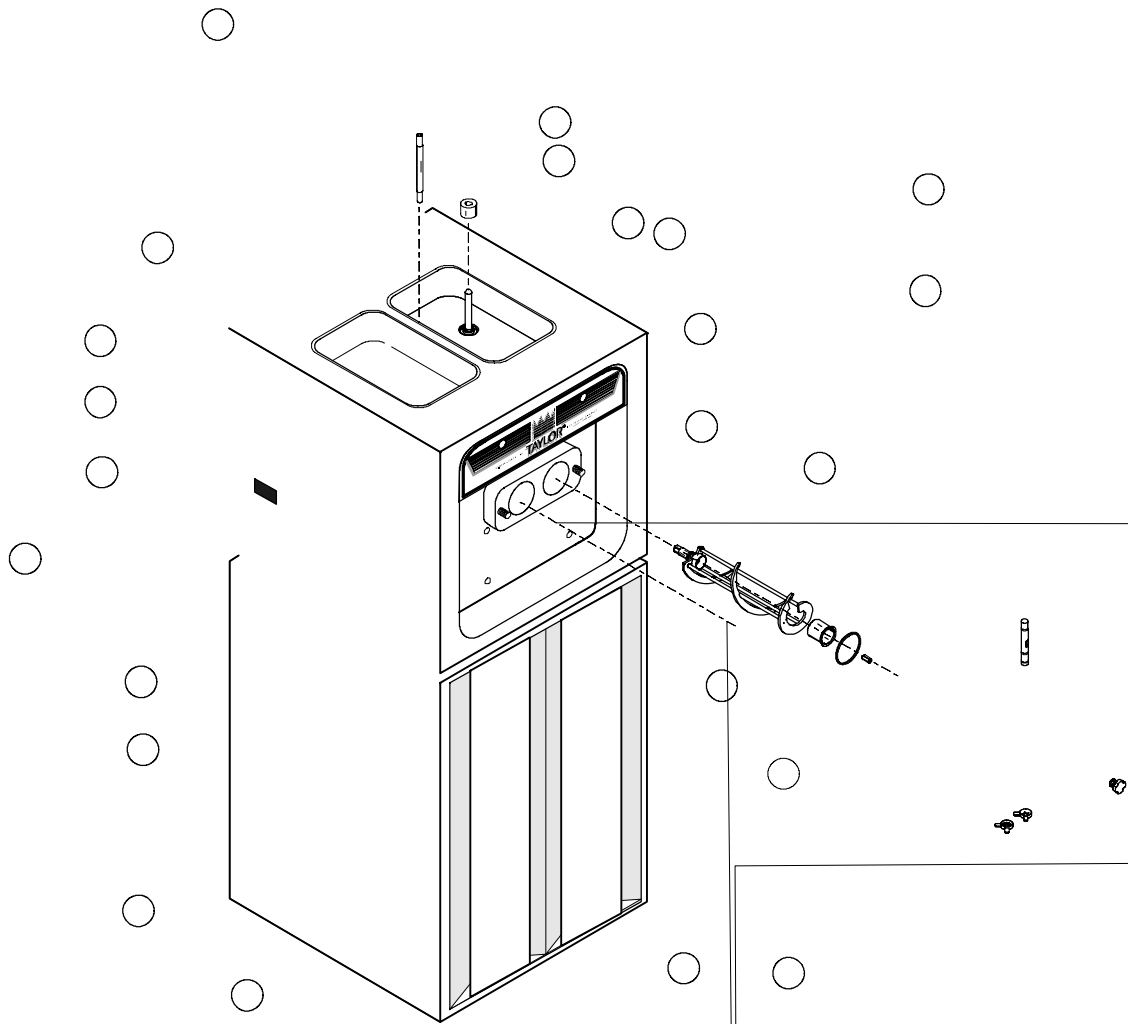

Models 150 & 152 Door Assembly

Models 162 & 168 Door Assembly

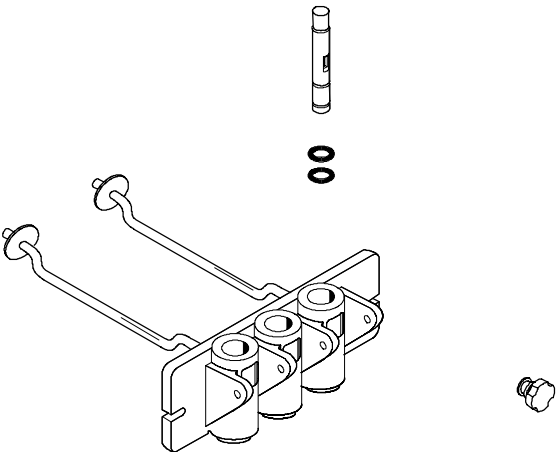

Section 5

Important: To the Operator

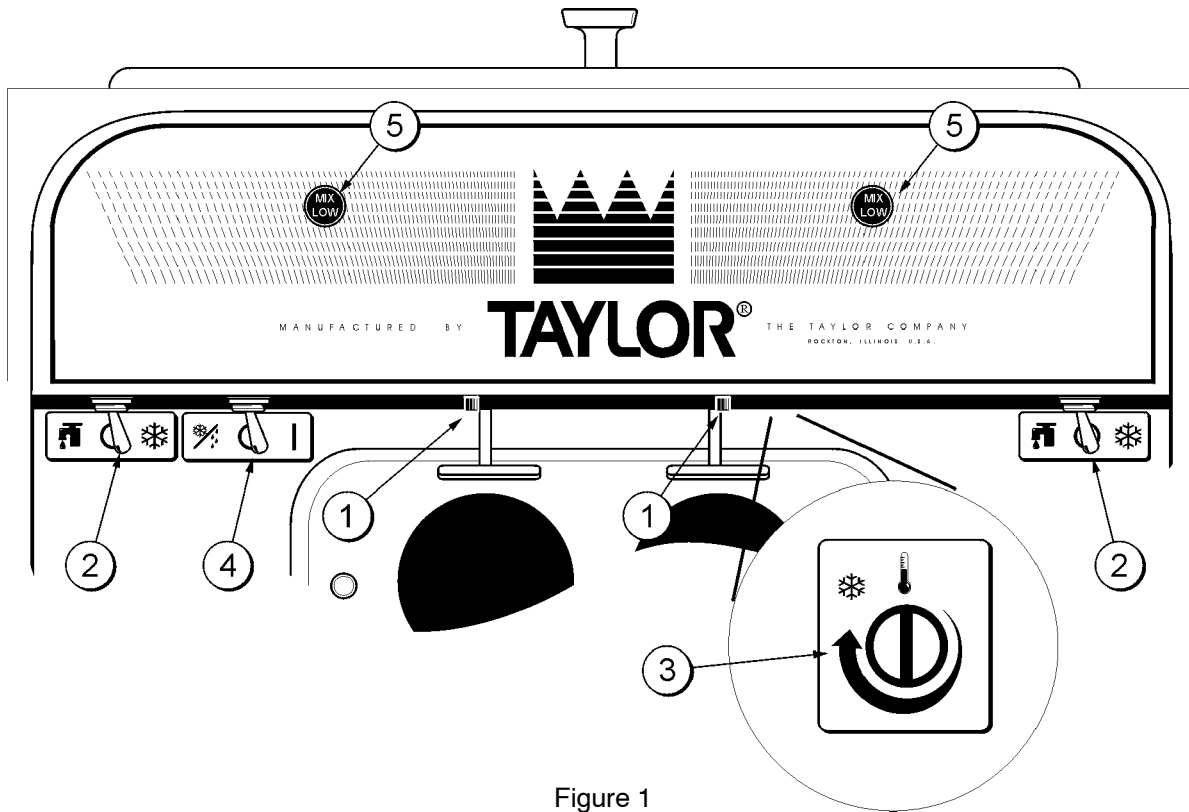







Figure 1

Item	Description
1	Push Button Switch
2	Power Switch
3	Temperature Control
4	Mix Refrigeration Switch
5	Indicator Lights - "Mix Low"

Symbol Definitions

To better communicate in the International arena, the words on many of our operator switches and buttons have symbols to indicate their functions. Your Taylor equipment is designed with these International symbols.

The following chart identifies the symbol definitions used on the operator switches.

-  = The ON/AUTO keypad.
-  = The ON keypad.
-  = The OFF keypad.
-  = The WASH keypad.
-  = The STANDBY keypad.

Push-Button Switch

If an overload condition occurs, the freezer will automatically stop operating. To properly reset the freezer, place the toggle switch in the "OFF" position. Wait two or three minutes; then press the push-button switch. Place the power switch in the "WASH" position and observe the freezer's performance; place the power switch in the "AUTO" position.

Note: If the freezer is unplugged from the wall receptacle, it will be necessary to press the push-button switch for the freezer to operate once power is re-established.

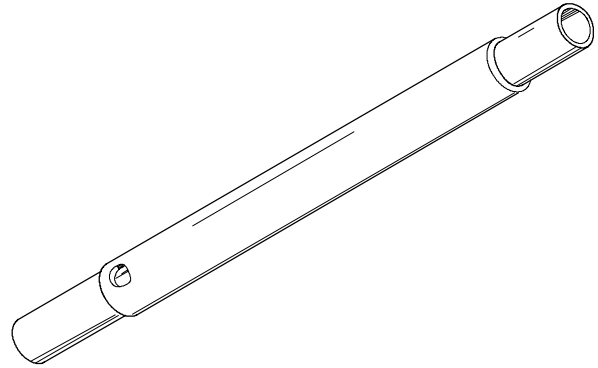

Figure 2

Power Switch

The center position is "OFF". The left position is "WASH" which activates the beater motor only. The right position is "AUTO", which activates the beater motor and the refrigeration system.

Note: During "AUTO" operation, the orifice end of the tube should be inserted in the hole in the hopper.

Temperature Control

The Models 150 and 152 use a temperature control to monitor the product in the freezing cylinder. Turning the adjusting knob **clockwise** will decrease the product temperature. Turning the adjusting knob **counterclockwise** will increase the temperature. Each quarter of a turn will vary the temperature approximately two degrees. DO NOT set the temperature control colder than 18°F (-8°C). Should you set the temperature colder than 18°F (-8°C), premature failure of the belts and of the beater motor may occur.

Taylor Quality Control

The Models 162 and 168 use a solid state control called the T.Q.C. The purpose of this solid state control is to sense the viscosity (thickness) of the product in the freezing cylinder. With the power switch in the "AUTO" position, the T.Q.C. will automatically keep the mix in the freezing cylinder at the proper viscosity and ready for serving.

The Models 150 and 152 are available with the T.Q.C. as an option.

Air Tube

The models 150, 152, 162 and 168 are called upon to handle a large variety of products (i.e., soft serve, yogurts, Italian ices, sherbets, etc.). Thus, the consistency of the mix you use will vary. The air tube meters a combination of mix and air into the freezing cylinder. If not enough mix enters the freezing cylinder, a freeze-up may occur, which will cause eventual damage to the beater. Depending upon the product being run, you may wish to contact your local authorized Taylor Distributor to make a slight adjustment in the air tube.

Indicator Light - "Mix Low"

A mix level indicating light is located at the front of the machine. When the light is on, it indicates that the mix hopper has a low supply of mix and should be refilled as soon as possible. Always maintain at least 2" (5.1 cm) of mix in the hopper. If you neglect to add mix, a freeze-up may occur. This will cause eventual damage to the beater assembly and to the freezer door.

Mix Refrigeration Switch

The mix refrigeration switch is located under the control channel and is used for several purposes:

1. For the unit to operate in the “AUTO” mode, the mix refrigeration switch must be “ON”.
2. For the separate hopper refrigeration system to operate, the mix refrigeration switch must be in the “ON” or the “STANDBY” position.
3. For the cylinder temperature retention system to operate, the power switch must be in the “AUTO” position and the mix refrigeration switch must be in the “STANDBY” position.

Separate Hopper Refrigeration (SHR)

This feature incorporates the use of a separate small refrigeration system to chill (on a limited basis) and to maintain the mix in the hopper to under 40°F (4.4°C) and assures bacterial control. To activate this system, place the power switch in the “AUTO” position and the mix refrigeration switch in the “AUTO” position. To operate this system in the “STANDBY” mode, place the power switch in the “AUTO” position and the mix refrigeration switch in the “STANDBY” position.

Cylinder Temperature Retention (CTR)

To maintain a good quality product during long “No Sale” periods, it will be necessary to warm the product in the freezing cylinder to approximately 35° to 40°F (1.7° to 4.4°C). This will prevent overbeating and product breakdown. The CTR is used in conjunction with the SHR to insure that the mix in the freezing cylinder is refrigerated during the “STANDBY” mode of operation.

To operate the “STANDBY” mode of operation:

Place the power switch in the “AUTO” position and the mix refrigeration switch in the “STANDBY” position. With sanitized hands, remove the air tube. Turn it over and place the end without the hole into the mix inlet hole.

To resume normal operation:

Leave the power switch in the “AUTO” position and place the mix refrigeration switch in the “AUTO” position. When the unit cycles off, the product in the freezing cylinder will be the correct viscosity. With sanitized hands, remove the air tube. Turn it over and place the end with the hole into the mix inlet hole.

Syrup Rail

These units are available with an optional syrup rail to store cold toppings for sundaes.

Section 6

Operating Procedures

The Model 150 has been selected to illustrate the pictured step-by-step operating procedures. All models in this manual are similar. They each have a 1.5 quart (1.4 liter) capacity freezing cylinder. The mix flows by gravity from the hopper to the freezing cylinder through an air tube.

The Model 150 is a console model with a single spout door.

The Model 152 is a counter model with a single spout door.

The Model 162 is a counter model and the Model 168 is a console model. Both have three spout doors. Two individual flavors are available from the end spouts, and an equal combination of both is dispensed through the center spout to create a twist effect.

For the Model 162 and 168, duplicate the procedures where they apply for the second freezing cylinder.

We begin our instructions at the point where we enter the store in the morning and find the parts disassembled and laid out to air dry from the previous night's cleaning.

These opening procedures will show you how to assemble these parts into the freezer, sanitize them, and prime the freezer with fresh mix in preparation to serve your first portion.

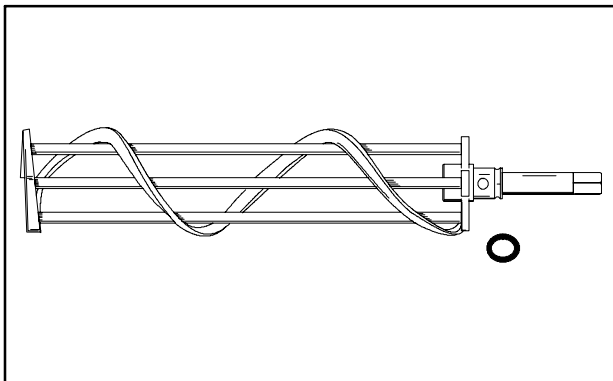

Figure 3

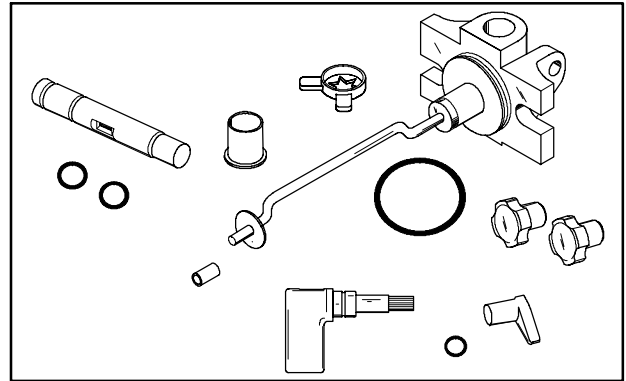

Figure 4

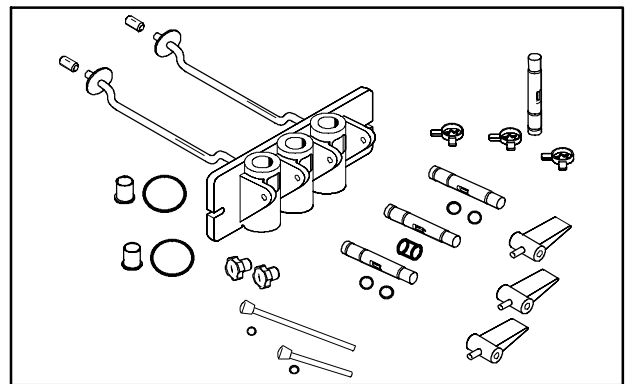

Figure 5

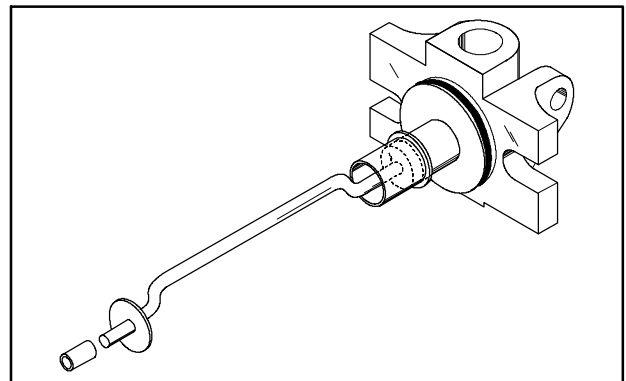

Figure 6

If you are disassembling the machine for the first time or need information to get to the starting point in our instructions, turn to page 21, "Disassembly", and start there.

Assembly

Note: When lubricating parts, use an approved food grade lubricant (example: Taylor Lube).

Step 1

Install the beater assembly. Slide the small, thick o-ring into the groove on the drive shaft of the beater assembly. Apply an even coat of Taylor Lube to the o-ring and the shaft.

DO NOT LUBRICATE THE HEX END.

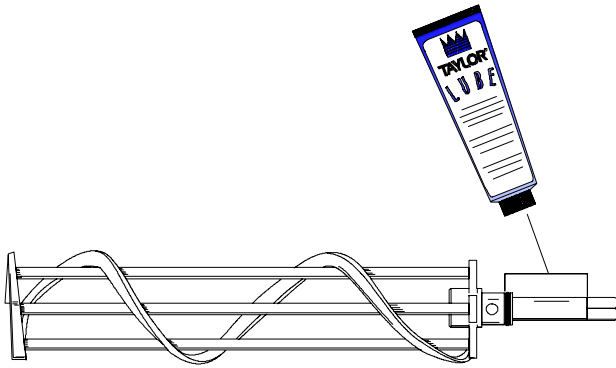

Figure 7

Insert the beater assembly through the rear shell bearing at the back of the freezing cylinder and engage the hex end firmly into the female socket. When properly seated, the beater will not protrude beyond the front of the freezing cylinder.

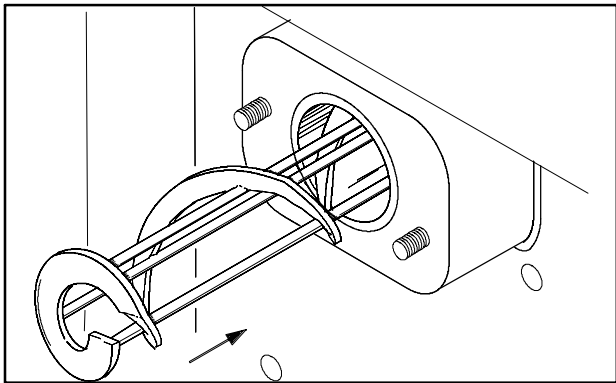

Figure 8

Repeat this step for the second freezing cylinder on Models 162/168.

Step 2

Assemble the freezer door. Place the large o-ring(s) into the groove(s) on the back of the freezer door and lubricate with Taylor Lube.

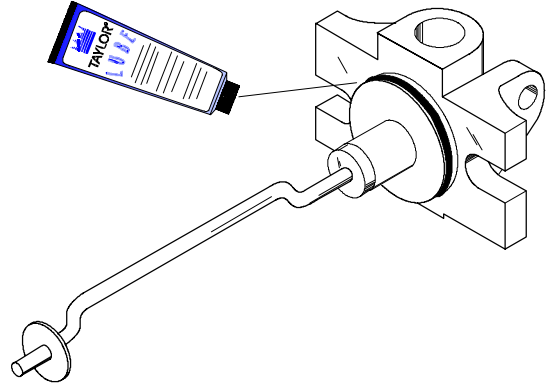

Figure 9

Slide the front bearing(s) over the baffle rod(s) so the flanged edge is against the door. Place the white plastic guide bearing(s) on the end of the baffle rod(s).

DO NOT LUBRICATE THE FRONT BEARING(S) OR THE GUIDE BEARING(S).

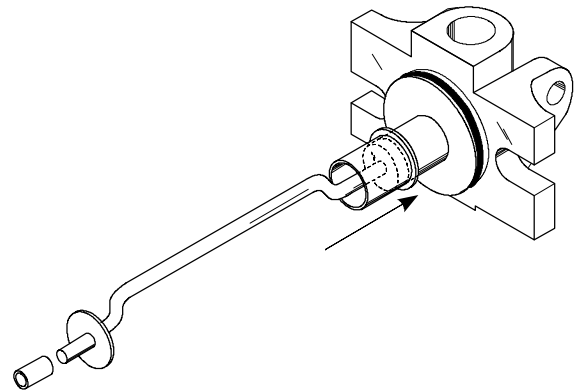

Figure 10

Step 3

Slide the slotted portion of the handscrews into the slots in the freezer door.

Step 4

Install the freezer door. With both hands, hold the sides of the freezer door and insert the baffle rod(s) into the center of the beater assembly(ies). The white guide bearing(s) must fit securely in the hole(s) of the drive shaft(s). Finger-tighten the handscrews equally to insure that the door is snug. **Do not over-tighten.**

Note: The freezer door is in the correct position when the door spout is on the bottom.

Step 5

Install the draw valve(s). Slide the two o-rings into the grooves on the draw valve(s) and lubricate with Taylor Lube.



Step 6

Install the draw valve handle. Insert the valve lifter arm through the slotted opening in the draw valve and align the other end with the cross holes of the freezer door.

Hint: The valve lifter arm may be aligned with the left or right cross hole. The draw valve handle will be placed through the opposite cross hole of the valve lifter arm.

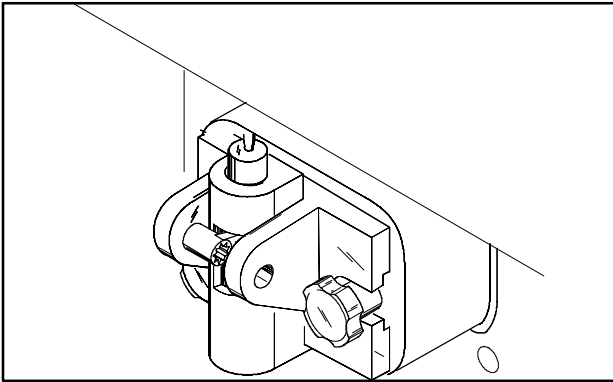

Figure 15

Slide the o-ring into the groove on the draw valve handle and lubricate with Taylor Lube.

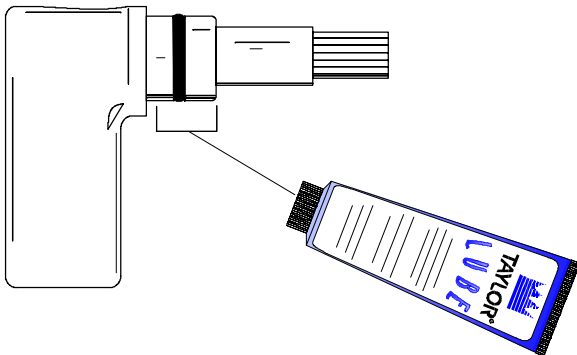

Figure 16

Insert the draw valve handle through the opposite cross hole and into the opening of the valve lifter arm.

Hint: The draw valve handle can be assembled at varied vertical positions. Choose an angle which is comfortable for you. The draw valve must be raised completely when the draw valve handle is down.

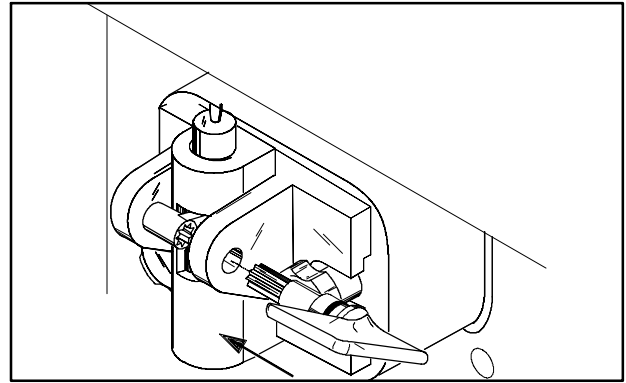

Figure 17

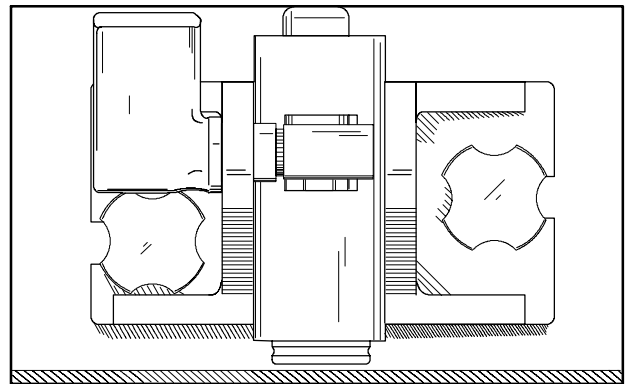

Figure 18

Note: For Models 162/168, slide the o-ring onto each pivot pin and lubricate with Taylor Lube.

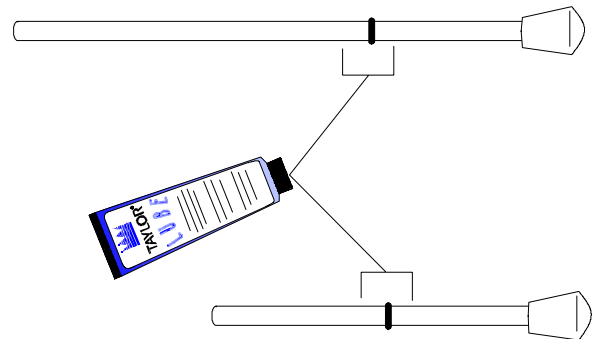

Figure 19

Note: Models 162/168 have three draw handles. Slide the tip of the draw handle into the slot of the draw valve, starting from the right. Slide the short pivot pin through the far right draw handle. Slide the long pivot pin through the far left and middle draw handles.

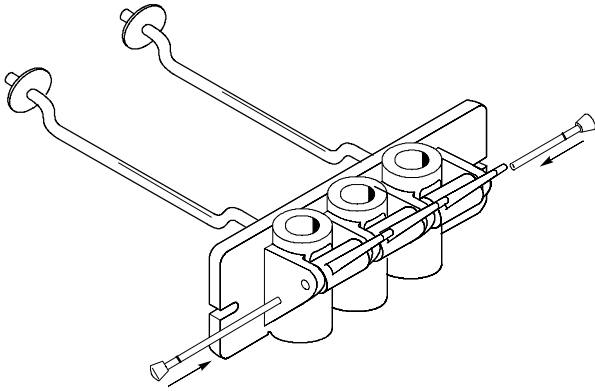

Figure 20

Step 7
Snap the design cap(s) over the bottom of the freezer door spout(s).

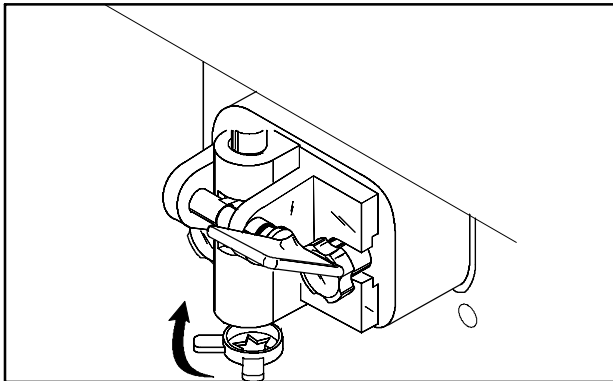

Figure 21

Step 8
Lay the air tube(s) in the bottom of the mix hopper(s).

Sanitizing

Step 1

Prepare one gallon (3.8 liters) of an approved 100 PPM sanitizing solution (example: Kay-5™). USE WARM WATER AND FOLLOW THE MANUFACTURER'S SPECIFICATIONS.

Step 2

Pour one gallon (3.8 liters) of sanitizing solution into the hopper and allow it to flow into the freezing cylinder.

Step 3

While the solution is flowing into the freezing cylinder, brush-clean the mix hopper, mix level float stem, mix level float, mix inlet hole, and air tube.

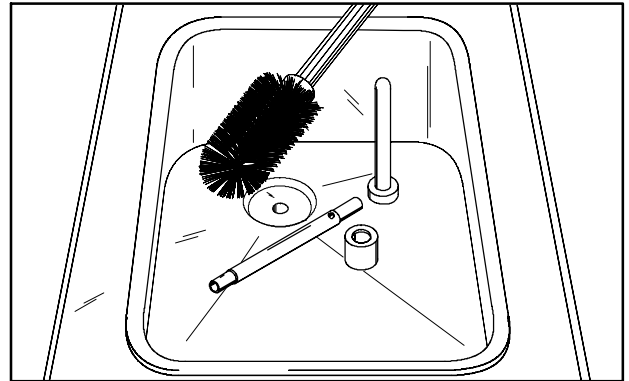
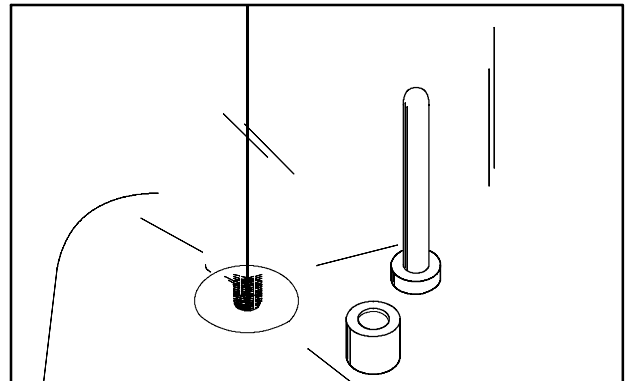

Figure 22



Priming

Prime the machine as close as possible to the time of first product draw.

Step 1

With a pail beneath the door spout, raise the draw valve. Fill the mix hopper with **fresh** mix. (Maximum hopper capacity is 8 quarts [7.6 liters].) Allow the mix to flow into the freezing cylinder. This will force out any remaining sanitizing solution. When full strength mix is flowing from the door spout, lower the draw valve.

Note: Use only FRESH mix when priming the freezer.

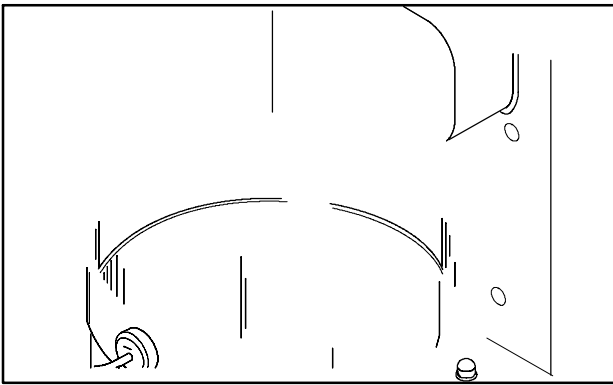

Step 6

Slide the rear drip pan into the hole in the side panel.

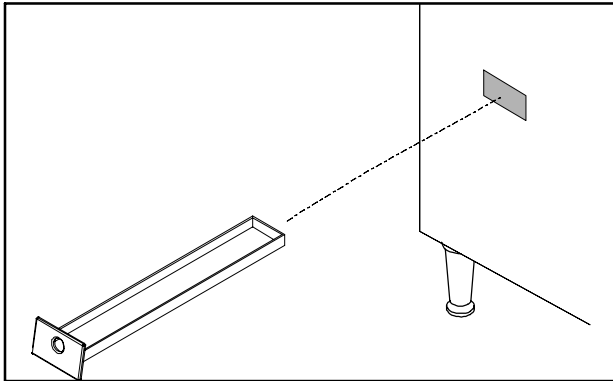

Figure 33

Closing Procedure

To disassemble the Models 150/152/162/168, the following items will be needed:

- Two cleaning pails
- Sanitized stainless steel rerun can with lid
- Necessary brushes (provided with freezer)
- Cleaner
- Single service towels

Draining Product From the Freezing Cylinder

Step 1

Place the power switch in the “OFF” position as far ahead of cleaning time as possible. This will allow frozen product to soften for easier cleaning.

Step 2

Lift the hopper cover. Remove the air tube and mix level float. Take them to the sink for cleaning.

Step 3

With a sanitized pail beneath the door spout, place the power switch in the “WASH” position and raise the draw valve. When all the product stops flowing from the door spout, lower the draw valve and place the power switch in the “OFF” position. If local health codes permit, empty the rerun into a sanitized stainless steel rerun can. Cover the container and place it in the walk-in cooler.



ALWAYS FOLLOW LOCAL HEALTH CODES.

Repeat Steps 1 through 3 for the second freezing cylinder on Models 162/168.

Rinsing

Step 1

Pour one gallon (3.8 liters) of **cool**, clean water into the mix hopper. With the brushes provided, scrub the mix hopper, the mix level float stem and the mix inlet hole.

Step 2

With a pail beneath the door spout, place the power switch in the “WASH” position and raise the draw valve. Drain all the rinse water from the freezing cylinder. When the rinse water stops flowing from the door spout, lower the draw valve and place the power switch in the “OFF” position.

Repeat this procedure until the rinse water being drawn from the freezing cylinder is **clear**.

Repeat Steps 1 and 2 for the second freezing cylinder on Models 162/168.

Cleaning

Step 1

Prepare one gallon (3.8 liters) of an approved cleaning solution (example: Kay-5™). **USE WARM WATER AND FOLLOW THE MANUFACTURER'S SPECIFICATIONS.**

Step 2

Pour the one gallon (3.8 liters) of cleaning solution into the mix hopper and allow it to flow into the freezing cylinder.

Step 3

While the solution is flowing into the freezing cylinder, brush-clean the mix hopper, mix level float stem and mix inlet hole.

Step 4

Place the power switch in the “WASH” position. This will cause the cleaning solution in the freezing cylinder to agitate.

Step 5

Place an empty pail beneath the door spout and raise the draw valve. Draw off all the cleaning solution.

When the solution stops flowing from the door spout, lower the draw valve and place the power switch in the "OFF" position.

Repeat Steps 1 through 5 for the other side of the freezer on Models 162/168.

Disassembly

Step 1

BE SURE THE POWER SWITCH IS IN THE "OFF" POSITION.

Step 2

Remove the handscrews and the freezer door. Remove the beater assembly(ies) from the freezing cylinder(s) and take these parts to the sink for cleaning.

Step 3

Remove the front drip tray and the splash shield from the freezer. Take them to the sink for cleaning.

Brush Cleaning

Step 1

Prepare a sink with an approved cleaning solution. USE WARM WATER AND FOLLOW THE MANUFACTURER'S SPECIFICATIONS.

IMPORTANT: Follow label directions, as too STRONG of a solution can cause parts damage, while too MILD of a solution will not provide adequate cleaning.) Make sure all brushes provided with the freezer are available for brush cleaning.

Step 2

Remove the o-ring(s) from the drive shaft(s) of the beater assembly(ies).

Note: To remove the o-rings, use a single service towel to grasp the o-ring. Apply pressure in an upward direction until the o-ring pops out of its groove. With the other hand, push the top of the o-ring forward, and it will roll out of the groove and can be easily removed. If there is more than one o-ring to be removed, always remove the rear o-ring first. This will allow the o-ring to slide over the forward rings without falling into the open grooves.

Step 3

From the freezer door, remove the design cap, draw valve handle, valve lifter arm, and draw valve. Remove all o-rings.

Models 162/168: From the freezer door, remove design caps, pivot pins, draw handles, draw valves, and the center draw valve. Remove all o-rings.

Step 4

Remove the large o-ring(s), front bearing(s), and guide bearing(s) from the back of the freezer door.

Step 5

Return to the freezer with a small amount of cleaning solution. With the black bristle brush, brush clean the rear shell bearing(s) at the back of the freezing cylinder(s).

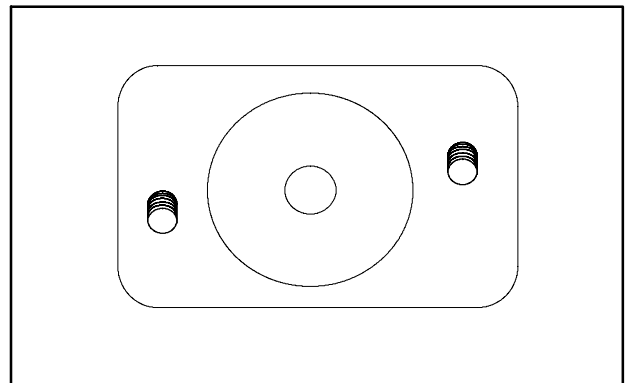

Section 7 Important: Operator Checklist

During Cleaning and Sanitizing



ALWAYS FOLLOW LOCAL HEALTH CODES.

Cleaning and sanitizing schedules are governed by federal, state, or local regulatory agencies, and must be followed accordingly. If the unit has a “Standby mode”, it must not be used in lieu of proper cleaning and sanitizing procedures and frequencies set forth by the ruling health authority. The following check points should be stressed during the cleaning and sanitizing operations.



CLEANING AND SANITIZING MUST BE PERFORMED DAILY.

Troubleshooting Bacterial Count

- 1. Thoroughly clean and sanitize the machine regularly, including complete disassembly and brush cleaning.
- 2. Use all brushes supplied for thorough cleaning. The brushes are specially designed to reach all mix passageways.
- 3. Use the smaller, white bristle brush to clean the mix inlet hole which extends from the mix hopper down to the rear of the freezing cylinder.
- 4. Use the black bristle brush to thoroughly clean the rear shell bearing located at the rear of the freezing cylinder. Be sure to have a generous amount of cleaning solution on the brush.

- 5. IF LOCAL HEALTH CODES PERMIT THE USE OF RERUN, make sure the mix rerun is stored in a sanitized, covered stainless steel container and is used the following day. DO NOT prime the machine with rerun. When using rerun, skim off the foam and discard. Mix the rerun with fresh mix in a ratio of 50/50 during the day's operation.
- 6. On a designated day of the week, run the mix as low as feasible and discard after closing. This will break the rerun cycle and reduce the possibility of high bacteria and coliform counts.
- 7. Properly prepare the cleaning and sanitizing solutions. Read and follow label directions carefully. Too strong of a solution may damage the parts and too weak of a solution will not do an adequate job of cleaning or sanitizing.
- 8. The temperature of the mix in the mix hopper and walk-in cooler should be below 40°F. (4.4°C.).

Regular Maintenance Checks

- 1. Check the rear shell bearing for signs of wear (excessive mix leakage in rear drip pan) and be certain it is properly cleaned.
- 2. Using a screwdriver and cloth towel, keep the rear shell bearing and the female hex drive socket clean and free of lubricant and mix deposits.
- 3. Dispose of o-rings or seals if they are worn, torn, or fit too loosely, and replace with new ones.
- 4. Follow all lubricating procedures as outlined in “Assembly”.

- 5. If your machine is air cooled, check the condenser for an accumulation of dirt and lint. A dirty condenser will reduce the efficiency and capacity of the machine. Condensers should be cleaned **monthly** with a soft brush. **Never** use screwdrivers or other metal probes to clean between the fins. Failure to comply may result in electrocution.
Note: For machines equipped with an air filter, it will be necessary to vacuum clean the filters on a monthly schedule.
- 6. If your machine is equipped with an auxiliary refrigeration system, check the condenser for accumulation of dirt and lint. A dirty condenser will reduce the refrigeration capacity of the mix hopper. Condensers must be cleaned **monthly** with a soft brush. **Never** use screwdrivers or other metal probes to clean between the fins. Failure to comply may result in electrocution.
- 7. If your machine is water cooled, check the water lines for kinks or leaks. Kinks can occur when the machine is moved back and forth for cleaning or maintenance purposes. Deteriorated or cracked water lines should be replaced only by an authorized Taylor mechanic.

Winter Storage

If the place of business is to be closed during the winter months, it is important to protect the freezer by following certain precautions, particularly if the building is subject to freezing conditions.

Disconnect the freezer from the main power source to prevent possible electrical damage.

On water cooled freezers, disconnect the water supply. Relieve pressure on the spring in the water valve. Use air pressure on the outlet side to blow out any water remaining in the condenser, and then add a liberal amount of permanent type auto anti-freeze. **This is extremely important.** Failure to follow this procedure may cause severe and costly damage to the refrigeration system.

Your local Taylor distributor can perform this service for you.

Wrap detachable parts of the freezer such as the beater assembly and freezer door, and place them in a protected dry place. Rubber trim parts and gaskets can be protected by wrapping them with moisture-proof paper. All parts should be thoroughly cleaned of dried mix or lubrication accumulations which attract mice and other vermin.

Section 8

Troubleshooting Guide

PROBLEM	PROBABLE CAUSE	REMEDY	PAGE REF.
1. No product being dispensed.	<ul style="list-style-type: none"> a. The power switch is in the "OFF" position. b. The mix level is inadequate in the mix hopper. c. The beater motor overloaded. d. The unit is unplugged at the wall receptacle. e. The circuit breaker is tripped or the fuse is blown. f. The freezer door is incorrectly assembled. g. Product is being drawn off in excess of the freezer's capacity. 	<ul style="list-style-type: none"> a. Place the power switch in the "AUTO" position. b. Fill the mix hopper with mix. c. Reset the freezer. d. Plug in the power cord. Press the push-button switch. e. Place the circuit breaker in the "ON" position, or replace the fuse. Press the push-button switch. f. See "Operating Procedures" for proper installation. g. Stop drawing product and allow the unit to recover. 	<ul style="list-style-type: none"> 19 19 11 11 11 14 - - -
2. The machine will not operate in the "AUTO" mode.	<ul style="list-style-type: none"> a. The unit is unplugged. b. The refrigeration system is not activated. c. The circuit breaker is tripped, or the fuse is blown. d. The beater motor overloaded, causing a loss of power to the power switch. 	<ul style="list-style-type: none"> a. Plug in the power cord; press the push-button switch. b. On T.Q.C. units, momentarily raise the draw switch to activate the refrigeration system. c. Place the circuit breaker in the "ON" position, or replace the fuse. Press the push-button switch. d. Reset the freezer. 	<ul style="list-style-type: none"> 11 19 11 11
3. The product is too stiff.	<ul style="list-style-type: none"> a. The temperature control or the T.Q.C. is set too cold. 	<ul style="list-style-type: none"> a. Adjust the temperature control. Do not set the temperature colder than 18°F (-8°C). If T.Q.C., contact service technician. 	<ul style="list-style-type: none"> 11

PROBLEM	PROBABLE CAUSE	REMEDY	PAGE REF.
4. The product is too soft.	a. The temperature control or the T.Q.C. is set too warm.	a. Adjust the temperature control. If T.Q.C., contact service technician.	11
	b. The air tube is not installed.	b. Install the air tube in the mix inlet hole at the bottom of the mix hopper.	19
	c. Out-drawing the freezer's capacity.	c. Two 4 oz. (113.4 gram) servings in one minute.	---
5. The freezing cylinder walls are scored.	a. Operating freezer without the front bearing on the freezer door.	a. Install the front bearing on the freezer door.	14
	b. The gear unit or the direct drive is out of alignment.	b. Contact service technician.	---
6. Excessive leakage in rear drip pan.	a. A worn or defective o-ring is on the beater drive shaft.	a. Replace o-rings every 3 months.	27
	b. The rear shell bearing is worn.	b. Contact service technician.	---
	c. Incorrect lubricant was used.	c. Use food grade lubricant (example: Taylor Lube).	14
	d. Inadequate lubrication of beater drive shaft.	d. Lubricate the beater drive shaft properly.	14
7. The draw valve is leaking.	a. Incorrect lubricant was used.	a. Use food grade lubricant (example: Taylor Lube).	15
	b. Worn or defective o-rings are on the draw valve.	b. Replace o-rings every 3 months.	27
	c. Inadequate lubrication of draw valve.	c. Lubricate the draw valve properly.	15
8. Product is not feeding into the freezing cylinder.	a. The mix level is inadequate in the mix hopper.	a. Fill the mix hopper with mix.	19
	b. The mix inlet hole is frozen.	b. Contact service technician.	11

PROBLEM	PROBABLE CAUSE	REMEDY	PAGE REF.
9. The unit goes out on overload excessively.	<ul style="list-style-type: none"> a. There are too many appliances plugged into the circuit. b. An extension cord has been placed between the power cord and the wall receptacle. 	<ul style="list-style-type: none"> a. A separate 20 amp. circuit is needed for the freezer to operate properly. b. If the extension cord is used, it must match the power cord in size of circuit ampacity. 	<p style="text-align: center;">---</p> <p style="text-align: center;">---</p>
10. Models 162 and 168: Mix from one freezing cylinder bleeds over to the second cylinder.	<ul style="list-style-type: none"> a. The center draw valve seal is worn, or is improperly lubricated. 	<ul style="list-style-type: none"> a. Lubricate properly and replace seal every 3 months. 	15 / 27

Section 9

Parts Replacement Schedule

PART DESCRIPTION	EVERY 3 MONTHS	EVERY 6 MONTHS	ANNUALLY	QTY.	
				150/152	162/168
Beater Drive Shaft O-Ring	X			1	2
Freezer Door O-Ring	X			1	2
Freezer Door Front Bearing	X			1	2
Freezer Door Guide Bearing	X			1	2
Draw Valve O-Ring	X			2	4
Draw Valve Handle O-Ring	X			1	-
Center Draw Valve Seal	X			-	1
Pivot Pin O-Ring	X			-	2
Black Bristle Brush, 1" x 2"		Inspect & Replace if Necessary	Minimum	1	1
Double Ended Brush		Inspect & Replace if Necessary	Minimum	1	1
White Bristle Brush, 1" x 2"		Inspect & Replace if Necessary	Minimum	1	1
White Bristle Brush, 3" x 7"		Inspect & Replace if Necessary	Minimum	1	1

Section 10

Parts List

DESCRIPTION	PART NUMBER	150 QTY.	152 QTY.	162 QTY.	168 QTY.	WARR. CLASS	REMARKS	PARTS UPDATE
BEARING-FRONT	023262	1	1	2	2	000		
BEARING-GUIDE	014496	1	1	2	2	000		
BEARING-REAR SHELL *150-52-68*	023648	1	1	2	2	000		
+ NUT-REAR BEARING *150-52-68*	023647	1	1	2	2	000		
+ TAB-BEARING LOCK *150-2-68*	025027	1	1	2	2	000		
BEARING-UNIT REAR	024764	1				103		
BEATER A. *150-2-162-168*	X24689	1	1	2	2	103		
+ O-RING-13/16 OD X .139W	021278	1	1	2	2	000		
BELT-AX23	041137			2		000		
BELT-POLY V-280J10	025776		1			000		
BELT-POLY V-580J10	025551	1				000		
BELT-POLY V-460J10	028182				2	000		
BLOCK-TERMINAL 2P	039422			1	1	103		
BLOCK-TERMINAL 5 POLE	024329	1			4	103		
BLOCK-TERMINAL 7 POLE	025156			1	1	103	115-60-1	
BRUSH-DOUBLE ENDED-PUMP&FEED T	013072	1	1	1	1	000		
BRUSH-DRAW VALVE 1"ODX2"X17"L	013073	1	1	1	1	000		
BRUSH-MIX PUMP BODY-3"X7"WHITE	023316	1	1	1	1	000		
BRUSH-REAR BRG 1IN.DX2IN.LGX14	013071	1	1	1	1	000		
CAP-DESIGN-1.010"ID-6 POINT	014218	1	1	3	3	000		
CASTER-RIGID 3 IN. WHL	012226	2			2	103	REAR	
CASTER-SWIVEL 3 IN. WHEEL	012227	2			2	103	FRONT	
COMPRESSOR AKA9462ZXA-AK172AT	049302-	1				512	MAIN	
+ CAPACITOR-RUN- 25UF/370VAC	023739	1				103	115-60-1	
+ CAPACITOR-START- 72-88UF/250V	039557-27	1				103	115-60-1	
+ RELAY-START-COMPRESSOR	045432-12	1				103	115-60-1	
+ CAPACITOR-RUN- 15UF/370V	027087	1					230-60-1	
+ CAPACITOR-START- 72-88UF/330V	039567	1					230-60-1	
+ RELAY-START-COMPRESSOR	048150	1					230-60-1	
COMPRESSOR AJB7461JXA-AJ556BT	047607-		1			512	MAIN HP81	
+ CAPACITOR-RUN- 15UF/370V	027087		1			103	115-60-1	
+ CAPACITOR-START-340-408UF/165V	047608		1			103	115-60-1	

+ Available Separately

DESCRIPTION	PART NUMBER	150 QTY.	152 QTY.	162 QTY.	168 QTY.	WARR. CLASS	REMARKS	PARTS UPDATE
+ RELAY-START-COMPRESSOR	047609		1			103	115-60-1	
+ CAPACITOR-RUN- 15UF/370V	027087		1			103	230-60-1	
+ CAPACITOR-START-161-193UF/250V	031790		1			103	230-60-1	
+ RELAY-START-COMPRESSOR	031789		1			103	230-60-1	
COMPRESSOR AKA9462ZXD-AK172ET	049302-			2	2	512	MAIN	
+ CAPACITOR-RUN- 25UF/370VAC	023739			2	2	103	115-60-1	
+ CAPACITOR-START- 72-88UF/250V	039557-27			2	2	103	115-60-1	
+ RELAY-START-COMPRESSOR	045432-12			2	2	103	115-60-1	
+ CAPACITOR-RUN- 15UF/370V	027087			2	2	103	230-60-1	
+ CAPACITOR-START- 72-88UF/330	039567			2	2	103	230-60-1	
+ RELAY-START-COMPRESSOR	048150			2	2	103	230-60-1	
COMPRESSOR-TL2.5F-R134A	047701-	1		1	1	512	SHR	
+ RELAY-START-COMPRESSOR	027714-12	1		1	1	103	115-60-1	
+ RELAY-START-COMPRESSOR-TL3G	047702-27	1		1	1	103	230-60-1	
+ CAPACITOR-START-60UF -220/275V	047703	1		1	1	103	230-60-1	
CONDENSER-AC-12LX14HX1.87T 3RW	046556	1	1			103		
CONDENSER-AC-7X8X1.25-2 ROW	027155	1		1	1	103	SHR	
CONDENSER-AC-9HX24WX2.5T-4 ROW	047146			1		103		
CONDENSER-AC-15LX14HX2.57-4R	047255				1	103		
CONTROL-TEMP.	028914	2		2	2	103	SHR & STANDBY	
CONTROL A.-TEMPERATURE	X14383		1			103	HP81	
+ BRACKET-RANCO *150-68*	025683		1			103		
+ KNOB-TEMPERATURE CONTROL	013731		1			103		
CONTROL-VISCOSITY-WATT	X37260SER1	1		2	2	103	115 VOLT	
CONTROL-VISCOSITY-WATT	X37260SER2	1		2	2	103	230 VOLT	
CORD-POWER	025340-	1	1			103		
COVER A.-HOPPER *M150-152	X48690	1	1			103		
+ KNOB-MIX COVER	025429	1	1	1		103		
COVER A.-HOPPER *162-168*	X37963			1	1	103	INCLUDES KNOB	
KNOB-MIX COVER	025429	1	1	1	1	103		
DAMPER A.-FOR USE ON 25W ONLY	X20320	1				103		
DECAL-CLEAN INST.-HOPPER	019029	1	1	1	1	000		
DECAL-DEC-TAYLOR 150/152	047667	1	1			000		

+ Available Separately

DESCRIPTION	PART NUMBER	150 QTY.	152 QTY.	162 QTY.	168 QTY.	WARR. CLASS	REMARKS	PARTS UPDATE
DECAL-DEC-TAYLOR 162/168	047666			1	1	000		
DECAL-MIX REF. STANDBY OFF-ON	022177	1		1	1	000		
DECAL-TROUBLESHOOTING	038374	1	1	1	1	000		
DECAL-WARNING *PANEL*	036529	3		3	3	000		
DECAL-WASH-OFF-AUTO	014502	1	1	2	2	000		
DECAL-WARM-COLD	013749		1			000	HP81	
DIAGRAM-WIRING *150*	050416-	1				000		
DIAGRAM-WIRING *150*	047514		1			000	HP81	
DIAGRAM-WIRING	050205-			1		000		
DOOR A.-1 SPOUT-1.5 QT	X38959-SER	1	1			103		
ARM-VALVE LIFTER	024761	1	1			103		
HANDLE-DRAW	024762	1	1			103		
O-RING-2-3/4 OD X .139W	019998	1	1			000		
O-RING-3/4 OD X .103W	015835	1	1			000		
O-RING-7/8 OD X .103W	014402	2	2			000		
VALVE-DRAW *150-2*	024763	1	1			103		
DOOR A.-3 SPOUT	X30753-SER			1	1	103		
HANDLE-DRAW VALVE	030564			3	3	103		
O-RING-2-3/4 OD X .139W	019998			2	2	000		
O-RING-5/16 OD X .070W	016272			2	2	000		
PIN A.-PIVOT-LONG	X38538			1	1	103		
PIN A.-PIVOT-SHORT	X38539			1	1	103		
SEAL-DRIVE SHAFT	030930			1	1	000		
VALVE-DRAW *150-2*	024763			2	2	103		
VALVE-DRAW -CENTER	031164			1	1	103		
DRYER-CAP. TUBE .026 ID X 11FT	048894	1				000	SHR	
DRYER-CAP. TUBE-HP62/R134A	047699			1	1	000	SHR	
DRYER-CAP. TUBE-HP62/R134A	048255			1	1	000	SHR 115-60-1 ONLY	
DRYER-FILTER-HP62-3/8 X 1/4S	048901	1		2	2	000		
DRYER-FILTER 1/4 X 1/4 SOLDER	041099		1			000	HP81	
FLOAT A. - MIX LEVEL *142*	X39690	1	1	2	2	103		
GASKET-HOPPER COVER-8QT	037042			1	1	000		
GEAR-REDUCER	025770		1	2	2	212		

+ Available Separately

DESCRIPTION	PART NUMBER	150 QTY.	152 QTY.	162 QTY.	168 QTY.	WARR. CLASS	REMARKS	PARTS UPDATE
GUARD-SWITCH *150-2*	025496	1	1			103		
GUARD-POWER & DANFOSS SWITCH	035548			1	1	103		
GUIDE A.-DRIP PAN	X28593		1			103		
HARNES A.-WIRE *150*162*LQSOL	X50224			1		103		
HOLDER-DRIP TRAY*150-2-68-756M	035866	2	2	2	2	103		
HOOD A. *150*	X49063	1				103		
HOOD A. *152*	X49065		1			103		
HOOD A. *162*	X35918			1		103		
HOOD A. *168*	X34846				1	103		
INSERT-FRONT PANEL *168*	030773-SS				1	103		
LABEL-CAUTION GROUND CORD UNIT	032165	1				000		
LABEL-DOOR CAUTION	032749	1				000		
LABEL-MIX COOLING ADJ.	020217	1		1	1	000		
LABEL-MOVING PARTS WARNING	024315	6		3		000		
LABEL-STD BY BARREL TEMP ADJ	029092			2	2	000		
LEG-4"-3/8-16 STUD-PLASTIC	024755		4			103		
LEG-4" SS-W/ORING	013458			4		103		
LIGHT-MIX LOW-AMBER ROUND-12V	039707	1		1	1	103		
LIGHT-MIX LOW-AMBER ROUND-24V	039708		1			103	HP81	
LUBRICANT-TAYLOR 4 OZ.	047518	1	1	1	1	000		
KIT A. - TUNE UP*150-152*	X25802	1	1			000		
CAP-DESIGN-1.010"ID-6 POINT	014218	1	1			000		
O-RING-7/8 OD X .103W	014402	2	2			000		
BEARING-GUIDE	014496	1	1			000		
O-RING-3/4 OD X .103W	015835	1	1			000		
O-RING-2-3/4 OD X .139W	019998	1	1			000		
O-RING-13/16 OD X .139W	021278	1	1			000		
BEARING-FRONT	023262	1	1			000		
TOOL-CLEANING O-RING REMOVAL	048260	1	1			000		
KIT A.-TUNE UP*162-168*	X31167			1	1	000		
BEARING-FRONT	023262			2	2	000		
BEARING-GUIDE	014496			2	2	000		
CAP-DESIGN-1.010"ID-6 POINT	014218			3	3	000		

+ Available Separately

DESCRIPTION	PART NUMBER	150 QTY.	152 QTY.	162 QTY.	168 QTY.	WARR. CLASS	REMARKS	PARTS UPDATE
O-RING-13/16 OD X .139W	021278			2	2	000		
O-RING-2-3/4 OD X .139W	019998			2	2	000		
O-RING-5/16 OD X .070W	016272			2	2	000		
O-RING-7/8 OD X .103W	014402			4	4	000		
SEAL- VALVE	030930			1	1	000		
TOOL-CLEANING O-RING REMOVAL	048260			1	1	000		
MAN-OPER 150/152/162/168	028749-M	1	1	1	1	000		
MOTOR-1/2 HP	024839-	1	1	2	2	212		
MOTOR-FAN 17W/60HZ 2900RPM-CCW	027309-	1		1	1	103	SHR	
MOTOR-FAN 35W-40"LEADS	027817-	1	1			103		
+ FAN-4 BLADE 11 " PULL 30DEG CW	028405	1				103		
+ FAN-4 BLADE 11 " PUSH 30DEG CW	027818		1			103		
MOTOR-FAN-25W	015184-			2		103		
+ FAN-5 BLADE 8" PUSH 37 DEG CCW	047231			2		103		
MOTOR-FAN 120 W 208/230V 60H	041401-27				1	103		
+ BOOT-CAPACITOR INSULATING	031324				1	000		
+ CAPACITOR-RUN- 4UF-370V	019624				1	103		
+ FAN-5 BLADE 12"PUSH 32DEG CC	047279				1	103		
NUT-STUD *150- 152- 162- 168*	034829	2	2	2	2	103	HANDSCREWS	
PAIL-6 QT.	023348	1	1	1	1	000		
PAN-DRIP 11-5/8 LONG	027503	1	1			103		
PAN-DRIP 17-1/4"LONG	027504				1	103		
PAN-DRIP 19-1/2 LONG	035034			1		103		
PANEL A.-CONTROL LEFT *162*	X37190			1		103		
PANEL A.-CONTROL RIGHT *162*	X37191			1		103		
PANEL A.-FRONT *150-152*	X25036	1	1			103		
PANEL A.-FRONT *162-168	X30711			1	1	103		
PANEL A.-LOWER FRONT *150*	X25518	1				103		
PANEL A.-LOWER FRONT *168*	X30747				1	103		
PANEL-BACK BOTTOM *150*	050430	1				103		
PANEL-BACK TOP *150*	050429	1				103		
PANEL-BACK-152	025868-SS		1			103		
PANEL-BOTTOM BACK *168*	050244-SS				1	103		

+ Available Separately

DESCRIPTION	PART NUMBER	150 QTY.	152 QTY.	162 QTY.	168 QTY.	WARR. CLASS	REMARKS	PARTS UPDATE
PANEL-INSERT *150*	025533-SS	1				103		
PANEL-TOP BACK *168*	030790-SS				1	103		
PANEL-LOWER SIDE *150-168*	030792-SS	2			2	103		
PANEL-REAR *162AC*	047276-SS			1		103		
PANEL-SIDE-RIGHT-162	050213-SS			1		103		
PANEL-SIDE-RIGHT-152	025867-SS		1			103		
PANEL-SIDE-LEFT-152	028591-SS		1			103		
PANEL-SIDE-LEFT-162	050214-SS			1		103		
PANEL-FRONT LEFT *162*	035932-SS			1		103		
PANEL-FRONT RIGHT *162*	035933-SS			1		103		
PANEL-UPPER SIDE LEFT *150-68*	030783-SS	1			1	103		
PANEL-UPPER SIDE RIGHT *150-68*	030784-SS	1			1	103		
HARDWARE TO MOUNT PANELS								
+ BRACKET-PANEL *150-2*162-8*	030786	12	6	4	12	103		
+ FASTENER-DOOR LATCH	030787	12	6	4	12	000		
+ FASTENER-DOOR STRIKE	030788	12	6	4	12	000		
PLATE-DEC-150-152*MIX LOW	041034-SS	1	1			103		
PLATE-DEC-162-168*	039723-SS			1	1	103		
PLUG-DRIP TRAY HOLE	029595	1		1	1	000		
PULLEY-10J-1.125PD-5/8BORE	028857	1				103	BEATER MOTOR	
PULLEY-10J-12"PD-5/8BORE	025480	1				103	DIRECT DRIVE	
PULLEY-10J-1.5PD-5/8BORE	025479		1		2	103	BEATER MOTOR	
PULLEY-10J-4.50PD-5/8BORE	030455		1		2	103	GEAR REDUCER	
PULLEY-AK20X5/8	041162			2		103	BEATER MOTOR	
PULLEY-5.7" PITCH DIA X 5/8	041498			2		103	GEAR REDUCER	
RELAY-3 POLE	012725-	1		2	2	103		
RELAY-3 POLE	032666-		1			103		
RELAY-DPDT-20 A-120V	026581-	1		2	2	103		
SANITIZER KAY-5 125 PACKETS	041082	1	1	1	1	000		
SENSOR A.-MIX LEVEL	X39688	1	1	2	2	103		
SHELL A.-INSULATED *150*	X50378	1				512		
SHELL A.-INSULATED *150*	X43675		1			512	HP81	
SHELL A.-INSULATED *162/168*	X50150			1	1	512		

+ Available Separately

DESCRIPTION	PART NUMBER	150 QTY.	152 QTY.	162 QTY.	168 QTY.	WARR. CLASS	REMARKS	PARTS UPDATE
+ STUD-NOSE CONE-5/16-18X5/16-18	013496	2	2	2	2	103		
SHIELD-SPLASH 11-1/4 X 4-13/16	025063	1	1			103		
SHIELD-SPLASH *162-168*	030789			1	1	103		
SHROUD A.-CONDENSER *150*UPPER	X47506	1				103		
SHROUD A.-CONDENSER *168*AIR	X47370				1	103		
SHROUD-CONDENSER *150*	047511	1				103		
SHROUD-CONDENSER *150*FRIT/LEFT	047507	1				103		
SHROUD-CONDENSER *150*FRIT/RT	047508	1				103		
SHROUD-CONDENSER *152*	025880		1			103		
SHROUD-CONDENSER	047274			1		103	MAIN	
SHROUD-DANFOSS	027386	1		1	1	103	SHR	
SHROUD-FAN	047445		1			103		
SHROUD-REAR	030779				1	103		
SKIRT-AIR FLOW *162*HP82	049977			1		103		
SKIRT-AIR FLOW *162/168*	050243				1	103		
SWITCH A.-DRAW *150 SS W/TIMER	X32245-SER	1				103		
ACTUATOR-SWITCH	032247	1				103		
BRACKET-SWITCH *150*	032246	1				103		
E-RING 5/16	016422	1				000		
ROD-SWITCH *150-2*	029500	1				103		
SPRING-COMP.480X.047X2.00 SS	025452	1				103		
SWITCH-PLUNGER-SPDT15A125-250V	032260	2				103		
SWITCH A.-DRAW	X41224		1			103		
ROD-SWITCH	023663		1			103		
SPRING-COMP. 720 X .063 X 2.00	023664		1			103		
SWITCH-TANDEM-SPDT 20A 125-480	024849		1			103		
E-RING EXTERNAL 1/2	024908		1			000		
SWITCH A.-DRAW *168*	X32106-SER			2	2	103		
+ ARM A.-SWITCH *162-168*	X30736			2	2	103		
BEARING-SWITCH	029244			2	2	000		
BRACKET-SWITCH *168*	035524			1	1	103		
+ E-RING-1/4 IN-ZD	034962			2	2	000		
INSULATOR-SWITCH 1/64 ARMITE	029099			2	2	000		

+ Available Separately

DESCRIPTION	PART NUMBER	150 QTY.	152 QTY.	162 QTY.	168 QTY.	WARR. CLASS	REMARKS	PARTS UPDATE
NUT-PUSH ON-1/2DIA. SHAFT	039735			2	2	000		
SCREW-4-40X1 RH HD STEEL-ZP	028890			2	2	000		
+ SPRING-COMP-720X.063X2.00	023664			2	2	103		
+ SWITCH-ACTUATOR	035609			2	2	103		
SWITCH-LEVER-SPDT-15A-125-25	027214			2	2	103		
SWITCH-PRESSURE 440 PSI- SOLDER	048230	1		2	2	103		
SWITCH-PRESSURE 440 PSI-S	046362		1			103	HP81	
SWITCH-PUSHBUTTON-SPST	016530	1		2	2	103		
SWITCH- TOGGLE-DPDT*ON-OFF-ON	014464	2	1	2	2	103	POWER SWITCH	
SWITCH-TOGGLE-3PDT	017184			1		103	MIX CAN COOLING	
TEE-ACCESS 1/4	026686	1				103	SHR	
TIMER A.-CYCLE-14 MIN	X31959-	1		1	1	103		
TIMER-DELAY ON MAKE 2 SEC.	030667-12	1		1	1	103	115-60-1 ONLY	
TRANS.-CONT.-ANTICIPATOR 10 VA	010246-	1		1	1	103		
TRAY-DRIP 10-7/8 X 4-7/16	025062	1	1			103		
TRAY-DRIP-16-7/8L X 4-3/8	030565			1	1	103		
TRIM-MIDDLE BACK PANEL *168	030795				1	103		
TRIM-FRONT-SS	025862-SS		1			103		
TRIM-FRONT-SS	050212-SS			1		103		
TRIM-MIDDLE BACK PANEL *150*	025537	1				103		
TRIM-PANEL REAR *162*	035923			1		103		
TRIM-PANEL TOP BACK *168*	030775				1	103		
TRIM-SIDE & FRONT *150*	025528	1				103		
TRIM-SIDE & FRONT *168*	030774				1	103		
TRIM-TOP BACK	025866		1			103		
TRIM-TOP BACK PANEL *150*	025536	1				103		
TUBE-FEED-150-DANFOSS-.166HOLE	035819	1				103		
TUBE-FEED-SS-.166 HOLE*150*152	025061		1			103	HP81	
TUBE-FEED-SS-TM-TWIN	030797			2	2	103		
VALVE-ACCESS 1/4FL X 1/4S	044404				1	103		
VALVE-ACCESS 1/4FL X 3/8SDR-90	044455	1		1	1	103		
VALVE-ACCESS-1/4 MFLX1/4 S-90	047016	2	1	3	3	103		
VALVE-ACCESS-1/4FL X 3/8SDR-90	046903			1	1	103		

+ Available Separately

DESCRIPTION	PART NUMBER	150 QTY.	152 QTY.	162 QTY.	168 QTY.	WARR. CLASS	REMARKS	PARTS UPDATE
VALVE-EPR 1/4S	022665	1		1	1	103	SHR	
VALVE-EXP-AUTO-1/4S X 1/4FPT	047232	1	1	2	2	103		
+ BOOT-EXPANSION VALVE	027137	1	1	2	2	000		
VALVE-SOLENOID 7/64ORF X 1/4S	043449-	1	1	2	2	103		
VIDEO-TRAIN FILM-SS-TAYLORMATE	037665-V	1	1	1	1	000		
50 HZ								
BLOCK-TERMINAL-7 POLE GREEN	024156			1	3	103		
COMPRESSOR AKA9462ZXC-AK172JT	049302-40	1		2	2		MAIN 230-50-1	
+ CAPACITOR-RUN- 15UF/370V	027087	1		2	2		230-50-1	
+ CAPACITOR-START- 72-88UF/330V	039567	1		2	2		230-50-1	
+ RELAY-START-COMPRESSOR	041064	1		2	2		230-50-1	
COMPRESSOR AJB7461JXC-AJ556JT	027084-34		1			512	MAIN 230-50-1 HP81	
+ CAPACITOR-RUN- 15UF/370V	027087		1			103	230-50-1	
+ CAPACITOR-START-161-193UF/250V	031790		1			103	230-50-1	
+ RELAY-START-COMP. 3ARR3B3A4	023607-27		1			103	230-50-1	
DIAGRAM-WIRING	050205-40S				1	000		
MOTOR-FAN 100W 220-240V 50HZ	047178-34				1	000		
VIDEO-TRAIN FILM-SS-TAYLORMATE	037665-PAL	1	1	1	1	000		
SELF SERVE								
BLOCK-BACKUP-HOPPER LOCK	041176			2	2	103		
BLOCK-PIVOT-HOPPER LOCK	041175			1	1	103		
DECAL-MAG-FLAVOR PADS	044022			1	1	000		
DECAL-MAG-SLF SRV-TM-TWIN	044021			1	1	000		
GUARD-POWER SWITCH	034830			2	2	103		
HOOD A.*162 W/HOPPER LOCK STD.	X41195			1	1	103		
LOCK-KEY STYLE #1289	037362			1	1	103		
PCB A.-MIX LOW CHIME	X41243SER1			1	1	103	115 VOLT	
PIVOT-HOPPER LOCK	039035			1	1	103		
PLUG-BACKUP BLOCK	041177			4	4	103		

+ Available Separately

GROUND FRAME SECURELY

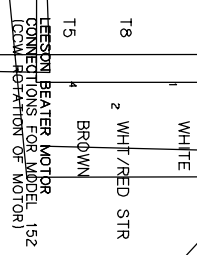
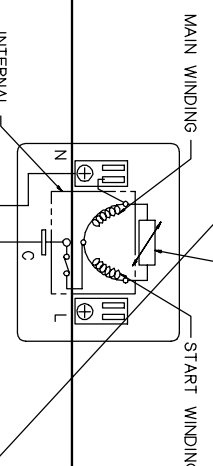
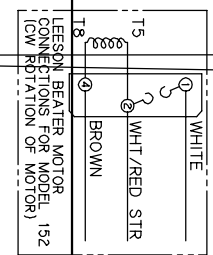
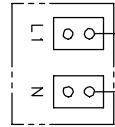
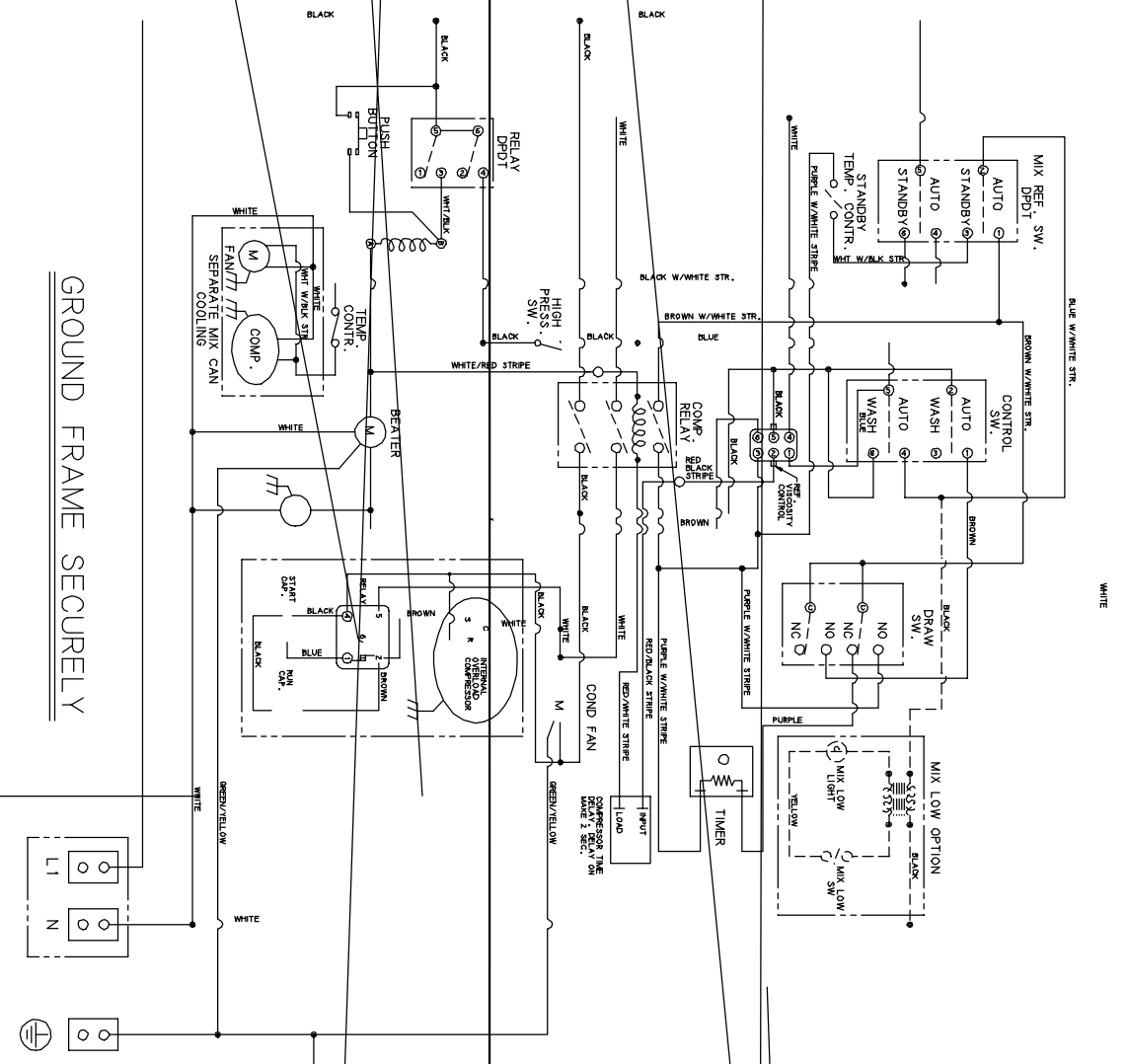

- TROL
- 1 L1
 - 2 N.C. CONTACT
 - 3 L2
 - 4 L2
 - 5 LINE
 - 6 LOAD

**Model 150
050416-12**

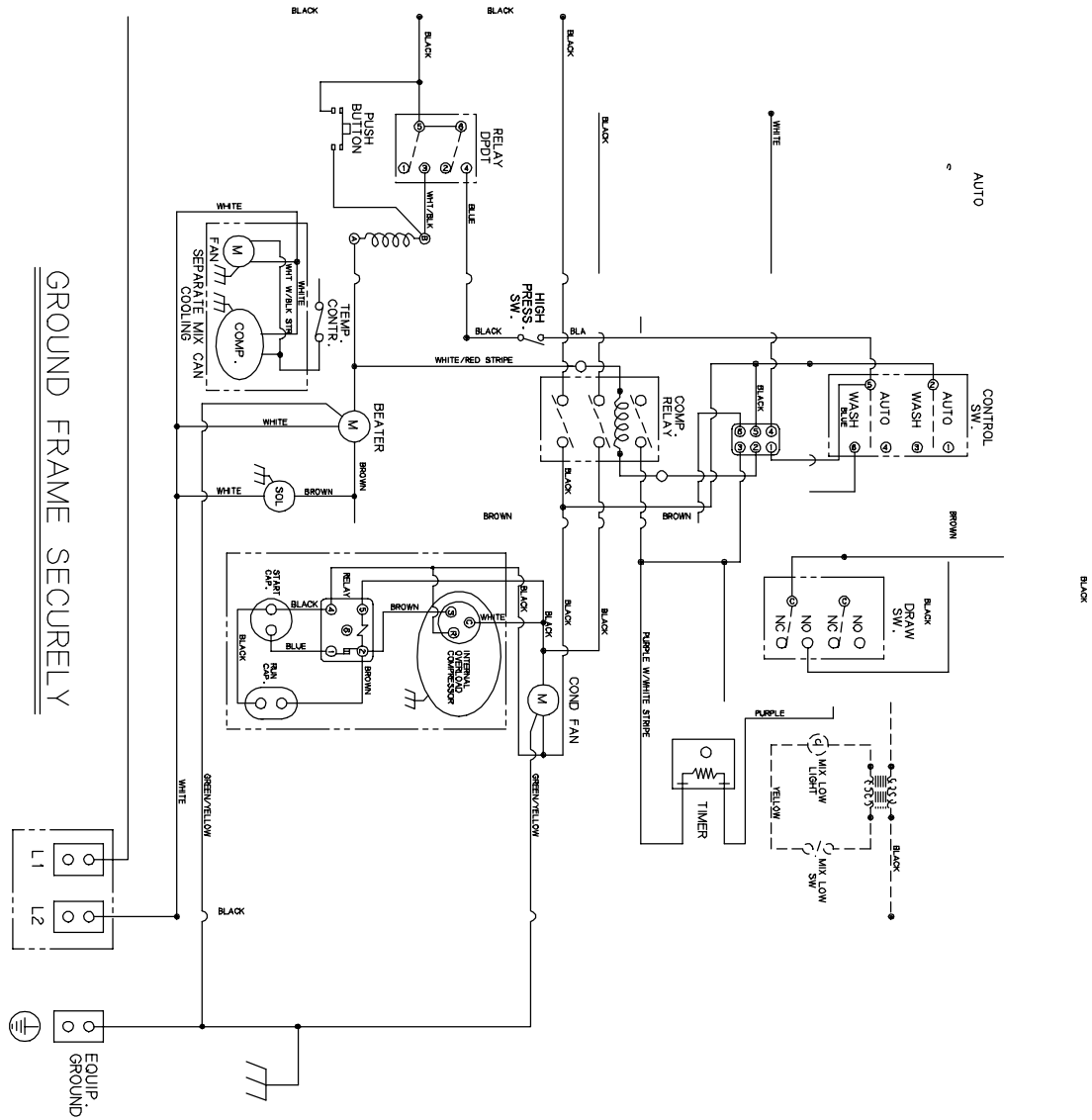

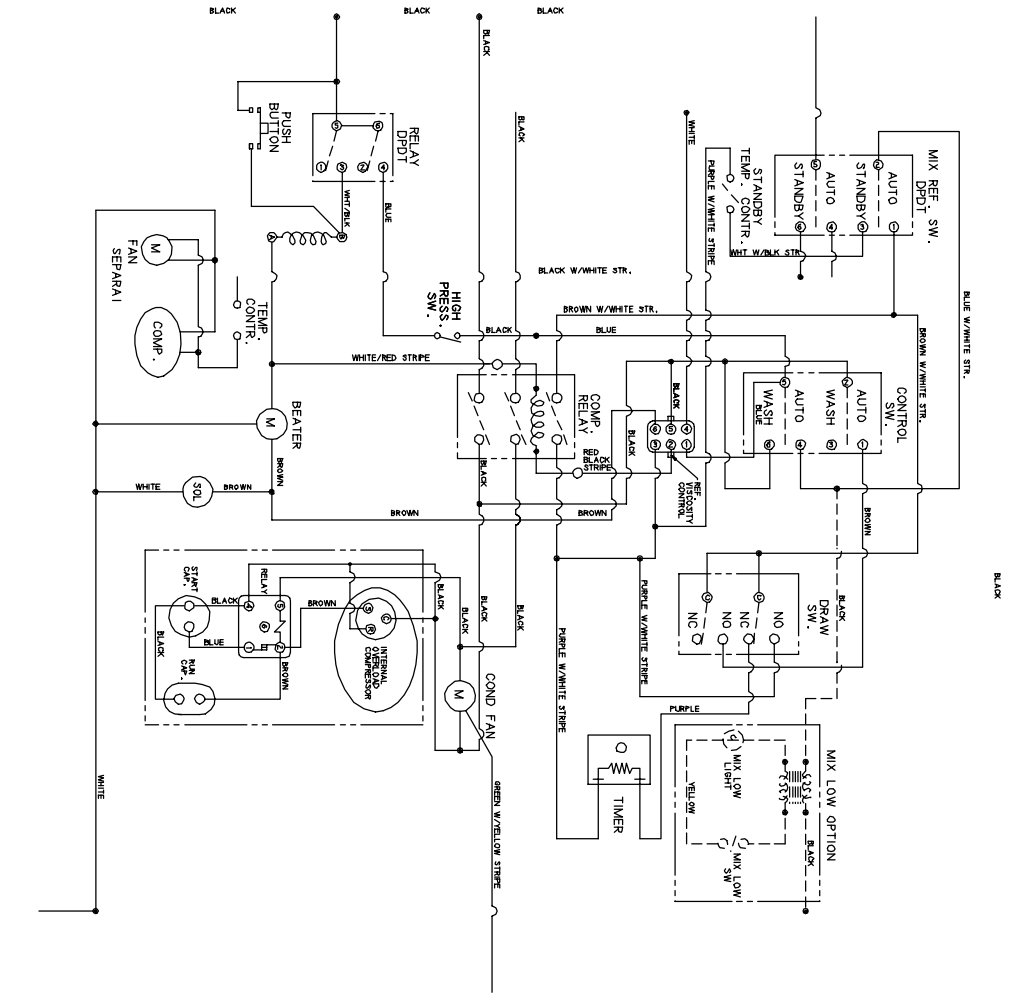

EQUIP.
GROUND

Model 152
047514

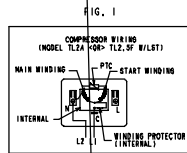

NOTES:
1. ONE (1) FAN ONLY ON MODEL 168. RUN CAPACITOR APPLIES TO MODEL 168 ONLY.

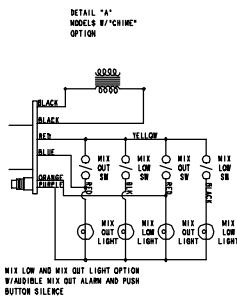
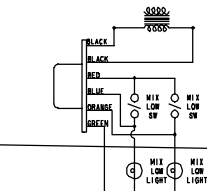
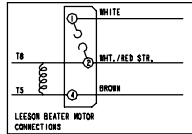

VISCOSITY CONTROL

1. LI
2. N.C. CONTACT
3. N.C. CONTACT
4. L2
5. LINE
6. LOAD

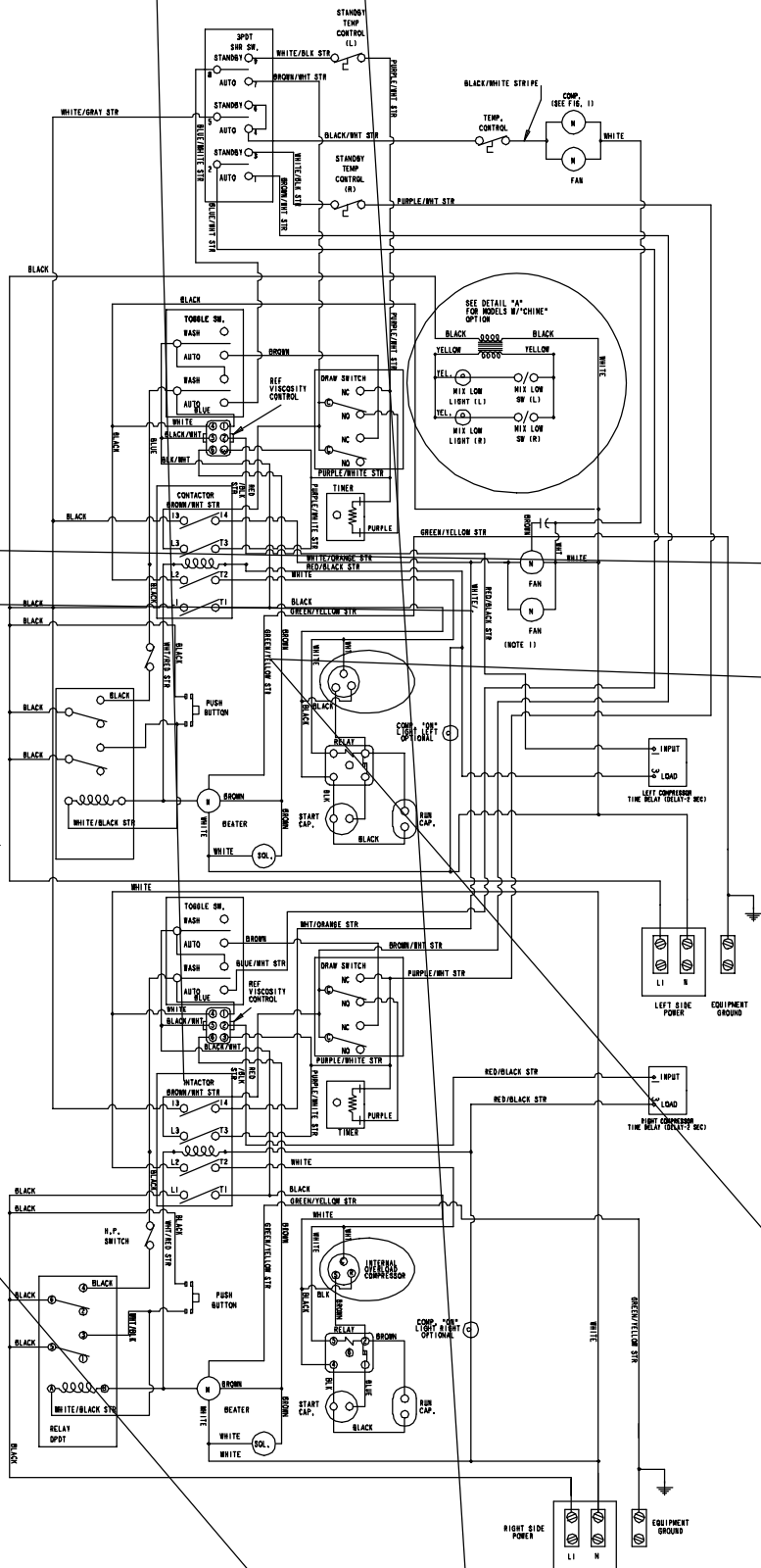
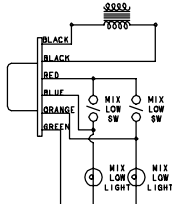
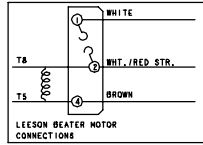
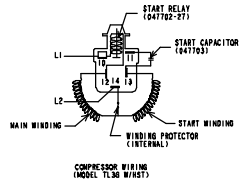
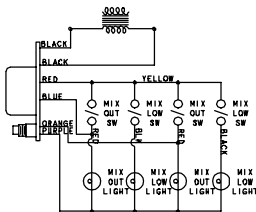

FIG. 1



DETAIL "A" MODEL W/"CHIME" OPTION



MIX LOW AND MIX OUT LIGHT OPTION W/AUDIBLE MIX OUT ALARM AND PUSH BUTTON SILENCE

VISCOUSITY CONTROL

1. L1
2. N.C. CONTACT
3. N.C. CONTACT
4. L2
5. LINE
6. LOAD

NOTES:
1. ONE (1) FAN ONLY ON MODEL 162. RUN CAPACITOR APPLIES TO MODEL 168 ONLY.

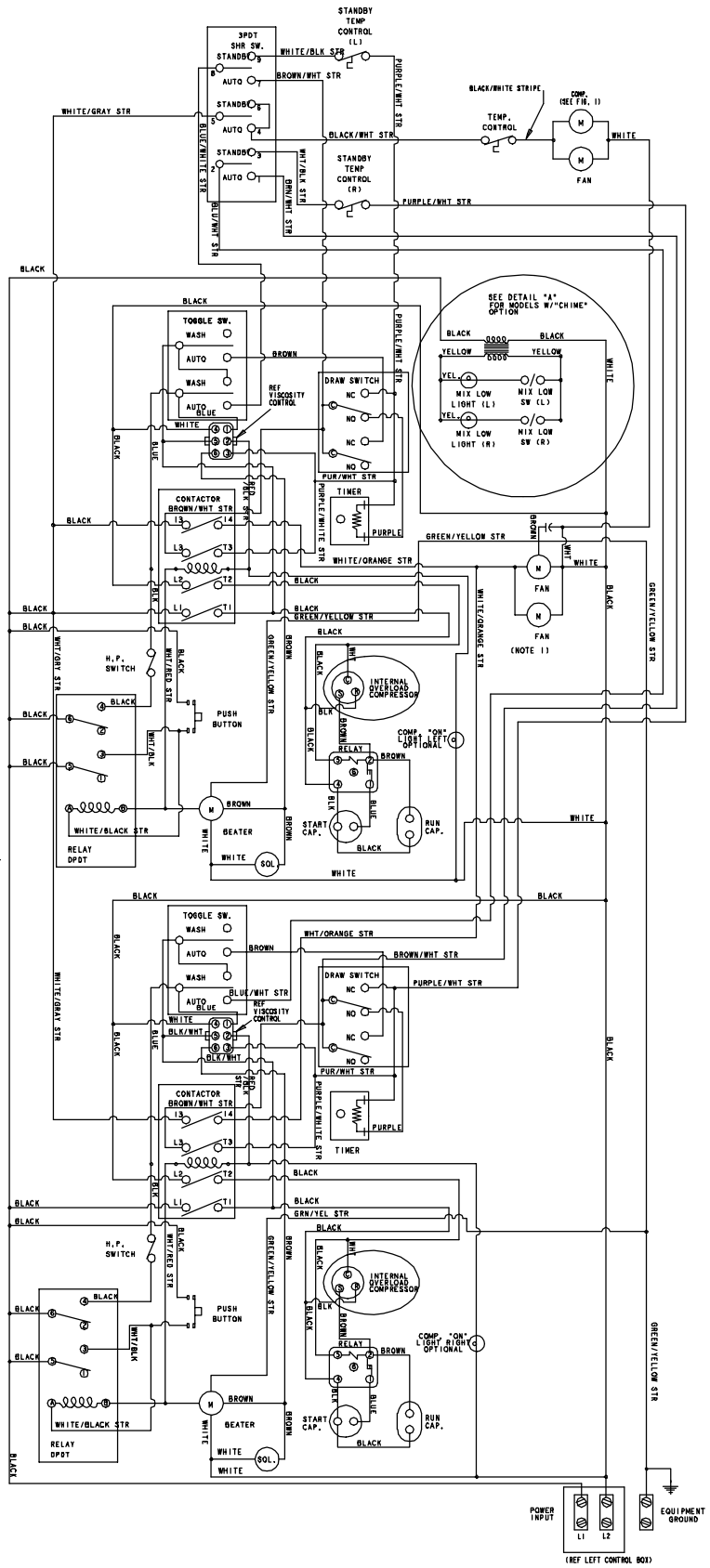

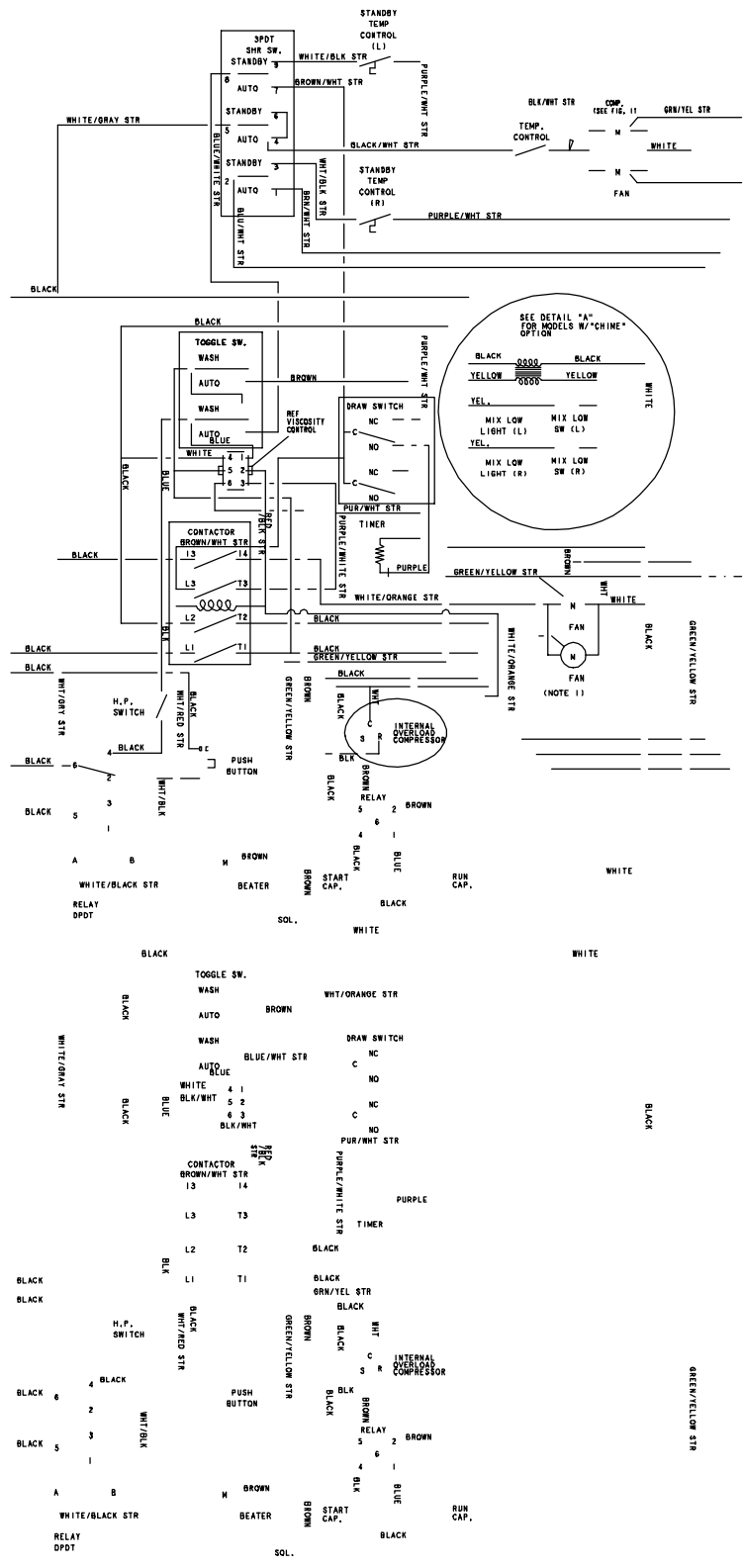

EQUIPMENT GROUND

Models 162/168
050205-40S