

Miele

Operating and installation instructions

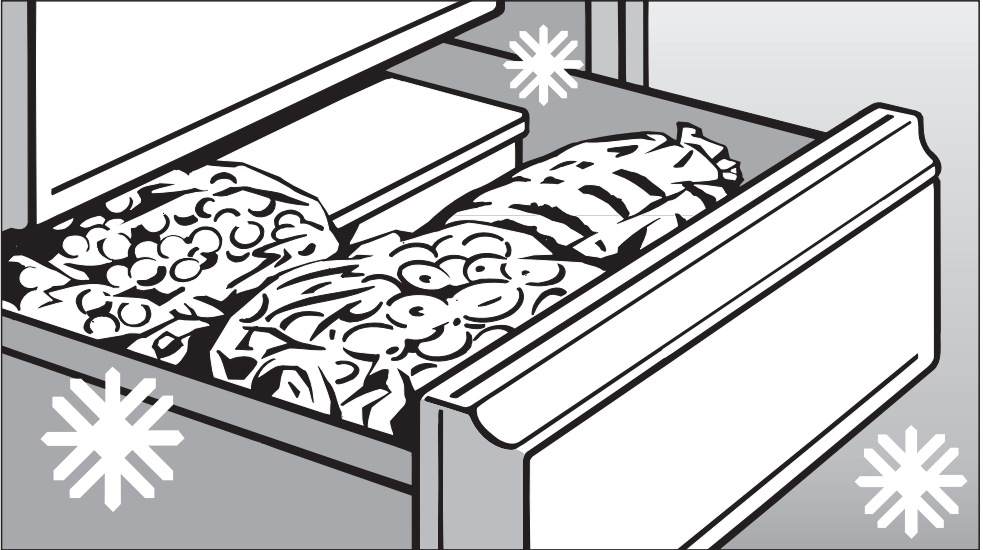

Frost-free freezer

FN 12220 S

FN 12420 S

FN 12620 S

To avoid the risk of accidents or damage to the appliance, it is **essential** to read these instructions before it is installed and used for the first time.

en - GB

M.-Nr. 07 297 850

Contents

Guide to the appliance	4
Caring for the environment	5
Warning and Safety instructions	6
How to save energy	11
Switching on and off	12
Switching off for longer periods of time	12
The correct temperature	13
Setting the temperature	13
Temperature display	14
Alarm	15
Door alarm	15
Activating the alarm system.	15
Switching the alarm off early	15
Super freeze	16
Freezing and storing food	17
Maximum freezing capacity.	17
Freezing fresh food	17
Isolation plate.	17
Important.	17
Storing frozen food	18
Home freezing	19
Hints on home freezing.	19
Packing.	19
Before placing food in the freezer	20
Placing food in the freezer	20
Freezing large items	20
Defrosting	20
Ice cubes.	21
Cooling drinks	21
Freezer tray	21
Cool pack.	22
Defrosting	23
Cleaning and care	24
Cleaning the outer casing, the interior and accessories	24
Ventilation gaps	24
Door seal	24
Metal grille at the back of the appliance	25

Contents

Problem solving guide	26
Noises	28
After Sales / Guarantee	29
Electrical connection	30
Installation	31
Location	31
Climate range	31
Ventilation	31
Installation	31
Aligning the appliance	32
Appliance dimensions	33
Changing the door hinging	34
Building in the appliance	38

Guide to the appliance

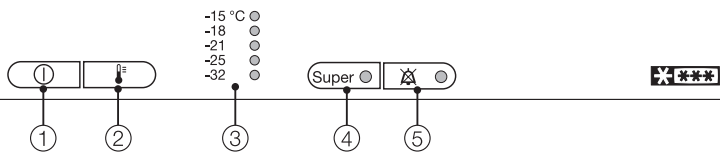

① On/Off button

② Temperature selector button

③ Temperature display

④ Super freeze button and indicator light

⑤ Alarm off button and indicator light

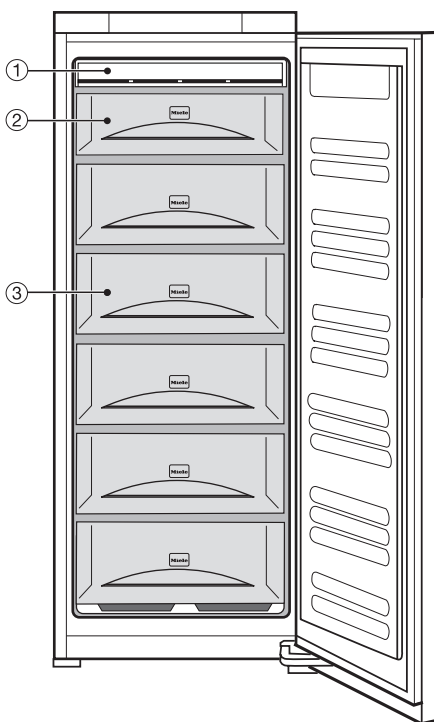

① Frost free system

② Freezer tray

③ Freezer drawers

Disposal of the packing material

The transport and protective packing has been selected from materials which are environmentally friendly for disposal, and can normally be recycled.

Ensure that any plastic wrappings, bags etc. are disposed of safely and kept out of the reach of babies and young children. Danger of suffocation!

Rather than just throwing these materials away, please ensure that they are recycled.

Disposal of your old appliance

Electrical and electronic appliances often contain materials which, if handled or disposed of incorrectly, could be potentially hazardous to human health and to the environment. They are, however, essential for the correct functioning of your appliance. Please do not therefore dispose of your old appliance with your household waste.

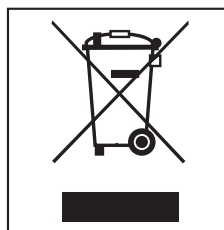

Please dispose of it at your local community waste collection / recycling centre or contact your dealer for advice. Ensure that it presents no danger to children while being stored for disposal.

It should be unplugged or disconnected from the mains electricity supply by a competent person.

Take care not to damage the pipework at the back of it before or during transportation to an authorised collection depot.

In this way, refrigerant in the pipework and oil in the compressor will be contained, and will not leak out into the environment.

Warning and Safety instructions

This appliance complies with all relevant local and national safety requirements. Improper use can, however, present a risk of both personal injury and material damage.

To avoid the risk of accidents and damage to the appliance, please read these instructions carefully before installation and before using it for the first time. They contain important notes on the installation, safety, operation and care of the appliance.

Keep these instructions in a safe place and pass them on to any future user.

Correct application

► This appliance is intended for domestic use only, to store deep frozen food, freeze fresh food, and to make ice.

Any other usage is not supported by the manufacturer and could be dangerous. The manufacturer cannot be held liable for damage resulting from incorrect or improper use or operation.

► This appliance is not intended for use by persons (including children) with reduced physical, sensory or mental capabilities, or lack of experience and knowledge, unless they are supervised whilst using it, or have been shown how to use it by a person responsible for their safety.

Safety with children

► This appliance is not a toy! To avoid the risk of injury, do not allow children to play with it or near it, or to play with the controls. Neither should they be allowed to swing on the door. Please supervise young children whilst you are using it. Older children may only use the appliance when its operation has been clearly explained to them and they are able to use it safely, recognising the dangers of misuse.

Warning and Safety instructions

Technical safety

► Before setting up the appliance, check it for any externally visible damage. Do not install and use a damaged appliance.

A damaged appliance is dangerous.

► If the connection cable is faulty it must only be replaced by a service technician authorised by the manufacturer to protect the user from danger.

► This appliance contains the coolant Isobutane (R600a), a natural gas which is environmentally friendly. Although it is flammable, it does not damage the ozone layer and does not increase the greenhouse effect. The use of this coolant has, however, led to a slight increase in the noise level of the appliance. In addition to the noise of the compressor, you might be able to hear the coolant flowing around the system. This is unavoidable, but does not have any adverse effect on the performance of the appliance.

Care must be taken during the transportation and installation of the appliance that no parts of the cooling system are damaged. Leaking coolant can damage the eyes.

In the event of any damage:

- avoid open flames and anything which creates a spark,
- disconnect from the mains,
- air the room in which the appliance is located for several minutes and
- contact the Service Department for advice.

► The more coolant there is in an appliance, the larger the room it should be installed in. In the event of a leakage, if the appliance is in a small room, there is the danger of combustible gases building up. For every 8 g of coolant at least 1 m³ of room space is required. The amount of coolant in the appliance is stated on the data plate inside the appliance.

► Safe operation of the appliance is only assured if it has been installed and connected in accordance with these operating and installation instructions.

► Before connecting the appliance, make sure that the connection data on the data plate (voltage and connected load) match the mains electricity supply.

This data must correspond in order to avoid the risk of damage to the appliance. Consult a qualified electrician if in any doubt.

► Do not connect the appliance to the mains electricity supply by a multi-socket unit or an extension lead. These do not guarantee the required safety of the appliance (e.g. danger of overheating).

Warning and Safety instructions

► The electrical safety of this appliance can only be guaranteed when continuity is complete between it and an effective earthing system which complies with current local and national safety regulations. It is most important that this basic safety requirement is present and tested regularly, and where there is any doubt, the household wiring system should be inspected by a qualified electrician. The manufacturer cannot be held liable for damage or injury caused by the lack of or inadequacy of an effective earthing system (e.g. electric shock).

► Installation, maintenance and repairs may only be carried out by a suitably qualified and competent person in strict accordance with current national and local safety regulations. Repairs and other work by unqualified persons could be dangerous. The manufacturer cannot be held liable for unauthorised work.

► While the appliance is under guarantee, repairs should only be undertaken by a service technician authorised by the manufacturer. Otherwise the guarantee will be invalidated.

► The appliance must be isolated from the electricity supply during installation, maintenance and repair work. The appliance is only completely isolated from the electricity supply when:

- it has been switched off at the socket and the plug has been withdrawn, or
- the fuse from the fused spur connection unit has been withdrawn, or
- the mains fuse has been disconnected, or
- the screw-out fuse has been removed (in countries where this is applicable).

► Faulty components must only be replaced by genuine Miele original spare parts. The manufacturer can only guarantee the safety of the appliance when Miele replacement parts are used.

► This appliance may only be used in mobile installations such as ships if a risk assessment of the installation has been carried out by a suitably qualified engineer.

► In countries where there are areas which may be subject to infestation by cockroaches or other vermin, pay particular attention to keeping the appliance and its surroundings in a clean condition at all times. Any damage which may be caused by cockroaches or other vermin will not be covered by the guarantee.

Warning and Safety instructions

Correct use

▶ Never handle frozen food with wet hands. Your hands may freeze to the frozen food. Danger of frost burn.

▶ Do not take ice cubes out with your bare hands and never place ice cubes or ice lollies in your mouth straight from the freezer.

The very low temperature of the frozen ice or lollies can cause frost burn to the lips and tongue.

▶ Do not refreeze thawed or partially thawed food.

Defrosted food should be used up as quickly as possible, as food soon loses its nutritional value and goes off.

Defrosted food may only be re-frozen after it has been cooked.

▶ Observe the "use by" dates given on food to avoid the risk of food poisoning. Storage times will depend on several factors, including the freshness and quality of the food as well as the temperature at which it is stored. Follow the instructions given on food manufacturer's packaging on storage conditions required, as well as the "use by" date.

▶ Do not store explosive materials in the appliance or any products containing propellants (e.g. spray cans). Thermostats switching on may produce sparks which could present a fire hazard. Flammable compounds could explode.

▶ Do not operate any electrical equipment (e.g. an electric ice-cream maker) inside the appliance. Danger of sparking and explosion.

▶ Do not store cans or bottles containing carbonated drinks or liquids which could freeze in the freezer. The cans or bottles could explode. Danger of injury and damage to the appliance.

▶ When cooling drinks quickly in the freezer, make sure bottles are not left in for more than one hour, otherwise they could burst, resulting in injury or damage.

▶ Do not use sharp edged objects to

- remove frost and ice,
- separate frozen foods or remove ice trays.

They will damage the evaporator, causing irreversible damage to the appliance.

▶ Do not use any oils or grease on the door seal, as these will cause the seal to deteriorate and become porous with time.

▶ Do not block the ventilation gaps in the appliance as this would impair the efficiency of the appliance, increase the electricity consumption and could cause damage to the appliance.

Warning and Safety instructions

▶ The appliance is designed for use within certain climate ranges (ambient temperatures), and should not be used outside this range. The climate range for your appliance is stated on the data plate inside the appliance.

Installing it in a room with too low an ambient temperature, e.g. a garage, can lead to the appliance switching off for longer periods so that it cannot maintain the required temperature.

▶ Do not place electric heaters or candles in the appliance to defrost it. These can damage the plastic parts.

▶ Do not use defrosting sprays or de-icers, as they might contain substances which could damage the plastic parts or which could cause a build-up of gases and pose a danger to health.

▶ Do not use a steam-cleaning appliance to defrost or clean this appliance. Steam could reach the electrical components and cause a short circuit.

Disposal of your old appliance

▶ Before disposing of an old appliance, first make the door latch or lock unusable.

This way you will prevent children from accidentally locking themselves in and endangering their lives.

▶ Be careful not to damage any part of the pipework whilst awaiting disposal, e.g. by

- puncturing the refrigerant channels in the evaporator.
- bending any pipework.
- scratching the surface coating.

Splashes of refrigerant can damage the eyes.

The manufacturer cannot be held liable for damage caused by non-compliance with these Warning and Safety instructions.

How to save energy

	Normal energy consumption	Increased energy consumption
Installation site	In a ventilated room.	In an enclosed, unventilated room.
	Protected from direct sunlight.	In direct sunlight.
	Not situated near to a heat source (radiator, oven).	Situated near to a heat source (radiator, oven).
	Where the ideal ambient room temperature is approx. 20°C.	Where there is a high ambient room temperature.
Temperature setting with a thermostat which is approximate (set in stages).	With a medium setting of 2 to 3.	With a high setting: the lower the temperature in the compartment, the higher the energy consumption.
Temperature setting with a thermostat which is exact to the degree (digital display).	Cellar section 8 to 12°C	On appliances with winter setting, please make sure that the winter setting is switched off when the ambient temperature is warmer than 16 °C.
	Refrigerator section 4 to 5 °C	
	PerfectFresh zone just above 0 °C	
	Freezer section -18°C	
	Wine storage section 10 to 12 °C	
Use	Only open the doors when necessary and for as short a time as possible.	Frequent opening of the doors for long periods will cause a loss of coldness.
	Store food in an organised way.	If food is not stored in an organised way, searching for an item will mean the door is open for longer.
	Allow hot food and drinks to cool down before placing them in the appliance.	Placing hot food in the appliance will cause the compressor to run for a long time, as the appliance will have to work harder to lower the temperature.
	Store food covered or packaged.	The evaporation or condensation of liquids will cause a loss of coldness in the refrigerator.
	Place frozen food in the refrigerator to defrost.	
	Do not over-fill the appliance to allow air to circulate.	
Defrosting	Defrost the freezer compartment when a layer of ice 0.5 cm thick has built up.	A layer of ice hinders the cold from reaching the frozen food, and causes an increase in energy consumption.

Switching on and off

Before using for the first time

- Clean the inside of the appliance and the accessories with lukewarm water and a little washing-up liquid, and then dry with a soft cloth.

Important:

To ensure the correct functioning of the appliance, let it stand for between 1½ and 2 hours after transporting it to its final location before connecting it to the mains.

Switching on

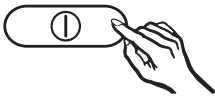

- Press the On/Off button.

The temperature display and the alarm indicator light will flash until the freezer has cooled down to the correct temperature for freezing.

To enable the temperature to get sufficiently cold inside the appliance, allow the appliance to run for a few hours before placing food in it.

Cool pack

Place the cool pack in the top drawer or, to save space, in the shallow freezer drawer. The cool pack will be at its most effective after it has been in the freezer for approx. 24 hours.

Switching off

- Press the On/Off button until the temperature display goes out.

All the displays will go out and the cooling system will switch off.

Switching off for longer periods of time

If the appliance is not going to be used for a longer period of time, e.g. whilst on holiday:

- switch the appliance off,
- switch off at the wall socket and withdraw the plug,
- clean the appliance out and
- leave the door ajar to air the appliance.

If, during a long absence, the appliance is switched off but not cleaned out and the door is left shut, there is a danger of mould and odours building up inside the appliance.

The correct temperature

It is very important to set the correct temperature for storing food in the appliance. Micro-organisms will cause food which is not stored at the correct temperature to deteriorate rapidly. Temperature influences the growth rate of these micro-organisms. Reducing the temperature reduces their growth rate.

To freeze fresh food and to store frozen food for a long time, a temperature of **-18 °C** is required. At this temperature the growth of micro-organisms is generally halted. As soon as the temperature rises above -10 °C, the micro-organisms become active in the food again so that it cannot be kept as long. For this reason, partially defrosted or defrosted food must not be re-frozen. Food may be re-frozen once it has been cooked, as the high temperatures achieved when cooking destroy most micro-organisms.

The temperature in the appliance will rise:

- the more often the door is opened and the longer it is kept open,
- if too much food is stored in it at once,
- if too much fresh food is being frozen at once,
- the higher the ambient temperature surrounding the appliance.

The appliance is designed for use in specific ambient temperatures (climate ranges). Do not use in ambient temperatures for which it is not designed.

Setting the temperature

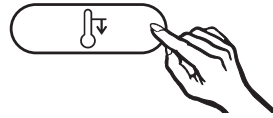

- Press the temperature button repeatedly until the indicator light for the temperature you want lights up in the display.

The temperature value will change up until the setting for -32 °C is reached. It will then drop back to the -15 °C setting.

The temperature can be set slightly colder within the displayed temperature range (e.g. between -15°C and -18 °C).

- Press the temperature button repeatedly until the indicator light for -15 °C lights up in the display.
- Press the button for approx. another 5 seconds to set the temperature.

The colder temperature setting within the small temperature range is now set. However, this is not visible in the temperature display.

The correct temperature

Temperature display

The temperature display on the control panel always shows the **required** temperature.

The temperature can be adjusted from:
-15 °C to -32 °C

The **temperature display will flash** if

- the temperature in the appliance is not within the possible temperature range,
- a different temperature is being set,
- the temperature in the appliance has risen by several degrees, indicating that the appliance is warming up too much.

This loss of coldness is no cause for concern in the following circumstances:

- when the door has been left open for a while, e.g. for removing or storing a large amount of food,
- when fresh food is being frozen.

However, if the temperature in the freezer section remains above -18 °C for a long time, check that the frozen food has not started to defrost. If it has started thawing, check that the food is safe to use and if it is, use it as quickly as possible.

Your appliance has been fitted with a warning system which ensures that the temperature in the freezer cannot rise unnoticed. An alarm will sound, and the temperature display and the alarm indicator light will flash if the temperature becomes too warm.

The temperature the appliance is set at determines the temperature the appliance recognises as being too warm.

For example, the alarm may sound and the alarm indicator light may flash,

- if you freeze a large amount of food at once without having switched on the Super freeze function beforehand.

Depending on the temperature in the freezer, you should check the condition of the food. If food has defrosted or started to defrost, check that it is still safe to use, and if so, use it as quickly as possible. Defrosted food may only be re-frozen after it has been cooked.

Door alarm

If the door has been left open for more than approx. 60 seconds the alarm will sound.

Activating the alarm system

The alarm system is always active. It does not have to be switched on manually.

Switching the alarm off early

The alarm will stop and the indicator light will go out when the temperature reaches the correct level again.

However, if the noise disturbs you, you can switch the alarm off before this if you wish.

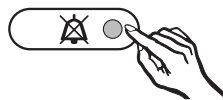

- Press the alarm off button.

The alarm will stop.

The indicator light will stay on until the correct temperature has been reached. The alarm system is then ready should it be needed again.

Super freeze

Switch the Super freeze function on before putting fresh food into the freezer.

This helps food to freeze quickly and retain its nutrients, vitamins, flavours and appearance.

Super freeze is not necessary:

- when putting in food that is already frozen.
- when freezing up to 2 kg fresh food daily.

Switching on Super freeze

When freezing small quantities of food in the freezer, the Super freeze function should be switched on **6 hours beforehand**. When freezing **the maximum load of food** the Super freeze function should be switched on **24 hours beforehand**.

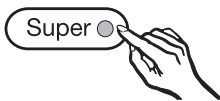

- Press the Super freeze button. The Super freeze indicator light will come on.

At the same time, the coldest temperature will light up in the temperature display.

The appliance works at full power to lower the temperature in the appliance.

Switching off Super freeze

The Super freeze function will switch off automatically after approx. 65 hours. The indicator light will go out and the appliance will run at normal power again.

The required temperature will then light up again in the temperature display.

To save energy, the Super freeze function can be switched off once a **constant** temperature of -18°C or colder has been reached in the freezer. You should also check the temperature inside the appliance from time to time.

- Press the Super freeze button. The Super freeze indicator light will go out, and the appliance will continue to operate at normal power.

Maximum freezing capacity

To ensure that fresh food placed in the freezer freezes through to the core as quickly as possible, the maximum freezing capacity must not be exceeded. The maximum freezing capacity for freezing within a 24-hour period is given on the data plate: "Freezing capacitykg/24 hrs".

The maximum freezing capacity given on the data plate has been calculated according to DIN EN ISO 15502 Standard.

Freezing fresh food

Fresh food should be frozen as quickly as possible. This way the nutritional value of the food, its vitamin content, appearance and taste are not impaired.

Food which takes a long time to freeze will lose more water from its cells, which then shrink.

During the defrosting process, only some of this water is reabsorbed by the cells; the rest collects around the food.

If food is frozen quickly, the cells have less time to lose moisture, so they shrink less. As there is not so much moisture loss, it is easier for the food to reabsorb it during the defrosting process, and very little water collects around the defrosted food.

Isolation plate

(depending on model, available as an optional accessory)

The isolation plate is used to isolate freezer drawers which you do not wish to use, and thus save energy. It should be used if only small amounts of food are being stored in the freezer.

Important

- At least 2 freezer drawers must be used for freezing food. The other drawers can be isolated if they are not needed.
- The drawers being used for freezing must always be at the top of the freezer.
- The isolation plate must be fitted **below** the lowest drawer in which food is being frozen.
- The fewer drawers you use, the more energy you will save. Using the isolation plate increases energy savings considerably.

Do not store food in the "inactive" drawers. The temperature is not controlled in these drawers and food stored in them would soon deteriorate.

Freezing and storing food

Example

If you only require 2 freezer drawers for storing frozen food:

- Place food in the top 2 freezer drawers, leaving the other drawers empty.

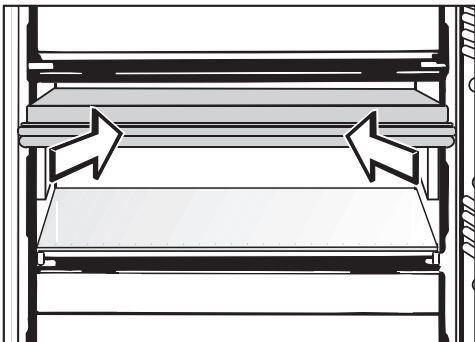

- Take out the third drawer down and push the isolation plate in **under** the second drawer.

This "switches off" (isolates) the drawers below.

Storing frozen food

When buying frozen food to store in your freezer, check

- that the packaging is not damaged,
- the use-by date,
- the temperature at which the frozen food is being stored in the shop. The length of time it can be kept is reduced if it has been stored at a temperature warmer than $-18\text{ }^{\circ}\text{C}$.

- Buy frozen food once you have finished the rest of your shopping, and wrap it in newspaper or use a cool bag or cool box to transport it.
- Store it in the freezer as soon as possible.

Never re-freeze partially or fully defrosted food. Consume defrosted food as soon as possible as it will lose its nutritional value and spoil if left for too long. Defrosted food may only be re-frozen after it has been cooked.

Home freezing

Only freeze fresh food which is in a good condition.

Hints on home freezing

- The following types of food **are suitable** for freezing:
Fresh meat, poultry, game, fish, vegetables, herbs, fresh fruit, dairy products, pastry, leftovers, egg yolks, egg whites and a range of pre-cooked meals.
- The following types of food **are not suitable** for freezing:
Grapes, lettuce, radishes, sour cream, mayonnaise, eggs in their shells, onions, whole raw apples and pears.
- To retain colour, taste and vitamin C, vegetables should be blanched after they have been trimmed and washed.
To blanch: bring a large saucepan of water to the boil, immerse the vegetables in the fast boiling water for 2-3 minutes, depending on variety. Remove, and plunge into ice-cold water to cool quickly. Drain and pack ready for freezing.
- Lean meat freezes better than fatty meat, and can be stored for considerably longer.
- To prevent chops, steaks, cutlets or rolled meat from freezing together in solid blocks when packed, separate with a sheet of plastic freezer film.
- Do not season fresh foods or blanched vegetables before freezing. Only season cooked food

lightly before freezing, but care should be taken as the taste of some spices alters when frozen.

- Do not place hot foods or drinks in the freezer. This causes already frozen food to thaw, and increases the energy consumption considerably. Allow hot foods and drinks to cool down before placing them in the freezer.

Packing

- Freeze food in portions.

Unsuitable packing material

- wrapping paper
- grease-proof paper
- cellophane
- bin bags
- plastic carrier bags

Suitable packing material

- plastic freezer film
- freezer bags
- aluminium foil
- freezer containers

- Expel as much air as possible from bags etc. before sealing them, to prevent freezer-burn on food.
- Close the packaging tightly with
 - rubber bands
 - plastic clips
 - string or bag ties
 - freezer tape.

Freezer bags may also be sealed using home heat sealing kits.

- Make a note of the contents and the date of freezing on the packaging.

Freezing and storing food

Before placing food in the freezer

- When freezing more than 2 kg of fresh food, switch on the Super freeze function for some time before placing the food in the freezer (see "Super freeze").

This helps food that is already in the freezer to stay frozen.

Placing food in the freezer

Fresh food can be placed in any drawer for freezing, however it is preferable to use the upper drawers.

- Place the food flat in the bottom of the drawers or on the glass cold plates so that it freezes through to the core as quickly as possible.
- Make sure that the packaging and containers are dry to prevent them sticking together when frozen.

When freezing, make sure that food already frozen does not come into contact with fresh food being frozen as this could cause the frozen food to begin to defrost.

Freezing large items

If you wish to freeze large items such as a turkey or game, the glass cold plates between the drawers can be removed. To do this:

- Remove the freezer drawers and carefully slide out the glass cold plates.

The lowest freezer drawer must always remain in the appliance.

Each drawer and glass cold plate can be loaded with a maximum of 25 kg.

If you remove a freezer drawer make sure that you do not block the ventilation slits in the back wall of the appliance. They are important for trouble-free operation of the appliance.

Defrosting

Frozen food can be defrosted in different ways:

- in a microwave oven,
- in an oven using the "Fan" or "Defrost" setting,
- at room temperature,
- in the refrigerator (the cold given off by the frozen food helps to keep other food cold),
- in a steam oven.

Poultry It is particularly important to observe food hygiene rules when defrosting poultry. Do not use the liquid from defrosted poultry. Pour it away and wash the container it was in, the sink and your hands. Danger of salmonella poisoning.

Fruit should be defrosted at room temperature in its packaging, or in a covered bowl.

Most vegetables can be cooked while still frozen. Just put straight into boiling water or hot fat. The cooking time is slightly less than that of fresh vegetables due to changes in the cell structure.

Freezing and storing food

Never re-freeze partially or fully defrosted food. Consume defrosted food as soon as possible as it will lose its nutritional value and spoil if left for too long. Defrosted food may only be re-frozen after it has been cooked.

Ice cubes

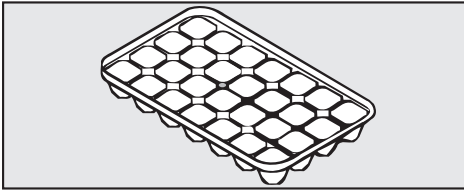

- Fill the ice tray three quarters full with water and place it on the bottom of one of the freezer drawers.
- Once frozen, use a blunt instrument, for example a spoon handle, to remove the ice tray from the freezer.
- Ice cubes can be removed easily from the tray by twisting the tray gently or by holding it under cold running water for a short while.

Cooling drinks

When cooling drinks quickly, make sure bottles are **not left in the freezer for more than one hour**, as they could burst.

Freezer tray

The freezer tray is useful for freezing small items such as berries and vegetables. They can be frozen individually and therefore maintain their shape when defrosted.

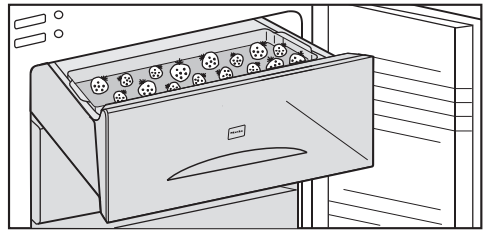

- Space the food out loosely on the tray.
- Leave the food for 10-12 hours to freeze thoroughly on the tray. Transfer it to a freezer bag or suitable container once frozen. Place the bag or container in the freezer drawer.

Freezing and storing food

Cool pack

The cool pack prevents the temperature in the freezer rising too quickly in the event of a power cut.

Place the cool pack in the upper drawer directly on top of food, or in the freezer tray to save space. The cool pack will be at its most effective after it has been in the freezer for approx. 24 hours.

If there is a power cut, place the cool pack directly on top of the frozen food in the top drawer so that the food will be kept cold for as long as possible.

When placing fresh food in the freezer, use the cool pack to separate the fresh food from the food which is already frozen so that the frozen food does not begin to thaw.

The cool pack can also be used in a cool bag to keep food or drinks cool for a short period of time.

This freezer is equipped with a Frost free system. The freezer defrosts automatically.

The moisture generated by defrosting collects in the condensor and is automatically dissipated by the condensor from time to time.

This automatic defrosting system enables the freezer to remain permanently ice-free, however, the food stored in the freezer will not defrost.

Cleaning and care

A range of Miele cleaning and conditioning agents is available from the Miele UK Spare Parts Department or via the internet at www.miele-shop.com.

Never use cleaning agents containing abrasive substances such as sand, soda, acids or chemical solvents. "Non-abrasive" cleaning agents are also unsuitable as they can cause matt areas to appear.

Make sure that water cannot get into the electronic unit or into the ventilation gaps.

Do not use steam cleaning apparatus to clean the appliance. Steam could reach the electrical components and cause a short circuit.

The data plate located inside the appliance must not be removed. It contains information which is required in the event of a service call.

Before cleaning

- Switch the appliance off, switch off at the socket and remove the plug.
- Take any frozen food out of the appliance and store it in a cool place.
- Take the freezer drawers and the glass cold plates out of the freezer to clean them.

Cleaning the outer casing, the interior and accessories

Use warm water with a little washing-up liquid. Wash all accessories and drawers by hand only. Do not wash in a dishwasher.

- After cleaning, wipe the outer casing, the interior and accessories with a damp cloth and dry with a soft cloth. Leave the door open to air the appliance for a short while.

Ventilation gaps

- The ventilation gaps should be cleaned regularly with a brush or vacuum cleaner. A build-up of dust will increase the energy consumption of the appliance.

Door seal

Do not use any oils or grease on the door seal. These will cause the seal to deteriorate and become porous over time.

The door seal should be cleaned regularly with clean water and then wiped dry with a soft cloth.

Metal grille at the back of the appliance

The metal grille at the back of the appliance (heat exchanger) should be dusted at least once a year. A build-up of dust will increase the energy consumption of the appliance.

When cleaning the grille, make sure that the pipework and other components do not get broken or damaged in any way.

After cleaning

- Close the appliance door, insert the plug in the socket and switch the appliance back on.
- Switch on the Super freeze function so that the freezer can cool down quickly.
- Once the temperature in the freezer has reached the required temperature, place the food back in the freezer drawers and put them back in the freezer.
- Switch off the Super freeze function as soon as the temperature in the freezer is a constant $-18\text{ }^{\circ}\text{C}$ or colder.

Problem solving guide

Repairs to electrical appliances should only be carried out by a suitably qualified and competent person in strict accordance with current local and national safety regulations. Repairs and other work by unqualified persons could be dangerous. The manufacturer cannot be held liable for unauthorised work.

Some minor problems can be corrected without contacting Miele.

What to do if . . .

. . . the appliance does not get cool.

- Check whether the appliance has been switched on. The temperature display must be lit up.
- Check that the plug is correctly inserted into the socket and switched on.
- Check that the fuse is not defective and that the mains fuse has not tripped. If it has, contact the Miele Service Department.

. . . the door will not open because it has been opened and closed too many times in succession.

This is not a fault. The suction caused by opening and closing the door is preventing the door from opening. Wait a few minutes and then try again. It should now open without force.

. . . the temperature inside the appliance is too low.

- Turn the temperature to a higher setting.
- Super freeze has not yet switched itself off. The Super freeze function switches itself off automatically after approx. 65 hours.

. . . the appliance is switching in too frequently and for too long.

- Check whether the ventilation gaps have been covered over or become dusty.
- Check whether the metal grille (heat exchanger) at the back of the appliance has become too dusty.
- The door has been opened too frequently, or a large amount of fresh food has been put in at once for freezing.
- Check that the door has been closed properly.

. . . the compressor runs continuously.

To save energy, the compressor runs at a lower speed, but for longer, when less cooling is required.

. . . the alarm sounds and the alarm indicator light flashes.

The temperature in the freezer is too warm, because

- a large amount of food has been frozen at once without switching on the Super freeze function.
The alarm will stop and the indicator light will go out when the temperature has reached the correct level again.
- the compressor is faulty. Call the Service Department.

Depending on the temperature in the freezer, you should check the condition of the food. If food has defrosted or started to defrost, check that it is still safe to use, and if so, use it as quickly as possible. Defrosted food may only be re-frozen after it has been cooked.

. . . the Super freeze indicator light and the temperature display are both flashing at the same time.

There is a fault. Call the Service Department.

. . . the Super freeze indicator light does not light up, even though the appliance is working.

- The indicator light is defective. Call the Service Department.

. . . food has frozen together.

Use a blunt instrument, e.g. a spoon handle or plastic scraper, to prise it apart carefully.

If you still cannot remedy the fault having followed these suggestions, please contact the Miele Service Department.

To prevent unnecessary loss of temperature it is advisable not to open the door while waiting for the appliance to be serviced.

Noises

Normal noises	What causes them
Brrrrr...	Humming noise made by the motor (compressor). This noise can get louder for brief periods when the motor is switching on.
Blubb, blubb....	A gurgling noise can be heard when coolant is circulating through the pipes.
Click....	Clicking sounds are made when the thermostat switches the motor on and off.
Sssrrrrr....	On multi-zone and frost-free appliances you can sometimes just hear the movement of air circulating inside the appliance.

Remember that the noise of the compressor and the coolant circulating in the system is unavoidable.

Noises that you can easily rectify	What causes them, and what can you do about them?
Rattling, vibrating	The appliance is uneven: Realign the appliance using a spirit level, by raising or lowering the screw feet underneath the appliance.
	The appliance is touching another appliance or piece of furniture: Move it away.
	Drawers, baskets or shelves are unstable or sticking: Check all removable items and refit them correctly.
	Are any bottles or containers unstable or knocking against each other? Separate them.
	The transport cable clips are hanging loose at the back of the appliance: Remove the clips.

In the event of a fault which you cannot correct yourself, or if the appliance is under guarantee, please contact:

- your Miele Dealer or Chartered Agent
- or
- the Miele Service Department
(see back cover for contact details).

When contacting your Dealer/Chartered Agent or Miele, please quote the model and serial number of your appliance. This information is given on the data plate inside your appliance.

Please note that telephone calls may be monitored and recorded for training purposes.

Guarantee

For information on the appliance guarantee specific to your country please contact Miele. See back cover for contact details.

In the U.K. your appliance is guaranteed for 2 years from the date of delivery. However, you must activate your cover by calling 08706 080028 or registering online at www.miele.co.uk.

Electrical connection

Electrical connection U.K.

All electrical work should be carried out by a suitably qualified and competent person in strict accordance with current local and national safety regulations (BS 7671 in the UK).

The appliance is supplied with a mains cable and moulded plug ready for connection to an a.c. single phase 220-240 V 50 Hz supply.

Please ensure that the connection data quoted on the data plate match the household mains supply.

Connection should be made via a suitable switched socket which is easily accessible. For extra safety it is advisable to install a suitable residual current device (RCD).

Do not connect the appliance to the mains electricity supply by an extension lead. Extension leads do not guarantee the required safety of the appliance (e.g. danger of overheating).

The appliance must not be connected to an inverter and must not be used with a plug adapter as these can cause damage to the appliance's electronic unit.

Non-rewireable plugs (BS 1363)

The fuse cover must be re-fitted when changing the fuse, and if the fuse cover is lost, the plug must not be used until a suitable replacement is obtained. The colour of the correct replacement cover is that of the coloured insert in the base of the plug, or the colour that is embossed in words in the base of the plug (as applicable to the design of the plug fitted).

Replacement fuses should be ASTA approved to BS 1362 and have the correct rating. Replacement fuses and fuse covers may be purchased from your local electrical supplier.

WARNING
THIS APPLIANCE MUST BE
EARTHED

Do not place any appliance which gives off heat, such as a toaster or microwave oven, on top of this appliance, as this would increase the appliance's energy consumption.

This appliance must not be installed directly next to another refrigerator or freezer. It does not have side-wall heating, so installation next to another refrigerator or freezer could cause a build-up of condensation between them. Further information is available from your dealer.

Location

This appliance should be installed in a dry, well-ventilated room. It should not be installed where it is exposed to direct sunlight or directly adjacent to a heat-producing appliance such as an oven or a radiator. The room temperature should not go above or below the climate range for which the appliance is designed. The higher the ambient temperature of the room, the more energy the appliance requires to operate.

Climate range

The appliance is designed for use within certain climate ranges (ambient temperatures), and should not be used outside this range. The climate range of the appliance is stated on the data plate inside the appliance.

Climate range	Ambient room temperature
SN	+10°C to +32°C
N	+16°C to +32°C
ST	+16°C to +38°C
T	+16°C to +43°C
SN-ST	+10°C to +38°C
SN-T	+10°C to +43°C

The appliance will function perfectly down to an ambient temperature of +5 °C.

Ventilation

Air at the back of the appliance gets warm. To ensure sufficient ventilation, the ventilation gaps must not be covered over. The air inlet and outlet must not be covered or blocked in any way. They should be dusted on a regular basis.

Installation

- Remove the cable clip from the back of the appliance.
- Check that all parts at the back of the appliance are unhindered. Carefully remove any hindrance.
- Carefully push the appliance into position
- with the back against the wall.

Installation

Aligning the appliance

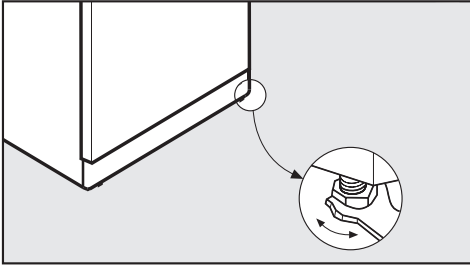

- To align the appliance adjust the feet using the spanner supplied.

Appliance dimensions

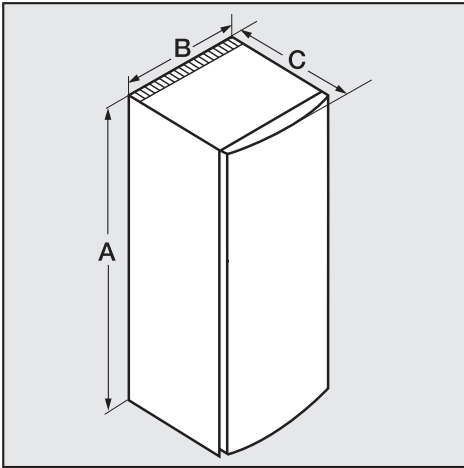

	A	B	C
FN 12220 S	1250 mm	600 mm	630 mm
FN 12420 S	1447 mm	600 mm	630 mm
FN 12620 S	1644 mm	600 mm	630 mm

Changing the door hinging

The appliance is supplied right-hand hinged. If left-hand door hinging is required, follow the instructions below.

To change the door hinging you will need the following tools:

- a cross-slotted screwdriver,
- a flat-bladed screwdriver,
- a selection of Torx screwdrivers,
- a spanner.

Two people are needed for changing the door hinging.

Removing the door handle:

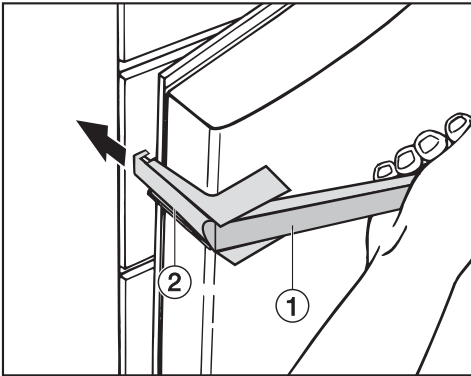

- Pull door handle ① towards you. Side section ② slides back.
- Pull side section ② out of the guides on the mounting plate.
- Loosen the 4 screws (Torx 15) in the mounting plate, and remove the handle.
- Remove the cover caps from the opposite side, and fit them into the empty holes.

Changing the door hinging

Changing over the door:

- Open the appliance door.

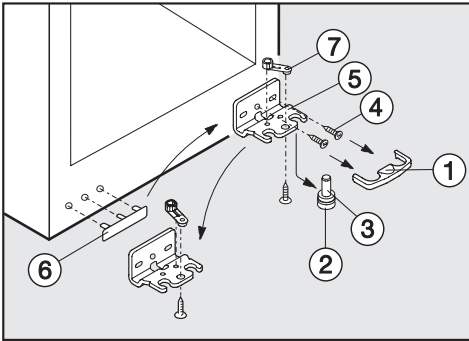

- Remove cover ① by pulling it forwards.
- With the help of a second person, carefully tilt the appliance backwards and pull hinge pin ② out.
- Do not lose hinge bush ③.

Warning. The appliance door is no longer secure.

- Open the door, and pull it downwards and off.
- Loosen screws ④ and take hinge plate ⑤ off.
- Remove cover ⑥ and fit it into the holes on the opposite side.
- Unscrew bearing ⑦ from hinge plate ⑤ and screw it into the hole on the other side of hinge plate ⑤.

- Screw hinge plate ⑤ into position on the opposite side, using the outside holes (use the long and the round holes).

If necessary, the second long hole can be used instead of the round hole for securing the hinge plate, e. g. when aligning with uneven flooring.

Changing the door hinging

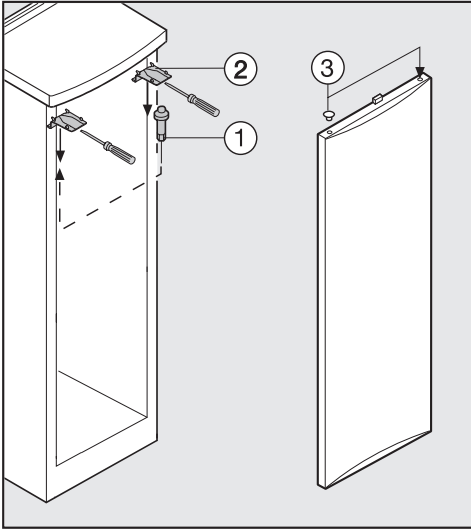

- Unscrew upper hinge pin ① using the spanner supplied and refit on the opposite side.
- Using a screwdriver remove covers ②.
- Refit covers ② from the back on the opposite side, and then click them into place at the front
- Remove cap ③ from door bearing bush in the door and refit on the opposite side.
- Hang the door on hinge pin ① and then close the appliance door.

In the following illustration the door is not shown in the closed position to make it easier to see what happens next.

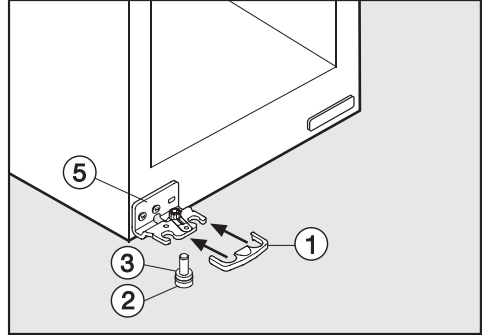

- Using a second person carefully tip the appliance back and then fit hinge pin ② together with hinge bush ③ from below into hinge plate ⑤ on the left hand side.
- Align the door with the appliance housing using the long slot in hinge plate ⑤. Then tighten the screws.
- Refit cover ① on the left-hand side.

Changing the door hinging

Refitting the handle:

Please make sure you follow the instructions below carefully when you refit the handle. The door seal will be damaged if the handle is fitted incorrectly.

It is important to check that the side section of the handle ④ does not come into contact with the door seal when opening the door, as this would damage the door seal permanently.

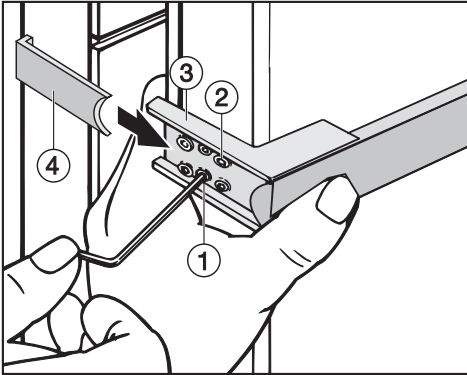

If, after you have refitted the handle, you find that the side section does touch the door seal when the door is opened:

- Realign mounting plate ③ with grub screws ① until the mounting plate and the side section of the handle ④ are at the correct angle and the side section does not touch the door seal when the door is opened.

- Loosely attach the handle to the opposite side of the door with the two front screws ②.

Mounting plate ③ must be positioned on the side of the door so that when the door is **closed** it is flush with the side of the appliance.

If this is not the case,

- tighten both grub screws ① with an allen key until mounting plate ③ lines up correctly.
- Then tighten all 4 fixing screws ②.
- Slide the side section of the handle ④ into the guides on the mounting plate until it clicks into place.

Building in the appliance

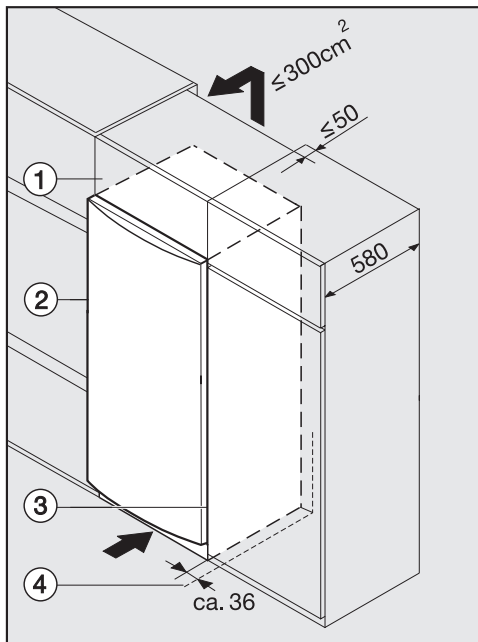

The air inlet and outlet must not be covered or blocked in any way. They should be dusted on a regular basis.

When built into a kitchen run (max. depth 580 mm) the appliance can be installed directly next to a kitchen furniture housing unit. The appliance door will protrude in front of furniture fronts at the sides by 34 mm and by 50 mm in the middle of the door. This enables the doors to be opened and shut without being obstructed.

When **installed next to a wall** (4) a distance of approx. 36 mm is needed on the hinge side between the wall (4) and the appliance (2), so that the doors and handles have sufficient space for opening.

- ① Top box
- ② Appliance
- ③ Housing unit
- ④ Wall

The appliance can be installed in a kitchen run. To match the height of the rest of the kitchen, the appliance can be fitted with a suitable top box (1).

A ventilation gap of at least 50 mm depth must be allowed for behind the appliance across the entire width of the top box for air to circulate.

The cross section of the air outlet under the room ceiling must be at least 300 cm² to ensure that air can circulate without hindrance. Otherwise the appliance has to work harder, resulting in an increase in electricity consumption.



United Kingdom

Miele Co. Ltd.
Fairacres, Marcham Road
Abingdon, Oxon, OX14 1TW
Tel: (01235) 554455
Fax: (01235) 554477
Customer Contact Centre Tel: (08707) 554466
E-mail: info@miele.co.uk
Internet: www.miele.co.uk

Australia

Miele Australia Pty. Ltd.
A.C.N. 005635398
1 Gilbert Park Drive, Knoxfield, VIC 3180
Tel: (03) 9764 7130
Fax: (03) 9764 7149
Internet: www.miele.com.au

China

Miele Shanghai Rep. Office
Room 4105 - 6, 41 Floor
Plaza 66, 1266 Nan-Jing Road/ West
Shanghai 200040
Tel: +86 21 6288 4200
Fax: +86 21 6288 4100
E-mail: mieleshanghai@cn.miele.com
Internet: www.miele.cn

Hong Kong

Miele (Hong Kong) Limited
AIA Plaza, 24 Floor
18 Hysan Avenue
Causeway Bay
Tel: +852- 2610-1331
Fax: +852-2610-1013
E-mail: mielehk@miele.com.hk
Internet: www.miele.hk

Ireland

Miele Ireland Ltd.
Broomhill Road, Tallaght, Dublin 24
Tel: (01) 461 0710
Fax: (01) 461 07 97
E-Mail: info@miele.ie
Internet: www.miele.ie

New Zealand

Miele New Zealand Limited
Unit L, 10-20 Sylvia Park Road
Mt. Wellington, 1060, Auckland, NZ
Tel: 0800 264353
Fax: 0800 463453
Internet: www.miele.co.nz

South Africa

Miele (Pty) Ltd
63 Peter Place, Bryanston 2194
P.O. Box 69434, Bryanston 2021
Tel: +27 (0) 11 548-1900
Fax: +27 (0) 11 548-1935
E-mail: info@miele.co.za
Internet: www.miele.co.za

Singapore

Miele Southeast Asia
Miele Pte. Ltd.
163 Penang Road
04 - 02/03 Winsland House II
Singapore 238463
Tel: +65 6735 1191
Fax: +65 6735 1161
E-Mail: infosea@miele.com.sg
Internet: www.miele.sg

United Arab Emirates

Miele Appliances Ltd.
P.O. Box 11 47 82
Gold & Diamond Park
Sheikh Zayed Road
Building 6 / Offices Nos. 6-214 to 6-220
Dubai
Tel: +971-4-341 84 44
Fax: +971-4-341 88 52
E-Mail: info@miele.ae
Internet: www.miele.ae