

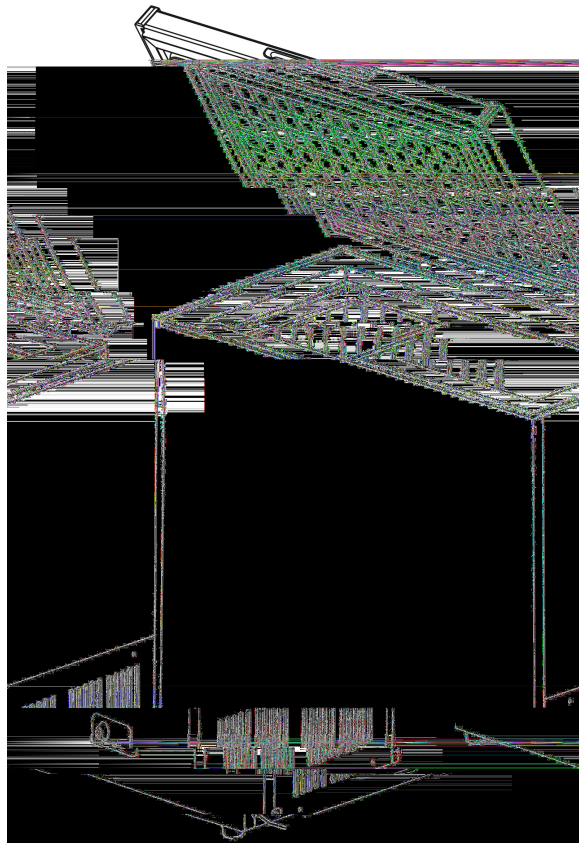

Magic Chef™
SO RIGHT AT HOME.™

**CHEST FREEZER
INSTRUCTION MANUAL**

**Model No.: MCCF5WBX
MCCF7WBX**



To ensure proper use of this appliance and your safety, please read the following instructions completely before operating this appliance.

TABLE OF CONTENTS

NAMES OF THE PARTS.....	2
SPECIFICATIONS.....	3
IMPORTANT SAFETY INSTRUCTIONS.....	4
INSTALLATION INSTRUCTIONS	
BEFORE USING YOUR FREEZER.....	4
INSTALLING YOUR FREEZER	4
ELECTRICAL CONNECTION.....	5
OPERATING YOUR FREEZER	
TEMPERATURE CONTROL.....	5 - 6
DEFROSTING YOUR FREEZER.....	6
THE FREEZER COMPARTMENT.....	6 - 7
CARE AND MAINTENANCE	
CLEANING YOUR FREEZER.....	7
VACATION TIME.....	7
MOVING YOUR FREEZER.....	7
ENERGY SAVING TIPS.....	7
TROUBLESHOOTING GUIDE.....	8 - 9
CHEST FREEZER WARRANTY.....	10

NAMES OF THE PARTS

MODEL NO. MCCF5WBX / MCCF7WBX

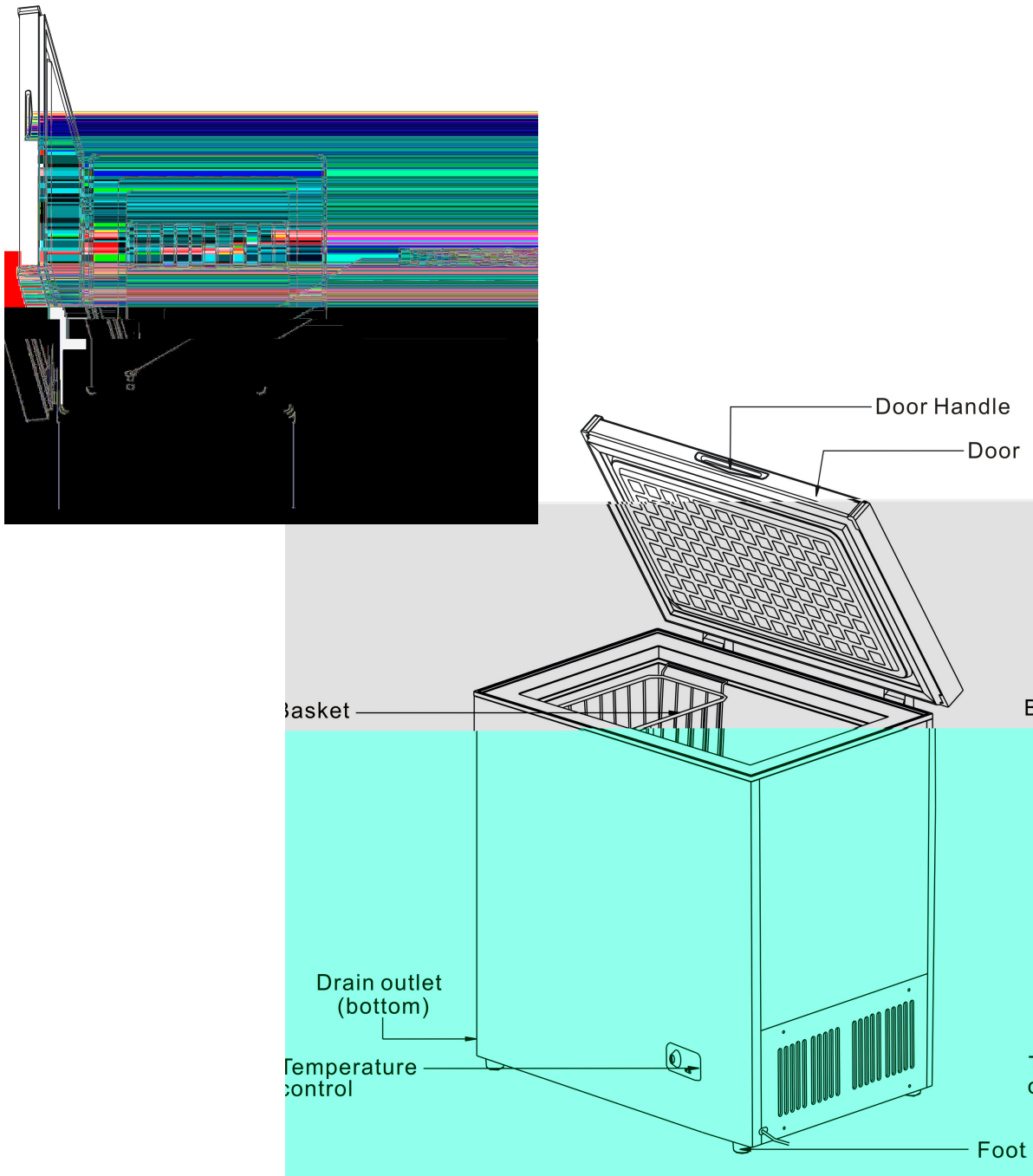

⚡ WARNING ⚡ : Never touch the interior of the Freezer Chamber or frozen foods in the compartment with wet hands as this could result in frost bite.

SPECIFICATIONS – Model # MCCF7WBX

Product Description	Magic Chef Chest Freezer		
Model No.	MCCF7WBX		
Capacity	7.2 Cu. Ft.		
Unit Dimensions (inches)	Width	Height	Depth
	34.0"	34.0"	24.0"
Net Weight (lbs)	97 (lbs)		

SPECIFICATIONS – Model # MCCF5WBX

Product Description	Magic Chef Chest Freezer		
Model No.	MCCF5WBX		
Capacity	5.5 Cu. Ft.		
Unit Dimensions (inches)	Width	Height	Depth
	27.5"	34.0"	24.0"
Net Weight (lbs)	88 (lbs)		

IMPORTANT SAFETY INSTRUCTIONS

⚡ WARNING ⚡	To reduce the risk of fire, electrical shock, or injury when using your freezer, follow these basic precautions:
<ul style="list-style-type: none">• Read all instructions before using the freezer.• DANGER or WARNING: Risk of child entrapment.• To avoid the possibility of child entrapment, please take the following precautions: Remove the freezer top and DO NOT remove the internal basket.• Before you throw away your old freezer: Take off the top. Leave the basket in place so that children may not easily climb inside.• Never allow children to operate, play with, or crawl inside the freezer.• Never clean freezer parts with flammable fluids. The fumes can create a fire hazard or explosion.• Do not store or use gasoline or any other flammable vapors and liquids in the vicinity of this or any other freezer. The fumes can create a fire hazard or an explosion.• Never open the grill unless you are a professional. <p style="text-align: center;">-Save these instructions-</p>	

INSTALLATION INSTRUCTIONS

Before Using Your Freezer

- Remove the exterior and interior packing.
- Check to be sure you have all of the following parts:
 - 1 Storage Basket
 - 1 Divider
 - 1 Instruction Manual
- Before connecting the freezer to the power source, let it stand upright for approximately 4 hours. This will reduce the possibility of a malfunction in the cooling system from improper handling during transportation.
- Clean the interior surface with lukewarm water using a soft cloth. (Cleaning instruction on page 7)

Installing Your Freezer

- This appliance is designed to be free standing only, and should not be recessed or built-in.
- Place your freezer on a floor that is strong enough to support the freezer when it is fully loaded.
- Allow 5 inches of space between the back and sides of the freezer, which allows the proper air ventilation. Adjust the feet to keep the freezer level.
- Locate the freezer away from direct sunlight and sources of heat (stove, heater, radiator, etc.). Direct sunlight may affect the acrylic coating and heat sources may increase electrical consumption. Ambient temperature below 50°F or above 85°F will hinder the performance of this appliance. **This unit is not designed for use in a garage or any other outside installation.**
- Avoid locating the freezer in moist areas.
- Plug the freezer into dedicated, properly installed-grounded wall outlet. Do not under any circumstances cut or remove the third (ground) prong from the power cord. Any questions concerning power and/or grounding should be directed toward a certified electrician or an authorized service center. **This unit is not designed to be installed in an RV or used with an inverter.**
- After plugging the appliance into a wall outlet, turn the unit on and allow the unit to cool down for 2~3 hours under before placing food in the freezer compartment.

Electrical Connection

⚡WARNING⚡

Improper use of the grounded plug can result in the risk of electrical shock. If the power cord is damaged, have it replaced by an authorized service center.

This freezer should be properly grounded for your safety. The power cord of this freezer is equipped with a three-prong plug which mates with standard three prong wall outlets to minimize the possibility of electrical shock.

Do not, under any circumstances, cut or remove the third ground prong from the power cord supplied.

This freezer requires a standard 115/120 Volt A.C. ~/60Hz electrical outlet with three-prong ground.

This freezer is not designed to be used with an inverter.

The cord should be secured behind the freezer and not left exposed or dangling to prevent accidental injury.

Never unplug the freezer by pulling the power cord. Always grip the plug firmly and pull straight out from the receptacle.

Do not use an extension cord with this appliance. If the power cord is too short, have a qualified electrician or service technician install an outlet near the appliance. Use of an extension cord can negatively effect the performance of the unit.

The "POWER" light (Green) indicates that the freezer is properly connected to the electrical power.

The "RUN" light (Red) will not illuminate when the unit is operating below freezing.

The "RUN" light will illuminate when the temperature inside the unit increases above freezing. Please be advised that the "RUN" light may come on for a period of time when the lid is opened, when new items are stored inside the unit or when the lid is forced open by irregular contents.

Do not call for service unless the "RUN" light has remained on for 6 hours or more. If this light stays on continuously for a period of 6 hours, please contact our Customer Service Dept. to consult with a representative at 888 775-0202 or visit our website to request warranty service at www.magicchef-ewave.com.

OPERATING YOUR FREEZER

Temperature Control

- Your freezer has one control for regulating the temperature. The temperature control is located on the lower right hand corner.
- The first time you turn the unit on, adjust the temperature control knob to "3" and run for at least 2 hours before putting frozen foods inside. This will ensure the cabinet is thoroughly chilled before food is put in.
- The range of the FREEZER temperature control is from position "1" the warmest to "5" the coldest. Adjust the temperature control to the setting that best suits your needs. The setting of

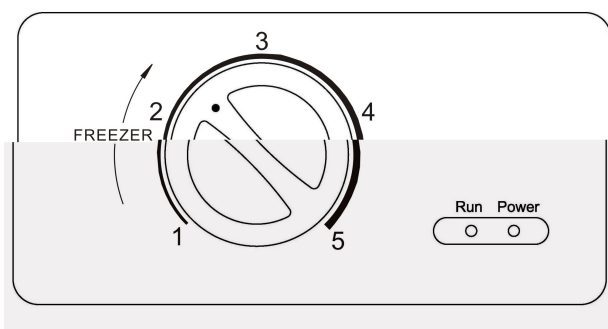

“3” should be appropriate for home or office freezer use.

- **NOTE;**

- If the unit is unplugged, loses power; you must wait 3 to 5 minutes before restarting the unit. If you attempt to restart before this time delay, the freezer will not start.
- Large amounts of food will lower the cooling efficiency of the appliance.
- If you choose to change the thermostat setting, adjust thermostat control by one numerical increment at a time. Allow several hours for temperature to stabilize between adjustments.

Defrosting Your Freezer

- When? For the most efficient operation and minimum energy consumption, defrost the freezer when the frost on the freezer walls is excessive or ¼ to ½ inch thick.
- Choose a time when the stock of frozen food is low.

CAUTION

Do not use boiling water because it may damage the plastic parts. In addition, never use a sharp or metallic instrument to remove frost as it may damage the cooling coils and will void the warranty.

- Remove the frozen food from the freezer and place it in a cooler to protect the food.
- Unplug the freezer. The Power Supply light should be off (green light out).
- During defrosting, the ice melts into the cabinet.
- Remove the drain plug on the inside floor of the freezer by pulling straight out.
- Place a shallow pan outside drain outlet. The defrost water will drain out.
- Check the pan occasionally so the water does not overflow.
- Clean the interior of the freezer.
- Replace the plug on the inside floor.
- Adjust the temperature control knob to “3”.
- Allow the cabinet to cool for one hour.
- Return food to the freezer.

HELPFUL HINT:

Defrosting usually takes a few hours. Leaving the door open will help speed the process. Also, pouring warm water (not boiling) on the ice/frost will help speed melting.

⚡WARNING⚡

Scraping ice from the freezer compartment can damage the unit.

The Freezer Compartment

- This compartment is designed for the long-term storage of frozen food. Storage time period is up to three months.
- The storage life of frozen foods varies and the recommended storage time should not be exceeded. The instructions regarding the care of frozen foods should be followed when defrosting the freezer.
- Pre-packed commercially frozen food should be stored in accordance with the frozen foods manufacturers' instructions for a three star frozen food storage compartment or home freezer.
- Place frozen food into the freezer as quickly as possible after purchase. If there are instructions on the packet, carefully follow these instructions regarding storage times.
- The freezer lid is susceptible to breaking due to excessive ice build up. Be sure to defrost when the ice reaches ¼ to ½ inch thick.
- A storage basket is provided for the organization of odd-shaped items. To reach other packages

in the freezer, just slide the basket to one side, or lift it out. Additional storage baskets can be purchased via our website at www.magicchef-ewave.com.

CARE AND MAINTENANCE

Cleaning Your Freezer

- Upon installation of your new appliance, it is recommended that it be cleaned thoroughly.
- Unplug the freezer, remove the food and storage basket.
- Wash the inside with a damp warm cloth soaked in lukewarm water and baking soda solution. The solution should be about 2 tablespoons of baking soda to a quart of water.
- Wash the storage basket with a mild detergent solution.
- Be sure to keep the door gasket (seal) clean to keep the unit running efficiently.
- The outside of the freezer should be cleaned with mild detergent and warm water.
- Dry the interior and exterior with a soft cloth.
- The condenser coils should be vacuumed when they are dusty or dirty.
- It is recommended that the unit be cleaned each time it is defrosted to help keep the unit odor free and running efficiently.

Vacation Time

- Remove all the food.
- Unplug the freezer.
- Clean the freezer.
- Leave the lid open slightly to avoid possible formation of condensation, mold, or odors.
- Use extreme caution in the case of children. The unit should not be accessible to child's play.
- **Short vacations:** Leave the freezer operating during vacations of less than three weeks.
- **Long vacations:** If the appliance will not be used for several months, remove all food and unplug the power cord. Clean and dry the interior thoroughly. To prevent odor and mold growth, leave the door open slightly: blocking it open if necessary or have the door removed.

Moving Your Freezer

- Unplug the freezer.
- Remove all the food.
- Securely tape down all loose items inside your freezer.
- Remove the rollers to prevent damage.
- Tape the doors shut.
- Be sure the freezer stays in the upright position during transportation.

Energy Saving Tips

- The freezer should be located in the coolest area of the room, away from heat producing appliances or heating ducts, and out of the direct sunlight.
- Let hot foods cool to room temperature before placing in the freezer. Overloading the freezer forces the compressor to run longer. Foods that freeze too slowly may lose quality, or spoil.
- Be sure to wrap foods properly, and wipe containers dry before placing them in the freezer. This cuts down on frost build-up inside the freezer.
- Freezer storage bin should not be lined with aluminum foil, wax paper, or paper toweling. Liners interfere with cold air circulation, making the freezer less efficient.
- Organize and label food to reduce door openings and extended searches. Remove as many items as needed at one time, and close the door as soon as possible.

TROUBLESHOOTING GUIDE

You can solve many common freezer problems easily, saving you the cost of a possible service call. Try the suggestions below to see if you can solve the problem before calling for service.

PROBLEM	POSSIBLE CAUSE
Freezer does not operate.	Not plugged in. The circuit breaker tripped or a blown fuse.
Compressor turns on and off frequently.	The room temperature is hotter than normal. A large amount of food has been added to the freezer. The door is opened too often. The door is not closed completely. The temperature control is not set correctly. The door gasket does not seal properly. The freezer does not have the correct clearances. The freezer has recently been disconnected for a period of time. 4 hours are required for the freezer to cool down completely.
Temperature inside the freezer is too warm.	Temperature control is set too warm. Turn the control to a cooler setting and allow several hours for the temperature to stabilize. Door is kept open too long or is opened too frequently. Warm air enters the freezer every time the door is opened. Open the door less often. The door is not closed completely. The door gasket does not seal properly. A large amount of warm or hot food might have been stored recently. Wait until the freezer has had a chance to reach its selected temperature. The freezer has recently been disconnected for a period of time. 4 hours are required for the freezer to cool down completely.
Temperature inside the freezer is too cold.	Temperature control is set too cold. Turn the control to a warmer setting and allow several hours for the temperature to stabilize.
Temperature of external freezer surface is warm.	The exterior freezer walls can be as much as 30°F warmer than room temperature. This is normal while the compressor works to transfer heat from inside the freezer cabinet. Thd oe-252.121(T)-15.5073(u)1h w

	<p>freezer. The freezer is touching the wall. Re-level the freezer and move it from the wall. See "Installation Instructions".</p>
Moisture forms on inside freezer walls.	<p>Weather is hot and humid, which increases internal rate of frost build-up. This is normal. Door is slightly open. Door is kept open too long, or is opened too frequently. Open the door less often. The door is not sealed properly.</p>
Moisture forms on outside of freezer.	<p>Door is slightly open, causing cold air from inside the freezer to meet warm moist air from outside.</p>
The door will not close properly.	<p>The freezer is not on a level surface. The gasket is dirty. The storage basket is out of position.</p>



Chest Freezer Warranty

MC Appliance Corporation warrants each new Freezer to be free from defects in material and workmanship and agrees to remedy any such defect or to furnish a new part(s) (at the company's option) for any part(s) of the unit that has failed during the warranty period. Parts and labor expenses are covered on this unit for a period of one year after the date of purchase. In addition, **MC Appliance Corporation** warrants the compressor (parts only) to be free from defects in material and workmanship for a period of 5 years. The consumer is responsible for all labor and transportation expenses related to the diagnosis and replacement of the compressor after the initial one-year warranty expires. **A copy of the dated sales receipt / invoice is required to receive warranty service.**

This warranty covers appliances in use within the continental United States, Puerto Rico and Hawaii. The warranty does not cover the following:

- Damages due to shipping damage or improper installation.
- Damages due to misuse or abuse.
- Content losses due to failure of the unit.
- Inside components such as door panels, door shelves, racks, chest freezer lid liners, light bulbs, etc.
- Punctures to the evaporator system due to improper defrosting of the unit.
- Repairs performed by unauthorized service agents.
- Service calls that do not involve defects in material and workmanship such as instruction on proper use of the product, door reversal or improper installation.
- Replacement or resetting of house fuses or circuit breakers.
- Failure of this product if used for other than for its intended purpose.
- Disposal costs for any failed unit not returned to our factory.
- Any delivery costs incurred as the result of a unit that fails to perform as specified.

This warranty is in lieu of all warranties expressed or implied and no representative or person is authorized to assume for us any other liability in connection with the sale of this product. Under no circumstances is the consumer permitted to return this unit to the factory without prior written consent from **MC Appliance Corporation**.

Model	Parts	Labor	Compressor (Part Only)	Type of Service
MCCF5WBX	One-Year	One-Year	Five Years	Carry In
MCCF7WBX	One- Year	One- Year	Five Years	In-Home

For Service or Assistance please call 888 775-0202. Or visit us on the web at www.magicchef-ewave.com to request warranty service.

Magic Chef is a trademark of the Maytag Corporation and is used under license to MC Appliance Corp. All rights reserved.