

# Hotpoint

## FREEZER - MODELS RZA31,RZA33,RZM31,RZM33 INSTRUCTIONS FOR INSTALLATION & USE

**GETTING STARTED:** To ensure that your freezer runs reliably and efficiently follow these steps.

### STEP 1

Choose a location for your freezer, away from any heat sources and allow adequate ventilation - 30mm (1<sup>1</sup>/<sub>4</sub> inch) gap above.



### STEP 2



Move the freezer into position, using the sides of the cabinet. Take care to avoid damaging the refrigerant circuit pipe work on the rear.

### STEP 3

Level the freezer by adjusting the front feet. This will stop rocking or vibration and keep the door aligned.



### STEP 4



Before plugging in and switching on, leave the freezer in its final location for at least 15 minutes to allow it to settle.

### STEP 5

Plug in and switch on. Allow the freezer to cool before placing food inside. The high temperature light will stay on until the freezer has cooled down. All food in the freezer should be covered.



### STEP 6



If you are freezing fresh food, turn on *fast freeze* by pressing the switch 24 hours before placing the food inside. Place the fresh food inside and remember to turn off *fast freeze* after another 24 hours.

### STEP 7

Your freezer is now working. If after 24 hours your freezer is not operating as you want, refer to the TROUBLESHOOTING section.

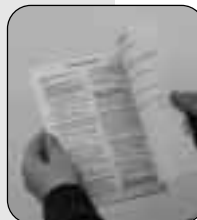

Read the rest of these instructions to get the best from your appliance and remember to fill in your guarantee registration.

Keep this Book in a safe place for quick reference.

SAFETY &  
INSTALLATION

CONTROLS

USEFUL ADVICE

CLEANING &  
MAINTENANCE

TROUBLESHOOTING

SERVICE &  
GUARANTEE

# For Your Safety

## For your safety, read the following advice:

The freezer cooling system contains a small amount of gas which is environmentally friendly but flammable. To avoid any risk :-

- Install the freezer following the installation instructions and ensure that ventilation openings are kept clear of obstruction.
- Take care when installing or moving the freezer to avoid damaging the pipes on the rear.
- If you suspect a leak, do not switch on the freezer, but open the windows and doors to ventilate the room.
- Do not use any electrical devices inside the freezer, for instance for defrosting.
- Do not use any mechanical devices for defrosting other than any which may have been supplied with the freezer as they may cause damage.
- Only use this freezer for storing domestic foodstuffs.

## When installing your freezer :-

- Ensure that the mains cable is not trapped underneath or behind the freezer when you install or move it.
- Do not stack any other appliance on top of this freezer as they may damage the freezer or become unstable.

## When using your freezer :-

- Do not sit or stand on top of your freezer.
- Do not store poisonous, flammable or dangerous substances in your freezer.
- Do not use aerosol sprays for defrosting or cleaning your freezer.

If you sell the freezer, pass on this booklet to the new owner.

# Installation

## Location & Air Circulation

Locate your freezer away from sources of heat e.g. Cookers, Radiators, Direct Sunlight as extreme temperature will affect its performance.

Allow a minimum 30mm (1¼ inch) between the top of the freezer and the underside of the worktop.

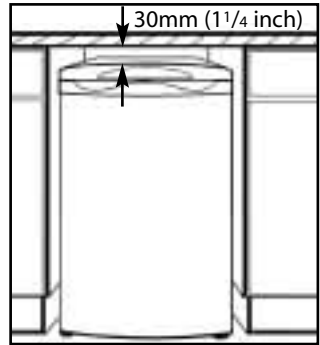

Providing you follow the recommended ventilation requirements you will :-

- Prolong the life of the freezer.
- Minimise the risk of condensation on the outside of the freezer.
- Minimise the running costs.
- Minimise operating sounds caused by vibration.

## Minimum space required to open door

The freezer needs a space of 600mm (24 inches) in front to allow the door to open.

When positioning the freezer next to a unit, a gap of 30mm (1¼ inch) can be left at the hinge side of the door to allow the easy removal of furniture. If preferred the freezer can be positioned so that a gap is not left. This will restrict how far the door can be opened but the furniture can still be removed (see diagram below). The door hinge side can be changed to make it easier to open (see 'Door Reversal' in the CLEANING & MAINTENANCE section).

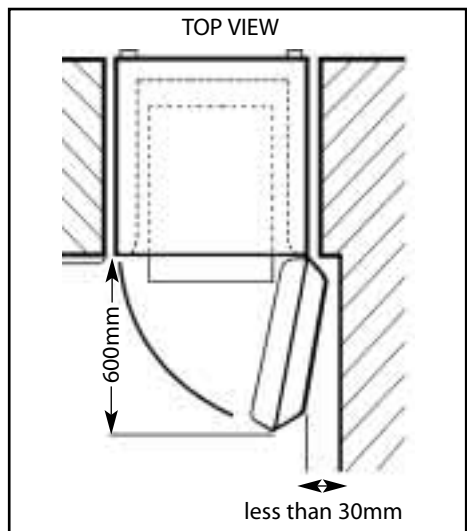
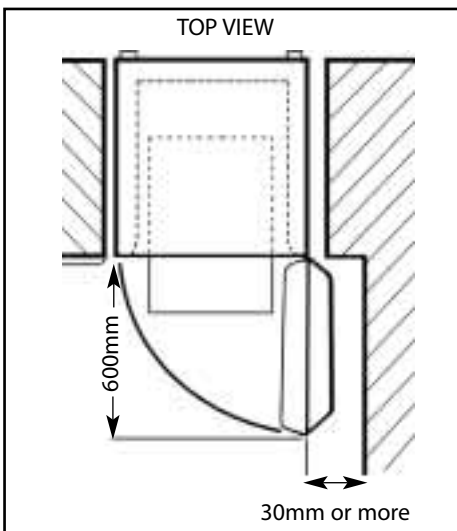

# Installation

## Levelling:

Level the freezer when it is in its final location by adjusting the front feet, until firm contact is made with the floor. This will stop rocking or vibration and keep the door aligned which helps the freezer run reliably and efficiently.

Before plugging in and switching on, leave the freezer standing in its final location for at least 15 minutes to allow it to settle.

## Fitting a Freezer under a Work Top

To minimise running costs Hotpoint recommend fitting a vent to the rear of your worktop, which is available from Hotpoint Genuine Parts & Accessories Mail Order Hotline (see KEY CONTACTS, back page).

**WARNING:** If there is less than 30mm clearance above the freezer, a vent must be fitted to provide adequate ventilation above your freezer.

# Installation

## Electrical Supply

**WARNING:** This appliance must be earthed.

**The freezer must be positioned so that the plug is accessible after installation.**

## Fuses

Your appliance comes fitted with a plug and a 13A fuse. If you need to replace the fuse, only use those rated at 13A and ASTA approved to BS1362.

## Changing the Plug

Cut off and dispose of the supplied plug if it does not fit your socket.

**WARNING:** To avoid a shock hazard do not insert the discarded plug into a socket anywhere else.

IMPORTANT WIRES IN THE MAINS LEAD ARE COLOURED IN ACCORDANCE WITH THE FOLLOWING CODE :

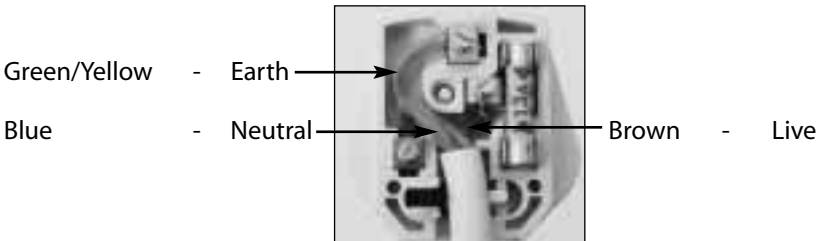

If you change the plug, the colour of wires in the mains lead may not correspond with the colour of the markings identifying terminals in the plug. You should therefore wire it as shown above.

## Changing the Mains Lead

This freezer is fitted with a special mains lead. If you need to replace the mains lead due to damage, one can be bought from Hotpoint Service (see KEY CONTACTS, back page). It is strongly advised that this work is carried out by a qualified electrician.



CE Marking certifies that this appliance conforms to the following EEC directives : Low Voltage Equipment - 72/23/EEC & 93/68 EEC  
Electromagnetic Compatibility 89/336/EEC, 92/31/EEC & 93/68/EEC

# Controls

## Controlling the Temperature of the Freezer Compartment

The control wheel on the front of the worktop adjusts the internal freezer temperature. Your food should be maintained at  $-18^{\circ}\text{C}$  or colder for long term storage.

The setting of the control wheel will depend on the location of the freezer, the room temperature and how often the door is opened. The normal set point (marked by a 3 and N on the dial) is usually suitable. If you need to adjust the temperature turn the control wheel:

Clockwise (higher number) - **Colder**

Anti-clockwise (lower number) - **Warmer**

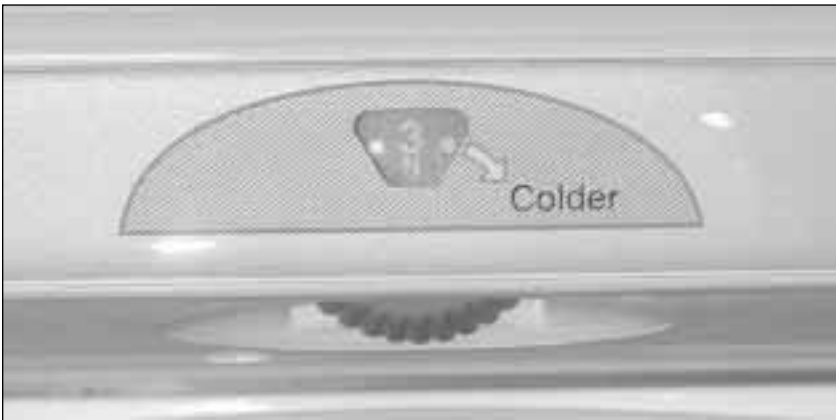

You can check the temperature of the freezer compartment by using a Fridge Freezer Thermometer available from Hotpoint Genuine Parts and Accessories Mail Order Hotline (see KEY CONTACTS back page).

**WARNING:** Do not use a mercury filled thermometer, as breakage would cause a health hazard.

Your freezer must NOT be placed in a room where the temperature goes below  $2^{\circ}\text{C}$  or above  $38^{\circ}\text{C}$  for prolonged periods, as the internal freezer temperature will not be maintained.

# Controls



## Indicator Lights

### Green Mains Light

The green mains light will stay on as long as the electricity supply is not interrupted.

### Amber Fast Freeze Light

The amber light indicates that the fast freeze button has been pressed on. By pressing this button on the freezer motor will run continuously for extra cooling.

### Red High Temperature Warning Light

The red temperature warning light will come on when the freezer is first switched on or when the temperature inside the compartment rises above the correct storage temperature. Check the TROUBLESHOOTING section before calling for advice. The red light may come on for a short period when opening the freezer door to load or unload food, in this case storage times will not be affected.

# Controls

## Fast Freeze Button - Freezing fresh food

The top compartment, with or without the drawer, should be used to freeze fresh food. Transfer already frozen food to one of the lower compartments/drawers.

- Before loading **2kg or more** of fresh food select fast freeze for the required pre-freeze time (see chart below).
- If freezing **up to 2kg** of fresh food just select fast freeze when loading.

Once the fresh food is loaded leave fast freeze on for 24 hours to freeze the food as quickly as possible.

Maximum freezing capacity 15kg in 24 hours

**Note : Don't forget to turn fast freeze off after 24 hours.**

### Pre-Freeze chart when selecting Fast Freeze:

Load for freezing	Pre-freeze time	Load position
10 to 15kg max.	24 hours	Directly on the top compartment grid (remove drawer).
5 to 10kg	12 hours	Directly on the top compartment grid OR in the top drawer.
2 to 5kg	6 hours	Directly on the top compartment grid OR in the top drawer.
up to 2kg	not required	Directly on the top compartment grid OR in the top drawer.



# Useful Advice



**Note:**

**The Rating Plate, which lists the appliance Model Number and Serial Number can be found near the bottom of the left hand internal wall.**

Frozen food storage capacity	33kg
Maximum freezing capacity in 24 hours	15kg
Maximum conservation time from failure	18 hours

## **Making the best use of your Freezer**

**Note : Always use the handle provided to open the freezer door.**

To ensure that your freezer operates as efficiently as possible :

- Follow food packaging “best before/use by” instructions or your suppliers advice on a suitable maximum storage time.
- Keep foods tightly covered to retain moisture and prevent flavour/odour transference. Plastic bags, aluminium foil, plastic stretch wrap and containers with lids are ideal.
- Select chilled and frozen food last when shopping, transport in a ‘cool bag’ and place in freezer as soon as possible after arriving home.
- Avoid opening the door unnecessarily or for longer than needed.
- Allow hot or warm food to cool down in covered containers before placing in freezer, as placing hot food inside reduces efficiency.
- Prepare fresh foods for freezing in small quantities to ensure that the food freezes quickly and so that its quality does not deteriorate.
- Ensure that packets/containers of food are dry before freezing otherwise they may freeze together.

# Useful Advice

## Storing Food in a Freezer

- Freeze and store either fresh food or long term commercially frozen foods.
- Generally speaking long term storage means up to 3 months but this can vary, so always follow your supplier's recommendations otherwise refer to the pictorial guide on the door liner (see below).



- Place frozen food in the freezer compartment as soon as possible after buying it.
- Liquid-filled bottles or sealed fizzy drinks must not be stored in freezer, as they may burst.
- Lollipops and water ices should not be given to children directly from the freezer the low temperature may cause 'freezer burns'.
- Store ice cream towards the top front of the freezer and remove from freezer 15-30 minutes before serving.
- Ensure food is labelled and dated before placing in freezer.
- When freezing fresh food follow the instructions for using fast freeze (see CONTROLS section).
- Do not allow fresh food to come into contact with food already frozen, the frozen food could start to defrost.
- Once thawed, food should be cooked and eaten within 24 hours or cooked and refrozen.
- Fully defrost your freezer when the ice is between 3-5mm thick (1/4 inch) (see CLEANING & MAINTENANCE section).

**Note : A thick layer of ice will increase the running costs of your freezer.**

# Useful Advice

## Advice on Using Freezer Drawers

This freezer can be used with or without the drawers. However, the bottom drawer needs to remain in position at all times (to maintain the correct storage temperature).

It is generally more convenient to use the drawers but if a lot of food is to be stored the drawers can be taken out and food placed directly onto the grids.

Ensure that packets/containers of food are thoroughly dry before placing onto the grids.

The storage drawers can be easily removed. Pull the drawer towards you until it reaches its stop position. Hold securely on both sides, lift the front of the drawer to release and remove.

For cleaning advice see CLEANING & MAINTENANCE section.

When using the frozen food storage drawers, ensure that they are pushed fully back before closing the door.

Food can be separated into different storage drawers for easy identification.

When lifting or removing the large deep drawer it is important to hold the side handles and not the front handle.

**WARNING:** The freezer drawers can become heavy when fully loaded with food. Care must be taken if attempting to lift or carry a full freezer drawer. It is recommended to remove the required food, rather than the whole freezer drawer.

**Note : It is important not to touch or move any of the freezer drawers/parts with wet hands as it may cause freezer burn or discomfort.**

## Ice Tray

When making ice, use the tray provided. Take care not to overfill with water.

Uncovered food should not be placed near the ice tray as it can affect the flavour of the ice.

**Note : Empty, wash and refill the ice tray periodically to ensure freshness.**

# Defrosting

## Defrosting

Regular use of your appliance causes ice to gradually build up on internal surfaces increasing the running costs of your appliance. When the ice is between 3-5mm (1/4 inch) Hotpoint recommend 'fully defrosting your freezer'.

### Fully defrosting your freezer.

**WARNING:** Switch off the electricity supply and pull out the mains plug.

1. Remove frozen food, wrap or cover and store in a cool place.
2. Remove the storage drawers
3. A defrost tube is stored in the floor of the freezer. Insert the tube into the groove situated in the floor at the front of the freezer. Place a container beneath the tube to collect the defrost water.
4. As the frost begins to melt, use the supplied plastic scraper to remove frost. Never use sharp metal tools to remove frost as they may damage your freezer beyond repair.
5. Sponge out excess defrost water which collects at the bottom of the freezer.

**NOTE :** *When defrosting is complete, clean the interior thoroughly, see **CLEANING & MAINTENANCE** section.*

6. Replace storage drawers.
7. Replace mains plug and switch on. Unwrap food and replace.



# Cleaning

## Cleaning

**WARNING:** Switch off electrical supply and pull out mains plug before cleaning.

### Interior

1. Remove food and wrap or cover to keep it frozen.
2. Remove drawers from each compartment and wash in warm water and washing up liquid using a soft cloth, dry thoroughly.

**Note : It is important to ensure that cleaned baskets are thoroughly dried before refitting to the freezer compartment.**

3. Wipe interior and fittings with a clean cloth wrung out in a solution of either one teaspoon of bicarbonate of soda to one pint of water or Milton™ sterilising fluid, diluted according to the manufacturer's instructions.
4. Dry interior thoroughly with a clean cloth before replacing fittings and food.

### Exterior

Use a clean soft cloth wrung out in warm water and washing up liquid to wipe the exterior surface, dry thoroughly.

**WARNING:** Do not use abrasive powder, household cleaner, bleach or wax polish to clean your freezer, they leave a smell in the freezer and can damage the exterior.

Use a soft brush or vacuum cleaner to remove dust from underneath the freezer and from the compressor and condenser situated at the back of the freezer.

**WARNING:** Do not damage the pipework.

### Door Seal

Use warm water and a clean soft cloth to wipe along and in between the creases of the door seal, dry thoroughly. Take care not to damage the seal and avoid using sharp objects.

**WARNING:** Do not use detergent, it will damage the seal.

### Going Away

If you are going away and don't want to use your freezer, switch off electricity supply and pull out the mains plug. Remove food and follow the defrosting and cleaning instructions above.

**Note : Leave the door ajar to prevent an accumulation of odours.**

# Maintenance

You will need a selection of small hand tools, screwdrivers, spanners etc. to carry out this procedure.

Our Service Department can arrange for an Engineer to do the conversion for you but a charge will be made.

## Door Reversal

**WARNING:** Switch off electrical supply and pull out the mains plug.

Remove loose items/fittings from inside the fridge and place food into insulated containers whilst carrying out this operation.

1. Open the door as wide as possible.

**Note : You may require assistance to do this:**

2. Support the door and using a screwdriver, remove the screw securing the top hinge.

3. Carefully tilt the door to remove the hinge from the cabinet and lift the door off the bottom hinge.

4. Remove the spacing washers from the bottom hinge.

**Note : You may require assistance to do this:**

5. Using the packaging from the appliance or a suitable substitute to support the back of the appliance. Lay the appliance on it's back ensuring the pipework at the back is not damaged or bent. **Be careful that the appliance does not run away from you when the wheels touch the floor.**

6. Unscrew the foot plate and hinge bracket fitted to the bottom right hand side of the appliance. Unscrew the foot and footplate fitted to the bottom left hand side of the appliance.

7. Refit the hinge bracket and the footplate to the opposite sides of the appliance. Screw in the feet until there is approximately 35mm projecting from the bottom front edge of the appliance.

8. **Lift the appliance onto it's feet. You may require assistance to do this:**

Lift the appliance from the rear of the tabletop and stand it on it's feet and wheels. **Be careful that the appliance does not run away from you when the wheels touch the floor.**

9. Using a thin blunt instrument, remove the hinge bush cap from the top left of the door and refit on the top right.

10. If applicable - using a screwdriver, remove the door stop from the bottom right of the door and refit on the bottom left.

**Note : You may require assistance to do this:**

11. Replace the top hinge onto the door, slide the door onto the bottom hinge pin and support the door whilst screwing the top hinge into position. Ensure that the top hinge bracket is positioned correctly.

12. Adjust the front feet (see 'Levelling' SAFETY & INSTALLATION section).

**Note : Let the appliance stand upright in it's final location for at least 15 minutes before plugging in and switching on the electricity supply.**

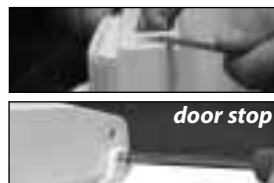

# Troubleshooting

## IS THE FREEZER WORKING AS YOU WANT?

Have you read through the instruction book ?

If you still have a problem, before calling our service organisation see if any of the tips below help.

### The appliance will not work

1. Check plug is firmly positioned in the socket outlet and the power supply is switched on.
2. Check power supply with another appliance.
3. Check fuse/circuit breaker.
4. Check the door is closed properly.

### The appliance is making a lot of noise

1. Check that the rear pipe work is clear of the wall, skirting board and other obstacles.
2. Check that all four feet/wheels are firmly in contact with the floor and level.
3. See 'Operating Sounds' overleaf.

### The freezer is too warm

1. Turn the control wheel to a higher number. See CONTROLS section.
2. If the appliance is close to a heat source, move it to another location.
3. Check that there is enough ventilation around the appliance.
4. Check door has been closed properly.

### The freezer is too cold

1. Turn the control wheel to a lower number. See CONTROLS section.

### The red warning light will not go out

1. Has the appliance just been installed? (This is normal and the light will go out when the correct temperature has been reached).
2. Has the appliance just been loaded with a large quantity of food. (The light will go out once all the food has

reached the correct temperature).

3. Check door has been closed properly.

### The Amber light is on

1. The fast freeze button has been left "on".

### There has been a power failure

**WARNING:** Do not open the freezer compartment door.

If power failure lasts longer than the maximum conservation time (18 hrs), food should either be cooked and eaten with 24 hours or cooked and refrozen.

### The freezer door is difficult to open

A well sealed freezer door can be difficult to open. This is partly due to the difference in temperature between the room and internal freezer compartment. If you have just closed the freezer door, it maybe particularly difficult to open again immediately. Wait 5 minutes for the internal and external pressure to equalise and try again.

### Ice builds up rapidly inside the freezer

1. Check that nothing is stopping the door from closing properly.
2. Check that foods and liquids are covered to avoid the build up of moisture inside.
3. See 'Defrosting' in the CLEANING & MAINTENANCE section for advice.

### The door will not close

1. Check to see if the appliance has a build up of ice which is stopping the door closing. If this is the case refer to 'Defrosting' in the CLEANING & MAINTENANCE section and defrost the appliance.

If there is still a problem contact Hotpoint Service (see KEY CONTACTS back cover).

# Troubleshooting

## OPERATING SOUNDS OF A FRIDGE FREEZER

These are the normal types of sound that your freezer will make.

- The motor (compressor) makes a buzzing or humming sound when it is running. This can be louder when it first switches on. This sound will reduce over the first few months.
- Gases flowing through the pipes can produce gurgling, bubbling, roaring or humming noises.
- The temperature control can make a clicking noise when it turns the motor on and off.
- Expansion and contraction of parts inside the freezer can produce a cracking noise as they rapidly change temperature.



## Hotpoint guarantee

### “Satisfaction guaranteed or your money back”

We give you a unique ‘satisfaction guaranteed’ promise - **valid for 90 days** - after you have purchased your Hotpoint appliance. If there is a technical problem simply call Hotpoint Repair service or visit our web-site at [www.hotpointservice.co.uk](http://www.hotpointservice.co.uk) and where necessary, we will arrange for an engineer to call. If the technical problem is not resolved under this guarantee, **we will replace your appliance or, if you prefer, give you your money back.**

All Hotpoint appliances carry a fully inclusive 12 month parts and labour guarantee as well as free replacement parts for the first 5 years (except microwaves, selected integrated appliances and cooker hoods, which have a one year guarantee) provided that they are fitted by a Hotpoint engineer.

### Guarantee terms and conditions

Your guarantee is only applicable in the United Kingdom or Republic of Ireland and is subject to the following provisions that your appliance:

- Has been installed and used correctly in accordance with this instruction booklet.
- Has been used solely for domestic purposes and is located on domestic premises (ie. not for commercial or trade use).
- Has been properly connected to a suitable electrical supply voltage as stated on the appliance rating plate.
- Has not been subject to misuse, accident, modified or repaired by anyone other than a Hotpoint service engineers.



For pre purchase information on any other Hotpoint product call: 08701 50 60 70  
or visit: [www.hotpoint.co.uk](http://www.hotpoint.co.uk)



## Recycling & Disposal Information

As part of Hotpoint’s continued commitment to helping the environment, Hotpoint reserves the right to use quality recycled components to keep down customer costs and minimise material wastage.

Please dispose of packaging and old appliances carefully. Old refrigerant and oil must be disposed of in a safe and environmentally friendly manner, using suitably qualified personnel.

To minimise risk of injury to children, remove the door, plug and cut mains cable off flush with the appliance. Dispose of these parts separately to ensure that the appliance can no longer be plugged into a mains socket, and the door cannot be locked shut.

## After Sales Service

**“No company is better positioned to offer an after sales service on a Hotpoint appliance than us - the manufacturer”**

As part of our commitment to you, all Hotpoint appliances have the added benefit of a fully inclusive parts and labour guarantee for the first 12 months. In addition to this you also have the advantage of **free replacement parts for the first 5 years** when fitted by a Hotpoint engineer. When the 12 months parts and labour guarantee expires we offer the following after sales service options:

### ***Repair Service and Information Help Desk***

UK: 08709 066 066

[www.hotpointservice.co.uk](http://www.hotpointservice.co.uk)

Republic of Ireland: 1850 302 200

Note: Our operators will require the Model number and the Serial number of your appliance (see USEFUL ADVICE SECTION for rating plate position).

Available 364 days a year with a fast, effective and value for money service. We have the largest white goods repair service in the UK with over 1100 of our own fully trained engineers. All repairs include a parts and labour guarantee for 12 months from the date of the repair. If you require any information or have any questions about your appliance, our operators are on hand with help and advice.

All this ensures that you will receive the best available after sales service possible.

### ***Extended Warranties***

UK: 08709 088 088

[www.hotpointservice.co.uk](http://www.hotpointservice.co.uk)

Republic of Ireland: 1850 502 200

Whether you have just one or a number of Hotpoint appliances in your kitchen, we offer two service cover plans to give you total peace of mind.

- Repair Protection Plan - FREE service repairs for a single Hotpoint appliance during the period of cover.
- Kitchen Cover - FREE service repairs for all your Hotpoint appliances less than 8 years old.

### ***Genuine Parts and Accessories***

UK: 08709 077 077

[www.hotpointservice.co.uk](http://www.hotpointservice.co.uk)

Republic of Ireland: (01) 842 6836

A wide range of genuine parts and accessories are available from our hotline or through our web site.

**Genuine parts and accessories, extended warranties and service repairs are all available on our web-site at:**

[www.hotpointservice.co.uk](http://www.hotpointservice.co.uk)

# Notes



## Key Contacts

### After Sales Service

Over 1100 trained specialists, directly employed by us, ensure that you can have complete confidence in both the appliances and services we offer.

### Repair Service and Information Help Desk

UK: 08709 066 066

Monday to Friday, 8am to 7.30pm

Saturday, 8.30am to 5.30pm

Sunday, 9.30am to 3.30pm

[www.hotpointservice.co.uk](http://www.hotpointservice.co.uk)

Republic of Ireland: 1850 302 200

Note: Our operators will require the following information:

Model number

Serial number

See **USEFUL ADVICE SECTION** for rating plate position

### Extended Warranties

UK: 08709 088 088

Monday to Sunday, 8am to 8pm

[www.hotpointservice.co.uk](http://www.hotpointservice.co.uk)

Republic of Ireland: 1850 502 200

### Genuine Parts and Accessories

UK: 08709 077 077

Monday to Friday, 8.30am to 5pm

Saturday, 8.30am to 12noon

[www.hotpointservice.co.uk](http://www.hotpointservice.co.uk)

Republic of Ireland: (01) 842 6836

[www.hotpoint.co.uk](http://www.hotpoint.co.uk)

**Indesit** Company UK Limited, Morley Way, Peterborough, PE2 9JB