

Haier THERMOCOOL

BD-66A

CHEST FREEZER

USER MANUAL



BD-66A

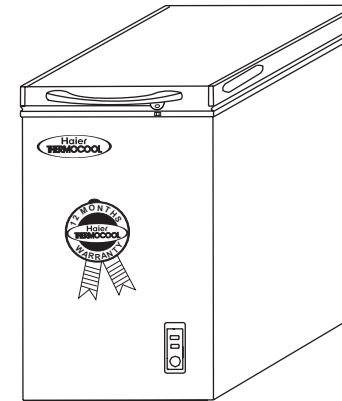

IMPORTANT

Please read this Owner's Manual carefully before using your freezer. Keep in a safe place for future reference.

Thank you for choosing 

Table of Contents

Outline Drawing	Page 1
Important Safeguards	Page 2-3
Electric Control panel	Page 4
Freezer Installation	Page 5
Energy Saving Tips	Page 6
Operating the Freezer	Page 6-7
Care and Cleaning	Page 8
Defrosting	Page 9
Useful Hints	Page 10
Troubleshooting	Page 10-11
Guide to Home Freezing	Page 12
Accessories List	Page 13
Technical Data and Wiring Diagram	Page 14
Warranty	Page 15
ATTACHMENT	page 16

ATTACHMENT

Step of handle installation:

1 Firstly, fix the handle on the right position marked on the foamed lid in advance with four screws, then fasten the four screws.

2 Secondly, insert the narrow plastic sheet in the handle's recess, and make sure that both the ends of the plastic sheet are stably fixed in the recess, then press the sheet gently until the gap between the edges of the sheet and recess is not visible.



- (1) Hinge
- (2) Sealing gasket
- (3) Light
- (4) Food Basket
- (5) Drain Plug
- (6) Control Panel
- (7) Ventilation grill for compressor
- (8) Lock
- (9) Handle

Included in the
Following Models
BD-66A

- Yes
- Yes
- No
- Yes
- Yes
- Yes
- Yes
- Yes
- Yes

DANGER

AVOID THE RISK OF CHILD ENTRAPMENT.
BEFORE THROWING AWAY AN OLD REFRIGERATOR OR FREEZER, TAKE
OFF THE DOORS/LIDS AND REMOVE THE SHELVES SO THAT CHILDREN
CANNOT GET TRAPPED INSIDE.

Important Safeguards

Read all instructions before using this appliance.

When using this appliance, always exercise basic safety precautions, including the following:

- 1) Use this appliance only for its intended purpose as described in this guide.
- 2) Remove all packaging before commencing freezer operation.
- 3) This freezer must be installed properly in accordance with the installation instructions before it is plugged in and used. See grounding instructions in the installation section.
- 4) This freezer is designed for freestanding installation only and it should not be recessed or built in.
- 5) At least 7.5cm air space on top, sides and back of the freezer should be given. This allows air to circulate freely and helps to prevent condensation on the cabinet.
- 6) It is recommended that the freezer is cleaned before use as per the 'Care and Cleaning Instructions' in this manual.
- 7) Never unplug your freezer by pulling on the power cord. Always grip the plug firmly and pull it straight from the outlet.
- 8) Replace or repair immediately all electric service cords which may have become frayed or otherwise damaged. Do not use cord that shows cracks or abrasion damage along its length or at either the plug or connector end.
- 9) If your old freezer is still around the house but not in use, be sure to remove the doors to reduce the possibility of danger to children.
- 10) Unplug your freezer before cleaning or before making any repairs. **NOTE:** We strongly recommend that any servicing or repairs be undertaken by a suitably qualified technician.
- 11) Do not refreeze any foods which have been thawed.

Warranty Information

Haier THERMOCOOL

The **Haier THERMOCOOL** 12-MONTH WARRANTY gives you piece of mind and assured satisfaction from the moment of purchase. Under normal use, the 12-MONTH WARRANTY covers free parts replacement under warranty and free repairs under warranty. Damage caused by misuse is not covered by the warranty.

Extensive **Haier THERMOCOOL** NATIONWIDE SALES AND SERVICE NETWORK offers you fast and reliable service and replacement parts which will normally be available for many years.

HPZ Sales and Service Depots are available in:

Lagos (Isolo Sales Depot,) Ibadan, Akure, Oshogbo, Ilorin, Benin, Warri, Port Harcourt, Aba, Onitsha, Enugu, Abuja, Minna, Kaduna, Jos, Zaria, Kano, Maiduguri, Gombe, Yola and Sokoto.

Contact **HPZ** Ltd or your local **Haier THERMOCOOL** distributor for information.



...part of your life

Haier THERMOCOOL reserves the right to amend specifications without notice as part of a continuous improvement programme. “” is a registered trademark.

 **Limited**

45/47, Town Planning Way, Ilupeju Industrial Estate,
P.M.B 21132, Ikeja, Lagos, Nigeria.

Tel: 01-4973474, 01-5554768, 01-5553288-90,

Fax: 01-5553289, 01-4962076,

E-mail: sales@hpz.com.ng

WWW.htcool.com



Technical Data and Wiring

Main Technical Data – HFC Variant

Model	Volume (L)	Power (V/Hz)	Power Watts	Climate Classification	Freezing Capability (kg/24h)	Power Consumption (Kw h/24h)	Thickness of Wall (MM)	Net Weight (kg)	Size (mm)	Star rating
BD-66A	66	220/50	110	T	6	0.65	65	30	455x650x875	****

Features and Specifications

Haier THERMOCOOL produce high quality appliances which are strong, reliable, elegantly styled, yet practical and long lasting for the most demanding climates and conditions in the tropics.

Haier THERMOCOOL appliances are built with high efficiency, rigid cyclopentane insulation in doors/lids and cabinets. Lid gasket seals are specified for maximum insulation and energy efficiency.

Wiring Diagram

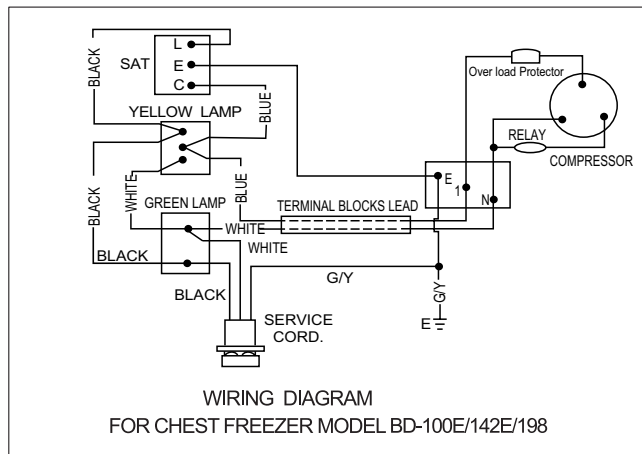

- 12) Do not use any electrical devices or sharp instruments to defrost the freezer.
- 13) Food should only be placed inside the freezer 8 hours after the freezer has been turned on to avoid wasting power and over working the compressor.
- 14) Ensure that hot food is allowed to cool completely before freezing.
- 15) Do not overfill the freezer. Where possible, large blocks of meat should be cut and wrapped in smaller pieces. Space should be left between packages of food to enable air to circulate at all times.
- 16) Never place combustible, explosive or volatile liquid, gas or other materials in the freezer.
- 17) Do not install the freezer in the same vicinity of any combustible, explosive or volatile liquids/gases.
- 18) Do not leave beverages such as beer, soft drinks or other liquids packaged in glass containers in the freezer. Such liquids will expand upon freezing and can cause the glass to break.
- 19) Do not put water directly in to the tank of the freezer.

Electric Control Panel

The main functions of the electric control panel are:

- 1) The control panel is numbered 1,2,3,4,5,6,7. This refers to the temperature on the inside of the freezer. The temperature is lowered by turning the dial in clockwise direction.
 - Refrigerate: When dial is near the "1" position, the interior average temperature of freezer is approximately $10^{\circ}\text{C} \sim -2^{\circ}\text{C}$.
 - Freeze: When dial is near the "2-7" position, the interior average temperature of freezer is approximately $-2^{\circ}\text{C} \sim -26^{\circ}\text{C}$.

When you change the dial from refrigerate function to freeze function, the food in the freezer should be taken out to avoid freeze.
- 2) The green lamp is used to indicate that the appliance is connected to a power supply and is 'on'. The green lamp will be illuminated when the freezer is connected to an appropriate power supply.
- 3) The yellow lamp will be illuminated when the 'Super Freeze' switch is in 'on'. The compressor continues cooling until the 'Super freeze' is turned to 'OFF' again.
- 4) All control equipment is installed on the control panel situated on the exterior of the freezer.

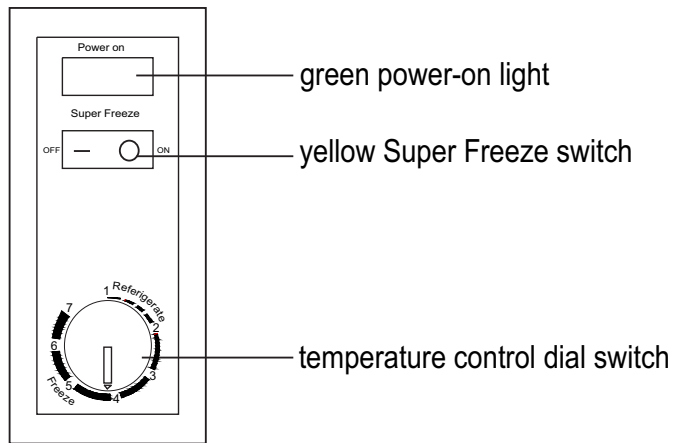

Accessories List

<u>Description</u>	<u>Quantity</u>
	BD-66A
Food Basket	1
Plastic Frost Scraper	1
User Manual	1
Keys	2

Guide to Home Freezing

Recommended maximum duration of storage for various foods. For best results it is recommended that Freezer Bags are used for storing foods.

Meat and Poultry

Meat can be frozen in various ways. Do not Freeze Large packets or pieces, as this will ruin meat quality.

Beef	raw, joint	6-8 months
Beef	roasted	10-12 months
Beef Steak	raw, joint, steak	10-12 months
Beef Fillet	raw, joint, steak	6 months
Lamb	raw	6-12 months
Chicken	raw, cleaned	6 months
Pork	cutlets raw	3 months
Veal	cutlets raw	10-12 months
Venison	cutlets raw	12 months

Fruits and berries

Orange	Squeezed	12 months
Grapefruit	Squeezed	12 months
Apricot	Washed, sliced	12 months
Grape	Bunch	12 months
Apple	peeled, pips out	12 months
	cut in half, diced	12 months
Rhubarb		12 months
Plum	stone removed and cut into halves	12 months

Fish and Seafood

Fish can be frozen in various ways

Trout	raw, cleaned	
	Whole or fillet	4-6 months
	Smoked	1 month
Lobster & Prawns	boiled	3 months
	raw, cleaned	
	Whole or fillet	3 months
	Smoked	3 months
Cod	raw, cleaned	
	Whole or fillet	8-12 months
Barracuda, Mackerel & other fish	raw, cleaned	3 months
	Smoked	1 month

Vegetables, Mushrooms and Spices

Most vegetables can be frozen

Aubergine		12 months
Cauliflower		10-12mths
Broccoli		10-12mths
Beans		12 months
Dill		10-12mths
Kale		12 months
Corn cob		12 months
Peppers		12 months
Horseradish		12 months
Parsley		12 months
Beetroot		12 months
Celery		12 months
Spinach		12 months
Peas		10-12mths
Mushroom		10-12mths

Ready Prepared Food

It is both practical and economical to freeze Remember that the duration of storage depends on the fat Contained in the food

Bouillon		6 months
Fish, boiled		10-12 months
dish or soup	4-5 months	
Vegetable dish		3-6 months
Hamburger		3-6 months
Stew		6 months
Pizza		3-4 months

Bread and Pastry

Bread can be frozen both whole and sliced. Remember that the duration of storage depends on Fish the fat contained in the bread and pastry.

Rye bread		6 months
Wheat bread		3-6 months
Pastry		3 months
Biscuits		3 months

Food which should not be frozen

Avocado	Marmalade
Egg	Tomatoes
Lettuce	Banana
Mango	Papaya
Omelette	

Freezer Installation

- 1) The freezer is designed for free-standing installation only.
- 2) The freezer should not be recessed or built in.
- 3) Install the freezer on a base strong enough to support it when fully loaded. Ensure the freezer is on a stable surface to minimise noise and vibration.
- 4) Install the handle: you can find the handle in the foodbasket, and loosen the screws of the door, install the handle on the door, then tighten the screws, in the end, clock the handle lid in the handle.
- 5) When moving the freezer, never tilt at an angle more than 45° as this could damage the compressor and freezer system. If the freezer is tilted over 45°, or has been stored on its side, allow the freezer to stand upright for at least 24 hours prior to plugging it back in. This will allow the refrigerant to settle.
- 6) Install the freezer in a well-ventilated area away from any heat source or direct sunlight. Air must be allowed to circulate freely around the freezer. Allow at least 3 inches (7.5cm) of clearance space for the top, back and sides.
- 7) Install the freezer in a dry place to prevent rust from forming on the compartment body and to avoid the risk of damaging the electric insulation.

Electrical Connection and Precautions

- 1) IMPORTANT – For personal safety, this appliance must be properly earthed.
- 2) The voltage range for this appliance is 187v – 242v. In the event that your regional power supplier cannot meet this requirement, please use a safe and reliable automatic voltage regulator with a minimum output of 500W to avoid damaging the compressor.
- 3) A 13 Amp, 3 pin plug and 5 Amp fuse only must be used for this freezer to avoid serious damage. The plug should always be wired in accordance with the following codes:

Green and Yellow	EARTH (E)
Blue or Black	Neutral (N)
Brown or Red	LIVE (L)

It is safest to consult a qualified electrician at all times

- 4) In the event of an electrical short circuit, grounding reduces the risk of electric shock by providing an escape wire for the electrical current. This appliance is

fitted with a cord having a grounding wire with a grounding plug. This plug must be plugged in to an outlet that has been properly installed and grounded.

- 5) Consult a qualified electrician or service centre if the grounding instructions are not completely understood, or if any doubt exists as to whether the appliance is properly grounded.

Energy Saving Tips

- Do not place your freezer next to a heating vent, cooker, in direct sunlight or in the vicinity of any other heat-producing source.
- Keep the door closed as much as possible, especially in hot and humid weather
- Defrost the freezer every few months or when the frost becomes 6mm (1/4") thick or more.
- Cover foods securely to reduce moisture build up inside the freezer.

Operating Your Freezer

Voltage Supply

To start your freezer it must be connected to a 220-240 volt, 50Hz A.C. power supply. Failure to do so may invalidate the guarantee.

Once the freezer is properly plugged in, the green Power light will illuminate, indicating that the freezer is in operation.

Temperature/Cold Control

The temperature control dial has settings from '1' to '7' , where '1' is the warmest and '7' is the coldest temperature setting. Turn the control knob to higher numbers for colder temperatures.

During extremely hot weather and frequent lid openings, it is advisable to select a higher setting to ensure that food remains frozen.

Initially, set the temperature control knob to the "4" setting by turning the knob in a clockwise direction. After 30 minutes, you should notice an obvious decrease in the interior temperature of the freezer.

Let the freezer to run for a further 12 hours before placing your food inside, allowing some space between items to allow air to circulate properly. After using the freezer for 24 hours, adjust the temperature control to the setting that is best suited to your need.

3) There is condensation on the surface . THIS IS ESPECIALLY COMMON IN CLIMATES WITH HIGH HUMIDITY AND IS NOT A DEFECT. CLEAN THE CONDENSATION WITH A DRY CLOTH.

Troubles/Problems	Reasons	Solutions
Green indicating lights is off	Power is off. The plug is not inserted. The fuse is blown/burnt. The indicating lamp is out of use Circuit breaker tripped Cable is damaged.	Check your main circuit. Insert plug and switch on socket. Change the fuse (5 amp) Change the indicating lamp bulb. Reset breaker. Call electrician to repair.
The temperature is not low enough, or red light is on	Temperature setting is not low Enough. The freezer is in direct sunlight or close to a heat source. Too much food has been stored at one time The door is being opened too often	Turn dial to higher number setting. Change freezer location. Place food in the freezer in Batches and use fast/quick freeze feature. Keep door closed for longer.
Too much noise/vibration.	The floor is not level	Change the position of the freezer until the noise level is reduced
The compressor works continuously.	The thermostate setting is too low. The quick freezing switch is on and the yellow lamp is lit.	Turn the dial to increase the temperature. Turn the quick freeze switch to its normal (off) position when the fast/quick freeze period has finished.
Strong odours in the freezer	Splilt food. Food no wrapped correctly. Interior requires cleaning. No baking soda in place.	Reamove spoiled food form freezer and any other food it has been in contact with. Ensure food with strong odour is tightly covered (freezer bags are best). Clean per 'Care and Cleaning' instruction. Place an open box of baking soda inside the freezer. Reaplace every 3 months.

IF PROBLEMS PERSIST, CONTACT AN APPROVED HAIER-THERMOCOOL SERVICE TECHNICIAN . ALWAYS USE A CERTIFIED TECHNICIAN/ELECTRICIAN.

Useful Hints

- If your freezer is to be out of service for any length of time, ensure that the interior is carefully cleaned and dried as per the 'Care and Cleaning' instructions given in the manual. Leave the lid open and disconnect the plug from the power supply.
- Hot Foods should be allowed to cool before being placed inside the freezer.
- Don't try to freeze too much fresh produce at any one time.
- Carry out regular cleaning of the exterior as per the 'Care and Cleaning' instructions given in the manual. This is important if the freezer is subjected to high humidity and heavy condensation.
- Bulb replacement – Always turn off the power supply and remove the plug before removing the light cover.

Safety Notes

- When disposing of an old freezer, ALWAYS remove the lid as a safeguard against small children getting trapped inside.
- DO NOT store flammable or explosive substances in the freezer cabinet.
- DO NOT store any fizzy drinks in the freezer.
- DO NOT store any liquids contained in glass in the freezer.

Troubleshooting

The table below provides some guidance to solving any apparent minor operating problems that might occur occasionally.

It is important to recognize that the following three situations are a part of the normal operation and use of the freezer:

- 1) There is a sound of liquid flowing in the system when the freezer is switched on. THIS IS NORMAL AND IS THE SOUND OF THE REFRIGERANT FLOWING THROUGH THE SYSTEM.
- 2) The exterior of the freezer is warm and the compressor is extremely hot and burns on touching. THIS IS NORMAL.

Power Cut

If you unplug your freezer or experience an electrical outage, ideally wait five minutes before plugging the appliance back in.

Fast/Quick Freeze Switch

Your freezer is equipped with a Fast/Quick Freeze switch (amber) for quicker freezing of fresh food.

It is recommended that the Fast/Quick Freeze switch be switched on 12 hours in advance, before loading the freezer with a lot of fresh food, and left on for 24 hours after loading. When all freezing is complete, switch off the Fast/Quick Freeze switch.

Food Basket

The freezer is equipped with a removable food basket for storing items at a higher level. Where food is dripping, place it into a tray before you start freezing, to prevent contaminating other food already in the freezer.

Lamp Control Switch

The tilt switch controlling the lamp is inside the lid. It controls the lamp automatically when opening or closing the lid.

Lock and Key

Those freezers which have a lid lock, allow you to secure the freezer contents from theft or to simply keep children out of the freezer.

To lock the lid, close the lid securely, insert the key into the lock and turn clockwise until the lid is latched and locked.

To unlock, turn the key in the opposite direction and remove key.

Care and Cleaning

IMPORTANT
Before Cleaning always switch the freezer off and remove the plug from the power supply.

Part	How to Clean
Exterior	<ul style="list-style-type: none"> Wash using warm water and a mild detergent e.g. soap or dishwashing liquid. Rinse thoroughly, wipe clean and dry. DO NOT USE HARSH CLEANERS OR ABRASIVES. Waxing is recommended if humidity is high to prolong the life of your freezer. Use a good quality car wax or appliance wax. DO NOT USE WAX ON PLASTIC PARTS. DO NOT USE BLEACH OR PETROL BASED PRODUCTS TO CLEAN YOUR FREEZER. DO NOT PLACE HOT OR HEAVY OBJECTS ON THE SURFACE OF THE FREEZER TO AVOID DAMAGING THE SURFACE OR DEFORMING THE GASKET.
Interior (some model have this part)	<ul style="list-style-type: none"> Wash with a warm water solution containing either a mild detergent or baking soda (2 tablespoons/30g baking soda to 1 litre warm water). Wipe clean and dry. If fridge and freezer are left empty and disconnected from mains for more than a few days then help prevent odours by leaving an open box of baking soda in the freezer, changing it every 3 months. DO NOT WASH ANY PLASTIC PARTS FROM THE FREEZER IN A DISHWASHER.
Lid Liner / Gasket / Food Basket	<ul style="list-style-type: none"> Wash using only warm water and a mild detergent. Rinse and dry. Liquids such as oil and juice stick easily to the gasket – to clean, wipe with lukewarm water to extend the life of the plastic.

Defrosting

If the frost on the freezer walls reaches a thickness of 6mm or greater, the freezer requires defrosting. It should not be necessary to defrost the freezer more than once every few months and the defrosting process is best carried out when the stock of food is at a low level.

Defrosting

Before defrosting, turn the thermostat to the lowest temperature setting and turn on the Fast/Quick freeze for about four hours. This will enable you to remove any remaining food from the freezer at its lowest temperature. Food removed from the freezer should then be wrapped in several layers of newspaper and placed in a cold refrigerator. Remember that any rise in temperature will shorten the life of the frozen food considerably. **Thawed food should not be re-frozen.**

Once all food has been removed from the freezer, disconnect the power by removing the plug from the power source/socket.

To help remove the frost, use the plastic defrosting scraper provided. DO NOT USE SHARP OR METALLIC INSTRUMENTS TO REMOVE THE ICE. Defrosting usually takes a few hours. To defrost faster, keep the door open and place a bowl of warm water inside the freezer.

Draining the Freezer

Open the inner plug in the bottom of the freezer compartment. Place a tray or other water receptacle beneath the outer drain dial/plug (front lower left of the freezer).

Pull the drain dial out and rotate it until the triangle points downwards. When done, return the triangle to the up position, push the dial back in, and replace the plug inside the freezer compartment. Open the inner plug in the bottom of the freezer compartment. Place a tray or other water receptacle beneath the outer drain dial/plug (front lower left of the freezer).

Cleaning and Temperature Setting

Wipe the interior of the freezer and drain hole with a cloth or clean as described in the 'Care and Cleaning' section of this manual. Reinsert drain plug and plug the power cord back into the power source/socket.

Turn the temperature control to the desired setting. You may wish to use the Fast/Quick Freeze feature for a few hours and then adjust the temperature control to the desired setting.