



FX921V DFI
FX1000V DFI



4-Stroke Air-Cooled V-Twin Gasoline Engine
Service Manual

Quick Reference Guide

General Information	1
Periodic Maintenance	2
Fuel System (DFI)	3
Cooling System	4
Engine Top End	5
Lubrication System	6
Camshaft/Crankshaft	7
Starter System	8
Electrical System	9
Troubleshooting	10

This quick reference guide will assist you in locating a desired topic or procedure.

- Bend the pages back to match the black tab of the desired chapter number with the black tab on the edge at each table of contents page.
- Refer to the sectional table of contents for the exact pages to locate the specific topic required.



FX921V DFI
FX1000V DFI

4-Stroke Air-Cooled V-Twin Gasoline Engine

Service Manual

All rights reserved. No parts of this publication may be reproduced, stored in a retrieval system, or transmitted in any form or by any means, electronic mechanical photocopying, recording or otherwise, without the prior written permission of Quality Assurance Division/Consumer Products & Machinery Company/Kawasaki Heavy Industries, Ltd., Japan.

No liability can be accepted for any inaccuracies or omissions in this publication, although every possible care has been taken to make it as complete and accurate as possible.

The right is reserved to make changes at any time without prior notice and without incurring an obligation to make such changes to products manufactured previously.

All information contained in this publication is based on the latest product information available at the time of publication. Illustrations and photographs in this publication are intended for reference use only and may not depict actual model component parts.

LIST OF ABBREVIATIONS

A	ampere(s)	lb	pound(s)
ABDC	after bottom dead center	m	meter(s)
AC	alternating current	min	minute(s)
ATDC	after top dead center	N	newton(s)
BBDC	before bottom dead center	Pa	pascal(s)
BDC	bottom dead center	PS	horsepower
BTDC	before top dead center	psi	pound(s) per square inch
°C	degree(s) Celsius	r	revolution
DC	direct current	rpm	revolution(s) per minute
F	farad(s)	TDC	top dead center
°F	degree(s) Fahrenheit	TIR	total indicator reading
ft	foot, feet	V	volt(s)
g	gram(s)	W	watt(s)
h	hour(s)	Ω	ohm(s)
L	liter(s)		

EMISSION CONTROL INFORMATION

To protect the environment in which we all live, Kawasaki has incorporated crankcase emission (1) and exhaust emission (2) control systems (EM) in compliance with applicable regulations of the United States Environmental Protection Agency and California Air Resources Board.

1. **Crankcase Emission Control System**

A sealed-type crankcase emission control system is used to eliminate blow-by gases. The blow-by gases are led to the breather chamber through the crankcase. Then, it is led to the air cleaner.

Oil is separated from the gases while passing through the inside of the breather chamber from the crankcase, and then returned back to the bottom of crankcase.

2. **Exhaust Emission Control System**

The exhaust emission control system applied to this engine consists of a carburetor and an ignition system having optimum ignition timing characteristics.

The carburetor has been calibrated to provide lean air/fuel mixture characteristics and optimum fuel economy with a suitable air cleaner and exhaust system.

TAMPERING WITH EMISSION CONTROL SYSTEM PROHIBITED

Federal law and California State law prohibits the following acts or the causing thereof: (1) the removal or rendering inoperative by any person other than for purposes of maintenance, repair, or replacement, of any device or element of design incorporated into any new engine for the purpose of emission control prior to its sale or delivery to the ultimate purchaser or while it is in use, or (2) the use of the engine after such device or element of design has been removed or rendered inoperative by any person.

Among those acts presumed to constitute tampering are the acts listed below:

Do not tamper with the original emission related parts:

- Carburetor or DFI system and internal parts
- Spark plugs
- Magneto or electronic ignition system
- Fuel filter element
- Air cleaner elements
- Crankcase
- Cylinder heads
- Breather chamber and internal parts
- Intake pipe and hose

Foreword

This manual is designed primarily for use by trained mechanics in a properly equipped shop. However, it contains enough detail and basic information to make it useful to the owner who desires to perform his own basic maintenance and repair work. A basic knowledge of mechanics, the proper use of tools, and workshop procedures must be understood in order to carry out maintenance and repair satisfactorily. Whenever the owner has insufficient experience or doubts as to his ability to do the work, all adjustments, maintenance, and repair should be carried out only by qualified mechanics.

In order to perform the work efficiently and to avoid costly mistakes, read the text, thoroughly familiarize yourself with the procedures before starting work, and then do the work carefully in a clean area. Whenever special tools or equipment are specified, do not use makeshift tools or equipment. Precision measurements can only be made if the proper instruments are used, and the use of substitute tools may adversely affect safe operation.

To get the longest life out of your engine:

- Follow the Periodic Maintenance Chart in the Service Manual.
- Be alert for problems and non-scheduled maintenance.
- Use proper tools and genuine Kawasaki engine parts. Genuine parts provided as spare parts are listed in the Parts Catalog.
- Follow the procedures in this manual carefully. Don't take shortcuts.
- Remember to keep complete records of maintenance and repair with dates and any new parts installed.

How to Use This Manual

In this manual, the product is divided into its major systems and these systems make up the manual's chapters. The Quick Reference Guide shows you all of the product's system and assists in locating their chapters. Each chapter in turn has its own comprehensive Table of Contents.

For, example, if you want ignition coil information, use the Quick Reference Guide to locate

the Electrical System chapter. Then, use the Table of Contents on the first page of the chapter to find the Ignition Coil section.

Whenever you see these WARNING and CAUTION symbols, heed their instructions! Always follow safe operating and maintenance practices.

WARNING

This warning symbol identifies special instructions or procedures which, if not correctly followed, could result in personal injury, or loss of life.

CAUTION

This caution symbol identifies special instructions or procedures which, if not strictly observed, could result in damage to or destruction of equipment.

This manual contains four more symbols (in addition to WARNING and CAUTION) which will help you distinguish different types of information.

NOTE

○ *This note symbol indicates points of particular interest for more efficient and convenient operation.*

- Indicates a procedural step or work to be done.
- Indicates a procedural sub-step or how to do the work of the procedural step it follows. It also precedes the text of a WARNING, CAUTION, or NOTE.
- ★ Indicates a conditional step or what action to take based on the results of the test or inspection in the procedural step or sub-step it follows.

In most chapters an exploded view illustration of the system components follows the Table of Contents. In these illustrations you will find the instructions indicating which parts require specified tightening torque, oil, grease or a locking agent during assembly.

General Information

Table of Contents

Before Servicing	1-2
Model Identification.....	1-5
General Specifications.....	1-6

1-2 GENERAL INFORMATION

Before Servicing

Before starting to service the engine, carefully read the applicable section to eliminate unnecessary work. Photographs, diagrams, notes, cautions, warnings, and detailed descriptions have been included wherever necessary. Nevertheless, even a detailed account has limitations, a certain amount of basic knowledge is required for successful work.

Especially note the following

(1) Dirt

Before removal and disassembly, clean the engine. Any dirt entering the engine, carburetor, or other parts, will work as an abrasive and shorten the life of engine. For the same reason, before installing a new part, clean off any dust or metal filings.

(2) Battery Ground

Remove the ground (–) lead from the battery before performing any disassembly operations on the equipment. This prevents:

- (a) the possibility of accidentally turning the engine over while partially disassembled.
- (b) sparks at electrical connections which will occur when they are disconnected.
- (c) damage to electrical parts.

(3) Tightening Sequence

Generally, when installing a part with several bolts, nuts, or screws, start them all in their holes and tighten them to a snug fit. Then tighten them evenly, in a staggered sequence. This is to avoid distortion of the part and/or causing gas or oil leakage. Conversely when loosening the bolts, nuts, or screws, first loosen all of them by about a quarter of a turn and then remove them. Where there is a tightening sequence indication in this Service Manual, the bolts, nuts, or screws must be tightened in the order and method indicated.

(4) Torque

When torque values are given in this Service Manual, use them. Either too little or too much torque may lead to serious damage. Use a good quality, reliable torque wrench.

(5) Force

Common sense should dictate how much force is necessary in assembly and disassembly. If a part seems especially difficult to remove or install, stop and examine what may be causing the problem. Whenever tapping is necessary, tap lightly using a wooden or plastic-faced mallet. Use an impact driver for screws (particularly for the removal of screws held by a locking agent) in order to avoid damaging the heads.

(6) Edges

Watch for sharp edges, especially during major engine disassembly and assembly. Protect your hands with gloves or a piece of thick cloth when lifting the engine or turning it over.

(7) High-Flash Point Solvent

A high-flash point solvent is recommended to reduce fire danger. A commercial solvent commonly available in North America is Standard solvent (generic name). Always follow manufacturer and container directions regarding the use of any solvent.

(8) Gasket, O-ring

Do not reuse a gasket or O-ring once it has been in service. The mating surfaces around the gasket should be free of foreign matter and perfectly smooth to avoid oil or compression leaks.

(9) Liquid Gasket, Non-Permanent Locking Agent

Follow manufacturer's directions for cleaning and preparing surfaces where these compounds will be used. Apply sparingly. Excessive amounts may block engine oil passages and cause serious damage. An example of a non-permanent locking agent commonly available in North America is Loctite Lock'n Seal (Blue).

(10) Press

A part installed using a press or driver, such as a journal, should first be coated with oil on its outer or inner circumference so that it will go into place smoothly.

(11) Ball Bearing, Needle Bearing

Do not remove a ball bearing or a needle bearing unless it is absolutely necessary. Replace any ball or needle bearings that were removed with new ones. Install bearings with the manufacturer and size marks facing out, applying pressure evenly with a suitable driver to the end of the race that contacts the press fit portion, and press it evenly over the base component.

Before Servicing

(12)Oil Seal and Grease Seal

Replace any oil or grease seals that were removed with new ones, as removal generally damages seals.

When pressing in a seal which has manufacturer's marks, press it in with the marks facing out. Seals should be pressed into place using a suitable driver, which contacts evenly with the side of seal, until the face of the seal is even with the end of the hole.

(13)Seal Guide

A seal guide is required for certain oil or grease seals during installation to avoid damage to the seal lips. Before a shaft passes through a seal, apply a little oil, preferably high-temperature grease on the lips to reduce rubber to metal friction.

(14)Circlip, Retaining Ring and Cotter Pin

When installing circlips and retaining rings, take care to compress or expand them only enough to install them and no more. Install the circlip with its chamfered side facing load side as well.

Replace any circlips, retaining rings, and cotter pins that were removed with new ones, as removal weakens and deforms them. If old ones are reused, they could become detached while running, leading to a problem.

(15)Lubrication

Engine wear is generally at its maximum while the engine is warming up and before all the rubbing surfaces have an adequate lubricative film. During assembly, oil or grease (whichever is more suitable) should be applied to any rubbing surface which has lost its lubricative film. Old grease and dirty oil should be cleaned off. Deteriorated grease has lost its lubricative quality and may contain abrasive foreign particles.

Don't use just any oil or grease. Some oils and greases in particular should be used only in certain applications and may be harmful if used in an application for which they are not intended. This manual makes reference to molybdenum disulfide grease (MoS2) in the assembly of certain engine parts. Always check manufacturer recommendations before using such special lubricants.

(16)Electrical Wires

All the electrical wires are either single-color or two-color and, with only a few exceptions, must be connected to wires of the same color. On any of the two-color wires there is a greater amount of one color and a lesser amount of a second color, so a two-color wire is identified by first the primary color and then the secondary color. For example, a yellow wire with thin red stripes is referred to as a "yellow/red" wire; it would be a "red/yellow" wire if the colors were reversed to make red the main color.

Wire (cross-section)	Color Indicated on the Wire	Color Indicated on the Wiring Diagram
	Yellow/Red	

GB020601W1 C

(17)Replacement Parts

When there is a replacement instruction, replace these parts with new ones every time they are removed. These replacement parts will be damaged or lose their original function once removed.

(18)Inspection

When parts have been disassembled, visually inspect these parts for the following conditions or other damage. If there is any doubt as to the condition of them, replace them with new ones.

Abrasion	Crack	Hardening	Warp
Bent	Dent	Scratch	Wear
Color change	Deterioration	Seizure	

(19)Service Data

Service Data terms are defined as follows:

"Standards" show dimensions or performances which brand-new parts or systems have.

1-4 GENERAL INFORMATION

Before Servicing

“Service Limits” indicate the usable limits. If the measurement shows excessive wear or deteriorated performance, replace the damaged parts.

Model Identification

FX921V DFI, FX1000V DFI



Cylinder Number Designation:

No.1 Cylinder is the left-hand cylinder viewed from the intake pipe.

No.2 Cylinder is the right-hand cylinder viewed from the intake pipe.

1-6 GENERAL INFORMATION

General Specifications

Item	FX921V DFI, FX1000V DFI
Type of Engine	Forced air-cooled, vertical shaft, OHV 6 valves, 4-stroke gasoline engine.
Cylinder Layout	90° V-Twin
Bore x Stroke	89.15 mm x 80 mm (3.5 in. x 3.15 in.)
Piston Displacement	999 cm ³ (61 cu. in.)
Direction of Rotation	Counterclockwise facing the PTO shaft
Compression Release	Automatic compression release
Low Idle Speed	1 550 r/min (rpm)
High Idle Speed	3 600 r/min (rpm)
Ignition System	Transistorized-flywheel magneto
RFI	Per Canada and U.S.A. requirements
Starting System	Shift type electric starter
Charging System	12 V - 15 amp with regulator
Spark Plug	NGK BPR5ES
Fuel System	DFI (Digital Fuel Injection)
Air Cleaner	Dual stage element, Heavy duty type
Lubrication System	Pressure feed by positive displacement pump
Oil Filter	Cartridge type full flow filter
Oil Capacity (when engine is completely dry)	2.35 L (2.48 US-qt)
Cooling System	Forced air cooling by fan with oil cooler
Dimensions (L x W x H)	511 mm x 502 mm x 626 mm (20.12 in. x 19.76 in. x 24.65 in.)
Dry Weight (without muffler)	62.6 kg (138 lbs)

Specifications subject to change without notice.

Periodic Maintenance

Table of Contents

Periodic Maintenance Chart	2-2
Torque and Locking Agent.....	2-3
Specifications	2-5
Special Tools	2-6
Periodic Maintenance Procedures.....	2-7
Fuel System (DFI).....	2-7
Element Cleaning and Inspection	2-7
Air Cleaner Housing (Cap and Body) Inspection	2-7
Engine Top End	2-7
Cylinder Head Cleaning	2-7
Valve Clearance Inspection	2-8
Valve Clearance Adjustment.....	2-8
Valve Seat Inspection	2-9
Valve Seat Repair	2-9
Lubrication System	2-12
Engine Oil Level Inspection	2-12
Engine Oil Change.....	2-12
Oil Filter Replacement	2-13
Oil Cooler Fin Cleaning.....	2-14
Electrical System	2-14
Spark Plug Cleaning and Inspection.....	2-14
Spark Plug Gap Inspection	2-14

2-2 PERIODIC MAINTENANCE

Periodic Maintenance Chart

To ensure satisfactory operation over an extended period of time, any engine requires normal maintenance regular intervals. The Periodic Maintenance Chart below shows periodic inspection and maintenance items and suitable intervals. The bullet mark (●) designates that the corresponding item should be performed at that interval.

Some adjustments require the use of special tools or other equipment. An electronic tachometer will facilitate setting idle and running speeds.

OPERATION	INTERVAL						
	Daily	First 8 hr.	Every 100 hr.	Every 200 hr.	Every 250 hr.	Every 300 hr.	Every 500 hr.
Check and clean air intake screen	●						
Check and add engine oil	●						
Check for fuel and oil leakage	●						
Check for loose or lost nuts and screws	●						
Check battery electrolyte level	●						
Replace air cleaner primary element (1)					●		
Check air cleaner secondary element (1)					●		
Replace air cleaner secondary element (1)							●
Clean dust and dirt from cylinder and cylinder head fins (1)			●				
Tighten nuts and screws			●				
Change engine oil		●	●				
Clean and re-gap spark plugs			●				
Check and clean oil cooler fins			●				
Change oil filter				●			
◆Check and adjust valve clearance						●	
◆Clean and lap valve seating surface						●	
◆Clean combustion chamber						●	

(1): Service more frequently under dusty conditions.

◆: These items must be performed with the proper tools. See your authorized Kawasaki Engine Dealer for service, unless you have the proper equipment and mechanical proficiency.

Torque and Locking Agent

The following tables list the tightening torque for the major fasteners and the parts requiring use of a non-permanent locking agent or liquid gasket.

Letters used in the "Remarks" column mean:

EO: Apply oil to the threads.

L: Apply a non-permanent locking agent to the threads.

R: Replacement Parts

S: Tighten the fasteners following the specified sequence.

Fastener	Torque			Remarks
	N-m	kgf-m	ft-lb	
Fuel System (DFI)				
Air Cleaner Bracket Mounting Bolts	5.9	0.60	52 in-lb	
Air Cleaner Bracket Mounting Nut	19.6	2.0	14	
Air Cleaner Mounting Bracket Bolt	19.6	2.0	14	
Engine Temperature Sensor Mounting Bolt	5.9	0.60	52 in-lb	
Fuel Pump Mounting Bolt	5.9	0.60	52 in-lb	
Intake Manifold Mounting Bolts	5.9	0.60	52 in-lb	S
Intake Manifold Stud Bolts	5.9	0.60	52 in-lb	
Intake Pipe Outer Cover Mounting Bolts	5.9	0.60	52 in-lb	
Throttle Body Assy and Intake Pipe Mounting Bolts	5.9	0.60	52 in-lb	
Throttle Body Assy and Intake Pipe Mounting Nuts	5.9	0.60	52 in-lb	
Cooling System				
Cooling Fan Plate Mounting Stud Bolts	5.9	0.60	52 in-lb	
Cooling Fan Screen Bolts	5.9	0.60	52 in-lb	
Engine Shroud Bolts	5.9	0.60	52 in-lb	
Fan Housing Bolts	5.9	0.60	52 in-lb	
Guard Mounting Bolts	5.9	0.60	52 in-lb	
Engine Top End				
Connecting Rod Big End Cap Bolts	20.6	2.10	15.2	EO
Cylinder Head Bolts	46	4.7	34	S
Engine Temperature Sensor Lead Clamp Bolt	19.6	2.0	14	
Exhaust Pipe Nuts	22	2.2	16	
Rocker Cover Bolts	5.9	0.60	52 in-lb	
Spark Plugs	22	2.2	16	
Valve Clearance Adjusting Locknuts	9.8	1.0	87 in-lb	
Lubrication System				
Engine Oil Drain Plugs	6.9	0.70	61 in-lb	EO
Oil Cooler Bolts	5.9	0.60	52 in-lb	
Oil Filler Mounting Bolt	5.9	0.60	52 in-lb	
Oil Filter	11.8	1.20	104 in-lb	R
Oil Filter Joint Pipe	6.9	0.70	61 in-lb	
Oil Pump Cover Plate Bolts	5.9	0.60	52 in-lb	
Camshaft/Crankshaft				
Breather Chamber Cover Bolts	5.9	0.60	52 in-lb	
Breather Pipe Cover Bolts	5.9	0.60	52 in-lb	
Breather Valve Mounting Screws	2.0	0.20	18 in-lb	
Connecting Rod Big End Cap Bolts	20.6	2.10	15.2	EO

2-4 PERIODIC MAINTENANCE

Torque and Locking Agent

Fastener	Torque			Remarks
	N·m	kgf·m	ft·lb	
Crankcase Cover Bolts	46	4.7	34	S
Crankcase Cover Oil Passage Plugs	3.9	0.40	35 in·lb	L
Crankcase Oil Passage Plugs	3.9	0.40	35 in·lb	L
Starter System				
Starter Motor Mounting Bolts	19.6	2.0	14	
Starter Motor Terminal Nut	8.8	0.90	78 in·lb	
Electrical System				
Crankshaft Position Sensor Mounting Bolt	5.9	0.60	52 in·lb	
Engine Ground Terminal Bolt	5.9	0.60	52 in·lb	
Flywheel Bolt	56	5.7	41	
Ignition Coil Bolts	7.0	0.71	62 in·lb	
Ignition Coil Bracket Bolts	5.9	0.60	52 in·lb	
Regulator Screws	3.5	0.36	31 in·lb	
Spark Plugs	22	2.2	16	
Stator Coil Screws	3.4	0.35	30 in·lb	

The table below, relating tightening torque to thread diameter, lists the basic torque for the bolts and nuts. Use this table for only the bolts and nuts which do not require a specific torque value. All of the values are for use with dry solvent-cleaned threads.

Basic Torque for General Fasteners

Threads dia (mm)	Torque		
	N·m	kgf·m	ft·lb
4	2.0	0.20	17 in·lb
5	3.4	0.35	30 in·lb
6	5.9	0.60	52 in·lb
8	15	1.5	11

Specifications

Item	Standard
Fuel System (DFI) Idle Speed: (1) Low Idle Speed High Idle Speed Air Cleaner: Type Pre-cleaner Second-stage cleaner	 1 550 r/min (rpm) (for reference) 3 600 r/min (rpm) (for reference) Heavy duty type Primary element Secondary element
Engine Top End Valve Clearance: Intake, Exhaust Valve Seating Surface Angle: Intake, Exhaust Valve Seating Surface Width: Exhaust Intake	 0.10 ~ 0.15 mm (0.004 ~ 0.006 in.) 45° 1.0 ~ 1.5 mm (0.039 ~ 0.059 in.) 0.7 ~ 1.1 mm (0.028 ~ 0.043 in.)
Lubrication System Engine Oil: Type Viscosity Capacity Level	 SF, SG, SH, SJ or SL class SAE 40, SAE 30, SAE 10W-30/SAE 10W-40, or SAE 5W-20 1.7 L (1.8 US qt) (When filter is not removed) 1.9 L (2.0 US qt) (When filter is removed) Operating range (grid area (ADD and FULL)) on dipstick
Electrical System Spark Plug Spark Plug Gap	 NGK BPR5ES 0.7 ~ 0.8 mm (0.028 ~ 0.031 in.)

(1) Idle speeds may vary depending on each equipment. Refer to the equipment specification.

2-6 PERIODIC MAINTENANCE

Special Tools

Valve Seat Cutter, 45° - $\phi 27.5$:

57001-1114

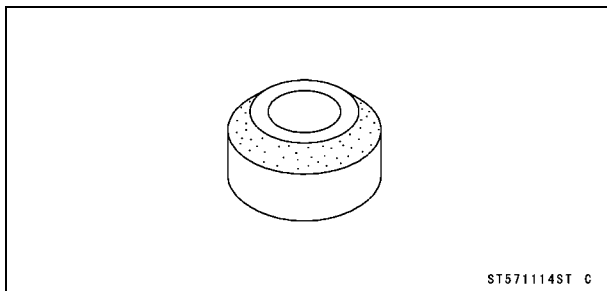

Valve Seat Cutter Holder Bar:

57001-1128

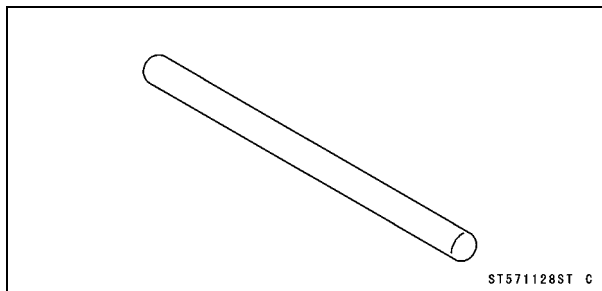

Valve Seat Cutter, 45° - $\phi 32$:

57001-1115

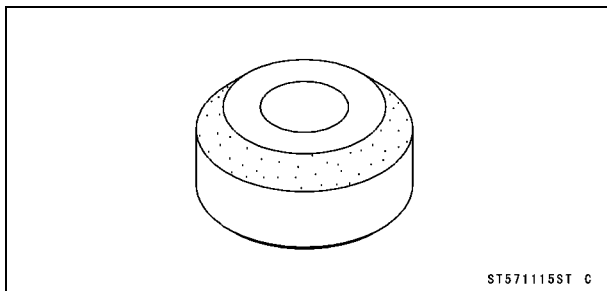

Valve Seat Cutter, 32° - $\phi 33$:

57001-1199

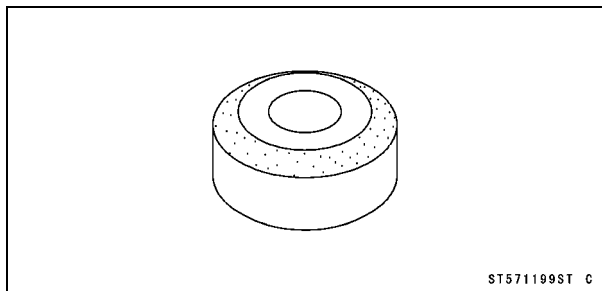

Valve Seat Cutter, 32° - $\phi 28$:

57001-1119

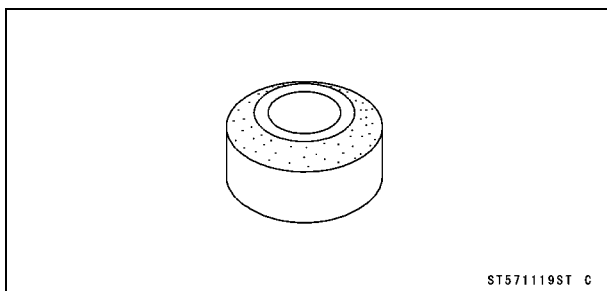

Oil Filter Wrench:

57001-1249

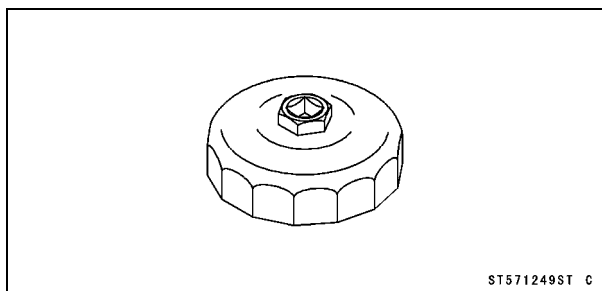

Valve Seat Cutter Holder, $\phi 7$:

57001-1126

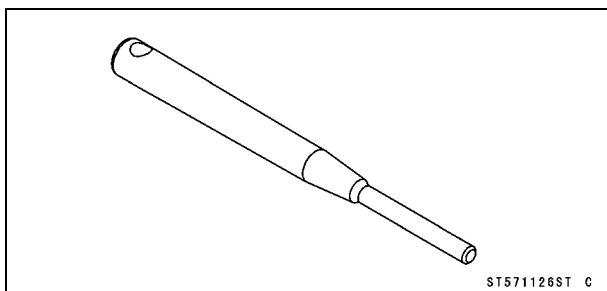

Valve Seat Cutter Holder, $\phi 6$:

57001-1360

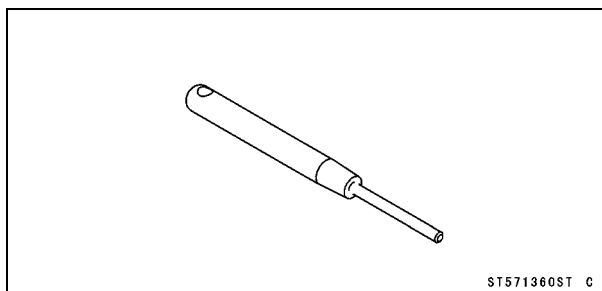

Periodic Maintenance Procedures

Fuel System (DFI)

Element Cleaning and Inspection

Air cleaner elements are not recommended to be cleaned, and each air cleaner element should be replaced with new ones at the maintenance time as shown in the maintenance chart.

NOTE

○ *Operating in dusty condition may require more frequent maintenance than above.*

- Remove the elements (see Element Removal in the Fuel System chapter).
- Replace the primary element [A] every 250 hrs.
- Replace the secondary element [A] with a new one if dirty when primary element is checked.
- Replace the secondary element every 500 hrs.

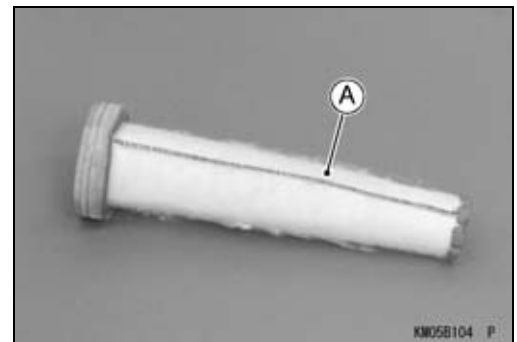
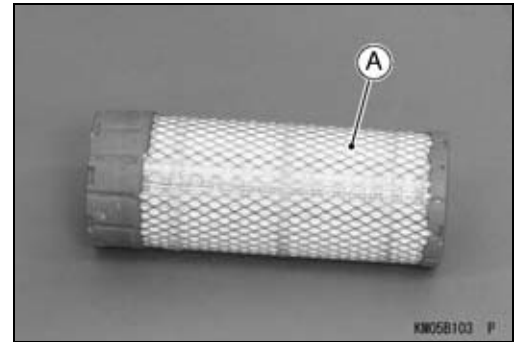

CAUTION

Do not wash air cleaner elements. Do not oil air cleaner elements. Do not use pressurized air to clean air cleaner elements.

Air Cleaner Housing (Cap and Body) Inspection

- Remove:
 - Elements (see Element Removal in the Fuel System chapter)
 - Air Cleaner Housing (see Air Cleaner Body and Bracket Removal in the Fuel System chapter)
- Clean the housing with detergent and water and dry the housing thoroughly.
- Check the housing for deformation or other damage.
- Seal the housing well and permit only filtered air to reach the throttle body assy.
- ★ If the housing is damaged, replace the housing with a new one.
- Check that no foreign material is obstructing the air passage.

Engine Top End

Cylinder Head Cleaning

- Scrape the carbon deposits from the cylinder head and the exhaust port with a suitable tool [A].
- To avoid gouging, use scrapers that are made of a material that will not cause damage.
- Clean the head in a bath of high-flash point solvent and dry it with compressed air.

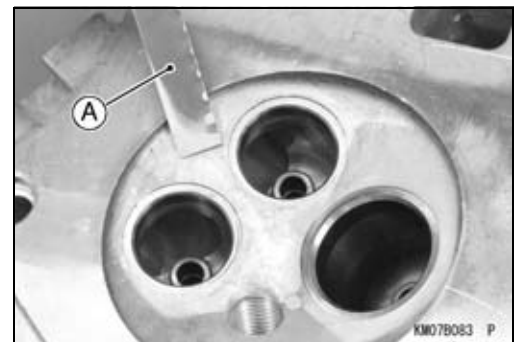

⚠ WARNING

Clean the cylinder head in a well-ventilated area, and take care that there are no sparks or flame anywhere near the working area; this includes any appliance with a pilot light. Do not use gasoline or a low-flash point solvent to clean the cylinder head. A fire or explosion could result.

2-8 PERIODIC MAINTENANCE

Periodic Maintenance Procedures

Valve Clearance Inspection

NOTE

○ Valve clearance must be checked when the engine is cold (at room temperature).

- Remove the rocker covers (see Cylinder Head Assembly Removal in the Engine Top End chapter).
- Place the piston at the top dead center (T.D.C) of the compression stroke by turning the crankshaft clockwise facing the flywheel.

No.1 Cylinder:

- Set the gap [A] of the flywheel [B] as shown in the figure.
- Check the intake and exhaust valves are closed completely, if they are not closed, turn the flywheel one turn (360°) clockwise and set the gap of the flywheel as shown in the figure again.

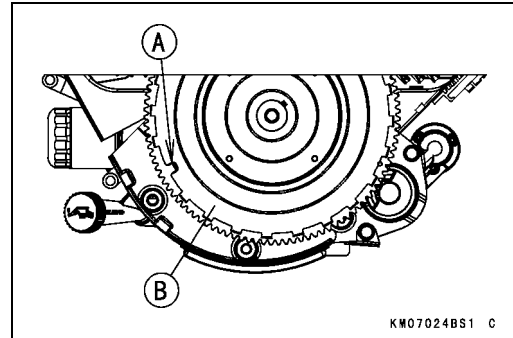

No.2 Cylinder:

- Set the gap [A] of the flywheel [B] as shown in the figure. Follow No.1 Cylinder alignment.

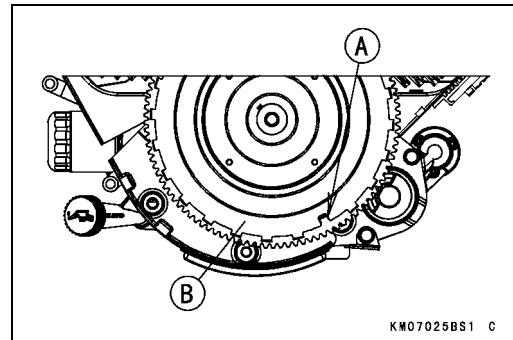

- Then check the valve clearance.
- Using a thickness gauge [A], measure the valve clearance between the rocker arm [B] and the valve stem end.
- ★ If the valve clearance is incorrect, adjust it.

Valve Clearance (when cold)

Intake, Exhaust 0.10 ~ 0.15 mm (0.004 ~ 0.006 in.)

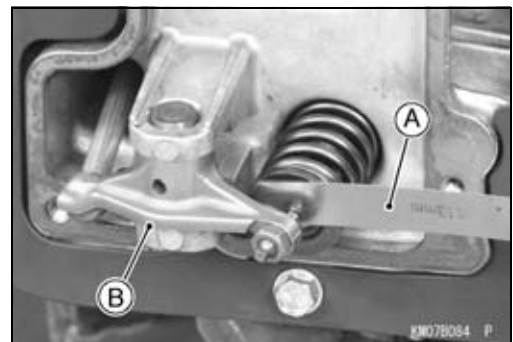

Valve Clearance Adjustment

- Since valve repairs change the valve clearance, adjust the valve clearance to the specified.
- Turn the crankshaft in proper direction until the piston is at the TDC of the compression stroke (as described above).
- Loosen the adjusting screw [A] with a suitable tool [B].
- Loosen the valve clearance adjusting locknut [C].
- Insert a 0.10 mm (0.004 in.) thickness gauge [D] between the rocker arm and valve stem end. Tighten the adjusting screw until the thickness gauge begins to bind between the rocker arm and valve stem end. Sweep the thickness gauge during this adjustment.

Valve Clearance (when cold)

Intake, Exhaust 0.10 ~ 0.15 mm (0.004 ~ 0.006 in.)

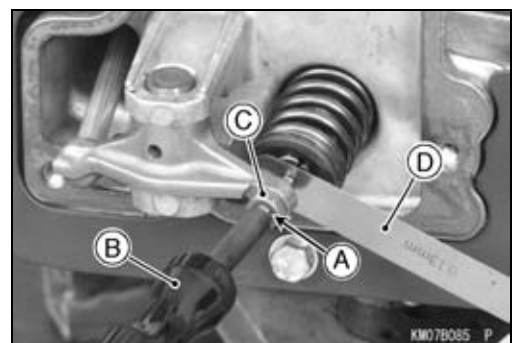

Periodic Maintenance Procedures

- Holding the adjusting screw with a suitable tool, tighten the adjusting locknut [A] to the specified torque.

Torque - Valve Clearance Adjusting Locknuts: 9.8 N·m (1.0 kgf·m, 87 in·lb)

- Do not overtighten the valve clearance adjusting locknuts.
- After the valve clearance adjustment, measure the valve clearance again. Readjust the valve clearance if necessary.

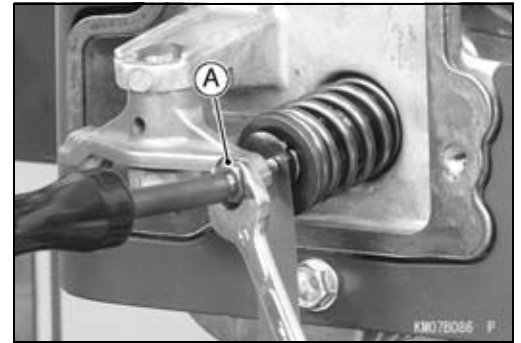

Valve Seat Inspection

- Remove the valve (see Valve Mechanism Removal/Installation in the Engine Top End chapter).
- Inspect the valve seats for damage.
- ★ If the seats are warped or distorted beyond reconditioning, replace the cylinder head with a new one.
- Pitted or worn valve seats can be refaced. Lap the valves to the seats after refacing.
- Coat the valve seat with machinist's dye.
- Push the valve into the guide.
- Rotate the valve against the seat with a lapping tool.
- Pull the valve out, and check the seating pattern on the valve head. It must be the correct width [A] and even all the way around.

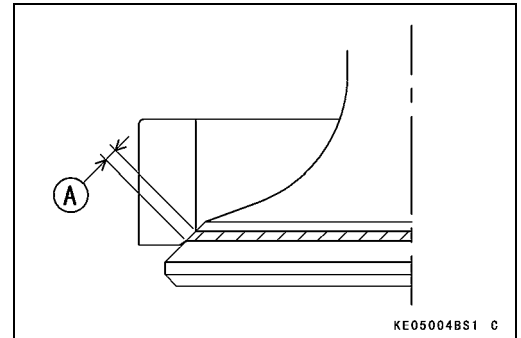

NOTE

○ The valve stem and guide must be in good condition or this check will not be valid.

Good [A]
 Too Wide [B]
 Too Narrow [C]
 Uneven [D]

- ★ If the valve seating pattern is not correct, repair the seat.

Valve Seating Surface Width (STD)

Exhaust	1.0~ 1.5 mm (0.039 ~ 0.059 in.)
Intake	0.7 ~ 1.1 mm (0.028 ~ 0.043 in.)

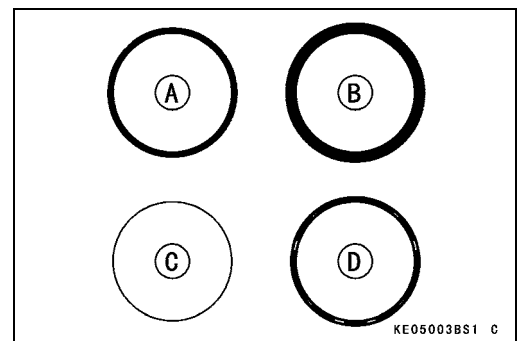

Valve Seat Repair

- Follow the manufacturer's instructions for use of valve seat cutters.

Special Tools - Valve Seat Cutter Holder Bar: 57001-1128

Exhaust Valve

Valve Seat Cutter, 45° - ϕ 32: 57001-1115
 Valve Seat Cutter, 32° - ϕ 33: 57001-1199
 Valve Seat Cutter Holder, ϕ 7: 57001-1126

Intake Valve

Valve Seat Cutter, 45° - ϕ 27.5: 57001-1114
 Valve Seat Cutter, 32° - ϕ 28: 57001-1119
 Valve Seat Cutter Holder, ϕ 6: 57001-1360

- ★ If the manufacturer's instructions are not available, use the following procedure.

2-10 PERIODIC MAINTENANCE

Periodic Maintenance Procedures

Seat Cutter Operating Cares

1. This valve seat cutter is designed only for valve seat repair. Therefore the cutter must not be used for other purposes.
2. Do not drop or hit the valve seat cutter, or the diamond particles may fall off.
3. Do not fail to apply engine oil to the valve seat cutter before grinding the seat surface. Also wash off ground particles sticking to the cutter with washing oil.

NOTE

○Do not use a wire brush to remove the metal particles from the cutter. It will take off the diamond particles.

4. Setting the valve seat cutter holder [A] in position, operate the cutter [B] with one hand [C]. Do not apply too much force to the diamond portion.

NOTE

○Prior to grinding, apply engine oil to the cutter, and during the operation wash off any ground particles sticking to the cutter with washing oil.

5. After use wash the cutter with washing oil and apply a thin layer of engine oil before storing.

Marks Stamped on the Cutter

The marks stamped on the back of the cutter represent the following.

32°	Cutter angle [A]
37.5	Cutter diameter [B]
KS8B	Manufactured lot number

Operating Procedures

- Clean the seat area carefully.
- Recondition the valve seats with the valve seat cutters (45°, 32°) and lap the valves.
- Check the seats for good contact all the way around with machinist's dye.
- Measure the seat width [A]. If it is more than the standard width, the seating surface should be refaced.
- ★ If the valve seating pattern is not correct, repair the seat.

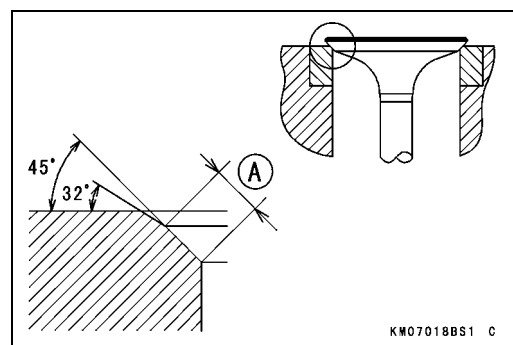
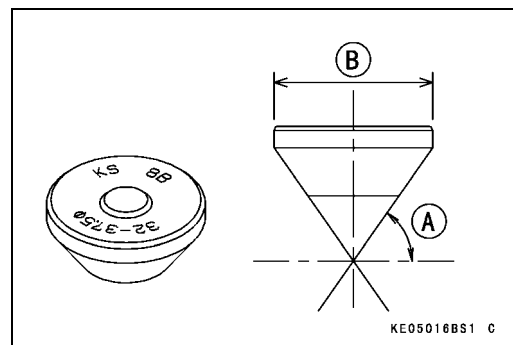
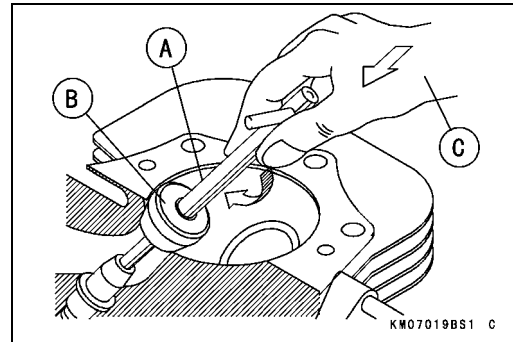

Periodic Maintenance Procedures

- Coat the seat with machinist's dye.
- Fit a 45° cutter [A] to the holder and slide it into the valve guide.
- Resurface the valve seat with a 45° cutter, removing only enough material to produce a smooth and concentric seat.

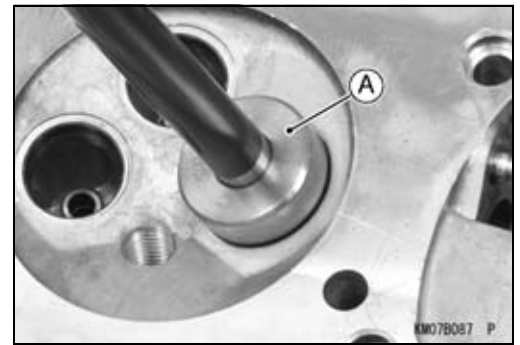

CAUTION

Do not grind the seat too much. Overgrinding will reduce valve clearance by sinking the valve into the head. If the valve sinks too far into the head, it will be impossible to adjust the clearance, and the cylinder head must be replaced. Do not turn the cutter counterclockwise or drop it against the seat, or it will be dulled.

- Use a 32° seat cutter [A] to narrow the seat width to the standard width.
- Turn the seat cutter one turn at a time while pressing down very lightly. Check the seat width after each turn.

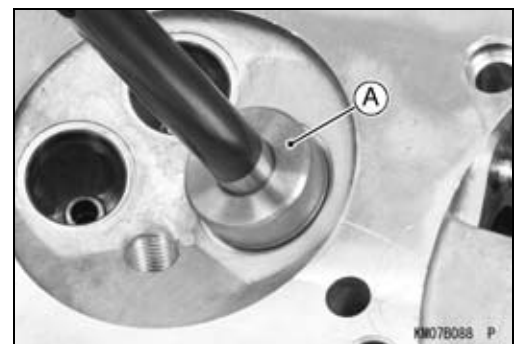

CAUTION

The 32° cutter removes material very quickly. Check the seat width frequently to prevent over grinding.

NOTE

- *Keep the seat width as close as possible to the standard width.*
- Make a light contact on the valve seat with the 45° cutter to remove any possible burrs at the edge of the seat.
- After resurfacing the seat, inspect for even valve seating.
- Apply a machinist's dye to the valve face, insert the valve, and snap it closed against the seat several times. The valve surface should show good contact all the way around. Be sure the valve seat is centered on the valve face. The position of the valve in the seat is evident after lapping the valve.
- ★ If the seat does not make proper contact, lap the valve into seat with a lapper.
- Coat the face of valve sparingly with a fine lapping compound.
- Use the lapper tool [A], to grip the top of the valve [B]. Rotate the valve in a circular motion to lap the valve to the seat.
- Lift the valve slightly from the seat every 8 to 10 strokes, continue lapping operation until a uniform ring appears around entire surface of the valve face.

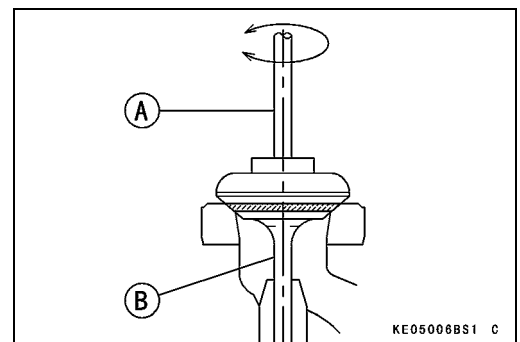

2-12 PERIODIC MAINTENANCE

Periodic Maintenance Procedures

- When lapping is completed, wash all parts in solvent to remove lapping compound. Dry the parts thoroughly.
- Note the position of the lapping mark on the valve face. The lapping mark should appear on or near the center of the valve face.
- When the engine is assembled, be sure to adjust the valve clearances (see Valve Clearance Adjustment).

Lubrication System

Engine Oil Level Inspection

- Place the engine on a level surface.
- Remove the oil filler cap [A] and wipe its dipstick [B] with a clean cloth.
- Insert the dipstick into tube [C] without screwing it in, then check the oil level.
- The oil level should be the operating range (grid area) [D] on the dipstick.
- ★ If the oil level is "ADD" range [E], add enough engine oil to bring oil level to the operating range.

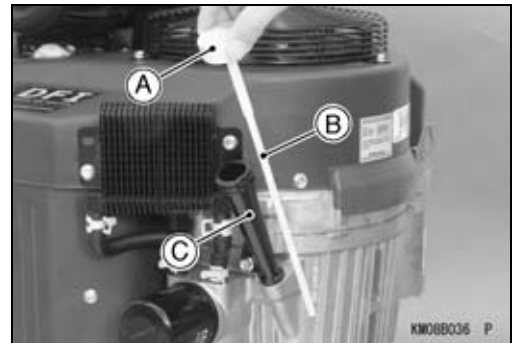

CAUTION

Do not add more oil above the operating range. Excess oil will cause a smoking condition.

- Use the same type and make of oil that is already in the engine.

NOTE

○ If the engine oil type and make are unknown, use any brand of the specified oil to top up the level in preference to running the engine with the oil level low. Then at your earliest convenience, change the oil completely.

- ★ If the oil level is "FULL" range [F], drain the excess oil by loosening the drain plug.

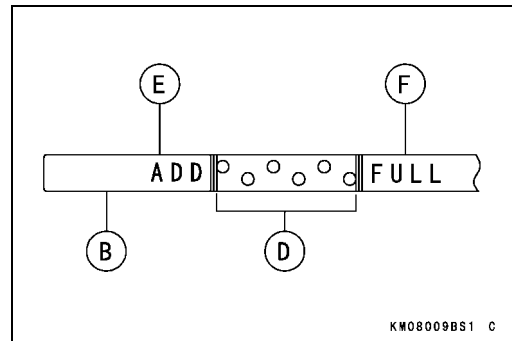

Engine Oil Change

- Change the oil after first 8 hours of operation. Thereafter change oil every 100 hours.
- Start and warm up the engine to drain the oil easily.
- Stop the engine.
- Place the engine on a level surface.
- Place a suitable container under the engine.
- Remove the oil drain plug [A] and drain the oil.

WARNING

Be careful of hot oil when draining. It may be hot enough to burn you severely.

- Replace the O-ring [B] with a new one.
- Apply grease to the O-rings.
- Install the oil drain plugs with the O-rings and tighten them.

Torque - Engine Oil Drain Plugs: 6.9 N·m (0.70 kgf·m, 61 in·lb)

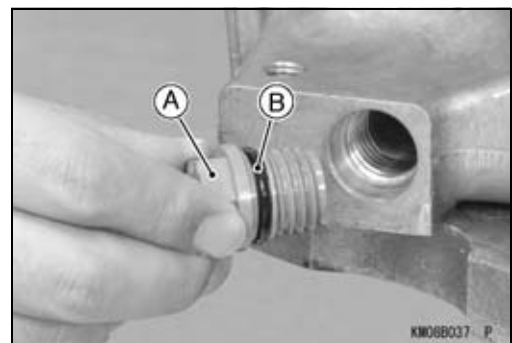

Periodic Maintenance Procedures

- Remove the oil filler cap and pour in the specified type and the amount of oil.

Engine Oil:

Grade: SF, SG, SH, SJ or SL Class

Viscosity: SAE40, SAE30, SAE10W-30/SAE10W-40, or SAE5W-20

Capacity: [When the oil filter is not removed]
 1.7 L (1.8 US qt)
 [When the oil filter is removed]
 1.9 L (2.0 US qt)

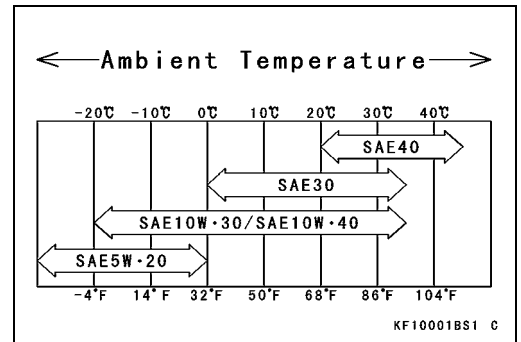

- Check the O-ring [A] on the oil filler cap for damage. Replace the oil filler cap with a new one if O-ring is damaged.
- ★ When checking the oil level, do not turn oil filler cap on threads.

NOTE

○ Some increase in oil consumption may be expected when a multi grade engine oil (10W-30/10W-40, 5W-20) is used. Check the oil level more frequently than recommended interval.

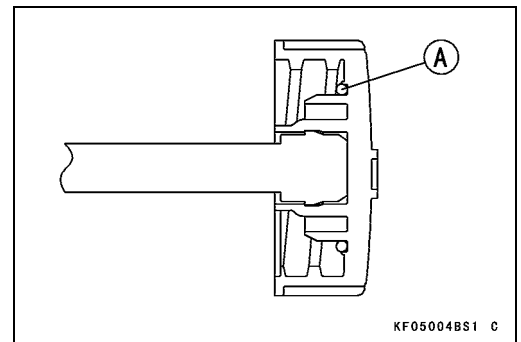

Oil Filter Replacement

- Drain the engine oil (see Engine Oil Change).
- Remove the oil filter [A] with the oil filter wrench [B] or strap wrench.

Special Tool - Oil Filter Wrench: 57001-1249

- When unscrewing the oil filter, place a suitable container beneath the oil drip tray to receive oil from the oil filter and oil passages in the engine.

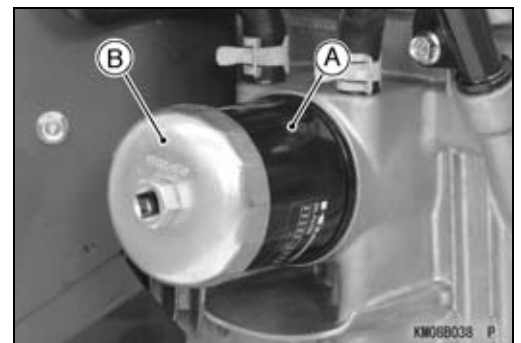

- Replace the oil filter [A] with a new one.
- Apply light film of engine oil to the seal [B].
- Install the oil filter.

Torque - Oil Filter: 11.8 N·m (1.2 kgf·m, 104 in·lb)

- Turn the filter until the seal contacts mounting surface [C] of the engine. Then turn the filter BY HAND (S) 2/3 turn.
- Run the engine at slow idle speed for 3 minutes.
- While running the engine, check for oil leaks around it.
- Stop the engine and check the oil level (see Engine Oil Level Inspection).

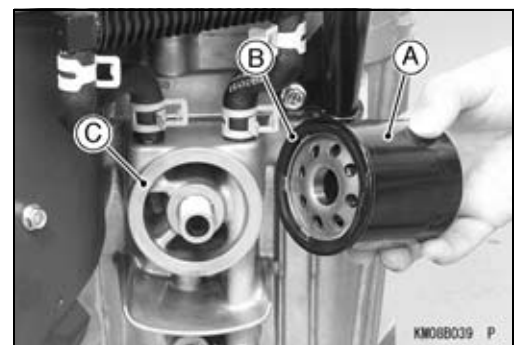

2-14 PERIODIC MAINTENANCE

Periodic Maintenance Procedures

Oil Cooler Fin Cleaning

- Clean dirt off the outside fins [A] with brush or with compressed air.

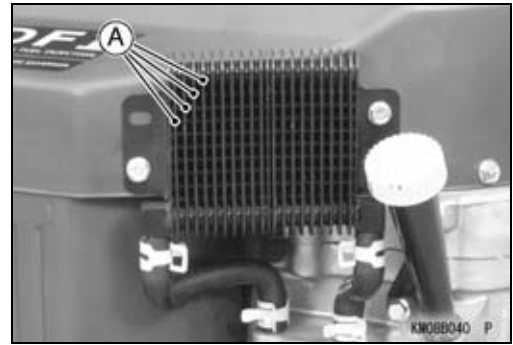

Electrical System

Spark Plug Cleaning and Inspection

- Remove the spark plug (see Spark Plug Removal in the Electrical System chapter).
- ★ If the plug is oily or has carbon built up on it, clean the plug using a high-flash point solvent and a wire brush or other suitable tools.
- ★ If the spark plug electrodes are corroded or damaged, or if the insulator is cracked, replace the plug with a new one. Use the standard spark plug or its equivalent.

- Insulator [A]
- Center Electrode [B]
- Plug Gap [C]
- Side Electrode [D]

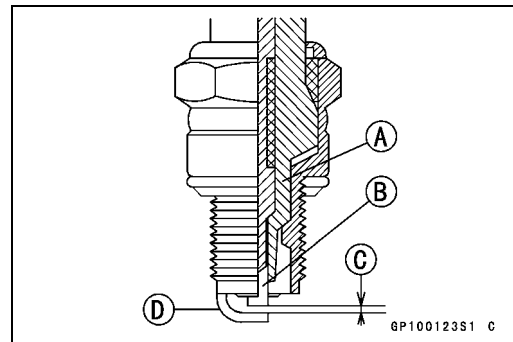

Spark Plug Gap Inspection

- Measure the gap with a wire-type thickness gauge.
- ★ If the gap is incorrect, carefully bend the side electrode with a suitable tool to obtain the correct gap.

Spark Plug Gap

Standard: 0.7 ~ 0.8 mm (0.028 ~ 0.031 in.)

Fuel System (DFI)

Table of Contents

Exploded View	3-2	Fuel Injector Installation	3-17
Specifications	3-4	Audible Inspection.....	3-18
Throttle Body Assy	3-5	Fuel Injector Resistance	
Intake Pipe Removal.....	3-5	Inspection.....	3-18
Intake Pipe Installation.....	3-5	Fuel Pump (Fault Code 45)	3-19
Throttle Body Assy Removal.....	3-6	Fuel Pump Removal	3-19
Throttle Body Assy Installation.....	3-7	Fuel Pump Installation	3-19
Intake Manifold	3-8	Fuel Pump Resistance Inspection	3-19
Intake Manifold Removal	3-8	Battery Voltage (Fault Code 97)...	3-19
Intake Manifold Installation	3-8	Throttle (Accelerator) Position	
Intake Manifold Inspection	3-8	Sensor (Fault Code 11) (Models	
Digital Fuel Injection (DFI) System	3-9	except for FXT00V-AS01).....	3-19
DFI System	3-9	Ignition Coil (Fault Code 51,	
DFI System Wiring Diagram	3-10	52) (Models except for	
Terminal Numbers of ECU		FXT00V-AS01).....	3-20
Connectors.....	3-11	Ignition Coil Removal/Installation.	3-20
Safety Instruction for DFI System		Ignition Coil Inspection.....	3-20
Servicing	3-11	Ignition Coil Wiring Continuity	
Electrical System	3-11	Inspection.....	3-20
Fuel System	3-12	Throttle Motor (Fault Code	
Air System.....	3-12	58) (Models except for	
Wiring Inspection	3-12	FXT00V-AS01).....	3-21
ECU Connector Inspection	3-13	Throttle Motor Removal/Adjust-	
Self-Diagnosis.....	3-13	ment	3-21
Self-diagnosis Outline	3-13	Throttle Motor Wiring Continuity	
Self-diagnosis Procedures.....	3-13	Inspection.....	3-21
Model Identification	3-13	Governor Motor (Fault Code 11)	
How to Read Fault Codes.....	3-14	(FXT00V-AS01)	3-22
Map Sensor (Fault Code 12)	3-15	Governor Motor Removal/Adjust-	
Engine Temperature Sensor (Fault		ment	3-22
Code 17)	3-15	Governor Motor Wiring Continuity	
Engine Temperature Sensor		Inspection.....	3-22
Removal.....	3-15	Throttle (Accelerator) Position	
Engine Temperature Sensor		Sensor (Fault Code 18)	
Installation.....	3-16	(FXT00V-AS01)	3-22
Engine Temperature Sensor		Fuel Filter.....	3-23
Resistance Inspection.....	3-16	Fuel Filter Removal/Installation....	3-23
Crankshaft Position Sensor (Fault		Fuel Filter Inspection.....	3-23
Code 21)	3-16	Air Cleaner.....	3-24
Crankshaft Position Sensor		Element Removal.....	3-24
Removal.....	3-16	Element Installation.....	3-24
Crankshaft Position Sensor		Element Cleaning and Inspection	3-25
Installation.....	3-16	Air Cleaner Body and Bracket	
Crankshaft Position Sensor		Removal.....	3-25
Inspection.....	3-17	Air Cleaner Body and Bracket	
Fuel Injectors #1, #2 (Fault Code		Installation	3-25
41, 42).....	3-17	Air Cleaner Housing (Cap and	
Fuel Injector Removal.....	3-17	Body) Inspection	3-26

3-2 FUEL SYSTEM (DFI)

Exploded View

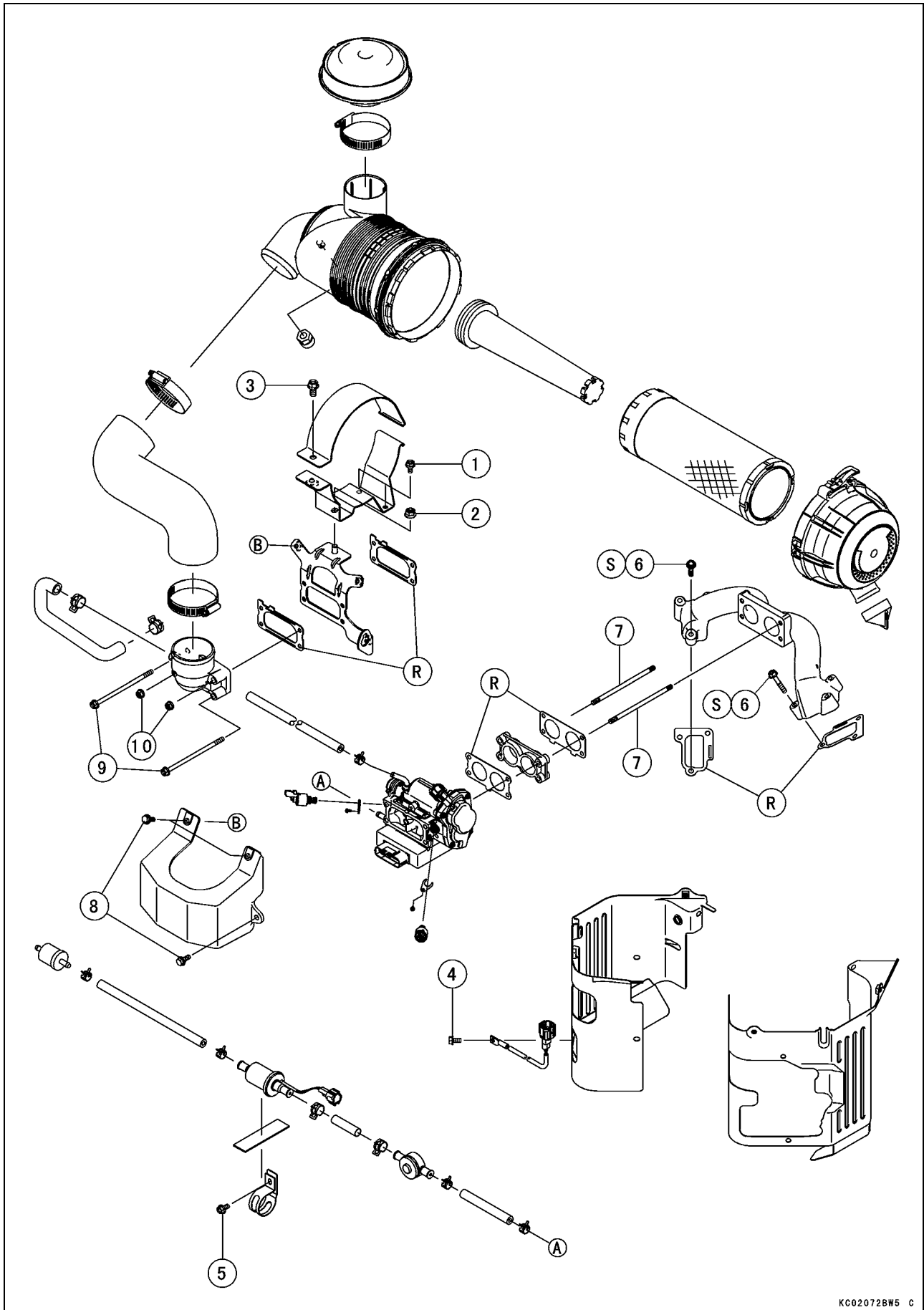

Exploded View

No.	Fastener	Torque			Remarks
		N·m	kg·m	ft·lb	
1	Air Cleaner Bracket Mounting Bolts	5.9	0.60	52 in·lb	
2	Air Cleaner Bracket Mounting Nut	19.6	2.0	14	
3	Air Cleaner Mounting Bracket Bolt	19.6	2.0	14	
4	Engine Temperature Sensor Mounting Bolt	5.9	0.60	52 in·lb	
5	Fuel Pump Mounting Bolt	5.9	0.60	52 in·lb	
6	Intake Manifold Mounting Bolts	5.9	0.60	52 in·lb	S
7	Intake Manifold Stud Bolts	5.9	0.60	52 in·lb	
8	Intake Pipe Outer Cover Mounting Bolts	5.9	0.60	52 in·lb	
9	Throttle Body Assy and Intake Pipe Mounting Bolts	5.9	0.60	52 in·lb	
10	Throttle Body Assy and Intake Pipe Mounting Nuts	5.9	0.60	52 in·lb	

R: Replacement Parts

S: Tighten the fasteners following the specified sequence.

3-4 FUEL SYSTEM (DFI)

Specifications

Item	Standard
Digital Fuel Injection System	
Throttle Body Assy:	
Type	Two barrel type
Bore	$\phi 28$ mm (1.1 in.)
Engine Temperature Sensor:	
Resistance	10 k Ω at 25°C (77°F)
Fuel Injectors:	
Nozzle Type	Fine atomizing type with 1 hole
Resistance	23.5 \pm 1 Ω at 25°C (77°F)
Fuel Pump:	
Resistance	3.5 Ω at 20°C (68°F)
Idle Speed (1)	
Low Idle Speed	1 550 r/min (rpm) (for reference)
High Idle Speed	3 600 r/min (rpm) (for reference)
Air Cleaner	
Type	Heavy duty type
Pre-cleaner	Primary element
Second-stage cleaner	Secondary element
Fuel (2)	
Fuel Requirement	Unleaded regular grade gasoline
US, Canada	Using a minimum of 87 octane by antiknock index is recommended. Antiknock Index: (RON + MON)/2 RON = Research Octane Number MON = Motor Octane Number
Other Countries	Using a minimum of 91 octane by RON is recommended.

(1) Idle speeds may vary depending on each equipment. Refer to the equipment specification.

(2) Other fuel requirements:

See Fuel and oil recommendations in Owner's Manual.

Throttle Body Assy

Intake Pipe Removal

- Remove:
 - Air Cleaner (see Air Cleaner Body and Bracket Removal)
 - Bolts [A]
 - Intake Pipe Outer Cover [B]

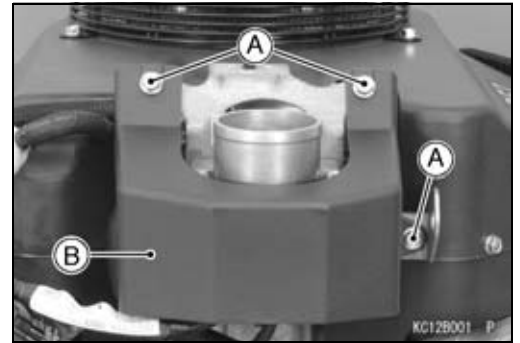

- Remove:
 - Clamp [A]
 - Breather Hose [B]
 - Nuts [C]
 - Bolts [D]
 - Intake Pipe [E] and Gasket

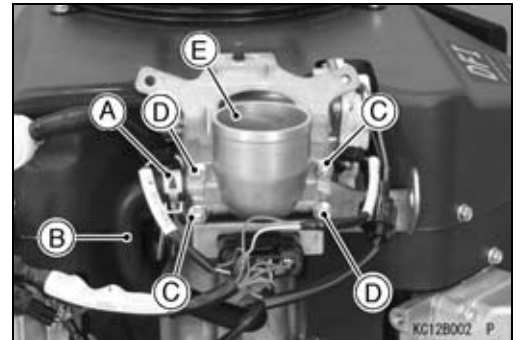

Intake Pipe Installation

- Replace the gasket [A] with a new one.
- Install:
 - Gasket
 - Intake Pipe [B]
- Tighten:
 - Torque - Throttle Body Assy and Intake Pipe Mounting Bolts [C]: 5.9 N·m (0.60 kgf·m, 52 in·lb)**
 - Throttle Body Assy and Intake Pipe Mounting Nuts [D]: 5.9 N·m (0.60 kgf·m, 52 in·lb)**

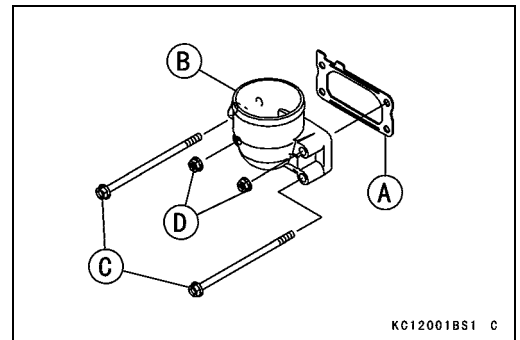

- Connect the breather hose [A] so that the clamp knob [B] faces the downward.



- Install the intake pipe outer cover [A].
- Tighten:
 - Torque - Intake Pipe Outer Cover Mounting Bolts [B]: 5.9 N·m (0.60 kgf·m, 52 in·lb)**

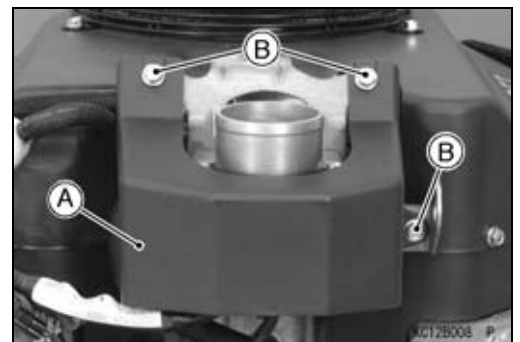

- Install the removed parts (see appropriate chapters).

3-6 FUEL SYSTEM (DFI)

Throttle Body Assy

Throttle Body Assy Removal

⚠ WARNING

Gasoline is extremely flammable and can be explosive under certain conditions. Turn the ignition switch OFF. Do not smoke. Make sure the area is well-ventilated and free from any source of flame or sparks; this includes any appliance with a pilot light.

CAUTION

Never drop the throttle body assy, especially on a hard surface.
Such a shock to the throttle body assy can damage the ECU.

- Remove the intake pipe (see Intake Pipe Removal).
- Disconnect:
 - ECU Connector [A]
 - Injector Connectors [B]
 - Governor (Throttle) Motor Connector [C]
- Remove the control panel [D] and gasket.

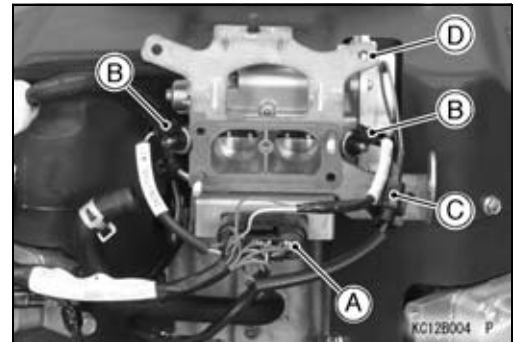

- Remove:
 - Clamp [A]
 - Fuel Hose [B]
 - Throttle Body Assy [C]
 - Gaskets and Insulator

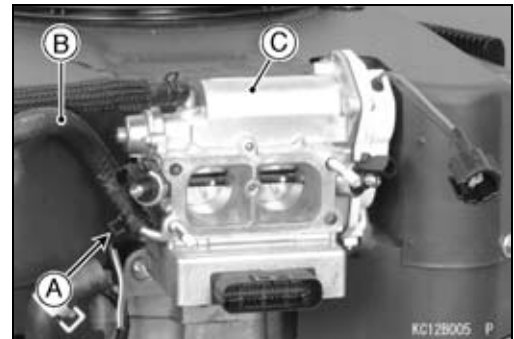

Throttle Body Assy

Throttle Body Assy Installation

- Clean the mating surface of the throttle body assy and intake manifold.
- Replace the gaskets [A] with new ones.
- Install the insulator [B], throttle body assy [C] and new gaskets sequence as shown in the figure.

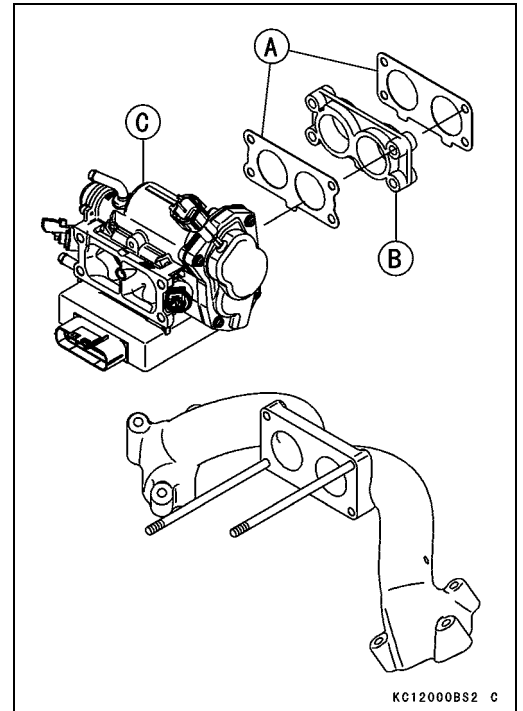

- Install the fuel hose [A] fully so that the clamp knob [B] face horizontal direction.

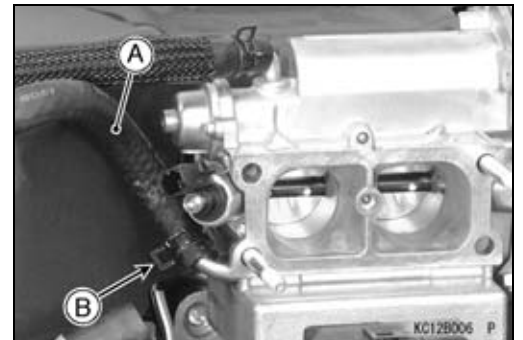

- Install the control panel [A].
- Connect:
 - Governor (Throttle) Motor Connector [B]
 - Injector Connector #1 [C]
 - Injector Connector #2 [D]
 - ECU Connector [E]
- Install the removed parts (see appropriate chapters).

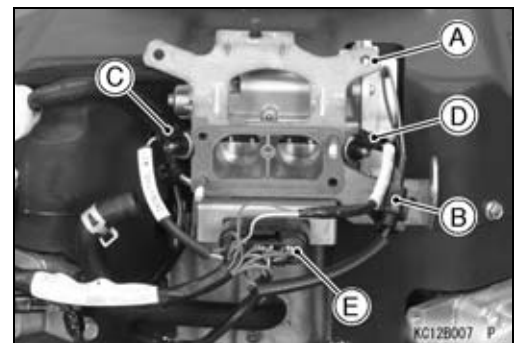

3-8 FUEL SYSTEM (DFI)

Intake Manifold

Intake Manifold Removal

- Remove:
 - Fan Housing (see Flywheel and Stator Coil Removal in the Electrical System chapter)
 - Throttle Body Assy (see Throttle Body Assy Removal)
- Cut off the bands [A] holding the wire lead and/or harness.
- Unscrew the intake manifold bolts in the order shown [1 to 6].
- Remove the intake manifold [B] and gaskets.

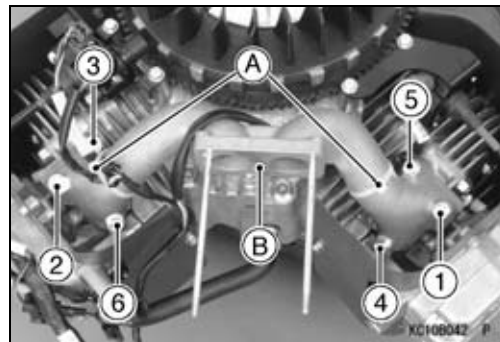

Intake Manifold Installation

- Replace the intake manifold gaskets [A] with new ones.
- Clean the mating surfaces of the cylinders and intake manifolds.
- Install the intake manifold gaskets so that the hole [B] of the gaskets fit the projection [C] of the cylinder head.
- Install the intake manifold.

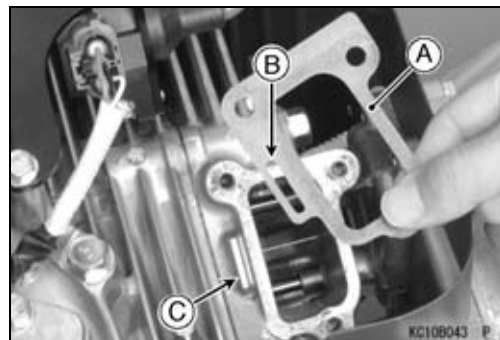

- Tighten the intake manifold mounting bolts following the tightening sequence.

Torque - Intake Manifold Mounting Bolts: 5.9 N·m (0.60 kgf·m, 52 in·lb)

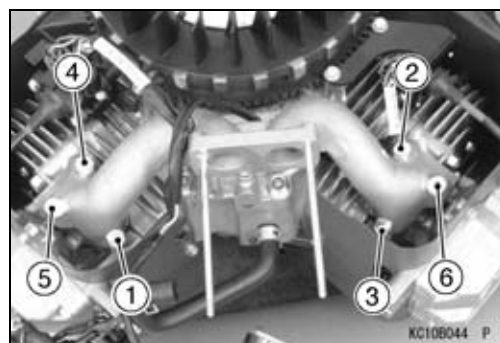

- Fix the wire lead and the harness to the intake manifold [A] with bands [B].
- Position the wire lead and/or harness on top of the intake manifold as shown in the figure.
 - Approx. 38 mm (1.5 in.) [C]
 - Approx. 85 mm (3.3 in.) [D]
- Cut excess the band off.
- Install the removed parts (see appropriate chapters).

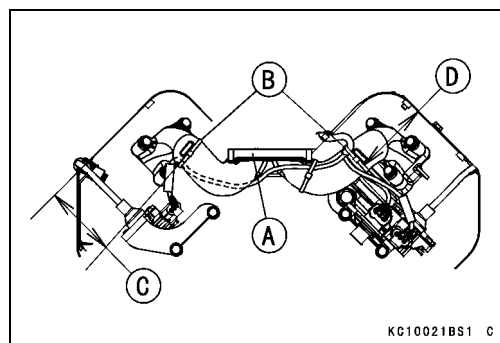

Intake Manifold Inspection

- Inspect the intake manifold for cracks or porous casting.
- Cracks not visible to the eye may be detected by using a metal crack detection system (Visual color check: commonly found at automotive parts store.).
- ★ If a crack is present in the intake manifold, replace it.
- Inspect the gasket surfaces for burns and nicks.

Digital Fuel Injection (DFI) System

DFI System

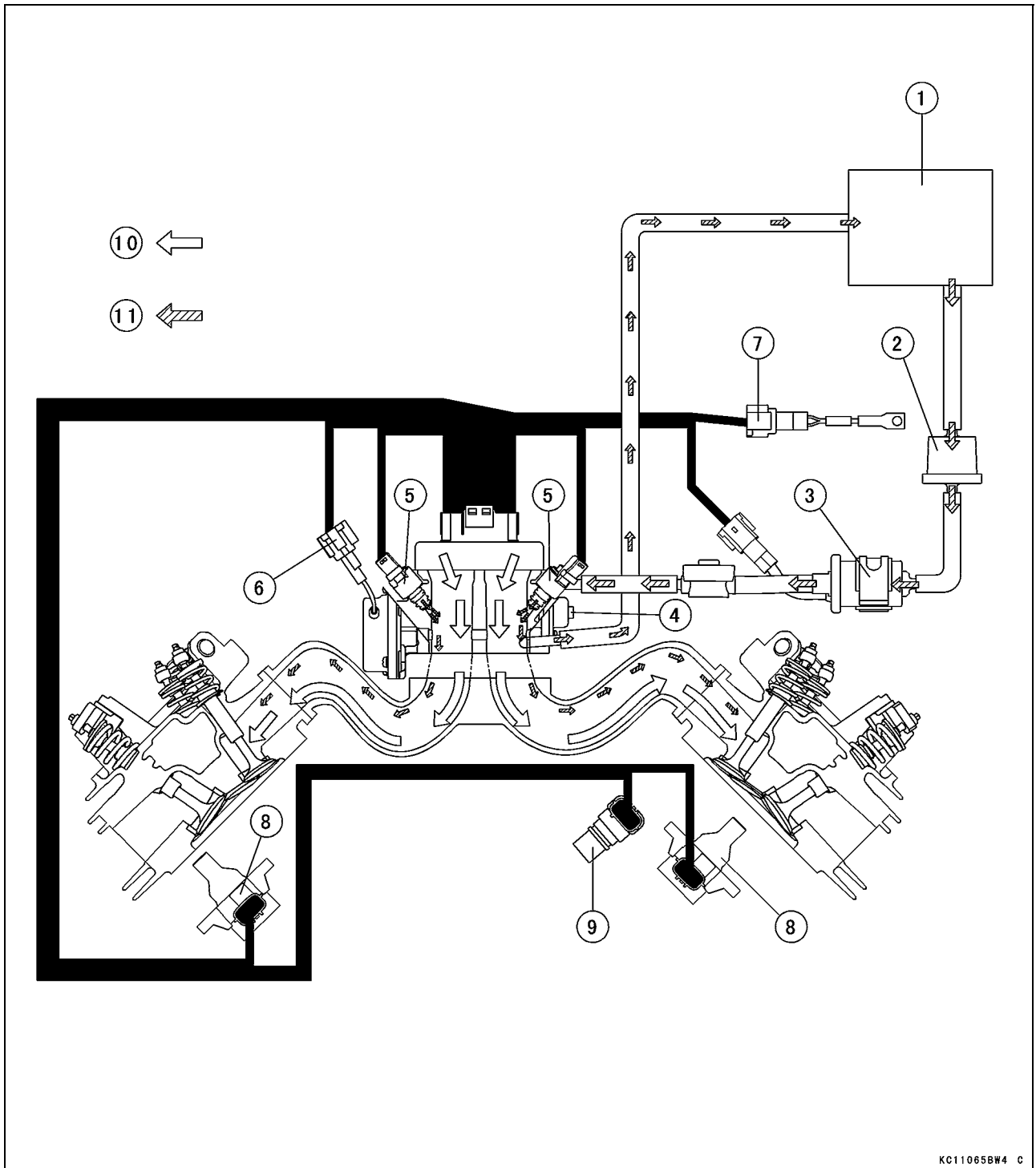

KC11065BW4 C

- 1. Fuel Tank
- 2. Fuel Filter
- 3. Fuel Pump
- 4. Fuel Regulator
- 5. Fuel Injectors
- 6. Governor Motor

- 7. Engine Temperature Sensor
- 8. Ignition Coils
- 9. Crankshaft Position Sensor
- 10. Air Flow
- 11. Fuel Flow

3-10 FUEL SYSTEM (DFI)

Digital Fuel Injection (DFI) System

DFI System Wiring Diagram

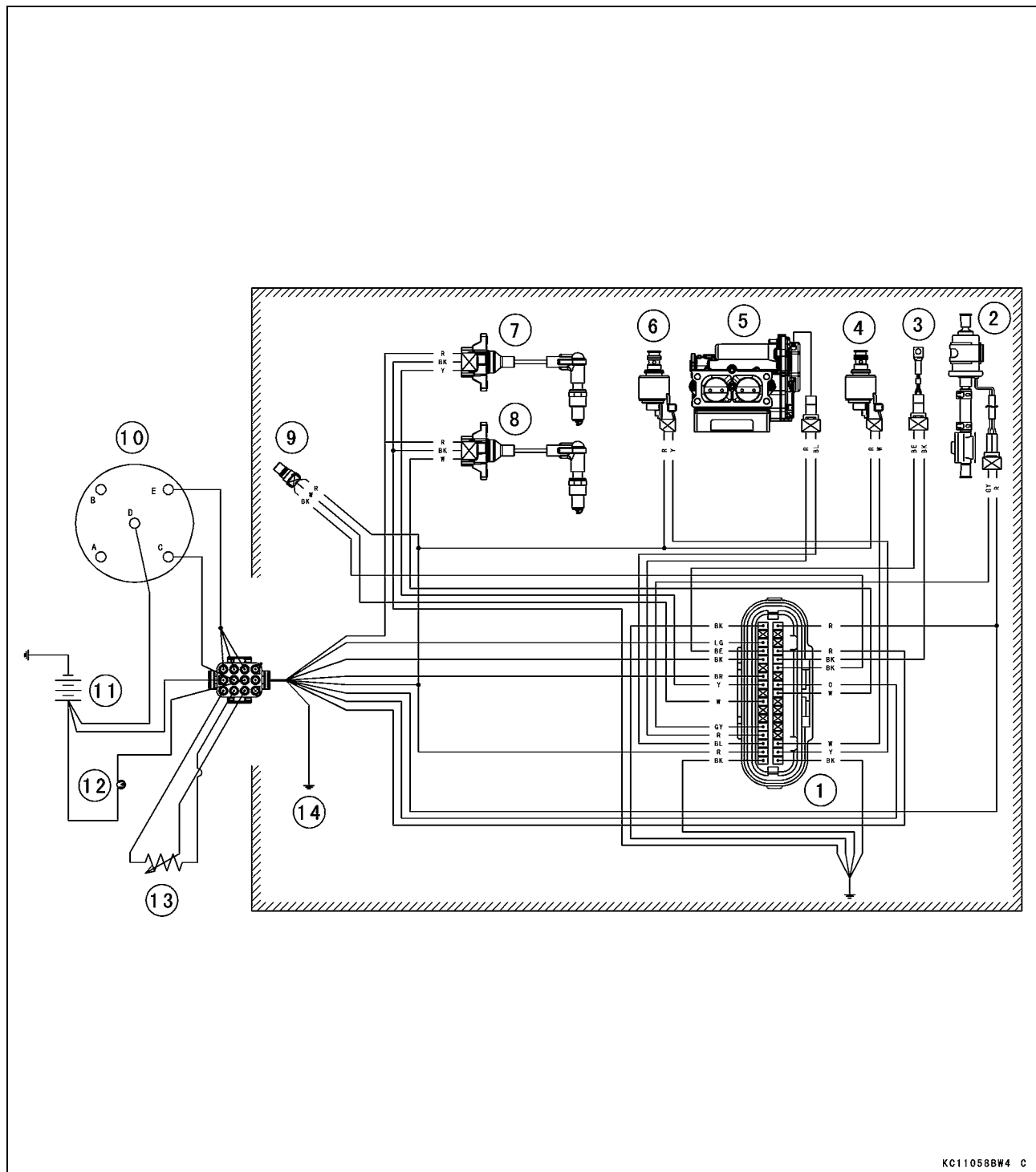

NOTE

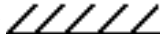
○Portion surrounded by  shows KHI procurement parts.

- | | |
|--|-------------------------------|
| 1. ECU Connector of Throttle Body Assy | 8. Ignition Coil #1 |
| 2. Fuel Pump | 9. Crankshaft Position Sensor |
| 3. Engine Temperature Sensor | 10. Ignition Switch |
| 4. Fuel Injector #2 | 11. Battery 12 V |
| 5. Governor Motor | 12. Self-diagnosis Light |
| 6. Fuel Injector #1 | 13. Throttle Position Sensor |
| 7. Ignition Coil #2 | 14. Engine Ground (Optional) |

Digital Fuel Injection (DFI) System

Terminal Numbers of ECU Connectors

(View from wire side)

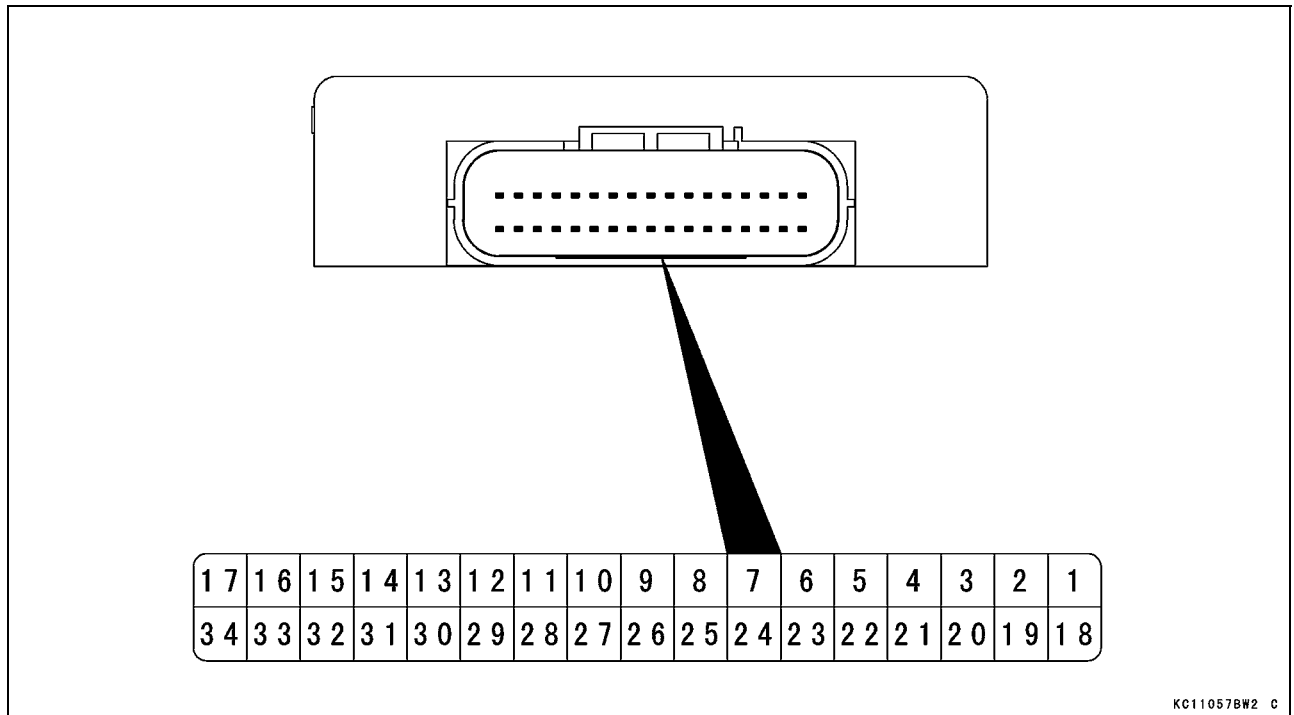

- | | |
|--|---|
| <ol style="list-style-type: none"> 1. Battery 12 V 2. Unused 3. Unused 4. Power Supply to Sensor 5. Ground for Engine Temperature Sensor 6. Ground for Crankshaft Position Sensor 7. Unused 8. Self-diagnosis Light 9. Ignition Coil #2 10. Unused 11. Unused 12. Unused 13. Unused 14. Unused 15. Injector #2 16. Injector #1 17. Power Ground to Governor | <ol style="list-style-type: none"> 18. Ground for ECU 19. Unused 20. Throttle (Accelerator) Position Sensor 21. Engine Temperature Sensor 22. Ground for Throttle (Accelerator) Position Sensor 23. Unused 24. External Communication Line 25. Ignition Coil #1 26. Unused 27. Crankshaft Position Sensor 28. Unused 29. Unused 30. Fuel Pump 31. Governor Motor Control 32. Governor Motor 33. Power Supply to Fuel/Ignition System 34. Power Ground to Fuel Pump |
|--|---|

Safety Instruction for DFI System Servicing

There are a number of important precautions that must be observed when servicing the electronic fuel injection system. Failure to observe these precautions can result in serious damage. Learn and observe all the rule listed below.

Electrical System

1. Do not disconnect the battery leads or any other electrical connections when the key switch is on, or while the engine is running. This is to prevent damaging the ECU.

NOTE

○ Whenever electrical connections are to be disconnected, first turn off the key switch, disconnect the lead which connects the fuel injection system harness to the battery positive (+) post and then disconnect the required connection. There are two other leads which are connected to the battery positive post, but these leads can be left connected.

3-12 FUEL SYSTEM (DFI)

Digital Fuel Injection (DFI) System

2. Conversely, make sure that all electrical connections are firmly reconnected before starting the engine.
3. The fuel injection system is designed to be used with a 12 V battery as its power source.
4. Always disconnect the battery positive and negative leads from the terminals, and remove the battery from the equipment for charging. This is to prevent the control unit from being damaged by excessive peak voltage.
5. Avoid spraying water with any great pressure on the electric components, connectors, leads, and wiring harness of the electronic fuel injection system.
6. Keep the electronic fuel injection system wiring harness as far apart as possible from the high tension leads of the ignition system. This is to prevent the control unit from malfunctioning due to external electrical noise.
7. If a transceiver is installed on the equipment, make sure that the operation of the fuel injection system is not influenced by electric wave radiated from the antenna. Check operation of the system as the engine idles.

NOTE

○Locate the antenna as far as possible apart from the control unit. Interference from radio waves can be reduced by grounding the control unit box to the equipment.

Fuel System

1. Do not operate the fuel pump dry. This is to prevent the pump from running without lubricant at the friction surfaces.
2. Blow the fuel system components with compressed air before removing the parts.

NOTE

○Any hose clamps on the high pressure fuel line must be replaced with new ones once they are loosened.

○Install the hose clamps in the position, and securely tighten the clamps. Check the fuel system for leaks.

3. To prevent corrosion and deposits in the fuel system, do not add any antifreeze chemicals.

Air System

1. In order to maintain the correct fuel/air mixture ratio, there should be no air leaks in the system.

Wiring Inspection

- Visually inspect the wiring for signs of burning, fraying, etc.
- Deteriorated wires and bad unstable operation of the DFI system.
- ★ If any wiring is poor, replace the damaged wiring.
- Pull each connector [A] apart and inspect it for corrosion, dirt, and damage.
- ★ If the connector is corroded or dirty, clean it carefully. If it is damaged, replace it.
- Check the wiring for continuity.

Special Tool - Hand Tester: 57001-1394

- Use the DFI System Wiring Diagram to find the ends of the lead which is suspected of being a problem.
- Measure the resistance between the ends of the leads.
- ★ If the resistance is not 0 Ω , the wire is defective. Replace the lead or the wiring harness if necessary.

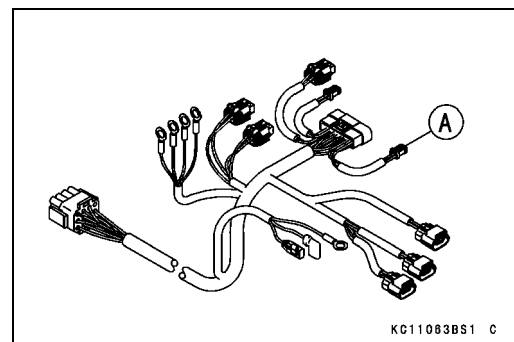

Digital Fuel Injection (DFI) System

ECU Connector Inspection

- Visually inspect the connection of the ECU connector.
- ★ If the connector is clogged with mud or dust, blow it off with compressed air.
- Disconnect the ECU connector and then visually inspect the connectors.
- ★ Replace the main harness if the terminals [A] of the harness connector are cracked, bent or otherwise damaged.
- ★ Replace the throttle body assy if the terminals of the ECU connector are cracked, bent or otherwise damaged.

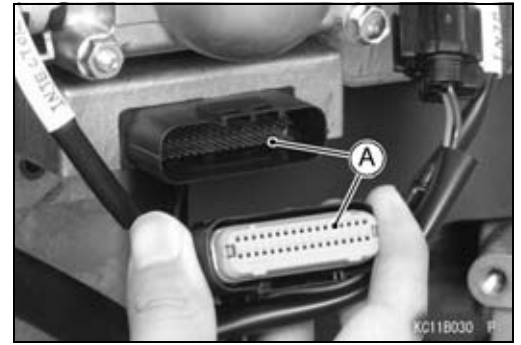

Self-Diagnosis

Self-diagnosis Outline

When an abnormality in the ECU system occurs, the Self-diagnosis light goes on to alert the user.

Self-diagnosis Procedures

- Turn on the ignition switch. The Self-diagnosis light should go on when the switch is turned on.
- Turn off ignition switch.
- ★ If the bulb does not go on as described above, check the bulb and wiring of the diagnosis light in the chassis side harness.
- Turn on the ignition switch again, the Self-diagnosis light should go on.
- After about four seconds, count the number of blinks of the Self-diagnosis light to read the fault code.

NOTE

- Use a fully charged battery when conducting self-diagnosis. Otherwise, the Self-diagnosis light will blink very slowly or not at all.

Model Identification

- The fault code system of FXT00V-AS01 differs from the other models. Check the model code shown on the label [A].

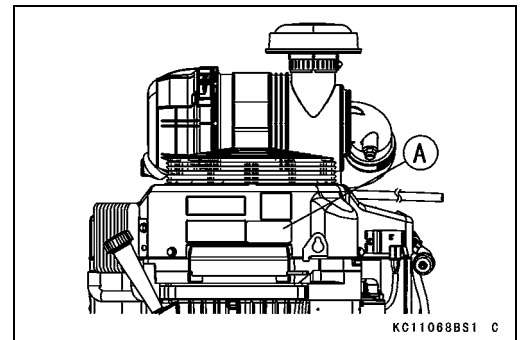

3-14 FUEL SYSTEM (DFI)

Digital Fuel Injection (DFI) System

How to Read Fault Codes

- Fault codes are shown by a series of long and short blinks of the Self-diagnosis light as shown below.
- Read 10th digit and unit digit as the Self-diagnosis light blinks.
- When there are a number of problems, all the fault codes can be stored and the display will begin starting from the lowest number fault code in the numerical order. Then after completing all codes, the display is repeated until the ignition switch is turned OFF.
- If there is no problem, no code is shown.
- For example, if the problems 12 and 22 occur, the fault codes 12 and 22 are shown as follows.

(12 → 22) → (12 → 22) → (repeated)

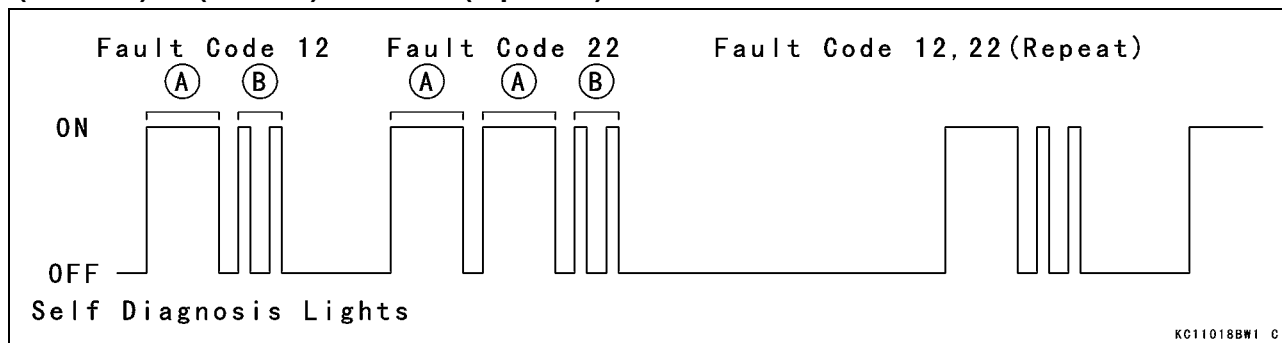

[A]: 10th digit
 [B]: Unit digit









KC11018BW1 C

Models except for FXT00V-AS01

Fault Code	Self-Diagnoss Light	Problems (1)
11	ON OFF	Throttle (Accelerator) position sensor malfunction, wiring open or short
12	ON OFF	Map sensor malfunction, wiring open or short
17	ON OFF	Engine temperature sensor malfunction, wiring open or short
21	ON OFF	Crankshaft position sensor malfunction, wiring open or short
41	ON OFF	Injector #1 malfunction, wiring open or short
42	ON OFF	Injector #2 malfunction, wiring open or short
45	ON OFF	Fuel pump malfunction, wiring open or short
51	ON OFF	Ignition coil #1 malfunction, wiring open or short
52	ON OFF	Ignition coil #2 malfunction, wiring open or short
58	ON OFF	Throttle motor malfunction, wiring open or short
97	ON OFF	Battery voltage abnormal (voltage fall), charging system abnormal

Digital Fuel Injection (DFI) System

FXT00V-AS01

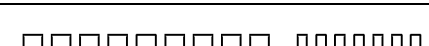
Fault Code	Self-Diagnoss Light	Problems (1)
11	 ON OFF	Governor motor malfunction, wiring open or short
12		Map sensor malfunction, wiring open or short
17		Engine temperature sensor malfunction, wiring open or short
18		Throttle (Accelerator) position sensor malfunction, wiring open or short
21		Crankshaft position sensor malfunction, wiring open or short
41		Injector #1 malfunction, wiring open or short
42		Injector#2 malfunction, wiring open or short
45		Fuel pump malfunction, wiring open or short
97		Battery voltage abnormal (voltage fall), charging system abnormal

Footnotes:

1. The ECU may be involved in these problems. If all the parts, circuits and wiring are good, replace the throttle body assy.

Map Sensor (Fault Code 12)

The map sensor is built in the throttle body assy.

- When this code appears, there is something wrong with the map sensor in the throttle body assy. In this case, any maintenance or adjustment cannot be done.
- Replace the throttle body assy (see Throttle Body Assy Removal).

Engine Temperature Sensor (Fault Code 17)

Engine Temperature Sensor Removal

- Disconnect the engine temperature sensor connector [A].
- Free the engine temperature sensor lead from the engine temperature sensor lead clamp [B].
- Remove:
 - Bolt [C]
 - Engine Temperature Sensor [D]

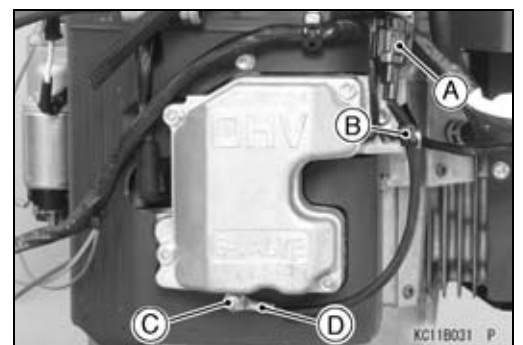

3-16 FUEL SYSTEM (DFI)

Digital Fuel Injection (DFI) System

Engine Temperature Sensor Installation

- Install the engine temperature sensor [A] as shown in the figure, and tighten the bolt [B].

10° [C]

Torque - Engine Temperature Sensor Mounting Bolt [B]: 5.9 N-m (0.60 kgf-m, 52 in-lb)

- Connect the engine temperature sensor connector [D].
- Attach the engine temperature sensor lead to the engine temperature sensor lead clamp [E].

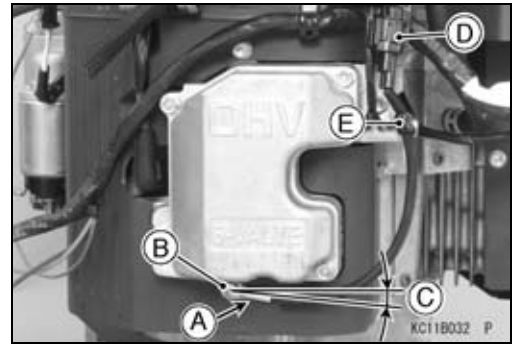

Engine Temperature Sensor Resistance Inspection

- Disconnect the engine temperature sensor connector (see Engine Temperature Sensor Removal).
- Measure the engine temperature sensor resistance with the hand tester [A].

Special Tool - Hand Tester: 57001-1394

Engine Temperature Sensor Resistance Standard: 10 kΩ at 25°C (77°F)

- ★ If the reading is out of the standard, replace the engine temperature sensor.
- ★ If the reading is good, inspect the wiring (see Wiring Inspection).
- ★ If the wiring is good, replace the throttle body assy (see Throttle Body Assy Removal).

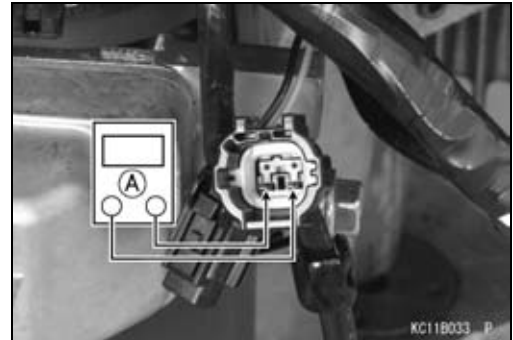

Crankshaft Position Sensor (Fault Code 21)

Crankshaft Position Sensor Removal

- Remove the fan housing (see Flywheel and Stator Coil Removal in the Electrical System chapter).
- Disconnect the crankshaft position sensor connector [A].
- Remove:
 - Bolt [B]
 - Crankshaft Position Sensor [C]

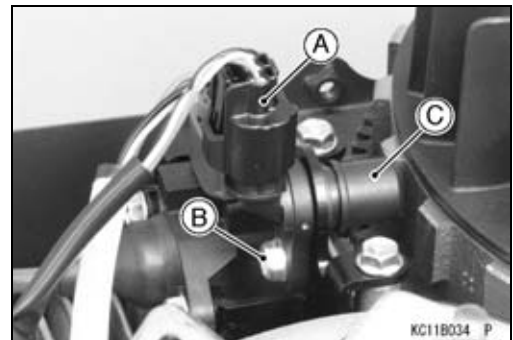

Crankshaft Position Sensor Installation

- Install the crankshaft position sensor [A].
- Tighten:
 - Torque - Crankshaft Position Sensor Mounting Bolt [B]: 5.9 N-m (0.60 kgf-m, 52 in-lb)**
- Connect the crankshaft position sensor connector [C].
- Check the crankshaft position sensor air gap.

Crankshaft Position Sensor Air Gap Standard: 0.5 ~ 0.7 mm (0.020 ~ 0.028 in.)

- If the air gap is out of the standard, adjust the air gap (see Ignition Coil Installation in the Electrical System chapter).

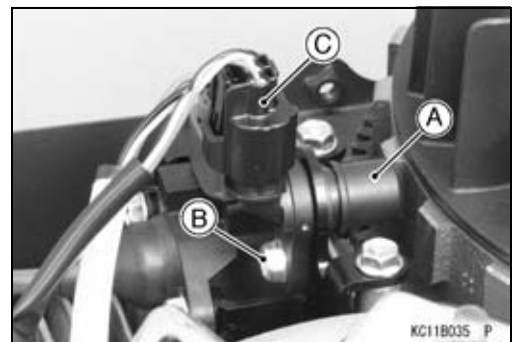

Digital Fuel Injection (DFI) System

Crankshaft Position Sensor Inspection

- Remove the crankshaft position sensor (see Crankshaft Position Sensor Removal).
- Connect the crankshaft position sensor connector [A] with the battery [B], 10 kΩ resistor [C] and hand tester [D] as shown.
- Set the tester to the DC 25 V range.

Special Tool - Hand Tester: 57001-1394

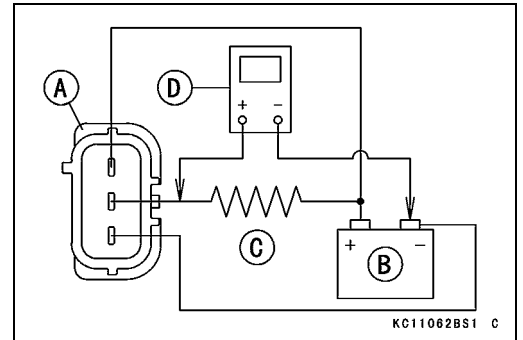

- Trace [A] each side of the crankshaft position sensor surface with the screw driver.
- Then the tester indicator should flick [B].
- ★ If the tester indicator does not flick, replace the crankshaft position sensor.
- ★ If the tester indicator flicks, inspect the wiring (see Wiring Inspection).
- ★ If the wiring is good, replace the throttle body assy (see Throttle Body Assy Removal).

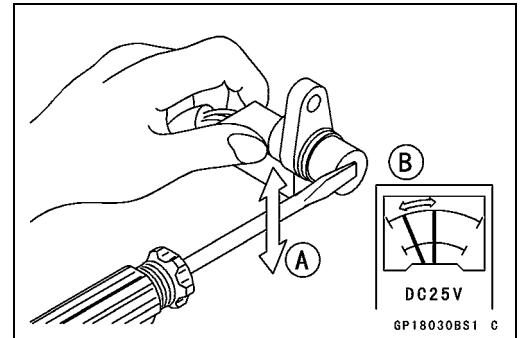

Fuel Injectors #1, #2 (Fault Code 41, 42)

Fuel Injector #1: (Fault Code 41)

Fuel Injector #2: (Fault Code 42)

CAUTION

Never drop the fuel injector, especially on a hard surface. Such a shock to the fuel injector can damage it.

Fuel Injector Removal

- Remove:
 - Throttle Body Assy (see Throttle Body Assy Removal)
 - Screws [A]
- Pull out the fuel injectors [B] with the holders.

NOTE

- Take care not to damage the fuel injector inserts when they are pulled from the throttle body assy.

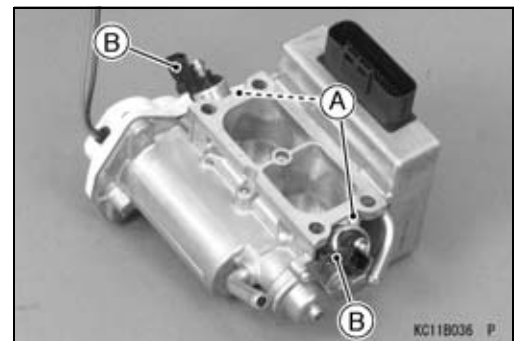

Fuel Injector Installation

- Set the holders [A] to the fuel injectors [B] as shown in the figure.



3-18 FUEL SYSTEM (DFI)

Digital Fuel Injection (DFI) System

- Install the fuel injectors [A] with the holders to the throttle body assy [B].
- Tighten the screws [C].

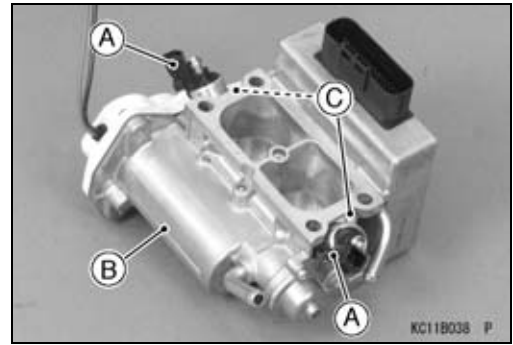

Audible Inspection

NOTE

○ Be sure the battery is fully charged.

- Start the engine and let it idle.
- Apply the tip of a screwdriver [A] to the fuel injector [B]. Put the grip end onto your ear, and listen whether the injector is clicking or not.
- A sound scope [C] can also be used.
- The click interval becomes shorter as the engine speed rises.
- Do the same for the other fuel injector.
- ★ If all the fuel injectors click at a regular intervals, the fuel injectors are good.
- Turn the ignition switch OFF.
- ★ If any fuel injector does not click, check the fuel injector resistance (see Fuel Injector Resistance Inspection).

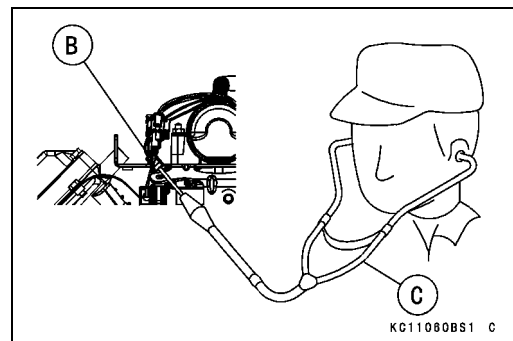
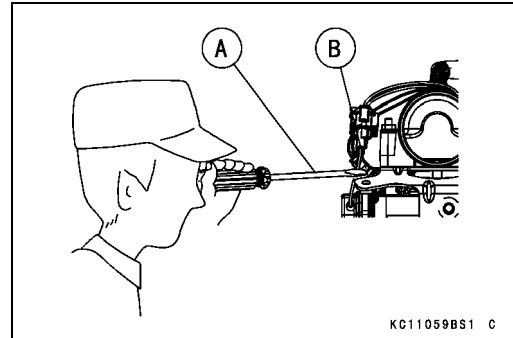

Fuel Injector Resistance Inspection

- Disconnect the fuel injector connectors (see Throttle Body Assy Removal).
- Measure the fuel injector resistance with hand tester [A].

Special Tools - Hand Tester: 57001-1394

Needle Adapter Set: 57001-1457

Fuel Injector Resistance

Standard: 23.5 ±1 Ω at 25°C (77°F)

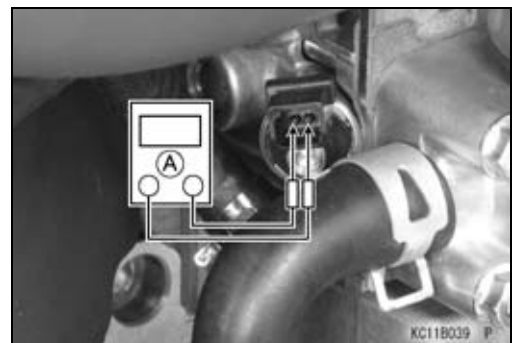

- ★ If the reading is out of the standard, replace the fuel injector.

NOTE

○ When replacing the fuel injector, see the injector flow number [A] shown on the throttle body assy [B] and use the same type as a replacement.

- ★ If the reading is good, inspect the wiring (see Wiring Inspection).
- ★ If the wiring is good, replace the throttle body assy (see Throttle Body Assy Removal).

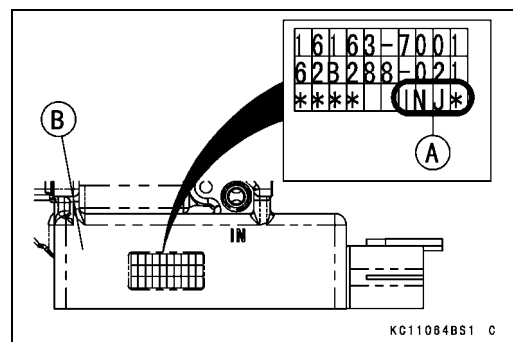

Digital Fuel Injection (DFI) System

Fuel Pump (Fault Code 45)

Fuel Pump Removal

- Disconnect the fuel pump connector [A].
- Remove:
 - Bolt [B]
 - Clamps [C]
 - Fuel Hoses [D] (from the Fuel Pump [E])

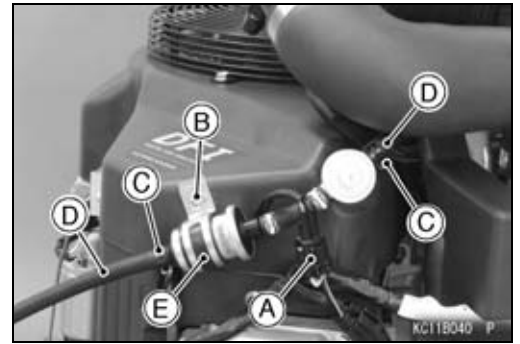

Fuel Pump Installation

- Connect the fuel hoses [A] fully and install the clamps [B].
- Install the fuel pump [C] as shown in the figure, and tighten the bolt [D].

Torque - Fuel Pump Mounting Bolt: 5.9 N·m (0.60 kgf·m, 52 in·lb)

- Connect the fuel pump connector [E].

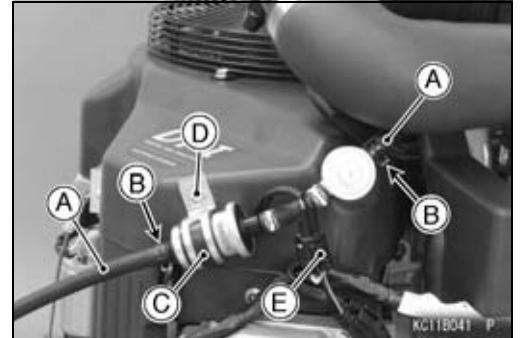

Fuel Pump Resistance Inspection

- Disconnect the fuel pump connector (see Engine Temperature Sensor Removal).
- Measure the fuel pump resistance with the hand tester [A].

Special Tool - Hand Tester: 57001-1394

Fuel Pump Resistance

Standard: 3.5 Ω at 20°C (68°F)

- ★ If the reading is out of the standard, replace the fuel pump.
- ★ If the reading is good, inspect the wiring (see Wiring Inspection).
- ★ If the wiring is good, replace the throttle body assy (see Throttle Body Assy Removal).

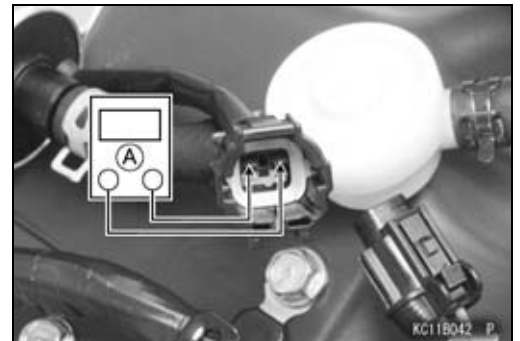

Battery Voltage (Fault Code 97)

- When this code appears, the battery is low voltage.
- Inspect the battery and charge.
- Inspect the charging system parts.
- ★ If the battery and charging system parts is good, replace the throttle body assy (see Throttle Body Assy Removal).

Throttle (Accelerator) Position Sensor (Fault Code 11) (Models except for FXT00V-AS01)

- When this code appears, there may be something wrong with the throttle (accelerator) position sensor of the equipment to which this engine is attached or the harness between the ECU and the throttle (accelerator) position sensor may break.
- Inspect the throttle (accelerator) position sensor of the equipment to which this engine is attached and the wiring.
- ★ If there is any failure, replace the damaged parts.
- ★ If there is not any failure, replace the throttle body assy (see Throttle Body Assy Removal).

3-20 FUEL SYSTEM (DFI)

Digital Fuel Injection (DFI) System

Ignition Coil (Fault Code 51, 52) (Models except for FXT00V-AS01)

Ignition Coil #1: (Fault Code 51)

Ignition Coil #2: (Fault Code 52)

Ignition Coil Removal/Installation

- Refer to the Ignition Coil Removal and Installation in the Electrical System chapter.

Ignition Coil Inspection

- Refer to the Ignition Coil Inspection in the Electrical System chapter.

Ignition Coil Wiring Continuity Inspection

- Remove:
 - Intake Pipe Outer Cover (see Intake Pipe Removal)
 - Fan Housing (see Flywheel and Stator Coil Removal in the Electrical System chapter)
- Check the wiring for continuity between main harness connectors with the hand tester and suitable leads.

Special Tool - Hand Tester: 57001-1394

Ignition Coil #1

- Disconnect the ECU connector and ignition coil #1 connector.

Wiring Continuity Inspection

ECU Connector [A] ↔

Ignition Coil #1 Connector [B]

Y lead (ECU terminal 25) [C]

BK leads (ECU terminal 17, 18, 34) [D]

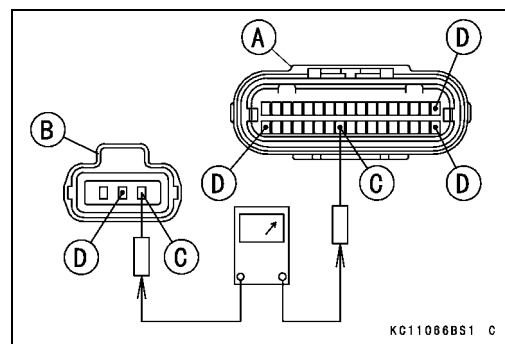

Wiring Continuity Inspection

Engine Main Harness Connector [A] ↔

Ignition Coil #1 Connector [B]

R lead [C]

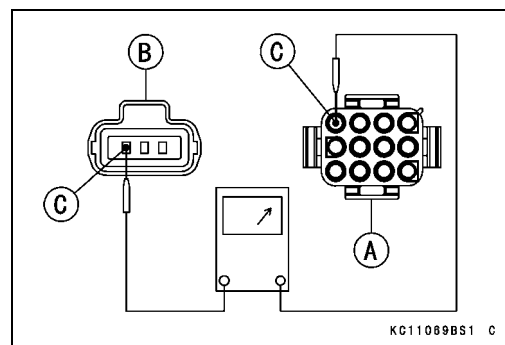

Ignition Coil #2

- Disconnect the ECU connector and ignition coil #2 connector.

Wiring Continuity Inspection

ECU Connector [A] ↔

Ignition Coil #2 Connector [B]

W lead (ECU terminal 9) [C]

BK leads (ECU terminal 17, 18, 34) [D]

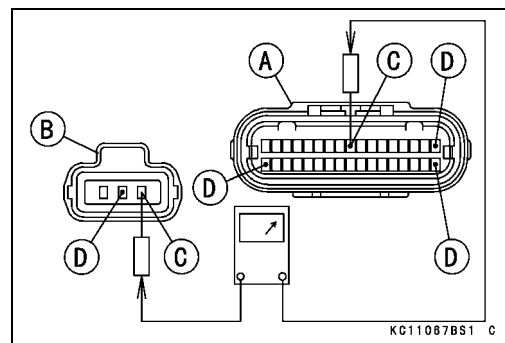

Digital Fuel Injection (DFI) System

Wiring Continuity Inspection

- Engine Main Harness Connector [A] ↔
- Ignition Coil #2 Connector [B]
- R lead [C]

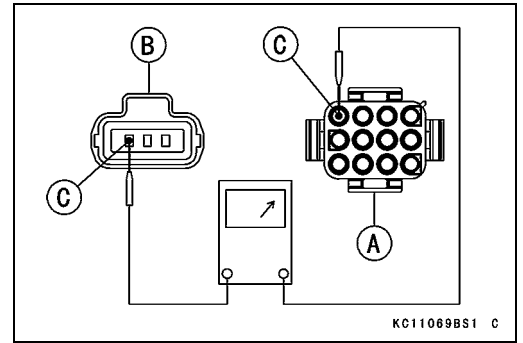

★If the wiring is good, replace the throttle body assy (see Throttle Body Assy Removal).

Throttle Motor (Fault Code 58) (Models except for FXT00V-AS01)

Throttle Motor Removal/Adjustment

CAUTION

Do not remove or adjust the throttle motor [A] since they have been adjusted and set with precision at the factory.
 Never drop the throttle body assy, especially on a hard surface. Such a shock to the throttle motor can damage it.

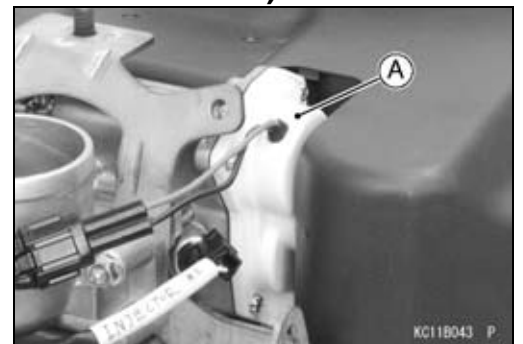

Throttle Motor Wiring Continuity Inspection

- Remove the intake pipe outer cover (see Intake Pipe Removal).
- Check the wiring for continuity between main harness connector with the hand tester and suitable leads.

Special Tool - Hand Tester: 57001-1394

- Disconnect the ECU connector and throttle motor connector.

Wiring Inspection

- ECU Connector [A] ↔
- Throttle Motor Connector [B]
- R lead (ECU terminal 31) [C]
- BL lead (ECU terminal 32) [D]

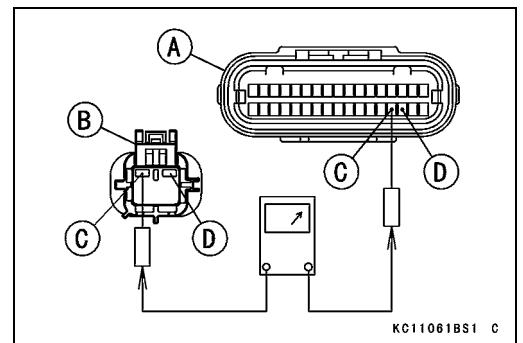

★If the wiring is good, replace the throttle body assy (see Throttle Body Assy Removal).

3-22 FUEL SYSTEM (DFI)

Digital Fuel Injection (DFI) System

Governor Motor (Fault Code 11) (FXT00V-AS01)

Governor Motor Removal/Adjustment

CAUTION

Do not remove or adjust the governor motor [A] since they have been adjusted and set with precision at the factory.

Never drop the throttle body assy, especially on a hard surface. Such a shock to the governor motor can damage it.

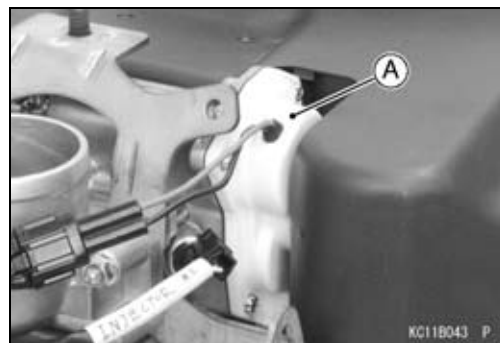

Governor Motor Wiring Continuity Inspection

- Remove the intake pipe outer cover (see Intake Pipe Removal).
- Check the wiring for continuity between main harness connector with the hand tester and suitable leads.

Special Tool - Hand Tester: 57001-1394

- Disconnect the ECU connector and governor motor connector.

Wiring Continuity Inspection

ECU Connector [A] ←→

Governor Motor Connector [B]

R lead (ECU terminal 31) [C]

BL lead (ECU terminal 32) [D]

- ★ If the wiring is good, replace the throttle body assy (see Throttle Body Assy Removal).

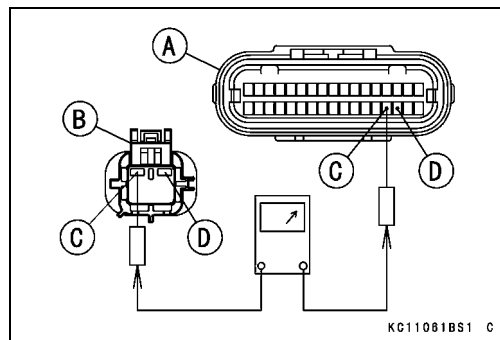

Throttle (Accelerator) Position Sensor (Fault Code 18) (FXT00V-AS01)

- When this code appears, there may be something wrong with the throttle (accelerator) position sensor of the equipment to which this engine is attached or the harness between the ECU and the throttle (accelerator) position sensor may break.
- Inspect the throttle (accelerator) position sensor of the equipment to which this engine is attached and the wiring.
- ★ If there is any failure, replace the damaged parts.
- ★ If there is not any failure, replace the throttle body assy (see Throttle Body Assy Removal).

Fuel Filter

Fuel Filter Removal/Installation

- Remove:
 - Clamp [A]
 - Fuel Filter [B]
- When install the fuel filter, arrow mark [C] faces fuel pump side.

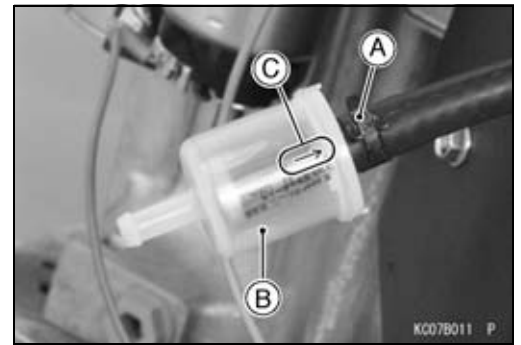

Fuel Filter Inspection

- Visually inspect the fuel filter [A].
- ★ If the filter is clear with no signs of dirt or other contamination, replacement of the fuel filter is not necessary.
- ★ If the filter is dark or looks dirty, replace it with a new one. Also check the rest of the fuel system for contamination.

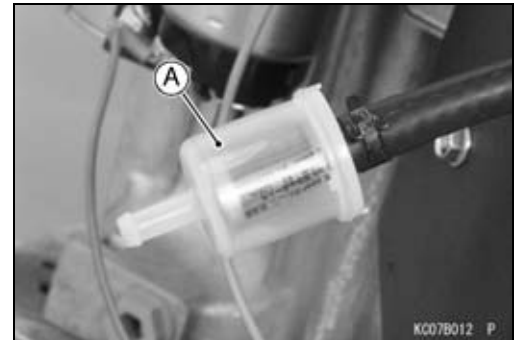

3-24 FUEL SYSTEM (DFI)

Air Cleaner

Element Removal

- While pulling up the knob [A], turn the cap [B] to counter-clockwise.



- Align the arrow mark [A] and unlock mark [B] to remove the cap.

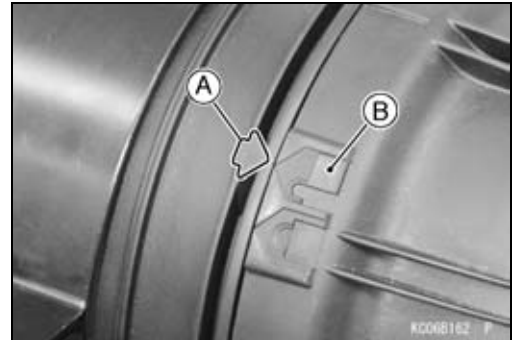

- Remove the primary element [A].



- Remove the secondary element [A].



Element Installation

- Slide the secondary element and primary element into place in the air cleaner body.
- Align the arrow mark [A] on the body and unlock mark [B] on the cap.



Air Cleaner

- Turn the cap to the clockwise until the lock mark [A].



Element Cleaning and Inspection

Air cleaner elements are not recommended to be cleaned, and each air cleaner element should be replaced with new ones.

- Refer to the Element Cleaning and Inspection in the Periodic Maintenance chapter.

Air Cleaner Body and Bracket Removal

- Remove the air cleaner elements, if necessary (see Element Removal).
- Loosen the clamp [A].
- Remove:
 - Bolt [B]
 - Upper Bracket [C]
- Take out the air cleaner body [D] together with the intake hose [E].

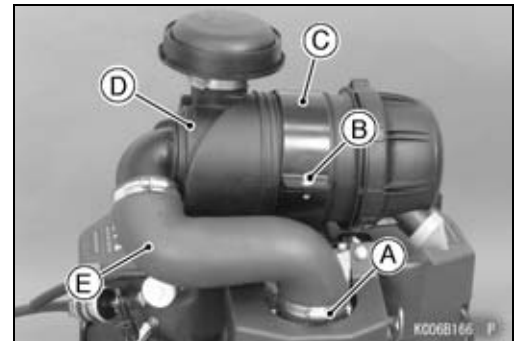

- Remove:
 - Nut [A]
 - Bolts [B]
 - Lower Bracket [C]

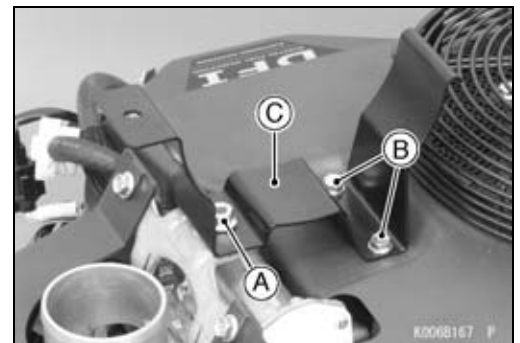

Air Cleaner Body and Bracket Installation

- Install:
 - Lower Bracket [A]
 - Bolts [B]
 - Nut [C]
- Tighten:
 - Torque - Air Cleaner Body Bracket Mounting Nut: 19.6 N·m (2.0 kgf·m, 14 ft·lb)
 - Air Cleaner Body Bracket Mounting Bolts: 5.9 N·m (0.60 kgf·m, 52 in·lb)

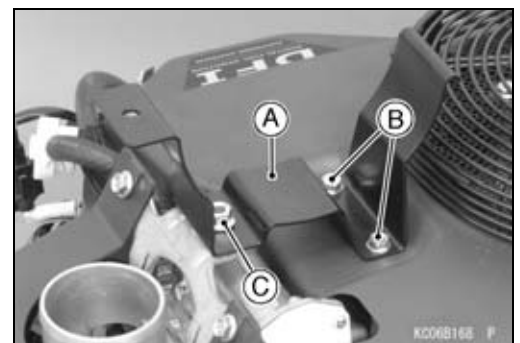

3-26 FUEL SYSTEM (DFI)

Air Cleaner

- Set the air cleaner body [A] onto the lower bracket so that the air intake duct [B] is facing upward.
- Install the intake hose [C], and tighten the clamp [D].
- Install the upper bracket [E].
- Tighten:

**Torque - Air Cleaner Mounting Bracket Bolt [F]: 19.6 N·m
(2.0 kgf·m, 14 ft·lb)**

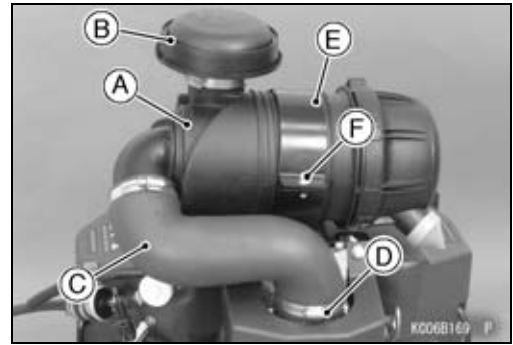

Air Cleaner Housing (Cap and Body) Inspection

- Refer to the Air Cleaner Housing (Cap and Body) Inspection in the Periodic Maintenance chapter.

Cooling System

Table of Contents

Exploded View 4-2

Cooling Fan 4-4

 Cooling Fan Removal 4-4

 Cooling Fan Installation 4-4

 Cooling Fan Inspection 4-4

Engine Shroud..... 4-5

 Engine Shroud Removal..... 4-5

 Engine Shroud Installation..... 4-6

4-2 COOLING SYSTEM

Exploded View

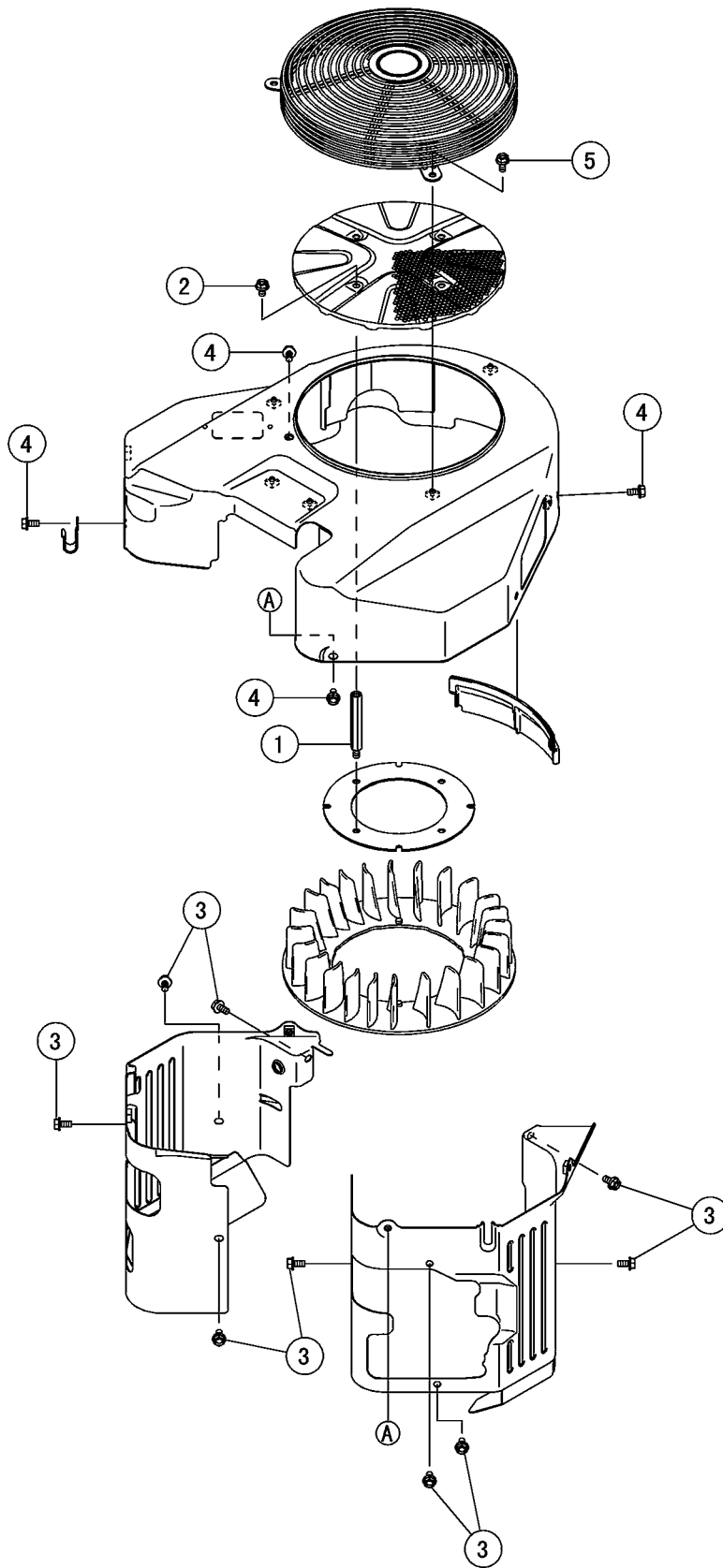

Exploded View

No.	Fastener	Torque			Remarks
		N-m	kgf-m	ft-lb	
1	Cooling Fan Plate Mounting Stud Bolts	5.9	0.60	52 in·lb	
2	Cooling Fan Screen Bolts	5.9	0.60	52 in·lb	
3	Engine Shroud Bolts	5.9	0.60	52 in·lb	
4	Fan Housing Bolts	5.9	0.60	52 in·lb	
5	Guard Mounting Bolts	5.9	0.60	52 in·lb	

4-4 COOLING SYSTEM

Cooling Fan

Cooling Fan Removal

- Refer to the Flywheel and Stator Coil Removal in the Electrical System chapter.

Cooling Fan Installation

- Refer to the Flywheel and Stator Coil Installation in the Electrical System chapter.

Cooling Fan Inspection

- Remove the fan housing (see Flywheel and Stator Coil Removal in the Electrical System chapter).
- Visually inspect the blades [A] in the cooling fan.
- ★ If they have any crack, warp or damage, replace the cooling fan with a new one.
- ★ If any mud or dust have stuck to the cooling fan, clean it.
- Wash the cooling fan in detergent and water.

CAUTION

Do not clean the cooling fan in oil solvent. It may be damage by oil solvent.

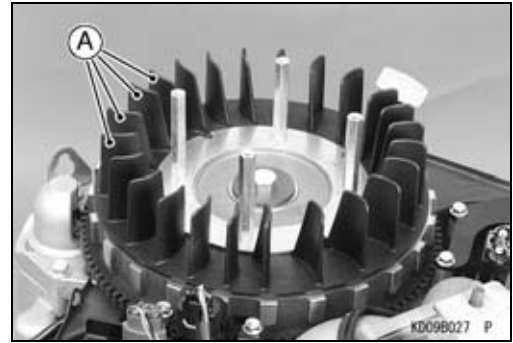

Engine Shroud

Engine Shroud Removal

● Remove:

- Fan Housing (see Flywheel and Stator Coil Removal in the Electrical System chapter)
- Spark Plug Caps (see Ignition Coil Removal in the Electrical System chapter)
- Rocker Covers (see Cylinder Head Assembly Removal in the Engine Top End chapter)
- Engine Temperature Sensor (see Engine Temperature Sensor Removal in the Fuel System (DFI) chapter)
- Switch Lead (see Starter Solenoid and Circuit Test chapter)
- ECU Connector (see Throttle Body Assy Removal in the Fuel System (DFI) chapter)
- Injector Connectors (see Throttle Body Assy Removal in the Fuel System (DFI) chapter)
- Governor (Throttle) Motor Connector (see Throttle Body Assy Removal in the Fuel System (DFI) chapter)
- Bolt [A] and Engine Ground Terminal Leads

● Remove:

- Bolts [A]
- Engine Shrouds [B]

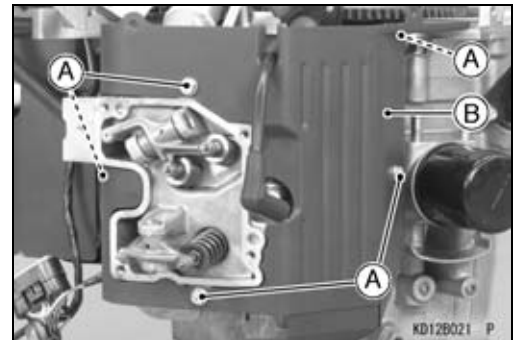
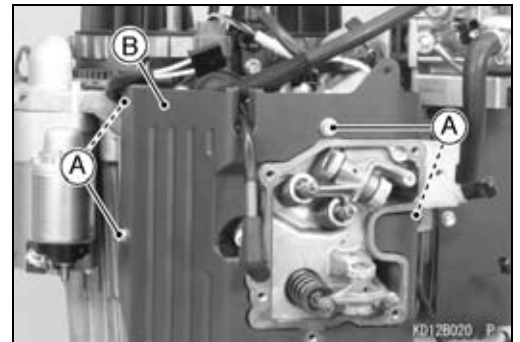
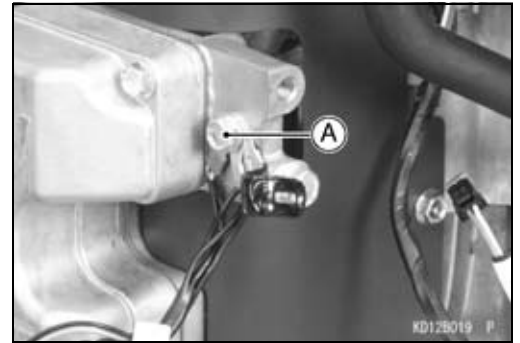

4-6 COOLING SYSTEM

Engine Shroud

Engine Shroud Installation

- Install the engine shrouds [A].
- Tighten:
Torque - Engine Shroud Bolts [B]: 5.9 N·m (0.60 kgf·m, 52 in·lb)

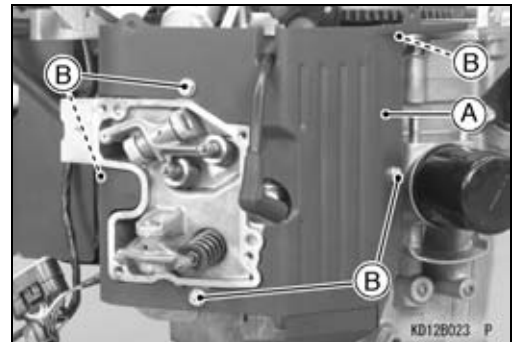
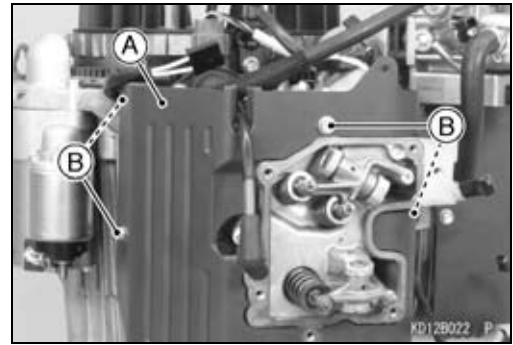

- Install the engine ground leads and tighten the bolt [A].
Torque - Engine Ground Terminal Bolt: 5.9 N·m (0.60 kgf·m, 52 in·lb)

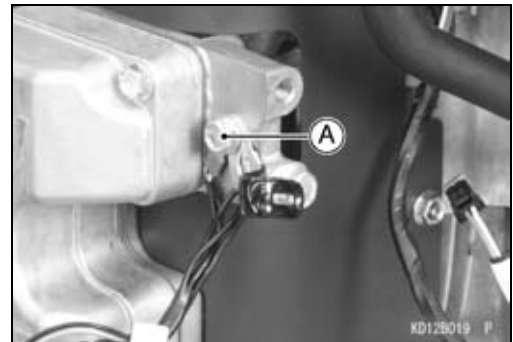

- Install the removed parts (see appropriate chapters).

Engine Top End

Table of Contents

Exploded View	5-2
Specifications	5-4
Special Tools	5-6
Cylinder Head.....	5-7
Compression Measurement.....	5-7
Cylinder Head Assembly Removal	5-8
Cylinder Head Assembly Installation	5-8
Push Rod Removal.....	5-9
Push Rod Installation.....	5-10
Push Rod Inspection.....	5-10
Valve Mechanism Removal/Installation	5-10
Cylinder Head Cleaning.....	5-11
Cylinder Head Inspection.....	5-11
Rocker Arm Inspection.....	5-12
Valves	5-13
Valve Clearance Inspection	5-13
Valve Clearance Adjustment.....	5-13
Valve Seat Inspection	5-13
Valve Seat Repair	5-13
Valve Head Thickness	5-13
Valve Stem Runout	5-13
Valve Stem Diameter	5-13
Valve Guide Inside Diameter	5-14
Valve Spring Inspection	5-14
Cylinder, Piston.....	5-15
Piston Removal.....	5-15
Piston Installation.....	5-16
Piston/Cylinder Seizure.....	5-18
Piston Cleaning.....	5-18
Piston Ring and Ring Groove Wear.....	5-18
Piston Ring End Gap	5-19
Piston Pin, Piston Pin Hole, and Connecting Rod Wear.....	5-19
Piston Diameter	5-20
Cylinder Inside Diameter.....	5-20
Cylinder Boring and Honing.....	5-21

5-2 ENGINE TOP END

Exploded View

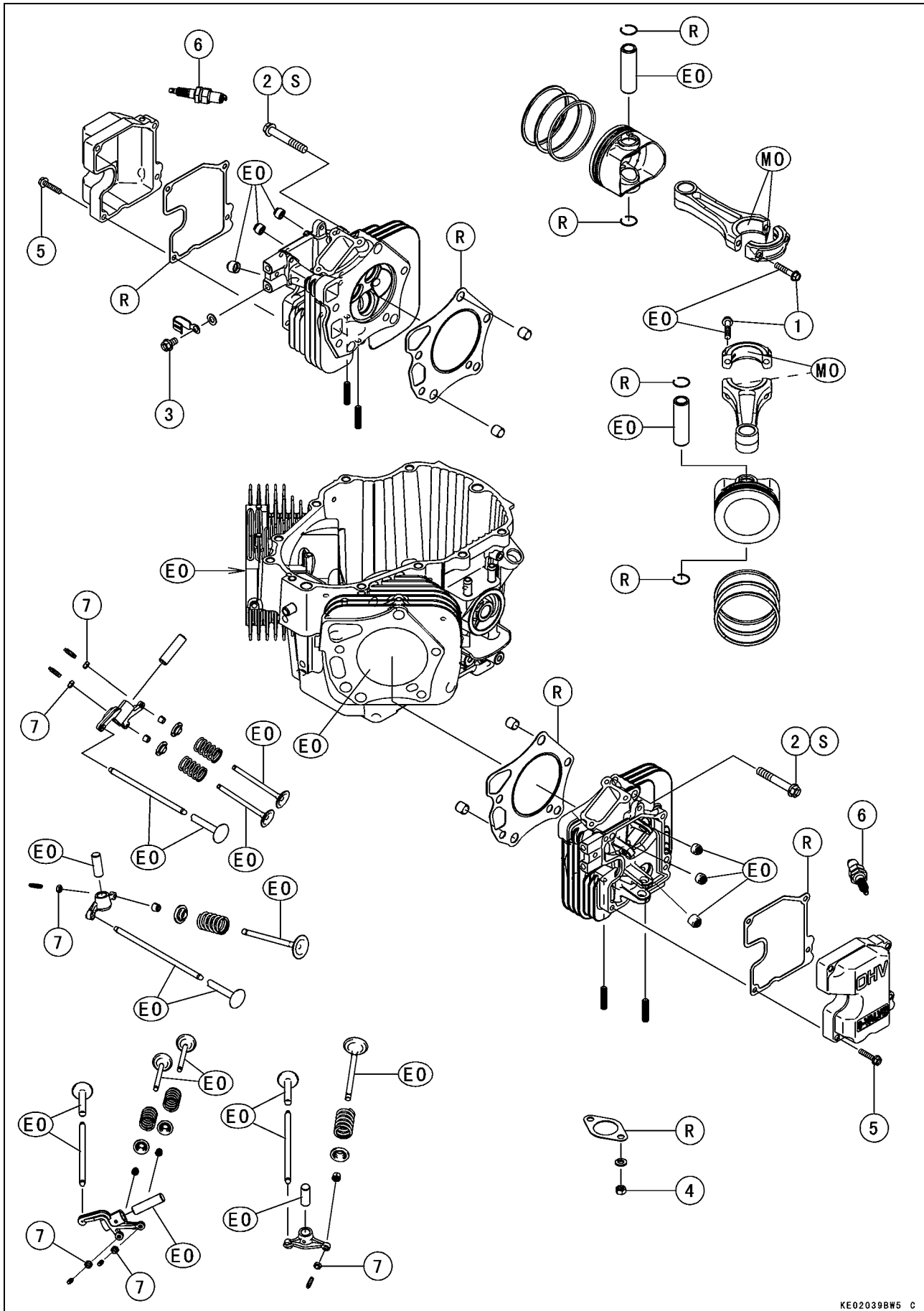

Exploded View

No.	Fastener	Torque			Remarks
		N-m	kgf-m	ft-lb	
1	Connecting Rod Big End Cap Bolts	20.6	2.10	15.2	EO
2	Cylinder Head Bolts	46	4.7	34	S
3	Engine Temperature Sensor Lead Clamp Bolt	19.6	2.0	14	
4	Exhaust Pipe Nuts	22	2.2	16	
5	Rocker Cover Bolts	5.9	0.60	52 in-lb	
6	Spark Plugs	22	2.2	16	
7	Valve Clearance Adjusting Locknuts	9.8	1.0	87 in-lb	

EO: Apply engine oil.

MO: Apply molybdenum disulfide oil.

R: Replacement Parts

S: Tighten the fasteners following the specified sequence.

5-4 ENGINE TOP END

Specifications

Item	Service Limit
Cylinder Head	
Cylinder Compression (MIN)	555 kPa (80 psi) @ Engine Oil Temperature 50 ~ 60°C (122 ~ 144°F), Cranking Speed 500 rpm/5 Seconds
Cylinder Head Warp	0.05 mm (0.002 in.)
Valves	
Valve Head Thickness Intake, Exhaust	0.4 mm (0.016 in.)
Valve Stem Runout Intake, Exhaust	TIR 0.05 mm (0.002 in.)
Valve Stem Diameter Intake Exhaust	5.95 mm (0.234 in.) 6.93 mm (0.273 in.)
Valve Guide Inside Diameter Intake Exhaust	6.08 mm (0.239 in.) 7.08 mm (0.279 in.)
Valve Spring Free Length Intake Exhaust	31.0 mm (1.22 in.) 34.5 mm (1.36 in.)
Rocker Arm Push Rod Runout Intake, Exhaust	0.2 mm (0.008 in.)
Rocker Shaft Outside Diameter Intake, Exhaust	11.95 mm (0.470 in.)
Rocker Arm Inside Diameter Intake, Exhaust	12.05 mm (0.474 in.)
Cylinder, Piston	
Piston Diameter	88.93 mm (3.501 in.)
Piston Ring/Groove Clearance: Top Second	0.14 mm (0.0055 in.) 0.14 mm (0.0055 in.)
Piston Ring Thickness Top, Second	1.9 mm (0.075 in.)
Piston Ring End Gap: Top Second Oil	0.7 mm (0.028 in.) 0.8 mm (0.031 in.) 1.0 mm (0.039 in.)
Piston Pin Outside Diameter	20.96 mm (0.825 in.)
Piston Pin Hole Inside Diameter	21.08 mm (0.830 in.)
Connecting Rod Small End Inside Diameter	21.06 mm (0.829 in.)
Cylinder Inside Diameter: Standard Cylinder 0.50 mm Oversize Cylinder	89.23 mm (3.513 in.) 89.73 mm (3.534 in.)
Cylinder Inside Diameter Out Round	0.05 mm (0.002 in.)

Specifications

Item	Standard
Valve Clearance: Intake, Exhaust	0.10 ~ 0.15 mm (0.004 ~ 0.006 in.)
Valve Seating Surface Angle: Intake, Exhaust	45°
Valve Seating Surface Width: Intake Exhaust	0.7 ~ 1.1 mm (0.028 ~ 0.043 in.) 1.0 ~ 1.5 mm (0.039 ~ 0.059 in.)
Valves Guide Inside Diameter: Intake Exhaust	6.000 ~ 6.015 mm (0.2362 ~ 0.2368 in.) 7.000 ~ 7.015 mm (0.2756 ~ 0.2762 in.)
Cylinder Inside Diameter: Standard Cylinder 0.50 mm Oversize Cylinder	89.13 ~ 89.15 mm (3.509 ~ 3.510 in.) 89.63 ~ 89.65 mm (3.529 ~ 3.530 in.)

5-6 ENGINE TOP END

Special Tools

Piston Ring Pliers:
57001-115

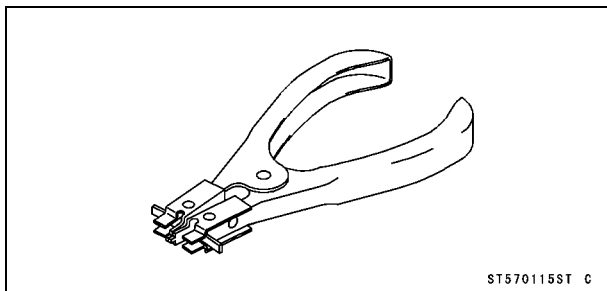

Compression Gauge, 20 kgf/cm²:
57001-221

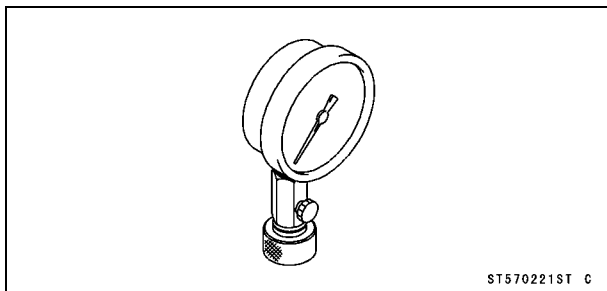

Piston Ring Compressor Grip:
57001-1095

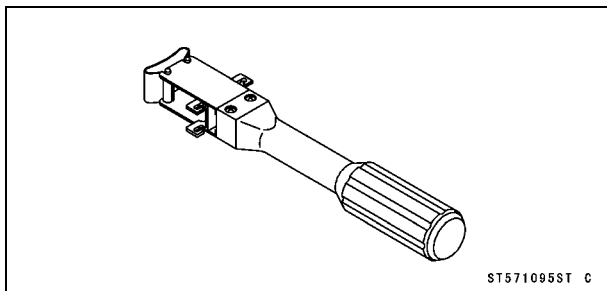

Compression Gauge Adapter, M14 x 1.25:
57001-1159

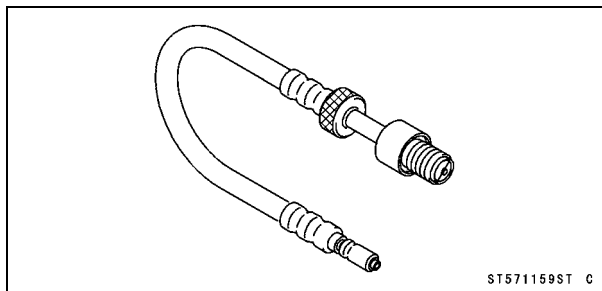

Piston Ring Compressor Belt, $\phi 80 \sim \phi 91$:
57001-1320

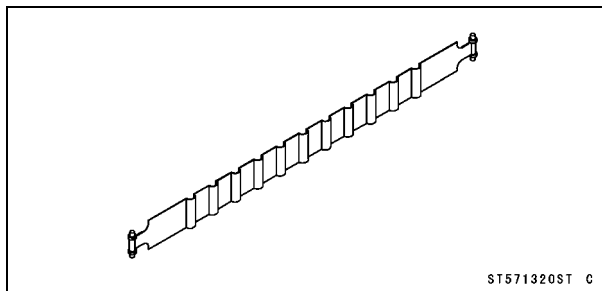

Cylinder Head

Compression Measurement

- Before measuring compression, do the following.
 - Be sure the battery is fully charged.
 - Thoroughly warm up the engine so that engine oil between the piston and cylinder wall will help sealing the compression as it does during normal running.
 - Stop the engine.
- Disconnect the spark plug caps of each cylinder and remove the spark plugs.
- Attach the compression gauge assembly firmly into one plug hole.

Special Tools - Compression Gauge, 20 kgf/cm² [A]: 57001-221

Compression Gauge Adapter, M14 × 1.25 [B]: 57001-1159

- Ground the spark plugs to the engine.

⚠ WARNING

To avoid fire, do not ground the spark plugs in proximity to the plug holes. Keep the plugs as far away as possible from the plug holes.

- Open the throttle fully. Run the engine by turning the engine switch key several times until the compression gauge stops rising. Read the highest compression value.

Cylinder Compression (MIN) 555 kPa (80 psi) @ Engine Oil Temperature 50 ~ 60°C (122 ~ 140°F), Cranking Speed 500 rpm/5 Seconds

- Repeat the measurement on the other cylinder.
- ★ If the compression is higher than the specified value, the piston rings, cylinder and valves are probably in good condition.
- ★ If the compression is too high, check the following.
 1. Carbon build-up on the piston crown and cylinder head - clean off any carbon on the piston crown and cylinder head.
 2. Cylinder head gasket - use only the proper gasket. The use of a gasket of incorrect thickness will change the compression.
 3. Valve guides and piston rings - rapid carbon accumulation in the combustion chamber may be caused by worn valve guides and/or worn piston oil rings. This may be indicated by white exhaust smoke.
- ★ If the cylinder compression is lower than the (MIN), check the following.
 1. Gas leakage around the cylinder head - replace the damaged gasket with a new one and check the cylinder head warp.
 2. Condition of the valve seating.
 3. Valve clearance.
 4. Piston/cylinder wear, piston seizure.
 5. Piston ring, piston ring groove.

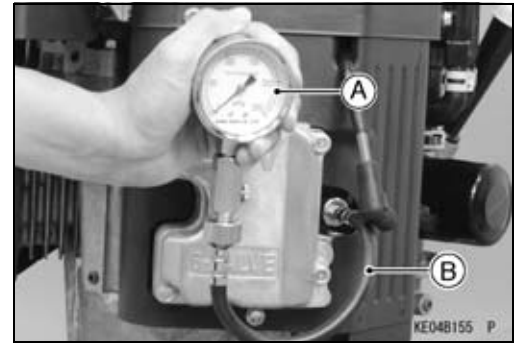

5-8 ENGINE TOP END

Cylinder Head

Cylinder Head Assembly Removal

- Remove:
 - Intake Manifold (see Intake Manifold Removal in the Fuel System chapter)
 - Spark Plugs (see Spark Plug Removal in the Electrical System chapter)
- Unscrew the rocker cover bolts [A], and remove the cover [B] and the gasket.
- When removing the #1, #2 cylinder head, set each piston at the top dead center (T.D.C) of the compression stroke (see Valve Clearance Inspection in the Periodic Maintenance chapter).
- Push out the rocker shafts [A].
- Remove:
 - Rocker Arms [B]
 - Push Rods (see Push Rod Removal)
 - Engine Shroud (see Engine Shroud Removal in the Cooling System chapter)
- Loosen the cylinder head bolts 1/4 turn in the sequence as shown in the figure.

CAUTION

If the above procedure is not followed, the cylinder head may be warped during removal.

- Repeat the sequence until all bolts are removed and lift off the cylinder head assembly.

NOTE

○Mark the push rods and rocker arms so they can be installed in their original position during assembly.

Cylinder Head Assembly Installation

- Clean the mating surfaces of the cylinder heads and cylinders.
- Replace the gaskets with new ones.
- Install the dowel pins [A].
- When installing the #1, #2 cylinder head, set each piston at the top dead center (T.D.C) of the compression stroke (see Valve Clearance Inspection in the Periodic Maintenance chapter).
- Put new gaskets and the cylinder head assemblies on each cylinder, then let the cylinder heads with push rods aligned under the rocker arms.

NOTE

○As the head gaskets are coated with sealing agents, be careful not to damage the surfaces.

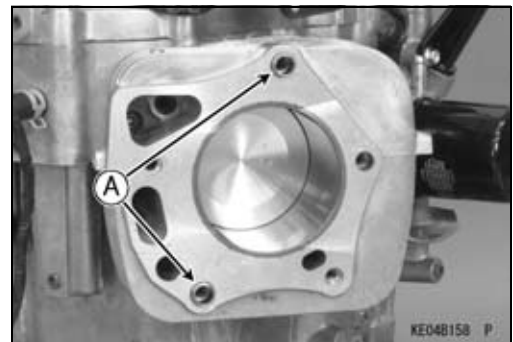
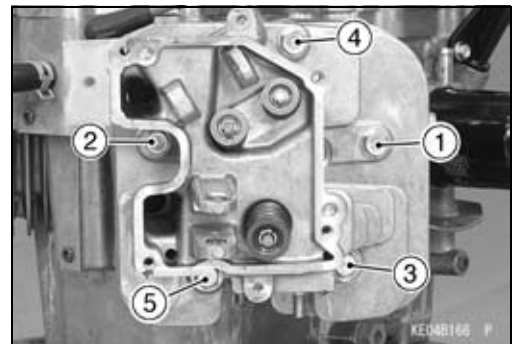
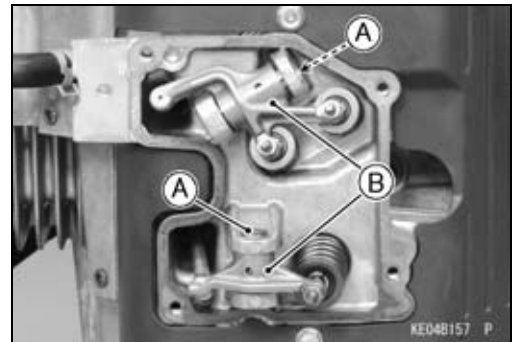
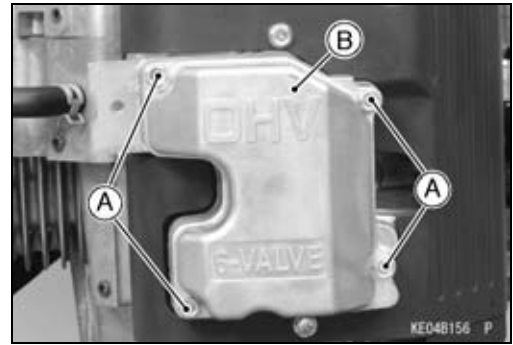

Cylinder Head

- Tighten the cylinder head bolts following the tightening sequence as shown in the figure.

Torque - Cylinder Head Bolts: 46 N-m (4.7 kgf-m, 34 ft-lb)

#1 Cylinder [A]

#2 Cylinder [B]

CAUTION

A torque wrench must be used to assure proper torque. Improper tightening of the head bolts may result in warping of the cylinder head.

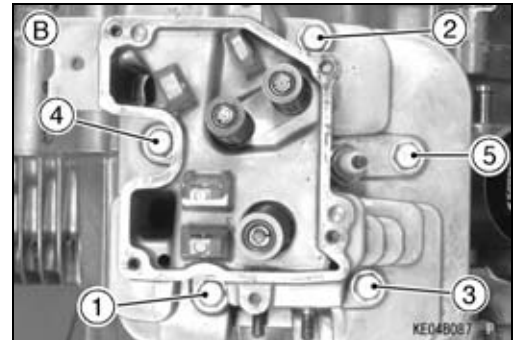
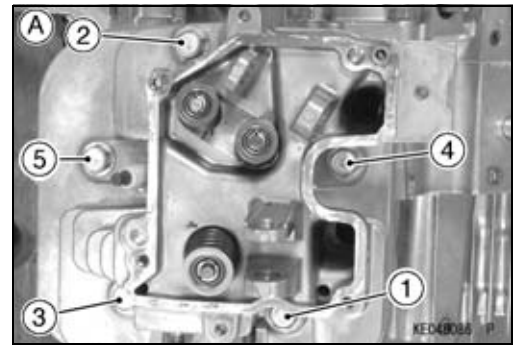

- Install:
 - Engine Shroud (see Engine Shroud Installation in the Cooling System chapter)
 - Push Rods (see Push Rod Installation)
 - Rocker Arms [A]
 - Rocker Shafts [B]
- Check to see that push rod ends are in the hollow of the rocker arms.
- Check and adjust the valve clearance (see Valve Clearance Inspection, Adjustment in the Periodic Maintenance chapter).
- Install the new gaskets and rocker covers.
- Tighten:
 - Torque - Rocker Cover Bolts: 5.9 N-m (0.60 kgf-m, 52 in-lb)**
- Install the removed parts (see appropriate chapters).

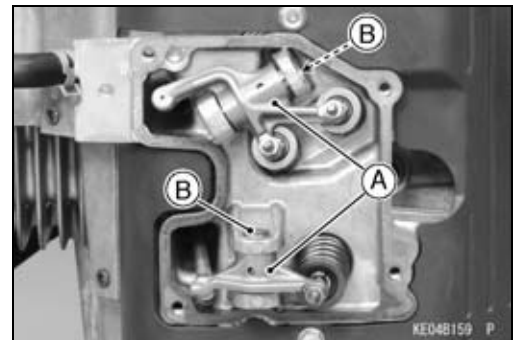

Push Rod Removal

- Set each piston at the T.D.C of the compression stroke.
- Remove the rocker arms (see Cylinder Head Assembly Removal).
- Pull out the push rods [A].

NOTE

○ Mark the push rods and rocker arms so they can be installed in their original position during assembly.

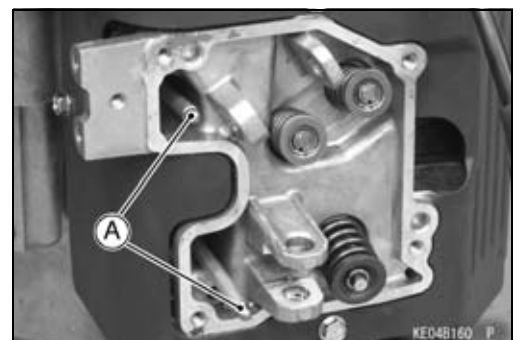

5-10 ENGINE TOP END

Cylinder Head

Push Rod Installation

- Set each piston at the T.D.C of the compression stroke.
- Apply engine oil to the both ends and shaft of the push rod.
- Install the push rods in their original positions of the tappet hollow [A].
- Check that both intake and exhaust push rods on each cylinder are at lowest position on the cam lobes. If the piston is not at the T.D.C of the compression stroke, turn the flywheel clockwise one turn (360°) and reset each piston at the T.D.C of the compression stroke.
- Be sure the end of the push rods are correctly seated on the tappets.
- Install the rocker arm (see Valve Mechanism Removal/Installation).
- Check and adjust the valve clearance (see Valve Clearance Inspection in the Periodic Maintenance chapter).

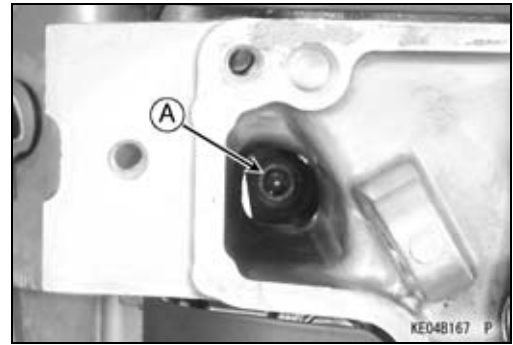

Push Rod Inspection

- Place the push rod on V blocks as far apart as possible, and set a dial gauge [A] on the rod at a halfway point between the blocks. Turn the rod to measure the runout. The difference between the highest and the lowest dial readings is the amount of runout.
- ★ If the runout exceeds the service limit, replace the rod with a new one.

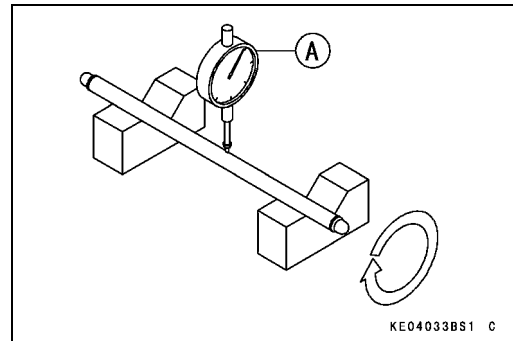

Rocker Arm Push Rod Runout

Service Limit: 0.2 mm (0.008 in.)

Valve Mechanism Removal/Installation

- Remove:
 - Rocker Arms (see Cylinder Head Assembly Removal)
 - Cylinder Head Assembly (see Cylinder Head Assembly Removal)

NOTE

○ When removing the valve mechanism parts, note their position so that they may be reinstalled in their original position during assembly.

- Remove the cylinder head assembly (see Cylinder Head Assembly Removal).
- Support the valve head in the combustion chamber with a suitable block.
- To remove the collets [A], push down the valve retainer [B] with suitable tool and remove the collets.
- Remove the valve retainer, spring [C] and valve [D].

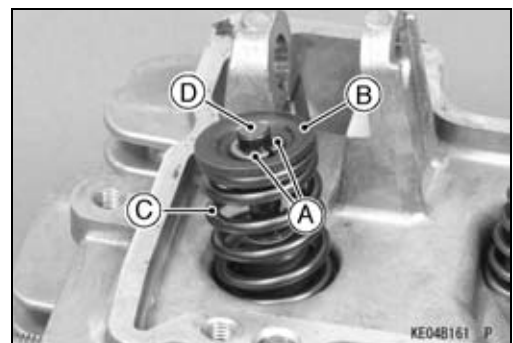

Cylinder Head

- Remove the stem seals [A].

NOTE

- *It is not necessary to remove the stem seal unless it is being replaced.*
- *Valve guide [B] is not replaceable, do not remove it.*

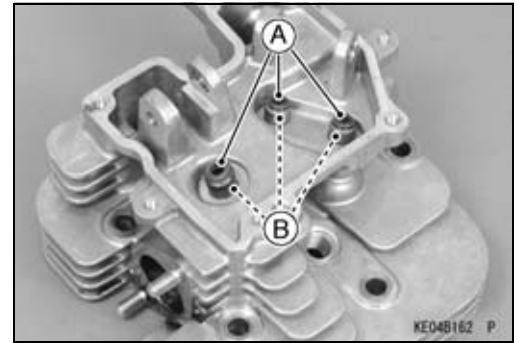

- Apply engine oil to the valve stem to avoid damaging the stem seal.
- Check to see that the valve moves smoothly up and down in the guide.
- Check to see that the valve seats properly in the valve seat [A]. If it does not, repair the valve seat (see Valve Seat Repair in the Periodic Maintenance chapter).
- Valve installation is the reverse of removal.
- Install the cylinder head assembly (see Cylinder Head Assembly Installation).
- Set the each piston at T.D.C of the compression stroke (see Cylinder Head Assembly Installation).

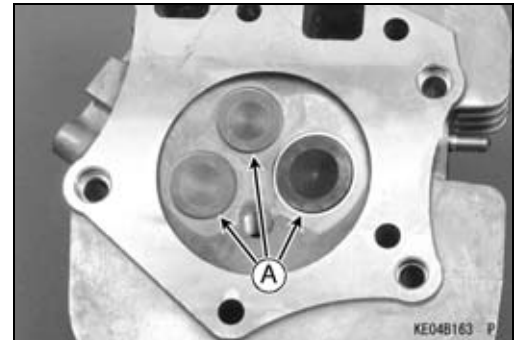

Cylinder Head Cleaning

- Refer to the Cylinder Head Cleaning in the Periodic Maintenance chapter.

Cylinder Head Inspection

- Lay a straightedge [A] across the mating surface of the head at several different points, and measure warp by inserting a thickness gauge [B] between the straightedge and head.
- ★ If warp exceeds the service limit, repair the head by lapping the mating surface with emery paper secured to a surface plate (first No. 200, than No. 400). If the mating surface is badly damaged, replace the cylinder head.

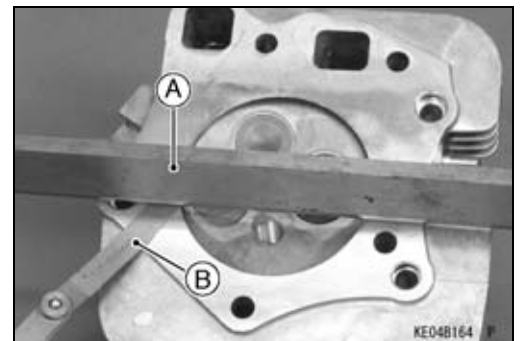

Cylinder Head Warp

Service Limit: 0.05 mm (0.002 in.)

- Check the cylinder head for cracks or other damage.
- Cracks not visible to the eye may be detected by coating the suspected area with mixture of 25% kerosene and 75% light engine oil.
- Wipe the area dry and immediately apply a coating of zinc oxide dissolved in wood alcohol. If a cracks is present, the coating will become discolored at the defective area.
- If a cracks is present in the cylinder head, replace it.
- Inspect the mating surface for burrs and nicks.

5-12 ENGINE TOP END

Cylinder Head

Rocker Arm Inspection

- Measure the diameter [A] of the rocker shafts with a micrometer at several points of bearing the rocker arm.
- ★ If the outside diameter is less than the service limit, replace the rocker shaft.

Rocker Shafts Outside Diameter

Service Limit:

Intake, Exhaust 11.95 mm (0.470 in.)

- Clean and inspect the rocker arm where it touches the push rod and valve stem.
- ★ If the contact points [A] are worn or damaged, replace the rocker arm.
- Measure the inside diameter [B] of the rocker arm at several points using a dial bore gauge or inside micrometer.
- ★ If the inside diameter is more than the service limit, replace the rocker arm.

Rocker Arm Inside Diameter

Service Limit:

Intake, Exhaust 12.05 mm (0.474 in.)

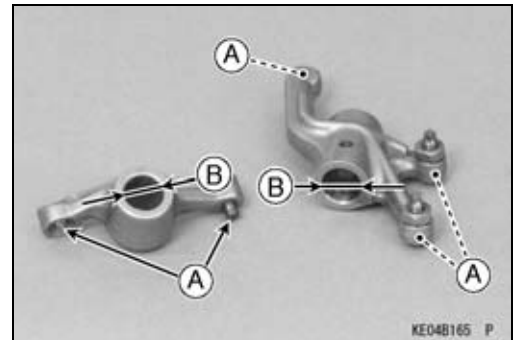
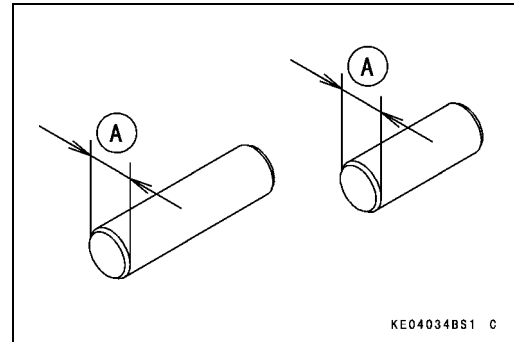

Valves

Valve Clearance Inspection

- Refer to the Valve Clearance Inspection in the Periodic Maintenance chapter.

Valve Clearance Adjustment

- Refer to the Valve Clearance Adjustment in the Periodic Maintenance chapter.

Valve Seat Inspection

- Refer to the Valve Seat Inspection in the Periodic Maintenance chapter.

Valve Seat Repair

- Refer to the Valve Seat Repair in the Periodic Maintenance chapter.

Valve Head Thickness

- Remove the valve (see Valve Mechanism Removal/Installation).
- Measure the valve head thickness.
- ★ If the valve head thickness (valve margin) [A] is less than the service limit, replace the valve with a new one.

Valve Head Thickness Service Limit:

Intake, Exhaust 0.4 mm (0.016 in)

Valve Stem Runout

- Support the valve in V blocks at each end of the stem.
- Position a dial gauge perpendicular to the stem.
- Turn the valve and read the variation on the dial gauge.
- ★ If the stem runout is greater than service limit, replace the valve.

Valve Stem Runout Service Limit:

Intake, Exhaust TIR 0.05 mm (0.002 in.)

Valve Stem Diameter

- Measure the diameter of the valve stem [A] in two directions at right angles, at four different positions on the stem.
- ★ If any single measurement is less than the service limit, replace the valve with a new one.

Valve Stem Diameter Service Limit:

Intake: 5.95 mm (0.234 in.)

Exhaust: 6.93 mm (0.273 in.)

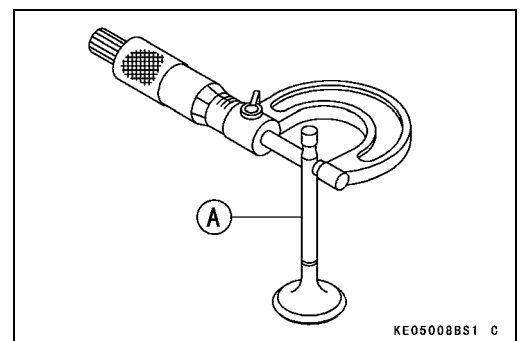
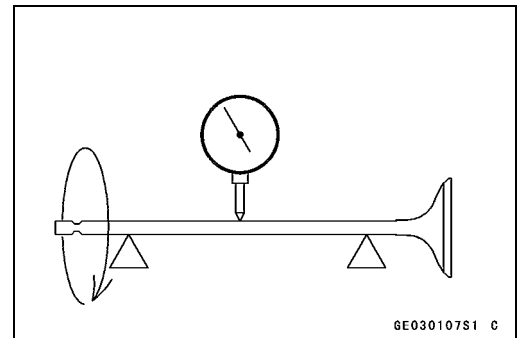
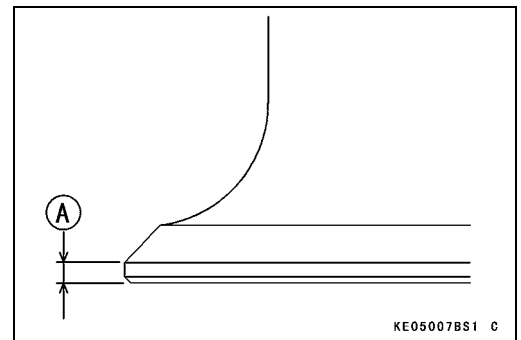

5-14 ENGINE TOP END

Valves

Valve Guide Inside Diameter

- Use a small bore gauge or a micrometer to measure the inside diameter [A] of the valve guide [B] at three positions down the guide length.
- ★ If the measurement is more than the service limit, replace the cylinder head with a new one.

Valve Guide Inside Diameter

Standard:

Intake	6.000 ~ 6.015 mm (0.2362 ~ 0.2368 in.)
Exhaust	7.000 ~ 7.015 mm (0.2756 ~ 0.2762 in.)

Service Limit:

Intake	6.08 mm (0.239 in.)
Exhaust	7.08 mm (0.279 in.)

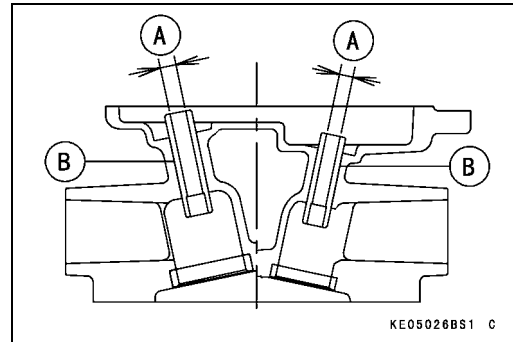

Valve Spring Inspection

- Inspect the valve spring for pitting, cracks, rusting, and burns. Replace the spring with a new one if necessary.
- Measure the free length [A] of the spring.
- ★ If the measurement is less than the service limit, replace the spring with a new one.

Valve Spring Free Length

Service Limit:

Intake	31.0 mm (1.22 in.)
Exhaust	34.5 mm (1.36 in.)

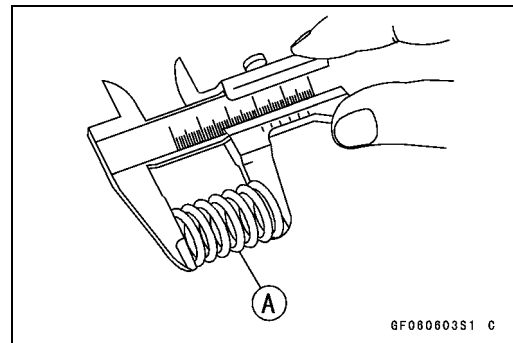

Cylinder, Piston

Piston Removal

- Remove:
 - Cylinder Head Assembly (see Cylinder Head Assembly Removal)
 - Crankcase Cover (see Crankcase Cover Removal in the Camshaft/Crankshaft chapter)
 - Camshaft (see Camshaft, Tappet Removal in the Camshaft/Crankshaft chapter)
- Turn the crankshaft to expose the connecting rod cap bolts [A].
- Remove the bolts and take off the connecting rod caps [B].

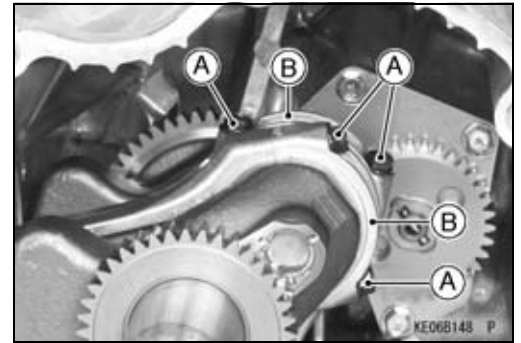

NOTE

○ Note the positions of the connecting rod caps for re-installing the caps.

- Scrape the carbon deposits from the cylinder head with a suitable tool before the piston and connecting rod are pulled out.
- Push the connecting rod end into the cylinder, and pull the piston and connecting rod out of the cylinder.

CAUTION

Note the location of the arrow match mark [A] on the piston head in relation to "K" Mark [B] on the connecting rod.

No.1 cylinder "K" Mark on the connecting rod is face to face with No.2 cylinder "K" Mark on the connecting rod. Keep parts together as a set.

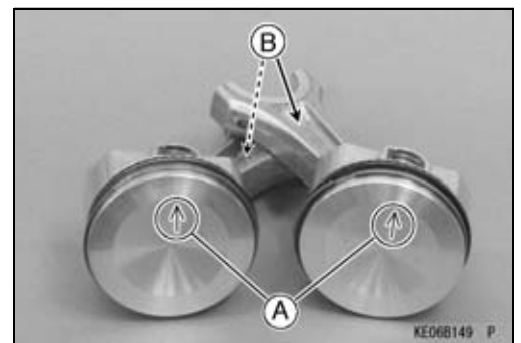

- Remove one of the piston pin snap rings [A] with needle nose pliers [B].

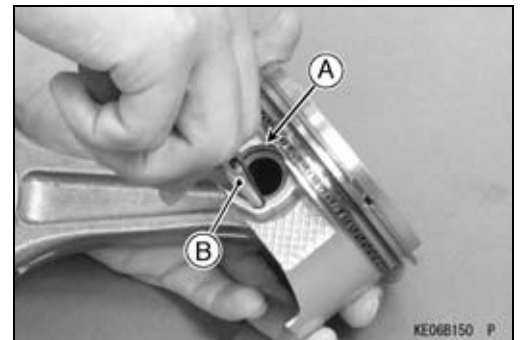

- Remove the piston by pushing the piston pin [A] out the side from which the snap ring was removed.

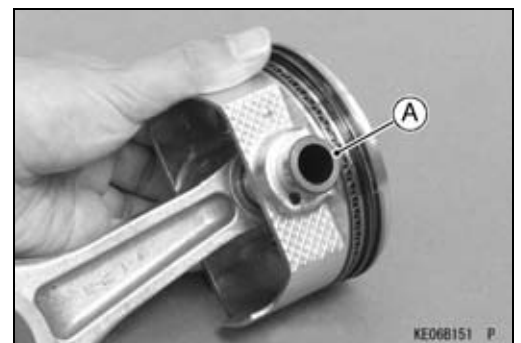

5-16 ENGINE TOP END

Cylinder, Piston

- Remove the top and second rings with piston ring pliers.

Special Tool - Piston Ring Pliers: 57001-115

- If the special tool is not available, carefully spread the ring opening with your thumbs, then push up to the opposite side of the ring [A] to remove it.
- Remove the 3-piece oil ring with your thumbs in the same manner.

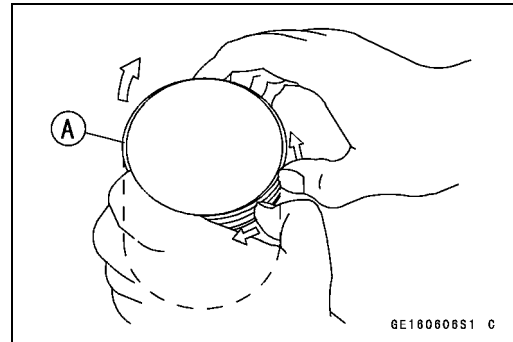

Piston Installation

- Install the expander [A] in the piston oil ring groove so that the expander ends [B] touch together, never overlap them.
- Install the upper and lower steel rails. There is no UP or Down to the rails. They can be installed either way.

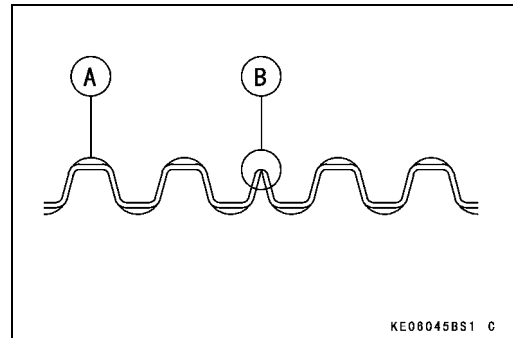

- Do not mix up the top and second rings.
- With the marked side facing up, install the second ring [A] and top ring [B] in that order.
- The rings should turn freely in the grooves.

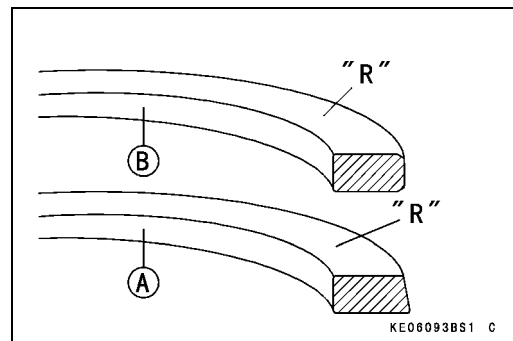

- Align the piston and rings with the piston ring end gap as shown.

Arrow Match Marks [A]

Top Ring End Gap, Upper Steel Rail End Gap [B]

45° [C]

Second Ring End Gap, Lower Steel Rail End Gap [D]

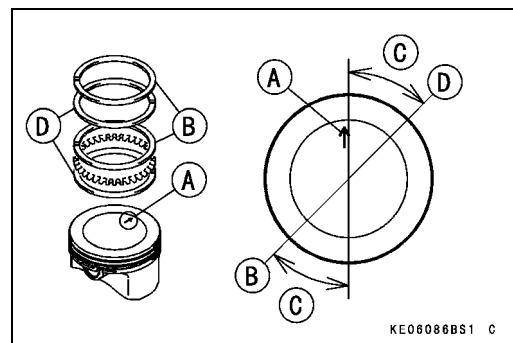

- Apply engine oil to the piston pins.
- Assemble the pistons onto the connecting rods as follow.
 - No.1 Cylinder Piston; align the arrow mark on the piston head with opposite "K" Mark on the connecting rod to face the flywheel side.
 - No.2 Cylinder Piston; align the arrow mark on the piston crown with the "K" mark on the connecting rod.
 - Both marks must face the flywheel side.
 - No.1 cylinder Piston [A]
 - No.2 cylinder Piston [B]
 - Arrow Marks [C]
 - "K" Mark [D]
 - Opposite "K" Mark [E]

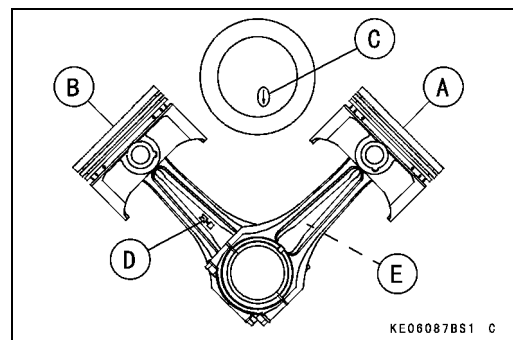

Cylinder, Piston

- Fit a new piston pin snap ring into the side of the piston so that the ring opening [A] does not coincide with the notch [B] in the edge of the piston pin hole.
- When installing a piston pin snap ring, compress it only enough to install it and no more.

CAUTION

Do not reuse the snap rings, as removal weakens and deforms them. They could fall out and score the cylinder wall.

- Apply engine oil to the piston skirt and the cylinder bore.
- ★ Using the piston ring compressor grip [A] and the belt [B], lightly tap the top of the piston with a plastic mallet [C] to insert the piston and connecting rod into the cylinder.

**Special Tools - Piston Ring Compressor Grip: 57001-1095
Piston Ring Compressor Belt, $\phi 80 \sim \phi 91$:
57001-1320**

- Insert the piston and connecting rod so that the arrow mark [A] on the top of the piston is facing the flywheel side [B].

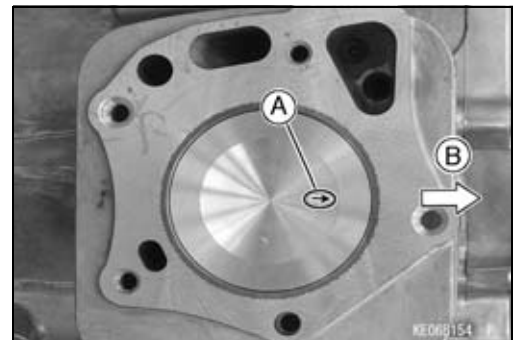
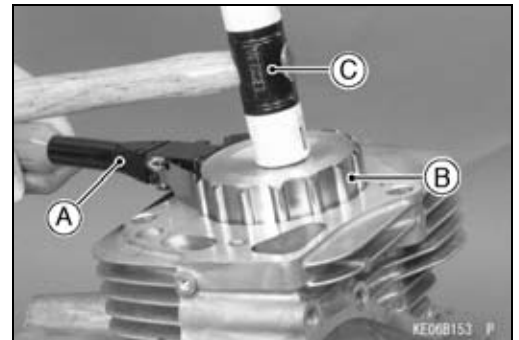
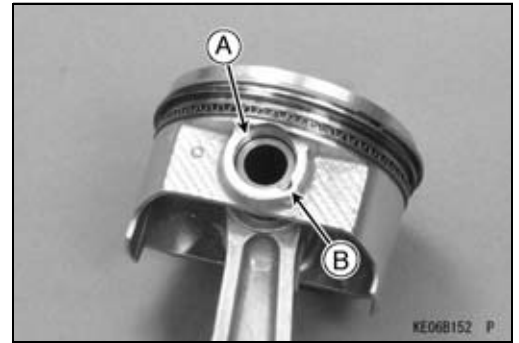

CAUTION

The connecting rod and the connecting rod big end cap are machined at the factory in the assembled state, so they must be replaced together as a set.

- Apply molybdenum disulfide oil solution oil to the inner surface [A] of the connecting rod big end [B] and caps [C].
- The molybdenum disulfide oil solution is a mixture of engine oil and molybdenum disulfide grease with a weight ratio (10:1).
- Install the connecting rod big end caps on their original position on each connecting rod big ends.
- Apply a thin layer of engine oil to the thread [D] and seating surface [E] of the cap bolts.
- Tighten:

**Torque - Connecting Rod Big End Cap Bolts: 20.6 N·m
(2.10 kgf·m, 15.2 ft·lb)**

- Install:
 - Camshaft (see Camshaft, Tappet Installation in the Camshaft/Crankshaft chapter)
 - Crankcase Cover (see Crankcase Cover Removal in the Camshaft/Crankshaft chapter)

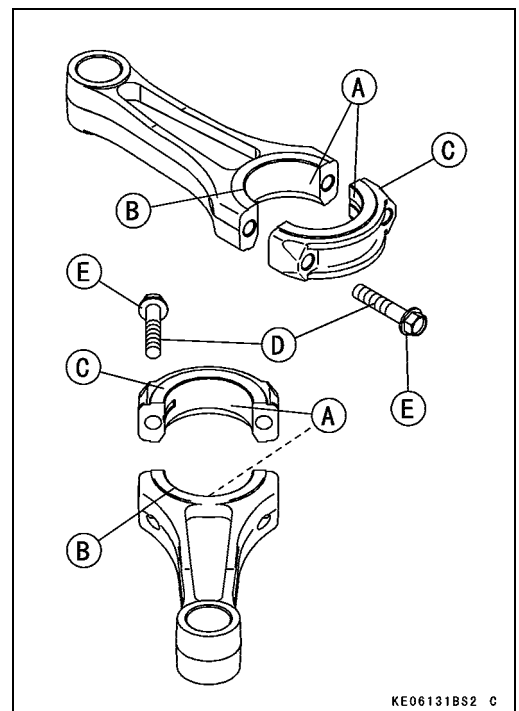

5-18 ENGINE TOP END

Cylinder, Piston

Piston/Cylinder Seizure

- In case of seizure, remove the pistons (see Piston Removal).
- Visually inspect the cylinder and pistons for damage.
- ★ If there is only light damage, repair the damaged piston surface with #400 emery cloth. Remove the small aluminum deposits from the cylinder with #400 emery cloth or light honing.
- ★ If the damage is severe, replace the crankcase and pistons.

Piston Cleaning

- Remove the piston and the piston rings (see Piston Removal).

CAUTION

Never clean the piston head with the engine assembled. Carbon particles will fall between the piston and cylinder, and damage the crankshaft bearings.

- Scrape the carbon off the piston head.
- Use the scraping tools [A] carefully. Do not gouge the piston head. To avoid gouging, use scrapers that are made of a material that will not cause damage.
- Clean the piston ring grooves [A] with a broken piston ring or other suitable tools.

CAUTION

Be careful not to widen the ring grooves. Damaged ring grooves will require piston replacement.

Piston Ring and Ring Groove Wear

- Clean the piston (see Piston Cleaning).
- Visually inspect the piston rings and ring grooves.
- ★ If the piston rings are worn unevenly or damaged, replace them with new ones.
- ★ If the ring grooves are worn unevenly or damaged, replace both the piston and the piston rings with new ones.
- Measure the clearance between the top and second rings and their grooves using a thickness gauge [A] as shown in the figure.
- ★ If the piston ring/groove clearance is greater than the service limit, replace the piston with a new one.

Piston Ring/Groove Clearance

Service Limit:

Top	0.14 mm (0.0055 in.)
Second	0.14 mm (0.0055 in.)

NOTE

- The oil ring is a three piece assembled ring. It is difficult to measure the ring groove clearance and thickness, visually inspect only.

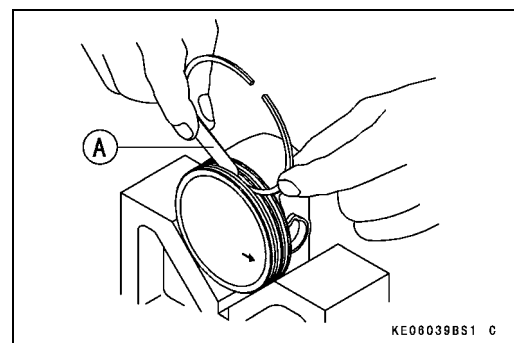
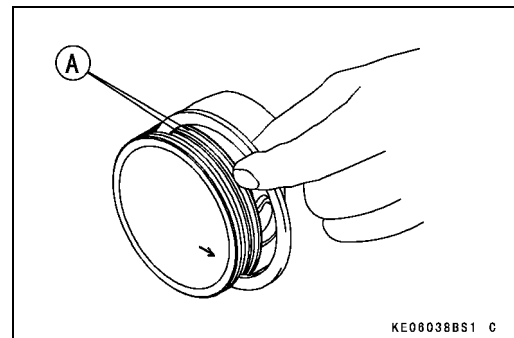
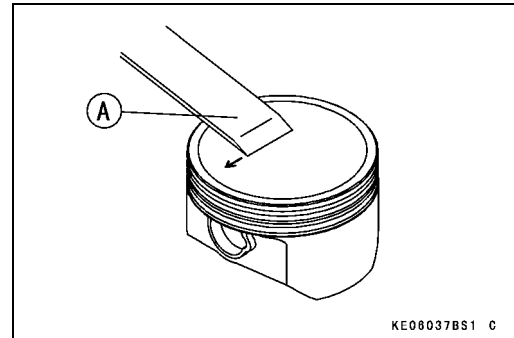

Cylinder, Piston

- Measure the piston ring thickness [A].
- Use a micrometer to measure at several points around the rings.
- ★ If any of the measurement are less than the service limit, replace the entire set of rings with new ones.

Piston Ring Thickness

Service Limit

Top	1.9 mm (0.075 in.)
Second	1.9 mm (0.075 in.)

NOTE

- When using new rings in a used piston, check for uneven groove wear. The rings should fit perfectly parallel to the groove sides. If not, replace the piston with a new one.

Piston Ring End Gap

- Remove the piston rings (see Piston Removal).
- Push each ring (one at a time) in the cylinder bore to a point close to the bottom of the cylinder bore.
- Use the piston to push it in to be sure it is square.
- Measure the gap [A] between the ends of the ring [B] with a thickness gauge.
- ★ If the end gap of any ring is greater than the service limit, replace the entire set of rings with new ones.

Piston Ring End Gap

Service Limit:

Top	0.7 mm (0.028 in.)
Second	0.8 mm (0.031 in.)
Oil	1.0 mm (0.039 in.)

Piston Pin, Piston Pin Hole, and Connecting Rod Wear

- Remove the piston pin (see Piston Removal).
- Measure the outside diameter of the piston pin with a micrometer at several points.
- ★ If the outside diameter is less than service limit, replace the piston pin with a new one.

Piston Pin Outside Diameter

Service Limit: 20.96 mm (0.825 in.)

- Measure the inside diameter [A] of the piston pin hole at several points on both side. Use a dial bore gauge.
- ★ If the inside diameter is greater than the service limit, replace the piston with a new one.

Piston Pin Hole Inside Diameter

Service Limit: 21.08 mm (0.830 in.)

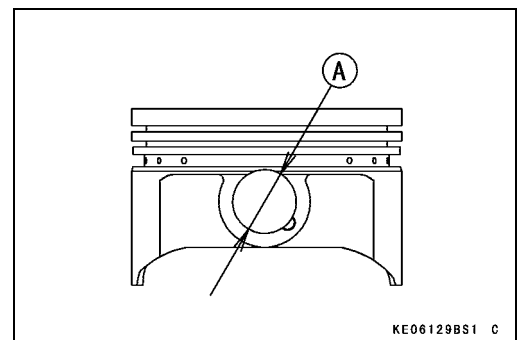
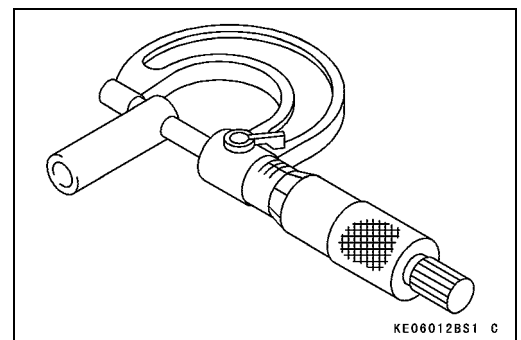
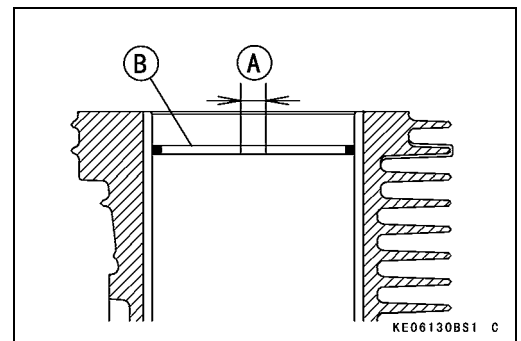
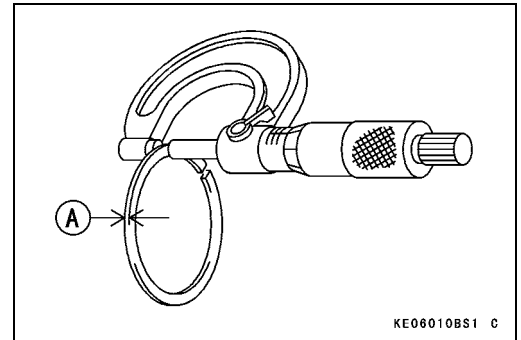

5-20 ENGINE TOP END

Cylinder, Piston

- Measure the inside diameter [A] of the connecting rod small end at several points. Use a dial bore gauge.
- ★ If the inside diameter is more than the service limit, replace the connecting rod with a new one.

Connecting Rod Small End Inside Diameter

Service Limit: 21.06 mm (0.829 in.)

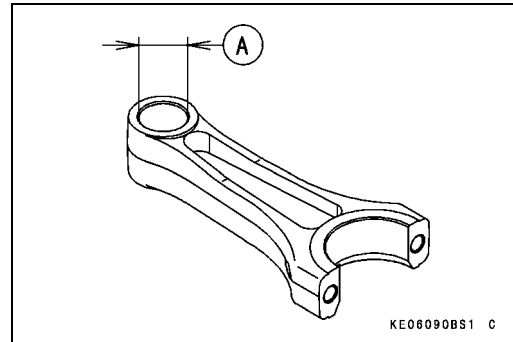

Piston Diameter

- Measure the outside diameter [A] of the piston 7 mm (0.28 in.) up [B] from the bottom of the piston at a right angle to the direction of the piston pin hole.
- ★ If the measurement is less than the service limit, replace the piston with a new one.

Piston Diameter

Service Limit: 88.93 mm (3.501 in.)

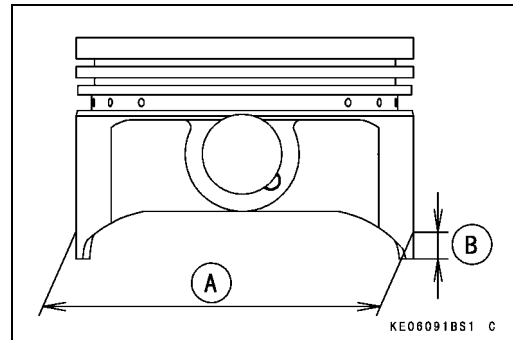

Cylinder Inside Diameter

- Clean and measure the cylinder inside diameter.
- Use a cylinder gauge to measure front-to-back and side-to-side at the points as shown in the figure.
- ★ If any of the cylinder inside diameter measured value is greater than the service limit, replace the crankcase with a new one.
 - 10 mm [A]
 - 55 mm [B]
 - 25 mm [C]

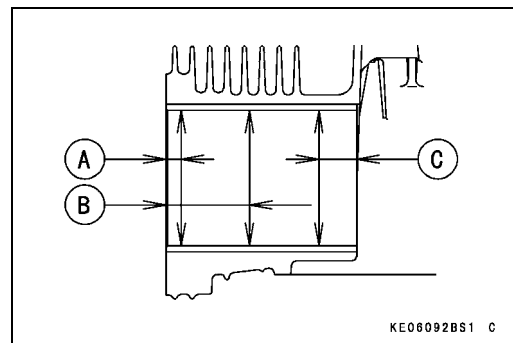

Cylinder Inside Diameter

Standard:

Standard Cylinder	89.13 ~ 89.15 mm (3.509 ~ 3.510 in.)
0.50 mm Oversize	89.63 ~ 89.65 mm (3.529 ~ 3.530 in.)

Service Limit:

Standard Cylinder	89.23 mm (3.513 in.)
0.50 mm Oversize	89.73 mm (3.534 in.)

Cylinder Inside Diameter Out Round

Service Limit: 0.05 mm (0.002 in.)

Cylinder, Piston

Cylinder Boring and Honing

Always resize to exactly 0.5 mm (0.02 in.) over the standard bore size. If this is done accurately, the stock oversize rings and piston will fit perfectly and proper clearance will be maintained. Resizing the cylinder bore can be done by reliable repair shop or by using a drill press and honing tool. Use the stone recommended by the hone manufacturer to produce correct cylinder wall finish. Machine-bore first, the bore diameters should be shown in the table.

Final Boring Bore Diameter

Oversize	Final Boring Bore Diameter
0.50 mm	89.61 ~ 89.63 mm (3.528 ~ 3.529 in.)

Final Bore Diameter

Oversize	Final Bore Diameter
0.50 mm	89.63 ~ 89.65 mm (3.529 ~ 3.530 in.)

Change to a honing stone for finishing, the final bore diameter should be as shown in the table. Be sure the correct stone is used and the stone is not worn.

- Clean the cylinder at the top and bottom of the cylinder to remove burns and pieces of the base and head gasket.
- Anchor the cylinder (block) on the drill press table before honing.
- Align the center of the cylinder bore to the press center. Set the press to operate from 200 ~ 250 rpm.
- Connect the drive shaft to the hone and set the stop on the drill press so the hone can only extend 20 ~ 25 mm (0.8 ~ 1.0 in.) above the top or below the bottom of the cylinder liner.
- Rotate the adjusting nut (knob) on the hone until the stones contact snugly against the cylinder wall at the narrowest point. Do not force.
- Turn the stone by hand. If you cannot turn it, the stone is too tight. Loosen the hone until it can be turned by hand.
- Be sure that the cylinder and hone are centered and aligned with the drive shaft and drill spindle.
- Pour honing oil inside of the cylinder during the honing operation. Start the drill press. Move the hone up and down in the cylinder approximately 20 cycles-per-minute.
- Check the diameter of the cylinder bore regularly during honing, using an inside micrometer.

Lubrication System

Table of Contents

- Exploded View 6-2
- Engine Oil Flow Chart..... 6-4
- Specifications 6-5
- Special Tools 6-6
- Engine Oil, Oil Filter and Oil Cooler..... 6-7
 - Engine Oil Level Inspection 6-7
 - Engine Oil Change..... 6-7
 - Oil Filter Removal 6-7
 - Oil Filter Installation 6-7
 - Oil Cooler Removal..... 6-7
 - Oil Cooler Installation..... 6-7
 - Oil Cooler Fin Cleaning..... 6-7
- Pressurized Lubrication System..... 6-8
 - Oil Pressure Measurement 6-8
- Oil Pump, Relief Valve..... 6-9
 - Oil Pump, Relief Valve Removal 6-9
 - Oil Pump , Relief Valve Installation 6-9
 - Oil Pump, Relief Valve Inspection..... 6-10
- Oil Screen..... 6-12
 - Oil Screen Removal 6-12
 - Oil Screen Installation..... 6-12
 - Cleaning and Inspection 6-12

6-2 LUBRICATION SYSTEM

Exploded View

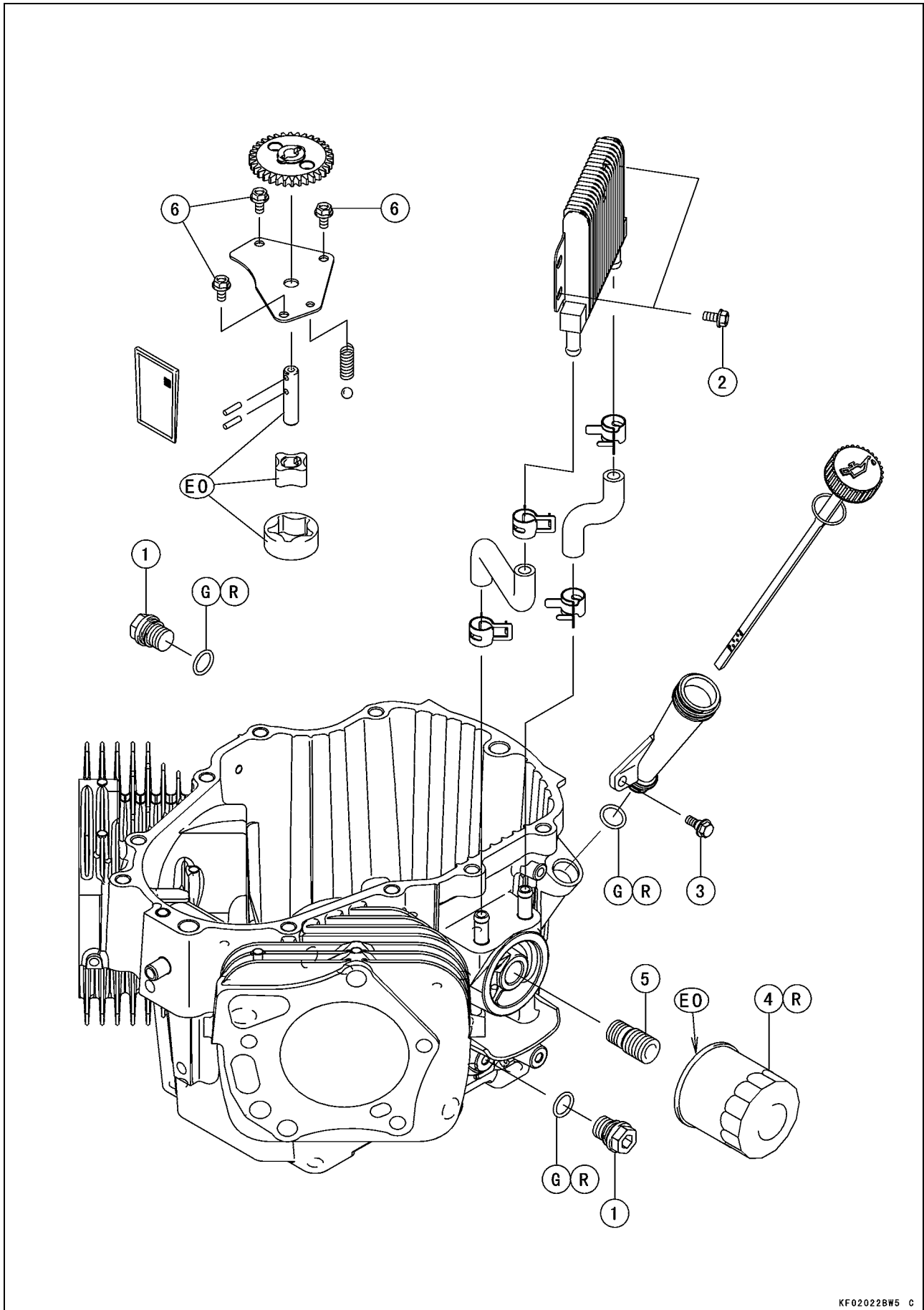

LUBRICATION SYSTEM 6-3

Exploded View

No.	Fastener	Torque			Remarks
		N-m	kgf-m	ft-lb	
1	Engine Oil Drain Plugs	6.9	0.70	61 in-lb	
2	Oil Cooler Bolts	5.9	0.60	52 in-lb	
3	Oil Filler Mounting Bolt	5.9	0.60	52 in-lb	
4	Oil Filter	11.8	1.2	104 in-lb	R
5	Oil Filter Joint Pipe	6.9	0.70	61 in-lb	
6	Oil Pump Cover Plate Bolts	5.9	0.60	52 in-lb	

EO: Apply engine oil.

G: Apply grease.

R: Replacement Parts

6-4 LUBRICATION SYSTEM

Engine Oil Flow Chart

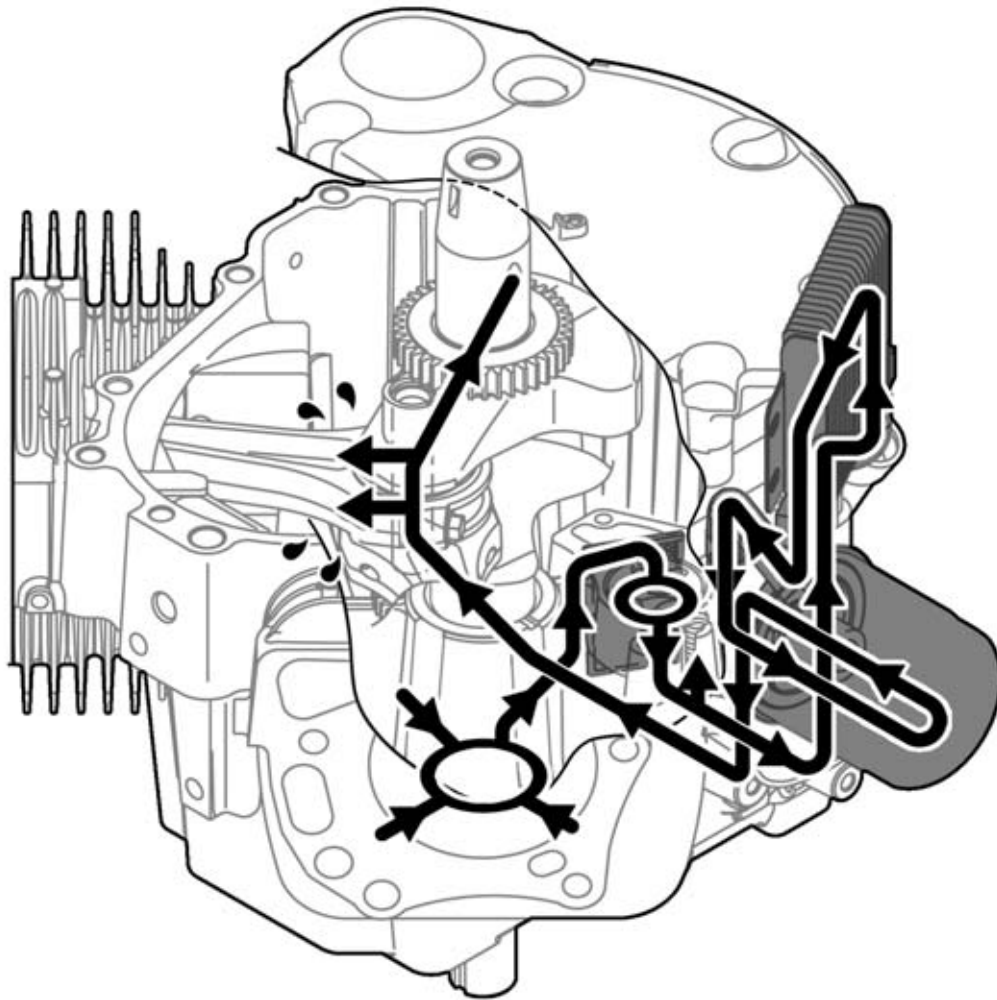
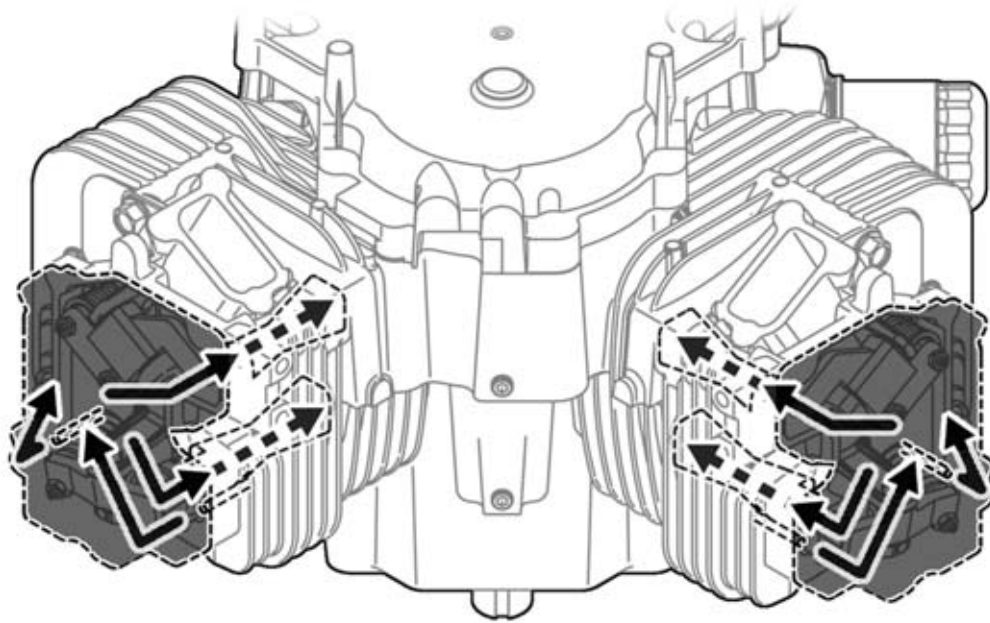

LUBRICATION SYSTEM 6-5

Specifications

Item	Standard
Engine Oil	
Grade	SF, SG, SH, SJ or SL class
Viscosity	SAE40, SAE30, SAE10W-30/SAE10W-40, or SAE5W-20
Capacity	1.7 L (1.8 US qt) (When filter is not removed) 1.9 L (2.0 US qt) (When filter is removed)
Level	Operating range (grid area (ADD and FULL)) on dipstick
Oil Pressure	294 to 490 kPa (43 to 71 psi): Engine oil temperature 50°C to 60°C (122 ~ 144°F)

Item	Service Limit
Oil Pump	
Inner and Outer Rotor Clearance	0.2 mm (0.008 in.)
Outer Rotor Outside Diameter	40.47 mm (1.593 in.)
Outer Rotor Thickness	14.94 mm (0.5882 in.)
Pump Housing Inside Diameter	40.801 mm (1.6063 in.)
Pump Housing Depth	15.16 mm (0.5968 in.)
Pump Shaft Outside Diameter	10.923 mm (0.43004 in.)
Pump Shaft Bearing Inside Diameter	11.068 mm (0.43575 in.)
Relief Valve Spring Free Length	20.6 mm (0.811 in.)

6-6 LUBRICATION SYSTEM

Special Tools

Oil Pressure Gauge, 10 kgf/cm²:
57001-164

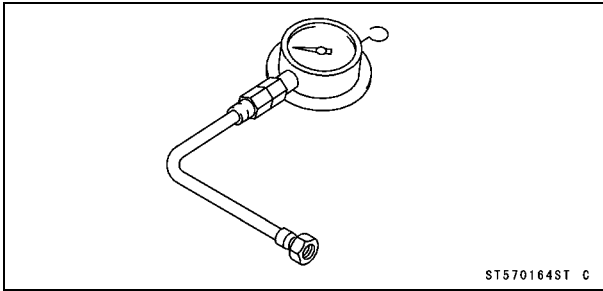

Oil Pressure Gauge Adapter, PT 1/8":
57001-1033

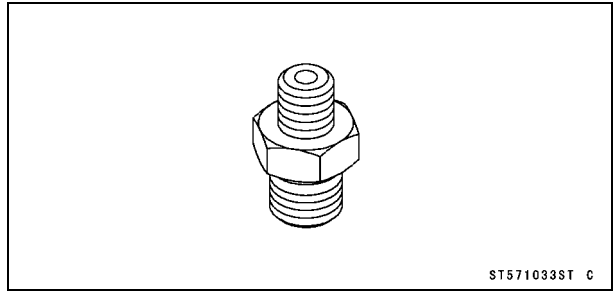

Engine Oil, Oil Filter and Oil Cooler

CAUTION

Engine operation with insufficient, deteriorated, or contaminated engine oil will cause accelerated wear and may result in engine seizure and accident.

Engine Oil Level Inspection

- Refer to the Engine Oil Level Inspection in the Periodic Maintenance chapter.

Engine Oil Change

- Refer to the Engine Oil Change in the Periodic Maintenance chapter.

Oil Filter Removal

- Refer to the Oil Filter Replacement in the Periodic Maintenance chapter.

Oil Filter Installation

- Refer to the Oil Filter Replacement in the Periodic Maintenance chapter.

Oil Cooler Removal

- Drain the engine oil (see Engine Oil Change in the Periodic Maintenance chapter).
- Remove the oil cooler bolts [A] and free the oil cooler [B].
- Remove the oil hose clamps [C], and take off the oil hoses [D] from the crankcase.

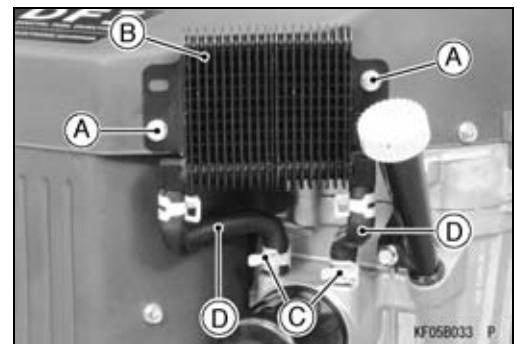

Oil Cooler Installation

- Install the oil cooler.
 - Torque - Oil Cooler Bolts: 5.9 N·m (0.60 kgf·m, 52 in·lb)**
- Connect the oil hoses with the clamps.

Oil Cooler Fin Cleaning

- Refer to the Oil Cooler Fin Cleaning in the Periodic Maintenance chapter.

6-8 LUBRICATION SYSTEM

Pressurized Lubrication System

The engine lubrication circuit is a pressurized system consisting of a positive displacement pump which picks up oil through a filter screen from the crankcase. The oil is pumped to a replaceable oil filter cartridge, through the engine's oil passages to lubricate internal components, and return to the crankcase. A pressure relief valve is used between the oil pump and oil filter to relieve excessive oil pressure by returning excess oil to the crankcase (see Oil Flow Chart).

Oil Pressure Measurement

- Remove the oil passage plug [A] from the crankcase.

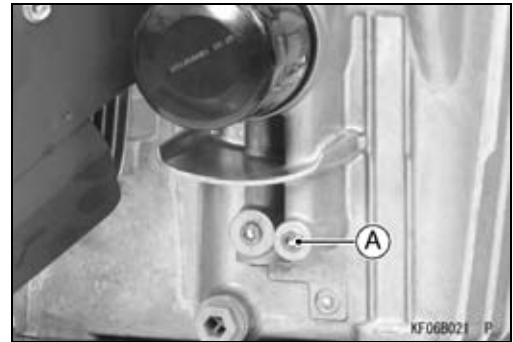

- Install the oil pressure gauge adapter [A] and oil pressure gauge [B].

Special Tools - Oil Pressure Gauge, 10 kgf/cm²: 57001-164
Oil Pressure Gauge Adapter, PT 1/8: 57001-1033

- Run the engine and warm up thoroughly.
- Run the engine at 3 200 r/min (rpm) and read the oil pressure gauge.
- ★ If the oil pressure is below the specification, inspect the oil pump and relief valve (see Oil Pump, Relief Valve Inspection).
- ★ If the oil pump and relief valve are not at fault, inspect the rest of the lubrication system.

Oil Pressure

294 to 490 kPa (43 to 71 psi)

Measurement Condition

Engine Oil Temperature: 50 ~ 60°C (122 ~ 144°F)

- Stop the engine.
- Remove the oil pressure gauge and adapter.

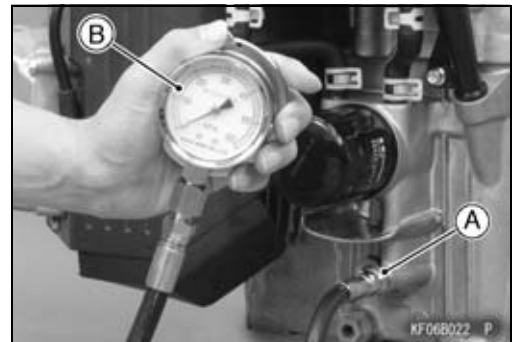

⚠ WARNING

Take care against burns from hot engine oil that will drain through the oil passage when the gauge adapter is removed.

- Apply a non-permanent locking agent to the oil passage plug, and tighten it.

Torque - Oil Passage Plug: 3.9 N·m (0.40 kgf·m, 35 in·lb)

Oil Pump, Relief Valve

Oil Pump, Relief Valve Removal

- Remove:
 - Crankshaft (see Crankshaft Removal in the Camshaft/Crankshaft chapter)
 - Bolts [A]
- Take out the pump cover plate [B], pump gear [C] and pump shaft [D] as a set.
- Remove the pins [A], oil pump cover plate [B] and oil pump gear [C] from the pump shaft [D].

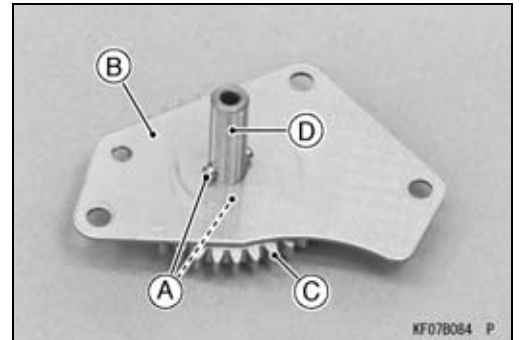
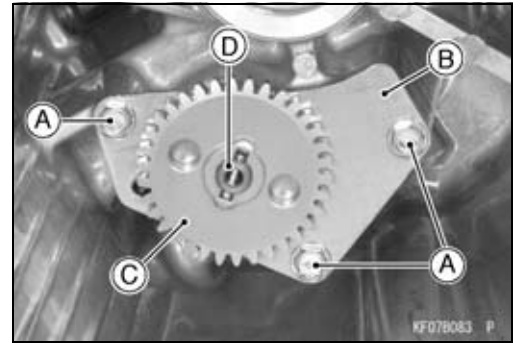

- Remove:
 - Inner Rotor [A]
 - Outer Rotor [B]
 - Spring [C]
 - Relief Valve Ball [D]

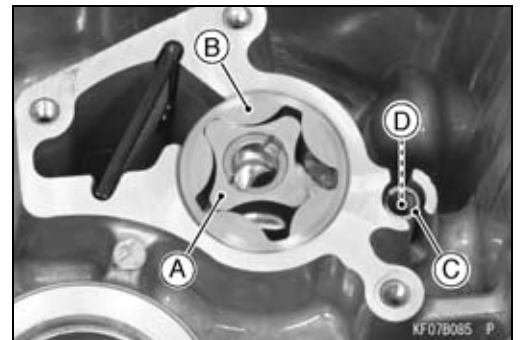

Oil Pump, Relief Valve Installation

- Assemble the following parts as shown in the figure.
 - Pins [A]
 - Oil Pump Gear [B]
 - Oil Pump Cover Plate [C]
 - Pump Shaft [D]

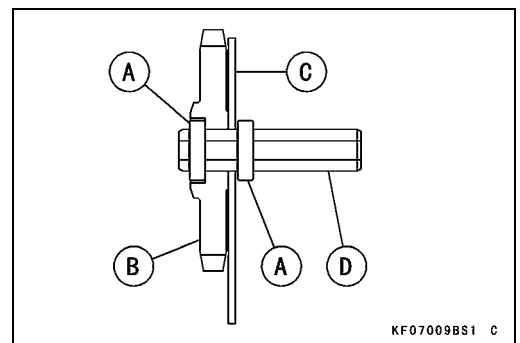

- Fill the rotor housing with engine oil for initial lubrication.
- Install the outer [A] and inner rotor [B].
- Install the relief valve ball and spring in position.
- Fit the pin [C] of the oil pump parts assembly [D] into the slots [E] in the inner rotor.

NOTE

○ When installing the pump parts assembly align the $\phi 6$ mm ($\phi 0.2$ in.) hole [F] on the cover plate with center of the relief valve [G].

- Tighten:
 - Torque - Oil Pump Cover Plate Bolts: 5.9 N-m (0.60 kgf-m, 52 in-lb)

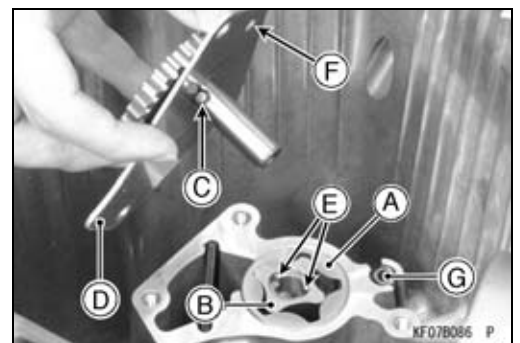

6-10 LUBRICATION SYSTEM

Oil Pump, Relief Valve

Oil Pump, Relief Valve Inspection

- Remove the oil pump parts assembly (see Oil Pump, Relief Valve Removal).
- Visually inspect the pump gear, outer and inner rotor, and cover plate.
- ★ If there is any damage or uneven wear, replace them with new ones.
- Check the clearance [A] between the inner and outer rotor with a feeler gauge. Measure the clearance between the high point of the inner rotor and the high point of the outer rotor.
- ★ If the measurement exceed the service limit, replace the rotors as a set with new ones.

Inner and Outer Rotor Clearance

Service Limit: 0.2 mm (0.008 in.)

- Measure the outside diameter [A] of the outer rotor with a micrometer at several points.
- ★ If the rotor diameter is less than the service limit, replace both the inner and outer rotor with new ones.

Outer Rotor Outside Diameter

Service Limit: 40.47 mm (1.593 in.)

- Measure the thickness [B] of the outer rotor with a micrometer at several points.
- ★ If the rotor thickness is less than the service limit, replace both the inner and outer rotor with new ones.

Outer Rotor Thickness

Service Limit: 14.94 mm (0.5882 in.)

- Measure the inside diameter [A] of the pump housing with a inside micrometer at several points.
- ★ If the inside diameter is more than the service limit, replace the crankcase cover with a new one.

Pump Housing Inside Diameter

Service Limit: 40.801 mm (1.6063 in.)

- Measure the depth [B] of the pump housing with a depth micrometer at several points.
- ★ If any of measurement is more than the service limit, replace the crankcase cover with a new one.

Pump Housing Depth

Service Limit: 15.16 mm (0.5968 in.)

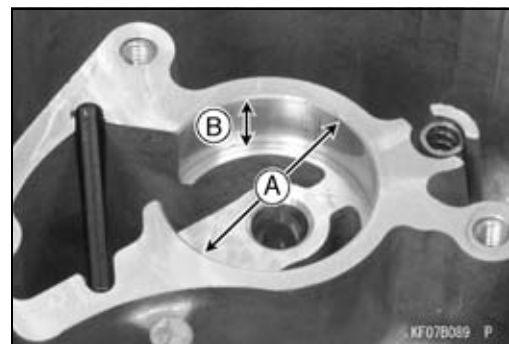
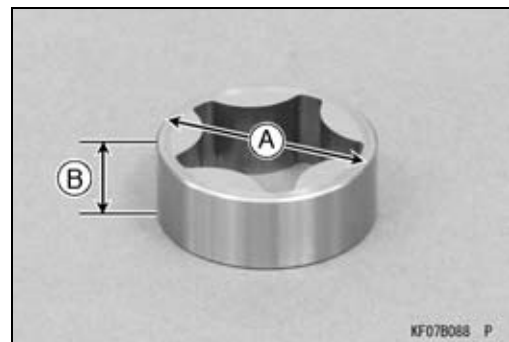
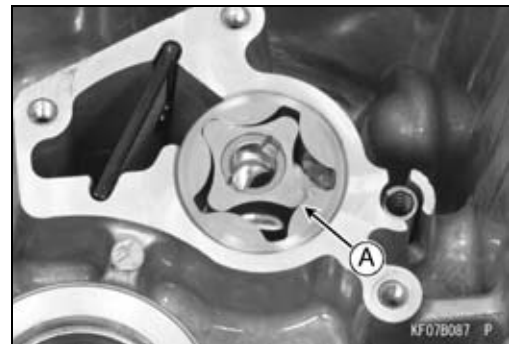

Oil Pump, Relief Valve

- Measure the outside diameter [A] of the pump shaft with a micrometer at several points.
- ★ If the diameter is less than the service limit, replace the pump shaft with a new one.

Pump Shaft Outside Diameter

Service Limit: 10.923 mm (0.43004 in.)

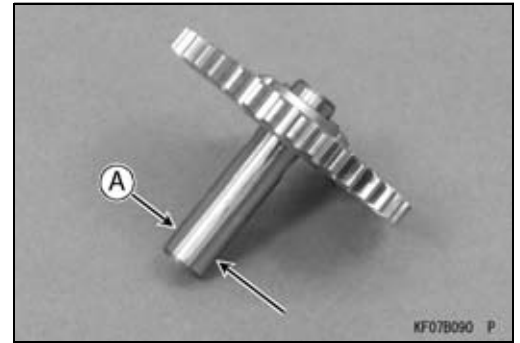

- Measure the inside diameter [A] of the pump shaft bearing in the crankcase with an inside micrometer at several points.
- ★ If the inside diameter is more than the service limit, replace the crankcase with a new one.

Pump Shaft Bearing Inside Diameter

Service Limit: 11.068 mm (0.43575 in.)



- Visually inspect the relief valve spring, steel ball and valve seat in the crankcase.
- ★ If any rough spot is found during above inspection, wash the valve clean with a high-flash point solvent and blow out any foreign particles on the valve with compressed air.

⚠ WARNING

Clean the parts in a well-ventilated area, and take care that there is no spark or flame anywhere near the working areas. Because of the danger of highly flammable liquids, do not use gasoline or low-flash point solvents.

- ★ If cleaning does not solve the problem, replace the relief valve parts with new ones.
- ★ If necessary, put the ball in position and lightly tap the ball with a suitable tool to form a perfect seat.
- Measure the free length [A] of the spring with a vernier caliper.
- ★ If the free length of the spring is less than the service limit, replace the spring with a new one.

Relief Valve Spring Free Length

Service Limit: 20.6 mm (0.811 in.)

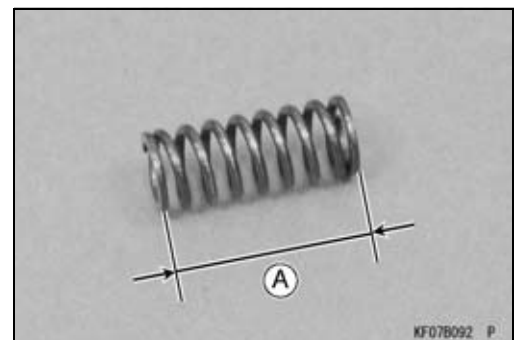

6-12 LUBRICATION SYSTEM

Oil Screen

Oil Screen Removal

- Remove the oil pump parts assembly (see Oil Pump, Relief Valve Removal).
- Remove the oil screen [A].

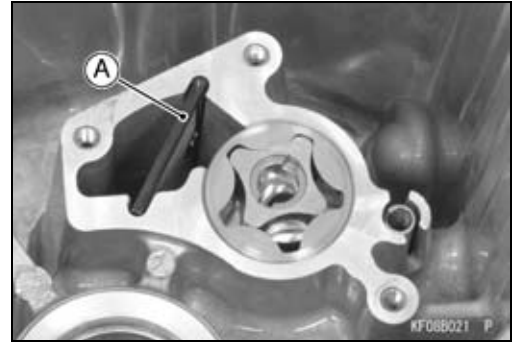

Oil Screen Installation

- Clean the oil screen thoroughly whenever it is removed for any reason (see Cleaning and Inspection).
- Insert the oil screen [A] in position.
- Install the oil pump parts assembly (see Oil Pump, Relief Valve Installation).

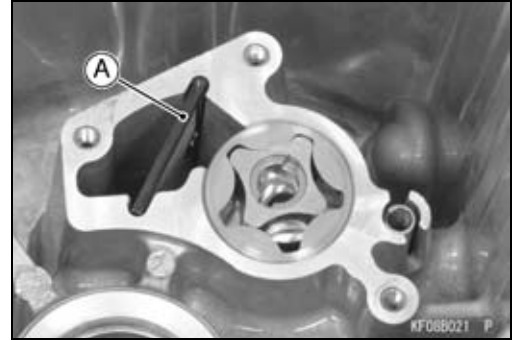

Cleaning and Inspection

- Clean the oil screen [A] with high-flash point solvent and remove any particles on it.

⚠ WARNING

Clean the screen in a well-ventilated area, and take care that there is no spark or flame anywhere near the working area. Because of the danger of highly flammable liquids, do not use gasoline or low-flash point solvents.

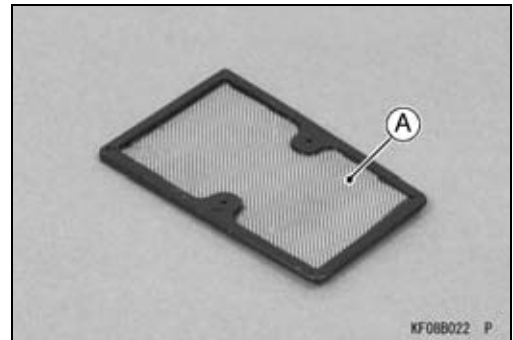

NOTE

- *While cleaning the screen, check for any metal particles that might indicate internal engine damage.*
- Check the screen carefully for any damage: holes and broken wire.
- ★ If the screen is damaged, replace it with a new one.

Camshaft/Crankshaft

Table of Contents

Exploded View	7-2
Specifications	7-4
Special Tools and Sealant	7-5
Crankcase	7-6
Crankcase Cover Removal	7-6
Crankcase Cover Disassembly	7-6
Crankcase Cover Assembly	7-6
Crankcase Cover Installation	7-7
Crankcase Disassembly	7-8
Crankcase Assembly	7-8
Crankcase Inspection	7-9
Crankcase and Crankcase Cover Cleaning	7-9
Breather	7-10
Breather Valve Removal	7-11
Breather Valve Installation	7-11
Breather Valve Inspection	7-11
Breather Pipe Removal	7-12
Breather Pipe Installation	7-12
Camshaft, Tappet	7-13
Camshaft, Tappet Removal	7-13
Camshaft, Tappet Installation	7-13
Camshaft Inspection	7-14
Camshaft Bearing/Journal Wear	7-14
Crankshaft, Connecting Rod	7-15
Connecting Rod Removal	7-15
Connecting Rod Installation	7-15
Crankshaft Removal	7-15
Crankshaft Installation	7-15
Cleaning/Inspection	7-15
Connecting Rod Bend/Twist	7-16
Connecting Rod Big End/Crankpin Width Wear	7-16
Connecting Rod Big End Bearing/Crankpin Wear	7-17
Crankshaft Runout	7-17
Crankshaft Main Journal/Wear	7-18

7-2 CAMSHAFT/CRANKSHAFT

Exploded View

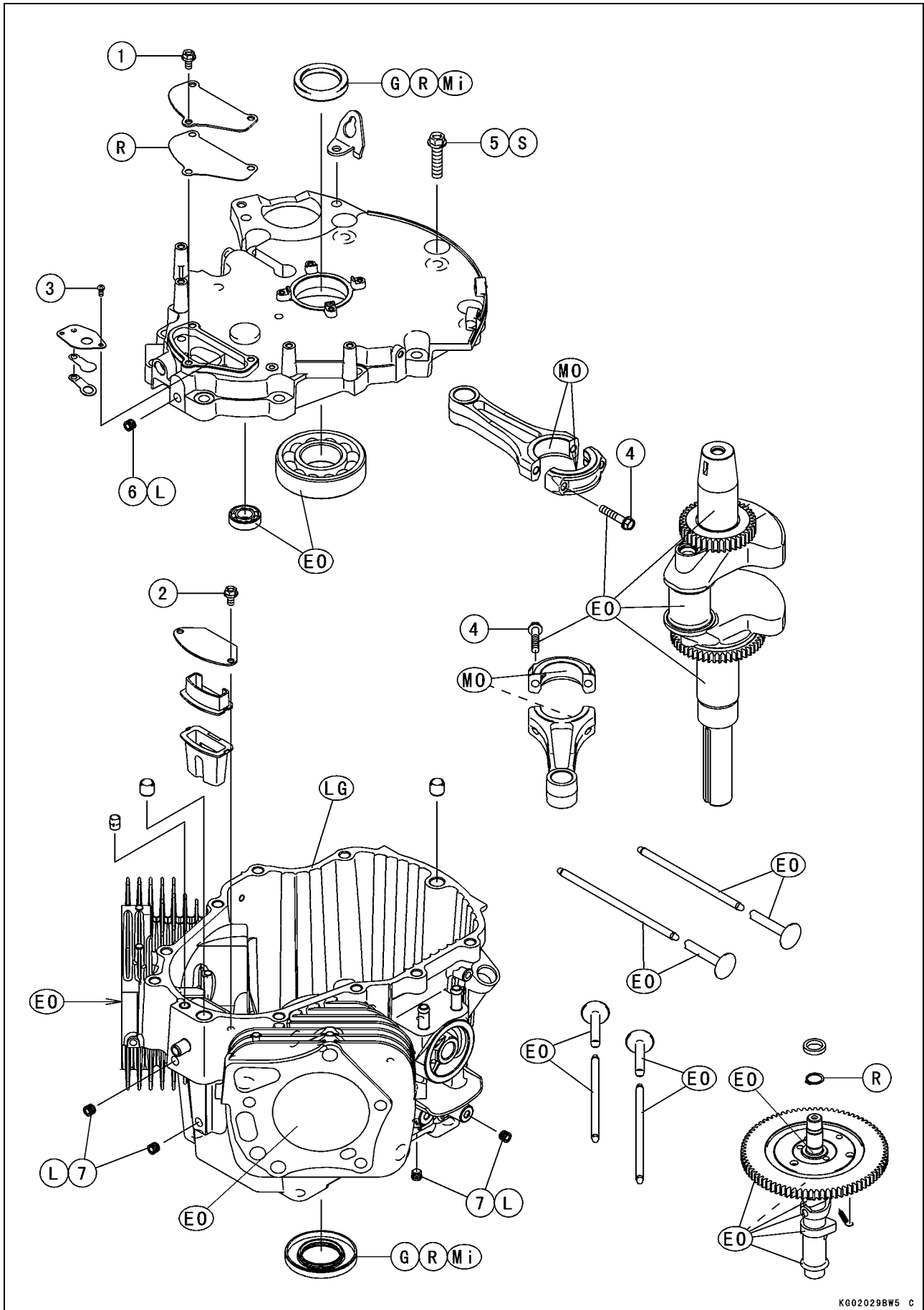

Exploded View

No.	Fastener	Torque			Remarks
		N·m	kgf·m	ft·lb	
1	Breather Chamber Cover Bolts	5.9	0.60	52 in·lb	
2	Breather Pipe Cover Bolts	5.9	0.60	52 in·lb	
3	Breather Valve Mounting Screws	2.0	0.20	18 in·lb	
4	Connecting Rod Big End Cap Bolts	20.6	2.10	15.2	EO
5	Crankcase Cover Bolts	46	4.7	34	S
6	Crankcase Cover Oil Passage Plugs	3.9	0.40	35 in·lb	L
7	Crankcase Oil Passage Plugs	3.9	0.40	35 in·lb	L

EO: Apply engine oil.

G: Apply grease.

L: Apply a non-permanent locking agent.

LG: Apply liquid gasket.

Mi: Apply mineral oil.

MO: Apply molybdenum disulfide oil.

R: Replacement Parts

S: Tighten the fasteners following the specified sequence.

7-4 CAMSHAFT/CRANKSHAFT

Specifications

Item	Service Limit
Camshaft, Tappet Cam Lobe Height: Intake Exhaust Camshaft Journal Diameter PTO Side Flywheel Side Camshaft Bearing Inside Diameter Crankcase	 35.72 mm (1.406 in.) 36.84 mm (1.450 in.) 19.99 mm (0.787 in.) 14.95 mm (0.589 in.) 20.14 mm (0.7929 in.)
Crankshaft, Connecting Rod Connecting Rod Bend Connecting Rod Twist Connecting Rod Big End Width Crankpin Width Connecting Rod Big End Inside Diameter Crankpin Outside Diameter Crankshaft Runout Crankshaft Journal Diameter PTO Side Flywheel Side	TIR 0.15/100 mm (0.006/3.94 in.) TIR 0.15/100 mm (0.006/3.94 in.) 22.70 mm (0.8937 in.) 49.0 mm (1.93 in.) 42.04 mm (1.655 in.) 41.94 mm (1.651 in.) TIR 0.05 mm (0.002 in.) 41.90 mm (1.650 in.) 39.95 mm (1.573 in.)
Crankcase PTO Shaft Bearing Inside Diameter	42.15 mm (1.659 in.)

Special Tools and Sealant

**Oil Seal & Bearing Remover:
57001-1058**

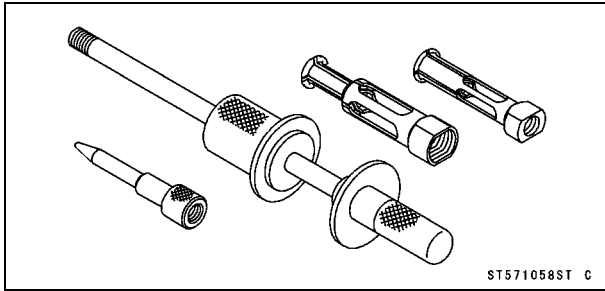

**Liquid Gasket, TB1217H:
92104-7001**

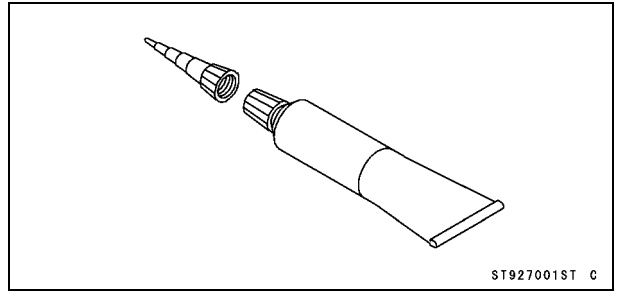

**Bearing Driver Set:
57001-1129**

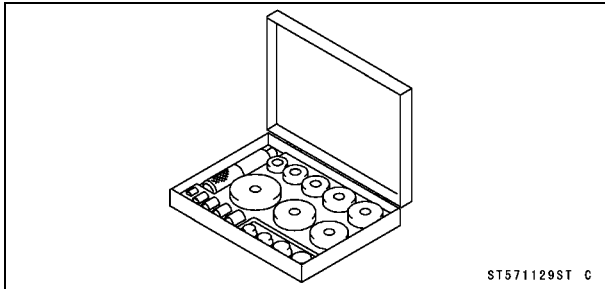

7-6 CAMSHAFT/CRANKSHAFT

Crankcase

Crankcase Cover Removal

- Set the engine on a clean surface while parts are being removed.
- Drain the engine oil (see Engine Oil Change in the Periodic Maintenance chapter).
- Remove:
 - Throttle Body Assy (see Throttle Body Assy Removal in the Fuel System (DFI) chapter)
 - Engine Shroud (see Engine Shroud Removal in the Cooling System chapter)
 - Intake Manifold (see Intake Manifold Removal in the Fuel System (DFI) chapter)
 - Ignition Coils (see Ignition Coil Removal in the Electrical System chapter)
 - Flywheel and Stator Coil (see Flywheel and Stator Coil Removal in the Electrical System chapter)
 - Starter Motor (see Starter Motor Removal in the Starter System chapter)
 - Bolt [A]
 - Oil Filler [B]
- Unscrew the mounting bolts in the order shown [1 to 11] and remove the crankcase cover from the crankcase.
- There are two dowel pins on the crankcase mating surface. Using a wooden or plastic mallet, gently tap crankcase to loosen the crankcase cover.

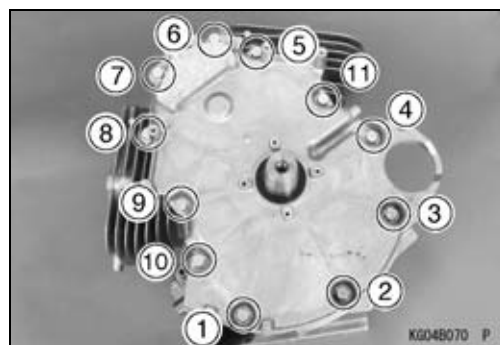
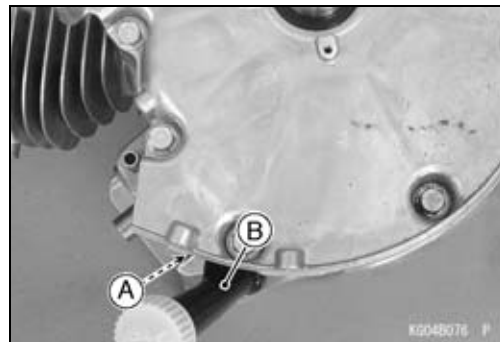

Crankcase Cover Disassembly

- Remove the crankcase cover (see Crankcase Cover Removal).
- Pry the crankshaft oil seal [A] with the suitable tool, and remove it.
- Remove the ball bearing.

Special Tool - Oil Seal & Bearing Remover: 57001-1058

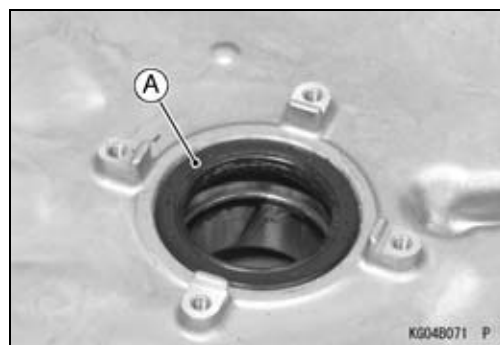

Crankcase Cover Assembly

- Chip the old gasket from the mating surfaces of the crankcase and cover.
- Using compressed air, blow out the oil passage in the crankcase cover.
- With a high-flash point solvent, clean off the mating surfaces of the crankcase and cover, and wipe them dry.

⚠ WARNING

Clean the crankcase and cover in a well-ventilated area, and take care that there are no sparks or flame anywhere near the working area; this includes any appliance with a pilot light. Do not use gasoline or a low-flash point solvent to clean parts. A fire or explosion could result.

Crankcase

- Be sure to replace the ball bearing with a new one if removed.
- Apply engine oil to the ball bearing [A].
- Press the ball bearing until bottom surface [B] of the crankcase cover.

Special Tool - Bearing Driver Set: 57001-1129

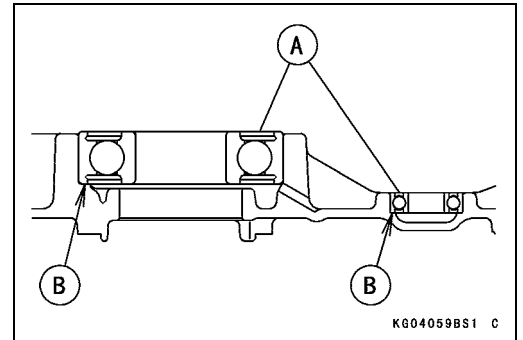

- Be sure to replace any oil seal with a new one if removed.
- Apply mineral oil to the crankshaft oil seal outside.
- Install the oil seal so that the marks [A] face out.
- Thoroughly pack high-temperature grease to 60% volume into the space [B] between the seal lip [C] and dust lip [D]. Press in the new oil seal using a press or suitable tools until it is flush with flange surface [E] or maximum 1 mm (0.04 in.) [F] lower than the flange surface. Do not damage the seal lip.

Flywheel Side [G]

- Install the removed parts (see appropriate chapters).

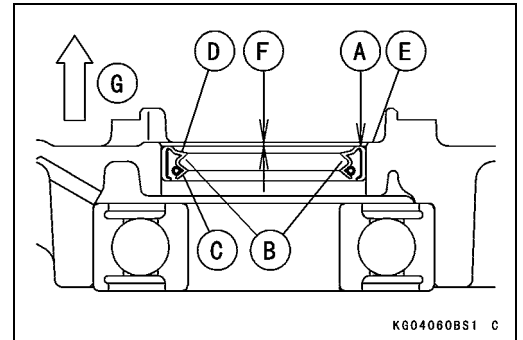

Crankcase Cover Installation

- Apply liquid gasket [A] to the mating surface of the crankcase cover.

Sealant - Liquid Gasket, TB1217H: 92104-7001

NOTE

- Make the application finish within 5 minutes when the liquid gasket to the mating surface of the crankcase cover is applied.
- Moreover fit the case and tighten the cover bolts just after finishing the application of the liquid gasket.

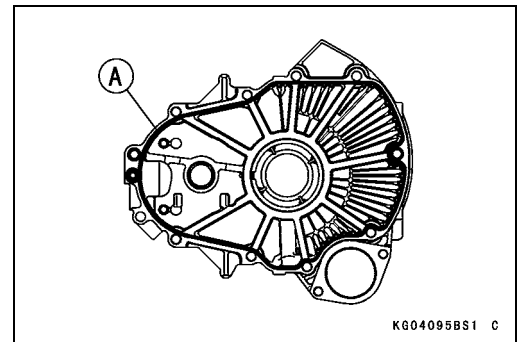

- Check to see that the dowel pins [A], and plastic pipe [B] place on the crankcase.

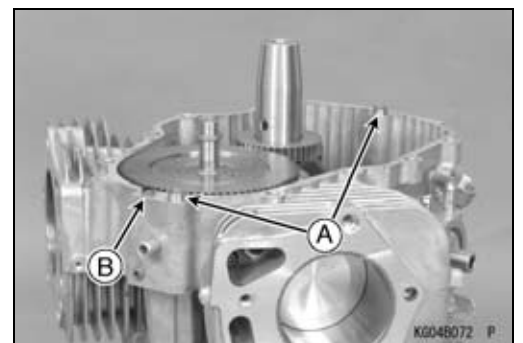

7-8 CAMSHAFT/CRANKSHAFT

Crankcase

- Install the crankcase cover and tighten the crankcase cover bolts following the tightening sequence as shown in the figure.

Torque - Crankcase Cover Bolts: 46 N·m (4.7 kgf·m, 34 ft·lb)

- Do not turn one screw down completely before the others, as it may cause the crankcase cover to warp.

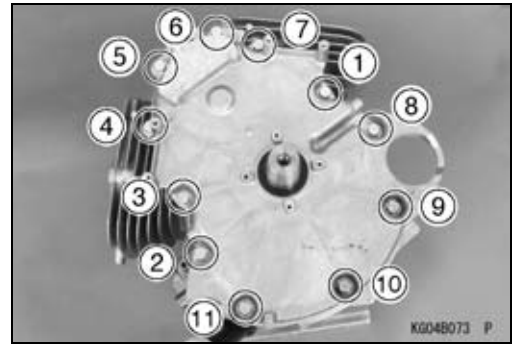

- Install the oil filler.
- Tighten:
Torque - Oil Filler Mounting Bolt: 5.9 N·m (0.60 kgf·m, 34 in·lb)
- Install the removed parts (see appropriate chapters).

Crankcase Disassembly

- Remove:
Crankcase Cover (see Crankcase Cover Removal)
Camshaft and Tappets (see Camshaft, Tappet Removal)
Breather Pipe (see Breathe Pipe Removal)
Crankshaft (see Crankshaft Removal)
Oil Pump, Relief Valve (see Oil Pump, Relief Valve Removal in the Lubrication System chapter)
Oil Screen (see Oil Screen Removal in the Lubrication System chapter)
- Pry the crankshaft oil seal with the suitable tool, and remove it.

Crankcase Assembly

- Remove the old gasket from the mating surfaces of the crankcase and cover.
- Using compressed air, blow out the oil passage in the crankcase.
- With a high-flash point solvent, clean off the mating surfaces of the crankcase and the cover, and wipe them dry.

⚠ WARNING

Clean the crankcase and cover in a well-ventilated area, and take care that there are no sparks or flame anywhere near the working area; this includes any appliance with a pilot light. Do not use gasoline or a low-flash point solvent to clean parts. A fire or explosion could result.

- Be sure to replace the oil seal with a new one if removed.
- Apply mineral oil to the crankshaft oil seal outside.
- Install the oil seal so that the marks [A] face out.
- Thoroughly pack high-temperature grease to 60% volume into the space [B] between the seal lip [C] and dust lip [D]. Press in the new oil seal using a press or suitable tools until it is flush with flange surface [E] or maximum 1 mm (0.04 in.) [F] lower than the flange surface. Do not damage the seal lip.
PTO Side [G]

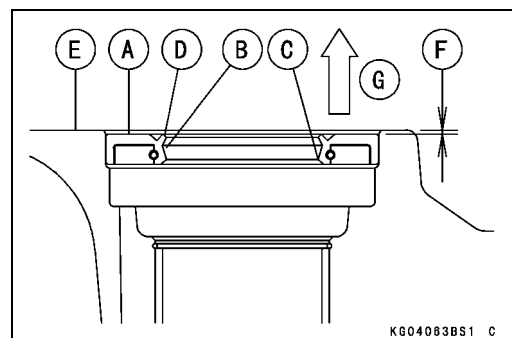

Crankcase

Crankcase Inspection

- Measure the inside diameter [A] of the crankshaft insert on the crankcase at several points. Replace the crankcase if the inside diameter is more than the service limit.

PTO Shaft Bearing Inside Diameter

Service Limit: 42.15 mm (1.659 in.)

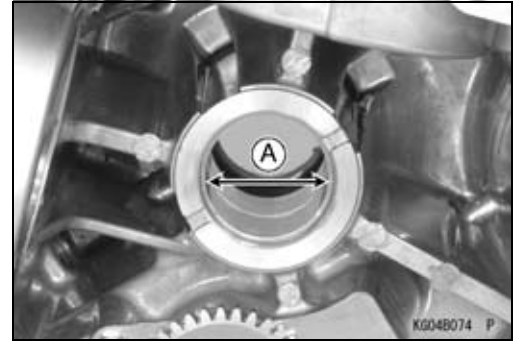

Crankcase and Crankcase Cover Cleaning

- Remove:
 - Oil Pump and Relief Valve (see Oil Pump, Relief Valve Removal in the Lubrication System chapter)
 - Camshaft and Tappets (see Camshaft, Tappet Removal)
 - Crankshaft (see Crankshaft Removal)
 - Breather Pipes and Cover (see Breather Pipe Removal)
- Clean up the crankcase and cover with a high-flash point solvent, and blow out any foreign particles that may be in the pockets inside of the crankcase with compressed air.

⚠ WARNING

Clean the crankcase and cover in a well-ventilated area, and take care that there is no spark or flame anywhere near the working area. Because of the danger of highly flammable liquids, do not use gasoline or low-flash point solvents.

7-10 CAMSHAFT/CRANKSHAFT

Breather

The function of the breather is to create a negative pressure in the crankcase which prevents oil from being forced out of the engine through the piston rings, oil seals or gaskets. A sealed-type crankcase emission control system is used to prevent blow-by gases from emitting in the air. The blow-by gases are led to the breather chamber through the crankcase and camshaft. Then, it is drawn into the clean side of the air cleaner through the cylinder head and hose and mixed with the clean air flow, and subsequently comes into the combustion chamber through the throttle body assy and intake manifold.

Oil is primarily separated from the gases while passing through the inside of the rocker chamber from the crankcase, and secondly separated from the gases in the breather chamber, and then returned back to the crankcase cover.

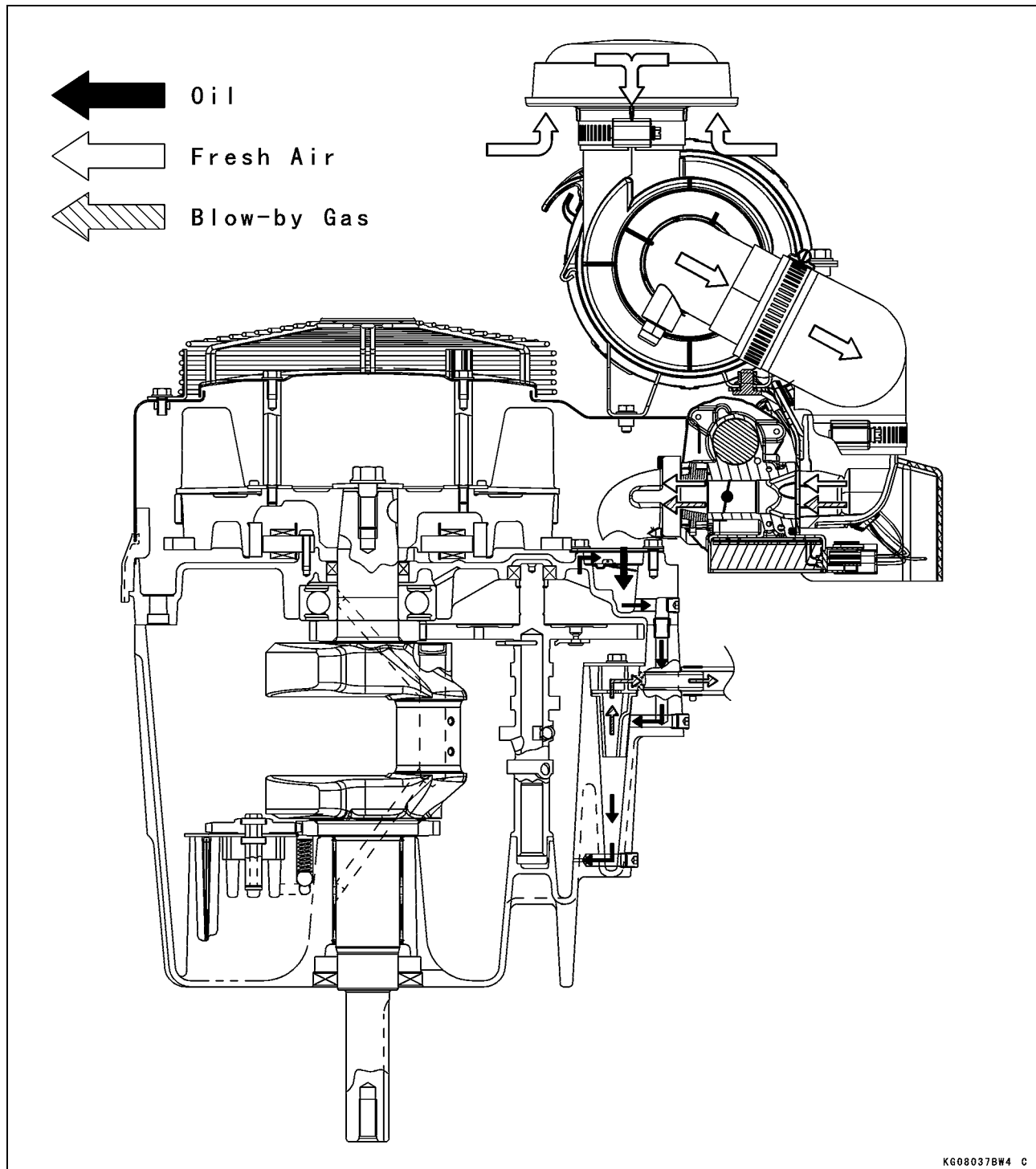

Breather

Breather Valve Removal

- Remove:
 - Intake Manifold (see Intake Manifold Removal in the Fuel System (DFI) chapter)
 - Bolts [A]
 - Breather Chamber Cover [B] and Gasket

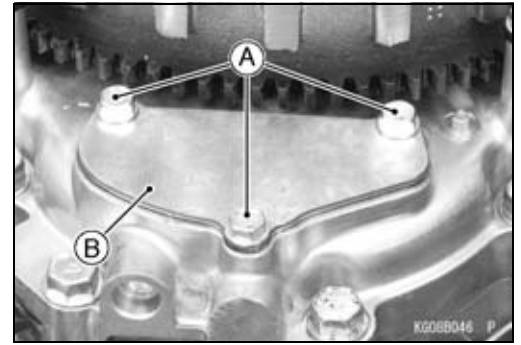

- Remove:
 - Screws [A]
 - Breather Valve [B]

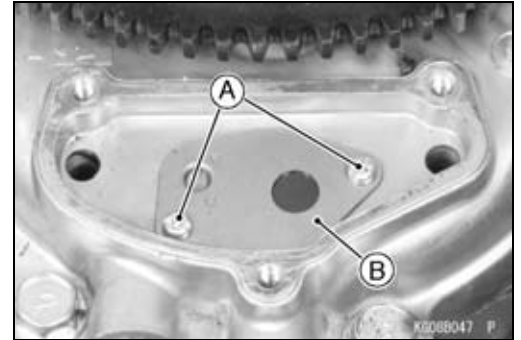

Breather Valve Installation

- Install the breather valve.
- Tighten:
 - Torque - Breather Valve Mounting Screws: 2.0 N·m (0.20 kgf·m, 18 in·lb)**
- Be sure the drain holes [A] on the breather chamber does not accumulate with slugs.
- Replace the breather chamber cover gasket with a new one.
- Tighten:
 - Torque - Breather Chamber Cover Bolts: 5.9 N·m (0.60 kgf·m, 52 in·lb)**
- Install the removed parts (see appropriate chapters).

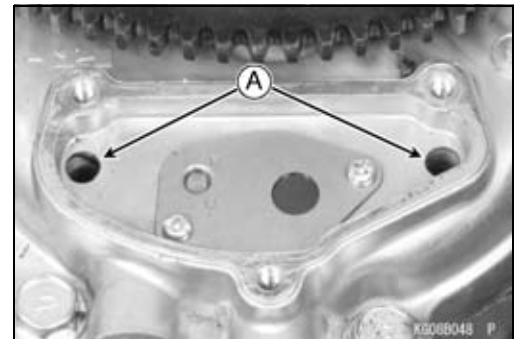

Breather Valve Inspection

- Inspect the reed valve [A] for breakage, crack or distortion, replace it with a new one if necessary.
- Inspect the plate [B] for damage or rough contact surface, replace it with a new one if necessary.
- Inspect the valve seating surface [C]. The surface should be no nicks or burrs.

NOTE

- *The mounting screw is a self-tapping one. Be aware that misthreading or overtightening screw will strip the female threads and break the hole.*

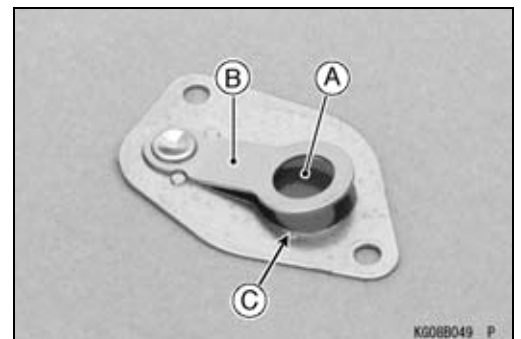

7-12 CAMSHAFT/CRANKSHAFT

Breather

Breather Pipe Removal

- Remove:
 - Camshaft (see Camshaft, Tappet Removal)
 - Bolts [A]
 - Breather Pipe Cover [B]

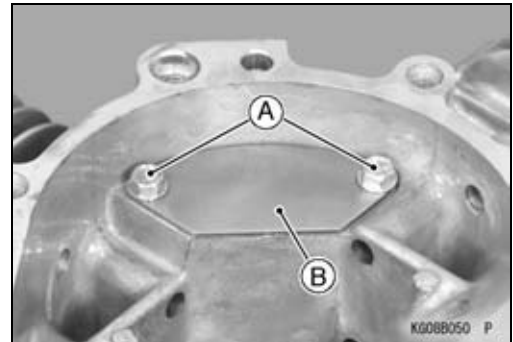

- Remove the upper breather pipe [A].

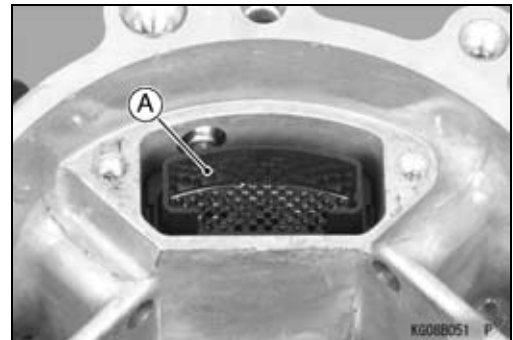

- Remove the lower breather pipe [A].

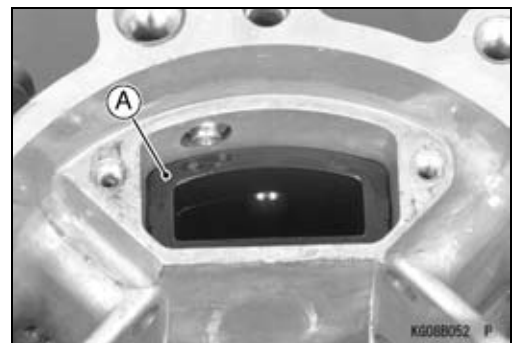

Breather Pipe Installation

- Install the lower and upper breather pipes.
- Install the breather pipe cover [A].
- Tighten:
 - Torque - Breather Pipe Cover Bolts [B]: 5.9 N·m (0.60 kgf·m, 52 in·lb)

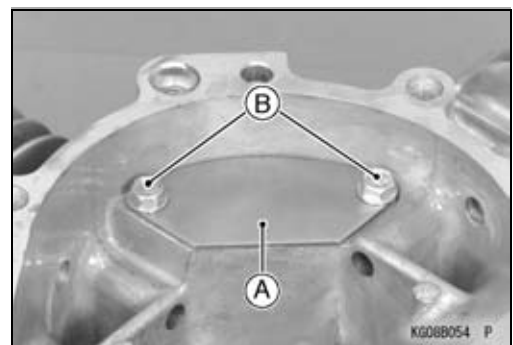

Camshaft, Tappet

Camshaft, Tappet Removal

- Set the engine on a clean surface while parts are removed.
- Drain the engine oil (see Engine Oil Change in the Periodic Maintenance chapter).
- Remove:
 - Crankcase Cover (see Crankcase Cover Removal)
 - Rocker Covers (see Cylinder Head Assembly Removal in the Engine Top End chapter)
 - Push Rods (see Push Rod Removal in the Engine Top End chapter)
- Turn the crankcase upside down so that the tappets will fall away from the cam lobes.
- Remove the spacer [A].
- Pull the camshaft [B] out of the crankcase.

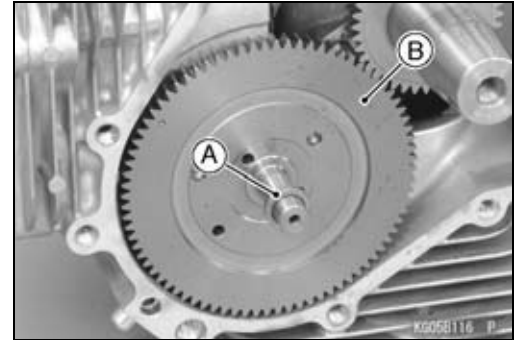

- Remove the tappets [A] and mark them so they can be installed in their original positions during assembly.

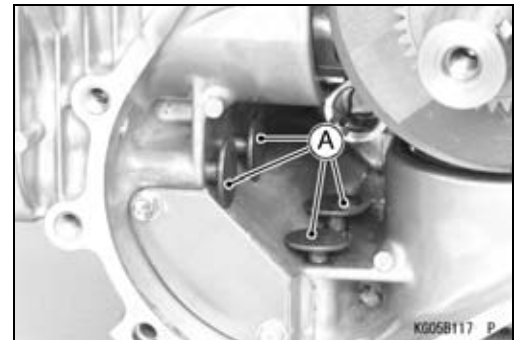

Camshaft, Tappet Installation

- Apply engine oil to the followings.
 - Tappet Journal
 - Camshaft Journal
 - Cam Lobe Surface
 - Camshaft Gear
 - Camshaft Bearing
- Align the punch marks [A] on the crankshaft gear and camshaft gear.
- Install the spacer [A] on the camshaft.
- Install the removed parts (see appropriate chapters).



7-14 CAMSHAFT/CRANKSHAFT

Camshaft, Tappet

Camshaft Inspection

- Check the camshaft gear [A] for pitting, fatigue cracks, burrs or any evidence of improper tooth contact.
- ★ Replace the camshaft with a new one if necessary.
- Check the top of the cam lobes [B] for wear, burrs or uneven contact.
- ★ Replace the camshaft with a new one if necessary.

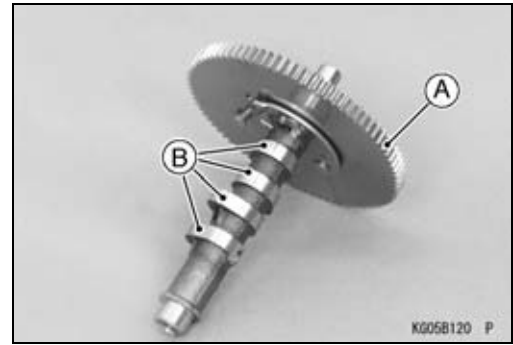

Camshaft Bearing/Journal Wear

- Measure the height [A] of each cam lobe.
- ★ If the cam height is less than the service limit for either lobe, replace the camshaft with a new one.

Cam Lobe Height

Service Limit:

Intake	35.72 mm (1.406 in.)
Exhaust	36.84 mm (1.450 in.)

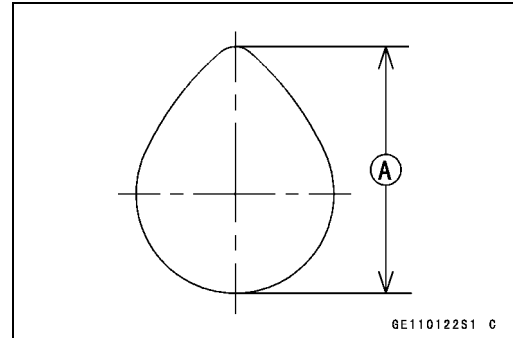

- Measure both camshaft journal diameter at several points around the journal circumference.
- ★ If the journal diameter is less than the service limit, replace the camshaft with a new one.

Camshaft Journal Diameter

Service Limit:

PTO Side [A]	19.99 mm (0.787 in.)
Flywheel Side [B]	14.95 mm (0.589 in.)

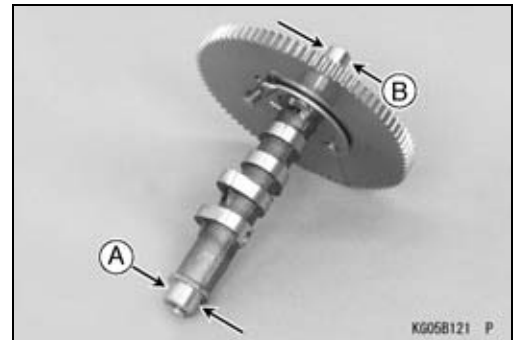

- Measure the inside diameter [A] of the camshaft insert on the crankcase cover at several points.
- ★ If the inside diameter is more than the service limit, replace the crankcase with a new one.

Camshaft Bearing Inside Diameter (Crankcase)

Service Limit: 20.14 mm (0.7929 in.)



Crankshaft, Connecting Rod

Connecting Rod Removal

- Remove the piston (see Piston Removal in the Engine Top End chapter).

Connecting Rod Installation

- Install the piston (see Piston Installation in the Engine Top End chapter).

Crankshaft Removal

- Drain the engine oil (see Engine Oil Change in the Periodic Maintenance chapter).
- Remove:
 - Camshaft (see Camshaft, Tappet Removal)
 - Connecting Rod and Piston Assembly (see Piston Removal in the Engine Top End chapter)
- Pull the crankshaft [A] out of the crankcase. Tap gently with a wooden or plastic mallet if necessary to loosen the crankshaft.

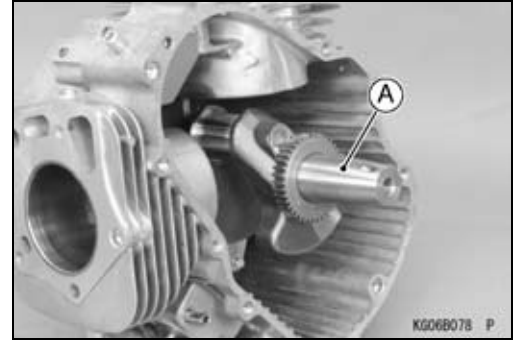

Crankshaft Installation

- Clean up the crankshaft and crankcase thoroughly, especially at the bearing contact surfaces.
- Pack some amount of high-temperature grease into the oil seals on the crankcase.
- Apply engine oil to the crankshaft journal and ball bearing.
- Apply molybdenum disulfide oil solution to the crankpin.
 - The molybdenum disulfide oil solution is a mixture of engine oil and molybdenum disulfide grease with a weight ratio (10:1).
- Carefully insert the crankshaft end into the main bearing and the oil seal in the crankcase.

Cleaning/Inspection

- After removing, clean the crankshaft and the connecting rods with a high-flash point solvent and dry them with compressed air.
- Inspect the teeth of the crankshaft gear for pitting, fatigue cracks, burrs and any evidence of improper tooth contact.
 - ★ Replace the gear with a new one if necessary.
- Inspect the crankshaft and connecting rods especially at the bearing surfaces for wear, scratches, any evidence of improper contact or other damages.
 - ★ Replace them with new ones if necessary.

7-16 CAMSHAFT/CRANKSHAFT

Crankshaft, Connecting Rod

Connecting Rod Bend/Twist

- Measure the connecting rod bend.
- Select an arbor [A] of the same diameter as the connecting rod big end, and insert the arbor through the connecting rod big end.
- Select an arbor of the same diameter as the piston pin and at least 100 mm (3.94 in.) long, and insert the arbor through the connecting rod small end.
- On a surface plate, set the big-end arbor on V blocks.
- With the connecting rod held vertically, use a height gauge to measure the height difference of the small end arbor on the surface plate. Using a dial gauge, measure the height at two different positions and the distance of the two positions is 100 mm (3.94 in.) [B]. Then determine the connecting rod bent from the measured height differences [C].
- ★ If connecting rod bend exceeds the service limit, replace the connecting rod with a new one.

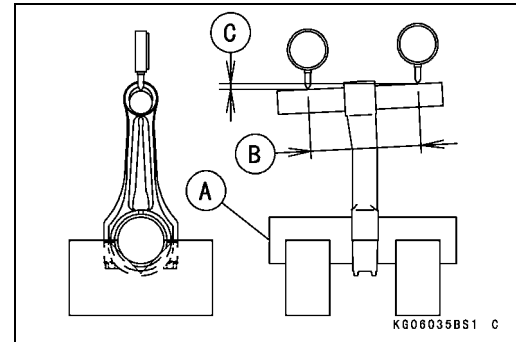

Connecting Rod Bend

Service Limit: TIR 0.15/100 mm (0.006/3.94 in.)

- Measure the connecting rod twist.
- With the big-end arbor still on the V blocks, hold the connection rod horizontally and measure the amount that the small end arbor difference. Using a dial gauge, measure the height at two different positions and the distance of the two positions is 100 mm (3.94 in.) [A]. Then determine the connecting rod twist from the measured height differences [B].
- ★ If connection rod twist exceeds the service limit, replace the connecting rod with a new one.

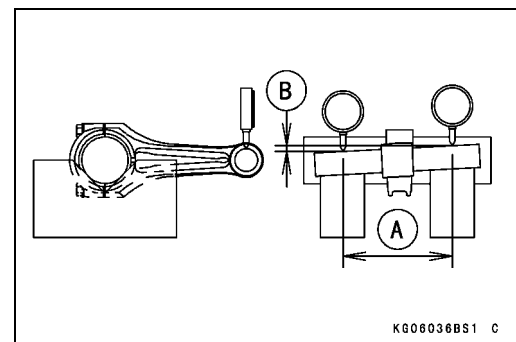

Connecting Rod Twist

Service Limit: TIR 0.15/100 mm (0.006/3.94 in.)

Connecting Rod Big End/Crankpin Width Wear

- Measure the connecting rod big end width [A] with a micrometer or a dial caliper.
- ★ If the measurement is less than the service limit, replace the connecting rod with a new one.

Connecting Rod Big End Width

Service Limit: 22.070 mm (0.8937 in.)

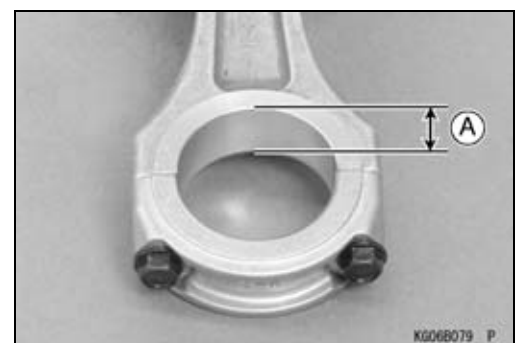

Crankshaft, Connecting Rod

- Measure the crankpin width [A] with a dial caliper.
- ★ If the crankpin width is more than the service limit, replace the crankshaft with a new one.

Crankpin Width

Service Limit: 49.0 mm (1.93 in.)

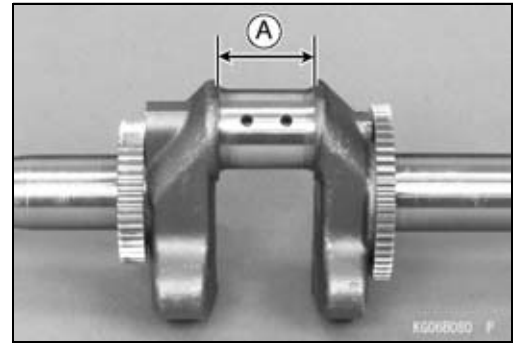

Connecting Rod Big End Bearing/Crankpin Wear

- Apply a light film of engine oil on the threads of the cap bolts.
- Install the cap bolts and tighten the bolts to the specified torque (see Piston Installation in Engine Top End chapter).
- Measure the inside diameter [A] of big end at several points with a telescoping gauge or inside micrometer.
- ★ If the inside diameter is more than the service limit, replace the connecting rod with a new one.

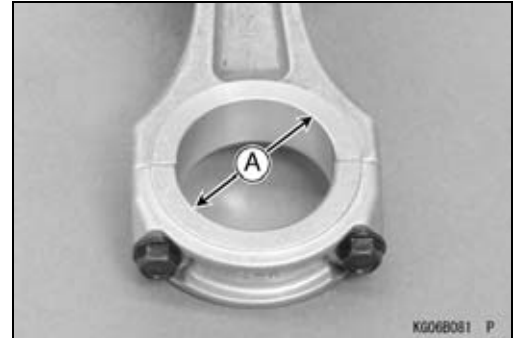

Connecting Rod Big End Inside Diameter

Service Limit: 42.04 mm (1.655 in.)

- Measure the crankpin outside diameter [A].
- Use a micrometer to measure several points around the crankpin circumference.
- ★ If the crankpin diameter is less than the service limit, replace the crankshaft with a new one.

Crankpin Outside Diameter

Service Limit: 41.94 mm (1.651 in.)



Crankshaft Runout

- Measure the crankshaft runout.
- Set the crankshaft in a flywheel alignment jig [A] or on V blocks gauge.
- Set a dial gauge [B] against both bearing journals.
- Turn the crankshaft slowly to measure the runout. The difference between the highest and lowest dial gauge readings (TIR) is the amount of runout.
- ★ If the measurement exceeds the service limit, replace the crankshaft with a new one.

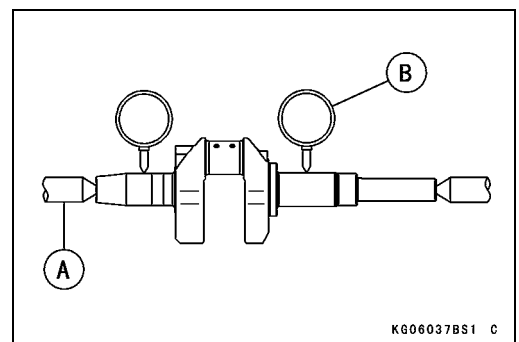

Crankshaft Runout

Service Limit: TIR 0.05 mm (0.002 in.)

7-18 CAMSHAFT/CRANKSHAFT

Crankshaft, Connecting Rod

Crankshaft Main Journal/Wear

- Measure both main journals at several points around the journal circumference.
- ★ If the journal diameter is less than the service limit, replace the crankshaft with a new one.

Crankshaft Journal Diameter

Service Limit:

PTO Side [A] 41.90 mm (1.650 in.)

Flywheel Side [B] 39.95 mm (1.573 in.)

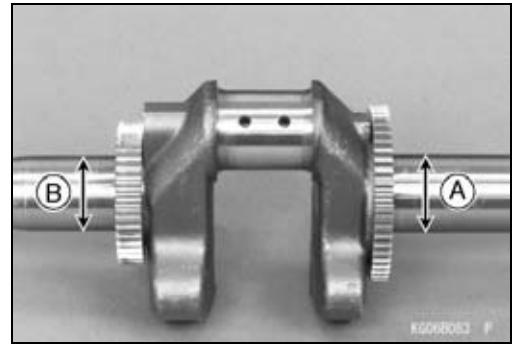

Starter System

Table of Contents

Exploded View	8-2
Specifications	8-4
Electric Starter System	8-5
Starter Motor Removal	8-5
Starter Motor Installation	8-5
Starter Solenoid and Circuit Test	8-5
Starter Motor Test	8-6
Starter Motor Disassembly	8-7
Starter Motor Assembly	8-8
Starter Motor Brush Inspection	8-10
Brush Spring Inspection	8-10
Armature Inspection	8-11
Yoke Assembly Inspection	8-12
Pinion Clutch Inspection	8-13

8-2 STARTER SYSTEM

Exploded View

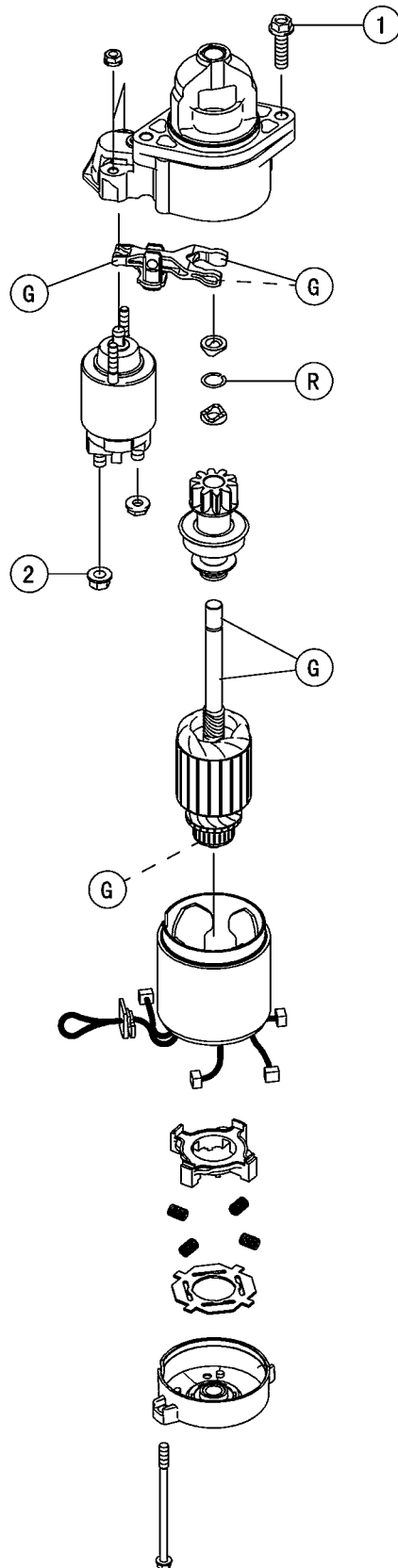

STARTER SYSTEM 8-3

Exploded View

No.	Fastener	Torque			Remarks
		N-m	kgf-m	ft-lb	
1	Starter Motor Mounting Bolts	19.6	2.0	14	
2	Starter Motor Terminal Nut	8.8	0.90	78 in-lb	

G: Apply grease.

R: Replacement Parts

8-4 STARTER SYSTEM

Specifications

Item	Standard	Service Limit
Electric Starter System		
Starter Motor:		
Carbon Brush Length	10.0 mm (0.39 in.)	6.0 mm (0.24 in.)
Commutator Groove Depth	0.6 mm (0.02 in.)	0.2 mm (0.008 in.)
Commutator Diameter	28.0 mm (1.10 in.)	27.0 mm (1.06 in.)
Commutator Runout	— — —	0.4 mm (0.016 in.)

Electric Starter System

Starter Motor Removal

- Disconnect the wire.
- Remove the mounting bolts [A] and pull the starter motor [B] from the engine with the switch lead attached.

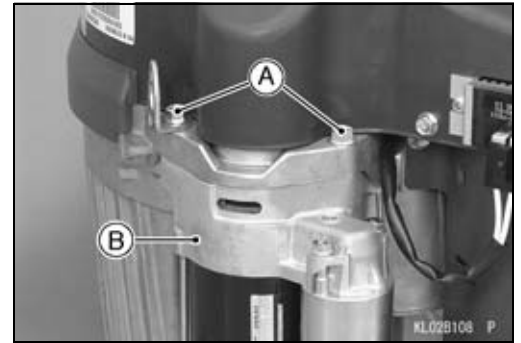

Starter Motor Installation

- Clean the starter motor and engine mounting flanges to ensure good electrical contact and tighten the mounting bolts.
- Install the hook [A] so that the stopper [B] of the hook contacts the crankcase.

Torque - Starter Motor Mounting Bolts: 19.6 N·m (2.00 kgf·m, 14.4 ft·lb)

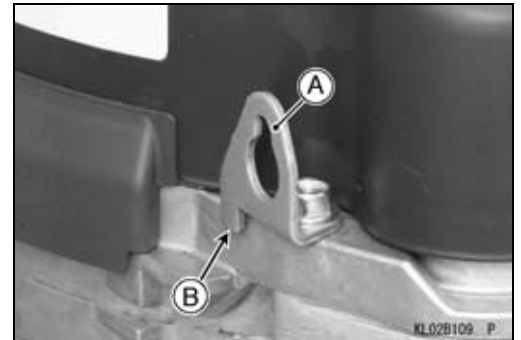

Starter Solenoid and Circuit Test

NOTE

○ Before this test, be sure the battery is fully charged.

- Loosen the terminal nut.
- Disconnect the starter motor lead [A] from the solenoid terminal as shown and keep the lead away from the solenoid terminal.
- Measure the continuity of the solenoid when activated.
- Set the hand tester selector switch to the $R \times 1 \Omega$ position and connect the leads across the large terminals [A] as shown in the figure.
- Turn the engine switch to the START (II) position and read the tester.
- ★ If the solenoid does not click or if the tester reads more than 0Ω the solenoid is faulty. Replace it.
- ★ If the solenoid makes a single clicking sound, the tester reads 0Ω and the rest of the starter circuit is good.
- ★ If solenoid clicks once but the tester does not read 0Ω , the solenoid is faulty. Replace it.
- ★ If the solenoid does not click at all, proceed with the following.

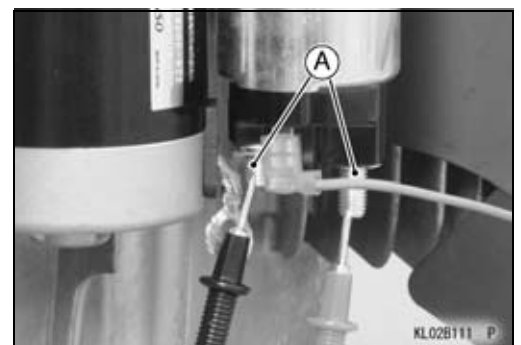

8-6 STARTER SYSTEM

Electric Starter System

- Disconnect the switch lead [A].

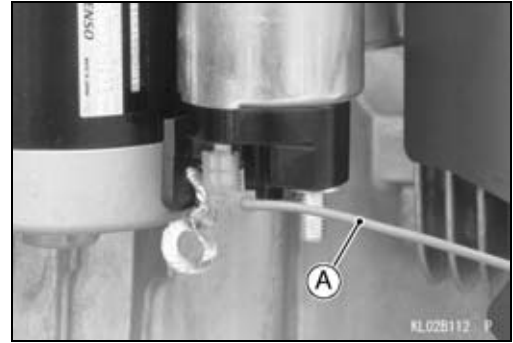

- Set the hand tester to the $R \times 1 \Omega$ position and connect the leads as shown in the figure.
 - Switch Terminal [A]
 - To Ground [B]
- ★ If the tester does not read close to 0Ω , the solenoid is faulty. Replace it.
- ★ If the tester reads close to 0Ω , the solenoid may be good.

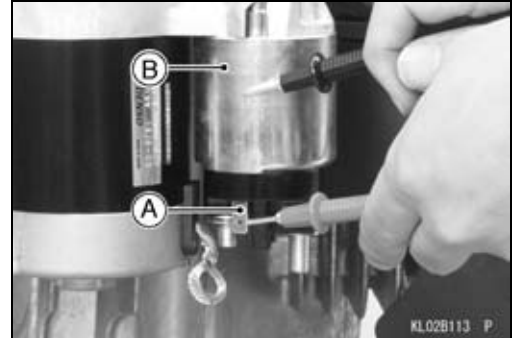

- Check the voltage to the solenoid from the engine switch.
- Set the hand tester selector switch to the 25 V DC position and connect it as shown in the figure.
 - Switch Lead Connector [A]
 - To Ground [B]
- Turn the engine switch to the START (II) position and read the tester.
- ★ If the tester reads battery voltage, the circuit is good.
- ★ If the tester reads much less than battery voltage or no voltage at all, either the wiring or the engine switch is bad. Check the engine switch or the wiring for damaged or broken wires and replace as required.

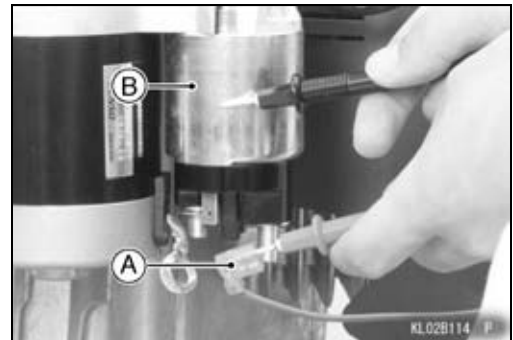

Starter Motor Test

NOTE

○ Always inspect the Starter Solenoid and Circuit Test section before starting following procedures.

- Remove the starter motor (see Starter Motor Removal).
- Hold the starter motor with a vice.

CAUTION

Be careful not to deform the starter motor body when holding it with a vice.

- Connect the first jumper cable to the battery (+) terminal and the other end of the cable to the starter motor terminal on the solenoid as shown in the figure.
- Connect the second jumper cable to the battery (-) terminal.
- Touch the switch intermittently for one second intervals.
- The pinion should rotate freely.
- ★ If the pinion does not rotate freely, replace the starter motor.

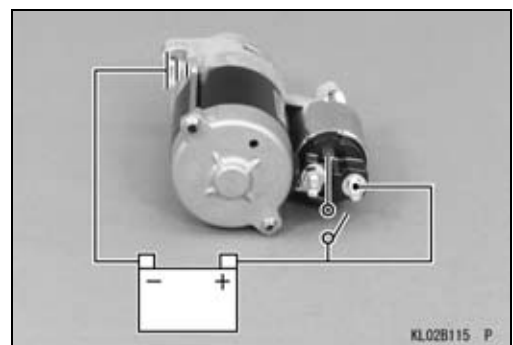

Electric Starter System

Starter Motor Disassembly

- Loosen the terminal nut [A].
- Remove the lead [B] from the starter motor to the solenoid.

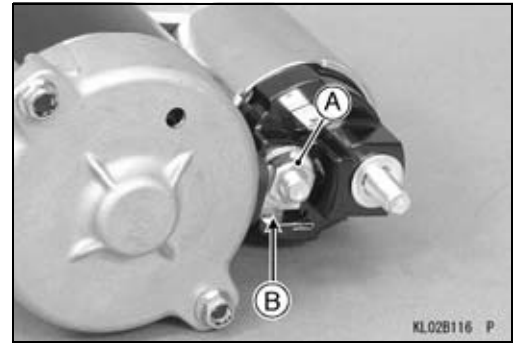

- Unscrew the mounting nuts [A] and remove the solenoid assembly [B].

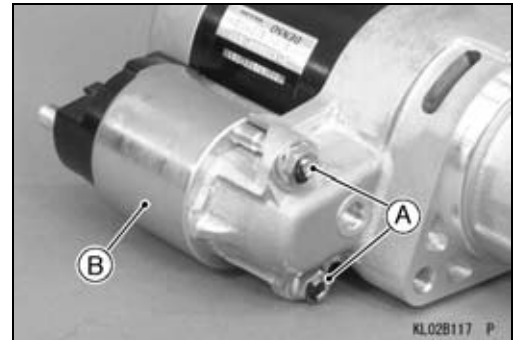

- Remove the through bolts [A] and end cover [B].
- Slide the (-) lead grommet [C] to outside.

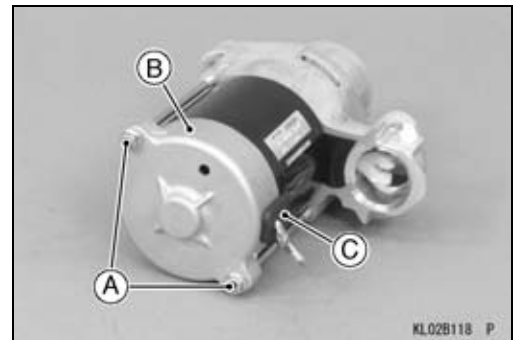

- Remove the insulator [A].

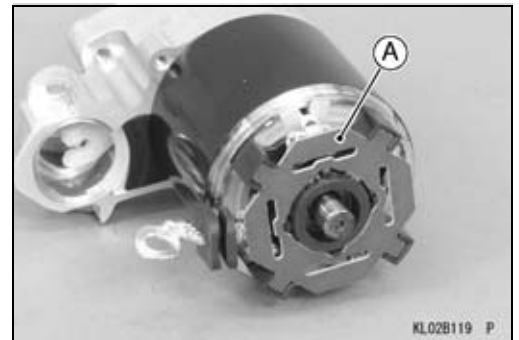

- Remove the springs [A].
- Free the brushes [B] from the brush holder [C].

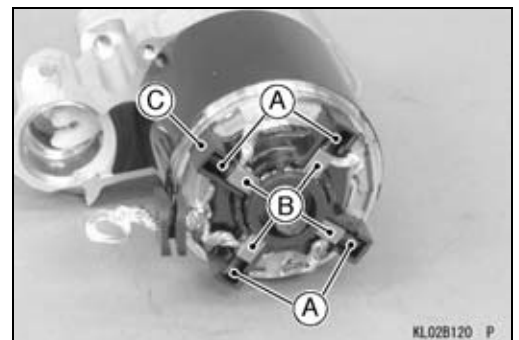

8-8 STARTER SYSTEM

Electric Starter System

- Remove:
Brush Holder [A]
Yoke [B]

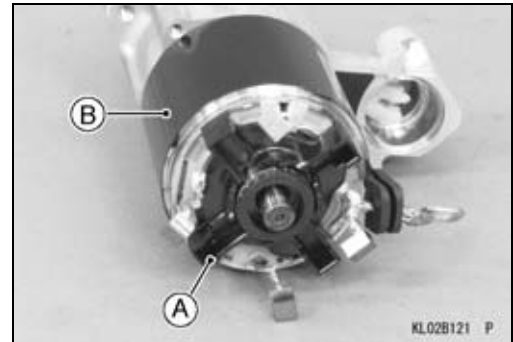

- Remove the armature assembly [A] with the pinion gear fork [B].

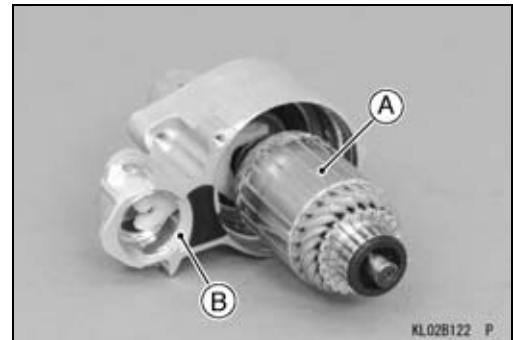

- Remove the front stopper [A].
- Push the rear stopper [B] downward and remove the snap ring [C].
- Pull the rear stopper and pinion clutch [D] from the armature shaft.

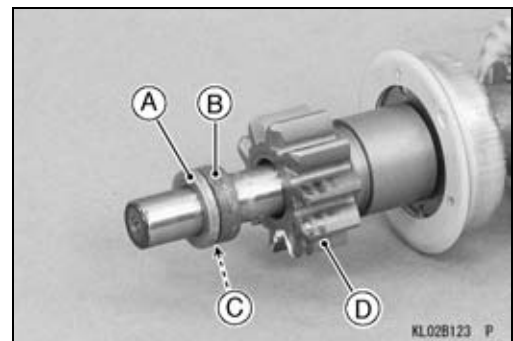

Starter Motor Assembly

- Apply a small amount of grease to the armature shaft [A] as shown in the figure.
- Do not reuse the snap ring [B]. Replace it with a new one.

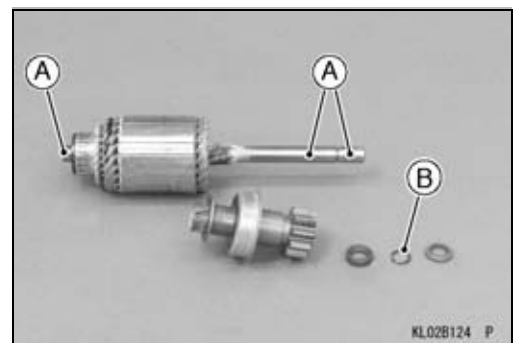

- Inspect the boots [A], grommet [B] and rubber insert [C] for visible damage.
- ★ If it is damaged, replace the related parts.

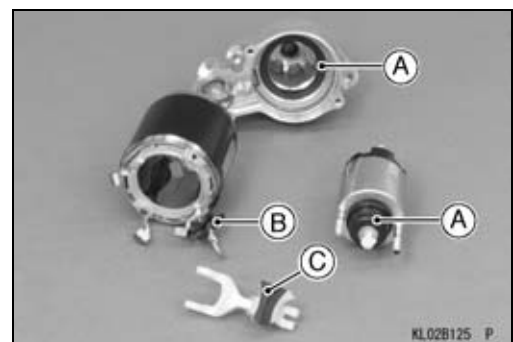

Electric Starter System

- Install the pinion clutch [A].
- Install the rear stopper [B] so that the hollow side face the outside.
- Install the snap ring [C] to the groove of the shaft.
- Slide the rear stopper until the stopping with the snap ring.
- Install the front stopper [D] so that the smaller diameter face the inside.
- Apply grease to the pinion gear fork fingers.
- Assemble the pinion gear fork [E] as shown in the figure.

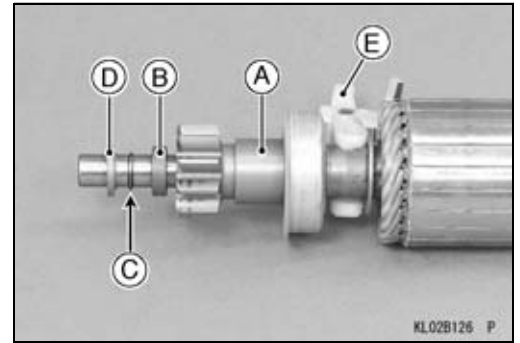

- Install the armature assembly [A] to the pinion gear cover [B].

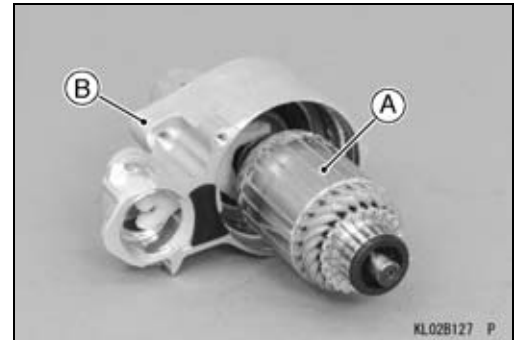

- Install the yoke so that the slit [A] fit the projection [B] of the pinion gear fork.

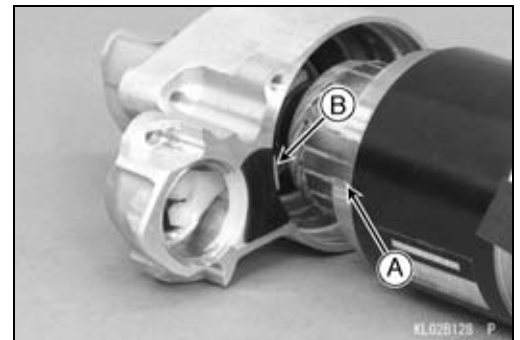

- Install the brush holder [A].
- Install the brushes [B] to the brush holder.

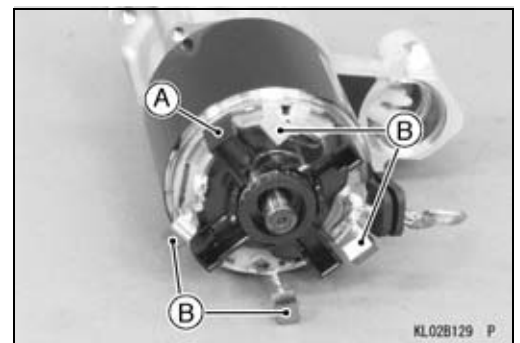

- Install the springs [A].

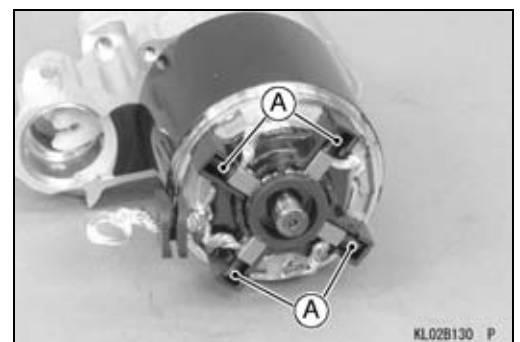

8-10 STARTER SYSTEM

Electric Starter System

- Install the insulator [A].

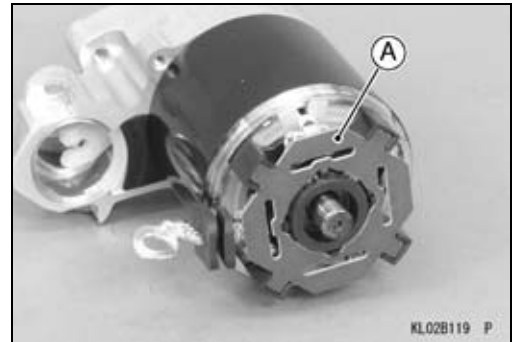

- Install the end cover so that the slit [A] fit the groove [B] of the grommet.
- Tighten the through bolts.



- Engage the hook on the starter solenoid with the hook [A] on the pinion gear fork [B].
- Tighten the solenoid mounting nut.

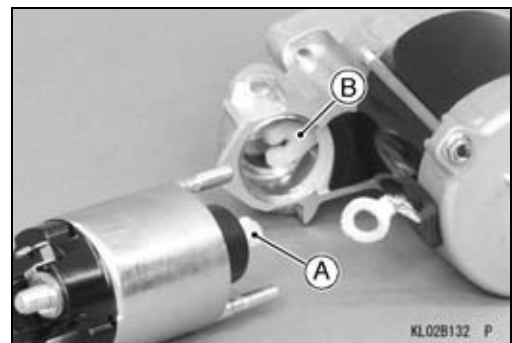

Starter Motor Brush Inspection

- Measure the overall length [A] of each brush.
- ★ If the brushes are shorter than the service limit, replace them.

Brush Length

Standard: 10.0 mm (0.39 in.)

Service Limit: 6.0 mm (0.24 in.)

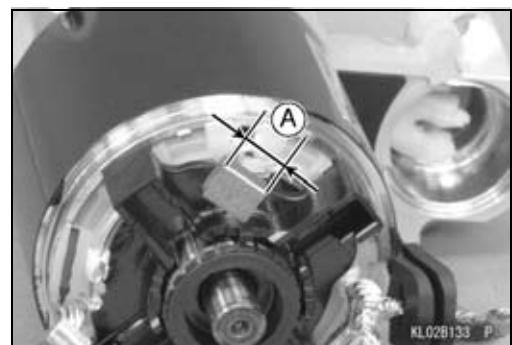

Brush Spring Inspection

- Inspect the brush springs for pitting, cracks, rusting and burrs. Replace the spring if necessary.
- Inspect the springs for weakened conditions and distortion. Replace the spring if necessary.
- ★ If the brush springs are able to press the brushes firmly into place, they may be considered serviceable. If they cannot, replace them.

Electric Starter System

Armature Inspection

- Inspect the surface of the commutator [A].
- ★ If it is scratched or dirty, polish it with a piece of very fine emery cloth [B], and clean out the grooves.

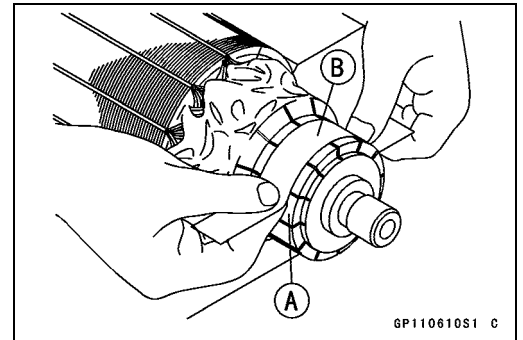

- Measure the depth of the grooves between the commutator segments.
- ★ If the grooves are shallower than the specified limit, replace the armature with a new one.
- ★ If the grooves are only dirty, clean them carefully.

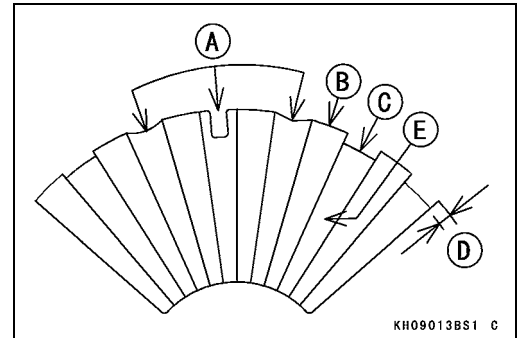

Commutator Groove Depth

- Standard:** 0.6 mm (0.02 in.)
- Service Limit:** 0.2 mm (0.008 in.)

- Bad [A]
- Segment [B]
- Good [C]
- 0.2 mm (0.008 in.) limit [D]
- Mica [E]

- Measure the outside diameter [A] of the commutator [B] at several points.
- ★ If the diameter is less than the service limit, replace the armature with a new one.

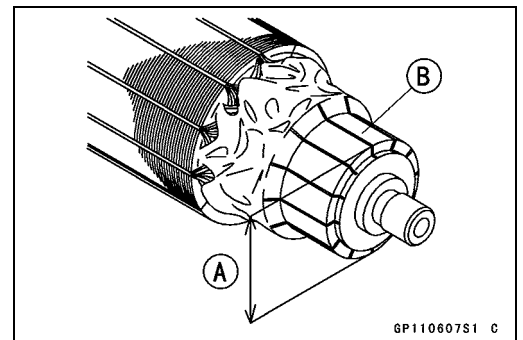

Commutator Outside Diameter

- Standard:** 28.0 mm (1.10 in.)
- Service Limit:** 27.0 mm (1.06 in.)

- Support the armature in an alignment jig at each end of the shaft as shown. Position a dial indicator perpendicular to the commutator.
- Rotate the armature slowly and read the commutator runout.
- ★ If runout is more than the service limit, replace the armature with a new one.

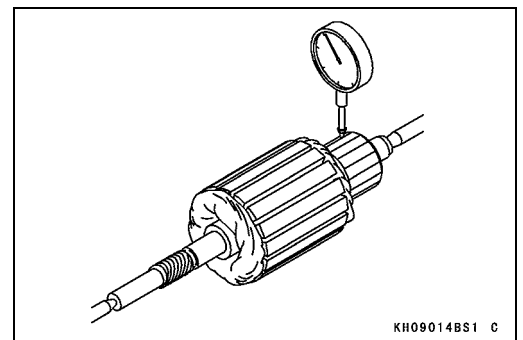

Commutator Runout

- Service Limit:** 0.4 mm (0.016 in.)

8-12 STARTER SYSTEM

Electric Starter System

- Measure the armature winding resistance.
- Set the multimeter selector switch to the $R \times 1 \Omega$ position and check the resistance between each segment and all the others.
- ★ If the resistance is too high or even infinite, the armature winding has an open circuit. Replace the starter motor.

Armature Winding Resistance

Close $\sim 0 \Omega$



- Set the multimeter selector switch to the $R \times 1 \text{ k}\Omega$ position and measure the resistance between the commutator and the armature shaft.
- ★ If the resistance is less than infinite, the armature is shorted.

Commutator to Shaft Resistance

(∞)



- Test the armature winding for shorts.
- Place the armature on a growler [A].
- Hold a thin metal strip (e.g., hack saw blade) on top of the armature.
- Turn on the growler and rotate the armature one complete turn.
- ★ If the metal strip vibrates, the windings are internally shorted to each other and the starter motor must be replaced.

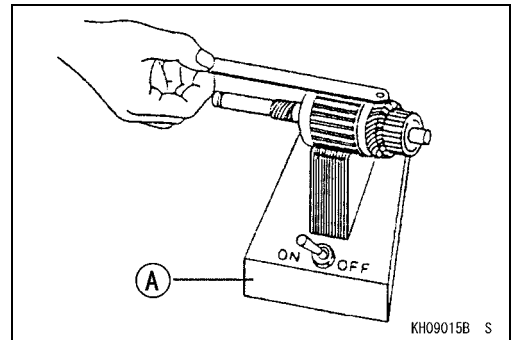

Yoke Assembly Inspection

- Set the multimeter selector switch to the $R \times 1 \text{ k}\Omega$ position and measure the resistance between the positive brushes and stator motor yoke.
- ★ If the resistance is less than infinite, the positive brush is shorted to ground. Replace the yoke assembly.

Positive Brush to Ground Resistance

(∞)

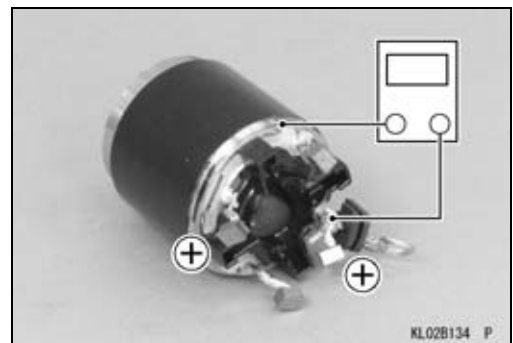

- Set the multimeter selector switch to the $R \times 1 \Omega$ position and measure the resistance between the negative brushes and starter motor yoke.
- ★ If the meter does not read close $\sim 0 \Omega$, the yoke assembly is faulty. Replace it.

Negative Brush to Ground Resistance

Close $\sim 0 \Omega$

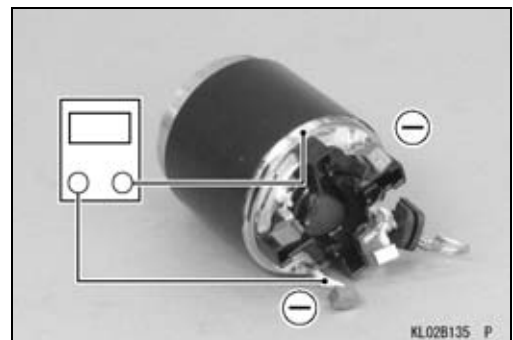

Electric Starter System

Pinion Clutch Inspection

- Remove the pinion clutch.
- Turn the pinion gear [A] by hand. The pinion gear should turn counterclockwise freely, but should not turn clockwise.
- ★ If the pinion clutch does not operate as it should, or if it makes noise, replace the pinion clutch.

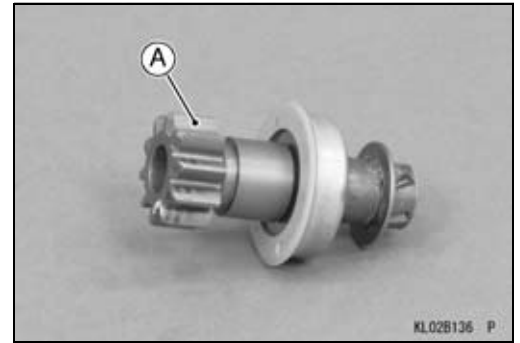

Electrical System

Table of Contents

Exploded View	9-2
Specifications	9-4
Special Tool	9-5
Wiring Diagram	9-6
Precautions.....	9-8
Charging System	9-9
Flywheel and Stator Coil Removal.....	9-9
Flywheel and Stator Coil Installation.....	9-10
Charging System Operational Inspection	9-12
Stator Coil Resistance	9-13
Unregulated Stator Output.....	9-13
Regulator Removal	9-13
Regulator Installation	9-13
Regulator Resistance.....	9-14
Ignition System	9-15
Ignition Coil Removal	9-15
Ignition Coil Installation	9-16
Ignition Coil Inspection.....	9-17
Spark Plug Removal	9-18
Spark Plug Installation	9-18
Spark Plug Cleaning and Inspection.....	9-18
Spark Plug Gap Inspection	9-18

9-2 ELECTRICAL SYSTEM

Exploded View

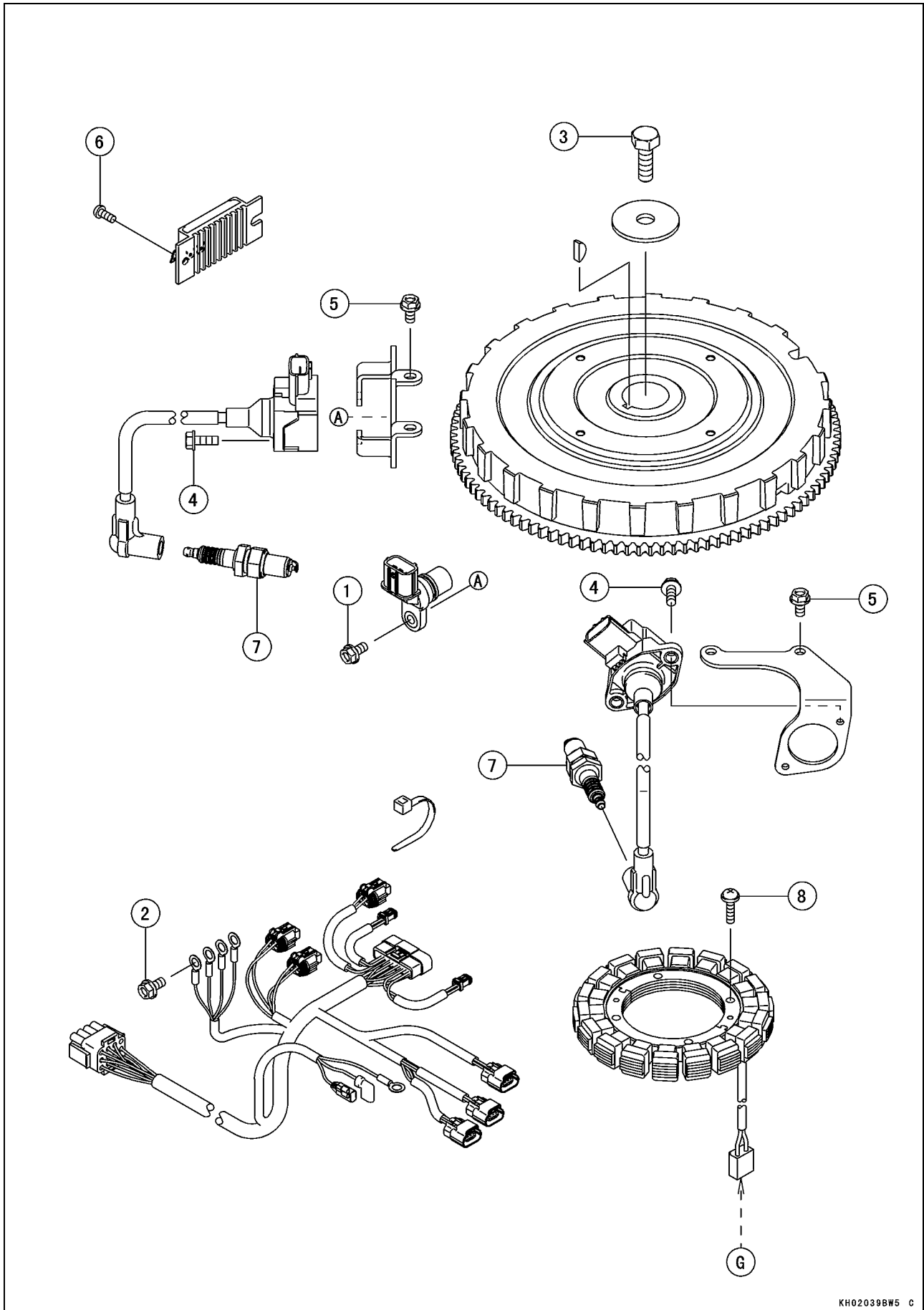

Exploded View

No.	Fastener	Torque			Remarks
		N·m	kgf·m	ft·lb	
1	Crankshaft Position Sensor Mounting Bolt	5.9	0.60	52 in·lb	
2	Engine Ground Terminal Bolt	5.9	0.60	52 in·lb	
3	Flywheel Bolt	56	5.7	41	
4	Ignition Coil Bolts	7.0	0.71	62 in·lb	
5	Ignition Coil Bracket Bolts	5.9	0.60	52 in·lb	
6	Regulator Screws	3.5	0.36	31 in·lb	
7	Spark Plugs	22	2.2	16	
8	Stator Coil Screws	3.4	0.35	30 in·lb	

G: Apply dielectric grease.

9-4 ELECTRICAL SYSTEM

Specifications

Item	Standard	Service Limit
Charging System		
Regulated Output Voltage	14.1 V DC	15 V DC
Stator Coil Resistance	0.1 ~ 0.14 Ω	— — —
Unregulated Stator Output	26 ~ 34 V AC/3 000 rpm	26 V AC/3 000 rpm
Regulator Resistance	in the text	— — —
Ignition System		
Crankshaft Position Sensor:		
Air Gap	0.5 ~ 0.7 mm (0.020 ~ 0.028 in.)	— — —
Spark Plug	NGK BPR5ES	— — —
Plug Gap	0.7 ~ 0.8 mm (0.028 ~ 0.031 in.)	— — —

Special Tool

Hand Tester:
57001-1394

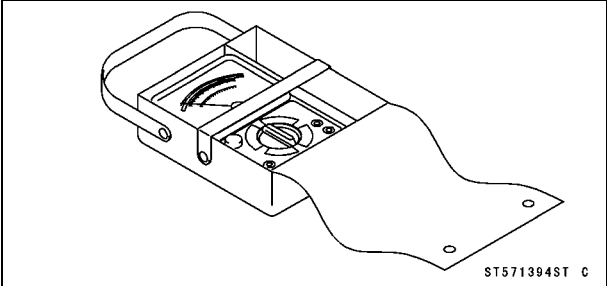

9-6 ELECTRICAL SYSTEM

Wiring Diagram

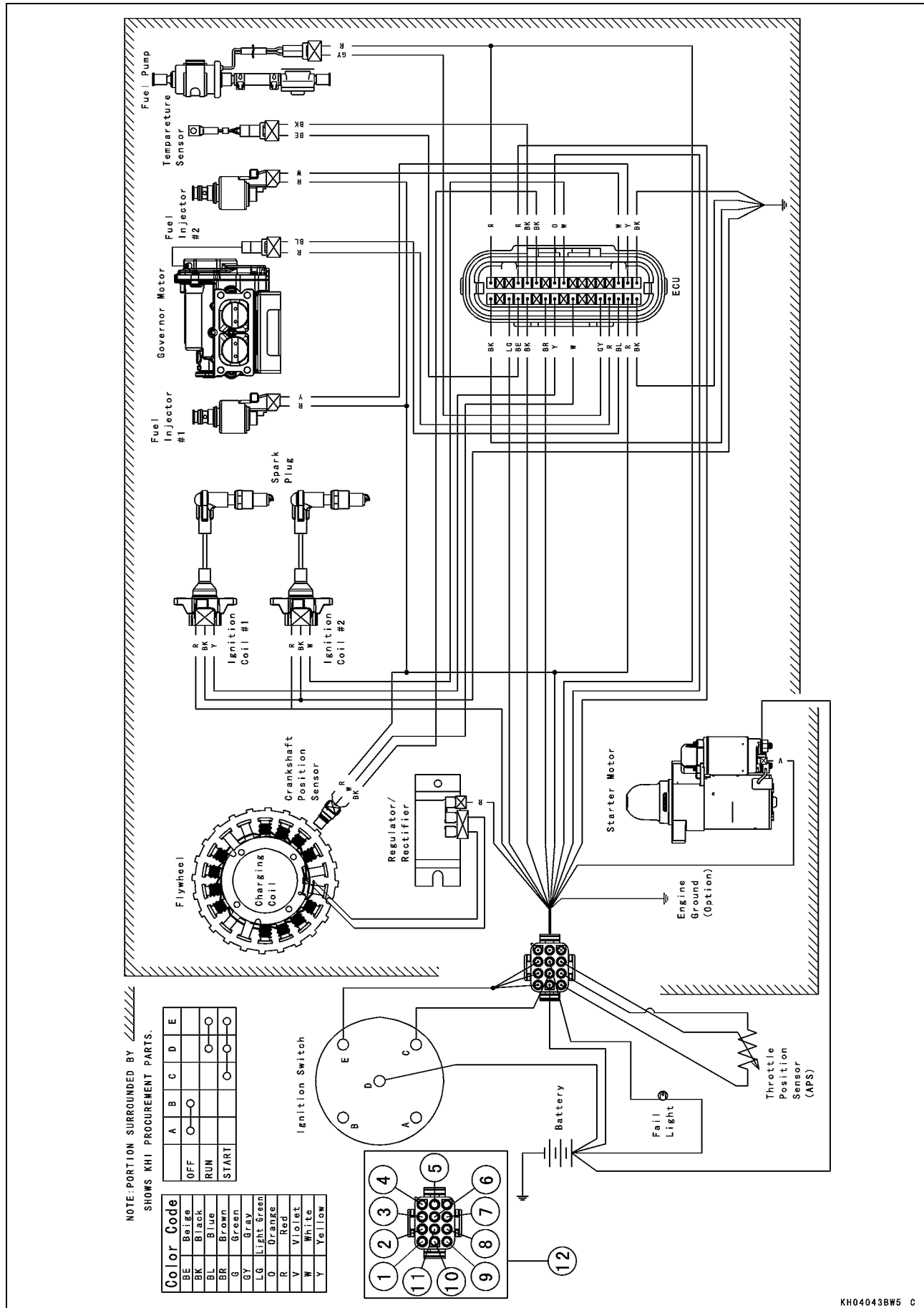

NOTE: PORTION SURROUNDED BY // SHOWS KHI PROCUREMENT PARTS.

Wiring Diagram

- 1. R
- 2. R
- 3. R
- 4. BK
- 5. BR
- 6. O
- 7. LG
- 8. R
- 9. BK
- 10. R
- 11. V
- 12. Engine Main Harness Connector

9-8 ELECTRICAL SYSTEM

Precautions

There are a number of important precautions that you must follow when servicing electrical systems. Learn and observe all the rules below.

- Do not reverse the battery cable connections. This will burn out the diodes in the electrical parts.
- Always check the battery condition before judging other parts of the electrical system. A fully charged battery is necessary for conducting accurate electrical system tests.
- Do not hit the electric parts with a hammer or do not drop the electric parts. These may result in the electric parts damage or breakage.
- To prevent damage to electrical parts, do not disconnect the battery cables or any other electrical connections when the engine switch is on, or while the engine is running.
- Because of the large amount of current, never keep the engine switch turned to the start position when the starter motor will not start, or the current may burn out the starter motor windings.
- Take care not to short the leads that are directly connected to the battery positive (+) terminal to the chassis ground.
- Troubles may involve one or all items in some cases. Never replace a defective part without determining what CAUSED the failure. If the failure was occurred by another item or some other items, repair and/or replace the item(s). Or the failure may happen again.
- Make sure all connectors in the circuit are clean and tight, and examine the leads for signs of burning, fraying, etc. Poor leads and bad connections will affect electrical system operation.
- Measure the coil and the winding resistance when the parts are cold (at room temperature).
- Electrical connectors:

Connectors [A]

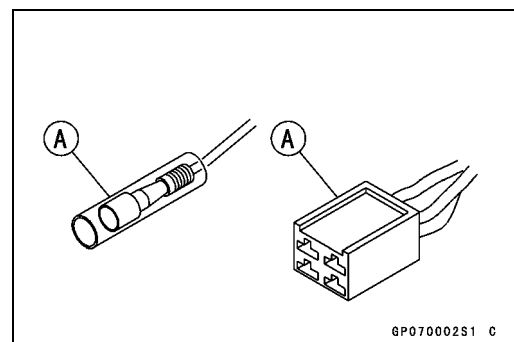

Connectors [B]

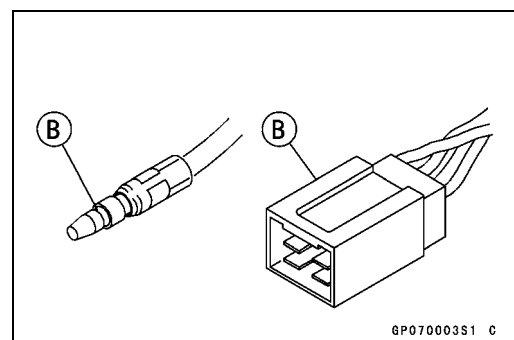

Charging System

Flywheel and Stator Coil Removal

- Remove:
 - Air Cleaner (see Air Cleaner Body and Bracket Removal in the Fuel System chapter)
 - Oil Cooler (see Oil Cooler Removal in the Lubrication System chapter)
 - Regulator (see Regulator Removal)
 - Fuel Pump (see Fuel Pump Removal in the Fuel System chapter)
 - Bolts [A] and Guard [B]

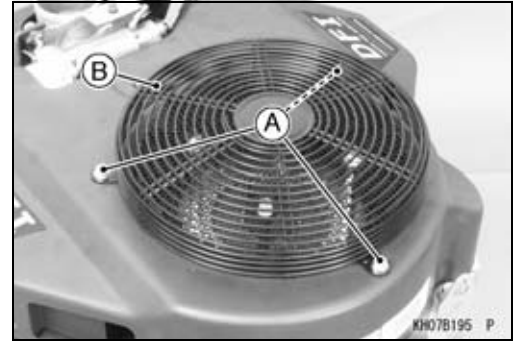

- Remove:
 - Bolts [A] and Screen [B]

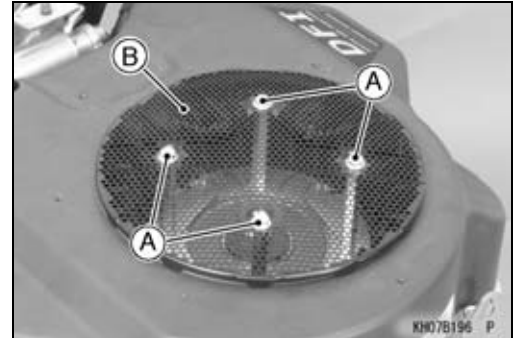

- Remove:
 - Bolts [A]
 - Fan Housing [B]

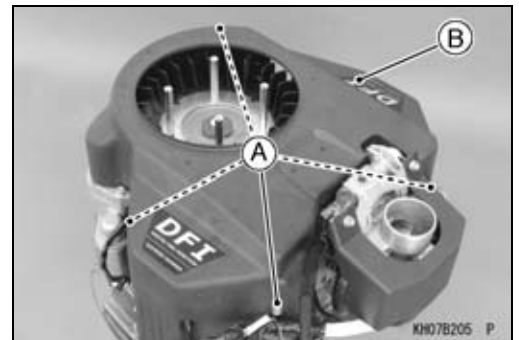

- Remove:
 - Ignition Coils (see Ignition Coil Removal)
 - Stud Bolts [A]
 - Plate [B]
 - Cooling Fan [C]

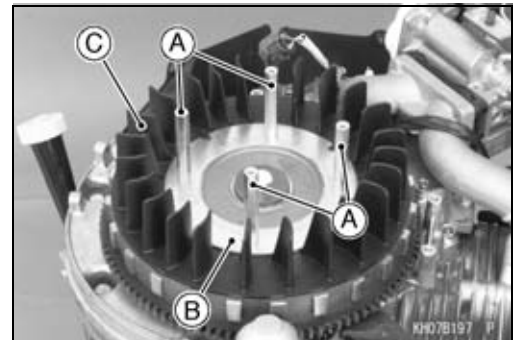

- Hold the flywheel with a suitable tool [A], remove the flywheel bolt [B] and the washer [C].

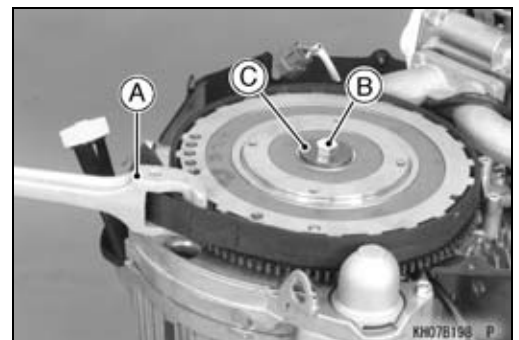

9-10 ELECTRICAL SYSTEM

Charging System

- Using a suitable flywheel puller [A], remove the flywheel [B].

CAUTION

Always use flywheel puller.

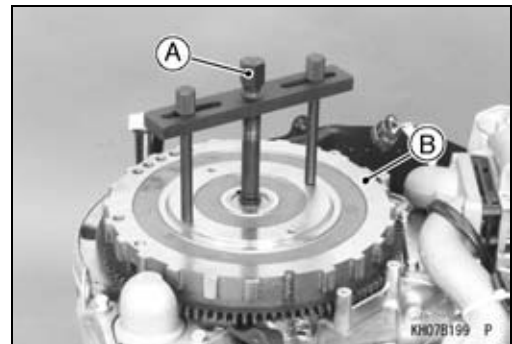

- Remove the bolt [A].

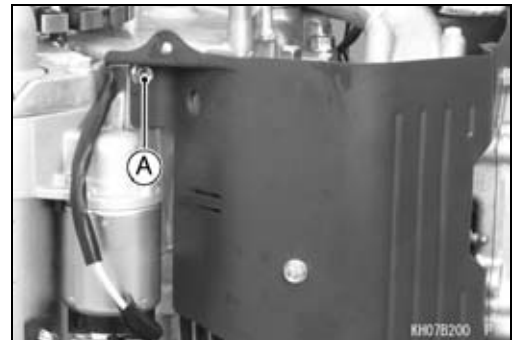

- Lift up the engine shroud [A] lightly and free the stator coil lead [B].

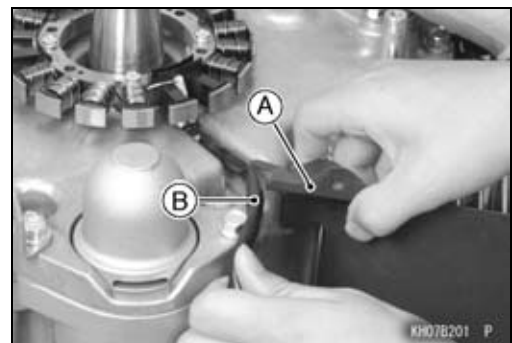

- Remove:
 - Woodruff Key [A]
 - Stator Coil Screws [B]
 - Stator Coil [C]

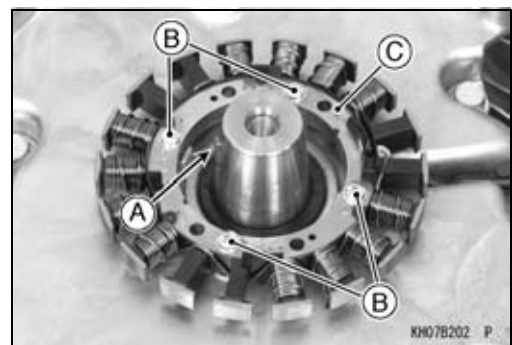

Flywheel and Stator Coil Installation

- Install the stator coil and tighten the screws.
Torque - Stator Coil Screws: 3.4 N·m (0.35 kgf·m, 30 in·lb)

Charging System

- Lift up the engine shroud [A] lightly and install the stator coil lead [B] in the original position.

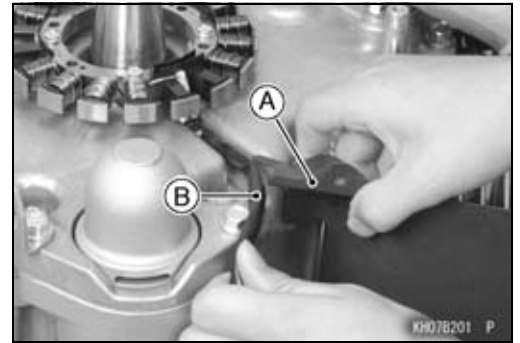

- Tighten the engine shroud bolt [A].
Torque - Engine Shroud Bolt: 5.9 N·m (0.60 kgf·m, 52 in·lb)

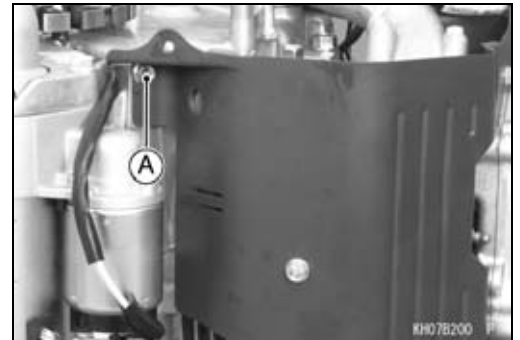

- Using a cleaning fluid, clean off any oil or dirt on the following portions and dry them with a clean cloth.
 Crankshaft Tapered Portion [A]
 Flywheel Tapered Portion [B]
- Fit the Woodruff key [C] securely in the slot in the crankshaft before installing the flywheel.

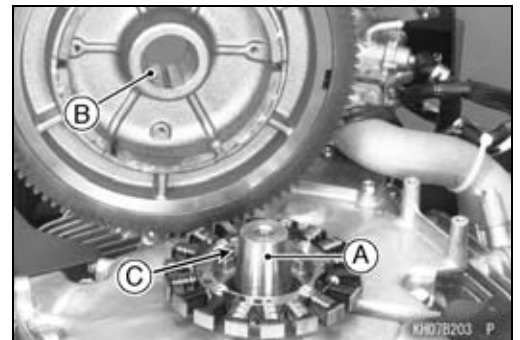

- Visually inspect the projections [A] of the flywheel [B].
- ★ If the projections are deformed or damaged, replace the flywheel with a new one.
- ★ If there is iron or other magnetic deposits, remove the deposits.

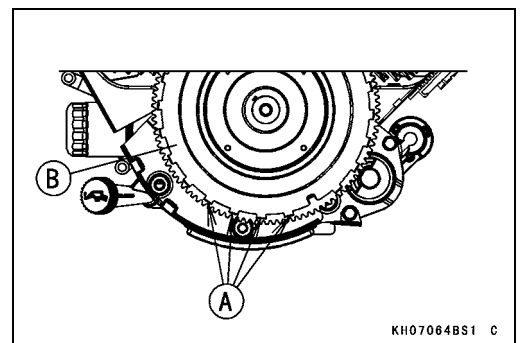

- Put the washer [A] as shown so that the "0" mark [B] faces up.
- Tighten:
Torque - Flywheel Bolt [C]: 56 N·m (5.7 kgf·m, 41 ft·lb)

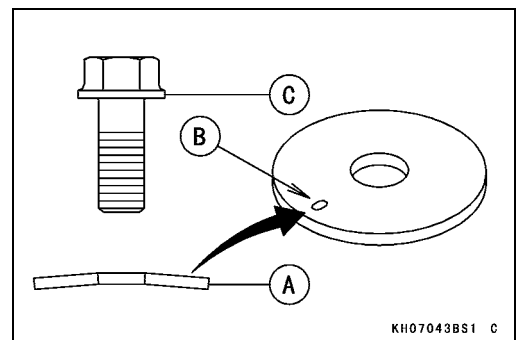

9-12 ELECTRICAL SYSTEM

Charging System

- Install the cooling fan [A].
- Install the plate [B] so that the slit [C] fit to the bosses [D] on the cooling fan.
- Tighten:
Torque - Cooling Fan Plate Mounting Stud Bolts: 5.9 N·m (0.60 kgf·m, 52 in·lb)

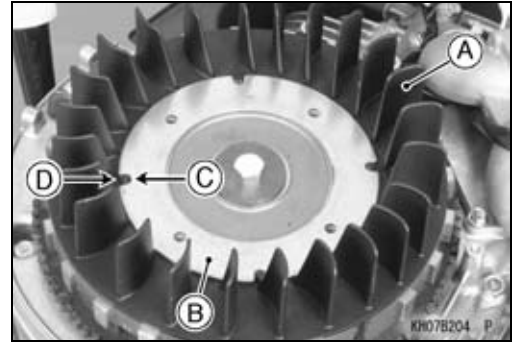

- Install the fan housing.
- Tighten:
Torque - Fan Housing Bolts: 5.9 N·m (0.60 kgf·m, 52 in·lb)
- Install the screen and guard.
- Tighten:
Torque - Cooling Fan Screen Bolts: 5.9 N·m (0.60 kgf·m, 52 in·lb)
Guard Mounting Bolts: 5.9 N·m (0.60 kgf·m, 52 in·lb)
- Install the removed parts (see appropriate chapters).

Charging System Operational Inspection

- Check the battery condition.

NOTE

○ *Always check the battery condition before judging other parts of the charging system. The battery must be fully charged for accurate charging system tests.*

- Warm up the engine to bring the components up to their normal operating temperatures.
- Measure regulated output voltage at various engine speeds.
- Connect a voltmeter across the battery terminals.
- ★ The readings should show nearly battery voltage when the engine speed is low, and as the engine speed rises, the readings should also rise. But they must stay within the specified range.
- ★ If the output voltage is much higher than the specification, the regulator is defective, or the regulator leads are loose or open.
- ★ If the output voltage does not rise as the engine speed increase, the regulator is defective or the alternator output is insufficient for the loads.

Regulated Output Voltage
Battery Voltage to 15 V DC

Charging System

Stator Coil Resistance

- Disconnect the stator coil lead connector [A].
- Measure the stator coil resistance.
- Connect an hand tester between stator pins [B].

Special Tool - Hand Tester: 57001-1394

Stator Coil Resistance

0.1 ~ 0.14 Ω

- ★ If the measured value is not within the specification, replace the stator coil with a new one.
- ★ If the coil has normal resistance, but the voltage inspection shows the alternator to be defective; the flywheel magnets have probably weakened, and the flywheel must be replaced.
- Check for continuity between each stator pin and ground. There should be no continuity (infinite ohm).
- ★ If the stator coil fails any of these tests, replace the coil with a new one.

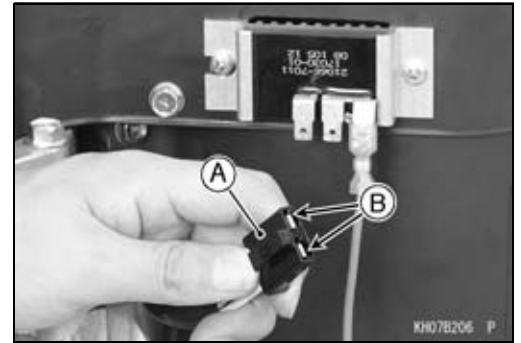

Unregulated Stator Output

- Disconnect the stator coil connector [A].
- Connect AC voltmeter to the stator pins [B].
- Start the engine. Run the engine at the 3 000 rpm speed.
- Voltage reading should be minimum 26 V AC/3 000 rpm.
- ★ If the AC voltage reading is less than the specification, replace the stator with a new one.

Unregulated Stator Output (MIN)

26 V AC/3 000 rpm

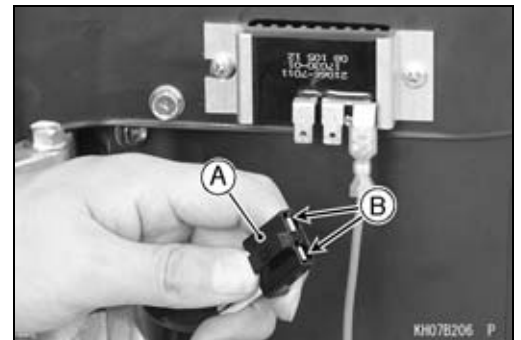

Regulator Removal

- Remove:
 - Regulator Lead Connector [A]
 - Stator Coil Lead Connector [B]
 - Regulator Screws [C]
 - Regulator [D]

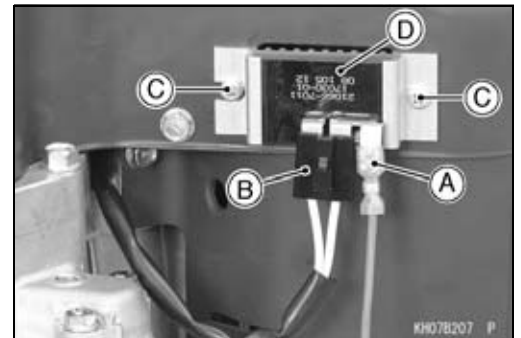

Regulator Installation

- Install the regulator [A] and tighten the screws [B].
 - Torque - Regulator Screws: 3.5 N·m (0.36 kgf·m, 31 in·lb)**
- Apply dielectric grease to the regulator terminals [C].
- Connect:
 - Stator Coil Lead Connector [D]
 - Regulator Lead Connector [E]

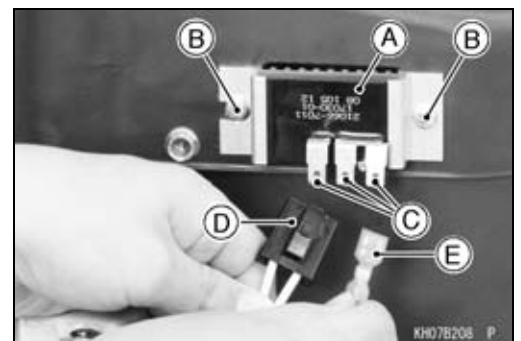

9-14 ELECTRICAL SYSTEM

Charging System

Regulator Resistance

- Remove the regulator (see Regulator Removal).
- Set the KAWASAKI Hand Tester selector switch to the R $\times 100 \Omega$ position.
- Connect the test leads to the points shown on the chart and read the resistance.

(Without Charging Monitor Type ...3 Blades)

	+	A	B	C	D
-					
A		-	∞	∞	∞
B		∞	-	0	∞
C		∞	0	-	∞
D		over than 1 M Ω	over than 1 M Ω	over than 1 M Ω	-

NOTE

○ Resistance value may vary with individual meters.

- ★ If the resistance is not as specified, replace the regulator with a new one.

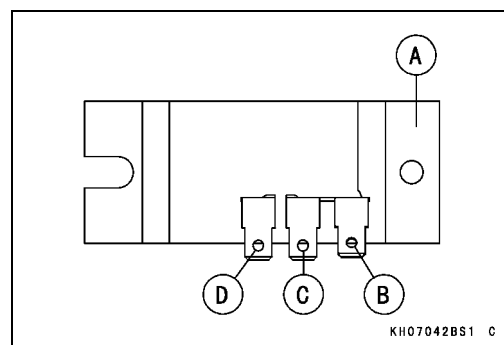

Ignition System

Ignition Coil Removal

- Remove:
 - Fan Housing (see Flywheel and Stator Coil Removal)
 - Spark Plug Caps [A]
 - Ignition Coil Connector [B]
 - Crankshaft Position Sensor Connector [C]

#1 Ignition Coil [D]

#2 Ignition Coil [E]

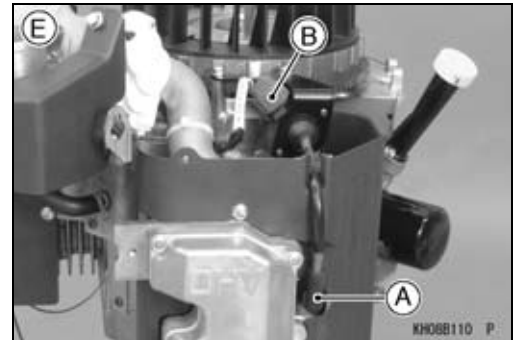
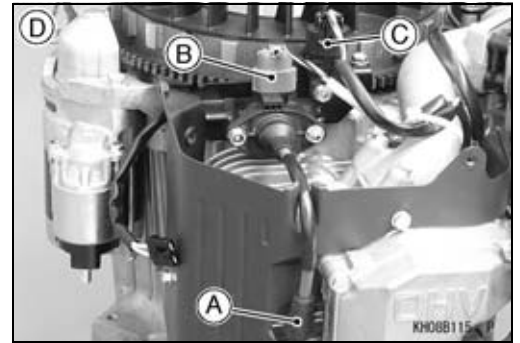

- Remove:
 - Bolts [A]
 - Ignition Coil Assembly [B]

#1 Ignition Coil [C]

#2 Ignition Coil [D]

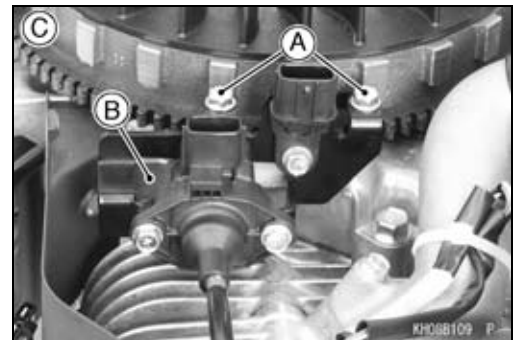

No.1 Ignition Coil

- Remove the bolts [A], crankshaft position sensor [B] and ignition coil [C] from the bracket [D].

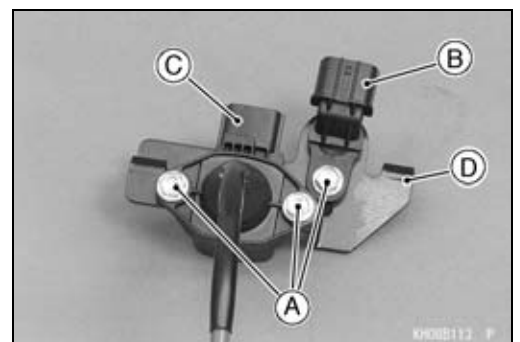

9-16 ELECTRICAL SYSTEM

Ignition System

No.2 Ignition Coil

- Remove the bolts [A] and ignition coil [B] from the bracket [C].

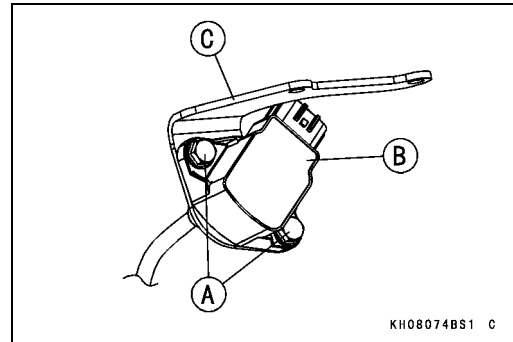

Ignition Coil Installation

No.1 Ignition Coil

- Install the ignition coil [A] and crankshaft position sensor [B] into the bracket [C].
- Tighten:

Torque - Ignition Coil Bolts [D]: 7.0 N·m (0.71 kgf·m, 62 in·lb)

Crankshaft Position Sensor Mounting Bolt [E]: 5.9 N·m (0.60 kgf·m, 52 in·lb)

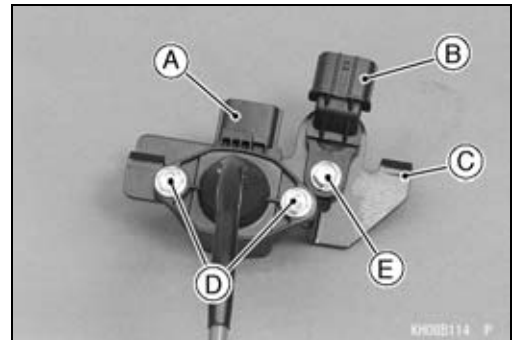

- Install the ignition coil assembly on the crankcase so that the ignition coil connector [A] face the upward, and tighten the bolt [B] first, then tighten the another bolt [C]. While tightening bolts, adjust the air gap [D] between the crankshaft position sensor [E] of ignition coil assembly and the projection [F] of the specified gap value as shown.

Crankshaft Position Sensor Air Gap

Standard: 0.5 ~ 0.7 mm (0.020 ~ 0.028 in.)

Torque - Ignition Coil Bracket Bolts: 5.9 N·m (0.60 kgf·m, 52 in·lb)

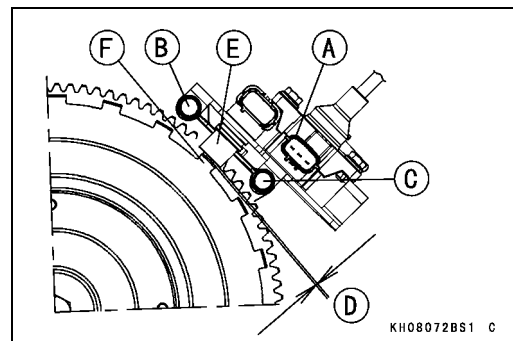

NOTE

○ Use the above procedure to insure proper coil air gap.

- Connect the ignition coil connector and crankshaft position sensor connector.

No.2 Ignition Coil

- Install the ignition coil [A] into the bracket [B].
- Tighten:

Torque - Ignition Coil Bolts [C]: 7.0 N·m (0.71 kgf·m, 62 in·lb)

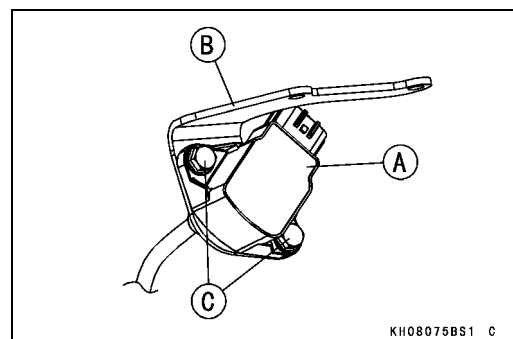

Ignition System

- Install the ignition coil assembly [A] on the crankcase, and tighten the bolts [B].

Torque - Ignition Coil Bracket Bolts: 5.9 N·m (0.60 kgf·m, 52 in·lb)

- Connect the ignition coil connector [C].

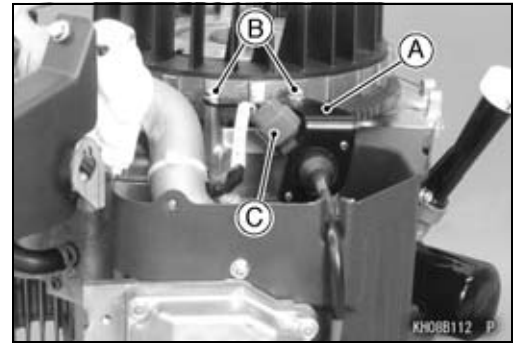

- Fit the ignition coil leads [A] to the each engine shroud groove [B].
- Install the spark plug caps [C].

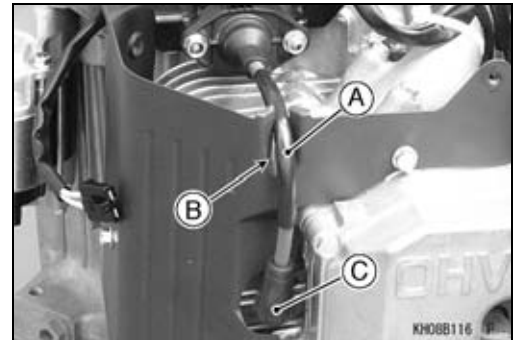

- Install the removed parts (see appropriate chapters).

Ignition Coil Inspection

- Disconnect the #1 and #2 ignition coil connectors (see Ignition Coil Removal).
- Measure the internal resistance as follows.
 - Set the hand tester to the R × 1 kΩ range.

Special Tool - Hand Tester: 57001-1394

- Measure the ignition coil internal resistance as shown in the table.

Ignition Coil Internal Resistance

	+	A	B	C	D
-					
A	-		5 ~ 200 kΩ	50 ~ 200 kΩ	∞
B	100 ~ 220 kΩ	-		1 ~ 5 kΩ	∞
C	100 ~ 220 kΩ	1 ~ 5 kΩ	-		∞
D	200 kΩ ~ 1 MΩ	1 ~ 10 MΩ	1 ~ 10 MΩ	-	

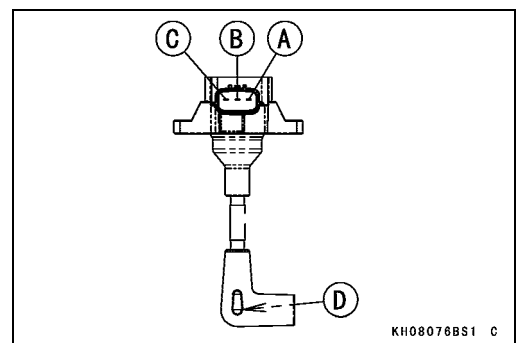

CAUTION

Use only Tester 57001-1394 with new battery at room temperature for this test. A tester other than the Kawasaki Hand Tester should show different readings.

If a megger or a meter with a large capacity battery is used, the ignition coil will be damaged.

- ★ If the tester does not read as specified, replace the coil with a new one.

NOTE

- Even if the foregoing checks show the ignition coil to be good, it may be defective in some manner not readily detectable with the hand tester.

9-18 ELECTRICAL SYSTEM

Ignition System

Spark Plug Removal

- Carefully pull the plug caps from the spark plugs.
- Remove the spark plugs using a suitable plug wrench.

Spark Plug Installation

- Insert the spark plug vertically into the plug hole with the plug installed in the plug wrench.
- Tighten the plugs.

Torque - Spark Plugs: 22 N·m (2.2 kgf·m, 16 ft·lb)

- Fit the plug caps securely.
- Pull up the spark plug caps lightly to make sure of the installation of the spark plug caps.

Spark Plug Cleaning and Inspection

- Refer to the Spark Plug Cleaning and Inspection in the Periodic Maintenance chapter.

Spark Plug Gap Inspection

- Refer to the Spark Plug Gap Inspection in the Periodic Maintenance chapter.

Troubleshooting

Table of Contents

Engine Troubleshooting Guide	10-2
DFI System Troubleshooting	10-6
Starter Motor Troubleshooting Guide	10-7

10-2 TROUBLESHOOTING

Engine Troubleshooting Guide

If the engine malfunctions, check if the way the engine is used is correct. If the engine malfunctions even if the engine is used correctly, systematically carry out troubleshooting starting with simple points.

This chart describes typical troubleshooting procedures.

Do not unnecessarily disassemble the engine unless it has been found to be the cause of malfunctioning.

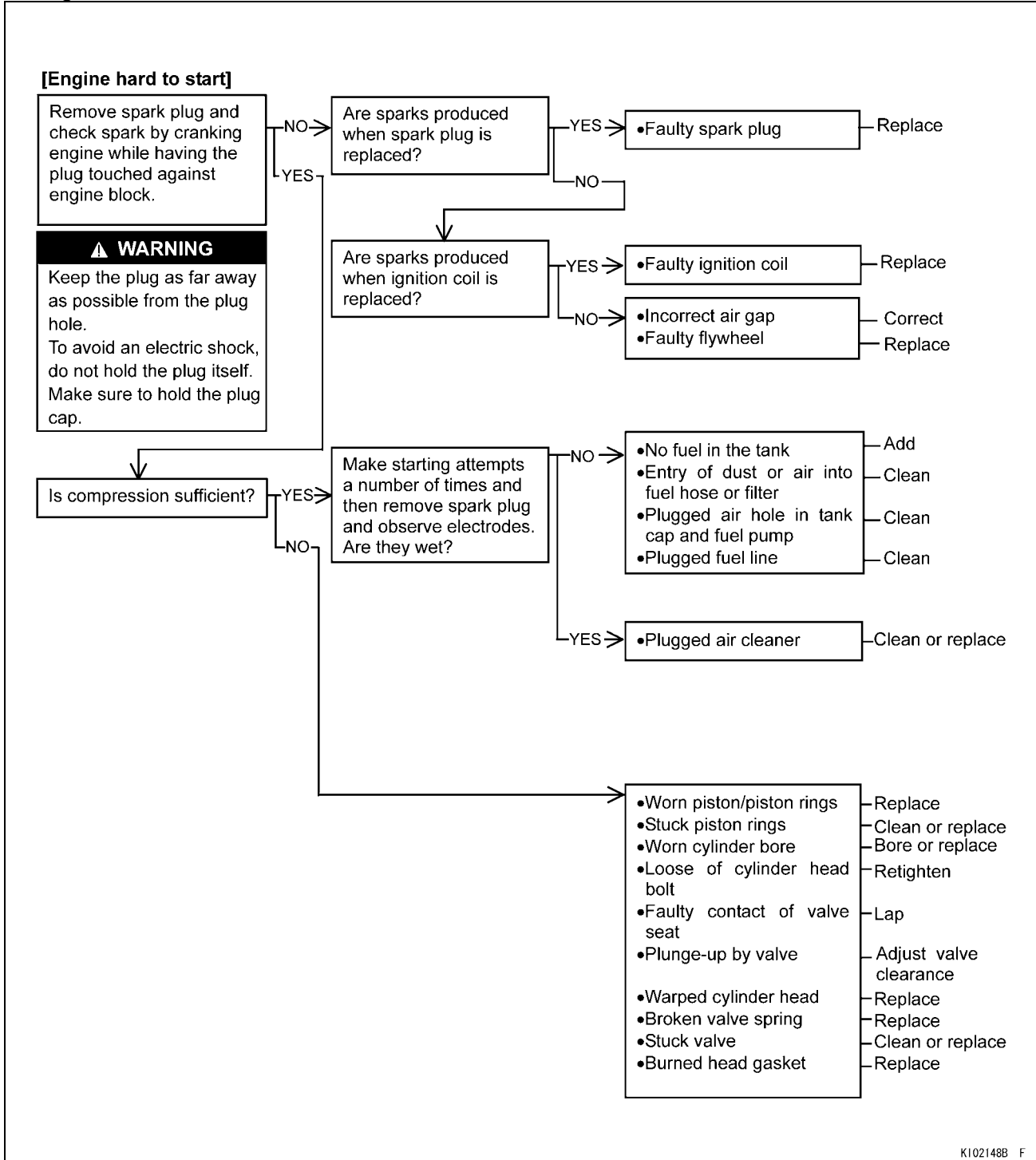

Engine Troubleshooting Guide

[Engine power loss]

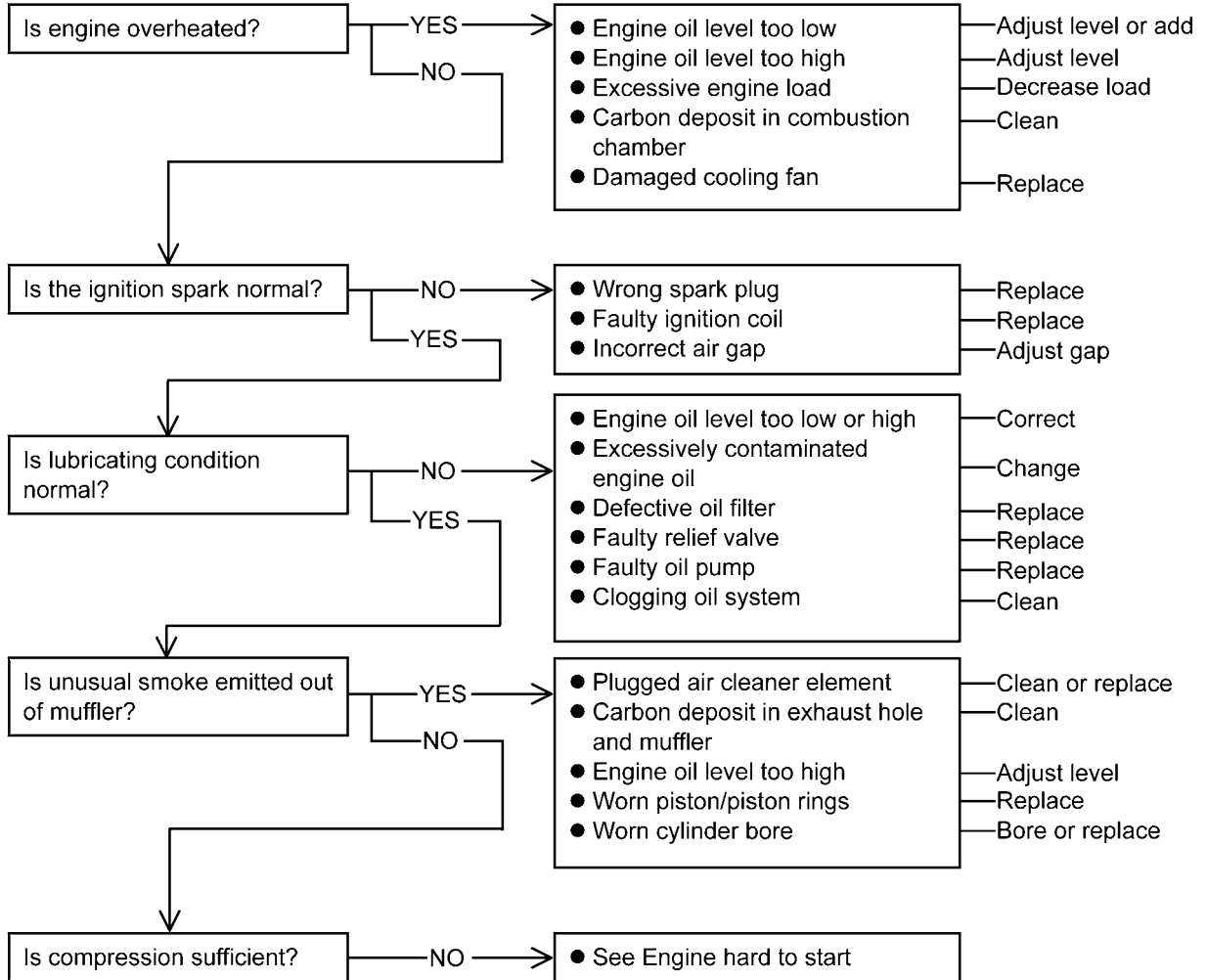

[Engine runs erratically]

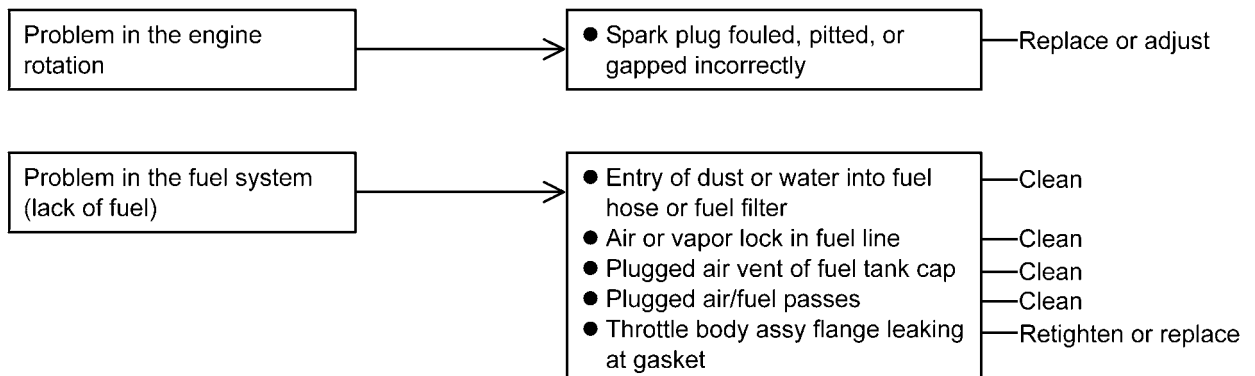

10-4 TROUBLESHOOTING

Engine Troubleshooting Guide

[Engine malfunctions at high speed]

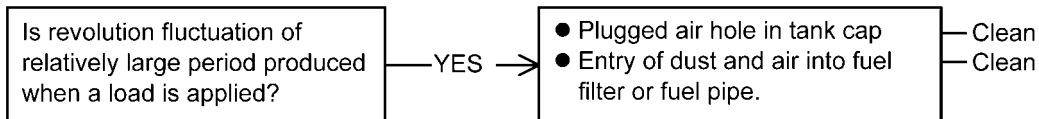

[Engine malfunctions at low speed]

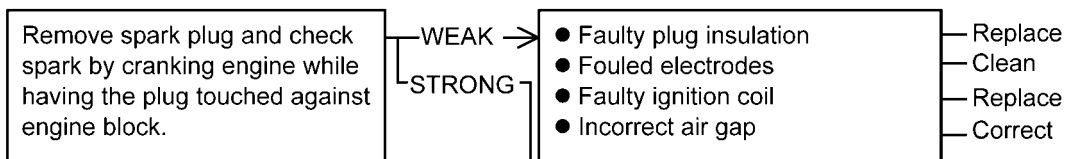

⚠ WARNING

Keep the plug as far away as possible from the plug hole. To avoid an electric shock, do not hold the plug itself. Make sure to hold the plug cap.

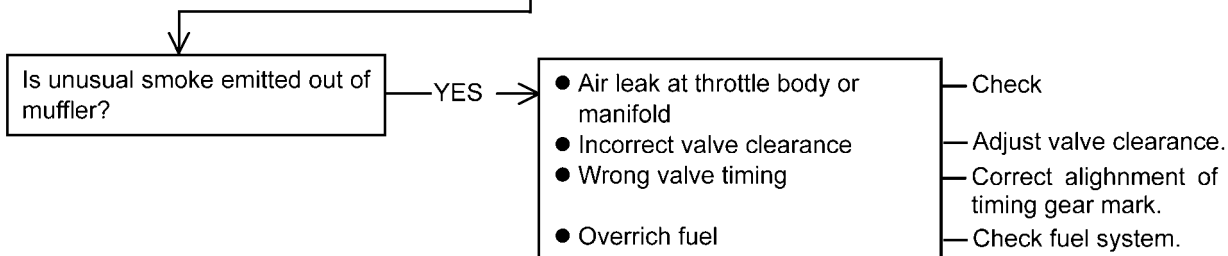

Engine Troubleshooting Guide

[Fuel consumption is excessive]

Is compression sufficient?

- Worn piston/piston rings
- Stuck piston
- Worn cylinder bore
- Loose of cylinder head bolt
- Faulty valve seat contact
- Plunge-up of valve
- Wrong valve timing
- Broken valve spring
- Stuck valve

- Replace
- Clean or replace
- Bore or replace
- Retighten
- Lap
- Adjust valve clearance
- Adjust
- Replace
- Clean or replace

[Oil consumption is excessive]

Is compression sufficient?

YES
NO

- Plugged oil ring groove
- High oil level
- Worn valve stem and valve guide
- Oil leakage from oil seal
- Oil leakage from mounting surface
- Oil leakage from drain bolt
- Clogged breather valve
- Drain-back hole in breather chamber plugged
- Incorrect oil viscosity

- Clean
- Adjust
- Replace
- Replace
- Replace gasket
- Retighten or replace gasket
- Clean
- Clean
- Correct

- Worn piston rings
- Stuck piston rings
- Worn cylinder bore
- Broken piston ring

- Replace
- Clean or replace
- Bore or replace
- Replace

[Engine backfires]

- Loose throttle body assy or intake manifold
- Loose cylinder head bolt or leaking head gasket
- Burned or sticking inlet valve
- Faulty ignition coil

- Retighten
- Tighten
- Replace
- Replace

[Engine knocks]

- Stale fuel
- Excessive carbon deposit in engine
- Excessive engine load
- Engine overheating
- Faulty ignition coil

- Change
- Clean
- Adjust
- See Engine power loss
- Replace

10-6 TROUBLESHOOTING

Engine Troubleshooting Guide

DFI System Troubleshooting

Troubleshooting guide shows the relationship between systems and inspection items which could be causing the trouble.

Symptoms →		Engine will not start																									
		Engine starts but falls to keep running		Engine runs but misses		Engine will not idle		Engine runs erratically		Engine loses power		Engine does not maintain constant speed (surges)		Engine overheats		Engine knocks		Engine back fires		Engine after fires		Exhaust smokes excessively		Excessive fuel consumption			
Operations ↓	Fuel pump inspection	●	●			●			○																		
	Fuel pump relay inspection	●	○																								
	Fuel injection	Aural inspection	●	○			●	○	○												○		○				
		Injector signal inspection	○				○				○	○	○	○	○												
	Crankshaft position sensor inspection	●	●																								
	Fuel pressure inspection	●	●	●	●	○	●	●	●	●	●	○	●	●													
	Fuel leak inspection	○	○			○	○	●		●	●		○		●												
	Fuel system cleaning	○	○			○	●	●	○	○			○	○	●	●											
	Fuel filter inspection	○	○			○	○	●	○				○	○	○	○											
	Engine temperature sensor inspection	○		○				○	○	○	○		●	●	●	●											
	Throttle valve inspection		●			●	●			●																	
	Harness inspection	●	●	○		●	●	○	●	●	●	●	●	●	○												
	Air leak inspection	○	○			●	●	○	●	●	●	○	○														
	Replace ECU	●	○	○	○	○	○	●	○	○	○	○	●	○	●	●											

NOTE

○ For troubles in digital fuel injection system only. Prerequisite is that the ignition system and the engine be in satisfactory condition.

- : Main inspection items
- : Subordinate inspection items

Starter Motor Troubleshooting Guide

1. Disconnect spark plug caps from the spark plugs.
2. Turn engine switch to "START" position and check condition.

⚠ WARNING

Engine may be cranked in this test. Do not touch any rotating parts of engine and equipment during test.

CAUTION

If starter does not stop by engine switch OFF, disconnect negative (-) cable from battery as soon as possible.

[Starter does not rotate]

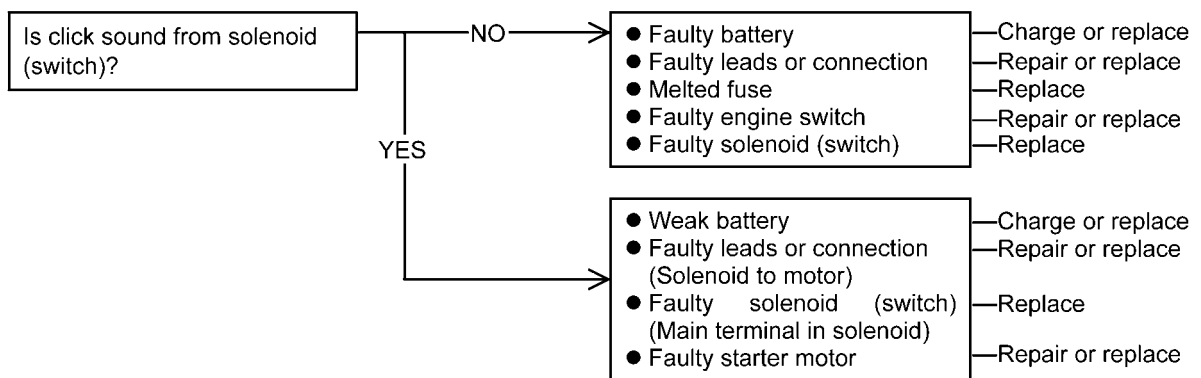

[Starter rotates but slow]

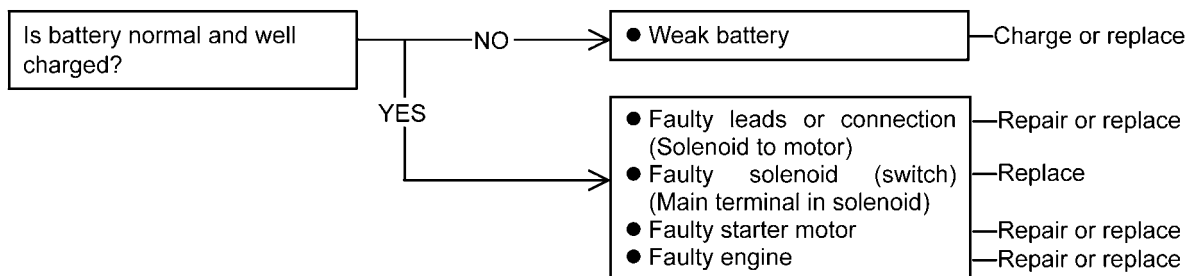

[Starter rotates but engine can not crank]

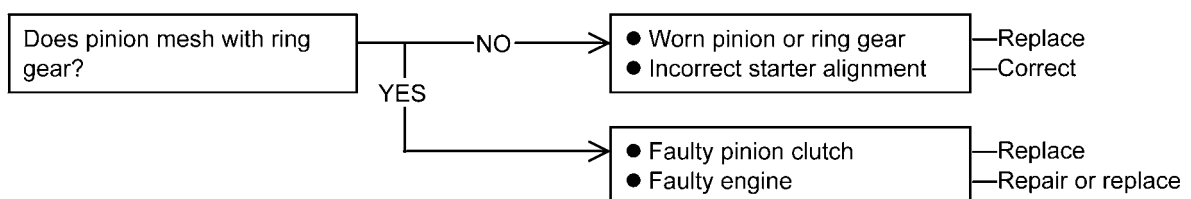

[Starter does not stop in engine switch "OFF"]

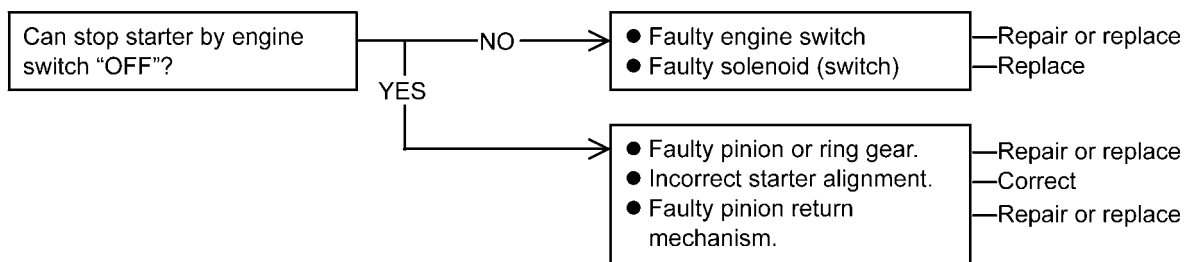



KAWASAKI HEAVY INDUSTRIES, LTD.
Consumer Products & Machinery Company

Part No.99924-2095-01

Printed in Japan