

-30 C Undercounter Plasma Freezer

Order parts online
www.follettice.com

Installation, Operation and Service Manual

Serial numbers C45184 and above

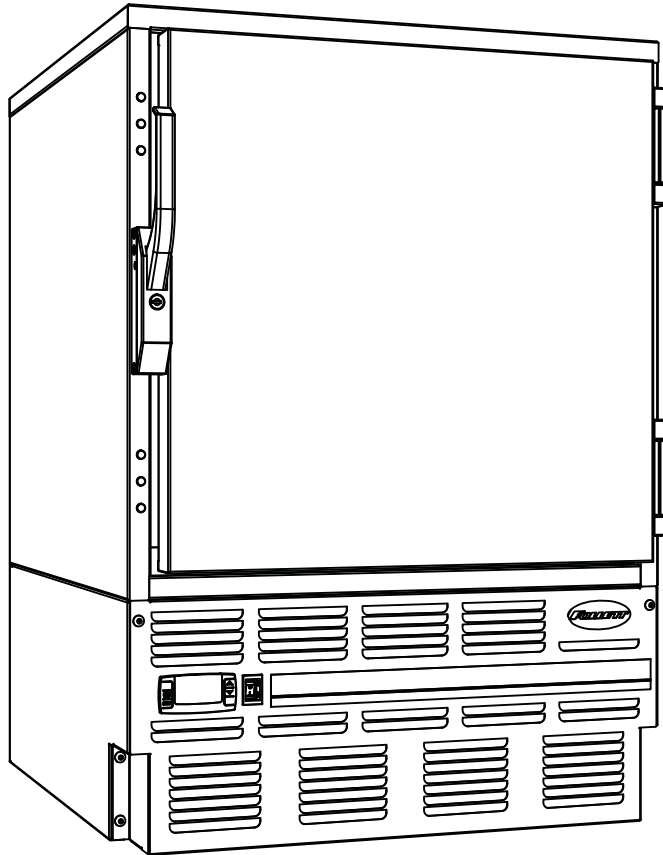

**Following installation, please forward this manual
to the appropriate operations person.**

Welcome to Follett

Follett equipment enjoys a well-deserved reputation for excellent performance, long-term reliability and outstanding after-the-sale support. To ensure that this product delivers that same degree of service, we ask that you take a moment to review this manual before beginning the installation. Should you have any questions or require technical help at any point, please call our technical service group at (800) 523-9361 or (610) 252-7301.

Before you begin

After uncrating and removing all packing material, inspect the equipment for concealed shipping damage. If damage is found, notify the shipper immediately and contact Follett Corporation so that we can help in the filing of a claim, if necessary.

Specifications

Series specifications

FZR5-PL

34" height for freestanding use or installation below standard 36" (915mm) high counter

2 drawers - up to 40 (350ml) plasma cartons

Maximum drawer load - 35 lbs (16kg) each.

Electrical specifications

115V, 60Hz, 1 phase

Full load amps: 8.0

Minimum circuit ampacity: 15 amp

Maximum size of branch circuit overcurrent device: 15 amp

Refrigeration specifications

Refrigerant – R404A

Charge size – 10 oz

Maximum design pressures:

High side – 383psi

Low side – 175psi

Installation specifications

Ambient temperature must not exceed 30 C (86 F).

The front louvered panel must be kept free of any cabinet trim or obstructions to ensure proper ventilation of the refrigeration system.



Important cautions

- Equipment must be wired according to local and NEC codes.
- Always disconnect power before servicing freezer.

Installation

Installing legs – required

1. Remove legs from plastic bag packed inside freezer.
2. Tip freezer back and screw legs in all the way to stop (they will extend 1/8" below base of freezer).
3. Adjust legs as needed to level freezer in both directions. To access legs, remove the lower front panel. Turn legs clockwise to extend legs.

Fig. 1

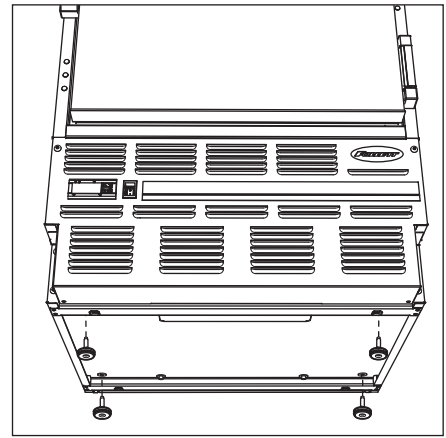

Temperature surveillance module

Follett's all-in-one temperature alarm and chart recorder module (manufactured for Follett by Dickson) may be included with your FZR5-PL. Please refer to the Dickson instructions packed with this module for set-up and operation instructions.

Follett's monitoring bottle and temperature probe has already been installed in the Follett FZR5-PL. Simply connect the loose end of the probe wire on the back of the unit to the surveillance module to complete the install.

A box of sixty (60) -50 to +50 7-day charts have also been included with this module. Replacement charts and pens can be ordered from Follett by calling Technical Service at 800-523-9361:

Item # 00162099 — Box of sixty (60), -50 to +50, 7-day replacement charts

Item # 00162081 — Box of six (6) replacement red pens

Charts with different temperature scales are also available. Contact Dickson at www.dicksondata.com

Reversing the door swing – optional

NOTICE

When reinstalling latch and hinge screws, 242 blue Loctite* MUST be applied to screws. Torque screws to 25 in-lbs.

1. Remove screws and latch from refrigerator cabinet (Fig. 2.1).
2. Use flat screwdriver to carefully remove (do not scratch) hinge covers (Fig. 3.1).
3. Support door and remove screws attaching hinge to refrigerator cabinet (Fig. 3.2).
4. Cover hinge screw holes with screw hole plugs removed from opposite side.
5. Reverse door. Apply 242 blue Loctite to hinge screws and reinstall torqued to 25 in-lbs.
6. Reinstall latch on opposite side.
7. Remove screws and handle from door (Fig. 4.1).
8. Rotate handle (Fig. 4.2).
9. Apply 242 blue Loctite to latch screws and reinstall torqued to 25 in-lbs.

Fig. 2

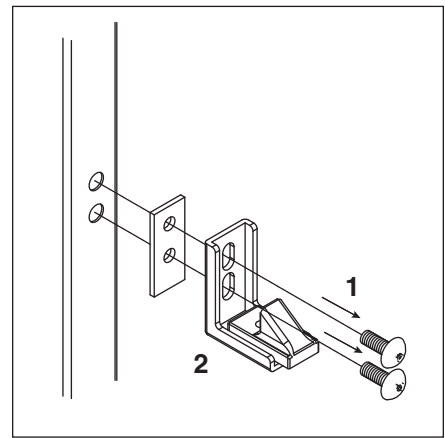

Fig. 3

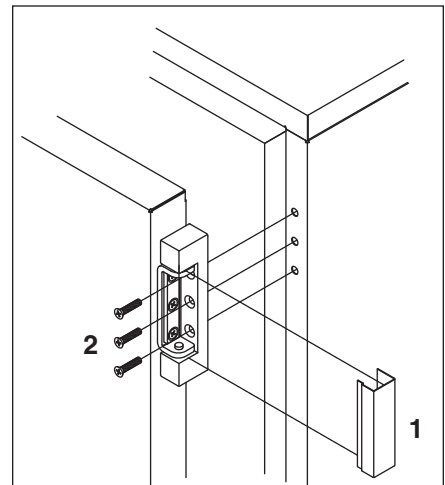
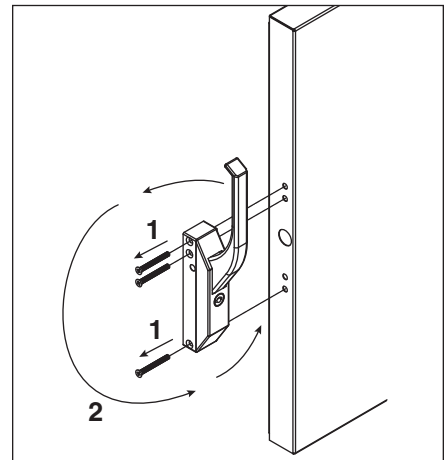

Fig. 4



*Loctite is a registered trademark of Henkel Corporation in the United States and other countries.

Controller operation

In normal operation the controller displays cabinet temperatures in degrees C (default) or user-selected degrees F.

The controller is pre-programmed with a -35 C (-31 F) set point which provides a compressor cut-in at -33 C (-27F) and cut-out at -35 C (-31 F). The controller set point can be raised to -25 C (-13 F) when a lower temperature is not desired. Follow instructions for changing temperature cut-out below.

All set points have a 2 C differential. The 2 C differential means that with a -35 C set point, for example, the compressor will turn off at -35 C (-31 F) and turn on when the cabinet reaches -33 C (-27 F).

This temperature may not reflect the temperature of the blood products in the freezer. The temperature of the blood products will be reflected on the recorder chart and the recorder's digital temperature display. At times there may be a difference between the two displayed temperatures. Adjust the controller SET value to achieve your desired blood product temperature as displayed on your chart recorder.

Fig. 5

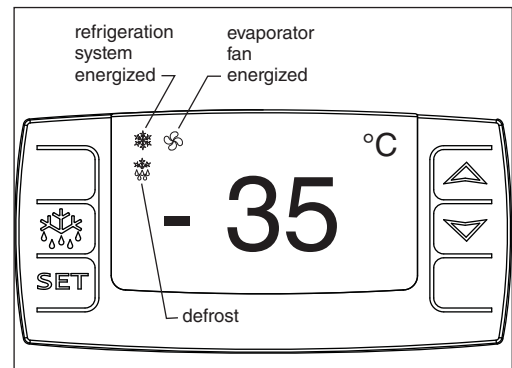

To display temperature cut-out

STEP	INPUT	DISPLAY
1	Press and release SET	Current cut-out temperature will display for approximately 5 seconds. Display will return to current refrigerator temperature.

To change temperature cut-out

STEP	INPUT	DISPLAY
1	Press and hold SET for 3 seconds	Current cut-out temperature displayed and °C will flash
2	Press UP or DOWN arrows to desired cut-out temperature	New cut-out temperature displayed
3	Press and release SET	New cut-out temperature blinks three times, then current refrigerator temperature will display

Programming freezer from a key (download)

1. TURN OFF freezer.
2. Remove 6 screws from panel holding controller to access back of controller.
3. Insert degree F programmed key into 5 PIN receptacle on controller back.
4. TURN ON freezer.
5. Values from key automatically download to freezer ("dol" message blinks followed by "end").
6. After 10 seconds display returns to current freezer temperature and controller will restart with new values.
7. TURN OFF.
8. Remove key.
9. Reinstall panel.

Note: An "Err" message displays for failed programming. Turn freezer OFF then ON to restart download, or remove key to abort.

Controller security

The controller panel can be locked to prevent inadvertent or intentional programming changes. In locked mode, the controller will display cabinet temperature and cut-out set point only.

To lock the controller

1. Press the UP and DOWN ARROW buttons together for 3 seconds until "PoF" displays (will flash 3 times).
2. Programmer is now locked.

To unlock the controller

1. Press UP and DOWN ARROW buttons together for 3 seconds until "Pon" displays (will flash 3 times).
2. Programmer is now unlocked.

Controller programming key degrees C (optional accessory)

A controller programming key is available from Follett to provide fast and easy reprogramming of factory settings (part# 00193391).

Operation

The temperature controller and probe indicate when the refrigeration system is required to turn on and off.

The refrigeration system removes heat from the cabinet interior and rejects it to the surrounding room air. When the cabinet interior temperature reaches 2 C (4 F) above the controller set point, the probe signals the controller to turn the refrigeration system on. The normally-open controller contacts 4 and 5 close and energize the evaporator and condenser fan motors, compressor and door heater. The snowflake and fan LED's on the controller will come on to indicate the refrigeration system is on. The compressor uses a current-style starting relay and a starting capacitor to start the compressor motor.

When the cabinet interior temperature falls to the set point, the probe signals the controller to turn the refrigeration system off. The controller contact 5 reopens, which de-energizes the condenser fan motor and the compressor. The snowflake LED will go out, the fan LED will remain on.

Any accumulated frost on the evaporator coils melts during the defrost cycle. Freezer products will remain at or below -20 C (-4 F) during the defrost cycle. The condensate drains to a drain pan mounted along the condensing unit. The heat from the condensing unit evaporates any condensate in the drain pan.

Temperature control

The temperature control system is preset by the factory to maintain a cabinet temperature of -33 C (-27 F). If desired, the cut-out temperature can be raised as high as -25 C (-13 F) by following the instructions on page 6 for changing the temperature set point. The 2 C cut-out differential will be maintained regardless of the controller set point.

Defrosting

The FZR5-PL undercounter freezer controls frost accumulation on the evaporator through automatic timed defrost cycles. The defrost cycle is initiated by the temperature controller every 4 hours. Contacts 4 and 5 on the controller open and the refrigeration system is turned off. Contact 2 is closed and the defrost heater is energized. The melting snowflake LED on the controller will come on, and the temperature display will read: "dEF" to indicate the freezer is in the defrost cycle.

The heater warms the evaporator coil and drain pan to melt the frost and drain the water to the condensate pan. The temperature controller monitors evaporator temperature using a probe embedded in the coil. The controller terminates the defrost cycle when the evaporator temperature reaches 5 C (41 F) or after 25 minutes of defrost time, whichever occurs first. As the defrost cycle terminates, the controller de-energizes the heater and restarts the compressor and condenser fan. The snowflake LED on the controller will come on to indicate the refrigeration system is running.

There is a 10 minute delay before the evaporator fan motor is re-energized. The fan LED on the controller will come on to indicate the fan is running and the temperature display resumes displaying cabinet temperature. A defrost cycle can be initiated manually at any time by depressing and holding the melting snowflake button for approximately three seconds. As a safety feature, a temperature safety switch mounted on the evaporator will turn off the defrost heater if the temperature of the evaporator reaches +27 C (+80 F) regardless of controller operation.

Cleaning



Use only non-chlorine-based cleaners. Cleaners containing chlorine can cause staining and pitting of the stainless steel.

Interior – Using a sponge or soft cloth, clean unit with a non-abrasive, non-chlorinated, all-purpose detergent.

Exterior – Wipe exterior with a soft cloth in the direction of grain as needed. Stainless steel polish may be used to enhance the finish of the unit.

Annual cleaning

Removal of dust and other particulates from air intake areas and the condenser is important for proper operation. Some environments with large amounts of dust may require more frequent cleaning.

1. Disconnect power to unit by turning switch on the lower front panel to the OFF position, switching circuit breaker to OFF position, and removing power cord from receptacle.
2. Remove lower front panel (Fig. 6.1).
Note: Front louvered panel may be completely removed for easier cleaning by disconnecting the controller wiring plugs from the freezer.
3. Remove drain pan (Fig. 6.2).
4. Clean drain pan with a non-abrasive, non-chlorinated all-purpose detergent.
5. Reinstall drain pan.
6. Use a vacuum cleaner with brush attachment to clean condenser through lower front panel and compressor motor and related parts through lower rear panel.
7. Reinstall lower front panel.

Fig. 6

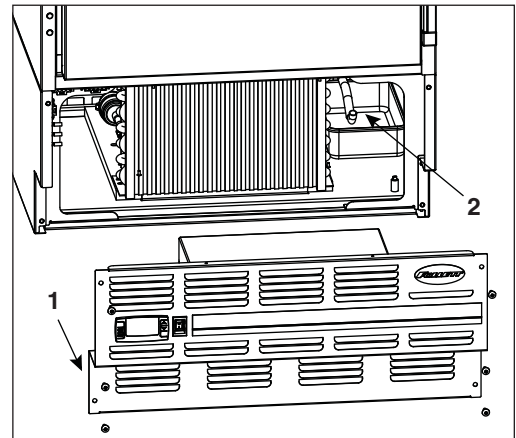

Service

Latch adjustment

To adjust for proper latch engagement

1. Loosen striker plate mounting screws (Fig. 7.1).
2. Move striker plate up or down as required and tighten screws.
3. Test operation of latch.

To adjust for proper gasket seal

1. Loosen striker depth adjustment screw (Fig. 7.2).
2. Adjust stop in or out and tighten screws.
3. Test operation of latch.

Fig. 7

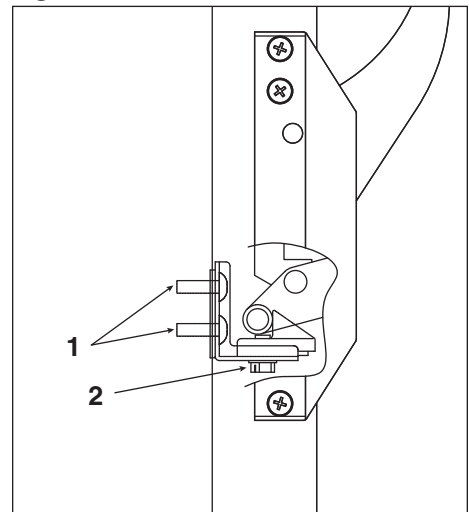

Door gasket replacement

1. Remove existing gasket from mounting track.
2. Verify mounting track is free of any remaining gasket material.
3. Align new gasket with mounting track and press firmly in place.
4. Open and close door, checking for proper gasket seal without pinching against freezer.
5. Adjust latch and or striker as necessary for proper door closure.

Slide-out compressor tray

Follett's slide-out compressor tray allows technicians to partially slide the condensing unit from the freezer back without cutting refrigerant lines.

1. Remove rear panel (Fig. 8.1).
2. Remove two bolts securing condensing unit to freezer base (Fig. 8.2).
3. Gently slide condensing unit out (Fig. 8.3).

Note: Do not put undue strain on the refrigerant lines.

Fig. 8

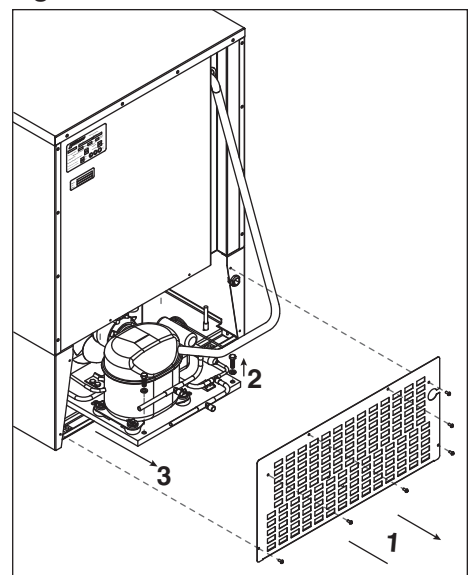

Removing drawers

1. Pull drawer forward to stop.
2. Lift drawer front to free front rollers from sides.
3. Still lifted, pull drawer forward to free back rollers from sides.

Removing slides

1. Push slides all the way back.
2. Swing bottom of slide away from refrigerator wall and lift slide off of rollers.

Controller replacement

1. Disconnect power to unit.
 - a. Push front panel rocker switch to OFF position.
 - b. Disconnect power cord.
2. Remove 6 screws from front panel and slide panel forward to access back of controller.
3. Disconnect front panel and wiring harness from freezer at the 3, 4, and 5 pin connectors and door heater to simplify replacement.
4. Push in on center of side brackets (on controller) to release and slide brackets back and off controller.
5. Push controller and wires out through front of front panel.
6. Using wiring schematic (attached to front panel and below) as a guide, remove wires one at a time from back of existing controller and connect to corresponding terminals on replacement controller.
7. Insert replacement controller back through front of panel.
8. Slide brackets onto sides of controller and push against back of front panel.
9. Reconnect 3, 4, and 5 pin connectors of wiring harness to freezer.
10. Keeping wiring clear of condenser, replace front panel.
11. Restore power and test operation. Reprogram replacement controller if necessary.

Wiring diagram

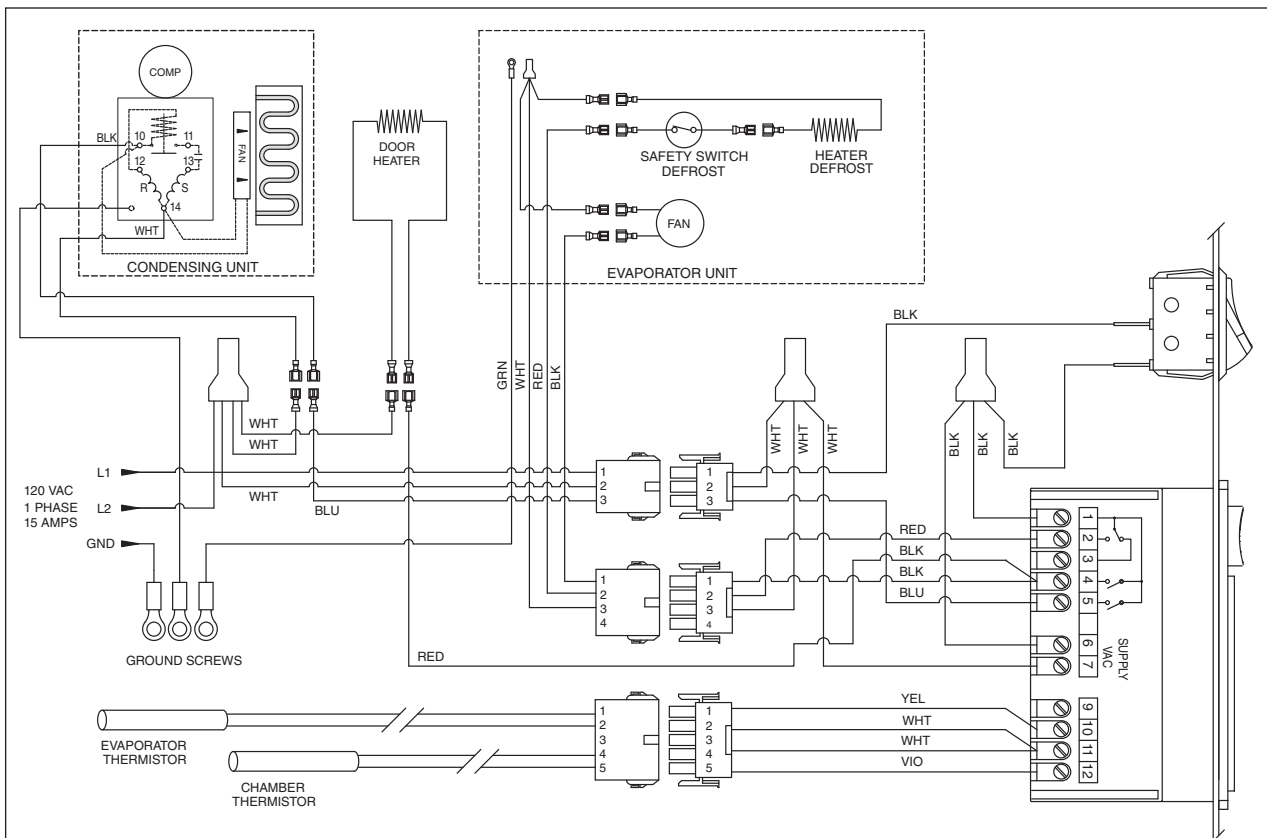

Refrigeration system

The FZR5-PL -30 C (-22 F) freezer refrigeration system is designed to give many years of trouble-free service. Except for routine cleaning of the air-cooled condenser and related parts, the refrigeration system requires no service or maintenance. The system uses a thermostatic expansion valve and is critically charged. Access fittings are provided for ease of service. However, the connection of refrigeration service hoses to the fittings will almost invariably result in a significant change in the system charge. This change can adversely affect the performance of your freezer. Therefore, Follett recommends that if hoses are ever connected to the refrigeration system for service, the refrigerant should be recovered, the system evacuated, and recharged by weighing in the correct refrigerant charge.

Note: Do not charge the system by pressures.

Checking refrigeration system pressures

1. Remove the rear access panel (Fig. 8).
2. Turn the power switch to the on position.
3. Following the instructions on page 5 verify that the temperature controller is set to the original factory set point cut out setting of -35 C (-31 F).
4. Allow the freezer to operate and stabilize at least 60 minutes, verifying the cut-out temperature is being reached.
5. Connect refrigerant hoses to access fittings and measure air temperature at condenser intake grille.
6. Verify correct pressures with the temperature chart below.
7. Troubleshoot refrigeration system as needed.

Condenser inlet air temperature	70 F	80 F
Discharge pressure (psi)	197	225
Suction pressure (psi)	4	5

Note: Do not attempt to obtain correct refrigeration pressures by adjusting the system charge.

Refrigeration system diagram

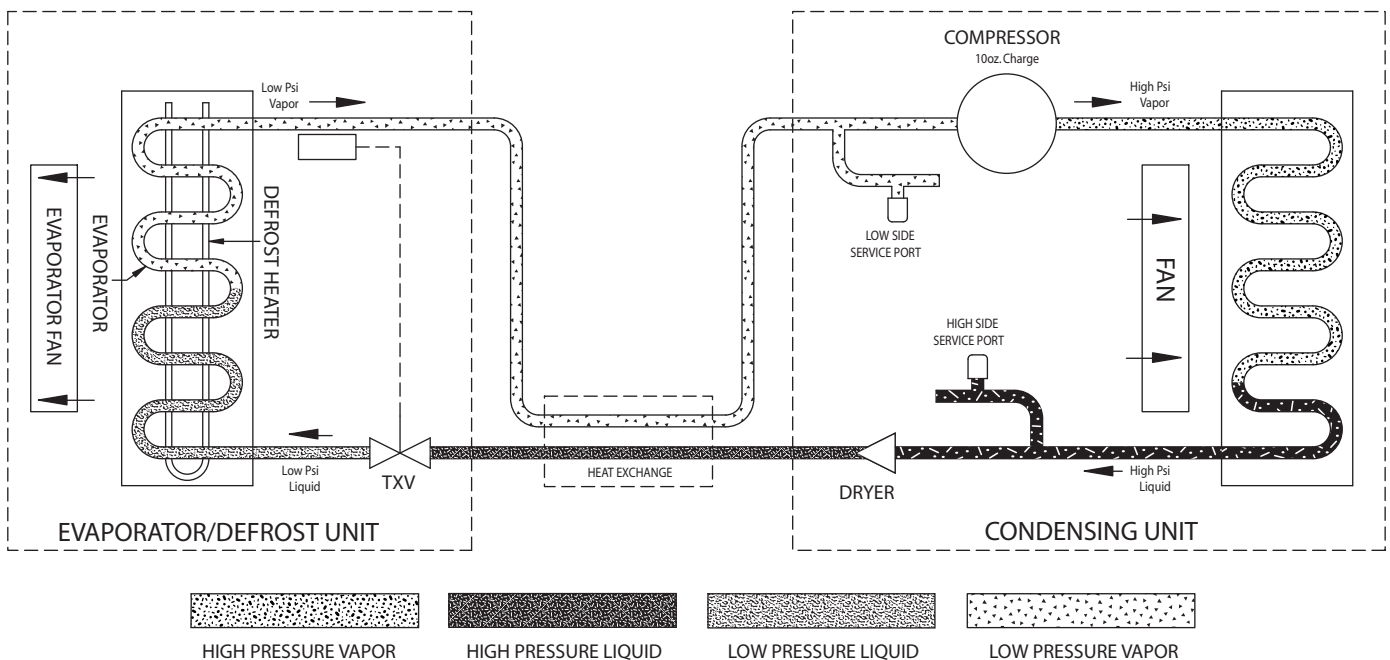

Freezer troubleshooting guide

Before calling for service

1. Check that unit is plugged in.
2. Test outlet with another appliance to verify power.

Symptom	Possible cause	Solution
Freezer does not operate (no components run).	<ol style="list-style-type: none"> 1. Power switch faulty or in OFF position; loose connection. 2. Freezer not plugged in. 3. No power to cord. 4. Temp controller not energizing components. 5. Probe not sensing cut in temperature. 	<ol style="list-style-type: none"> 1. Turn power switch to ON position; check switch and connections. 2. Connect plug. 3. Restore power. 4. Check controller contact terminals for power. Replace controller if needed. 5. Replace controller and/or probe.
Compressor does not run.	<ol style="list-style-type: none"> 1. Thermal overload open or defective. 2. Capacitor and/or relay defective. 3. Compressor defective. 	<ol style="list-style-type: none"> 1. Allow to cool or replace. 2. Replace as required. 3. Replace compressor.
Compressor and condenser fan do not run.	<ol style="list-style-type: none"> 1. No power on terminal 5 of controller (during cooling). 	<ol style="list-style-type: none"> 1. Replace controller
Evaporator fan motor does not run.	<ol style="list-style-type: none"> 1. No power on terminal 4 of controller (during cooling). 	<ol style="list-style-type: none"> 1. Replace controller.
Freezer does not shut off.	<ol style="list-style-type: none"> 1. Controller not sensing cut off temperature. 2. Controller keeping refrigeration system energized. 	<ol style="list-style-type: none"> 1. Replace controller and/or probe. 2. Replace controller.
Freezer does not maintain temperature (all components run).	<ol style="list-style-type: none"> 1. Condenser or evaporator coil needs cleaning. 2. Faulty door gasket. 3. Excessively high ambient. 4. Refrigerant leak. 5. Incorrect refrigerant charge. 6. Plugged expansion valve. 7. Inefficient compressor. 8. Evaporator coil blocked with ice. 	<ol style="list-style-type: none"> 1. Clean coils as needed. 2. Replace door gasket. 3. Maximum recommended ambient is 30 C (86 F). 4. Locate and repair leak. 5. Recover, evacuate and weigh in correct charge. 6. Replace expansion valve. 7. Consult technical service. 8. Depress defrost button on controller to defrost coil.
Evaporator does not defrost.	<ol style="list-style-type: none"> 1. Defective defrost heater. 2. Faulty heater safety switch. 3. No power on terminal 2 of controller (during defrost). 	<ol style="list-style-type: none"> 1. Replace defrost heater 2. Replace switch. 3. Replace controller.

If problems persist after following this basic troubleshooting guide, call Follett's technical service group at (800) 523-9361 or (610) 252-7301.

Replacement parts

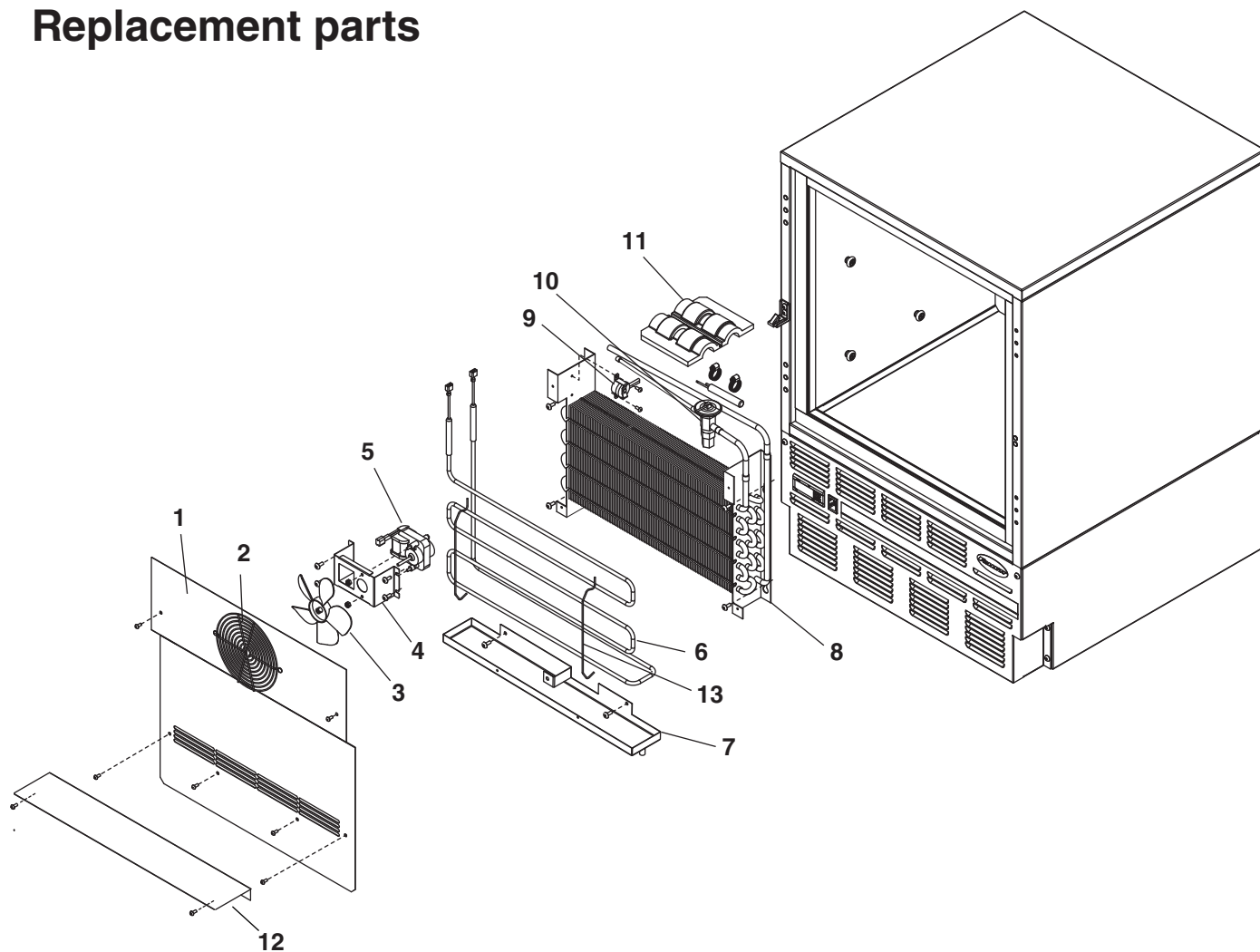

Evaporator

Reference #	Description	Part #
1	Cover, evaporator (includes 00152892)	00155564
2	Fan guard	00152892
3	Fan blade	00152991
4	Bracket, fan motor	00152983
5	Fan motor, evaporator	00104919
6	Defrost heater	00152645
7	Drain pan, evaporator, FZR5	00162511
8	Evaporator	00151563
9	Heater safety switch	00153932
10	Expansion valve (includes 00106534)	00155671
11	Insulation, bulb	00106534
12	Air baffle	00165126
13	Clips, defrost heater (2 needed)	00161554

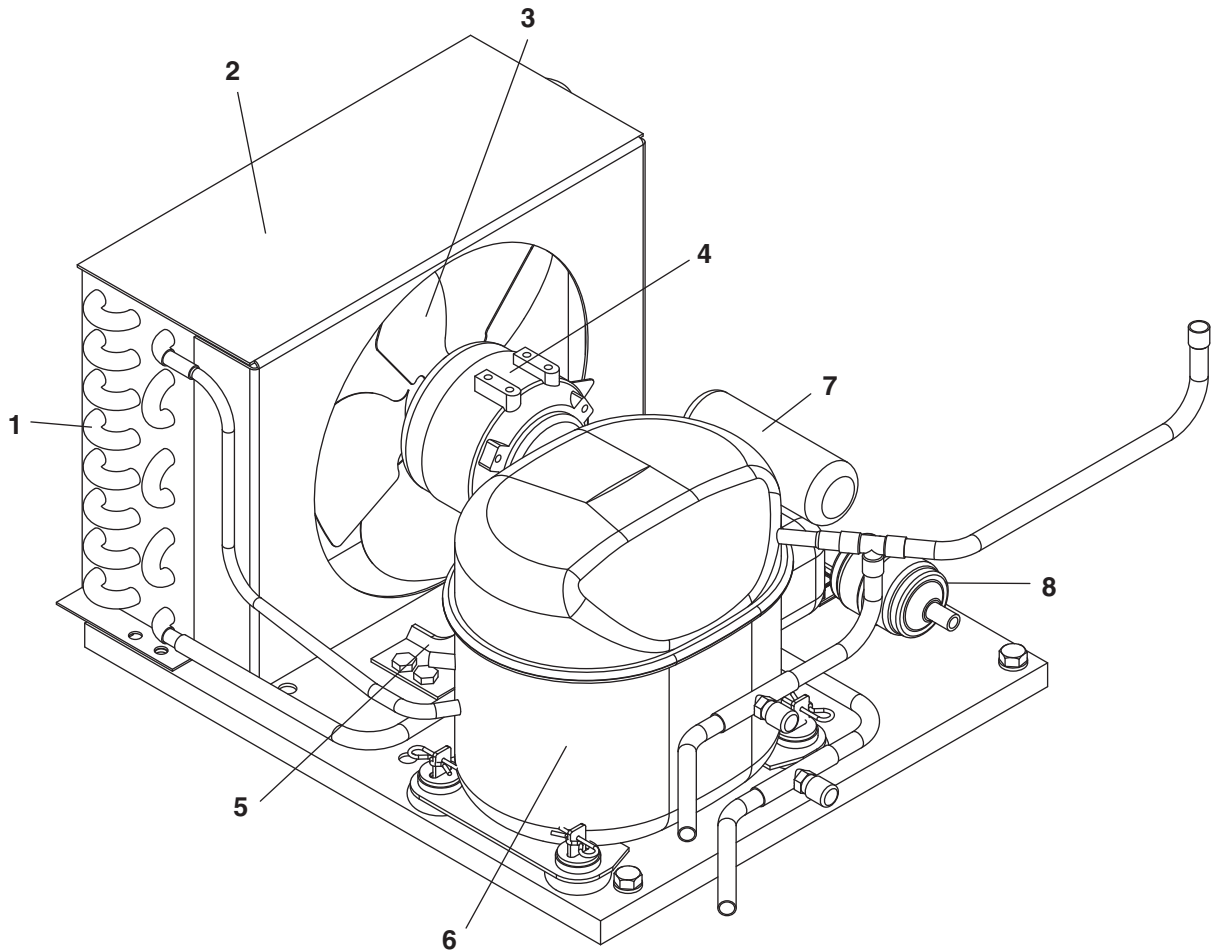

Condensing Unit

Reference #	Description	Part #
	Condensing unit	00153874
1	Condenser	00157339
2	Shroud, condenser	00157347
3	Condenser fan blade	00105007
4	Condenser fan motor	00104992
5	Fan motor bracket	00157412
6	Compressor	00157313
7	Starting capacitor	00104968
8	Filter drier	502724
Not shown	Cap, starting capacitor	00105627
Not shown	Starting relay	00157305
Not shown	Overload protector	00104984

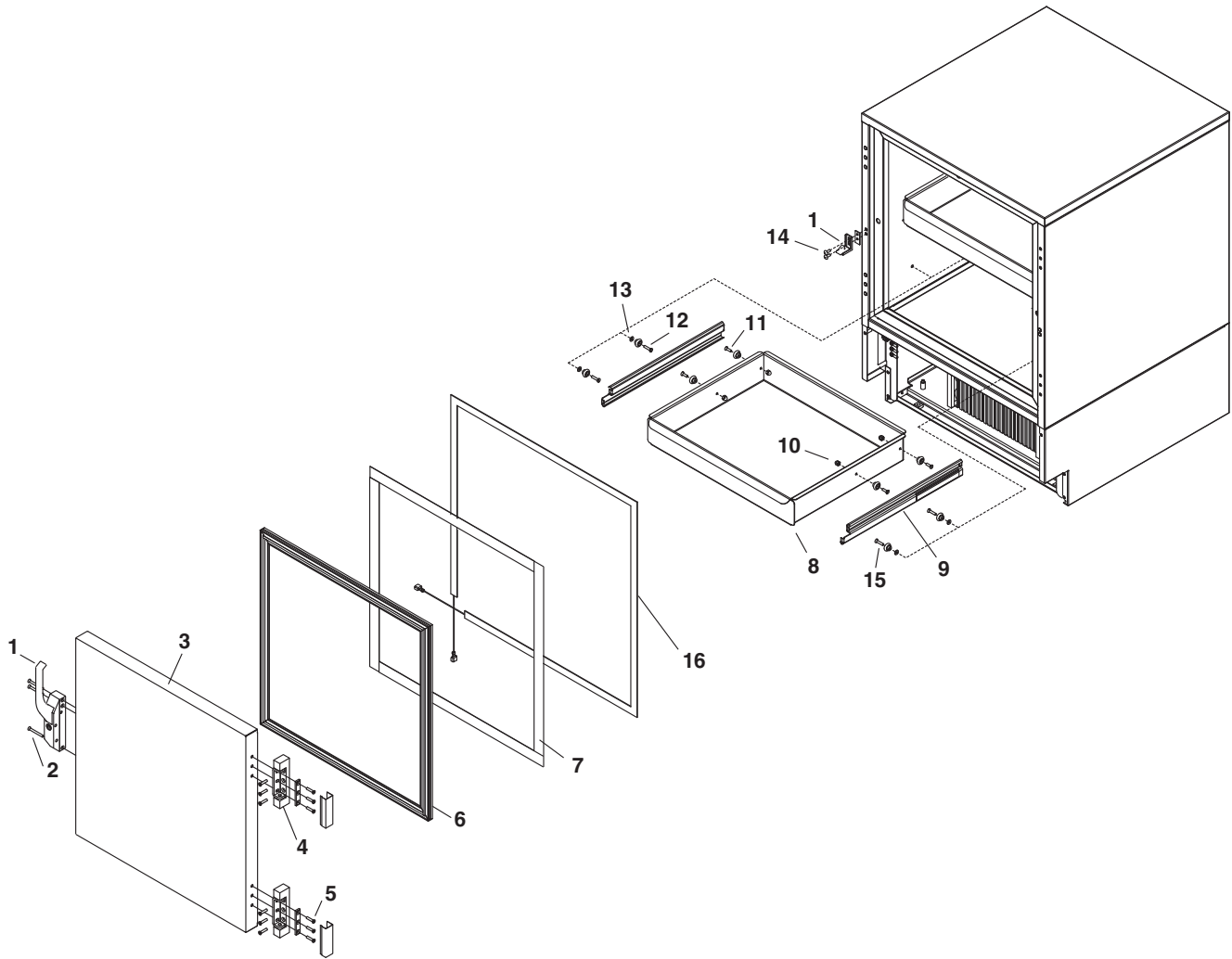

Hardware

Reference #	Description	Part #
1	Latch & striker includes screws	00105023
2	Latch screws, 3 per latch	00103507
3	Door (includes gasket - 21 3/8" x 21 3/8")	00105015
4	Hinge, each - 2 required, includes screws	00105031
5	Hinge screws, each - 6 per hinge	00105080
6	Gasket	00125732
7	Strip sealer (set of 4)	00130138
8	Drawer (includes 8 and 4 each of 10, 11 & 15)	00165134
9	Drawer slides (pair)	00161927
10	Nut, acorn, each (4 required per drawer)	00161802
11	Screw, 5/8", each (4 required per drawer)	200093
12	Screw, 7/8", each (4 required per drawer)	00161794
13	Washer, each (4 required per drawer)	00161786
Kit	Drawer & slide mounting hardware kit (includes 8, 9, 4 each of 10, 11, 12, 13 and 8 each of 15)	00165142
14	Striker screws, each - 2 per striker	502287
15	Bearing, roller	00167726
Kit	Slide & bearings (includes 9 (pair) and 4 each of 12, 13 & 15)	00167924
Kit	Bearings & screws kit (includes 8 each of 15 and 4 each of 10, 11, 12 & 13)	00167957
16	Door heater (includes 00130138)	00155531

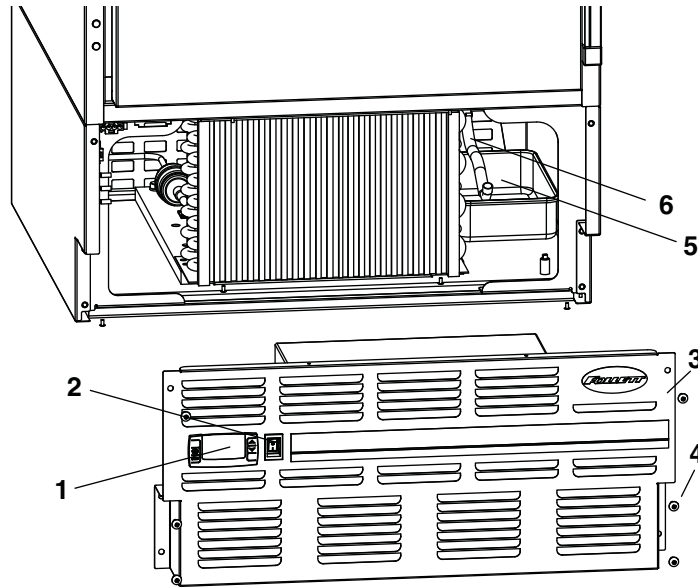

Hardware & electrical components

Reference #	Description	Part #
1	Temperature controller	00900118
Not shown	Temperature probe & harness	00155705
2	Power switch	00114371
3	Front panel (includes 00114371 and 00105379)	00173559
4	Front panel screws, each - 6 per panel	00105379
Not shown	Rear panel, includes screws	00130161
Not shown	Rear panel screws, each - 6 per panel	00105387
5	Condensate pan	00155622
6	Evaporator drain line, sold by the foot	203627
Not shown	FZR5-PL programming key, degrees C	00193391
Not shown	Power cord	00103903

Chart recorder related items

Reference #	Description	Part #
Not shown	Gasket, bottle	00171124
Not shown	Bracket, bottle	00171132
Not shown	Bottle	00171116
Not shown	Battery	00112177
Not shown	6" replacement, 7 day charts (quantity of 60)	00162099
Not shown	Replacement pens (quantity of 6)	00162081
Not shown	Probe, chart recorder	00162073