

McGunn Safe **Easy120**

SERVICE MANUAL

Specifications 2
Operation..... 3
Installation 4
Theory of Operation 5
Wiring Diagram..... 6
Troubleshooting 7
Door and Vend Delays 10
Repair 11
Parts List..... 16



EASY120 SPECIFICATIONS

Footprint — 32”H x 20”W x 20”D

Panel Depth — 5”

Weight — 270 lbs (approx., empty); 320 lbs (approx. ship)

Boltwork — 5 Point

Hinge — Continuous, heavy duty full length

Manual Drop — Drawer, 4.5” x 1.5”

Inner Compartment — Key locked

Tube Capacity — 120 Tubes (10 columns, 12 tubes/column); Internally loaded

Vend Mechanism — Solenoid activated release for hand operated knob cycle vending

Vend Delay — 2 Minutes default (adjustable by DIP switch 0 to 15 minutes)

Alt Vend — 30 Second Vend Delay (MGR key must be ON)

Door Delay — 10 Minute default (adjustable by DIP switch 0 to 15 minutes)

Armor Car Support — Key override of door delay for instant access

Keys — MGR, VEND, ACO (Armored Car), and Inner Compartment

EASY120 OPERATION

LOADING TUBES

- Open the outer door.
- Put rolled coin or bills into empty tubes.
- Insert full tubes into appropriate columns.
Stickers on the interior of the vend assembly indicate the number of tubes in each column. Tubes may be loaded with either end facing forward.

VENDING TUBES

- Insert the VEND key and turn to ON.
- Press the number button corresponding to the column you want to vend from.
- Rotate the release knob for the selected column.
- Collect your tube from the dispensing tray.
- The vend delay cycle must finish before you may vend again (the default delay is 2 minutes unless using the ALT VEND feature).

ALT-VEND FEATURE

Note: This procedure is used to enable a 30 second vend delay.

- Insert the MGR key and turn to ON.
- Press the ALT VEND button.
- The vend delay switches to 30 seconds.
- Press the ALT VEND button again to switch back to the normal vend delay.
- Switch the MGR key to OFF to disable the 30 second delay feature.

MANUAL DROPS

- Pull out the manual drop drawer.
- Insert drop envelope into drawer.
- Push manual drop in fully. *The drop envelope will fall into a secure inner compartment.*

OPENING THE OUTER DOOR

- Insert the MGR key and turn to ON.
- Press the DOOR button.
- The DELAY/READY indicator will turn red (this indicates a delay is in progress).
- The MGR key may be removed during the delay cycle if desired.
- At the end of delay cycle both indicators turn green.
- Insert the MGR key and turn to ON.
- Press the DOOR button.
- The DOOR indicator will turn off.
- IMMEDIATELY turn the handle and open the door.
- The door will automatically lock when you close the outer door.

ARMORED CAR ACCESS

- Insert and turn the ACO key.
- While holding the ACO key, IMMEDIATELY turn the handle and open the door.
- The door will automatically lock when you close the outer door.

OPENING THE INNER DOOR

- Open the outer door by normal or Armored Car procedure.
- Insert the inner door key into the inner door lock and turn.
- The inner door pulls down to allow access to the inner compartment.

EASY120 INSTALLATION

SITE PREPARATION

Before installing, make sure there is adequate clearance for the body and base of the safe as well as proper electrical power.

SPACE REQUIREMENTS

Space must be provided for mounting the safe, plus required clearance for access. A minimum gap of one inch must be provided on both sides and four inches at the rear of the safe. Clearance must be provided so that the safe door is allowed to swing open at least 90°.

- 1 Inch Side Clearance
- 4 Inches Rear Clearance
- 90° Door Swing Clearance
- Body Height Clearance

POWER REQUIREMENTS

A standard NEMA 15A 115V_{AC} grounded outlet must be provided within 6 feet of the hinge side of the safe. The unit may share its AC circuit with other point of sale electronic equipment, but must not be on the same circuit as rotating machinery such as a cooler or other refrigeration equipment.

- Standard 115V_{AC} Grounded Outlet
- No Rotating or Heavy Loads on AC Circuit
- Outlet Within Six Feet of Hinge Side

INSTALLATION PROCEDURE

Before proceeding, make sure the space and power requirements listed above are met for the mounting location. The safe is shipped with the outer door locked in the open position with rubber bumpers preventing accidental door closure.

REMOVE THE SAFE FROM THE PALLET

1. Remove wrapping material from the safe.
2. Remove the contents of the safe.
3. Unbolt the safe from the pallet.

VERIFY SAFE OPERATION

1. Locate the power supply unit packaged inside the unit. Unwrap the power supply.

2. Plug the power supply cable into the power supply jack at the rear of the safe.
3. Plug the standard grounded power plug into a standard 115V_{AC} outlet.
4. Wait for the display to stabilize (about 10 seconds).
5. Using the OPENING OUTER DOOR procedure (see Operating Instruction section), unlock the outer door.
6. Using the VENDING TUBES procedure (see Operating Instruction section), operate one column's vend knob as if a tube were present.
7. These steps verify operation of critical Easy120 features. **If the door or vending system cannot be operated, contact McGunn Technical Support immediately prior to bolting the safe down (1-800-452-4655).**

SAFE INSTALLATION

1. Obtain the anchor wedge kit from inside the safe and set aside.
2. Obtain the footprint template (shipped inside the safe).
3. Using a pencil, mark the mounting hole locations on the floor.
4. Drill four 1/2 inch holes to a depth of 3 inches. The holes must be clean. Use a vacuum to clean the holes. *Do not use water to clean the holes.*
5. Position the safe so that the bolt-holes align with the holes drilled in the floor. While doing so, feed the power supply cable and alarm cable through cabinet openings (if applicable) for routing access.
6. Drive each anchor wedge in until 1/4 inch to 1 inch of the top protrude through the floor of the safe.
8. Slide the washers down over each anchor wedge.
9. Put the nuts on each anchor wedge by hand until finger tight. Turn approximately three to four full turns by wrench to complete the tightening.

EASY120 THEORY OF OPERATION

MGR KEYSWITCH

This switch is a key controller switch that activates all Manager functions. Manager functions include enabling the ALT VEND function and opening the outer door. When the key switch is ON you may activate the ALT VEND function by simply pressing the ALT VEND button. You may also open the door by pressing the DOOR button while this key is ON. This key does not enable normal vending.

VEND KEYSWITCH

This switch is a key controlled switch that activates the vending feature. When this key is in the ON position, a user can vend tubes from the safe. Each time a tube is vended a delay must be satisfied before another tube may be vended. When this key is in the OFF position, no vending can take place on this system.

ACO KEYSWITCH

This switch is a key controlled momentary switch that allows an armored car carrier (or any other user that has this key) to immediately open the door by bypassing the door delay. When this key is activated, the door will immediately unlock, the DOOR LED will turn on, and you turn the handle to open the safe. There is a 30 second interval between periods this key can be used. So, if you turn the key and do not open the door, you have to wait 30 seconds to turn the key again.

DOOR LED

The DOOR LED on the display panel illuminates when either the ACO key has been activated or the door time delay has been reached and the door is ready to be opened. If a manager presses the DOOR button of the safe while the MGR key is in the ON position, the door delay will begin. Once this delay has been reached the DOOR LED will illuminate and the manager will have 10 minutes to come back to the safe and press the DOOR button to open the door. Once the door has been opened, or the 10 minutes period has expired, the DOOR LED will then turn off.

READY/WAIT LED

There is a Bi-Color (Red or Green) LED that serves as the READY or WAIT LED. Any time the system is in a delay, this LED will turn RED. When there is no delay in progress this LED will be GREEN. This LED also serves as a feedback for button presses. Since there is no buzzer on the system, each time a key is pressed this LED will blink an ORANGE color whether or not the LED was GREEN or RED before the button was pressed.

VEND BUTTONS 1-10

If the VEND Key is in the ON position, when a VEND button is pressed then (1) tube may be vended from the associated column. After the tube is vended, the system will then go into delay. The duration of the delay depends on a DIP switch setting (factory default is two minutes).

DOOR BUTTON

If the MGR key is in the ON position, when the door button is pressed the system will start the door delay (if a delay is set on the dip switch). After the delay has ended, when the door button is pressed within a 10 minute period while the MGR key is ON, the door will open.

ALT VEND BUTTON

If the MGR key is in the ON position, when this button is pressed the system will either have its normal vend delay or a 30 second vend delay (depending on which state it was in before the press, it alternates states). While the system is in the ALT VEND state, no matter what the dip switch delay is set to, the vend delay will immediately go to 30 seconds. It will continue in this state until either power is removed, or the ALT VEND mode is turned off.

ACCOUNTING

There is no accounting on the system. It does not track door or vending events. The system will, however, only allow one tube to vend per request.

EASY120 WIRING DIAGRAM

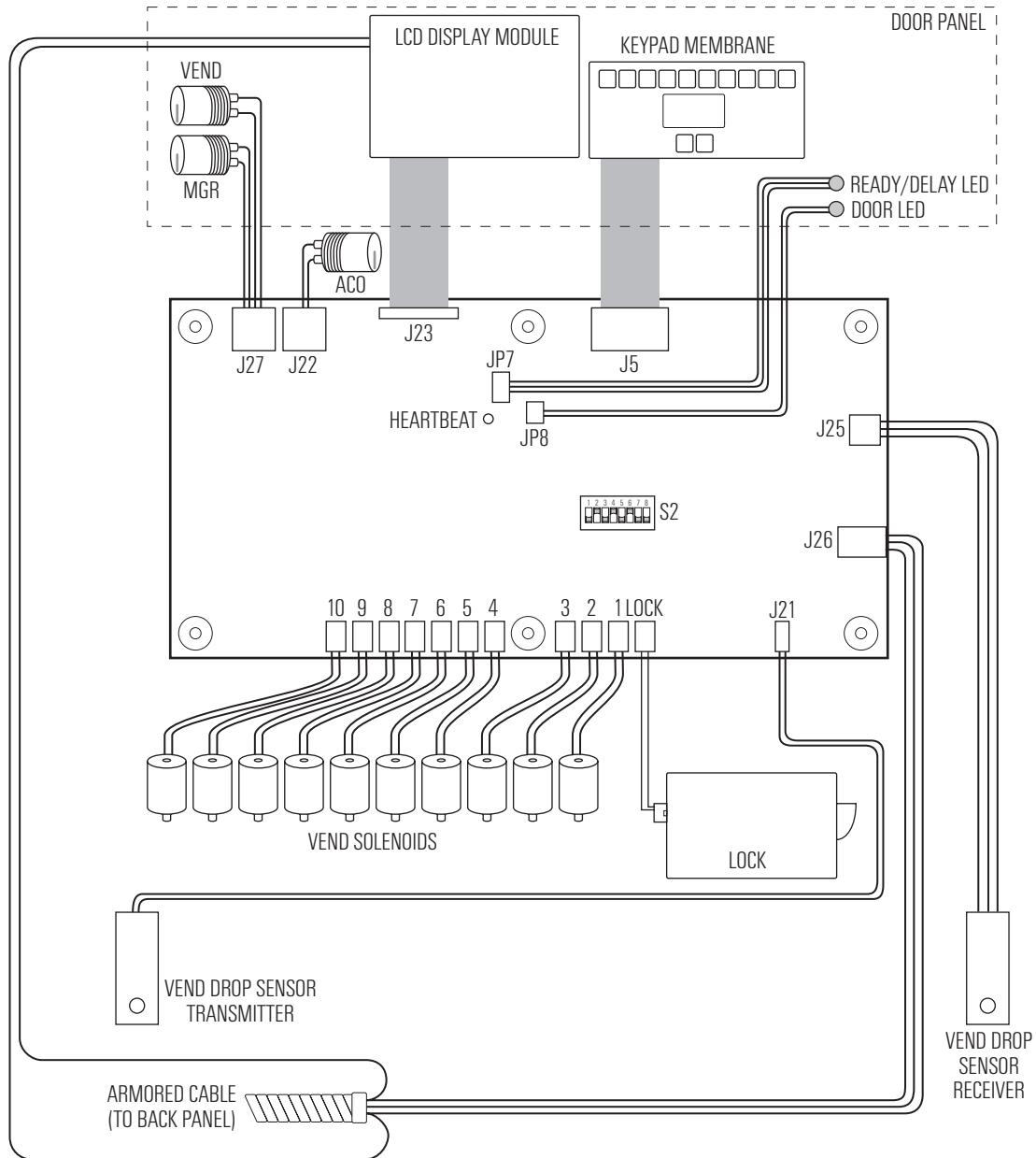

Easy120 Wiring Diagram

Armored Cable: Red, Blue, and Black to J26; Red and Black to LCD module.

Vend Key Switch: Orange wires to J27.

MGR Key Switch: White wires to J27.

ACO Key Switch: Red and black wires to J22.

LCD Module Data: Flat ribbon cable to J23.

Keypad Membrane: Flat ribbon cable to J5.

Ready/Delay LED: Red (top), black, white wires to JP7.

Door LED: Black (top) and white wires to JP8.

Vend Solenoids: Blue wire pairs to associated J7 connector.

Lock: Orange and Black (top two wires of RJ45 at lock) to J7 LOCK1 connector.

Vend Drop Sensor Transmitter: Yellow and Black wire harness to J21.

Vend Drop Sensor Receiver: Yellow, Black, and Yellow wire harness to J25.

EASY120 TROUBLESHOOTING

INTRODUCTION

Most problems will fall into one of these categories: mechanical/door operation, vending, power, or electronics. If you can successfully determine the nature of the problem you can greatly reduce the number of possible causes.

POWER

If the unit has no power, the display will be off, both LEDs will be off, and there will be no response from the keypad.

EXTERNAL POWER

The unit is powered by an external DC power supply (Part 15000346). Measure the output voltage to determine power supply operation up to the back of the safe (only $+12 V_{DC}$ and $+5 V_{DC}$ and common are used). If the problem is external verify the outlet has power and replace the power supply if faulty. If the power supply output is good and everything is connected properly, the problem is inside the safe.

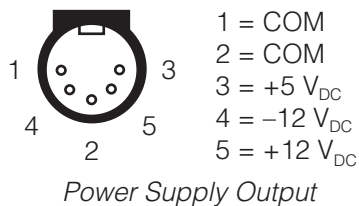

INTERNAL POWER

Possible problems include the cable harness, the LCD display module, or the main board.

Internally power runs on two sets of wires from the rear of the safe through an armored cable to the door.

Inside the back of the safe: two black wires carry power common from Pin 1 of the jack to J26 (main board) and the LCD module. A blue wire carries $+12 V_{DC}$ from Pin 3 on the jack to J26 on the main board. Two red wires carry $+5 V_{DC}$ from Pin 5 of the jack to the LCD module and main board J26.

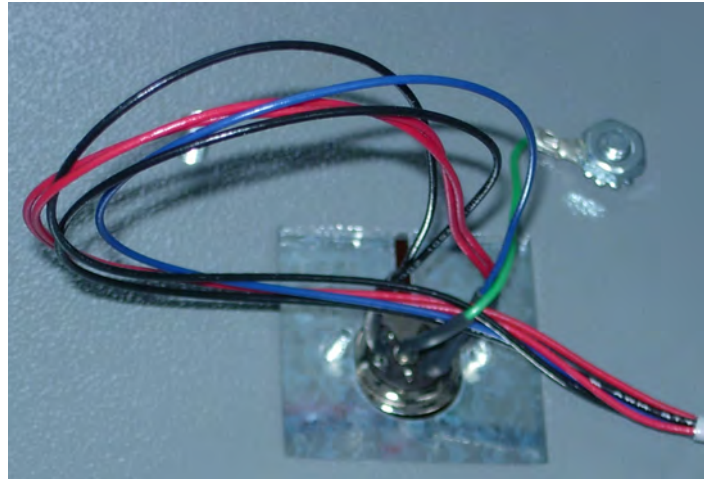

Power Supply Jack Wiring at Rear Inside of Safe

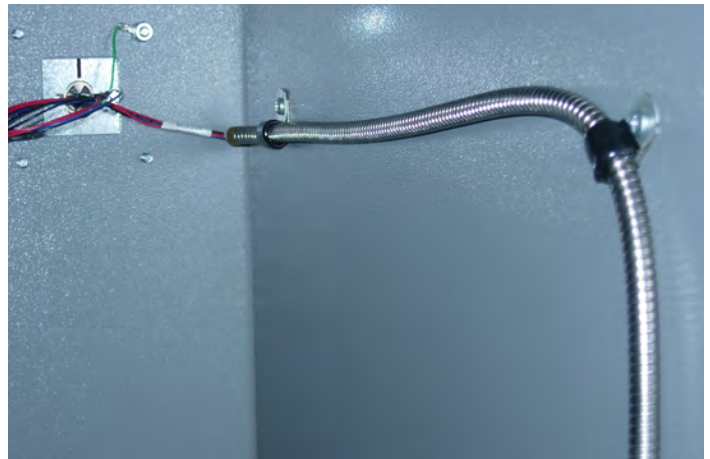

Armored Cable Routing

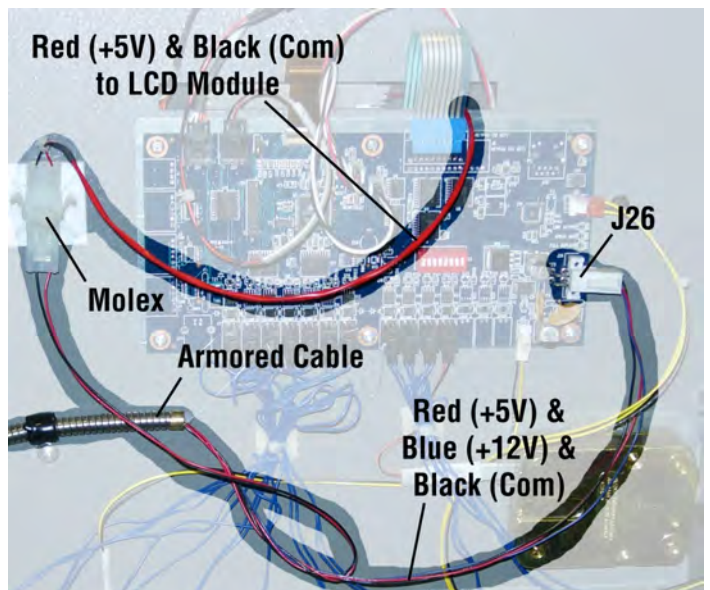

*Power Wires from Armored Cable
To: J26 at Main Board
To: LCD Module via Molex Connector*

Disconnect J26 and the molex connector to the LCD panel and check for correct voltages at each plug (blue = +12 V_{DC} and red = +5 V_{DC} relative to black). If the armored cable is okay, the problem is either the LCD module or the main board. Plug J26 in and see if the Heartbeat LED on the main board blinks. If not, the problem is definitely the main board. If the Heartbeat indicator does blink, the problem is more likely to be the LCD module.

VENDING

Vending problems may include an empty column, a tube jam, a solenoid problem, a vend drop sensor problem, or an electronics problem.

TUBE JAM OR EMPTY COLUMN

Open the door and visually inspect to make sure there are tubes in the column and there is no jam. If the column is jammed clear the jam.

SOLENOID OR MAIN BOARD

While attempting to vend from the problem column, verify the solenoid energizes (pin pulls up) when the screen indicates it should. If the solenoid does not, check the connection to the main board. Check the voltage to the solenoid at the main board connection while attempting to vend to determine if the problem is the solenoid or the main board.

VEND DROP SENSOR

If the safe vends properly but the tube count does not decrement or if the solenoid remains energized even after you physically vend a tube there is a problem with the vend drop sensor. Check the physical mounting of the vend drop sensor transmitter and receiver boards and check for any obstructions of the beam across the tray area. Check electrical connections at sensor boards (transmitter on hinge side, receiver on open side) and main board J21 and J25. Check continuity of sensor cables. Replace both boards only if no other problem is found.

VEND KEY SWITCH

If the vend key switch or its wires fail, the keypad will not respond to any attempts to vend even though the display will work and the door will still operate.

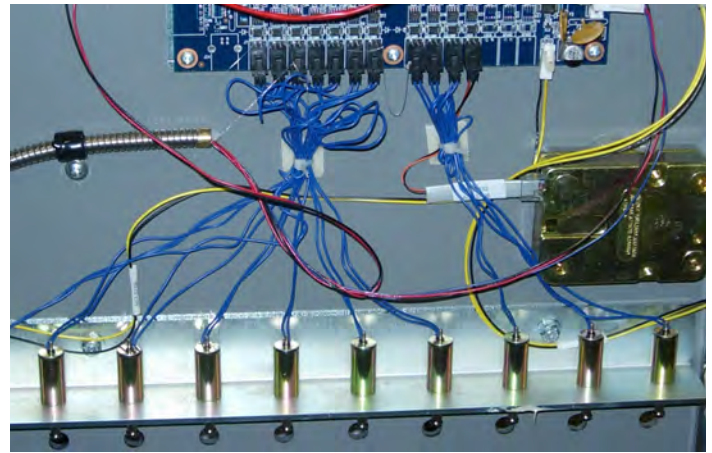

Blue Wire Pairs from Solenoids to Main Board



Vend Drop Sensor (Receiver Side Shown)



*Keypad Membrane
MGR Key Switch (far right)
VEND Key Switch (to the left)*

KEYPAD

If the keypad membrane is damaged one or more columns may not respond when you attempt to vend.

OUTER DOOR

Possible outer door problems preventing operation may include handle/cam failure, stuck or blocked bolt work, lock failure, main board failure, key switch failure, or a wiring problem with a switch or the lock.

MECHANICAL

Pressure on the inside of the door from items stuffed inside can make it very difficult to open the door. The best solution if this happens is to apply pressure to the front of the door while turning the handle. Damaged or jammed bushings can cause similar symptoms. If the handle cam is loose the handle will turn without moving the bolt work.



Handle Shaft with Cam (left) and a Guide Bushing (right)

ELECTRICAL

Using the normal door procedure attempt to open the door. If nothing happens when you press the DOOR button, the problem is the keypad. If both LEDs turn green at the end of the delay but the DOOR LED does not go off when you turn the MGR key, the problem is the MGR keyswitch. If either of the above are the problem, the ACO key should still be able to open the door. If the LEDs respond properly to the MGR keyswitch yet you cannot open the door using the Normal or Armored Car Door Procedure the problem is probably either a lock failure or lock cable.

MAIN ELECTRONICS

The main board is the heart of the Easy120. Component failure on the main board can manifest in any number of ways ranging from intermittent door or vending problems to complete display failure, garbled display, inability to count tubes, or otherwise failure to properly respond. The main board constantly checks itself as evidenced by a flash of the Heartbeat LED about once per second. If the Heartbeat LED does not blink the main board should be replaced.

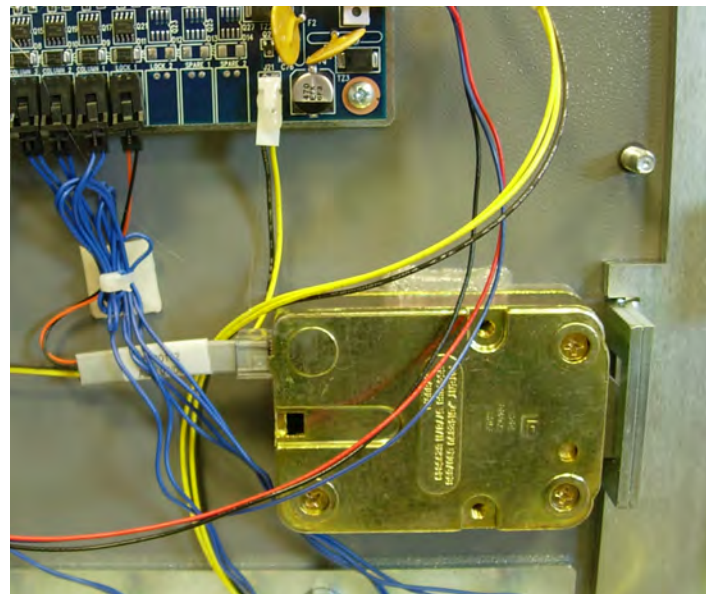

Outer Door Lock

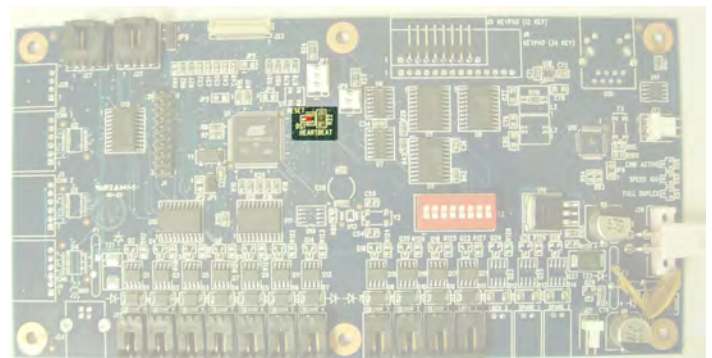

Main Board (Heartbeat LED Highlighted)

EASY120 DOOR AND VEND DELAYS

CONFIGURING DELAYS

On the main circuit board you will find an eight segment DIP switch marked S2. This DIP switch is used to adjust the DOOR DELAY and VEND DELAY values.



S2 DIP Switch Sets Door and Vend Delays

DEFAULT SETTING

By factory default it is configured with segments 2, 4, and 6 ON and all other segments OFF. This combination sets a 10 minute DOOR DELAY with a 2 minute VEND DELAY.

CUSTOM SETTING

Delays are in units of minutes. With power off change the DIP switches to obtain the desired delay values. Turn power on and the electronics will recognize the new delay settings.

DIP Switch Segments				DOOR DELAY
1	2	3	4	
OFF	OFF	OFF	OFF	None
ON	OFF	OFF	OFF	1 Minute
OFF	ON	OFF	OFF	2 Minutes
ON	ON	OFF	OFF	3 Minutes
OFF	OFF	ON	OFF	4 Minutes
ON	OFF	ON	OFF	5 Minutes
OFF	ON	ON	OFF	6 Minutes
ON	ON	ON	OFF	7 Minutes
OFF	OFF	OFF	ON	8 Minutes
ON	OFF	OFF	ON	9 Minutes
OFF	ON	OFF	ON	10 Minutes
ON	ON	OFF	ON	11 Minutes
OFF	OFF	ON	ON	12 Minutes
ON	OFF	ON	ON	13 Minutes
OFF	ON	ON	ON	14 Minutes
ON	ON	ON	ON	15 Minutes

S2 Segments 1 to 4 Set Door Delay

DIP Switch Segments				VEND DELAY
5	6	7	8	
OFF	OFF	OFF	OFF	30 Seconds
ON	OFF	OFF	OFF	1 Minute
OFF	ON	OFF	OFF	2 Minutes
ON	ON	OFF	OFF	3 Minutes
OFF	OFF	ON	OFF	4 Minutes
ON	OFF	ON	OFF	5 Minutes
OFF	ON	ON	OFF	6 Minutes
ON	ON	ON	OFF	7 Minutes
OFF	OFF	OFF	ON	8 Minutes
ON	OFF	OFF	ON	9 Minutes
OFF	ON	OFF	ON	10 Minutes
ON	ON	OFF	ON	11 Minutes
OFF	OFF	ON	ON	12 Minutes
ON	OFF	ON	ON	13 Minutes
OFF	ON	ON	ON	14 Minutes
ON	ON	ON	ON	15 Minutes

S2 Segments 5 to 8 Set Vend Delay

EASY120 REPAIR

WARNINGS

- **ONLY FACTORY AUTHORIZED SAFE TECHNICIANS SHOULD ATTEMPT TO SERVICE THE EASY120 SAFE.**
- **PROCEDURES AND TOOLS REQUIRED TO DRILL OPEN THE SAFE ARE NOT IN THIS DOCUMENT. AUTHORIZED TECHNICIANS WILL BE PROVIDED WITH THE INFORMATION REQUIRED DIRECTLY FROM THE FACTORY.**
- **UNAUTHORIZED SERVICE WILL VOID THE WARRANTY AND MAY RESULT IN ADDITIONAL DAMAGE.**
- **REMOVE POWER BY UNPLUGGING THE EXTERNAL POWER SUPPLY BEFORE CONNECTING OR DISCONNECTING ANY ELECTRICAL COMPONENTS INSIDE THE SAFE.**
- **USE ANTI-STATIC PROTECTION AT ALL TIMES WHEN HANDLING ELECTRONIC CIRCUIT BOARDS AND COMPONENTS.**

TOOLS

Most repairs to the Easy120 safe require only common tools. The T-25 Security Torx bit is only required for accessing the front panel. Be sure to use a grounding strap any time you are handling any circuit boards. Standard service tools for the Easy120 should include the following:

- Phillips Screwdriver
- 3/8" Nut Driver / Wrench
- 7/16" Nut Driver / Wrench
- 1/2" Nut Driver / Wrench
- T-25 Torx Security Bit
- Pliers
- Multi-Meter
- Grounding Anti-Static Strap

REPLACEMENT PARTS

Always obtain all replacement parts from the factory. Using non-factory parts will void the warranty and may damage your safe.

VEND ASSEMBLY

The Vend Assembly must be removed in order to access most of the electrical and electronic components on the inside of the door.

To REMOVE THE VEND ASSEMBLY:

1. Pull off all ten of the vend knobs from the front.



Vend Knobs Slide Off and On

2. Remove the Vend Drop Sensor Boards. To remove the boards use a phillips screw driver and remove the two mounting screws from each board.



Disconnect Drop Sensor Boards (ex. shown left) or Remove Drop Sensor Boards (ex. shown right)

- Using a 7/16" hex nut driver or wrench remove the six nuts (two on the right, four on the left) holding the metal Vend Assembly to the door. Gently slide the entire assembly back and set it out of the way.

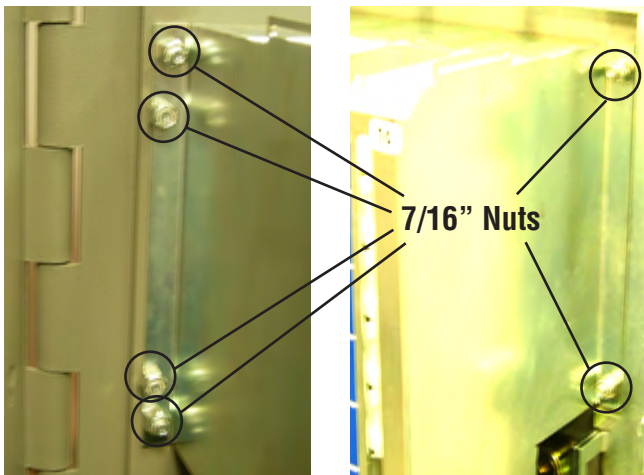

7/16" Capture Nuts:
4 Hinge Side (shown left) and 2 Open Side (shown right)

CASTING REPAIR

To repair any part of the casting assembly remove all tubes and turn the vend assembly upside down. Back off the set screw for the casting to service. Slide out the casting spindle. Pull the front of the casting free, then the front and rear casting bushing will come loose. Replace damaged parts and reverse process to reinstall.



L to R: Rear Bushing, Casting, Front Bushing, Spindle

TO REINSTALL THE VEND ASSEMBLY:

Reverse the above steps. Be sure the notches in all of the vend casting spindles are facing up. Be careful to avoid pinching any wires when mounting the assembly.



Casting Spindle Notches Facing Up



Avoid Pinched Wires (ACO Key Switch Wire)

UNDER THE VEND ASSEMBLY

The vend assembly must be removed in order to access and replace the main circuit board and all other electronics in this section.

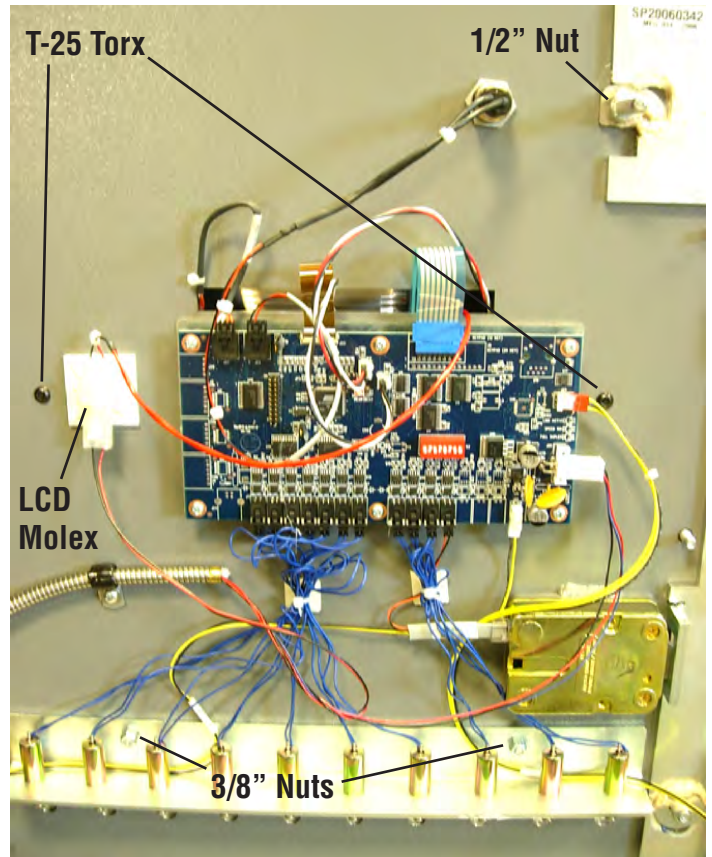

Vend Assembly Must Be Removed to Access Most Electronic Components Including Outer Door Panel Items

MAIN BOARD

Use a grounding strap to avoid static damage any time you handle the main circuit board. Remove power by unplugging the external power supply before replacing the main circuit board. When replacing the main board be sure to carefully note where each plug goes so you put them in the correct jacks with the correct orientation on the new board. Be sure to set the DIP switch (S2) correctly and make sure jumper JP1 is installed

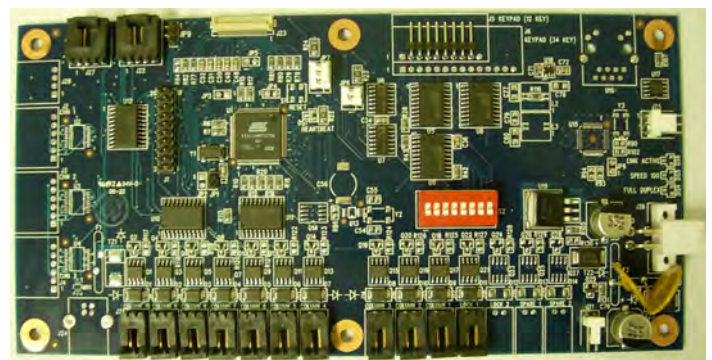

New Main Board

and jumper JP9 is installed between its two lower pins on the replacement board. You may need to transfer the jumpers from the old board to the new board. Six phillips screws hold the main circuit board to the door.

Lock

The lock is mounted on a layer of hard plate with phillips head screws. It connects to the door via a short cable (orange and black wires only). The cable has an RJ45 connector at the lock and a snap-on plug for the LOCK1 jack at main board.

SOLENOIDS

Each solenoid is held to the bracket by its nut. To replace a solenoid first remove the bracket and cover assembly. Care must be taken to avoid twisting and thus damaging the solenoid wires while removing solenoid nuts. Solenoid wires must be routed through the bracket cover openings close to the door. The bracket cover prevents anything from weighing down the solenoid pins. Care must also be taken to ensure each solenoid cable is connected to the corresponding column connector on the J7 jack set.

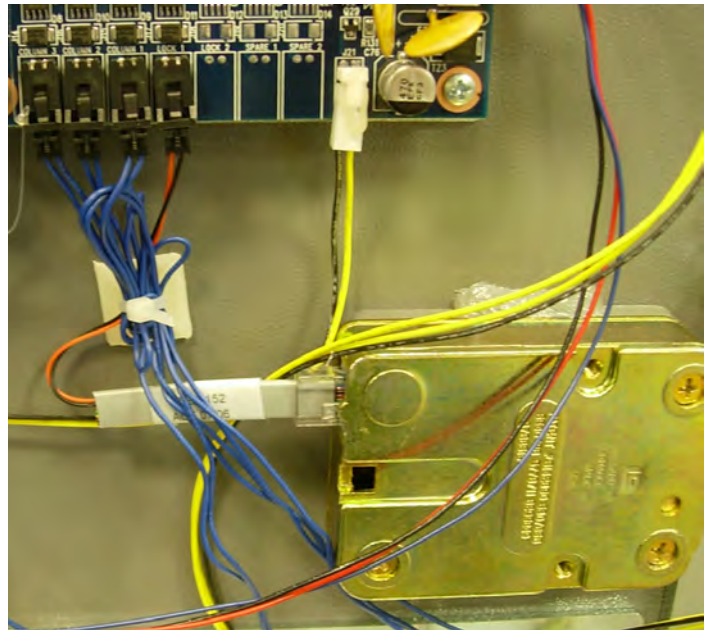
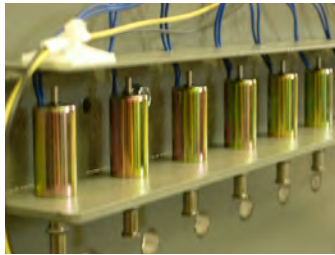

Lock Connected to Main Board

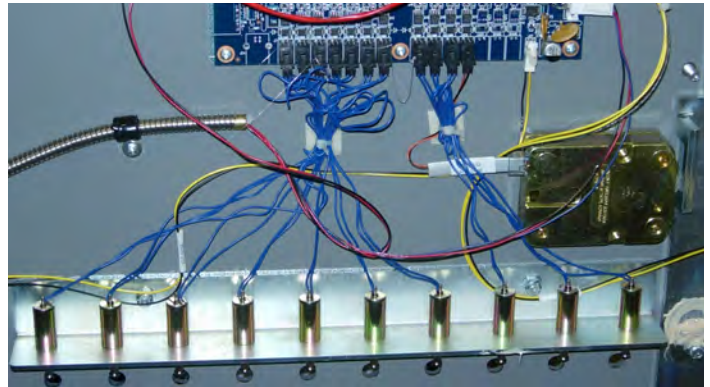

Solenoids Connect to J7 Jacks (bracket cover not shown)

VEND DROP SENSOR BOARDS

The Receiver module is the one on the open side. It has a three-pin jack and is electrically connected to J25 on the main board. The Transmitter module is mounted on the hinge side. It has a two-pin jack and is electrically connected to J21 on the main board.

ACO KEY SWITCH

The ACO Key Switch is mounted directly to the door, above the front panel and across from the handle. It is electrically connected to J22 on the main board.

FRONT PANEL

The front panel must be removed to access and replace the VEND and MGR key switches, the DOOR LED, the READY/WAIT LED, LCD module, or keypad membrane.



ACO Key Switch from Interior (left) and Exterior (right)

To Remove the Front Panel:

1. Disconnect the following main board items: J27 (to key switches), J23 (to LCD module), J5 (to keypad membrane), JP7 (to READY/WAIT LED), JP8 (to DOOR LED).
2. Disconnect the power supply moxex to the LCD module.
3. Remove the T-25 Torx Security Head screws holding the front panel to the door. Be careful to avoid damaging wires routed through the door.

KEYPAD MEMBRANE

The keypad itself is a flexible membrane. It sticks to the front panel with self-adhesive. To replace this membrane:

1. Remove the front panel.
2. Peel back the membrane and remove completely.
3. Remove the adhesive cover from the new membrane.
4. Carefully route the keypad ribbon before allowing adhesive surface to stick to panel.
5. Carefully position the membrane and stick the adhesive surface to the panel.

LCD MODULE

The LCD module is mounted under the front panel. The ribbon cable to J23 and the portion of the power supply wire harness from the LCD Molex to the LCD module are part of the LCD module assembly. To replace the LCD module simply remove the front panel and remove the four phillips head screws holding the LCD module to the underside of the front panel.

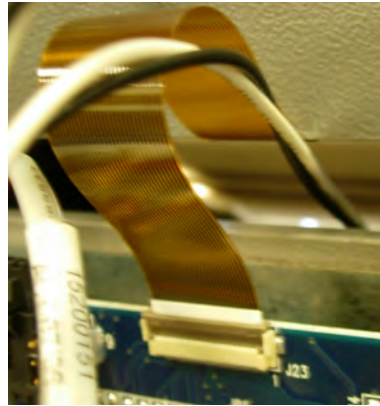

*LCD Ribbon Cable Connection to J23 (left)
Power Input to LCD Module (right)*

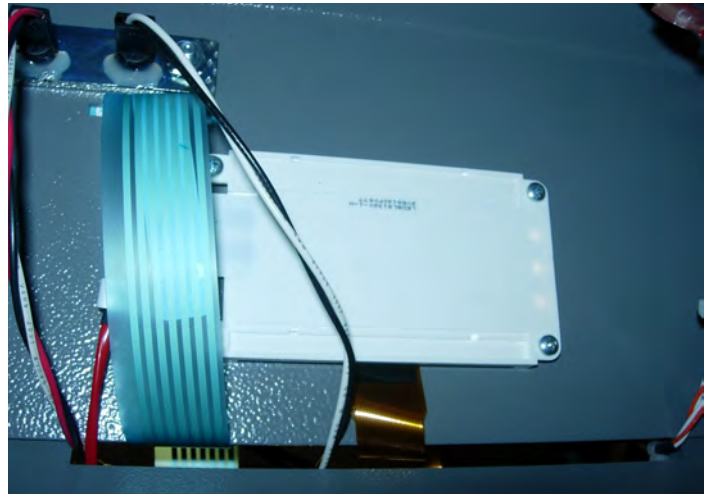

LCD Module Mounting Inside Front Panel



Front Panel Exterior View

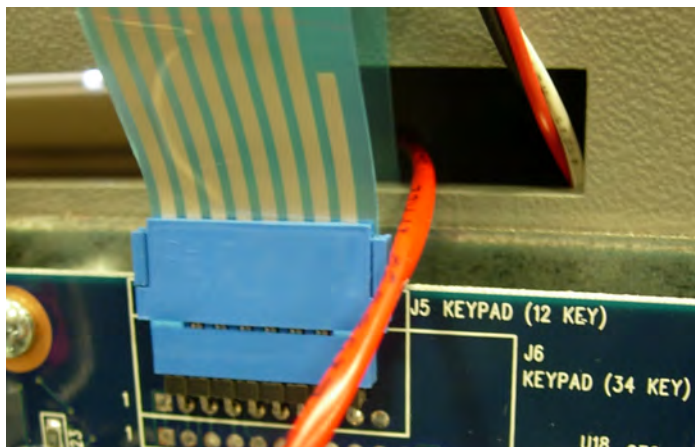

Keypad Ribbon Cable Connection to J5

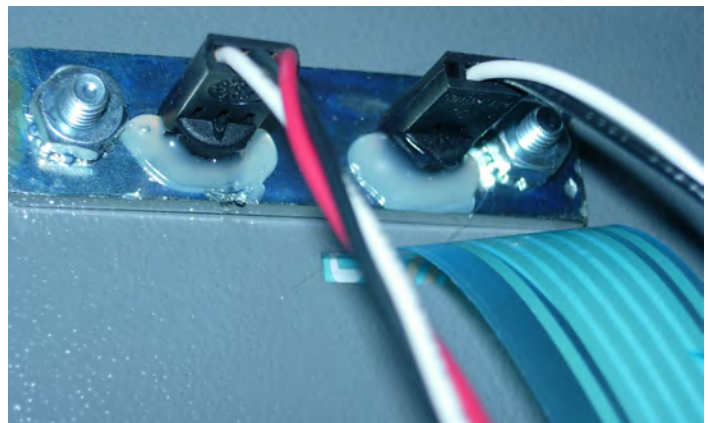

READY/WAIT (left) and DOOR (right) LEDs

VEND AND DOOR KEY SWITCHES

The VEND and DOOR key switches are slotted to ensure proper orientation and they are held on with hex nuts. The J27 wire harness includes a pair of orange wires and a pair of white wires. Each wire is terminated with spade connectors. Connect the orange wires to the MGR keyswitch (closest to the side wall). Connect the white wires to the VEND key switch.

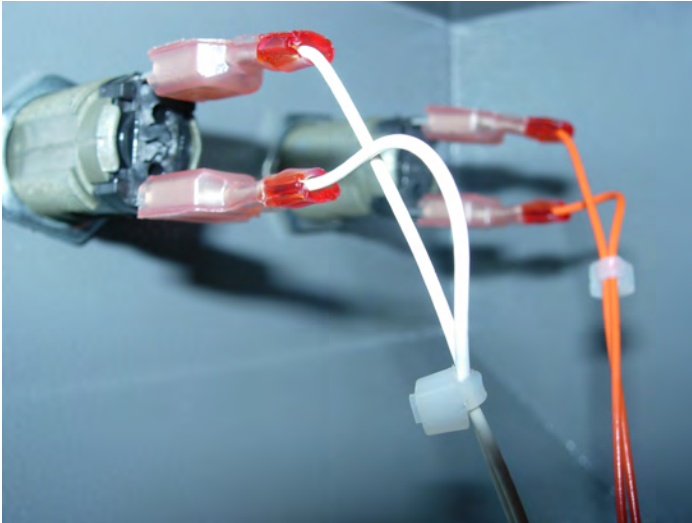

Keypad Ribbon Cable Connection to J5

BOLT WORK

The T-Handle spindle is fitted through a stand-off on the face of the door. On the inside the cam is anchored by a 9/16" locknut. When the handle turns the cam drives the solid piece bolt work up on its guides. 1/2" capture nuts hold the bushings in place which in turn hold the bolt work piece flush against the door. All moving parts are greased to ensure smooth operation.



Assembled Bolt Guide



*Top C: Handle Spindle with Cam & Locknut
Bottom L to R: Guide Flatwasher, Nylon Washer, Bushing*

INNER COMPARTMENT LOCK

The lock to the inner compartment is a simple 1/4 turn key lock. The inner compartment door is attached by a simple hinge and swings down for access to manual drops.

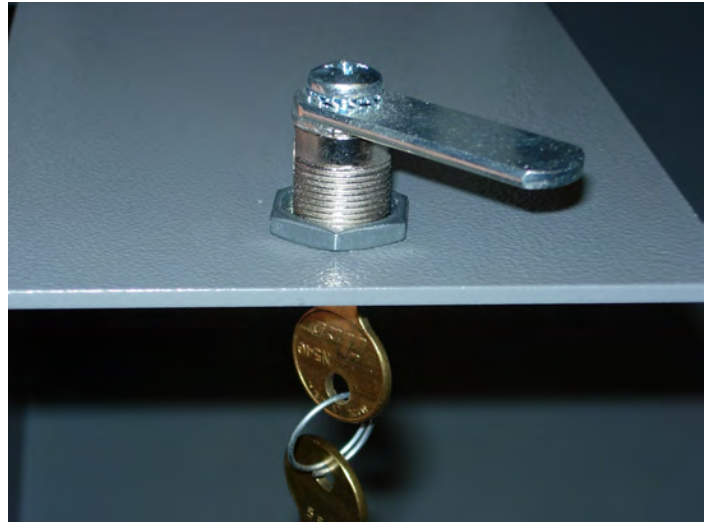

Inner Compartment Key Lock

MANUAL DROP DRAWER

The manual drop drawer includes an anti-phish baffle and steel back stop. The drawer can be replaced by removing the dual nuts holding the back stop piece to the rear of the drawer.



Manual Drop Drawer Back Stop

EASY120 PARTS LIST

ELECTRONICS

15200100 Easy120 Main Board
15000346 External Power Supply
15200153 Armored Power Harness
15200157 Spring-loaded Keyswitch: ACO
15200151 Single Key Switch Cable (J22)
800316 Keyswitch (2): VEND & MGR
15200150 Dual Key Switch Cable (J27)
801061 Keypad Touch Membrane
15200154 LCD with Harness
15008102 LED, Ready/Wait Bicolor Red/Green
15000389 LED Cable, Ready/Wait (JP7)
15008004 LED, Door Green
15000390 LED Cable, Door (JP8)
15000391 LED Lens (2)
15016000 Outer Door Lock
15200152 Lock Cable
15200200 Drop Transmitter Board
15200251 Drop Transmitter Cable (J21)
15200201 Drop Receiver Board
15200250 Drop Receiver Cable (J25)
801150 Solenoid, w/ nut and wires (10)

VENDING HARDWARE

701326 Solenoid Mounting Bracket
701428 Solenoid Cover
801189 Solenoid Lock Washer (10)
800303 Drop Module Screw 7/16 6-32 (4)
600883 Vend Assembly Chassis
801057 Vend Casting (10)
801160 Vend Casting Set Screw (10)
801062 Vend Casting Rear Bushing (10)
801063 Vend Casting Front Bushing (10)
801058 Vend Casting Spindle (10)
801084 Vend Knob (10)

INTERIOR HARDWARE

600884 Inner Door
701315 Inner Door Hinge Assembly
801109 Key Lock, Inner Door
600823 Manual Drop Drawer (w/ back stop parts)
GN-4014 Drawer Back Stop
GN-1028 Bolt, Drawer Back Stop
G-3223 Locknut, Back Stop 9/16" Hex, 3/8-16 (2)
800215 Cable Clamp 5/16 (4)
701334 Rear Connector Plate
801094 Connector Plate Screws (4)

DOOR HARDWARE

3914 T-Handle
701327 Handle Spacer
701328 Handle Cam
G-3223 Locknut, Handle 9/16" Hex, 3/8-16
600828 Bolt, One-Piece
701323 Bolt Guide Bushing (3)
801096 Bolt Nylon Washer (3)
801097 Bolt Flat Washer (3)
G-3154 Bolt Locknut 1/2" Hex, 5/16-32 (3)
701362 Hinge Assembly
G-3222 Locknut, Hinge 7/16" Hex, 1/4-20 (8)
600827 Drop Tray
701319 Drop Tray Support Bracket
G-3222 Locknut, Brkt/Body 7/16" Hex, 1/4-20 (2)
801093 Locknut, Brkt/Tray 10-32 (2)
G-3222 Locknut, Vend Assby 7/16" Hex, 1/4-20 (4)
801092 Screw, Main Board, 8-32 5/16 Pan Ph (6)
600876 Outer Panel
06030008 Screw, Display Module 4-40 1/4 (4)

CONSUMABLES & STICKERS

801085 Tube (each)
801154 Column Stickers (for vend assby)
801155 Vend Knob Stickers
801159 Column Currency Decal Stickers
801158 Label, Vend Key
800332 Label, ACO Key
800331 Label, MGR Key
801156 Warning Label, Store Window
801157 Warning Label, Safe