

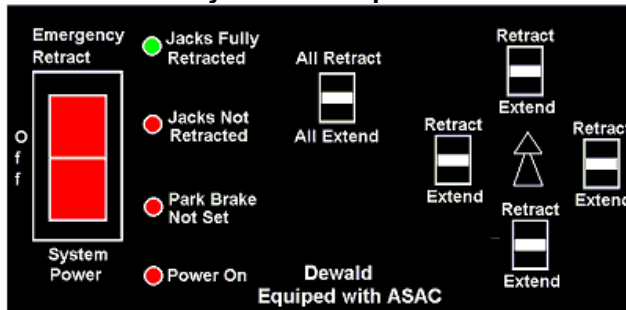

# PARTS AND SERVICE MANUAL for GULF STREAM COACH HYDRAULIC LEVELING SYSTEMS

(with square footpads on jacks)

Manual system touch pad #DN12558



Automatic system touch pad #500629

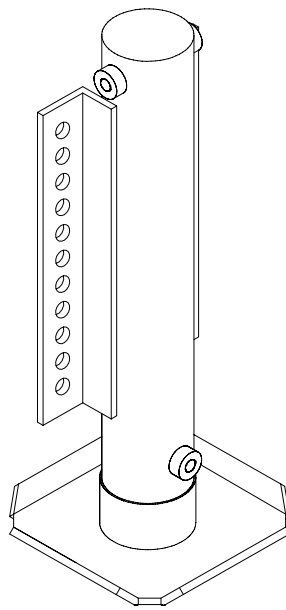
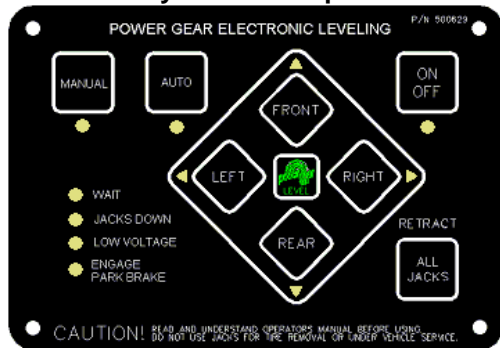

Manual system touch pad #140-1179



Visit us on the web at [www.powergearus.com](http://www.powergearus.com)

# **TABLE OF CONTENTS**

Page 3:	Before you operate the system
Page 4:	Preventive maintenance and recommended fluids
Page 5:	Manual retraction procedure
Page 6:	Parts list
Page 8:	Typical Dewald pump configuration and hydraulic diagram
Page 9:	Instructions for installing o-ring kit #800176
Page 10:	Wiring diagrams
Page 12:	Diagnosing a Dewald cylinder for internal leakage
Page 13:	Troubleshooting guide
Page 19:	Warranty policy

# **WARNING**

- Do not use the Dewald hydraulic leveling system (or air suspension) to support the vehicle while under the coach or changing tires. The hydraulic leveling system is designed as a *leveling* system only.
- Do not use the Dewald hydraulic leveling system as a jack or in conjunction with a jack. It is highly recommended that should a tire need to be changed, a trained professional should perform the service. Attempts to change tires while supporting the vehicle with the hydraulic system could result in damage to the motor home and/or cause serious injury or death.

**CAUTION** - CHECK THAT POTENTIAL JACK CONTACT LOCATIONS ARE CLEAR OF OBSTRUCTIONS OR DEPRESSIONS BEFORE OPERATION.

**CAUTION** - KEEP PEOPLE CLEAR OF COACH WHILE LEVELING SYSTEM IS IN USE.

**CAUTION** - NEVER EXPOSE HANDS OR OTHER PARTS OF THE BODY NEAR HYDRAULIC LEAKS. HIGH PRESSURE OIL LEAKS MAY CUT AND PENETRATE THE SKIN CAUSING SERIOUS INJURY.

**CAUTION** - PARK THE COACH ON A REASONABLY SOLID SURFACE OR THE JACKS MAY SINK INTO GROUND, ON EXTREMELY SOFT SURFACES, USE LOAD DISTRIBUTION PADS UNDER EACH JACK.

**CAUTION** - NEVER LIFT ALL THE WHEELS OFF THE GROUND TO LEVEL THE COACH. DOING SO MAY CREATE AN UNSTABLE CONDITION.

## **BEFORE YOU OPERATE THE SYSTEM**

The leveling system shall only be operated under the following conditions:

1. The coach is parked on a reasonably level surface.
2. The coach "PARKING BRAKE" is engaged.
3. The coach transmission should be in the park or neutral position
4. The ignition is in the run position, or engine is running.

## **SYSTEM DESCRIPTION**

Please read and study the operating manual before you operate the leveling system.

The Dewald electro-hydraulic leveling system consists of the following major components:

- (A) Dewald supplies double-acting jacks rated at a lifting capacity appropriate for your coach. Each jack has a large 8" square (64 square inch) shoe for maximum surface area on soft surfaces.
- (B) Each jack is powered (extension and retraction) from a central 12 VDC motor/pump assembly, which also includes the hydraulic oil reservoir tank, control valve manifold, and solenoid valves.
- (C) The electronic controls located in the coach control the hydraulic pump. There are 2 different control systems:
  - A Manual control system.
  - An Automatic control system, with internal leveling sensor.

## PREVENTIVE MAINTENANCE

1. Check the fluid level every month.
2. Check and/or fill the reservoir with the jacks and room(s) in the fully **retracted** position.
3. The fluid should be within **1/2 inch** of the top of the reservoir tank.
4. Change fluid every **24 months**.
5. Inspect and clean all hydraulic pump electrical connections every **12 months**.
6. Remove dirt and road debris from jacks as needed.
7. If jacks are down for extended periods, it is recommended to spray exposed leveling jack rods with a silicone lubricant every 5 to 7 days for protection.
8. **If your coach is located in a salty environment (within 60 miles of coastal areas), it is recommended to spray the rods every 2 to 3 days with a silicone lubricant.**

### Typical Dewald pump assembly as viewed from behind

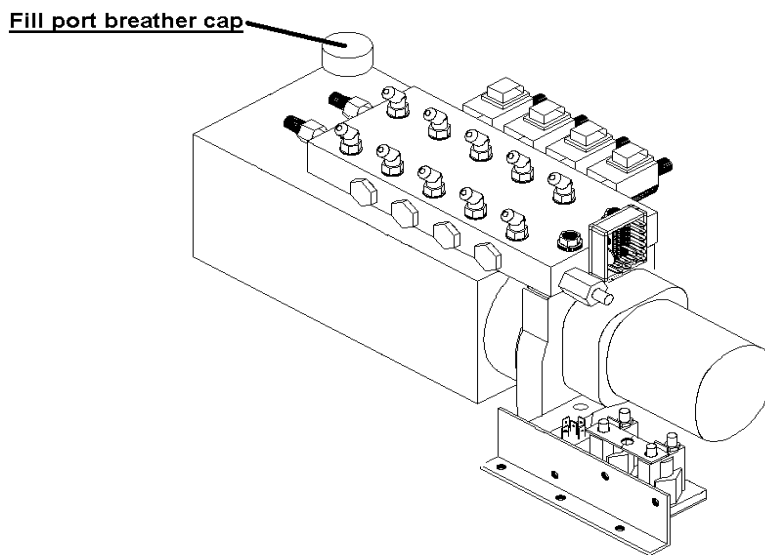

### RECOMMENDED HYDRAULIC FLUIDS FOR YOUR DEWALD HYDRAULIC PUMP

The fluids listed here are acceptable to use in your pump assembly. Your system was originally filled with ISO46 type hydraulic oil (10 wt.). It is not recommended that hydraulic fluid and automatic transmission fluids be mixed in the reservoir.

In most applications, Type A automatic transmission fluid (ATF, Dexron III, etc.,) will work satisfactorily. Mercon V is also recommended as an alternative fluid for Dewald hydraulic systems.

If operating in cold temperatures (less than -10° F) the jacks may extend and retract slowly. For cold weather operation, fluid specially-formulated for low temperatures may be desirable. Mobil DTE 11M, Texaco Rando HDZ-15HVI, Kendall Hyden Glacial Blu, or any Mil. Spec. H5606 hydraulic fluids are recommended for cold weather operation.

**Please consult factory before using any other fluids than those specified here.**

## **WARNING**

**Your coach should be supported at both front and rear axles with jack stands before working underneath, failure to do so may result in personal injury or death**

# MANUAL RETRACTION PROCEDURE

**Note:** Please read the entire *Operations manual for Dewald hydraulic leveling systems* before operating this system.

Your Dewald Hydraulic Power System has been designed to operate both the leveling and slide out system from one power source. This power unit has a built-in hand pump for manually retracting the jacks and slide out room(s) if complete power should be lost to your leveling system.

## Hand Pump Operation

1. Turn each of the small slotted setscrews (A) on the front of the pump assembly clockwise until they stop. This will hold the valves open.

**Note:** Coaches that pre-date 2001 may have a red knurled knob on the end of each valve (A). Instead of turning a setscrew as instructed, you simply pull out the red knobs and turn them a ¼ turn in either direction. When you release them, they will stay locked in the "out" position.

2. Turn the silver (larger) knurled knob (B) on the front of the power unit 2 turns counter-clockwise.
3. Insert the pump handle into the receptacle (C) and pump the hand pump.
4. When all the jacks and the slide out room(s) are fully retracted, tightly close the silver knurled knob clockwise.
5. Turn each of the small slotted setscrews counter-clockwise, until snug.

**Note:** If equipped with red knobs (A), turn them a ¼ turn to pop them back into normal operating position.

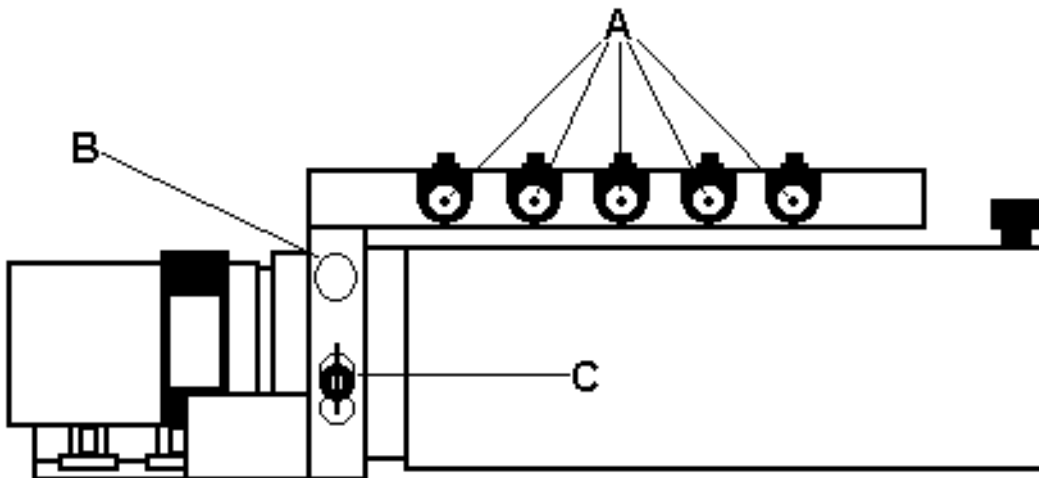

**Note:** Number of valves (A) shown will vary depending on how many slide rooms are operated by the pump assembly.

Please read the owners' manual from the manufacturer who built and designed your motor home for further leveling and slide out room operating information and safety features.

# PARTS LIST

**Typical Dewald pump assembly, as viewed from behind**

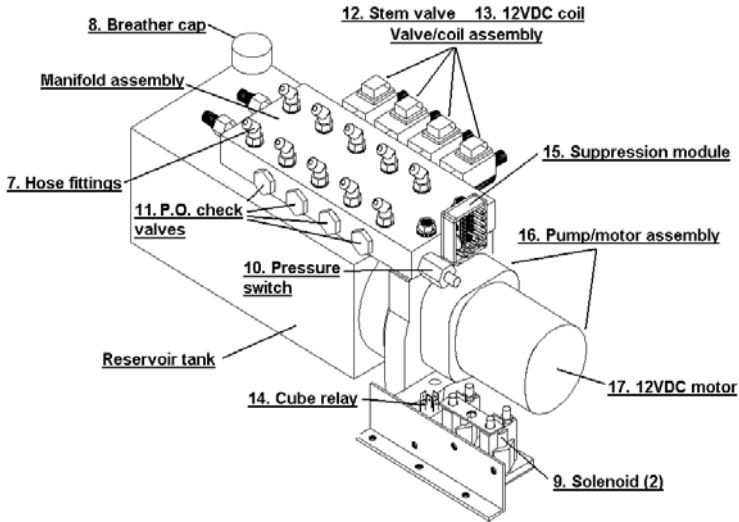

**Pump assembly, front view**

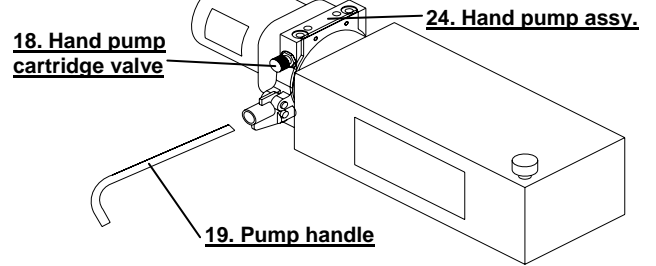

**Air dump valve (diesel coaches)**

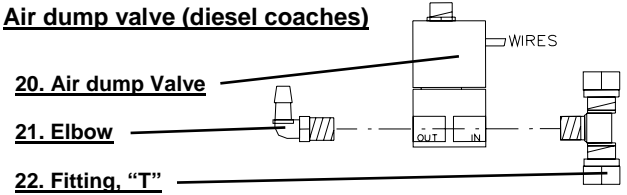

**Item 1. Jack assembly**  
(includes items 2, 3 & 4)

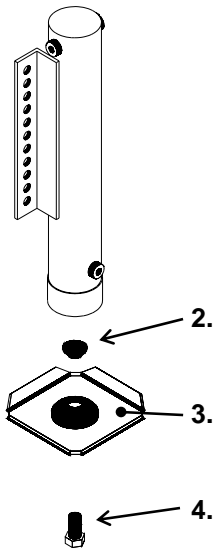

**Jack mounting brackets**

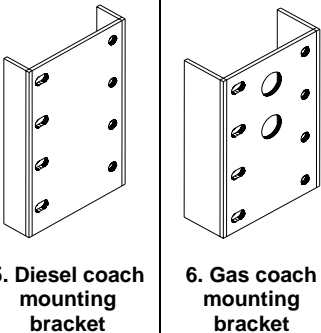

Item	Qty.	Part Number	Description
1	4	DN12989	Jack assy, 3" bore x 15" stroke ( <b>diesel coaches</b> )
1	4	DN12581	Jack assy, 2.5" bore x 13" stroke ( <b>gas coaches</b> )
*		**	Hose assembly ( <b>not shown, see note below</b> )
1		***	Pump assembly
2	1	DN12562	Bushing, foot pivot
3	1	DN12427	Foot pad
4	1	DN12879	Bolt, hex head, 3/4-16 x 1.5, GR 8
5	4	DN12742	Bracket, cylinder to frame mounting <b>11.75"</b>
6	2 or 4	DN12564	Bracket, cylinder to frame mounting <b>11.0"</b>
6	2 or 4	DN14405	Bracket, cylinder to frame mounting <b>16.0"</b>
7	*	DN12494	Hose fittings
8	1	PT10000	Breather cap
9	2	WZ10000	Solenoid
10	1	DN12457	Pressure switch
11	*	DN13932	P.O. check valve
12	*	DN13933	Stem valve
13	*	DN13937	12VDC coil
14	1	BA30000	Cube relay
15	1	DN12649	Suppression module ( <b>not used on pumps w/ 500629 touchpad</b> )
16	1	OK21500S	Pump/motor assembly
17	1	DN11027	12VDC motor only
18	1	DN14866	Hand pump cartridge valve
19	1	DN12560	Pump handle
20	1	DK10650	Valve, air dump/safety ( <b>diesel coaches</b> )
21	1	DN12738	Elbow, 90 degree
22	1	WO13200	Fitting, "T"
23	1	500919	Harness, pump (see pg 10) (used on pumps w/ 500629 touchpad)
24	1	600072	Hand pump assy
1		800176	O-ring seal kit for Dewald pump assemblies ( <b>see pg 8</b> )
1		DN12558	Touch pad, manual system ( <b>not shown, see front cover of manual</b> )
1		500629	Touch pad, automatic system ( <b>not shown, see front cover of manual</b> )
1		140-1170	Control box ( <b>see pg 10</b> )

\* Quantities vary by system.

\*\* Hose assemblies should be ordered by the length of the hose in inches.

\*\*\* See page 7 for description and part numbers for ordering Dewald pump assemblies'

Note: Information regarding Dewald slide out parts, service, and troubleshooting can be found in the *Parts and Service Manual for Dewald Hydraulic Side Out Systems*.

## PUMP ASSEMBLIES

<b>Leveling and slide room pump assy's (Square reservoir tanks)</b>		
Square reservoir tanks come in 6 and 8 quart sizes. The length of the 6 qt tank is 12" and the 8 qt is 14" long.		
<b>6 quart pump assemblies</b>		
PU12463 6 qt leveling only (3 valve)	w/ diode = Assembly is built with diode harness on solenoids  w/ diode on coil = Assembly is built with diodes inline on room coils  w/ fuse = Assembly is built with fuse in line on red power lead for wall switches	
PU12464 6 qt leveling + 1 (4 valve)		
PU12479 6 qt leveling + 2 (5 valve)		
PU12598 6 qt quad-slide pump (4 valve)		
PU13080 6 qt leveling + 1 w/ diode on coil (4 valve)		
PU13081 6 qt leveling + 2 w/ diode (5 valve)		
PU13631 6 qt leveling + 1 w/ fuse (4 valve)		
PU13635 6 qt leveling + 2 w/ fuse (5 valve)		
<b>DMI pumps with PG controls</b>		
500945 6 qt leveling + 2 w/ fuse (5 valve)		
500956 6 qt leveling + 1 w/ fuse (4 valve)		
<b>8 quart pump assemblies</b>		
PU13358 8 qt leveling + 2 w/ diode (5 valve)		
PU13632 8 qt leveling + 1 (4 valve)		
PU13633 8 qt leveling + 1 w/ diode on coil (4 valve)		
PU13634 8 qt leveling + 1 w/ fuse (4 valve)		
PU13636 8 qt leveling + 2 (5 valve)		
PU13637 8 qt leveling + 2 w/ fuse (5 valve)		
500951 8 qt leveling + 3 w/ fuse (6 valve)		

### Typical Dewald pump configuration

**Note:** Various pump configurations exist; including systems designed for leveling only, leveling plus one slide room, leveling plus 2 rooms, and leveling plus 3 rooms. The pump and hydraulic diagrams pictured below are for a leveling + 2 slide room system.

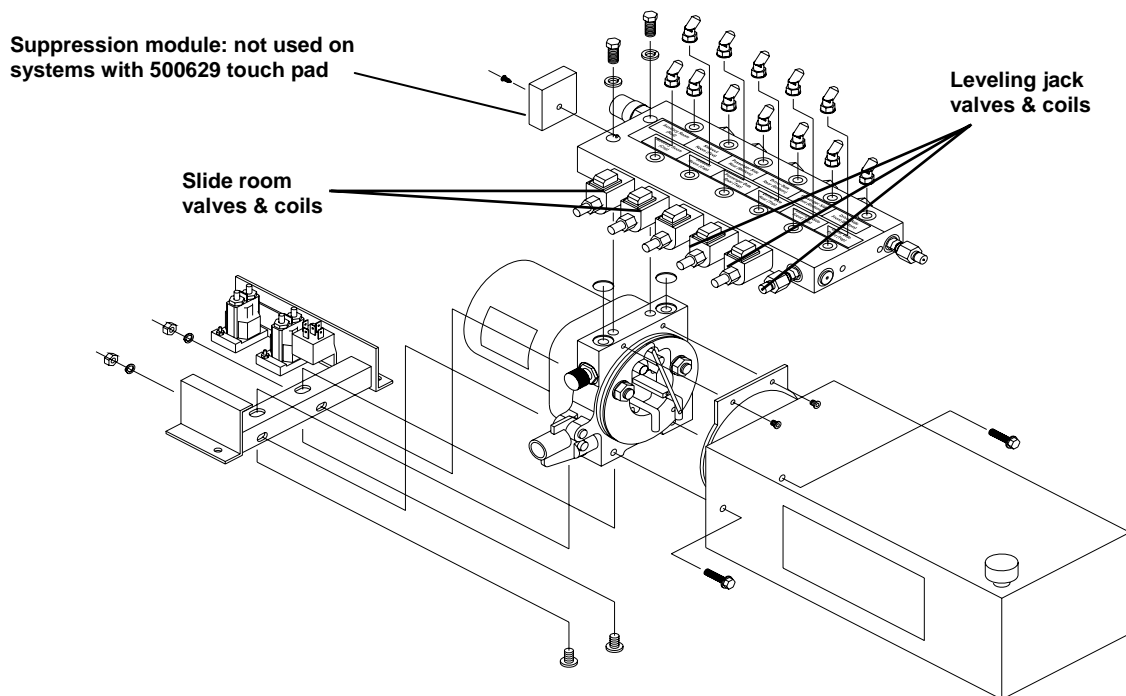

## Dewald hydraulic diagram

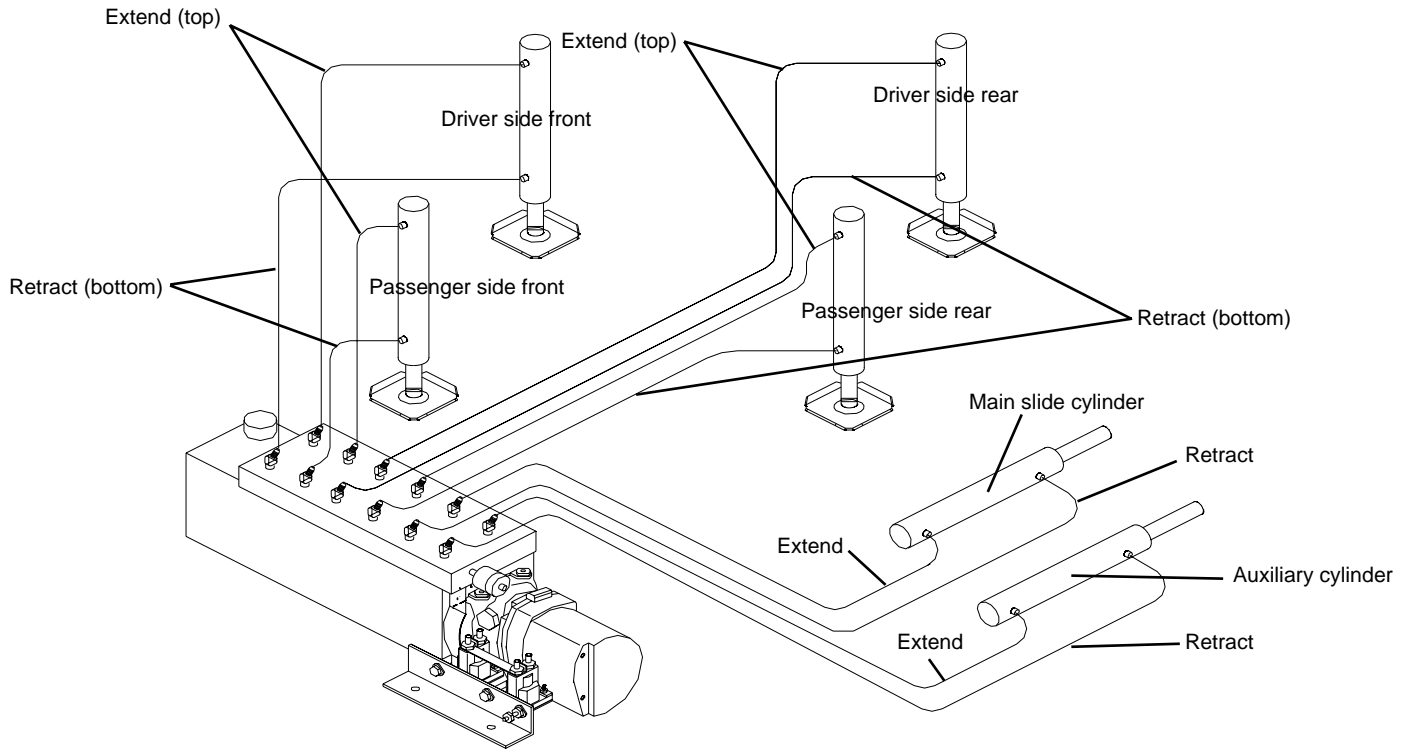

## HYDRAULIC DIAGRAM

ESV (Electric Solenoid Valve) Triple ESV shown

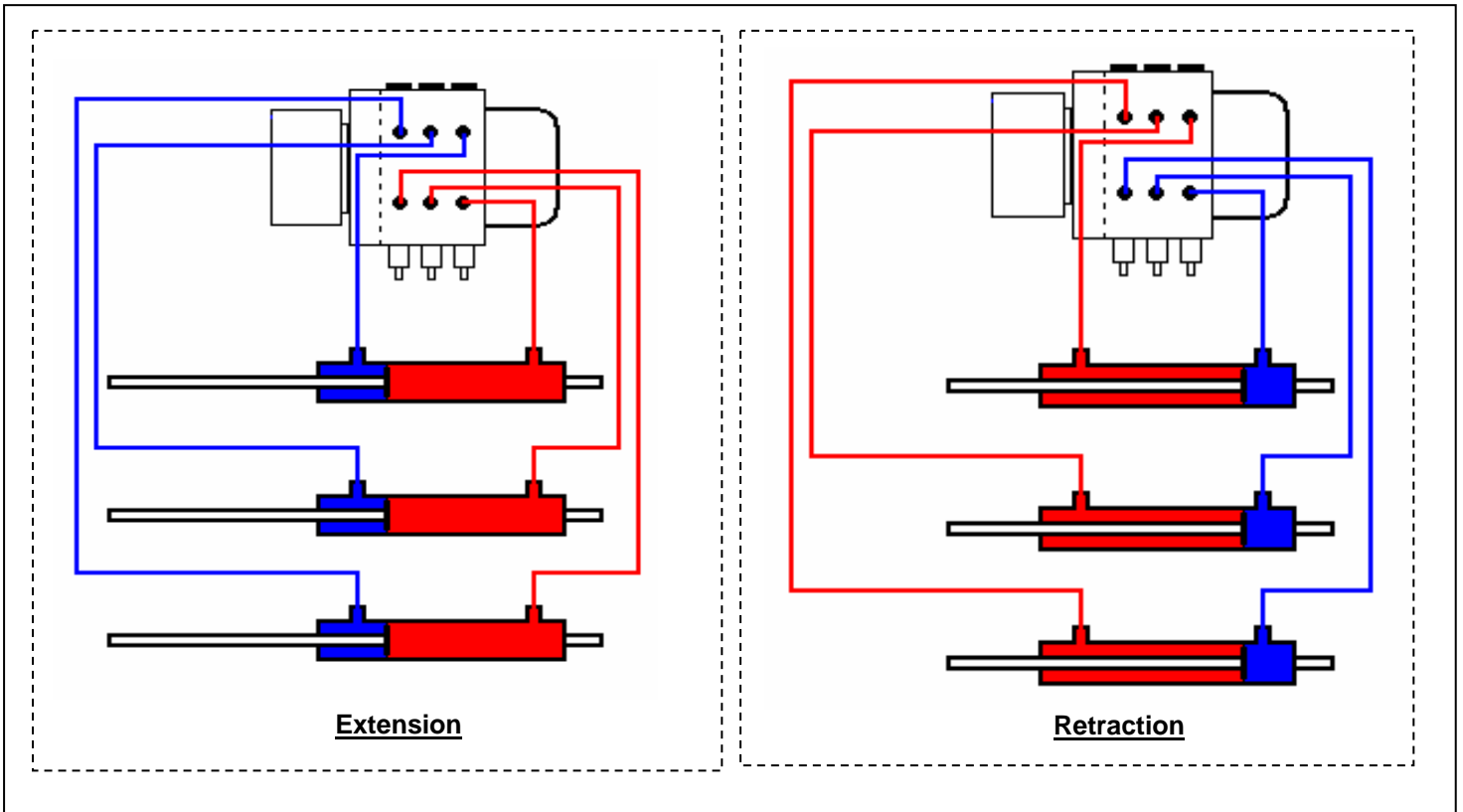



# ELECTRIC SOLENOID VALVE HYDRAULIC SCHEMATIC

## Extension

## Retraction

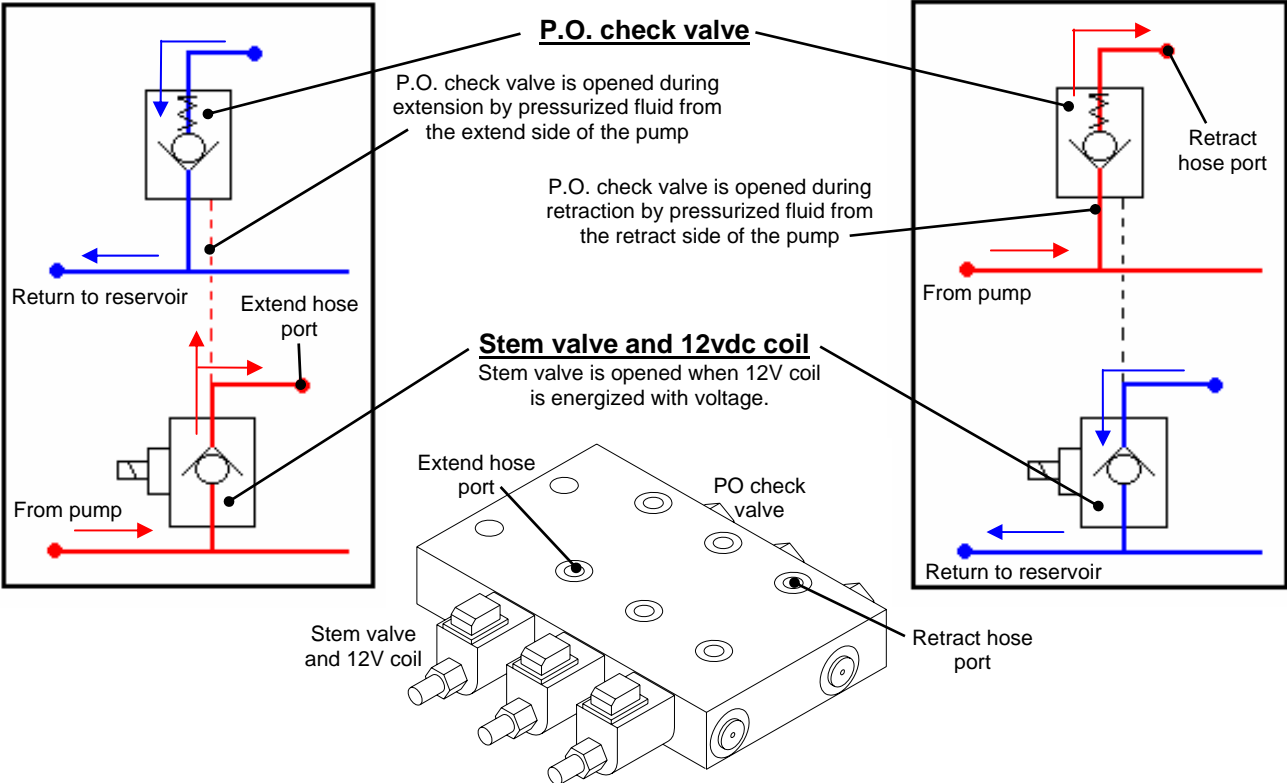

## Instructions for installing seal kit 800176

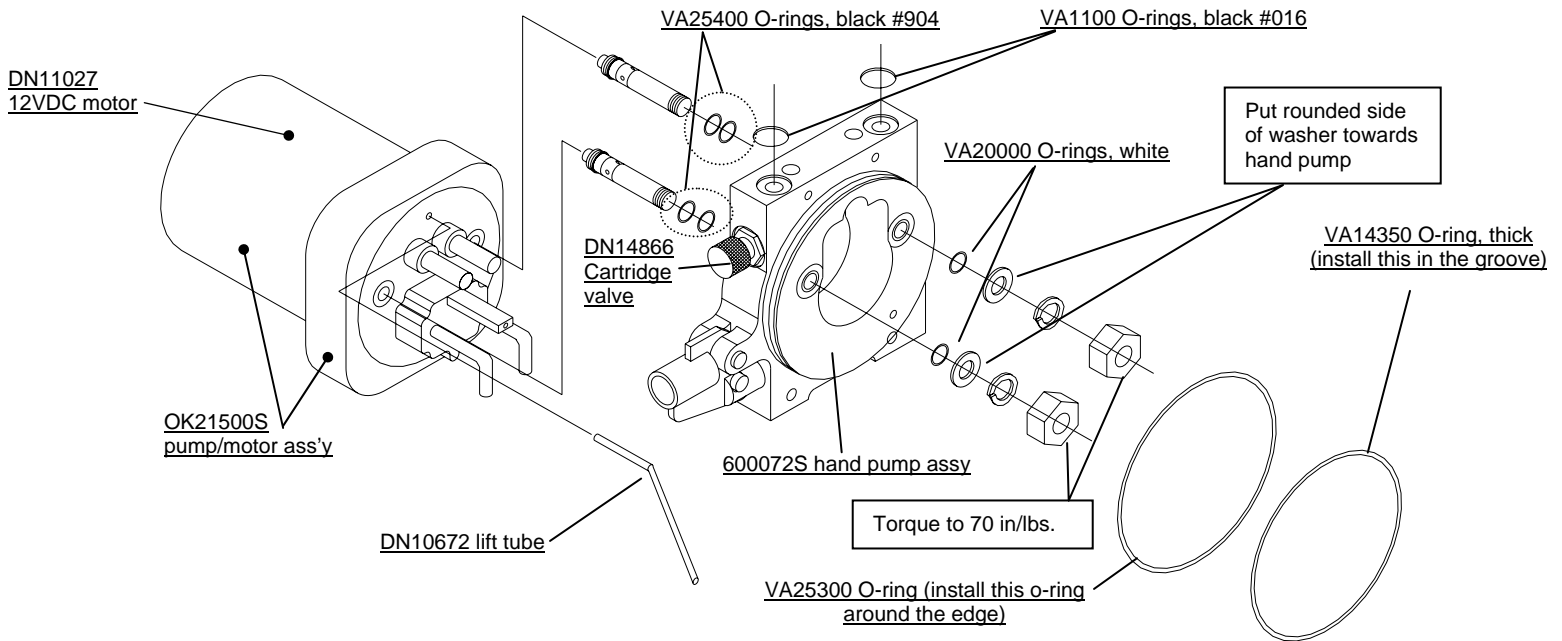

### Seal kit 800176 contains the following parts:

<u>Qty.</u>	<u>Part #</u>
2	VA11000
2	VA14350
2	VA20000
1	VA25300
4	VA25400

1. Return all rooms and leveling legs to the travel/ storage position.
2. Disconnect the battery for the coach and pump system.
3. Drain the tank of oil with a siphon.
4. Mark each hose, and wire for their respective positions.
5. Remove each hose from the pump assy. and insert the ends into a bucket in case of leakage.
6. Remove the power leads to the pump motor (green, blue, and black).
7. Remove the pump from its mounting bracket. Take it to a clean, well-lighted workbench for disassembly.
8. Remove the tank; drain any remaining fluid and clean inside of tank with a lint free cloth.
9. Remove the hand pump from the assembly by removing the two nuts and lock-washers. Removal may be difficult with the inlet strainers in place. While pulling the hand pump off of the hollow tubes, pivot the hand pump down to clear the strainers after it clears the tubes.
10. Insert a long Allen wrench small enough to fit through the holes in the hollow tubes to check them to make sure they are tight (right hand thread).
11. Clean the components before re-assembly.
12. Install 2 new o-rings (VA25400) onto each tube (4 total), lubricate them with Dexron III.
13. Re-install the hand pump onto the pump assy.
14. Install one white o-ring (VA20000) onto each of the two tubes. Push the assembly together as much as possible to align the housing and tubes so the o-rings will be seated correctly.
15. Re-install the nuts onto the tubes and tighten to 70 inch/ pounds.
16. Install new o-rings (VA14350 and VA25300, 1 each) onto hand pump assembly and re-install the tank.
17. Re-install the pump components in reverse order of disassembly making sure to match the hose and wire markings.
18. Re-fill the tank with Dexron III fluid until ½" from the top of the tank.
19. Run the rooms and or leveling legs to full extension, wait 30 seconds and retract the rooms and leveling legs. Repeat this 4 times. This should completely purge air from the system.
20. Check the fluid level in the tank with all rooms and jacks retracted. Fill to proper level if necessary.
21. Test the system for proper operation, leaks, etc.

**Note: Some systems do not require The two (2) VA25400 o-rings. One(1)extra VA14350 o-ring is included in the kit .**

# Wiring Diagram for systems with touchpad #DN12558

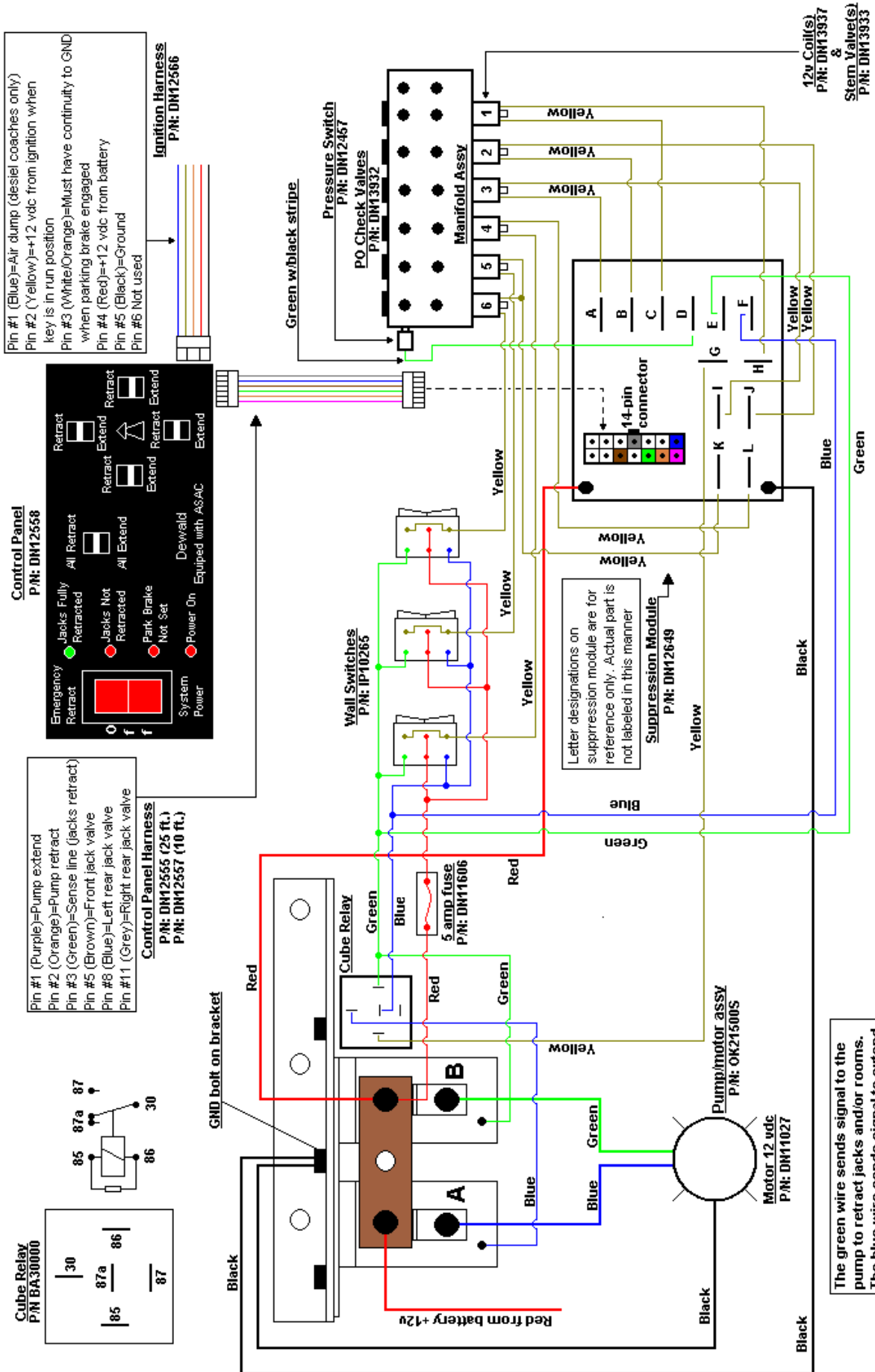

# Wiring Diagram for systems with touchpad # 500629 OR 140-1170

\*\*\*Item 23, pg 4. 500919 pump harness

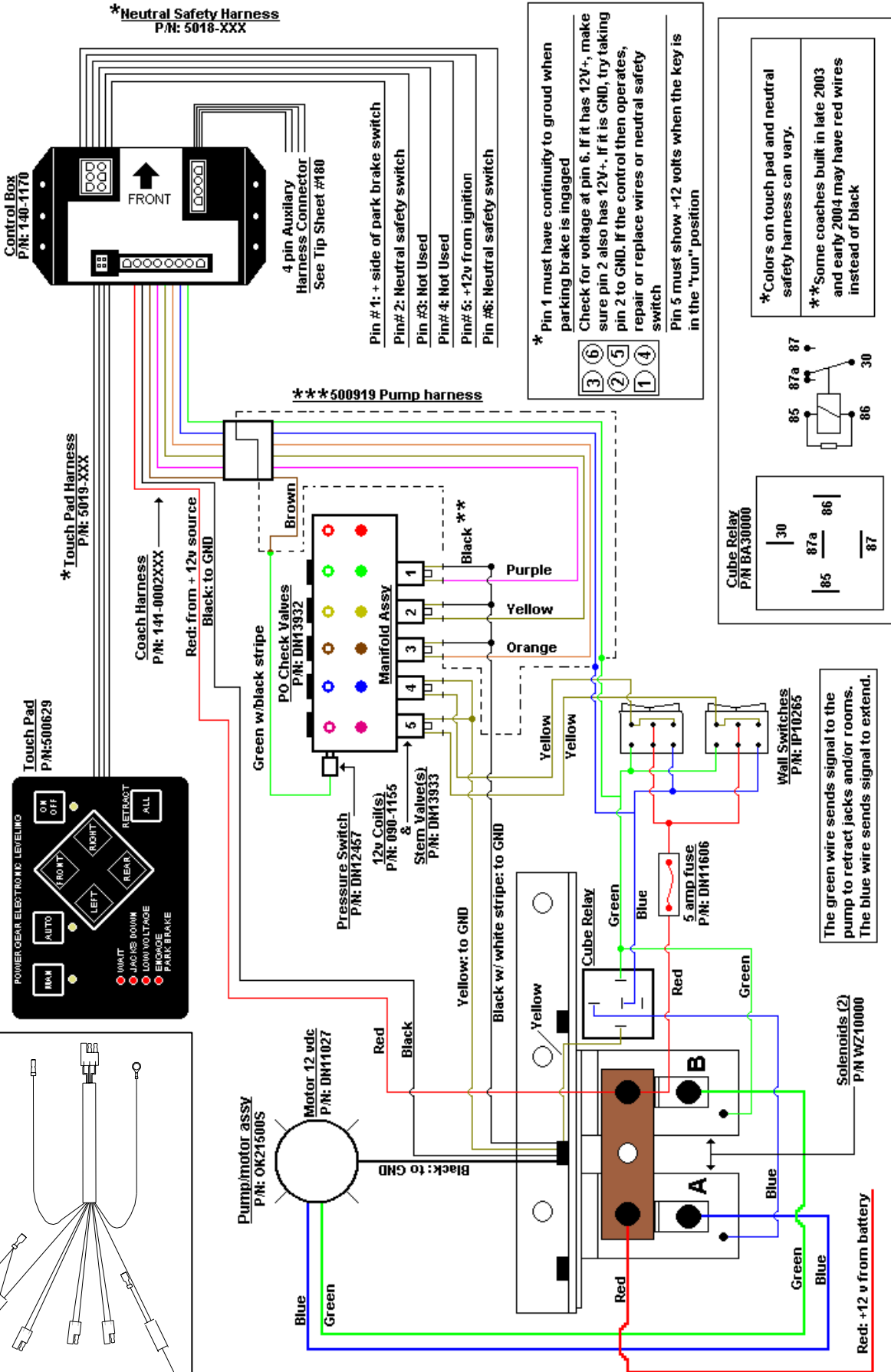
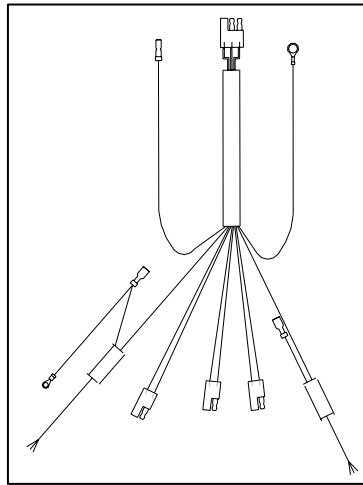

# Wiring Diagram for systems with touchpad # 140-1179

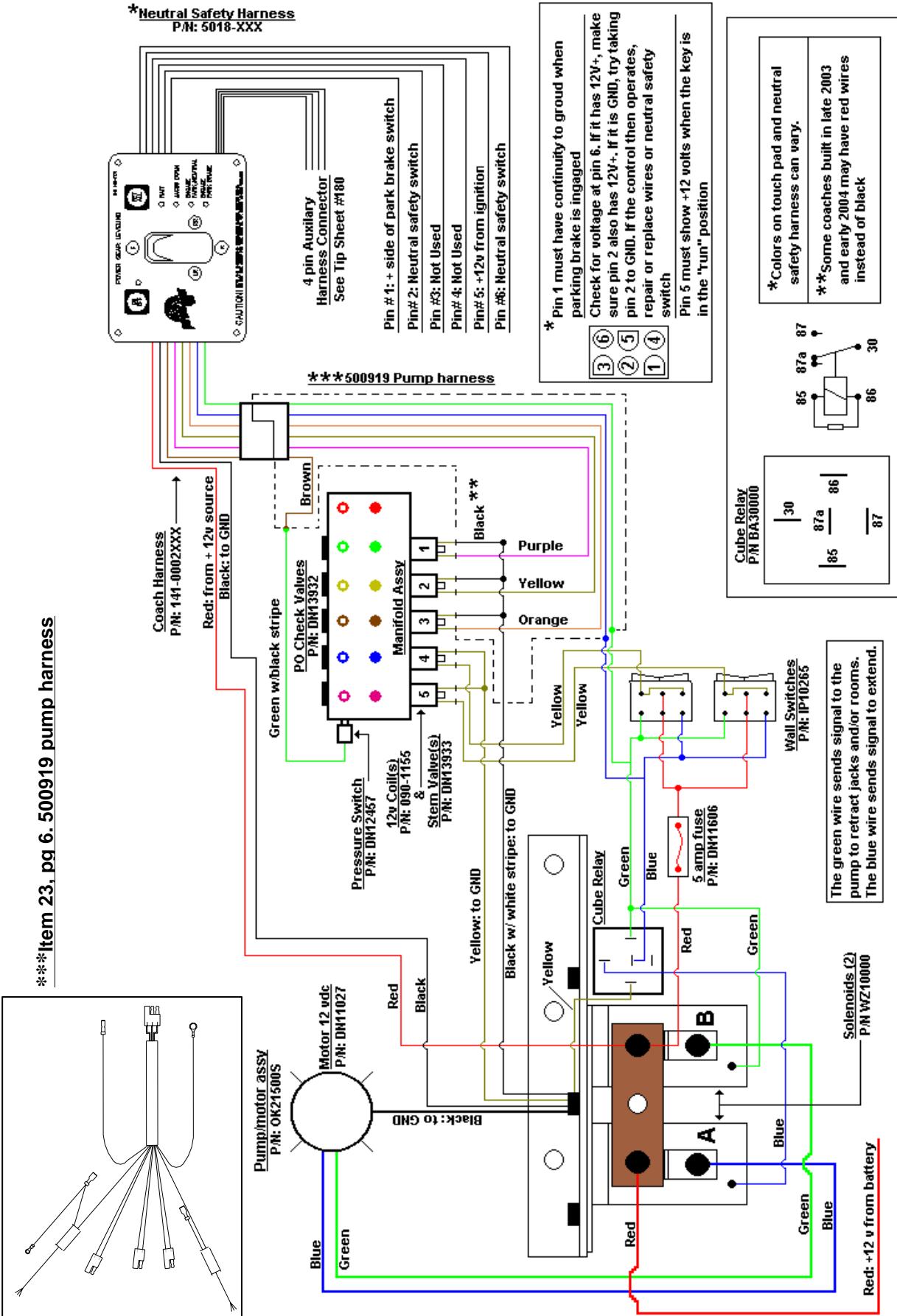

\*\*\*Item 23, pg 6. 500919 pump harness

## **Diagnosing a cylinder for internal leakage**

The piston seal inside of a hydraulic cylinder can deteriorate over time due to normal wear, contaminated fluid, etc.  
FIELD TECHNICIANS THAT DO NOT HAVE A GAUGE AND GATE VALVE TOOL CAN DIAGNOSE USING THE FOLLOWING METHOD

**Check only one cylinder at a time.**

- 1: Completely RETRACT suspected cylinder.
- 2: Remove the EXTEND hose at the cylinder. See page 7 for hydraulic diagram to determine EXTEND and RETRACT hoses.
- 3: Push the RETRACT or IN switch for at least 10 seconds and note how much fluid is coming from the fitting. A small amount to trickle is normal, steady flow is not. The pump will groan but hold the switch for as long as 10 seconds. If internal piston seal is good, little to no fluid should be coming out of fitting.
- 4: If, at this point, the seal has proven to be faulty, then repair or replace cylinder. If seal appears to be holding pressure, continue with the diagnosis.
- 5: Re-attach the removed EXTEND hose.
- 6: Completely EXTEND suspected cylinder. If a vehicle lift is not accessible, it may be necessary to park the coach over a service pit to get leveling cylinder completely extended without lifting coach.
- 7: Remove the RETRACT hose at the cylinder.
- 8: Push the EXTEND or OUT switch for at least 10 seconds and note how much fluid is coming from the fitting. A small amount to trickle is normal, steady flow is not. The pump will groan but hold the switch for as long as 10 seconds. If internal piston seal is good, flow should be greatly reduced or stopped by then.
- 9: Do this with each cylinder, to determine a faulty cylinder.

**Note 1:** Rooms that take hours or days to start drifting must use the gauge diagnostic method.

**Note 1:** This process will greatly reduce your diagnostic times for the identification of potential bad cylinders.

**Note 3:** Cap or hold your finger over the pump fitting of the removed hose to avoid drawing air into the system.

# Diagnosing drifting rooms with a gauge and gate valve

Probable Cause	Corrective Action
Leaks somewhere in the system	Check all hydraulic hoses for visible leaks. Check that all connections are tight.
	Diagnose and replace as necessary any faulty cylinder
Stem valves are in manual override position	Turn slotted set screws at the end of the valves counterclockwise until they stop. If system has red knobs instead of set screws, turn knobs until they "snap" back into position.
Faulty stem valve	Swap the suspicious valve with one of the other good valves. If the problem follows the valve, check for bad o-rings on the tip of the valve. If o-rings are OK, change valve.
Faulty P.O. check valve	Swap the suspicious check valve with a good check valve. If the problem follows the check valve, check for damaged o-rings. If the o-rings are OK, change check valve.
Valve coils miswired	Check wiring diagrams.
Cylinder(s) leaking	Replace cylinder or have cylinder resealed
Bad o-ring in pump assembly	Install o-ring replacement kit #800176.

3000 psi Gauge shown with quick disconnect for connecting to the fill/purge fittings on the pump.



Gauges assembled as shown here will be the most versatile for all applications.

## Do you have a hydraulic problem causing the room to drift? Take this first Step in diagnosing.

- A. Relieve pressure on the system by moving the cylinders to somewhere in the middle of their stroke.
- B. Couple the gauge to the fill /purge fitting on the pump on the same side as the outlined color side of the decal (retract side-decal on the hose may say bottom or rod side of the cylinder).
- C. Run the pump to retract the jacks with the control. The pump should run for 5-7 seconds after reaching 1400psi, and should achieve at least 2000psi.
- D. Watch the pressure. If the pressure falls below 1750 psi the system has a leak. The leak could be internal (and thus not visible), or external.

This gauge is installed onto the retract side of the pump's manifold. This will show if any portion of the system has a problem. It will not show you where the problem is however. The benefit of checking like this is that the gauge can be installed without creating a mess, and it is very quick.

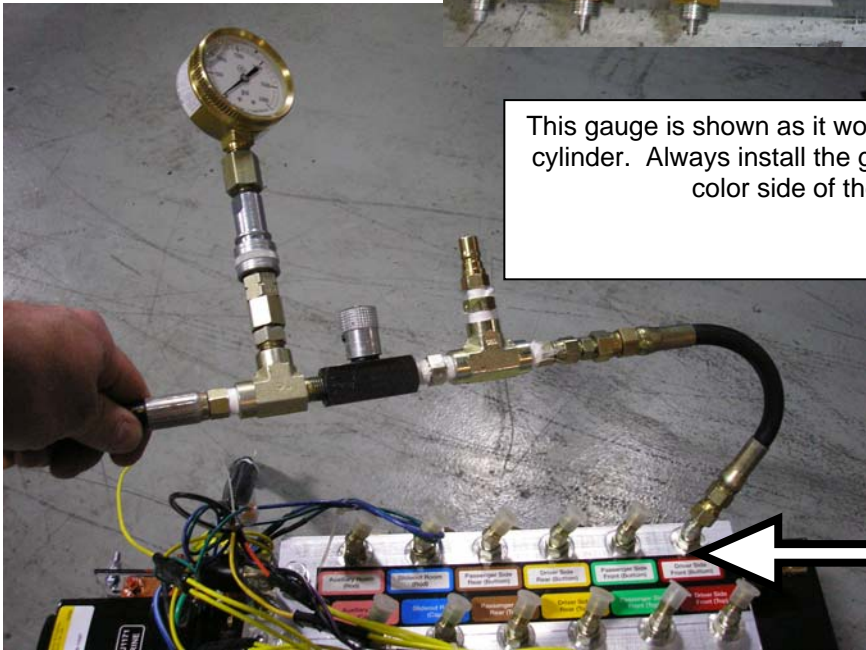
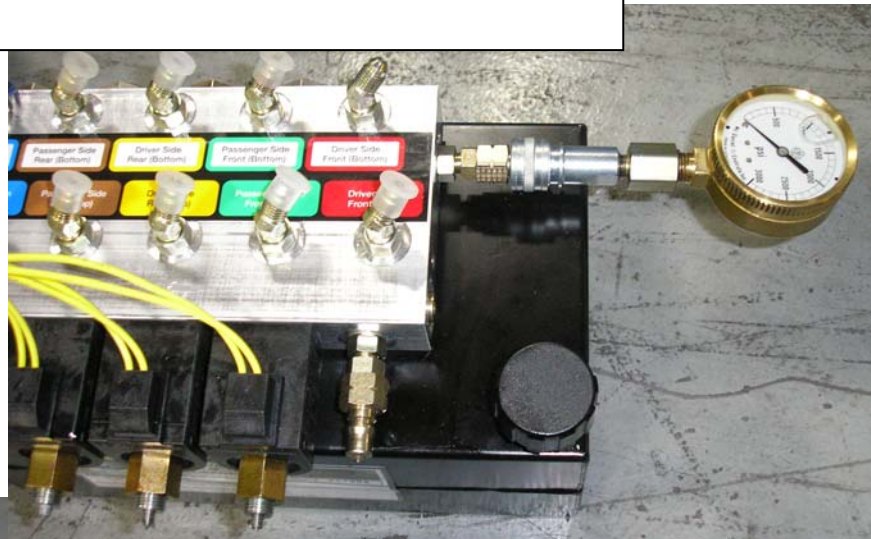

This gauge is shown as it would be installed on a pump for checking a bad cylinder. Always install the gauge on the hoses hooked up to the outlined color side of the decal, not the solid color side.



## How do I use the gauge and gate valve to find the exact location of the problem?

- 1) Relieve pressure on the system by moving the cylinder being checked to the middle of it's stroke. Check the longest cylinders first (usually the main room).
- 2) Assemble the gauge and gate valve as shown in the diagram. Open the gate valve.
- 3) Run pump to 2000 psi. or more by retracting the room or jack, then shut the gate valve quickly.
- 4) If the gauge on the cylinder side of the valve is leaking off pressure one or both of the cylinders has a bad piston seal. If the system has two cylinders for that room, proceed to step 10.
- 5) If the gauge on the pump side of the gate valve is leaking off pressure, continue the test with the next longest set of cylinders (usually a galley slide).
- 6) If all slide cylinders have been checked and are good, test the front leveling jacks.
- 7) If the front jacks are OK then test each of the rear jacks.
- 8) If all cylinders have been tested and are OK the pump is bad. Replacement pump part number is OK21500S. (does not include tank or manifold)

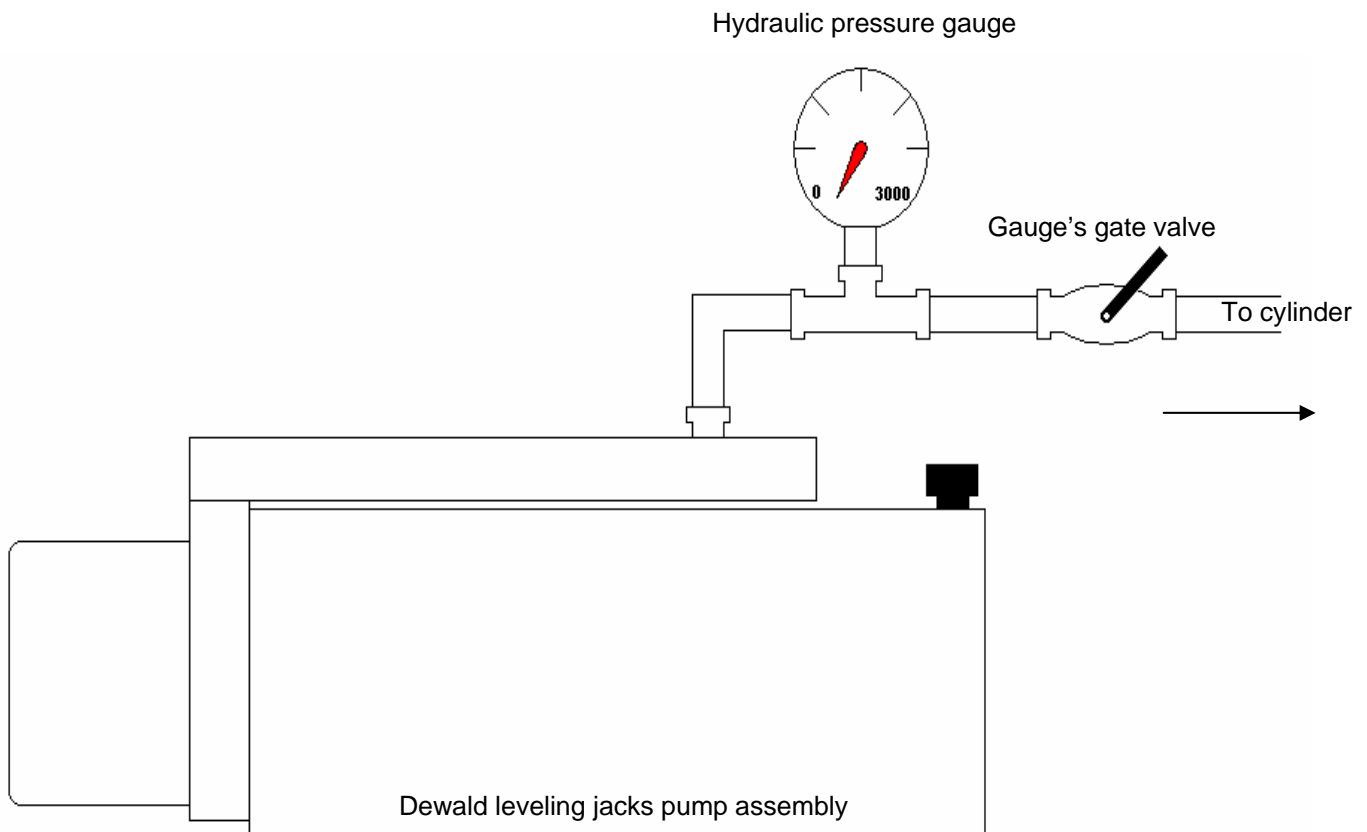

## Systems using two hydraulic cylinders per slide room:

- 10) Relieve pressure on the system by moving the cylinder(s) being checked to the middle of their stroke.
- 11) Move the gauge so that it is between the cylinders on the retract hose.
- 12) Open the gauge's gate valve.
- 13) Retract completely (more than 2000 psi).
- 14) Shut off the gauge's gate valve.
- 15) Watch for falling pressure until the difference between gauge readings is noticeable.

NOTE: The cylinder with the leak will be the one on the side of the gauge displaying the lowest pressure.

NOTE: Some seals leak slower than others. If the room takes several days before drifting, extend the time that you observe the cylinder retraction pressure.

NOTE: If a slide cylinder is found to be causing the low pressure, refer to the slide systems manual for more specific information about replacement tips and techniques for making the cylinder replacement easier.

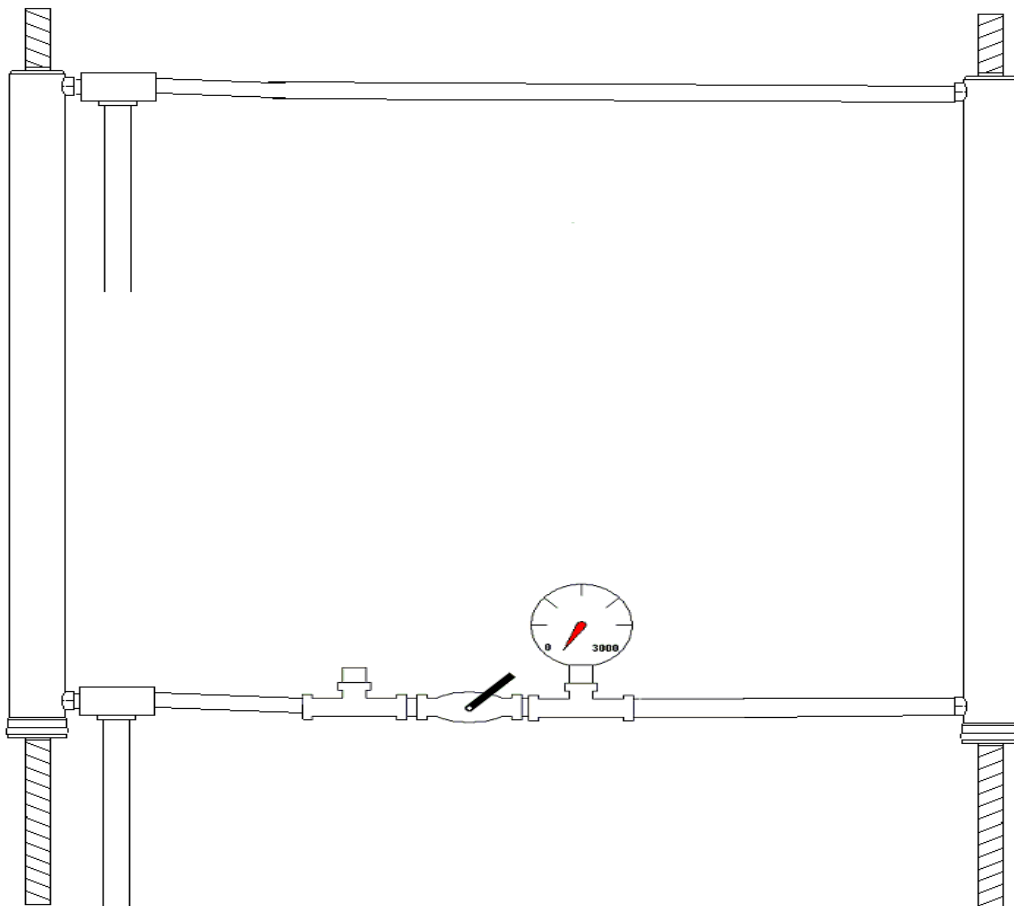

## **AUTOMATIC LEVELING SYSTEM SET-UP & RECALIBRATION PROCEDURE**

**Note:** The following set-up and recalibration procedure is for control 500630 or 140-1170 (used with touch pad 500629)

### **Set-Up Procedure**

Follow this procedure to reprogram a new zero point (stored level position):

- 1) Turn the ignition on and the touch pad on, wait for the lights to stop revolving.
- 1) Place a carpenter's level on the floor in the center of the coach
- 2) Manually level the coach by pushing the "MAN" button for 5-7 seconds until the light comes on beneath the button.
  - Push the front button until the jacks contact the ground
  - Push the rear button until the jacks contact the ground
  - Push the left and the right button to verify that all of the jacks are on the ground.
  - Using the carpenter's level, complete the leveling process manually by pushing the appropriate buttons on the touch pad. Verify that the coach is level.
- 3) Turn the ignition on and the touch pad off.
- 4) Push the front button 5 consecutive times followed by the rear button 5 consecutive times within 10 seconds
  - All of the LEDs on the touch pad will begin flashing. This indicates that you have successfully returned the control box to zero mode
- 5) Push the retract button three consecutive times (the new zero point has now been set)
- 6) After the retract button has been pushed three times all of the LEDs on the touch pad will stop blinking except the On/Off LED. The On/Off LED will flash for 20 seconds. Wait until the light stops blinking, then turn the key switch off.  
The control has now been reprogrammed.

## Power Gear Leveling Controls

### 500630 (Rev. 2 and higher), 140-1170 & 500674 (Rev. 1 and higher) Error Codes

An *error code* is indicated by certain LEDs (on the touch pad) blinking in a given pattern.

Find the pattern you are seeing (under “Indication”) in the chart below to find the mode.

Then find the Mode in the paragraphs that follow to find a fix for the problem.

**Note:** The 500630 and 140-1170 controls are used with the 500629 touch pad. The 500674 control is used with the 500675 touch pad.

**Note:** Any reference to the *All Level* LED refers to the green “Power Gear” LED in the center of the diamond pattern. During normal operation, this LED comes on to indicate that the coach is level.

#### Indication (blinking LEDs) Modes:

<b>All Level</b>	=	Already Level
<b>On/Off, Jacks Down &amp; Park Brake</b>	=	Panel Communication Error
<b>Park Brake</b>	=	Park Brake signal has been lost
<b>Wait &amp; On/Off</b>	=	Transmission neutral signal has been lost
<b>All of the LEDs are blinking</b> (and a buzzer is on and the jacks are retracting)	=	Emergency Retract
All of the LEDs are blinking Zero Mode		
<b>Left, Right, Front, Rear &amp; All Level</b>	=	Out of Level Tolerance
Wait	=	Wait
Low Voltage	=	Low Voltage
Left, Right & All Level	=	Failure Mode

#### Mode: **Panel Communication Error**

Indication:

The following LEDs are blinking together: On/Off, Jacks Down & Park Brake

Cause:

Poor connection between components or faulty component

Fix:

Check to make sure that all connections are tight and properly connected. Cycle power to reset. If that does not work, try replacing components individually, starting with the wire harness, then the touch pad, and lastly the control

#### Mode: **Park Brake**

Indication:

Park Brake LED is blinking

Cause:

Park brake is not engaged OR improper wiring of the parking brake wire

Fix:

Engage park brake. If that does not work, check the wiring of the park brake wire

Mode: **Emergency Retract**

Indication:

Buzzer is on, all of the LEDs are blinking, and the jacks are retracting

Cause:

While the jacks are down and the ignition is in the run position, the parking brake is disengaged  
OR

Improper wiring of the parking brake wire(s)

OR

loss of pressure switch signal

Fix:

Engage park brake and make sure coach is not in gear while the jacks are down or while extending jacks. Check the signal from the pressure switch (see wiring and trouble shooting guides). If problem persists, check the wiring of the parking brake wire(s)

Mode: **Zero Mode**

Indication:

All LEDs are blinking together

Cause:

Unit is brand new OR user put system into this mode. Unit is waiting for a programmed level position

Fix:

See page entitled **AUTOMATIC LEVELING SYSTEM SET-UP & RECALIBRATION PROCEDURE**

If unit is not brand new, and you want to keep the previously stored level position, cycle the key off and then back on

Mode: **Out of Level Tolerance**

Indication:

The following LED's are blinking together: Left, Right, Front, Rear, and All Level

Cause:

Coach is SO FAR out of level that jacks won't help

OR

Control was previously programmed at a position that was not level

OR

Control was not securely fastened in place when level was programmed

Fix:

Move coach to ground that is more level. If you know you are on fairly level ground, then re-program a new level position -- See page entitled **AUTOMATIC LEVELING SYSTEM SET-UP**

**& RECALIBRATION PROCEDURE**

Mode: **Wait**

Indication:

The Wait LED is blinking

Cause:

The control is busy. The LED will stop blinking in less than one minute

**Mode: Low Voltage**

Indication:

The Low Voltage LED is blinking

Cause:

The voltage is low at the control (below 10.5 volts)

Fix:

Charge or replace the battery. *If a leveling procedure is being attempted, the coach should be running to ensure a good voltage supply at the control*

*Check the wiring to the control between wire 5 of the 6 pin connector and wire 1 of the 8 pin connector. Voltage less than 10.5 volts needs appropriate repairs.*

**Mode: Failure mode**

Indication:

The following LED's are blinking together: Left, Right, and All Level

Cause:

Retract timeout— when retract is active for 2 minutes and pressure switch does not indicate jacks up  
OR

Any internal failure — could be caused by a poor connection or faulty component

Fix:

Check the pressure switch signal.

Check to make sure that all connections are tight and properly connected.

Cycle power to reset. If that does not work, try replacing components individually, starting with the wire harness, then the touch pad, and lastly the control

## Troubleshooting the leveling system



**Note:** Information regarding Dewald slide out parts, service, and troubleshooting can be found in the *Parts and Service Manual for Dewald Hydraulic Slide Out Systems*.

Before starting to troubleshoot the system, check all harness connectors for proper connection. Also look for any loose or hanging wires and replace, tighten or connect as necessary according to the wiring diagrams contained in this manual. Use the wiring diagrams supplied in this manual to locate and identify leveling system components referred to in this troubleshooting guide.

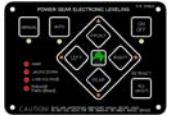
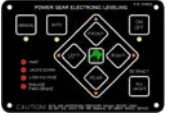
**Troubleshooting any Direct Current (DC) electrical system should be done with caution and by a trained technician. Anyone unfamiliar with electrical systems should not attempt the troubleshooting procedures listed in this guide. Failure to follow these guidelines could result in personal injury or even death.**



<b>System will not turn on, and/or “on/off” indicator light will not illuminate</b>		
Touch pad #	Probable Cause	Corrective Action
<b>Both</b>	Batteries disconnected	Reconnect batteries, and/or check connections.
	Battery voltage below 10V	Charge batteries, or replace if necessary.
	Coach ignition not in run position	Turn ignition to run position .
<b>DN12558</b> 	6-pin harness not plugged in properly	Check 6-pin harness for proper connection.
	No power to touch pad	Pin 4 of the 6-pin connector must have 12V+ with the ignition in the run position. Check for blown fuse on the red wire of the 6-pin connector. Replace fuse with a 6.25 amp Slo-Blo fuse, if necessary.
	Ground wire disconnected or shorted	Pin 5 of the 6-pin connector is a ground wire. Test for continuity with ground.
	Faulty control	If previous causes and actions do not apply, replace the touchpad.
<b>500629</b> 	Transmission not in park or neutral	Place transmission in park or neutral.
	Parking brake not set	Set brake.
	Control has been left on for more than four minutes, auto shut off	Turn off the touch pad, and then turn back on.
	Ground wire disconnected or shorted	Pin 1 of the 8-pin connector is the ground. Test for continuity with ground.
	Neutral safety wires shorted	Check for voltage at pin 6 of the 6-pin connector on the control. If it has 12V+, make sure pin 2 also has 12V+. If it is ground, try grounding pin 2. If the control then operates, repair or replace wires or neutral safety switch.
	Parking brake wire not grounded, or faulty parking brake switch	Check continuity between pin 1 of the 6-pin connector and ground. If there is no continuity, the switch is bad, the parking brake is not set, or the wires to the switch are bad.
	Faulty control	If previous causes and actions do not apply, replace the controls.
<b>System turns on, but shuts off as soon as a button is pushed</b>		
Touch pad #	Probable Cause	Corrective Action
<b>500629</b> 	Low system voltage	Voltage must remain above 10V while in operation. Check battery condition and connections

## Any or all jacks will not extend, pump does not run

Touch pad #	Probable Cause	Corrective Action
<b>Both</b>	Bad connection of motor ground wire at pump	Check grounding of black wire coming directly out of 12VDC motor at the pump assembly.
	No power to pump assembly	Check for 12V+ at the pump assembly on the copper buss bar that ties solenoids "A" and "B" together. If power is found, jumper the two large posts on solenoid "A" to see if pump will run. If pump runs then continue trouble shooting system to isolate problem.
	Motor or pump has failed	Check for continuity between blue and black wires of 12VDC motor. If no continuity, replace motor. If continuity is found, then replace pump/motor assembly.
	Solenoid "A" faulty	With any jack extend switch pushed, small post of solenoid "A" should show 12V+. If so, then two large posts of solenoid "A" should have continuity across them. If no continuity, replace solenoid.
	No signal to solenoid "A" from cube relay	With any jack extend switch pushed, small post of solenoid "A" should show 12V+. If not, check for voltage at terminal 30 of cube relay. If no voltage, replace cube relay.
<b>DN12558</b> 	Parking brake not set, wire not grounded, or faulty parking brake switch	Set brake ("park brake not set" light should go out). If brake is set and light does not extinguish, check for continuity to ground at the orange wire with white stripe on the 6-pin connector. If continuity to ground is found, then replace touch pad. If there is no continuity, the switch is bad, the parking brake is not set, or the wires to the switch are bad.
	No signal from ignition	Yellow wire of 6-pin ignition harness must show 12V+ when the key is in the run position. Check and repair wire as necessary.
	Communication error	Purple wire of control panel harness must have 12V+ while any jacks are being extended. Check purple wire for continuity. If no continuity, repair wire or replace harness. If no voltage is found on purple wire, replace touch pad.
	No signal to cube relay from suppression module	With any jack extend switch pushed, terminal 87a of cube relay should show 12V+. If not, check for voltage at terminal "F" of suppression module. If no voltage, replace suppression module.
<b>500629</b> 	All four orange level lights and center green "all level" light are blinking	Coach is parked on an excessive slope. Move coach to a more level area. If coach is already parked on a known level area, then the control box needs calibrated (see TIP sheet # 153).
	Communication error	Blue wire from control box to terminal 87a of cube relay will show 12V+ when any jacks are being extended. Check blue wire for continuity. If no continuity, then repair blue wire or replace harness.



## Any or all jacks will not extend, pump is running

Touch pad #	Probable Cause	Corrective Action
<b>Both</b>	Low fluid level	Fill tank to proper level. See Preventive Maintenance and Recommended Fluids, pg 4.
	The silver, knurled knob on the hand pump is open	Knurled knob must be turned clockwise for normal operation.
	Faulty coil(s)	Check for continuity across the two yellow wires coming out of each of the #1, 2, and 3 coils. If no continuity, replace coil(s).
	Valve coils miswired	Check wiring diagrams.
<b>DN12558</b> 	Communication error	Check for 12V+ on the brown (L & R front), blue (driver side rear), and grey (passenger side rear) wires of the 14-pin control harness while pushing the "all extend" switch. If no 12V+ signal, check the continuity of each of these wires between the touch pad and suppression module. Good wires = bad touch pad. If any of these wires has no continuity, then repair wires or replace harness.
	Faulty suppression module	Check for continuity to ground on terminals H, I, and J. If no continuity on all of these terminals, then check that the black wire from suppression module is connected to good ground. If black wire is connected to ground but there is no continuity to ground on terminals H, I, and J, then replace suppression module.
		Terminals A (passenger side rear jack), B (driver side rear jack), and C (front jacks) transfer the signal from the touch pad to the coils. If no signal is present at these terminals when jack(s) are being extended, replace suppression module.
<b>500629</b> 	Communication error	Check purple (L & R front), yellow (driver side rear), and orange (passenger side rear) wires of the 8-pin coach harness for continuity. Repair wires or replace coach harness as necessary.
		Check that the black wire with white stripe is connected to good ground. Check for continuity to ground on the black wires of the pump harness.
		The purple, yellow, and orange wires of the 8-pin harness will show 12V+ when their respective buttons on the touch pad are depressed. If no signal, replace control box.
	Faulty control	If previous causes and actions do not apply, replace controls



## Jack(s) will not hold pressure

Touch pad #	Probable Cause	Corrective Action
<b>Both</b>	Leaks somewhere in the system	Check all hydraulic hoses for visible leaks. Check that all connections are tight.
		Diagnose and replace as necessary any faulty cylinders. See page 11 for diagnosing suspected cylinders.
	Stem valves are in manual override position	Turn slotted set screws at the end of the valves counterclockwise until they stop. If system has red knobs instead of set screws, turn knobs until they "snap" back into position ( <b>see pg 5</b> ).
	Faulty stem valve	Swap the suspicious valve with one of the other good valves. If the problem follows the valve, change valve.
	Faulty P.O. check valve	Swap the suspicious check valve with a good check valve. If the problem follows the check valve, change check valve.
	Valve coils miswired	Check wiring diagrams.
	Jack(s) leaking	Replace jack or have jack resealed
Bad o-ring in pump assembly	Install o-ring replacement kit #800176 ( <b>see pg 8</b> ).	

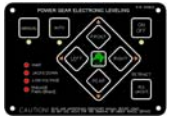
## Jacks will not retract, pump does not run

Touch pad #	Probable Cause	Corrective Action
<b>Both</b>	Bad connection of motor ground wire at pump	Check grounding of black wire coming directly out of 12VDC motor at the pump assembly.
	No power to pump assembly	Check for 12V+ at the pump assembly on the copper buss bar that ties solenoids "A" and "B" together. If power is found, jumper the two large posts on solenoid "A" to see if pump will run. If pump does not run then continue trouble shooting system to isolate problem.
	Motor or pump has failed	Check for continuity between green and black wires of 12VDC motor. If no continuity, replace motor. If continuity is found, then replace pump/motor assembly.
	Solenoid "B" faulty	With any jack retract switch pushed, small post of solenoid "B" should show 12V+. If so, then two large posts of solenoid "B" should have continuity across them. If no continuity, replace solenoid.
<b>DN12558</b> 	Communication error	Orange wire (pin #2) of control panel harness must have 12V+ while any jacks are being retracted. Check orange wire for continuity. If no continuity, repair wire or replace harness. If no voltage is found on pin 2, replace touch pad.
	No signal to solenoid "B" from suppression module	With any jack retract switch pushed, small terminal of solenoid "B" should show 12V+. If not, check for voltage at terminal "E" of suppression module. If no voltage, replace suppression module.
<b>500629</b> 	Communication error	Green wire from control box to small terminal of solenoid "B" will show 12V+ when any jacks are being retracted. Check green wire for continuity. If no continuity, then repair green wire or replace harness.

## Jack(s) will not retract, pump is running

Touch pad #	Probable Cause	Corrective Action
<b>Both</b>	System overfilled with fluid	Drain tank to proper level. See Preventive Maintenance and Recommended Fluids, pg 3.
	Faulty coil(s)	Check for continuity across the two yellow wires coming out of each of the #1, 2, and 3 coils. If no continuity, replace coil(s)
<b>DN12558</b> 	Communication error	Check for 12V+ on the brown (L & R front, pin #5), blue (driver side rear, pin # 8), and grey (passenger side rear, pin #11) wires of the 14-pin control harness while pushing the "all retract" switch. If no 12V+ signal, check the continuity of each of these wires between the touch pad and suppression module. Good wires = bad touch pad. If any of these wires has no continuity, then repair wires or replace harness.
	Faulty suppression module	Terminals A (passenger side rear jack), B (driver side rear jack), and C (front jacks) transfer the signal from the touch pad to the coils. If no 12V+ signal is present at these terminals when jack(s) are being retracted, replace suppression module. Check for continuity to ground on terminals H, I, and J. If no continuity on all of these terminals, then check that the black wire from suppression module is connected to good ground. If black wire is connected to ground but there is no continuity to ground on terminals H, I, and J, then replace suppression module.
<b>500629</b> 	Communication error	Check for 12V+ on the purple (L & R front), yellow (driver side rear), and orange (passenger side rear) wires of the 8-pin coach harness while the "jack retract" button is pressed. If no 12V+ signal, check the continuity of each of these wires between the control box and pump assembly. Good wires = bad control box. If any of these wires has no continuity, then repair wires or replace harness.
		Check that the black wire with white stripe is connected to good ground. Check for continuity to ground on the black wires of the pump harness.
	Faulty control	The purple, yellow, and orange wires of the 8-pin harness will show 12V+ when their respective buttons on the touch pad are depressed. If no signal, replace control box. If previous causes and actions do not apply, replace controls.

## Jacks do not retract completely

Touch pad #	Probable Cause	Corrective Action
Both	Faulty pressure switch	The pressure switch is normally a closed circuit. While jacks are extended, check the green wire w/ black stripe on the pressure switch for continuity to ground. If no continuity, replace switch.

## Jacks retract and pump starts again a few seconds after full retraction

Touch pad #	Probable Cause	Corrective Action
500629 	Faulty control box	Check label on control box for revision number (example: REV 1). Call Power Gear technical service at 800-334-4712 for information regarding current revision to control box.

## “Jacks fully retracted” light does not illuminate

Touch pad #	Probable Cause	Corrective Action
DN12558 	Faulty pressure switch	The pressure switch is normally a closed circuit to ground, but opens when jacks get to complete retraction and the pressure in the manifold builds to over 1400 PSI. With jacks fully retracted and proper pressure in the manifold, green wire w/ black stripe on pressure switch should not have continuity to ground. If continuity to ground is found on green wire with black stripe while jacks are completely retracted and proper manifold pressure is evident, replace pressure switch.
	Communication error	Check green wire(pin #3) of control panel harness for continuity. If no continuity is found, repair wire or replace harness.

## “Jacks down” light does not illuminate

Touch pad #	Probable Cause	Corrective Action
500629 	Communication error	Check that brown wire from control box is connected to green wire w/ black stripe from pressure switch. Reconnect as necessary.
	Faulty pressure switch	The pressure switch is normally a closed circuit to ground. While jacks are extended, check the brown wire of the 8-pin harness at the control box for continuity to ground. If no continuity, replace pressure switch.
	Faulty controls	If previous causes and actions do not apply, replace controls.



## “Jacks down” light does not extinguish

Touch pad #	Probable Cause	Corrective Action
500629 	Communication error	Check that brown wire from control box is connected to green wire w/ black stripe from pressure switch. Reconnect as necessary.
	Faulty pressure switch	The pressure switch is normally a closed circuit, but opens when jacks get to complete retraction and the pressure in the manifold builds to over 1400 PSI. With jacks fully retracted and proper pressure in the manifold, check the brown wire of the 8-pin harness at the control box for continuity to ground. If continuity to ground is found on brown wire while jacks are completely retracted and proper manifold pressure is evident, replace pressure switch.
	Faulty controls	If previous causes and actions do not apply, replace controls.

## “Jacks down” light and alarm will come on while driving, jacks are fully retracted

Touch pad #	Probable Cause	Corrective Action
500629 	Loss of hydraulic pressure at pressure switch	Pressure switch is opened when the jacks are fully retracted and the pressure in the manifold builds to 1400 PSI. Identify any leaks on the retract side of the manifold; including hoses, fittings, and internal piston seals of cylinders.
	Faulty controls	Check label on control box for revision number (example: REV 1). Call Power Gear technical service at 800-334-4712 for information regarding current revision to control box.

## Emergency retract will not function when parking brake is released and/or coach is put into gear

Touch pad #	Probable Cause	Corrective Action
<b>Both</b>	No power to pump assembly	There must be 12V+ at copper buss bar that ties solenoids "A" and "B" together.
	Bad connection of motor ground wire at pump	Check grounding of black wire coming directly out of 12VDC motor at the pump assembly.
<b>DN12558</b> 	Parking brake wire shorted	Pin #3 (white wire with orange stripe) of ignition harness must have continuity to ground when parking brake is engaged. If parking brake is released and continuity to ground is still found, repair white wire with orange stripe or replace ignition harness.
	Ignition wire shorted	Pin #2 (yellow wire) of ignition harness must show 12V+ signal when key is in run position. When key is off, the 12V+ signal should go away. If signal is present while key is off, repair yellow wire or replace ignition harness.
<b>500629</b> 	Improper wiring to 6-pin harness	See Tip Sheets# 195, 196, 197, 199, 200, 204, 205.
	Neutral safety wires shorted	Check for voltage at pin #6 at the 6-pin connector on the control box. If it has 12V+, make sure pin #2 also has 12V+. If pin #6 is ground, try grounding pin #2. If the control then operates, repair or replace wires or neutral safety switch.

## System does not go to correct level position

Touch pad #	Probable Cause	Corrective Action
<b>500629</b> 	Controls need recalibrated	Recalibrate controls according to Tip Sheet # 153.
	Faulty control	If previous causes and actions do not apply, replace controls.

## Touch pad lights are flashing

Touch pad #	Probable Cause	Corrective Action
<b>500629</b> 	Possible trouble code being displayed	See Tip Sheet #184 for error code explanation.

## LIMITED WARRANTY

Power Gear warrants to the original retail purchaser that the product will be free from defects in material and workmanship for a period of (5) years following the retail sales date later than 9-1-05. Labor to repair these components will be covered for two years. Power Gear will, at its option, repair or replace any part covered by this limited warranty which, following examination by Power Gear or its authorized distributors or dealers, is found to be defective under normal use and service. No claims under this warranty will be valid unless Power Gear or its authorized distributor or dealer is notified in writing of such claim prior to the expiration of the warranty period. Warranty is transferable pending documentation of original sale date of product.

### **THIS WARRANTY SHALL NOT APPLY TO:**

- Failure due to normal wear and tear, accident, misuse, abuse, or negligence.
- Products which are modified or altered in a manner not authorized by Power Gear in writing.
- Failure due to misapplication of product.
- Telephone or other communication expenses.
- Living or travel expenses.
- Overtime labor.
- Failures created by improper installation of the product's slideout system or slideout room to include final adjustments made at the plant for proper room extension/retraction; sealing interface between slideout rooms and side walls; synchronization of inner rails; or improper wiring or ground problems.
- Failures created by improper installation of leveling systems, including final adjustments made at the plant, or low fluid level, wiring or ground problems.
- Replacement of normal maintenance items.

There is no other express warranty other than the foregoing warranty. THERE ARE NO IMPLIED WARRANTIES OF MERCHANTABILITY OR FITNESS FOR A PARTICULAR PURPOSE. IN NO EVENT SHALL POWER GEAR BE LIABLE FOR ANY INCIDENTAL OR CONSEQUENTIAL DAMAGES. This warranty gives you specific legal rights, and you may also have other rights, which vary from state to state. Some states do not allow the limitations of implied warranties, or the exclusion of incidental or consequential damages, so the above limitations and exclusions may not apply to you.

For service contact your nearest Power Gear authorized warranty service facility or call 1-800-334-4712. Warranty service can be performed only by a Power Gear authorized service facility. This warranty will not apply to service at any other facility. At the time of requesting warranty service, evidence of original purchase date must be presented.

**Power Gear**  
**1217 E. 7<sup>th</sup> Street**  
**Mishawaka, IN 46544**  
**800/334-4712**  
**[www.powergearus.com](http://www.powergearus.com)**