



**FSD-18A, 21A, & 23A STEERABLE DRIVE AXLE  
SERVICE MANUAL  
625-0518()**

# TABLE OF CONTENTS

<b><u>INTRODUCTION</u></b> .....	<b>1.0</b>
General Description .....	1.1
Operation .....	1.2
Operating Instructions .....	1.3
Specifications .....	1.4
Steerable Drive Axle General Dimensions .....	1.5
<b><u>LUBRICATION</u></b> .....	<b>2.0</b>
Recommended Lubricants.....	2.1
Wheel Bearings .....	2.2
Universal Joints .....	2.3
Kingpin Bearings .....	2.4
Differential Carriers .....	2.5
Steering Tie Rod Ends .....	2.6
<b><u>AXLE ADJUSTMENTS</u></b> .....	<b>3.0</b>
General .....	3.1
Wheel Bearing Adjustment .....	3.2
Kingpin Adjustment .....	3.3
Toe-In Adjustment .....	3.4
Steering Stop Adjustment .....	3.5
Camber Adjustment .....	3.6
Brake Adjustment .....	3.7
<b><u>STEERABLE DRIVE END DISASSEMBLY</u></b> .....	<b>4.0</b>
General Precautions for Disassembly .....	4.1
Brake Drum, Hub, and Wheel Bearings .....	4.2
Brake and Wheel Spindle .....	4.3
Spindle Yoke Removal .....	4.4
<b><u>CLEANING AND INSPECTION</u></b> .....	<b>5.0</b>
Choice of Cleaning Methods .....	5.1
Drying and Corrosion Inhibition .....	5.2
Inspection .....	5.3
<b><u>STEERABLE DRIVE END ASSEMBLY</u></b> .....	<b>6.0</b>
General Precautions for Assembly .....	6.1
Spindle Installation .....	6.2
Brake Equipment .....	6.3
Wheel Bearings, Hub, and Brake Drum .....	6.4

# TABLE OF CONTENTS

<b><u>ADDITIONAL SERVICE PROCEDURES</u></b> .....	<b>7.0</b>
Steerable Drive End Removal .....	7.1
Differential Carrier Removal .....	7.2
<b><u>TORQUE SCIFICATIONS</u></b> .....	<b>8.0</b>
<b><u>SPECIAL TOOLS</u></b> .....	<b>9.0</b>
Wheel End Inner Seal Driver .....	9.1
Wheel Hub Seal Driver .....	9.2
Lower Kingpin Seal Driver .....	9.3
Lower Kingpin Bearing Driver .....	9.4
Upper Kingpin Seal Driver .....	9.5
Upper Kingpin Bearing Driver .....	9.6
Inner Axle Seal Driver .....	9.7
Upper Kingpin Ball Stud Puller .....	9.8
Camshaft Seal Driver (Brake Bracket) .....	9.9
Camshaft Bushing Driver (Brake Bracket) .....	9.10
Camshaft Seal Driver (Spindle Yoke) .....	9.11
Camshaft Bushing Driver (Spindle Yoke) .....	9.12
Steerable End Removal Tool .....	9.13
Lower Kingpin Locknut Tool .....	9.14
Lower Kingpin Ball Stud Removal Tool .....	9.15
Hub Bearing Lock Nut Tool .....	9.16
<b><u>ILLUSTRATED PARTS AND LIST</u></b> .....	<b>SEE PARTS MANUAL</b>

## 1.0 INTRODUCTION

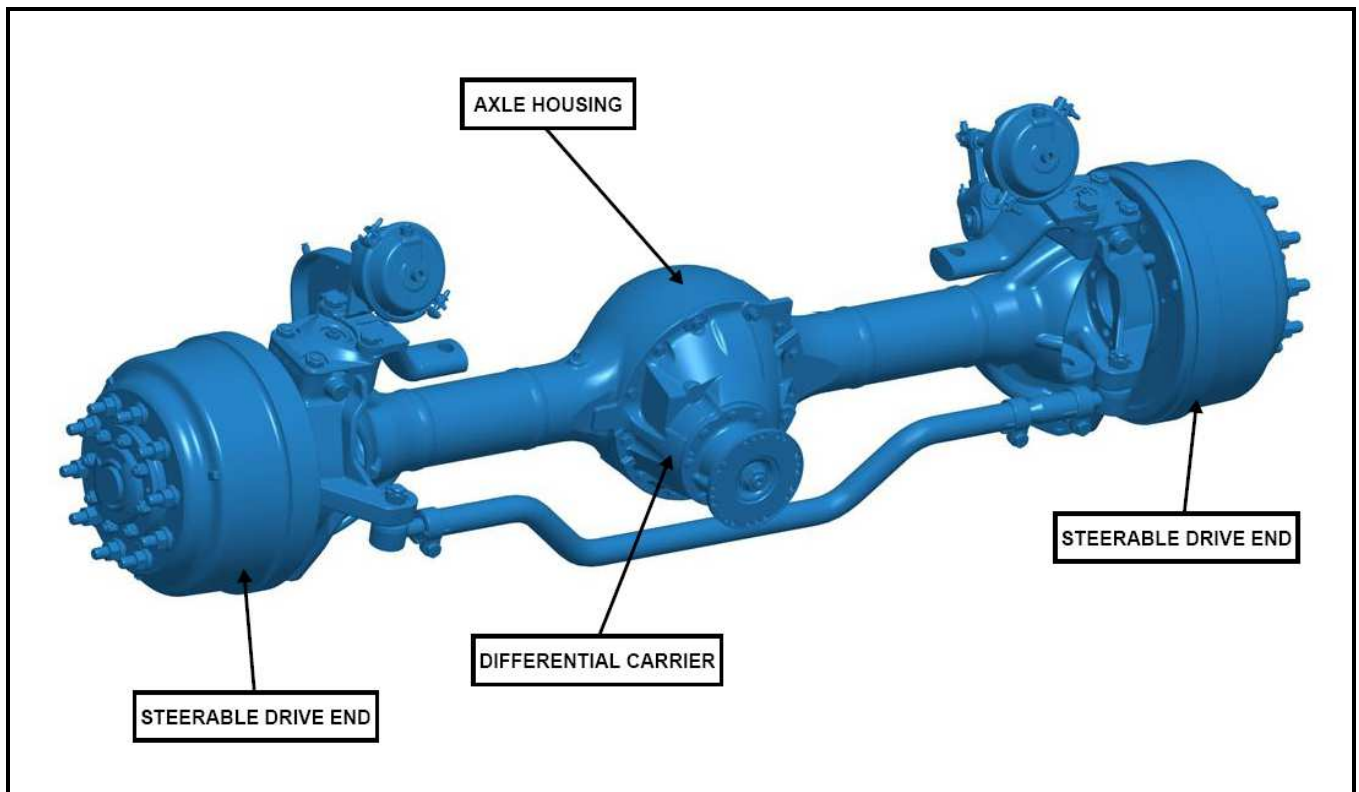

### 1.1 GENERAL DESCRIPTION

The Fabco Steerable Drive Axle consists of four major assemblies; the axle housing, two steerable drive ends, and a differential carrier. A steering tie rod links the right and left steerable ends, and steering in put is delivered via a steering arm. The steering arm is usually located on the left steerable end, although right hand or even dual steering arms are available.

### 1.2 OPERATION

Driving forces are put into the axle at the pinion yoke on the differential carrier; they pass through the differential to the inner axle shafts and on to the universal joints. The yoke shafts get their power from the U- joints and transfer it by means of splines to the drive flanges, which are bolted to the wheel hubs, thus rotating the wheels.

When steered, the outer section of each steerable drive end rotates about the kingpin center line. The U- joint, centered on the kingpin centerline, allows power to be

transmitted through out the possible range of steering in puts.

The axle is equipped with S-cam air brakes and automatic slack adjusters.

### 1.3 OPERATING INSTRUCTIONS

In conditions where the vehicle's rear wheels might spin, such as sand, loose dirt, mud, snow, ice, or ascending grades, the front drive axle can be shifted into operation for improved traction. Engagement can be made at any vehicle speed, provided that the rear wheels are not spinning. Engagement is best accomplished when the engine is pulling lightly.

### NOTES

## 1.4 STEERABLE DRIVE AXLE SPECIFICATIONS - FABCO MODEL FSD-18A, 21A, & 23A

The Fabco Model FSD-23A Steerable Drive Axle is an exposed Cardan joint design developed for use on-highway with rough terrain capability. This is a low profile axle, which packages similar to a hub reduction design, but is of North American design and manufacture. The axle utilizes the decades-proven Fabco design philosophy of light weight and strong fabricated steel design, spherical king pins for excellent steering performance and easy maintenance.

<b>Nominal Capacity</b>	18,000, 21,000 & 23,000-lb.
<b>Brakes</b>	
Type	Drum, S-cam
Size	16.5-Inch Diameter x 7-Inch
Chamber	30-Inch <sup>2</sup>
Certification	FMVSS 121
Slack Adjuster	Automatic, Gunite Standard
<b>Housing</b>	Fabricated Steel, Cast Banjo, Center Bowl
<b>Camber</b>	1/2° Positive
<b>Wheels</b>	
Mounting	10-Studs on 285.75-mm Hub Piloted Standard
Minimum Wheel Size	20-Inch
<b>Differential Carrier Ring Gear Diameter</b>	14.5-Inch Hypoid
<b>Single Reduction Ratios</b>	3.31, 3.73, 4.10, 4.56, 4.88, 5.13, 5.71, 6.33
<b>Universal Joint</b>	Single Cardan, Permanently Lubricated
<b>Steering</b>	Ackerman to Match Wheelbases Dual Steering Arms
<b>Kingpins</b>	
Type	Spherical, Nylatron Races
Inclination	5°
<b>Track</b>	95.0-Inch Over Wheel Mounts Standard
<b>Turn Angle</b>	
Type	35°
<b>Lubrication</b>	
Type	SAE 75-90, 80W-140 GL5
<b>Weight-Dry</b>	1,800-lb.

# 1.5 STEERABLE DRIVE AXLE GENERAL DIMENSIONS

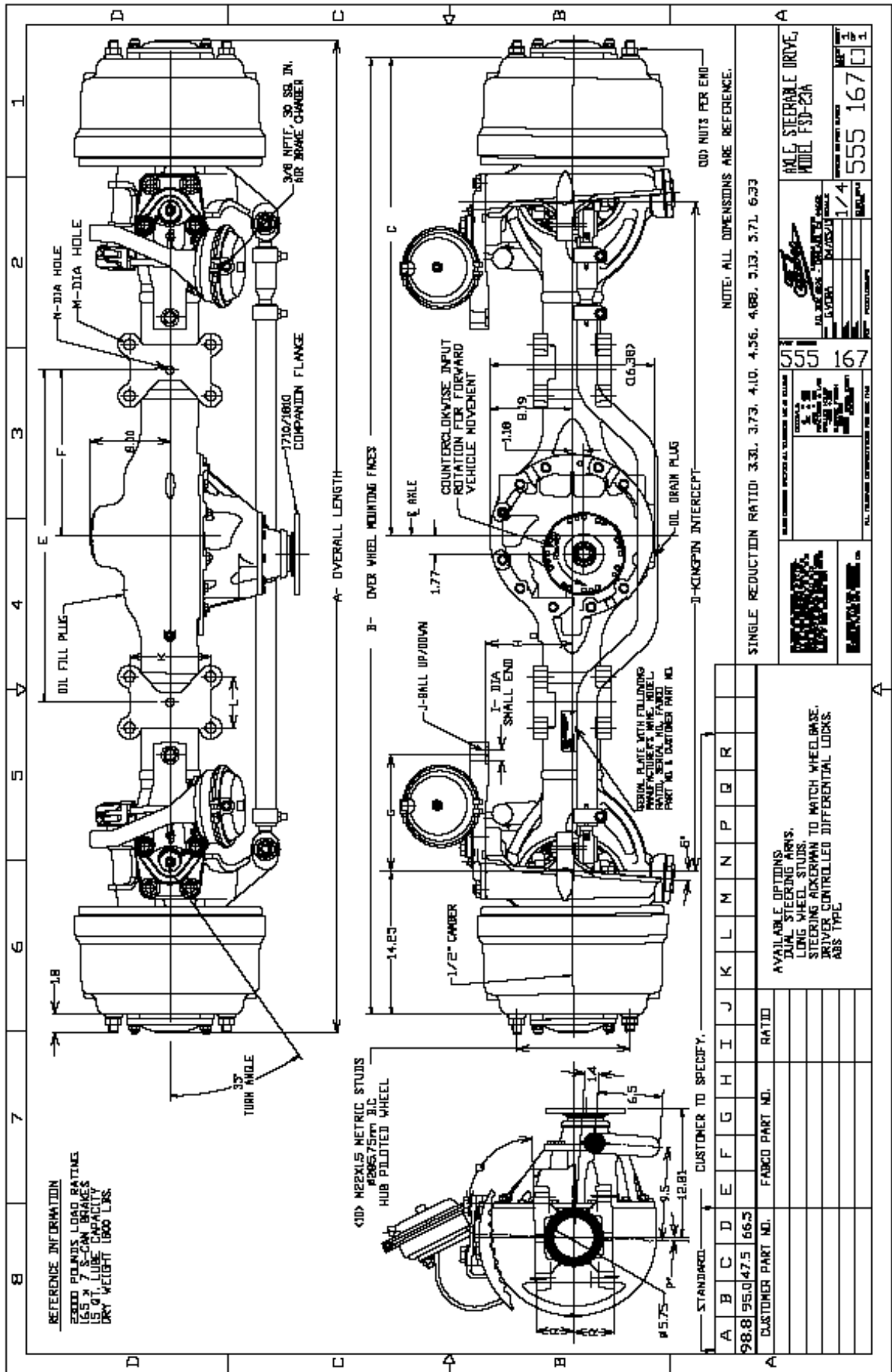

## 2.0 LUBRICATION

### 2.1 RECOMMENDED LUBRICANTS

#### 1. Gear Oil:

<u>Temperature</u>	<u>Grade</u>
-40°F to 100°F (-40°C to 38°C)	SAE 75W-90 GL5
-15°F to 120°F (-26°C to 49°C)	SAE 80W-140 GL5

#### 2. Chassis Grease:

<u>Temperature</u>	<u>Grade</u>
Above 32°F (0°C)	MIL-G-10294
Below 32°F (0°C)	MIL-G-10294

#### 3. Wheel Bearing Grease:

<u>Temperature</u>	<u>Grade</u>
Above 32°F (0°C)	NLGI Grade #2
Below 32°F (0°C)	NLGI Grade #2

### 2.2 WHEEL BEARINGS

Wheel bearings require cleaning, inspection, and packing with grease at each brake reline. Wheel bearings should be lubricated in accordance with the vehicle manufacturer's recommendations. When greasing, liberally pack both inner and outer bearings, ensuring that the grease has penetrated thoroughly into the cage and roller assembly. Prior to reassembly, coat the race ways and interior hub surfaces as well.

### 2.3 UNIVERSAL JOINT

Universal joints are lubricated and sealed at the factory, and should require no additional maintenance throughout their service life.

### 2.4 KINGPIN BEARINGS

Kingpin bearings should be lubricated at each chassis lubrication (approximately 1,000 mile intervals). To ensure thorough lubrication, the front axle should be raised slightly to relieve vehicle weight. The lower king pin lube fitting is located at the bottom of the lower kingpin ball

stud itself. The upper kingpin fitting is on the steering arm or upper kingpin cap.

### 2.5 DIFFERENTIAL CARRIERS

Differential carriers should have the lubricant changed at the same interval as the rear axle on the vehicle, or approximately 10,000 miles. Drain while lubricant is warm and clean the magnetic drain plug. Removal of the fill plug will allow quicker drainage. Be sure to allow the housing to drain completely. Reinstall the drain plug and fill the housing to the bottom of the fill plug with the appropriate gear oil. Check for leaks. SAE 140 gear oil (meeting MIL- L-2105 B) is appropriate for most operating conditions. For extreme conditions, follow the vehicle manufacturers recommendations for the rear axle and apply them to the front axle.

### 2.6 STEERING TIE ROD ENDS

Tie rod ends should be lubricated every 1,000 miles at each chassis lubrication. Inspect for loose, bent, or other wise damaged components. Careful attention to such detail is a vital safety factor.

### NOTES



## 3.0 AXLE ADJUSTMENT

### 3.1 GENERAL

Adjustments may be necessary after an accident, in response to or to correct steering problems, tire wear problems, or as part of the reassembly process after a thorough inspection.

### 3.2 WHEEL BEARING ADJUSTMENT

1. The front of the vehicle should be raised, properly supported, and the front wheels removed from the axle.
2. Then remove the brake drum.
3. Remove the eight 5/8" outer drive flange locknuts.
4. The drive flange should be loose enough to remove by hand. If it is not, use two 1/2"-20 bolts in the extractor holes provided for this purpose. See **Figure 1**.

**Figure 1**

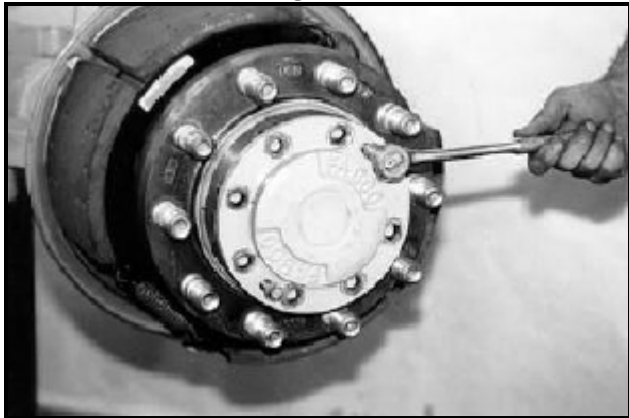

5. Remove the wheel bearing locknut and washer from the spindle and loosen the bearing adjusting nut.
6. Torque the bearing adjusting nut to 50 lb.-ft. while simultaneously rotating the hub assembly. (See Section Special Tools 9.16.) Loosen the nut and repeat this procedure 2-3 times to ensure that the bearings are seated properly. After the final tightening, back off the nut 1/4 turn. See **Figure 2**.

**Figure 2**

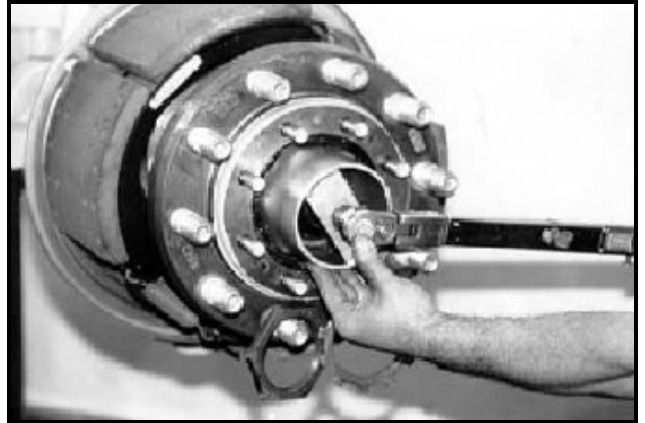

7. Install the wheel bearing lock washer and wheel bearing adjustment nut, then torque locknut to 400 lb.-ft. (See Section Special Tools 9.16.) Next, one tab on the lock washer should be bent inward and one bent outward across the flat test part of the nut.

**NOTE:** WITH THE OUTER LOCKNUT TORQUED TO SPECIFICATIONS THE WHEEL HUB SHOULD ROTATE FREELY.

8. The wheel bearing end play should be checked with a dial indicator as part of the adjustment procedure. See **Figure 3**. The correct end play setting is no less than .002" and no more than .004".

**Figure 3**

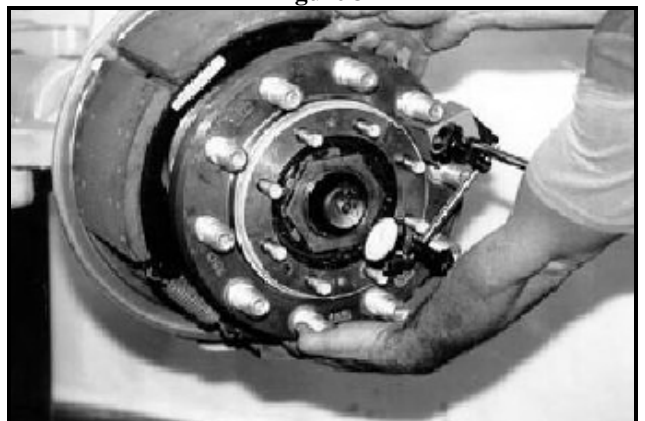

9. Reinstall the drive flange over the hub assembly. Then torque the drive flange locknuts to 175 lb.- ft.



### 3.3 KINGPIN ADJUSTMENT

1. The front of the vehicle should be raised, properly supported, and the front wheels removed from the axle.
2. Loosen the lower king pin locknut (see Section 9.14 Special Tools) and back it down enough to allow the lower king pin lock washer to disengage from its retaining dowel pin. Remove the grease fitting. Back the lower king pin ball stud (see Section 9.15 Special Tools) down four complete turns.
3. Loosen the upper king pin adjustment jam nut and back out the adjusting screw four full turns. The drive end assembly will begin to lower as the screw is turned out. See **Figure 4**.

**Figure 4**

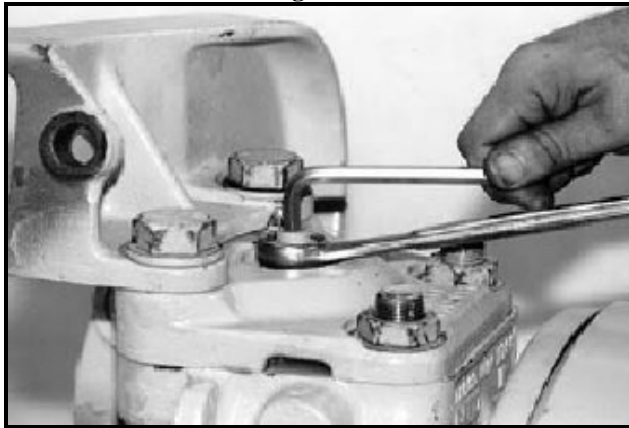

4. Begin tightening the adjusting screw and continue until upward motion of the steerable end stops. If a finger is placed near the gap between the suspension and spindle yokes, the point at which upward travel stops can be readily felt. Additional resistance will also be felt in the effort required to turn the adjusting screw. The upper kingpin has now been seated in its bushing.
5. Place a stack of feeler gages or drift in the gap between the suspension and spindle yokes in the area of the lower king pin ball stud. The gages or drift should fit snugly. Filling the gap. No measurement is necessary. See **Figure 6**.

**Figure 5**



6. Advance the lower kingpin ball stud until the feeler gage stack or drift loosens. (See Section Special Tools 9.15.) This indicates that the ball stud threads are actually beginning to spread the suspension and spindle yokes apart. See **Figure 6**.

**Figure 6**

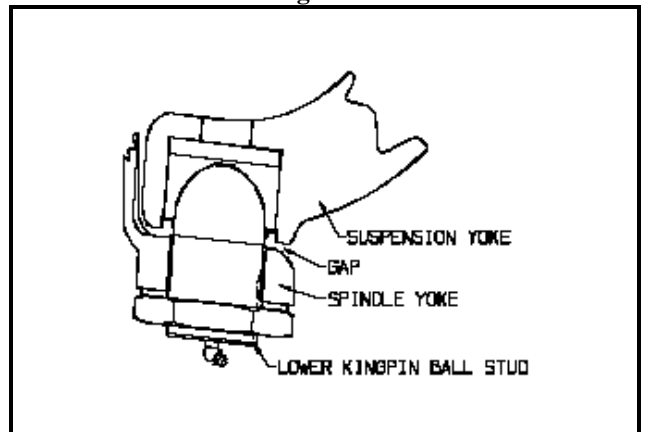

7. Back off the ball stud enough to allow the closest hole in the lower kingpin lock washer to engage the retaining dowel pin. Apply grease to the surface of the lower kingpin lock washer that will face the locknut. This helps keep the washer from turning when the locknut is tightened. **Torque the locknut to 2,000 lb.-ft.** (See Section Special Tools 9.14).

**CAUTION: DO NOT TORQUE LOWER KINGPIN BALL STUD.**

Back out the upper kingpin adjusting screw just enough to relieve pressure so the end can turn freely (approximately 1/16 turn) and torque the jam nut to **75 lb.-ft.**

### 3.4 TOE-IN ADJUSTMENT

It is not recommended to raise the front of the truck to check toe-in; at the factory, the setting is made with the axle loaded to simulate actual operating conditions. An expandable toe-in alignment bar is recommended but if unavailable consult an alignment specialist. Since the FSD-18A, 21A, and 23A axles use an off set tie rod tube, adjustment is not made by turning the tube itself, but rather by rotating a small adjuster located at the left or right end of the tie rod tube. See **Figure 7**. It is critical to making the adjustment accurately that the front wheels are as close to straight ahead as possible. Loosen the tie rod adjuster and tie rod clamp.

**Figure 7**

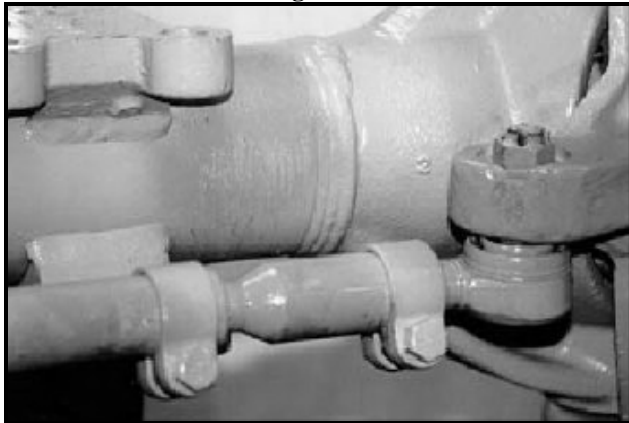

1. Which ever end the tie rod adjuster is located toe-in is increased by unscrewing the adjuster from the tie rod itself. The correct setting is 0-1/8" toe-in. In the case of a vehicle with fulltime four-wheel drive (proportioning differential), the setting reverts to 0-1/8" toe-out (greater distance in the front than the rear). Consult a tire specialist for a specific recommendation if specialized tires are used.
2. Tighten both clamp bolts to **75 lb.-ft.** Roll the vehicle forward a distance equal to four rotations of the wheels, taking care to maintain their straight-ahead alignment. Recheck the toe-in and repeat this procedure if necessary to obtain the correct dimension.

### 3.5 STEERING STOP ADJUSTMENT

The steering stop adjustment is made at the factory. There should be no need to alter it, unless a major component such as the axle housing or spindle yoke has been replaced for some reason. The turn angle is set at 35°, and this can be checked with a carpenter's power saw protractor on the wheel's inside rim and a T-square laid along the frame rail with the vehicle's steering at full lock. If an adjustment is necessary, loosen the steering stop 12-point adjusting screw on the rear of the spindle yoke and add or remove washers to achieve desired turn angle. Torque the jam nut to **75 lb.-ft.** The toe-in adjustment (Section 3.4) should be completed before performing this procedure.

**WARNING: THE POWER STEERING GEAR'S PRESSURE RELIEF SHOULD OCCUR AT LEAST 1/8" BEFORE THE AXLE STEERING STOPS ARE CONTACTED. IF THE POWER STEERING PRESSURE RELIEF NEEDS ADJUSTMENT CONSULT WITH THE VEHICLE'S MANUFACTURER BEFORE OPERATING THE VEHICLE. FAILURE TO COMPLY CAN RESULT IN DAMAGE TO THE STEERABLE DRIVE AXLE AND OTHER STEERING COMPONENTS.**

### 3.6 CAMBER ADJUSTMENT

Caster is specified by the vehicle manufacturer and can be adjusted only by means of shims between the axle spring seat and the spring. Changing the caster will change the pinion angle and may affect the operation of the front drive shaft.

### 3.6 BRAKE ADJUSTMENT

After an initial setup procedure, brake adjustment is made automatically by the slack adjusters, and should require no attention between relines. To adjust the slack after a brake reline:

1. Using a 7/16" socket, rotate the hex extension on the front of the slack adjuster clockwise until the shoes first contact the drum. See **Figure 8**. Rotate the hex extension 1/2 turn counter-clockwise to back off the shoes and provide initial running clearance. A ratcheting noise while backing off is normal.

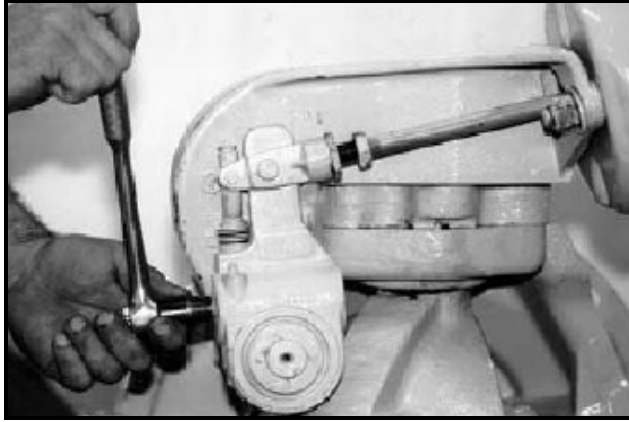
**Figure 8**

2. Confirm that the drum rotates freely. Scraping noises are OK, but no heavy drag should exist. If excessive friction is present, continue to back off the hex extension in 1/8 turn increments until free motion is restored.

**NOTE:** IT IS PREFERABLE TO HAVE A SLIGHTLY LOOSE INITIAL SETTING THAN ONE THAT IS TOO TIGHT. THE ADJUSTER WILL REMOVE EXTRA SLACK, BUT CANNOT ADD ANY.

**NOTES**

## 4.0 STEERABLE DRIVE END DISASSEMBLY

### 4.1 GENERAL PRECAUTION FOR DISASSEMBLY

**CAUTION:** READ THIS SECTION BEFORE STARTING THE DISASSEMBLY PROCEDURES.

1. Follow each procedure closely in each section, making use of both text and figures.
2. The outside of the unit should be carefully cleaned before starting disassembly. If steam cleaning, ensure that breather and air fittings are covered to prevent moisture from entering the assembly.
3. Prepare a clean place to work. It is important that no dirt or foreign material be allowed to enter the unit during repairs.
4. Refer to the exploded views located in the parts manual as an aid in disassembly.
5. When disassembling the various assemblies, lay all parts on a clean bench in the same sequence as removed. This procedure will simplify reassembly and reduce the possibility of losing parts.
6. Carefully wash and relubricate all bearings as removed, and protectively wrap until ready for use. Remove bearings with pullers designed for this purpose, or in a manner which will not damage those bearings that will be reused.
7. When necessary to apply force to remove a part, the use of a puller or press is preferred. In some cases, the use of a bar or soft hammer may be allowable.

### 4.2 BRAKE DRUM, HUB, AND WHEEL BEARINGS

1. Raise the front of the vehicle with a jack and secure with jack stands of suitable capacity. Also remove the front wheels.
2. Remove the brake drums.

**WARNING:** WHEN REMOVING THE BRAKE DRUMS TAKE SUITABLE PRECAUTIONS IF THE POSSIBILITY OF EXPOSURE TO ASBESTOS DUST EXIST. FABCO ORIGINAL EQUIPMENT BRAKE SHOES ARE NOT ASBESTOS BASED.

3. Remove the eight 5/8" outer drive flange locknuts.
4. The drive flange should be loose enough to remove by hand. If it is not, use two 1/2"-20 bolts in the extractor holes provided for this purpose. See **Figure 9**.

**Figure 9**

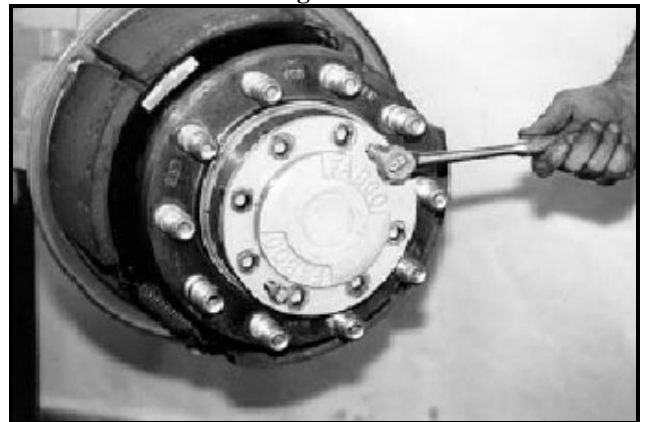

5. Remove the wheel bearing locknut, washer, and adjusting nut from the spindle. Rock the hub in place to loosen the outer wheel bearing cone. Remove the cone and wrap it protectively.
6. Remove the hub, initially attempting to pull the assembly straight off to avoid cocking the inner bearing cone. See **Figure 10**. If the cone binds against the spindle try rocking the hub to free it, but it may be necessary to use a pry bar under the inner surface of the hub. (To avoid damaging the inner seal, pry against the hub only.) If the inner bearing remains on the spindle when the hub is removed, use a suitable puller to remove it, pulling only against the bearing's race. Alternately, tap lightly on the race's out board surface with a small drift to correct its misalignment and again attempt to remove it by hand.

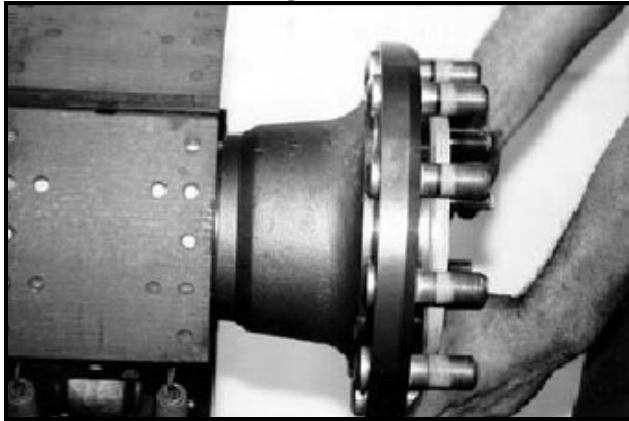
**Figure 10**

7. Wheel bearing cups may be removed from the hub using a suit-able puller. Pull the cup out evenly.

**NOTE: THIS IS THE LIMIT OF ROUTINE DISASSEMBLY. BRAKE SHOES AND WHEEL BEARINGS MAY BE ACCESSED FOR MAINTENANCE, BUT FURTHER DISASSEMBLY MAY BE REQUIRED TO REPLACE DAMAGED OR BROKEN PARTS.**

#### 4.3 BRAKE AND WHEEL SPINDLE

1. Removal of the brake shoes will be facilitated by turning out the 7/16" adjustment screw on the slack adjuster to relieve tension on the S-cam rollers. See **Figure 11**. Turn the screw counter-clockwise until the rollers rest at the lowest point on the cam.

**Figure 11**

2. Insert a suitable pry bar down between the top of the brake shoe and a spindle locknut. Pry the shoe away from the S-cam and remove the roller. Relax the spring tension, then remove the opposite roller in like fashion. See **Figure 12**.

**WARNING: DO NOT ALLOW OUR FINGERS TO COME DIRECTLY BETWEEN THE SHOE AND THE S-CAM!**

**Figure 12**

3. Next, remove the push rod from the slack adjuster clevis by loosening the locknut. See **Figure 13**.

**Figure 13**

4. To remove the S-camshaft pry the retaining snap ring, located on the slack adjuster end of the S-camshaft, out of its groove then pull the S-camshaft out of the air chamber mounting bracket. At the same time remove the shims, slack adjuster, and the washer located between the slack adjuster and air chamber bracket.
5. To remove the brake shoes detach the top retaining spring from the lower shoe. Then with shoe in hand lower down to detach the release springs at the anchor pins. Now the other brake shoe is free to be removed.



6. Remove the two 5/8" air chamber mounting nuts and washers to detach the chamber from the mounting bracket. The mounting bracket itself can be withdrawn from the spindle yoke following removal of its two 7/8" mounting bolts.
7. Remove the ten 3/4" self locking nuts which secure the spindle. A little persuasion with a soft mallet may be necessary to free up these components. See **Figure 14**.

**Figure 14**

#### 4.4 SPINDLE YOKE REMOVAL

1. Due to its high torque, loosening the 4 1/8" lower kingpin locknut (see Section 9.14 Special Tools) will require substantial leverage. Remove the grease fitting from the lower kingpin ball stud. Now the ball stud can be removed. (See Section 9.15 Special Tools.) See **Figure 15**.

**Figure 15**

2. Remove the cotter pins from both tie rod ends. Unscrew both castle nuts so that

only a few threads remain in engagement. Use a suitable puller to extract the tie rod end from the suspension yoke. Completely remove the nuts and tie rod.

**WARNING:** DO NOT STRIKE THE TIE ROD END BALL STUD.

3. Loosen the upper kingpin adjusting screw jam nut and back out the adjusting screw until the spindle yoke stops moving downward and is resting on the suspension yoke. Remove the two 7/8" steering arm or upper kingpin cap locknuts and bolts. Then pull the steering arm or cap up and off the mounting studs and locating dowel. If difficulty is encountered, turn the adjusting screw back in to force the arm or cap off the studs. See **Figure 16**.

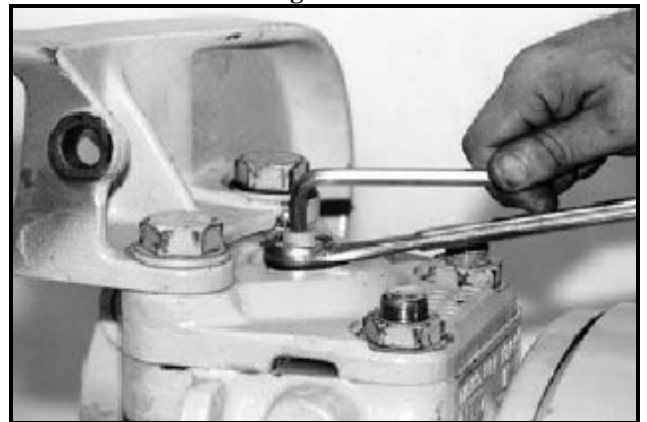
**Figure 16**

4. Remove the drive yoke bearing retaining snap ring and thrust washer. The yoke shaft bearing removal is optional. Remember to repack the bearing upon installation.
5. Remove the 1"-14 upper kingpin bolt. Special tool number 866-0744 (see Section 9.8 Special Tools) should now be used to pull the upper kingpin ball stud from the suspension yoke. See **Figure 17**. Fit one tube over the locating dowel and the other is allowed to float freely. Insert the 1 1/8"-12 bolt through the spacer and the tool's central hole. The bolt should then be threaded into the top of the upper kingpin ball stud. Tighten the bolt until the ball stud is pulled free of the suspension yoke.

Remove the tool, grasp the spindle yoke firmly and disengage it from the suspension yoke. An overhead crane would make this procedure a lot easier.

Figure 17

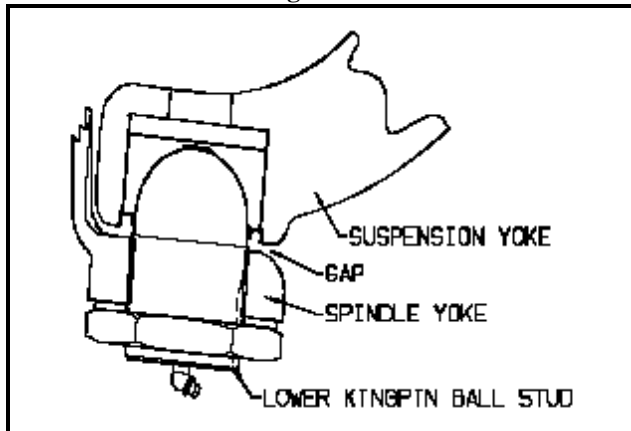

**CAUTION:** DO NOT TRY TO REMOVE THE UPPER KINGPIN BALL STUD BY ROCKING THE SPINDLE YOKE, AS THIS MAY AFFECT THE CRITICAL PRESS FIT BETWEEN THE BALL STUD AND SUSPENSION YOKE.

**CAUTION:** DO NOT PROCEED FURTHER UNLESS THE DIFFERENTIAL OIL HAS BEEN DRAINED.

- Remove the drive and axle shaft assemblies by sliding them out of the axle housing being very careful not to score the inner axle seal. See **Figure 18**. No need to take this assembly apart unless replacing the cross and bearing.

Figure 18

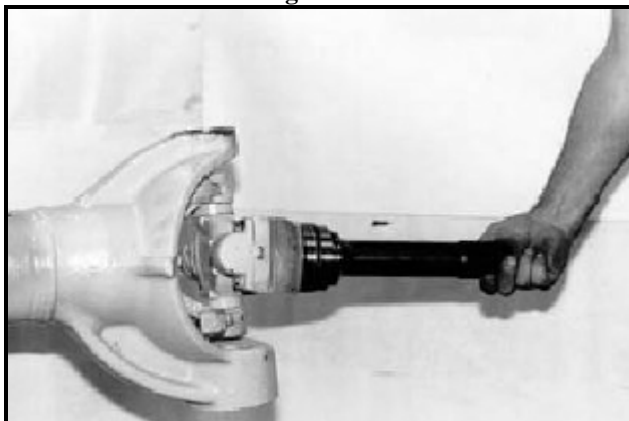

- Remove the lower kingpin bearing and seal from the suspension yoke by inserting a 7/8" or smaller flat-headed bar through the upper kingpin bolt hole so it contacts the lower kingpin plate. See **Figure 19**. Strike the top of the bar to drive out the bearing. Do not remove

the upper kingpin bearing from the spindle yoke unless it has been determined that replacement is necessary. The upper bearing may be driven out by the bottom of its inside edge using a chisel or drift.

Figure 19



## NOTES

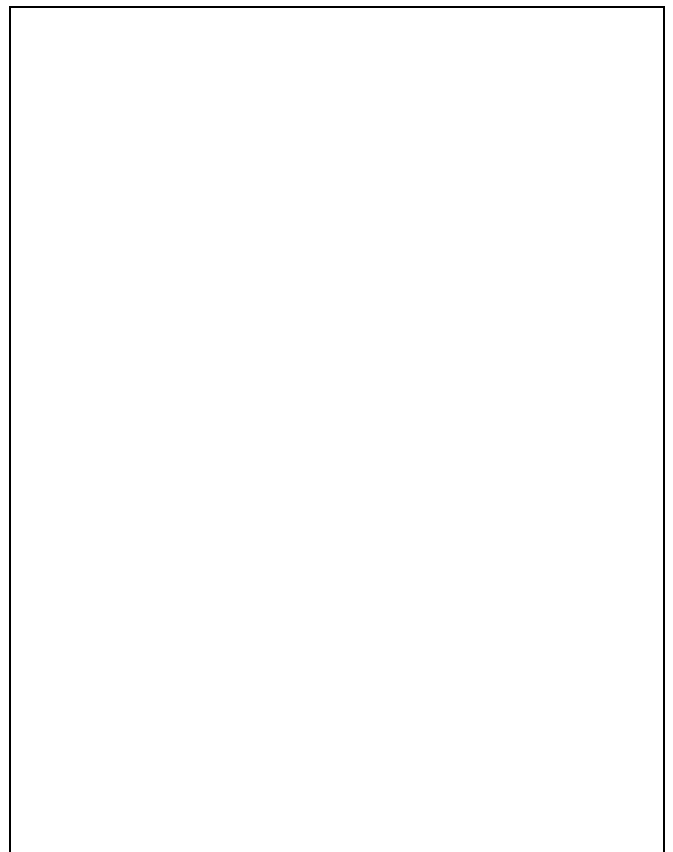



## **5.0 STEERABLE DRIVE END DISASSEMBLY**

### **5.1 CHOICE OF CLEANING MEATHODS**

1. Steam may be used for external cleaning of completely assembled units. Care must be taken to ensure that water is kept out of the assembly by tightly closing breather caps and other openings.
2. Rough parts such as housings, which are too large to conveniently clean with solvents, may be immersed in a hot solution tank containing a mild alkaline solution. Parts cleaned in hot solution tanks must be rinsed thoroughly to prevent damage by traces of alkaline material.
3. Parts with ground or polished surfaces, such as bearings or shafts, should be cleaned with emulsion cleaners or petroleum solvents. Alkaline hot solution tanks may damage the machined surfaces and should be avoided.

### **5.2 DRYING AND CORROSION INHIBITION**

Soft clean shop towels should be used to dry parts after cleaning. Compressed air may be used to clean accessible areas of large parts such as the housing. Bearings should not be spun dry with compressed air as the lack of lubrication may cause damage to the mating surfaces.

Dry parts should be immediately coated with a light oil or a corrosion inhibitor to prevent corrosion damage. Parts which are to be stored should also be wrapped in heavy waxed paper.

### **5.3 INSPECTION**

Prior to reassembly, parts which are to be re used must be care fully inspected for signs of wear or damage. Replacement of such parts can prevent costly down time at a future date.

All bearing and bushing surfaces including roller bearing cups and cones should be examined for pitting, wear, or over heating. Shafts may be nicked and marred or have damaged threads. Inspect all structural members and welds closely for any signs of cracking. Parts which

show any sign of damage should be repaired or replaced.

### **NOTES**

--

## 6.0 STEERABLE DRIVE END ASSEMBLY

### 6.1 GENERAL PRECAUTIONS FOR ASSEMBLY

#### 1. Assembly:

Refer to the exploded views located in the parts manual as an aid to assembly.

#### 2. Initial Lubrication:

Splines and grease seal lips should be coated and filled with grease prior to reassembly to provide lubrication upon start up.

#### 3. Bearings:

Use of flanged-end bearing drivers is recommended for the installation of bearings and races. These drivers only apply force to the races of the bearing, preventing damage and maintaining alignment with the shaft and bore.

#### 4. Seals:

Use a flanged type guide or driver to install seals. If a driver is not available, use of a soft hammer and/or wood blocks may be made, provided that care is exercised. Proprietary drivers are available directly from Fabco and drawings are also provided in Section 9.

### 6.2 SPINDLE INSTALLATION

1. If the inner axle seal has been removed, smear grease on the inner bushing surface of the replacement part and apply a thin bead of Loctite gasket eliminator to the outer surface. Drive it into the suspension yoke until it seats squarely against the shoulder of the bore.

**CAUTION:** THE BRONZE INNER BUSHING SURFACE HAS AN OIL PASSAGE WHICH SHOULD BE LOCATED AT 3 OR 9 O'CLOCK BEFORE THE SEAL IS DRIVEN IN.

2. Place the lower kingpin plate in the suspension yoke and drive in the bearing and seal after it. See **Figure 20**. Both upper and lower kingpin seals must be installed in their bores w/grease

lips facing outward. If the upper kingpin bearing has been removed, install the new part using either a pusher plate or the old part as a driver. See **Figure 21**. If necessary, install a new upper kingpin seal against its shoulder opposite the upper kingpin bearing.

**Figure 20**

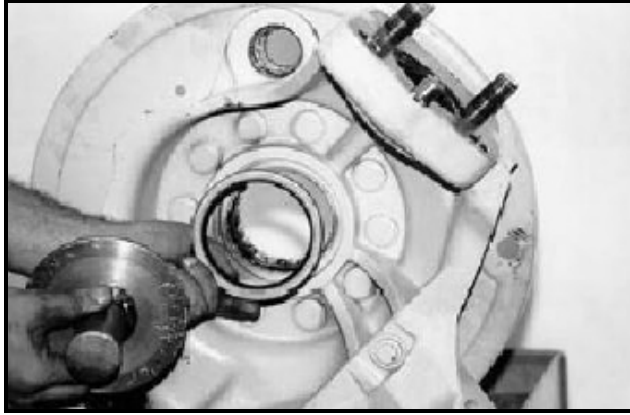

**Figure 21**



3. If necessary, install a new wheel end inner seal. See **Figure 22**. Grease lightly all seal lips and kingpin bearings.
4. Reinstall the drive axle shaft assemblies being careful not to score the inner axle seal.

Figure 22



5. Place the spindle yoke on the suspension yoke, optimally with some lifting device. See **Figure 23**. Install the upper kingpin ball stud and bolt. It is recommended to replace the bolt with a new one from Fabco. If a replacement bolt is not available, use the existing bolt and apply Loctite #272 to its threads during assembly. Torque the bolt to 1,000 lb.-ft.

Figure 23

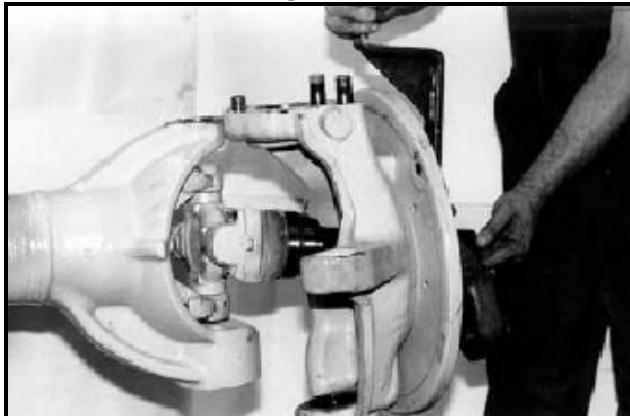

6. Reinstall the yoke shaft bearing, if removed, making sure it is packed liberally with grease. See **Figure 24**. Replace the thrust washer and snap ring.

Figure 24

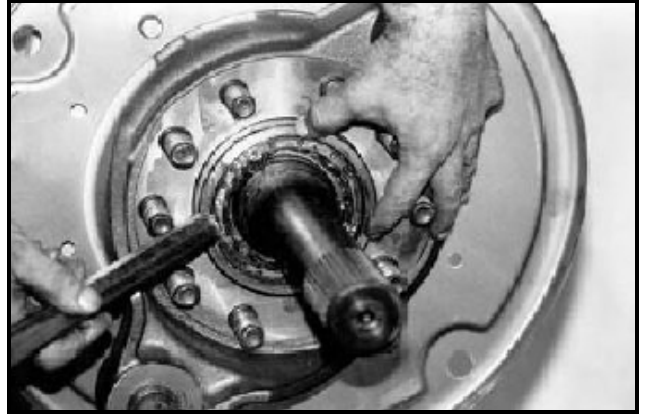

7. Smear the spherical portion of the lower kingpin ball stud with grease. Screw the lower kingpin ball stud into the spindle yoke. Ensure that the locating pin for the kingpin lock washer is in position in the yoke, then loosely install the lock washer and nut.
8. After wiping both mounting surfaces clean of grease, push the steering arm or upper kingpin cap down over its mounting studs and pilot dowel, install the two 3/4" nuts, and torque to **250 lb.-ft.** Install the upper kingpin adjusting screw, its jam nut, and the lubrication fitting in the cap or arm.
9. Complete steps 4-7 of Section 3.3 (Kingpin Adjustment) in this manual.
10. Install the spindle over the yoke shaft and spindle yoke studs. See **Figure 25**. Torque the spindle nuts to **250 lb.-ft.** using a uniformed torque sequence.

**CAUTION: THE KEYWAY MUST BE LOCATED IN THE 12 O'CLOCK POSITION.**

Figure 25

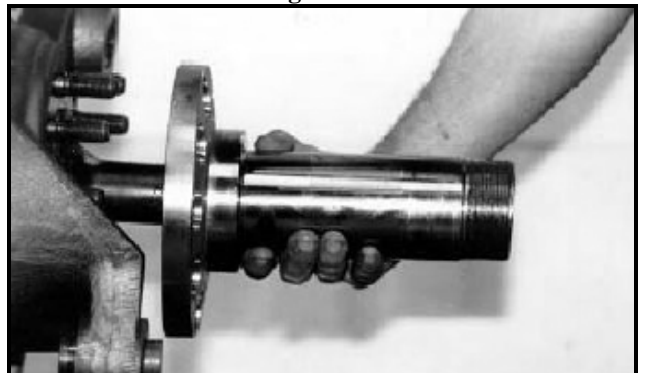

11. Reinstall the tie rod end, torque the castle nut to **100 lb.-ft.**, and fit a new cotter pin.

### 6.3 BRAKE EQUIPMENT

1. If necessary, press new seals and bushings into the air chamber mounting bracket and spindle yoke. Seals must be installed flush so that the lip side (with spring) of both seals face to ward the slack adjuster end of the bracket. Improperly oriented seals may allow grease to exit the cam shaft head end and contaminate the brake linings.

**CAUTION: THE CAM HEAD END BUSHING SHOULD BE RECESSED 5/16" TO ALLOW CLEARANCE FOR THE SEAL. THE BRAKE BRACKET BUSHING SHOULD BE RECESSED 23/32" TO ALLOW CLEARANCE FOR THE SEAL.**

2. Push the S-camshaft all the way into the mounting bracket from the wheel side until the cam head contacts the bracket. Next, push the camshaft tube onto the shaft. Make sure that the O-rings are set in the grooves on the camshaft tube.

**CAUTION: LEFT AND RIGHT HAND S-CAMSHAFTS ARE NOT INTERCHANGEABLE.**

3. Push the air chamber mounting bracket onto the S-camshaft. Then align the bracket on the steering arm or upper kingpin cap. Insert the two 7/8" bolts and torque to **250 lb.-ft.**
4. Fit the air chamber mounting studs through their holes in the bracket and secure with the two 5/8" locknuts and washers. Torque to **150 lb.-ft.** See **Figure 26.**

**Figure 26**



5. Install the inner washer and slack adjuster over the S-camshaft with the 7/16" adjusting screw pointing toward the front of the axle. Begin by placing two .060" and two .030" spacers over the end of the S-camshaft. Install the snap ring. See **Figure 27.**

**Figure 27**



6. Tap on the cam end of the shaft with a soft mallet to move the shaft inboard. Attempt to insert a .030" spacer between the existing spacers and the snap ring. If the spacer slides easily between the two, remove the snap ring and install the spacer. Reinstall the snap ring and repeat this step until a .030" spacer can no longer be inserted.
7. Thread the air chamber push rod into the clevis until it bottoms out. Then back off two turns and torque locknut to **75 lb.-ft.**
8. Hook the two lower retaining springs into each brake shoe. By grasping the shoes at the top and spreading them apart, the circular recess in the bottom of each shoe can be fit over the anchoring pin on the spindle yoke. Install the large upper brake release spring. Then using a bar, pry the shoes away from the S-cam and insert the cam shaft rollers. See **Figure 28.**

**CAUTION: DO NOT ALLOW YOUR FINGERS TO COME BETWEEN THE SHOE AND THE S-CAM!**

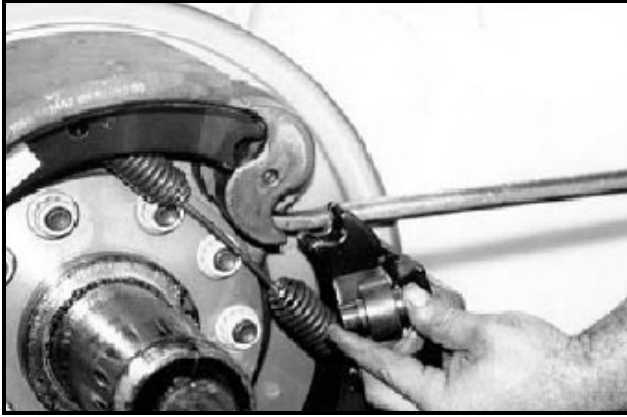
**Figure 28**

3. Install drive flange over the drive studs. Install the drive flange locknuts and torque to **175 lb-ft.** using a uniformed torque sequence.
4. Mount the brake drum over the wheel studs.
5. Grease all lubrication points before returning the vehicle to service.

9. Refer to Section 3.8 for brake adjustment.

#### 6.4 WHEEL BEARINGS, HUBS, AND BRAKE DRUM

1. Press both wheel bearing cups into the hub. Thoroughly pack both bearing cones with grease, and coat the inside surfaces of the hub and bearing cups. Install the inner wheel bearing cone and the hub seal in the hub. See **Figure 29**. Lightly coat the outer surface of the spindle with grease to reduce the chance of the inner wheel bearing cocking upon installation of the hub.

**Figure 29**

2. Grasping the outer circumference of the hub at the 12 and 6 o'clock positions, push the hub straight on to the spindle. If difficulty is encountered, try rocking the hub slightly to free the inner bearing. Once the hub is in position, the outer bearing and adjusting nut can be installed. Refer to Section 3.2 for wheel bearing adjustment.

#### NOTES:



## **7.0 ADDITIONAL SERVICE PROCEDURES**

### **7.1 STEERABLE DRIVE END REMOVAL**

This procedure is useful in cases where it is necessary to gain access to the inner axle seal or to remove the differential, yet complete tear down of the steerable end is not desirable. Removal of the steerable end will be greatly facilitated if acquisition or fabrication of the special mounting tool is possible. The steerable end removal tool is available from Fabco, or it can be fabricated from the drawings in Section 9.13 Special Tools.

1. Remove the cotter pins from both tie rod ends. Unscrew both castle nuts so that only a few threads remain in engagement. Use a suitable puller to extract the tie rod end from the suspension yoke. Do not strike the tie rod end ball stud. Completely remove the nuts and tie rod.
2. Remove all eight 12-point cap screws which secure the universal joint to the axle shaft and yoke shaft. Pry the joint away from the shafts and remove. See **Figure 30**.

**Figure 30**



3. Loosen the upper kingpin adjusting screw jam nut and back out the adjusting screw until the spindle yoke stops moving downward and is resting on the suspension yoke.
4. Remove the steering arm or upper kingpin cap nuts along with the brake bracket bolts. Using a 7/16" socket, rotate the hex extension on the front of the slack adjuster counter-clockwise. At

the same time the brake bracket will be lifted back off the steering arm or upper kingpin cap.

5. Remove the steering arm or upper kingpin cap. If difficulty is encountered, turn the adjusting screw back in to force the arm or cap off the studs.
6. Attach the steerable end removal tool to a transmission jack and mount it to the steerable end by means of the lowest three wheel studs and nuts. Thread the 3/4"-16 x 5" bolt up through the bottom of the base plate and into the nut furthest from the vertical plate. Adjust the bolt to contact and support the brake drum.

**CAUTION: IF THE TOOLS IS NOT AVAILABLE, ALTERNATE MEANS TO SUPPORT THE STEERABLE END MUST BE FOUND BEFORE CONTINUING THIS PROCEDURE.**

7. Loosen the lower kingpin locknut (see Section 9.14 Special Tools) and completely remove the locknut, lock washer and lower kingpin ball stud (see Section 9.15 Special Tools) from the spindle yoke.
8. Remove the 1"-14 upper king pin bolt. Special tool number 866-0744 (see Section 9.8) should now be used to pull the upper kingpin ball stud from the suspension yoke. Using the upper kingpin ball stud puller, fit one tube over the locating dowel and the other is allowed to float freely. Insert the 1 1/8"-12 x 3 1/2" UNF bolt through the spacer and the tool's central hole. The bolt should then be threaded into the top of the upper kingpin ball stud. Tighten the bolt until the ball stud is pulled free from the suspension yoke.
9. Roll the jack backward to disengage the steerable end from the axle. See **Figure 31 & 32**.

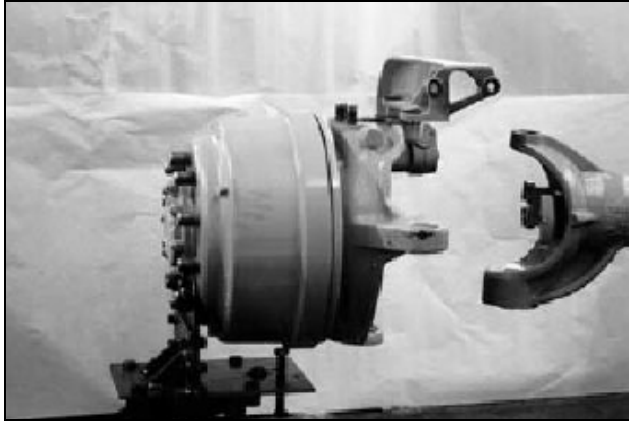
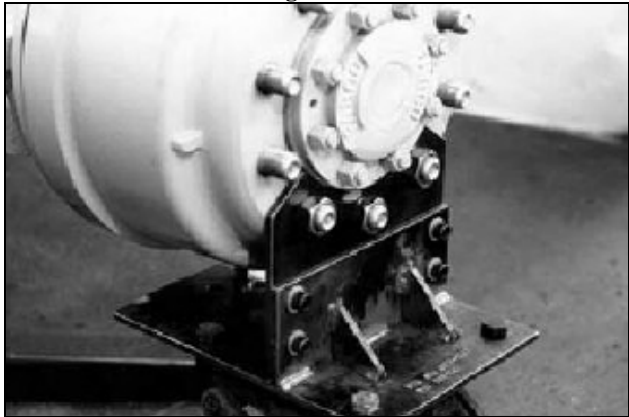
**Figure 31****Figure 32**

10. Installation is the reverse of removal. See Section 8.0 for correct torque specifications. After assembly, complete the kingpin adjustment procedure (Section 3.3), and grease upper and lower kingpins.

## 7.2 DIFFERENTIAL CARRIER REMOVAL

1. Remove the oil drain and fill plugs from the differential housing to drain lubricant.
2. Remove the tie rod and both steerable ends as described in Section 7.1. With draw both axle shafts from the axle.

**CAUTION:** A MEANS TO SUPPORT THE DIFFERENTIAL CARRIER MUST BE FOUND BEFORE CONTINUING THIS PROCEDURE.

3. Remove all differential mounting bolts, washers and nuts. Roll the differential carrier away from the axle.

**NOTE:** REFER TO THE APPROPRIATE AAM AXLE SERVICE MANUAL FOR INFORMATION REGARDING DIFFERENTIAL SERVICING.

4. Installation is the reverse of removal. Apply a bead of Loctite gasket eliminator (flange sealant #515 or equivalent) around the differential carrier mounting face on the axle housing. See Section 8.0 for correct torque values.
5. Clean the magnetic drain plug, and fill the axle to the bottom edge of the level hole with the appropriate lubricant.

## NOTES:



**8.0 TORQUE SPECIFICATIONS**

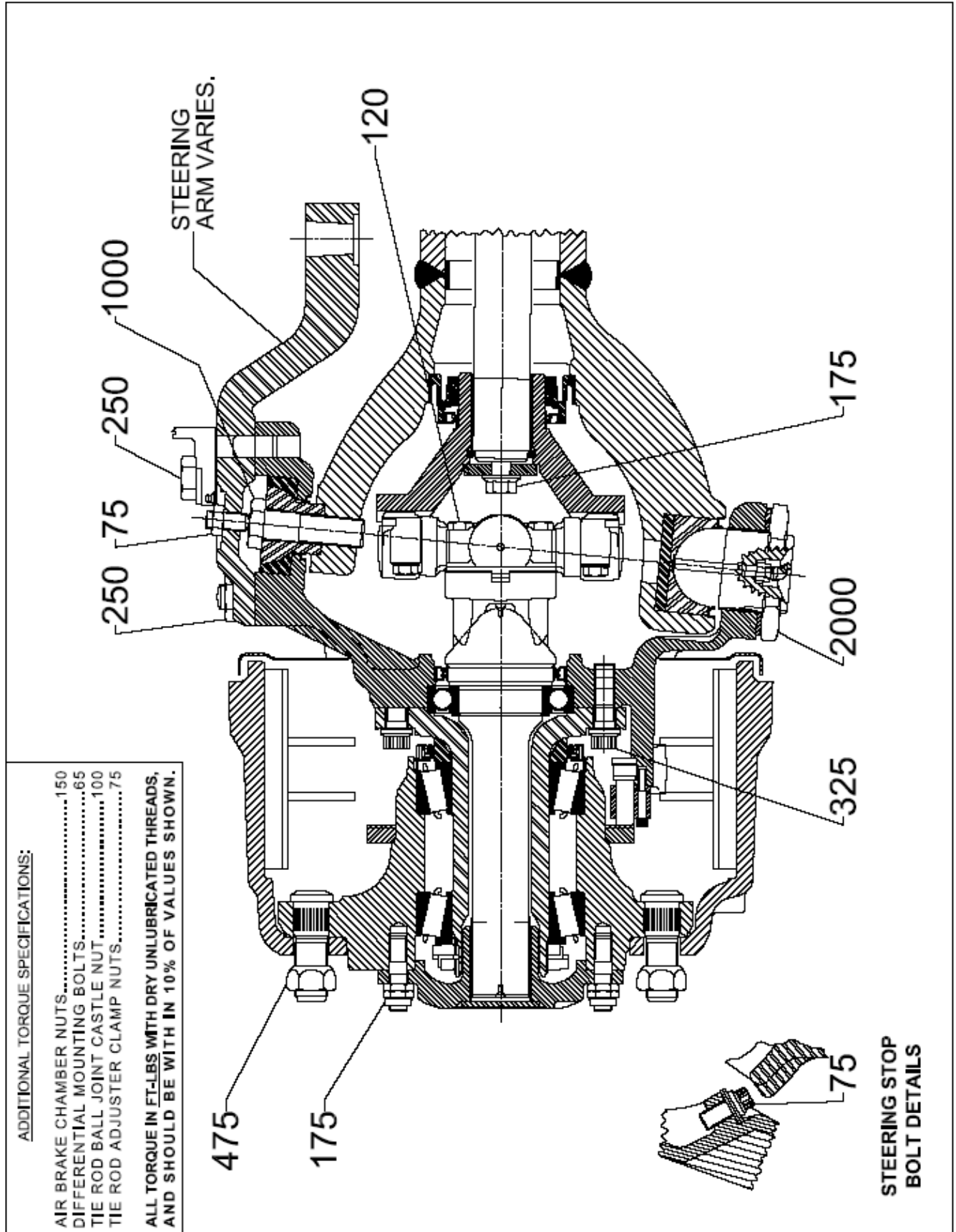

## **9.0 SPECIAL TOOLS**

### **9.1 GENERAL**

Service tools may be manufactured to these drawings or Fabco Automotive may be contacted for pricing and availability.

The manufacture of these tools should be carried out by professional machinists and certified welders, following typical and good workmanship procedures and safe practices.

### 9.1 WHEEL END INNER SEAL DRIVER

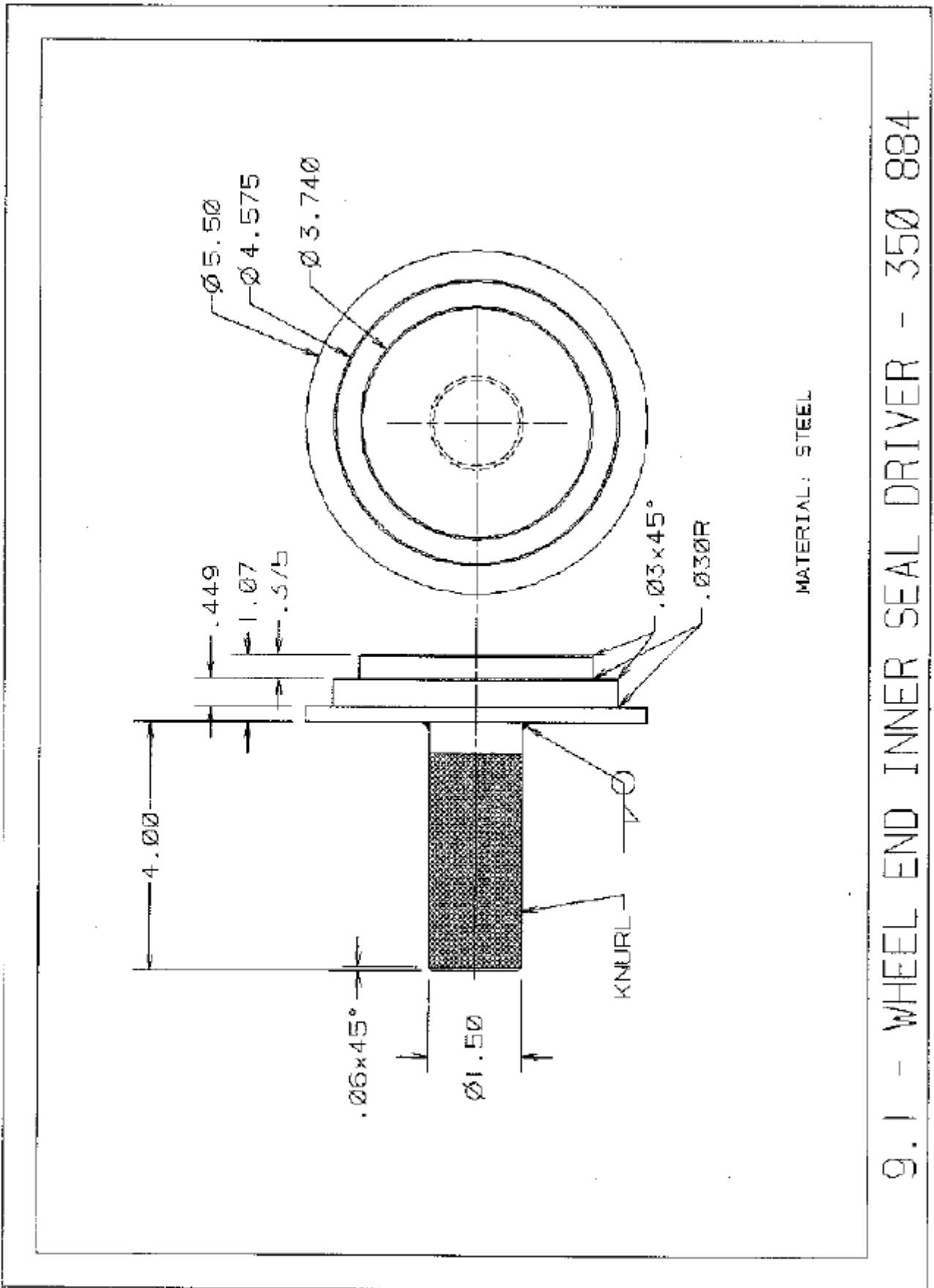

### 9.2 WHEEL HUB SEAL DRIVER

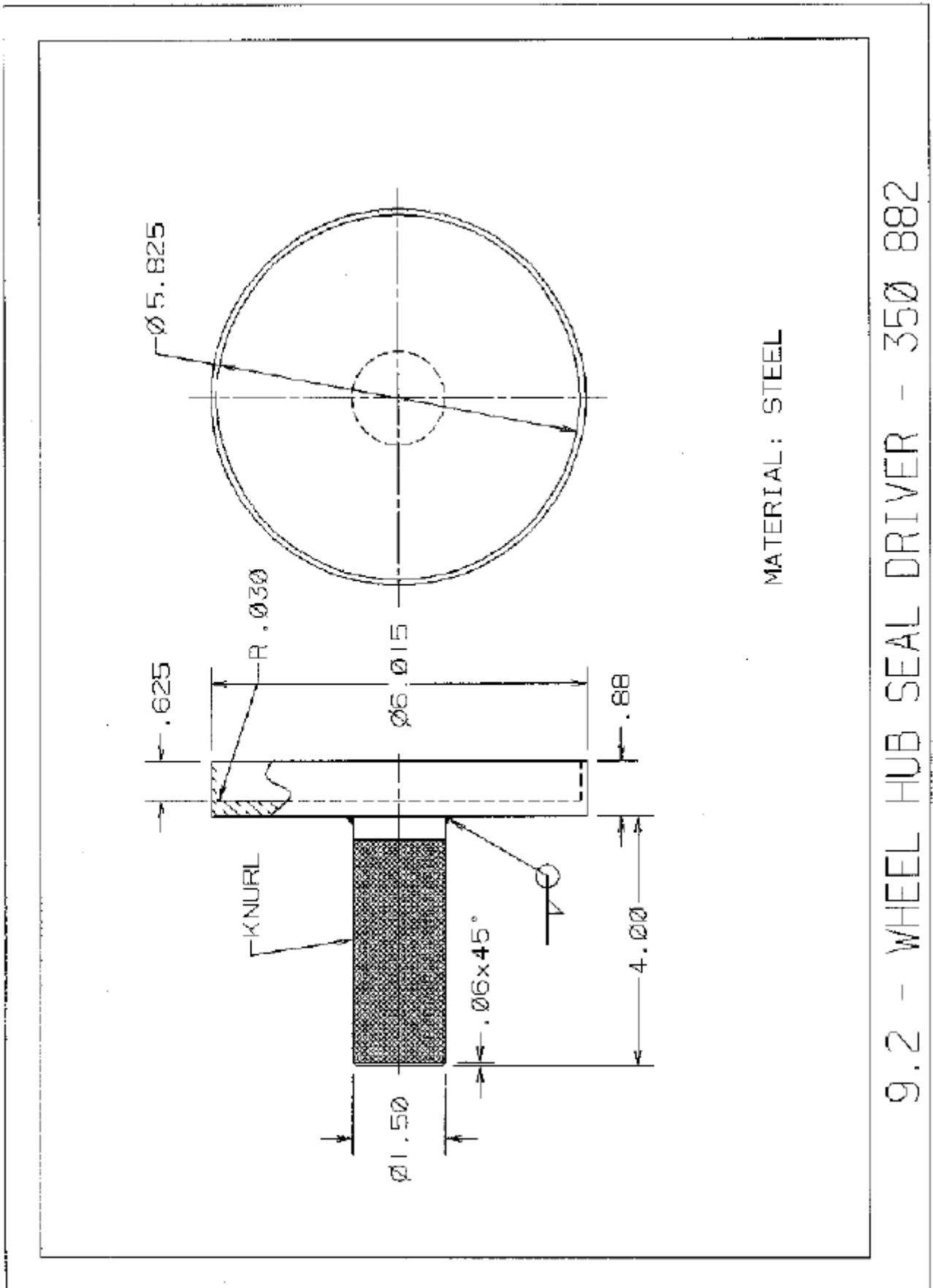

9.2 - WHEEL HUB SEAL DRIVER - 350 882

### 9.3 LOWER KINGPIN SEAL DRIVER

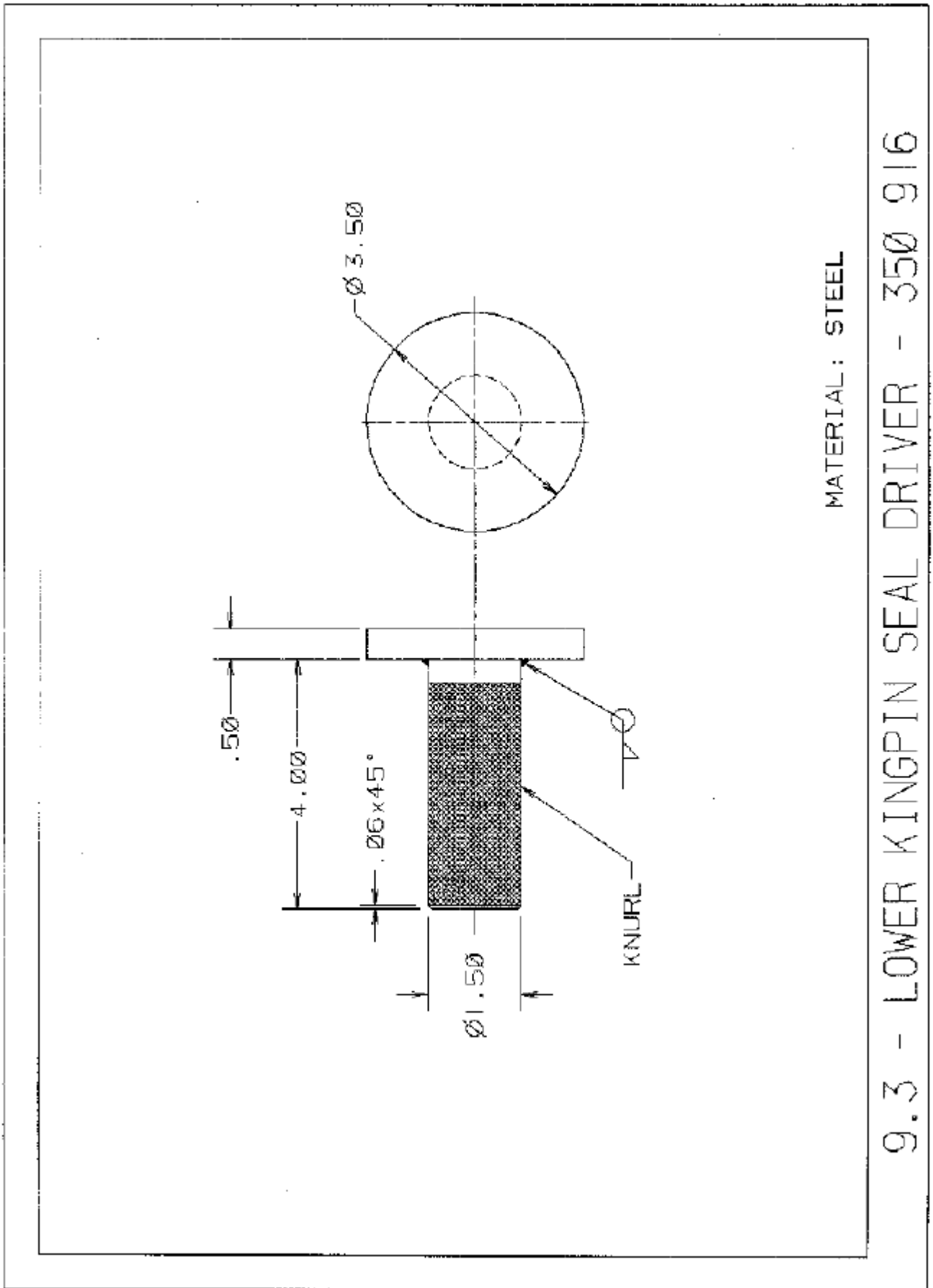

MATERIAL: STEEL

9.3 - LOWER KINGPIN SEAL DRIVER - 350 916

### 9.4 LOWER KINGPIN BEARING DRIVER

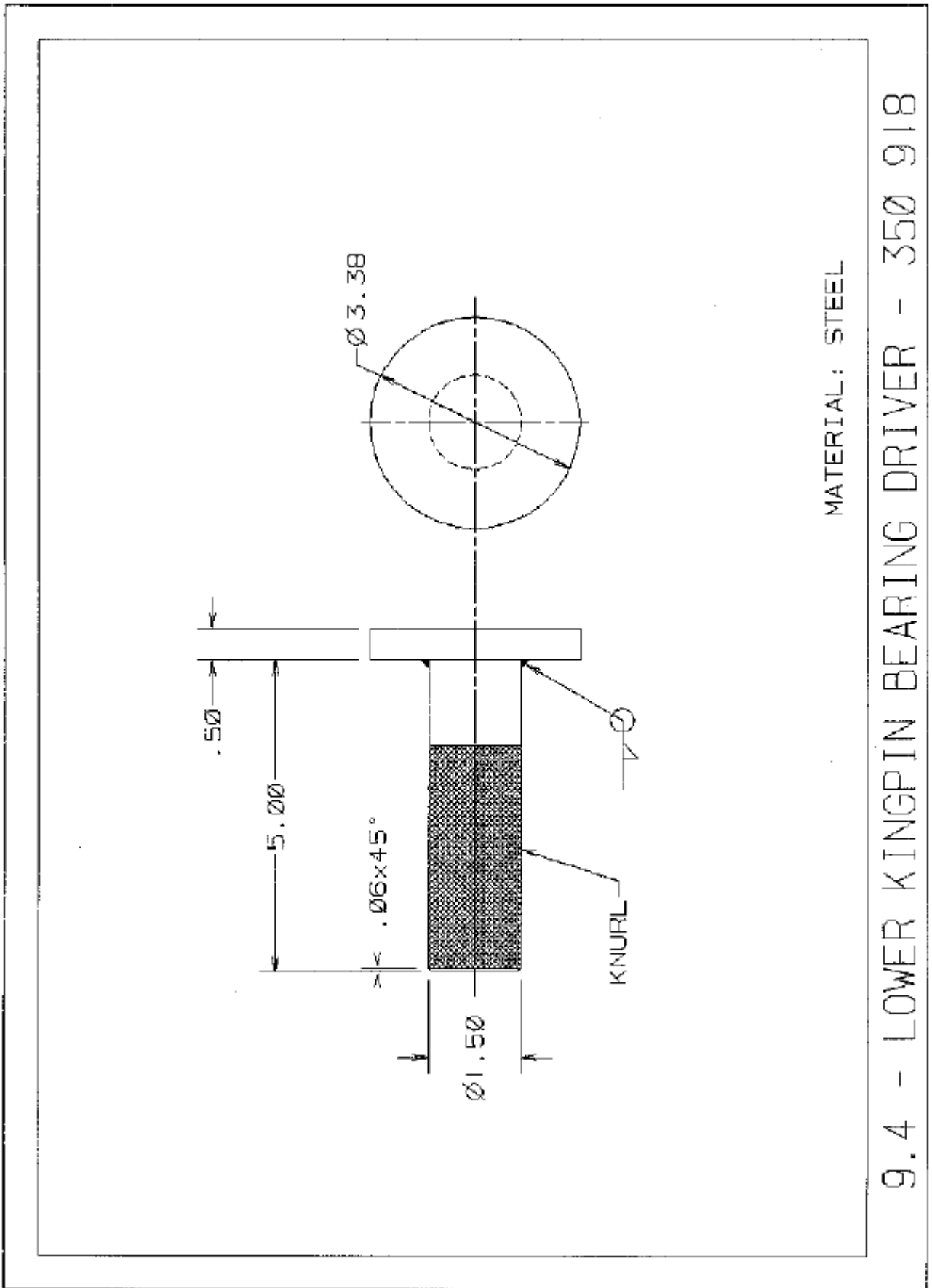

### 9.5 UPPER KINGPIN SEAL DRIVER

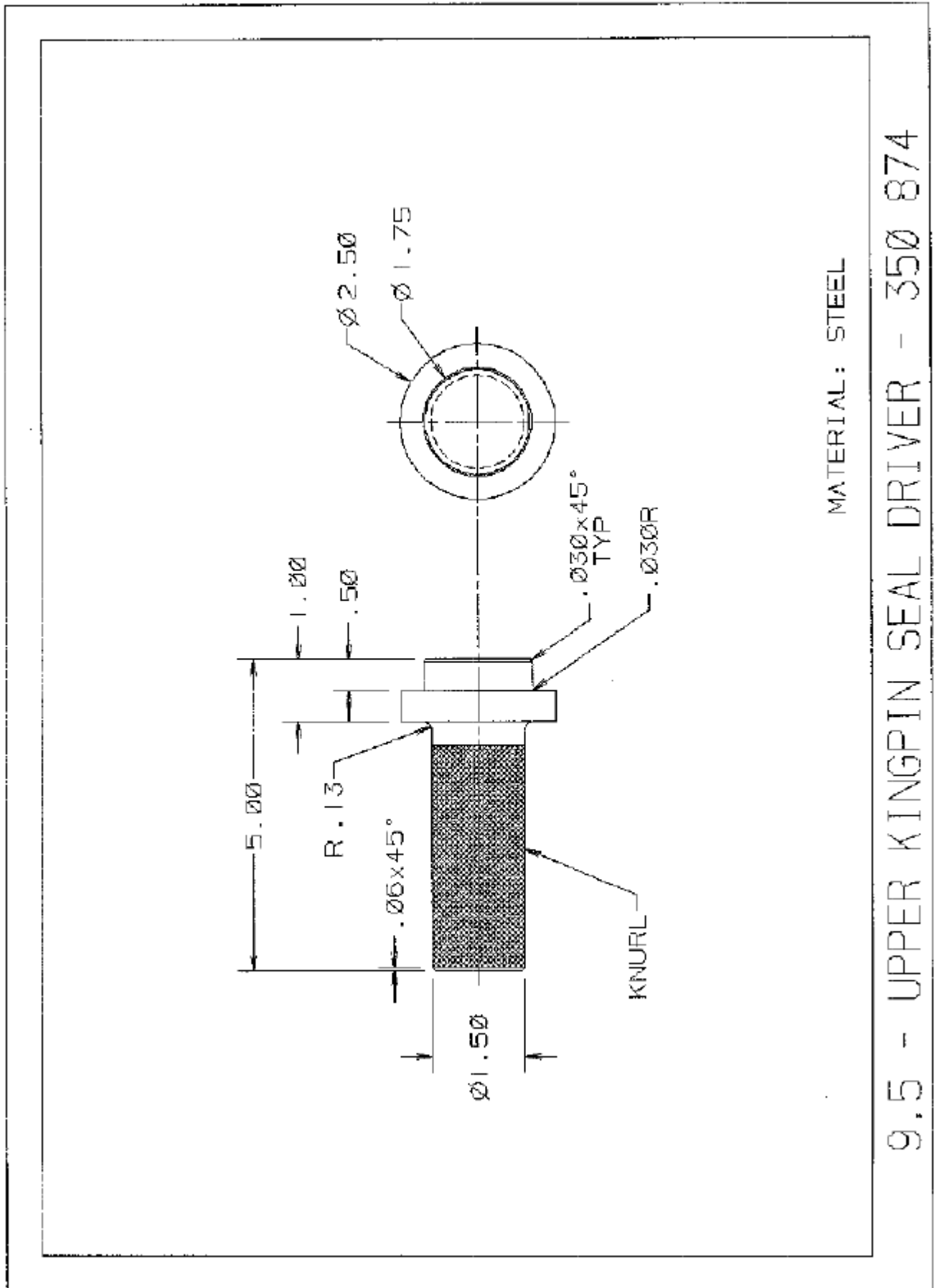



### 9.6 UPPER KINGPIN BEARING DRIVER

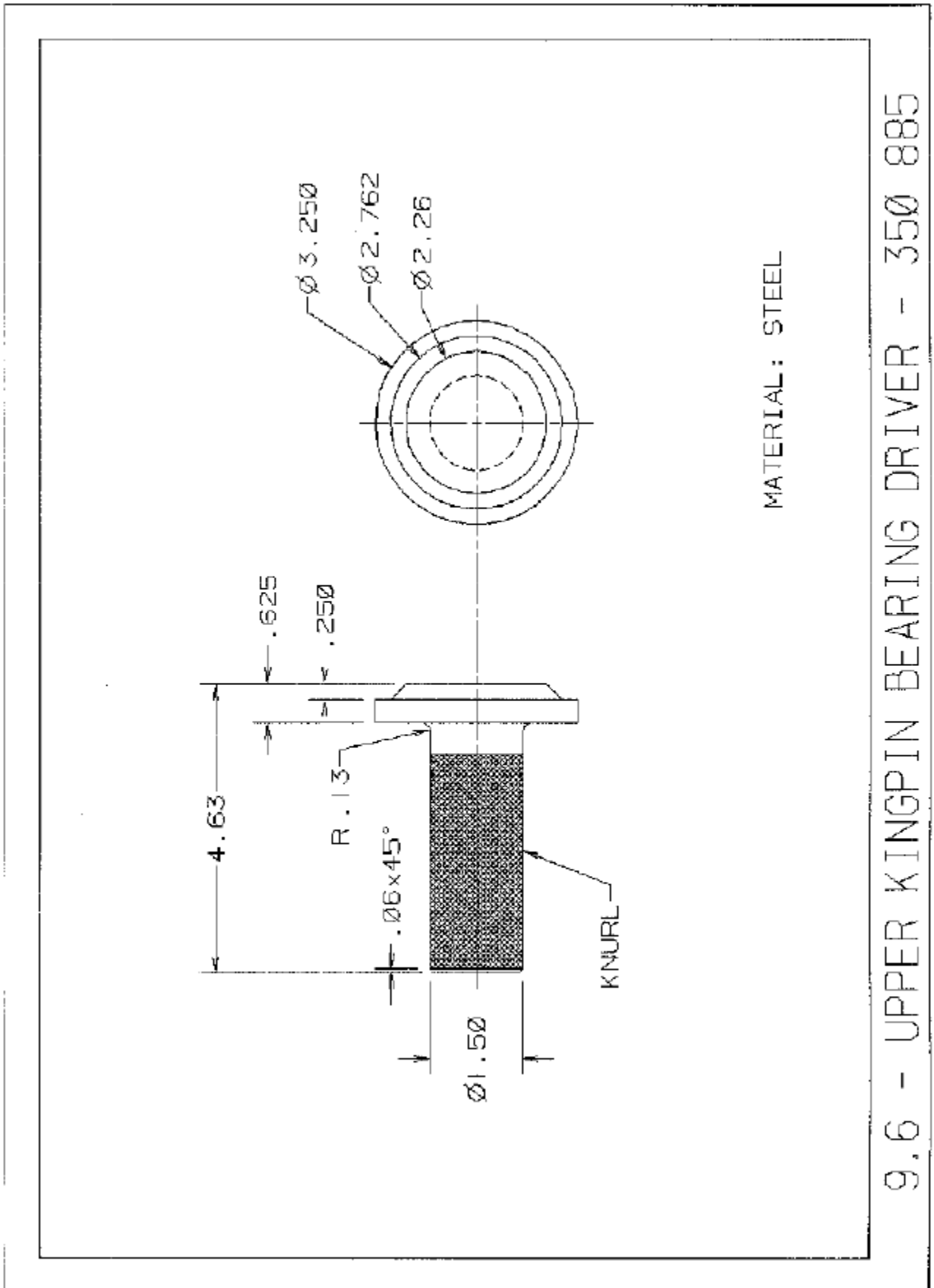

### 9.7 INNER AXLE SEAL DRIVER

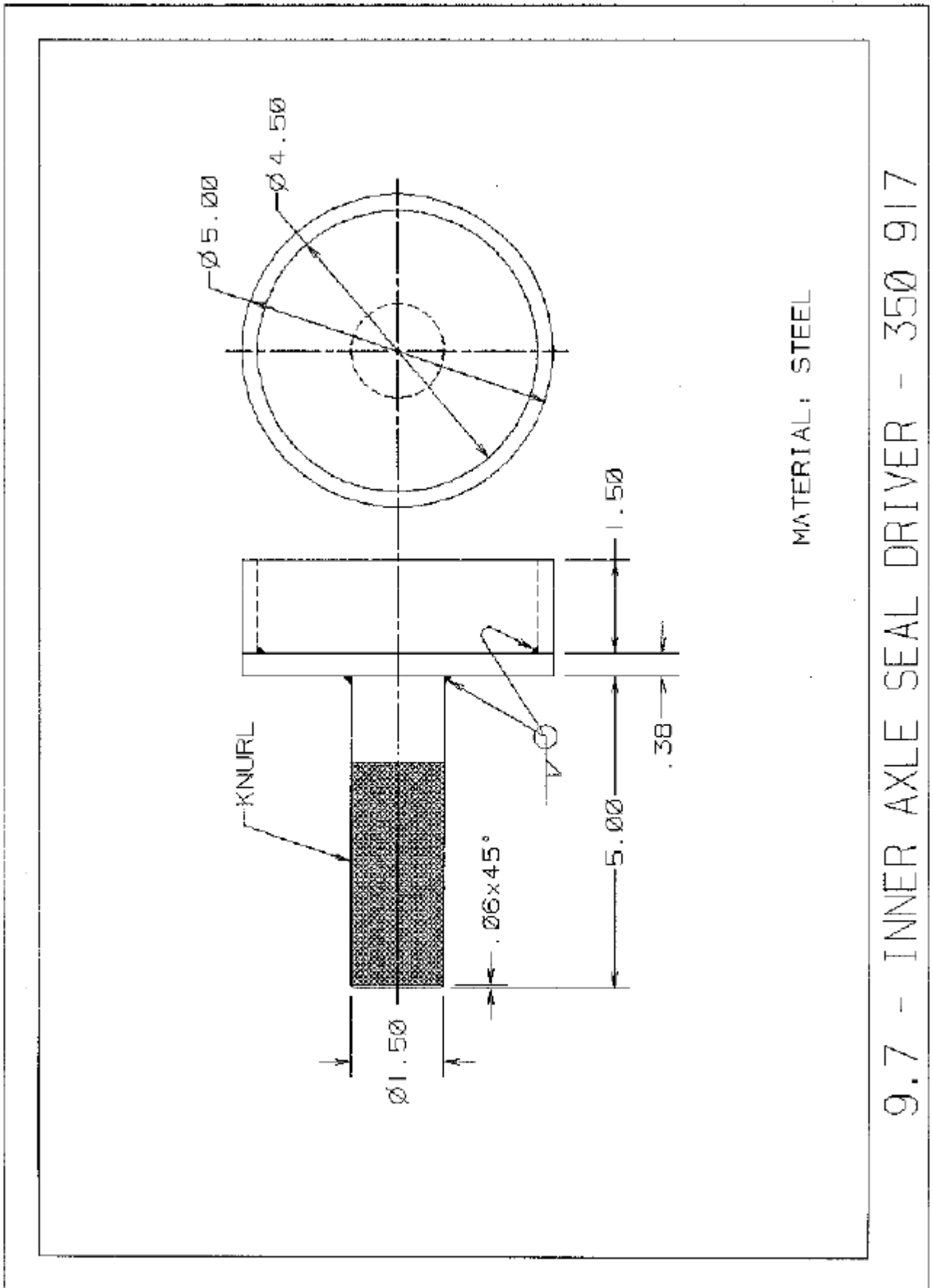

9.8 UPPER KINGPIN BALL STUD PULLER

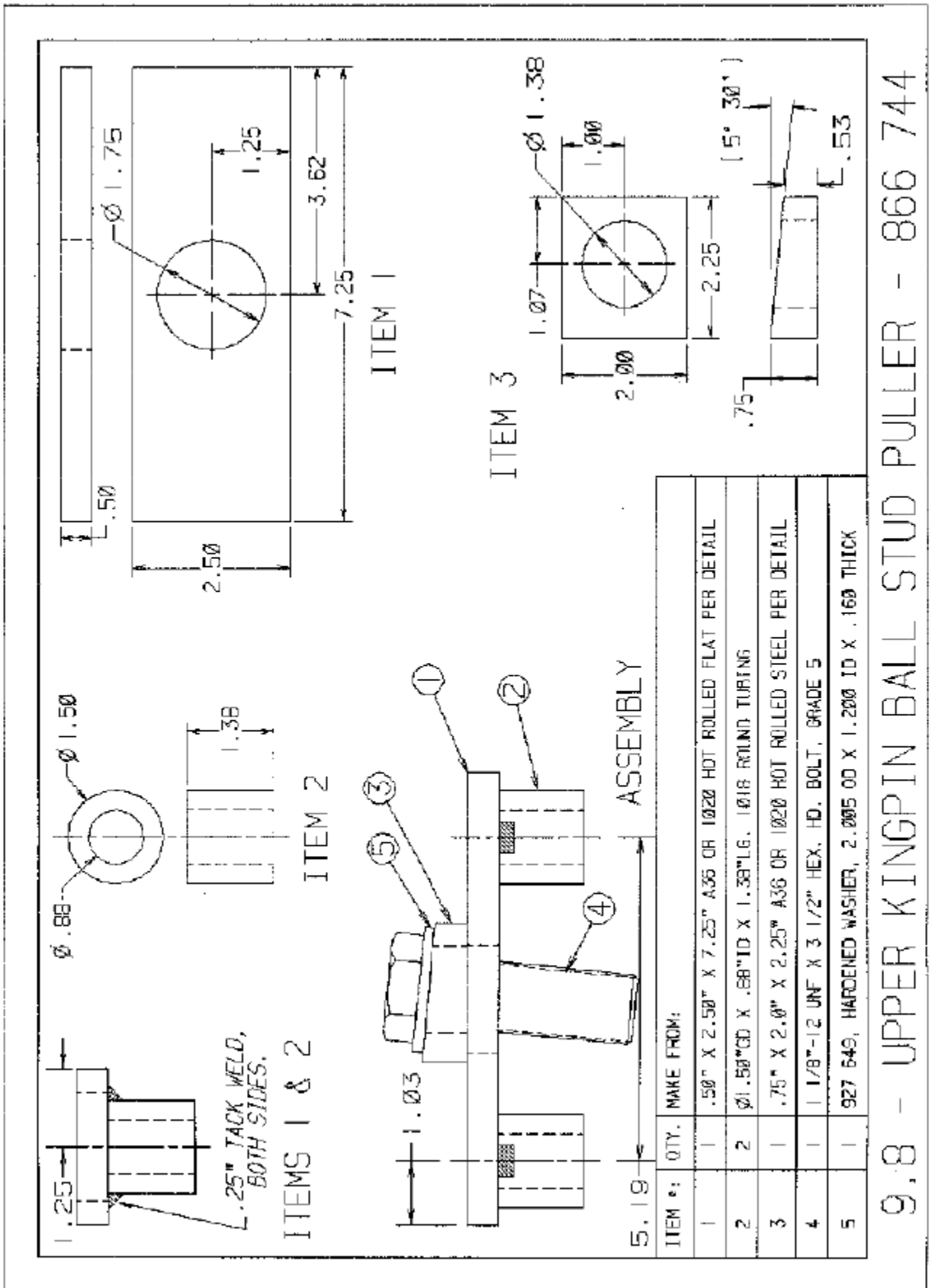

9.8 - UPPER KINGPIN BALL STUD PULLER - 866 744

### 9.9 CAMSHAFT SEAL DRIVER (BRAKE BRACKET)

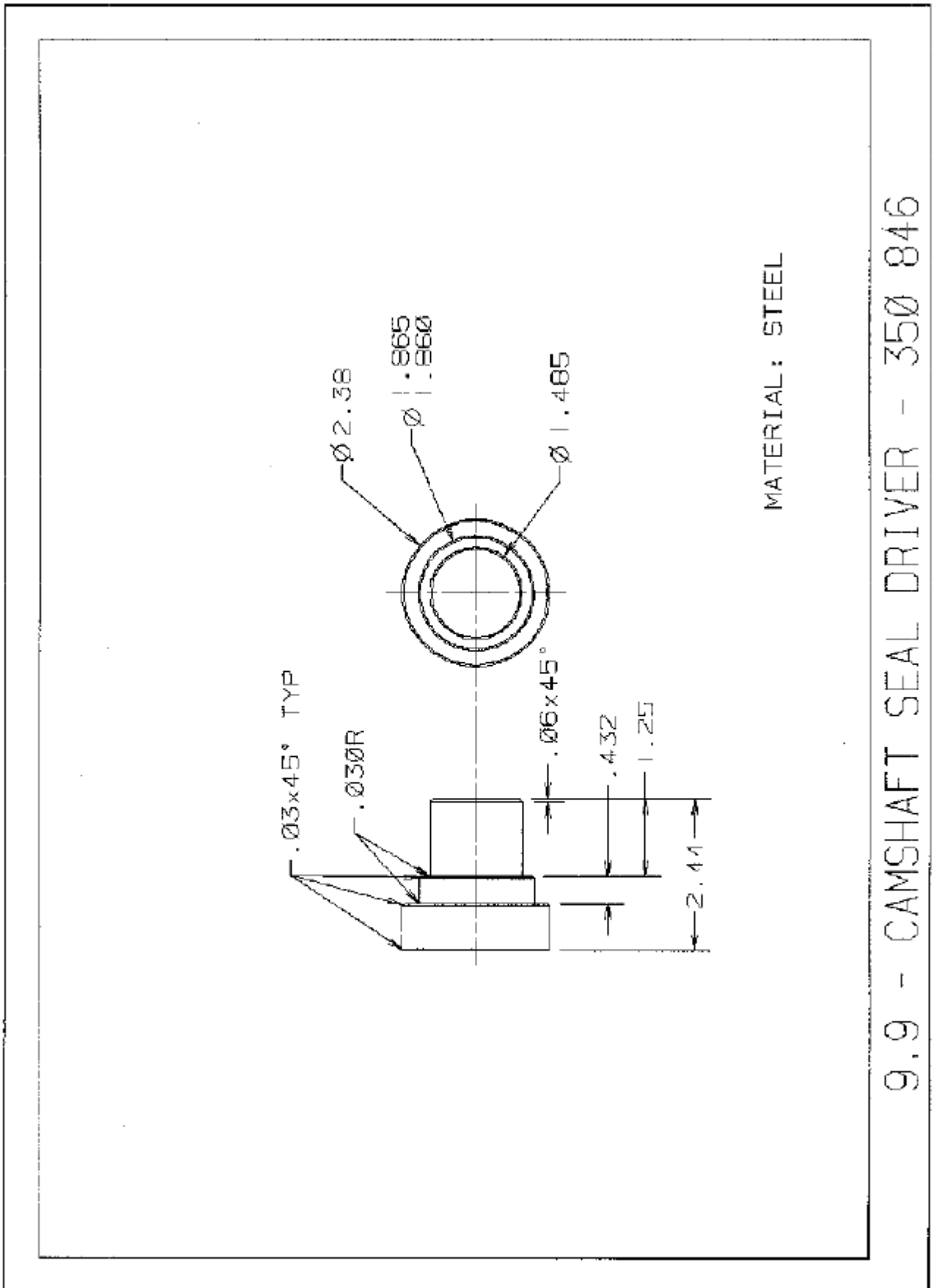

MATERIAL: STEEL

9.9 - CAMSHAFT SEAL DRIVER - 350 846

### 9.10 CAMSHAFT BUSHING DRIVER (BRAKE BRACKET)

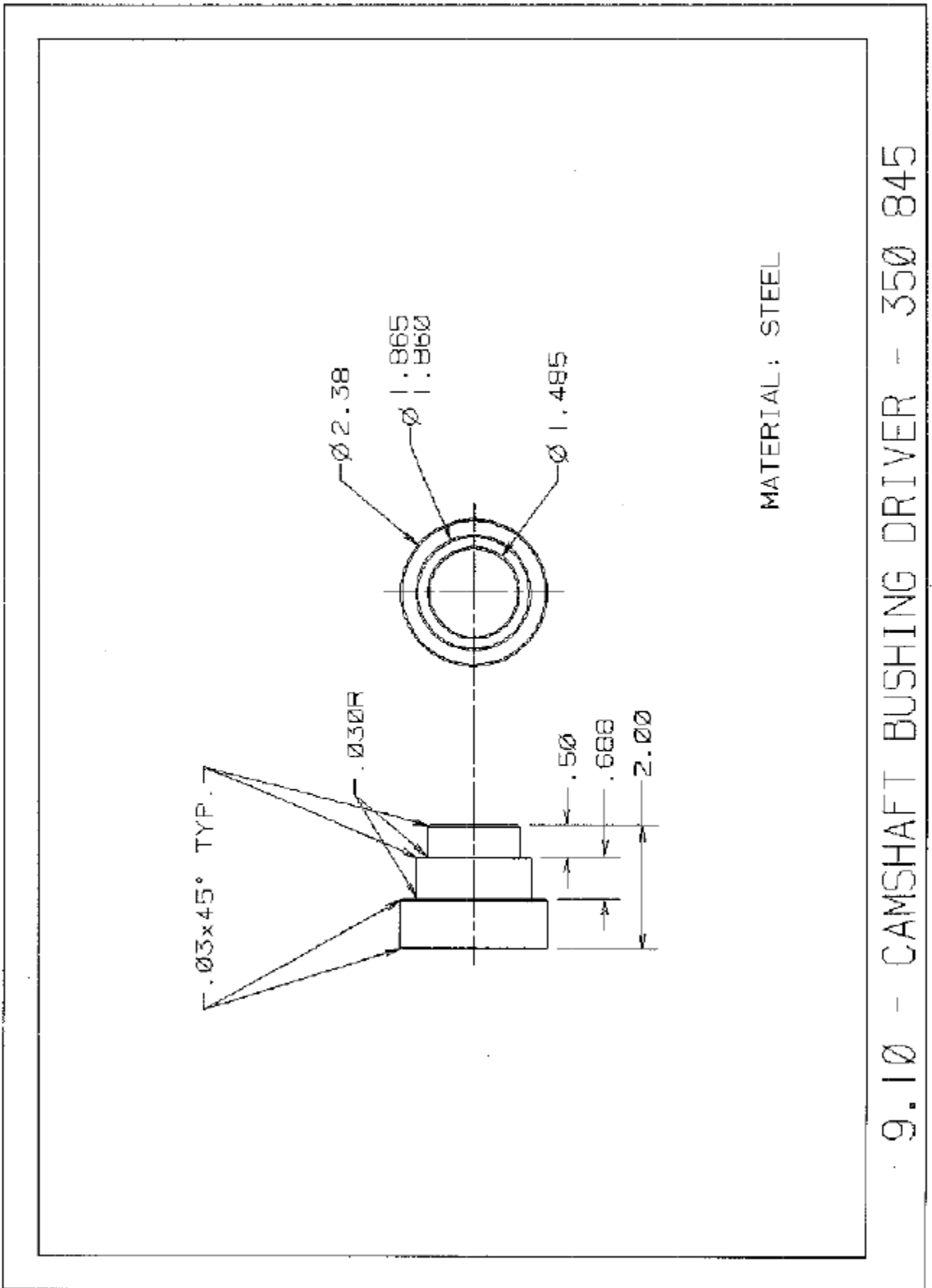

9.10 - CAMSHAFT BUSHING DRIVER - 350 845

9.11 CAMSHAFT SEAL DRIVER (SPINDLE YOKE)

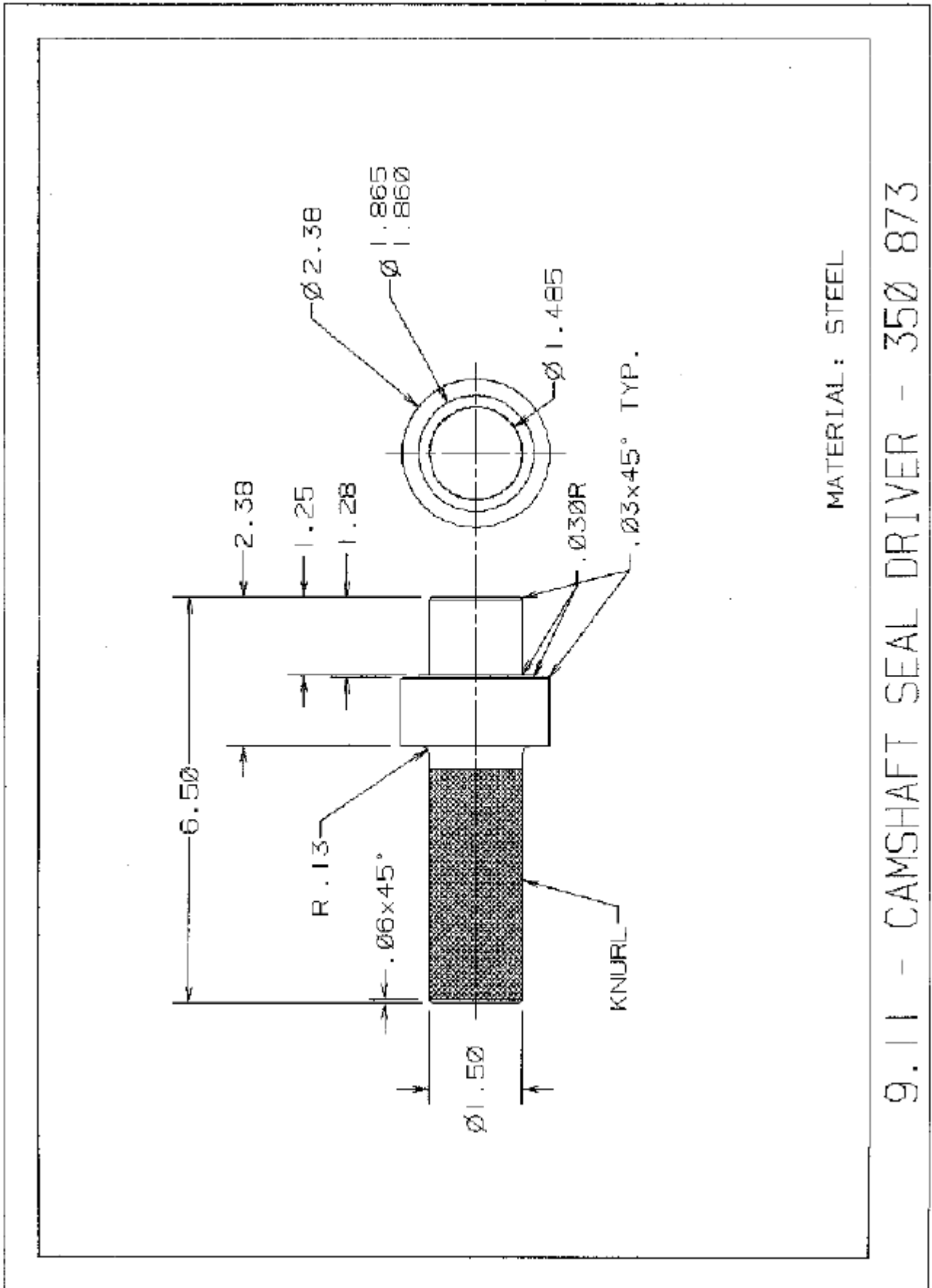





### 9.13 STEERABLE END REMOVAL TOOL

ITEM	PART NO.	DESCRIPTION	QTY.
1	866 734	FIXTURE	1
3	866 736	1 1/25 END ADAPTER	A/R
5	283 258	3/4-16 UNF x 5 HH BOLT	1
6	265 266	1/2-20 UNF x 1.5 HH BOLT	4
7	806 268	1/2 20 UNF NUT	4

  

STEERABLE END REMOVAL TOOL ASSEMBLY - 866 741

9.13



9.13 STEERABLE END REMOVAL TOOL

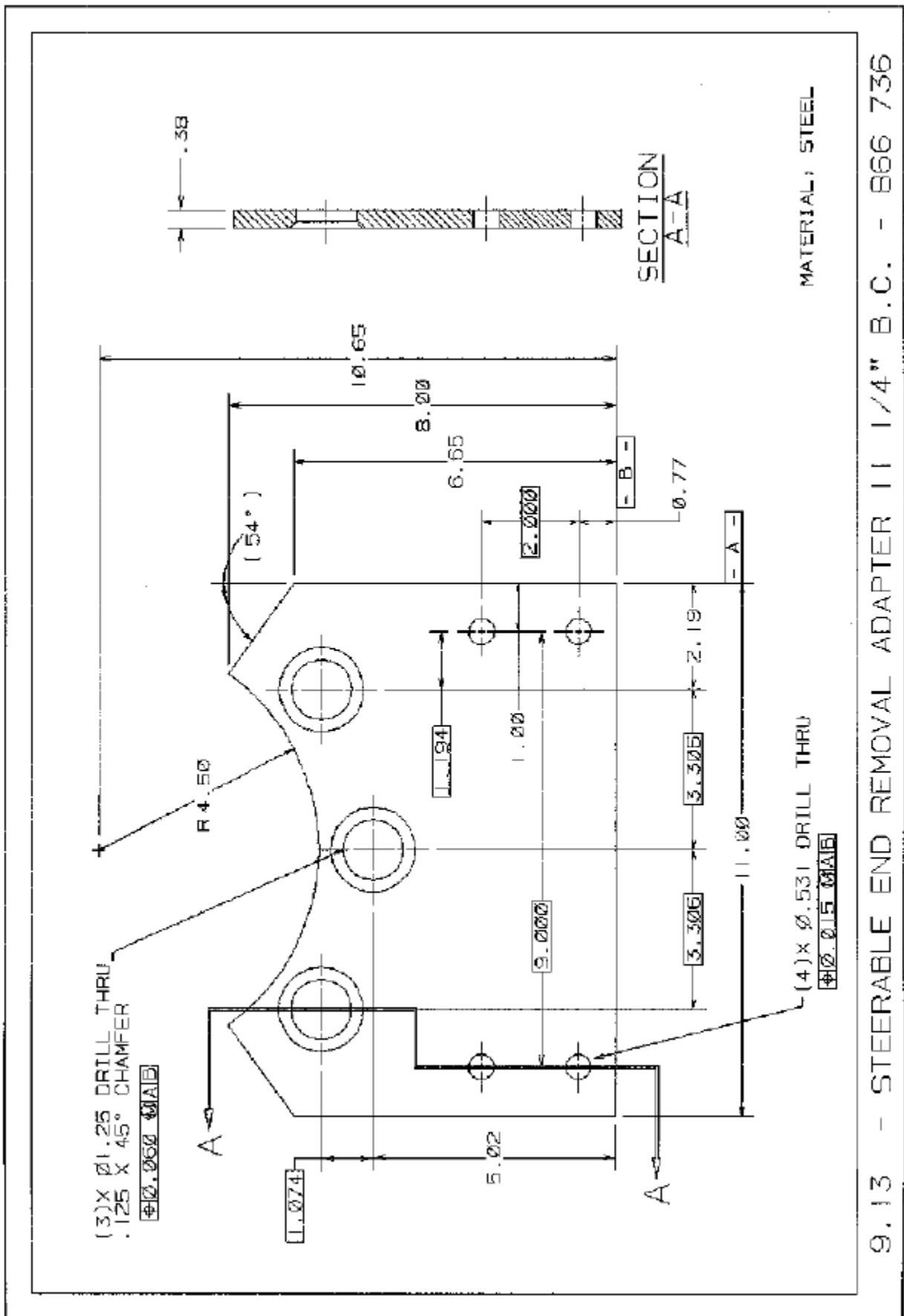

9.13 - STEERABLE END REMOVAL ADAPTER 11 1/4" B.C. - 866 736

### 9.14 LOWER KINGPIN LOCKNUT TOOL

USE URREA #10066 1.0 INCH DRIVE 6 POINT  
4.125 INCH IMPACT SOCKET OR EQUAL.

9.14 – LOWER KINGPIN LOCKNUT TOOL

### 9.15 LOWER KINGPIN BALL STUD REMOVAL TOOL

13/16" HEXAGON STOCK  
1.5" LONG

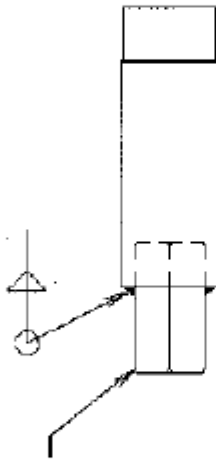

USE A SNAP ON: TW 261 STANDARD SOCKET  
TS 261 DEEP SOCKET



ALTERNATIVE TOOL: 9/16" - 12 UNC x 2" HH CAP SCREW OR  
9/16" - 18 UNF x 2" HH CAP SCREW WITH  
TWO JAM NUTS.

9.15 - LOWER KINGPIN BALL STUD REMOVAL TOOL

## 9.16 HUB BEARING LOCKNUT TOOL

USE EITHER OF THE FOLLOWING 6-POINT SOCKETS

OTC 1915 4 1/8"  
SNAP-ON ANS 1915A 4 1/8"

9.16 – HUB BEARING LOCKNUT TOOL

**NOTES:**

A large, empty rectangular box with a thin black border, intended for handwritten notes.