

Isringhausen

Seat Model 6800/338 Bus
Seat Model 6800/338 Premium LX

Service Manual



Read and understand this manual before servicing this seat.



INTRODUCTION

**MODEL 6800/338 BUS
MODEL 6800/338 PREMIUM LX**

SERVICE AND REPAIR

Proper service and repair are important to the safe, reliable operation of this seat. Service and repair should be preformed only by responsible persons who have been properly instructed and authorized to do so. The procedures recommend in this manual are safe effective methods for performing service and repair operations.

We could not possibly know, evaluate, and advise the service trade of all conceivable ways in which service can be done or of the possible hazardous consequences of each way. If you use a service procedure which is not recommended, be sure that personal safety and equipment safety will not be jeopardized.

It is the responsibility of the mechanic performing the service and repair to:

- inspect for abnormal wear and damage
- choose a repair procedure that will ensure your safety, the safety of others, and the safe operation of the equipment
- fully inspect and test the equipment to ensure that the repair or service has been properly performed and the equipment will function properly.

This manual describes the correct service procedures for Model 6800/348 Premium seats. The information in this manual was current at the time of printing and is subject to change without notice or liability.

READ AND UNDERSTAND THIS MANUAL AND THE OPERATOR'S MANUAL

Learn how to service Model 6800/348 Premium seats. Failure to do so could result in personal injury or equipment damage. Consult your dealer if you do not understand the instructions in this manual and/or need additional information.

KEEP THIS MANUAL

This manual should be considered a permanent part of the seat and be available for reference when servicing the seat.

WARRANTY

Warranty is provided as part of Isringhausen's support program for customers who operate and maintain their seat as shown in this manual. See the warranty for details.

**MODEL 6800/338 BUS
MODEL 6800/338 PREMIUM LX**

TABLE of CONTENTS

subject	page	subject	page
INTRODUCTION	ii	HEIGHTADJUSTMENT HANDLE	11
GENERAL SAFETY	2	HEIGHTADJUSTMENT CYLINDER AND CAM	11
TROUBLESHOOTING	3	HORIZONTALADJUSTMENT SLIDE SET	12
INSPECTION	4	QUICK AIR RELEASE VALVE AND HANDLE	12
REMOVALAND INSTALLATION		QUICK AIR RELEASE VALVE - SUSPENSION	13
ARMREST	6	RISER AND SUSPENSION	13
BACKREST	6	SEAT FRAME	14
BACKRESTASSEMBLY	7	SEAT FRAME TOOTH PLATE	14
LUMBAR/BOLSTER AIR BAGS	7	BACKRESTADJUSTMENT HANDLE	15
LUMBAR/BOLSTER VALVE	8	TILT ADJUSTMENT HANDLE	15
COVER FRONT, LH AND RH	8	AIR SPRING	16
SEAT PAN ASSEMBLY	9	BOOT, BOOTADAPTER PLATE, BOOT BAR, AND TETHERS	16
GLIDE - SEAT PAN	9	ADJUSTABLE SHOCK ABSORBER CABLE	17
SEAT PAN ASSEMBLY LEVER AND HANDLE	10	ADJUSTABLE SHOCK ABSORBER	17
HEIGHTADJUSTMENT VALVE - SUSPENSION	10	DISTRIBUTION VALVE	18
		HEADREST	18
		PARTS	19

REMOVAL AND INSTALLATION PAGE NUMBERS

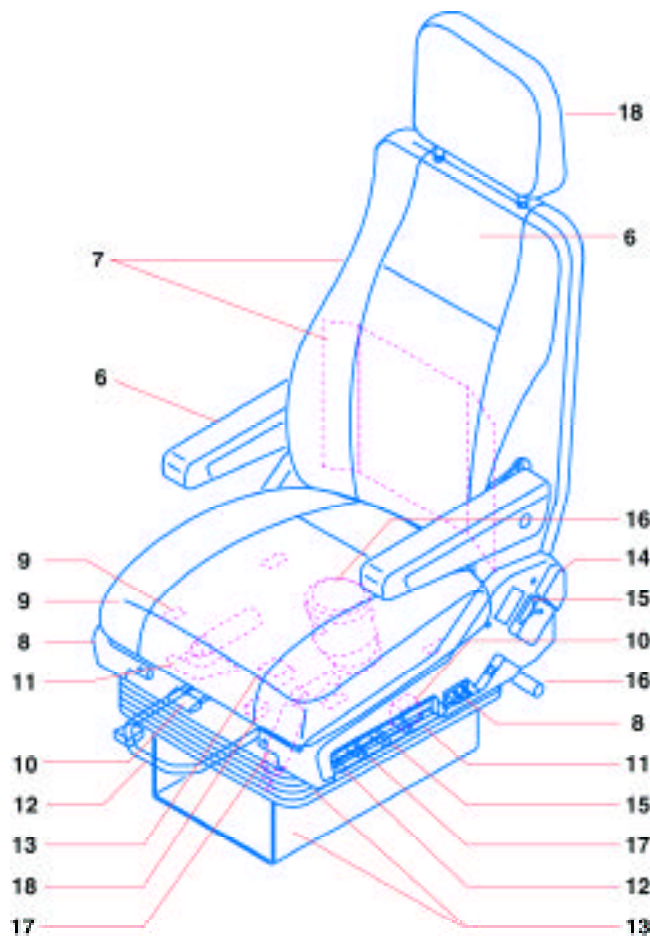

GENERAL SAFETY

MODEL 6800/338 BUS
MODEL 6800/338 PREMIUM LX

In this manual safety messages will alert persons to a specific hazard, the degree or level of hazard seriousness, the probable consequences of involvement with the hazard, and how the hazard can be avoided. Safety messages will include the safety alert symbol, a signal word, and a word message.

SAFETY ALERT SYMBOL



Indicates a potential personal safety hazard.

SIGNAL WORDS

DANGER: Indicates an imminently hazardous situation which, if not avoided, will result in death or serious injury.

WARNING: Indicates a potentially hazardous situation which, if not avoided, could result in death or serious injury.

CAUTION: Indicates a potentially hazardous situation which, if not avoided, may result in minor or serious injury.

WORD MESSAGE

The word message will identify the hazard, indicate how to avoid the hazard, and advise of probable consequence of not avoiding the hazard.

Problem	Cause	Solution	Page
Armrest will not stay in position.	Armrest control is defective.	Replace armrest.	6
Backrest will not adjust and/or stay adjusted.	Teeth on backrest are defective.	Replace backrest.	6
	Backrest seat latch is defective.	Replace backrest seat latch.	14
Lumbar/Bolster will not inflate.	No air supply to seat.	90 to 145 psi req'd.	5
	Air lines leak.	Replace air lines.	7
	Valve is defective.	Replace valve.	8
	Air bags leak.	Replace air bags.	7
Height will not adjust and/or stay adjusted.	Height adj. cam is defective.	Replace height adj. cam.	11
	Height adj. cylinder is defective.	Replace height adj. cylinder.	11
	Height adj. valve is defective.	Replace height adj. valve.	10
Horizontal slide will not adjust and/or stay adjusted.	Horizontal slide is defective.	Replace horizontal slide.	12
Seat pan assem. will not adjust and/or stay adjusted.	Seat pan lever is defective.	Replace seat pan lever.	10
	Seat pan glides are defective.	Replace seat pan glides.	9
Quick air release will not function.	No air supply to seat.	90 to 145 psi req'd.	5
	Valve is defective.	Replace valve.	12
Adjustable shock absorber will not adjust.	Shock absorber is defective.	Replace shock absorber.	17
	Shock absorber cable is defective.	Replace shock absorber cable.	17
Suspension will not function properly.	Suspension is defective.	Replace suspension.	13

INSPECTION

MODEL 6800/338 BUS
MODEL 6800/338 PREMIUM LX



CAUTION

Avoid the risk of injury.
Vehicle must be in a safe parked position before inspecting seat.

Visually inspect the seat. Look for damaged or worn upholstery and parts. The seat should be clean and free of dirt and debris. Check all the seat functions they should work properly and be in good condition.

1. Adjustable armrest

Should move up freely, the adjustment knob should be easy to use, the armrest must stay in the adjusted position.

2. Backrest adjustment

The control should be easy to release then the backrest should move freely. The backrest must stay in the adjusted position.

3. Backrest side bolster

The control should be easy to move to the inflate or deflate position and must return to neutral when released. Each side bolster should inflate and deflate evenly and stay at the adjusted firmness.

4. Height adjustment

Control should be easy to move and hold the seat in the adjusted position when released.

5. Horizontal adjustment

Control should be easy to move and hold the seat in the adjusted position when released.

6. Seat tilt adjustment

Control should be easy to move and hold the seat in the adjusted position when released.

7. Lower and upper lumbar support

The controls should be easy to move to the inflate or deflate position and must return to neutral when released. Each lumbar support must stay at the adjusted firmness.

8. Cushion length adjustment

Control should be easy to move and hold the seat cushion in the adjusted position when released.

9. Adjustable shock absorber

Control should be easy to move and stay in position when released.

10. Quick air release

Control should be easy to move and hold seat in the adjusted position when released.

11. Horizontal isolator

Control should be easy to move and stay in position when released.

12. Headrest

Should be easy to move up and down and stay in position. Headrest should tilt forward and backward freely.

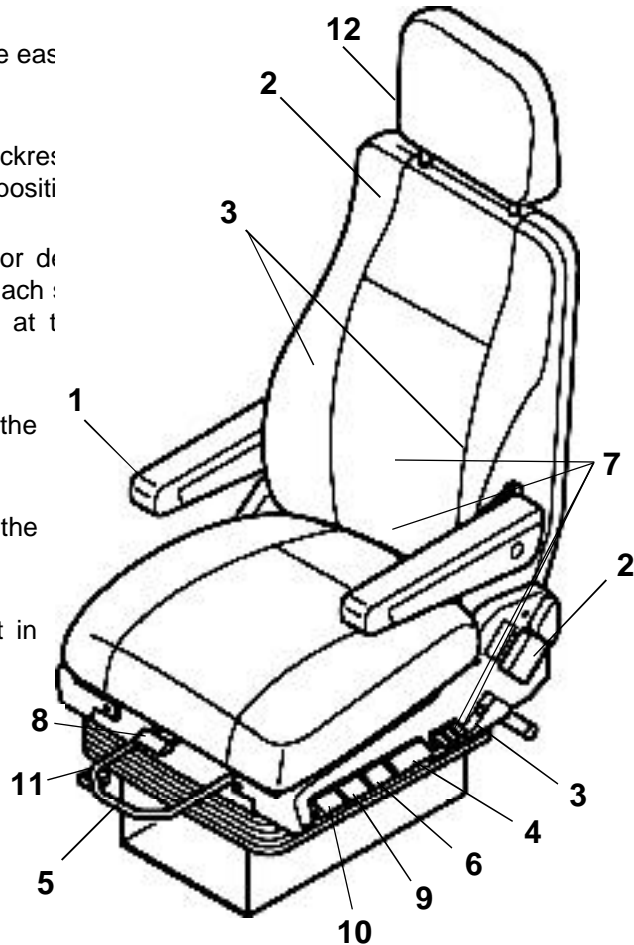

If the seat is not functioning properly take it out of service until it can be repaired.

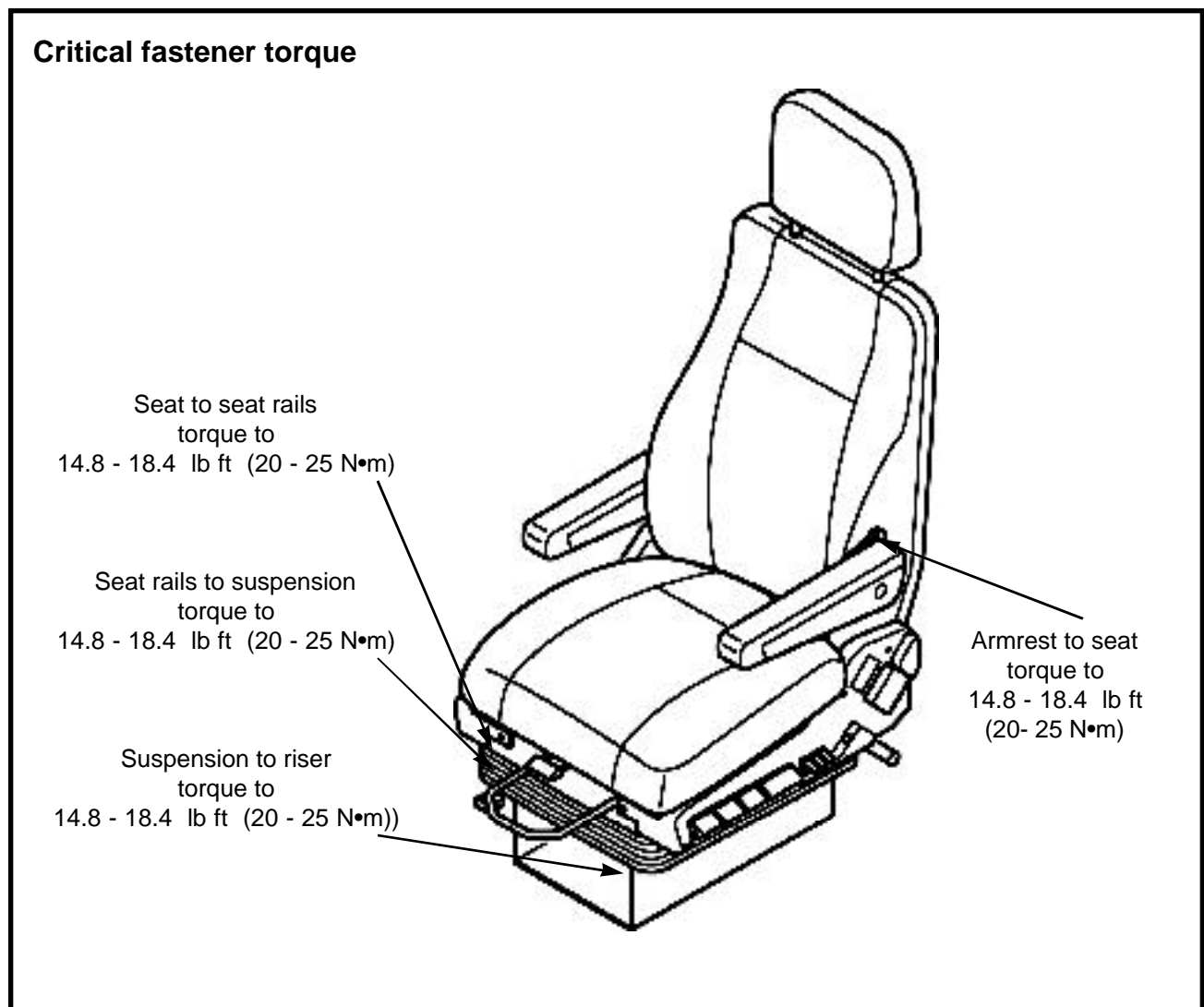
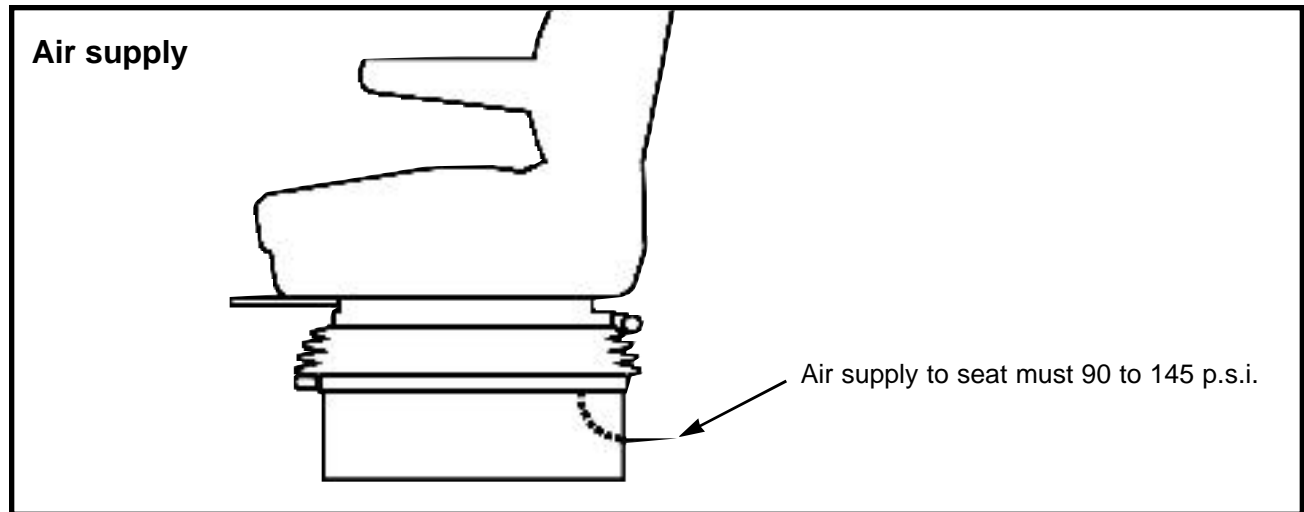

REMOVAL and INSTALLATION

MODEL 6800/338 BUS
MODEL 6800/338 PREMIUM LX



Avoid the risk of injury. Vehicle must be in a safe parked position before working on the seat.

NOTICE

To remove seat from vehicle follow vehicle manufacturer's instructions.

Armrest

Set up

- Vehicle must be in a safe parked position or seat removed from vehicle.

Removal

- Remove fasteners
- Remove armrest

Installation

- Fasten armrest to seat with screws and lockwashers.
- Torque screws to 14.8 - 18.4 lb ft (20 - 25 N•m)

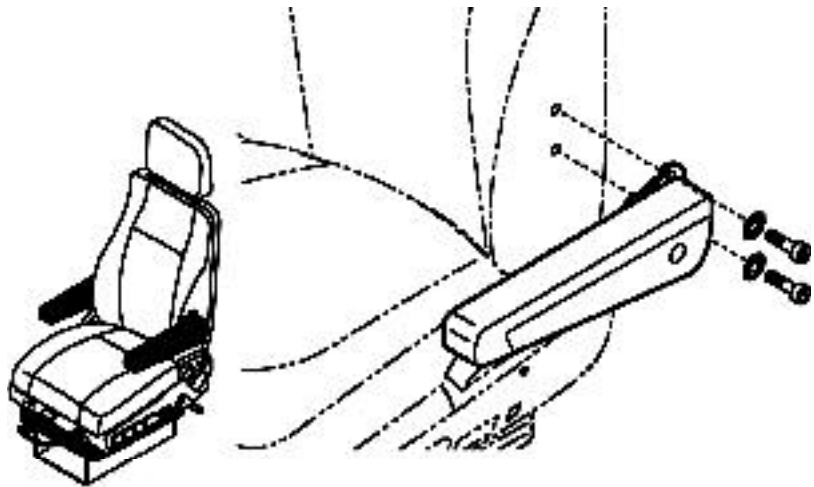

Backrest

Set up

- Vehicle must be in a safe parked position or seat removed from vehicle.

Removal

- Mark and disconnect air lines
- Remove fasteners
- Pry one side of seat frame away from backrest
- Remove backrest

Installation

- Put one side of backrest in place
- Pry other side of seat frame away and put backrest in place
- Fasten backrest to seat frame with shoulder bolts
- Torque shoulder bolts to 22 - 25.5 lb ft (30 - 35 N•m)
- Connect air lines

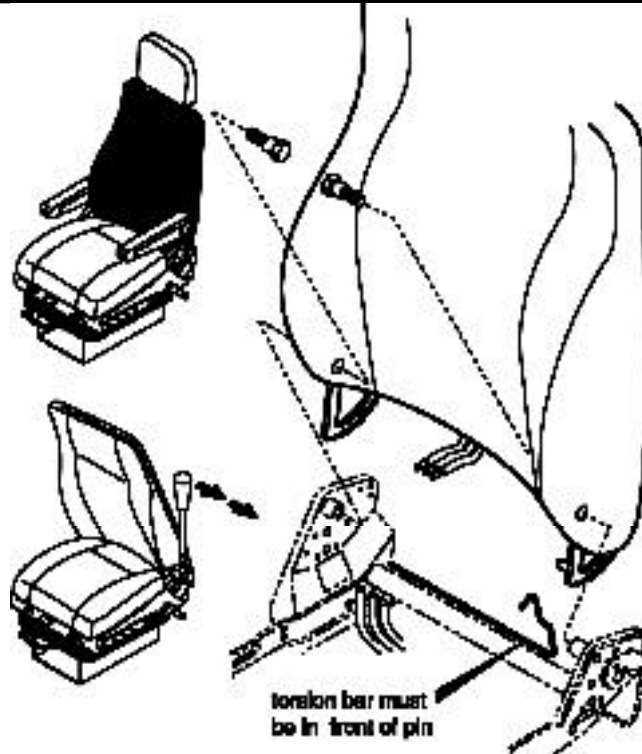

Backrest assembly

Set up

- Backrest must be removed from seat (see **Backrest**)

Removal

- Premium XL - remove upholstery and backrest liner
- Bus - remove cover, hog rings and wires.-- remove upholstery
- Remove backrest cushion fasteners -- remove cushion

Installation

- Fasten backrest cushion to backrest frame with screws
- Premium XL - install backrest liner and upholstery
- Bus - install upholstery, hog rings and wires.-- instal cover

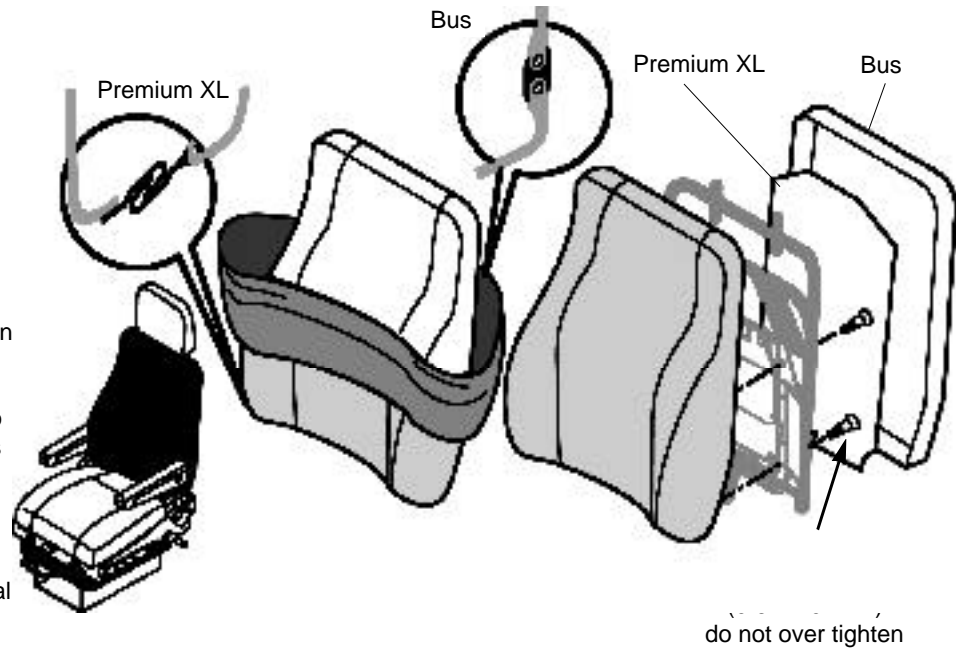

Lumbar and bolster air bags

Set up

- Remove backrest components (see **Backrest assembly**)

Removal

- Remove air bag clips, push fasteners and cable ties
- Remove air bags

Installation

- Fasten air bags to backrest frame with clips - put long clip arm over bar and snap bottom of clip in place
- Install push fasteners and cable ties

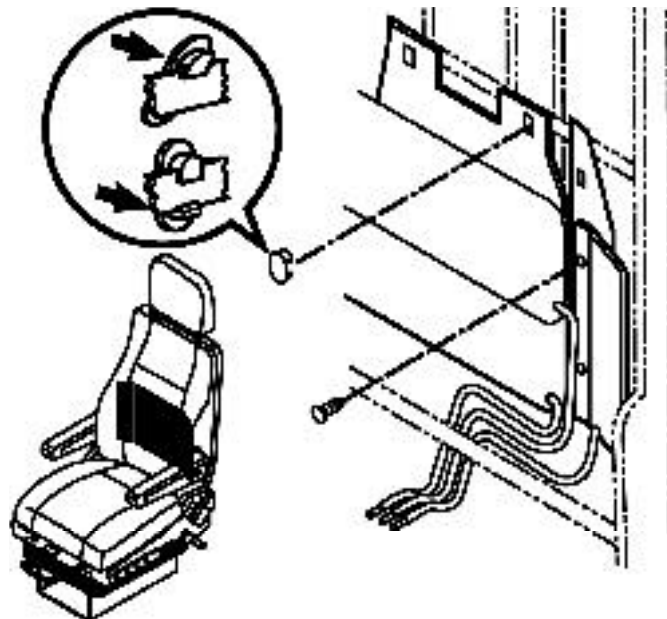

REMOVAL and INSTALLATION

MODEL 6800/338 BUS
MODEL 6800/338 PREMIUM LX

Lumbar and bolster valve

Set up

- Cover must be removed from seat (see **Covers front, LH and RH**)

Removal

- Mark air line and remove them from valve
- Press valve clips in and remove valve from cover

Installation

- Snap valve into cover
- Connect air lines

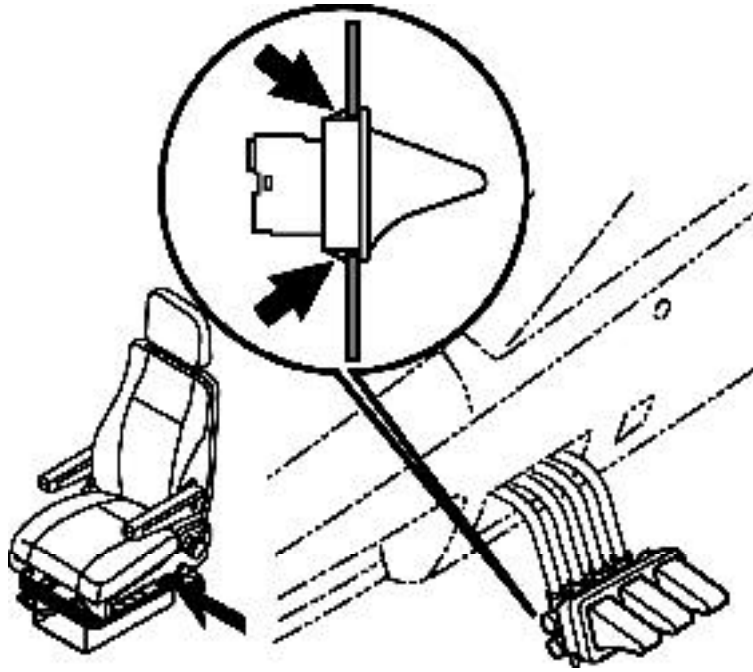

Covers, LH and RH

Set up

- Vehicle must be in a safe parked position or seat removed from vehicle.

Removal

Control cover

- Remove backrest adjustment handle
- Remove tilt adjustment handle - for fastener access
- Remove fasteners and cover

Non control cover

- Remove fasteners and cover

Installation

Control cover

- Fasten cover to seat frame with screws
- Install backrest adjustment handle
- Install tilt adjustment handle - removed for fastener access

Non control cover

- Fasten cover to seat frame with screws

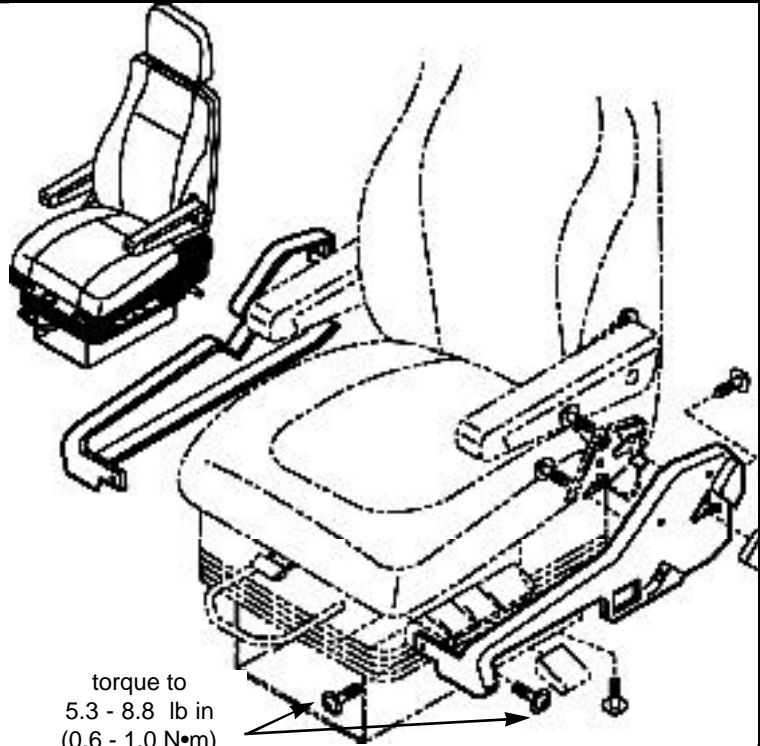

torque to
5.3 - 8.8 lb in
(0.6 - 1.0 N•m)
do not over tighten

Seat pan assembly

Set up

- Vehicle must be in a safe parked position or seat removed from vehicle.

Removal

- Slide cushion assembly forward
- Pry lever handle up to release cushion stop -- lift cushion off of glides

Installation

- Put seat cushion assembly on glides and slide back

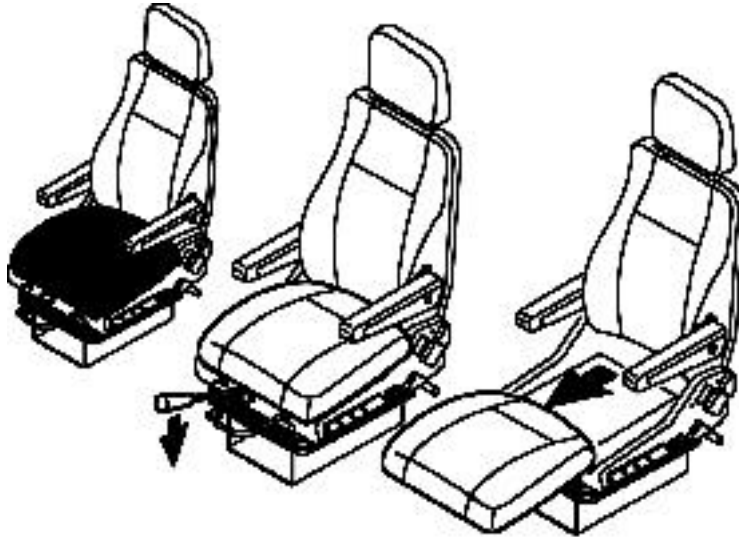

Glides - seat pan

Set up

- Seat cushion must be removed from seat (see **Cushion seat pan**)

Removal

- Remove cushion glides

Installation

- Install cushion glides to seat frame

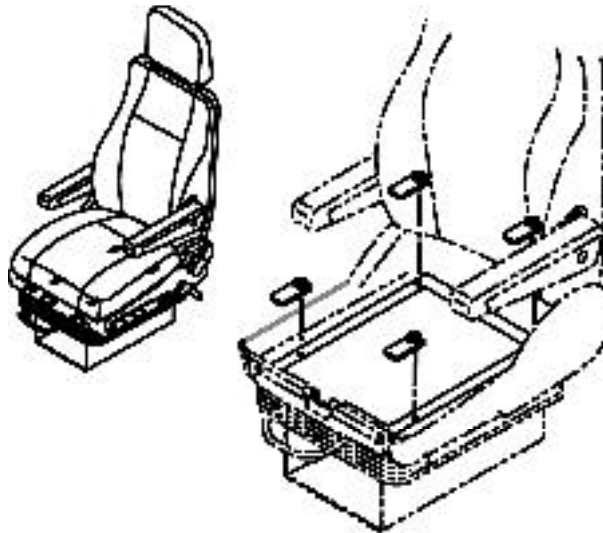

REMOVAL and INSTALLATION

MODEL 6800/338 BUS
MODEL 6800/338 PREMIUM LX

Seat pan assembly, lever and handle

Set up

- Seat cushion must be removed from seat (see **Cushion seat pan**)

Removal

- Pull handle off
- Remove lever fasteners and remove lever

Installation

- Align locator button of lever with hole in seat pan
- Fasten lever to seat pan with screw and washer
- Push handle on

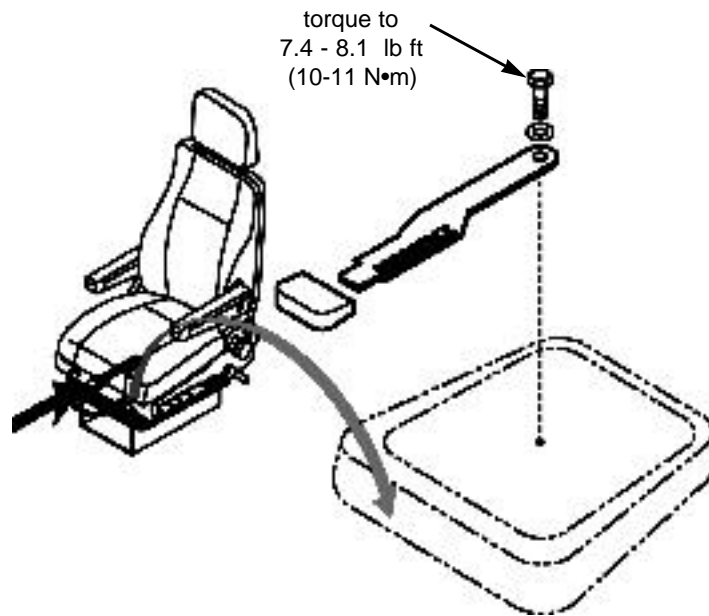

Height adjustment valve

Set up

- Seat cushion must be removed from seat (see **Cushion seat pan**)

Removal

- Mark and remove air lines from valve
- Remove valve fasteners
- * Remove valve

Installation

- Fasten valve to seat frame with screw
- Connect air lines

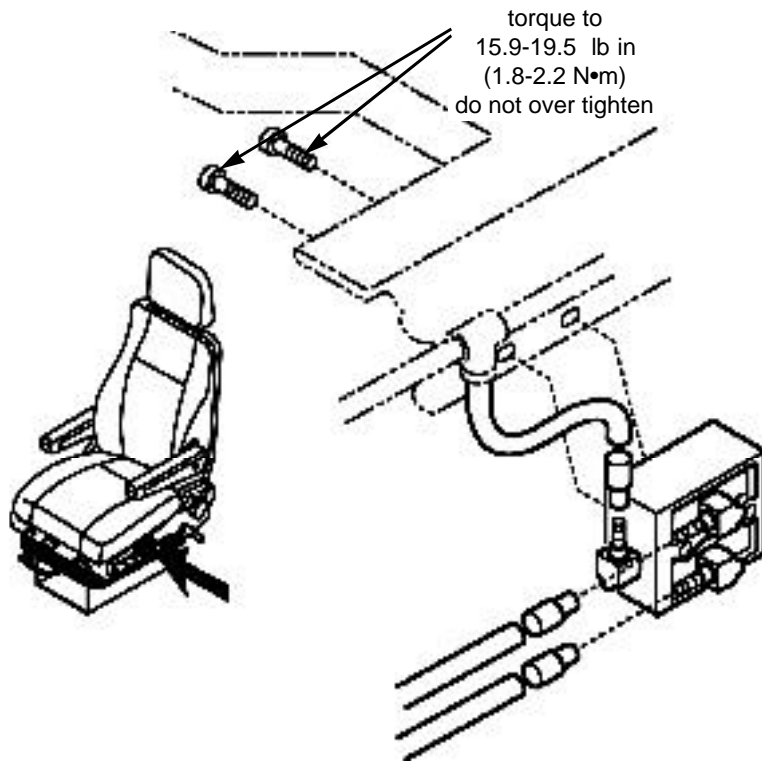

Height adjustment handle

Set up

- Vehicle must be in a safe parked position or seat removed from vehicle
- Control cover must be removed (see Covers front, LH and RH)

Removal

- Remove screw and cam
- Pull handle and lever out
- Remove retainers

Installation

- Put upper retainers in place
- Put lever in place
- Put lower retainers in place - be sure it snaps in place
- Install cam and screw
- Install handle

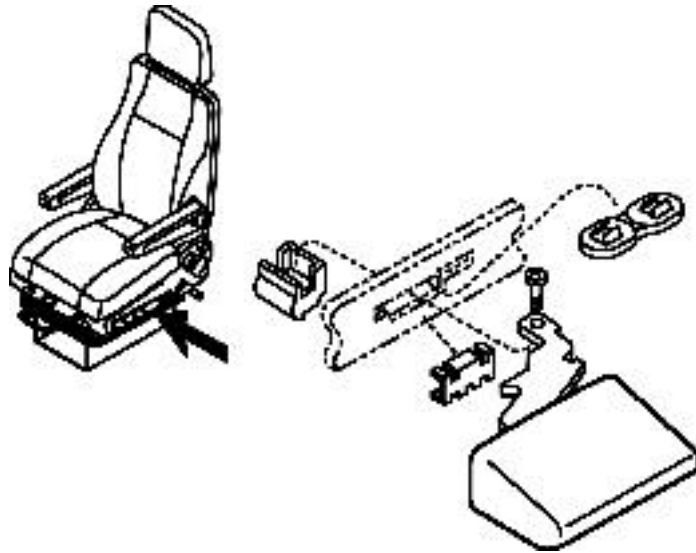

Height adjustment cylinder and cam

Set up

- Vehicle must be in a safe parked position or seat removed from vehicle
- Seat cushion must be removed from seat (see Cushion seat pan)

Removal

Air cylinder

- Remove base end pin and retainer washer - remove rod end fastener, air line, and remove cylinder

Cam

- Remove rod end fastener
- Remove E ring and mounting pin
- Remove cam

Installation

Air cylinder

- Put cylinder in place and install base end pin and retainer washer - install rod end fastener, connect air line

Cam

- Put cam in place and install pin and E ring

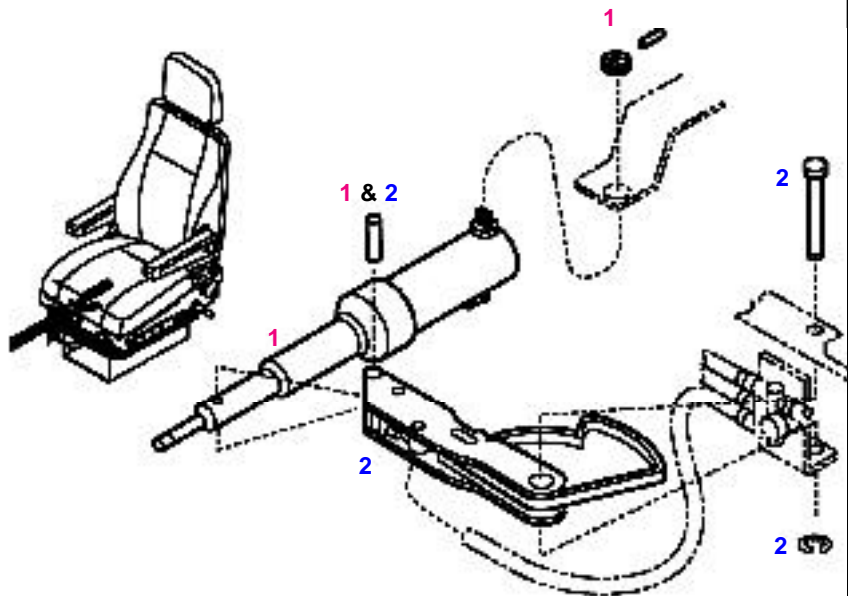

1 = Cylinder kit
2 = Cam kit

REMOVAL and INSTALLATION

MODEL 6800/338 BUS
MODEL 6800/338 PREMIUM LX

Horizontal adjustment slide set

Set up

- Seat frame must be removed (see **Seat frame**)

Removal

- Move horizontal adjustment forward or back to allow access to fasteners
- Remove mounting fasteners

Installation

- Move horizontal adjustment forward or back to allow access to fasteners
- Install mounting fasteners

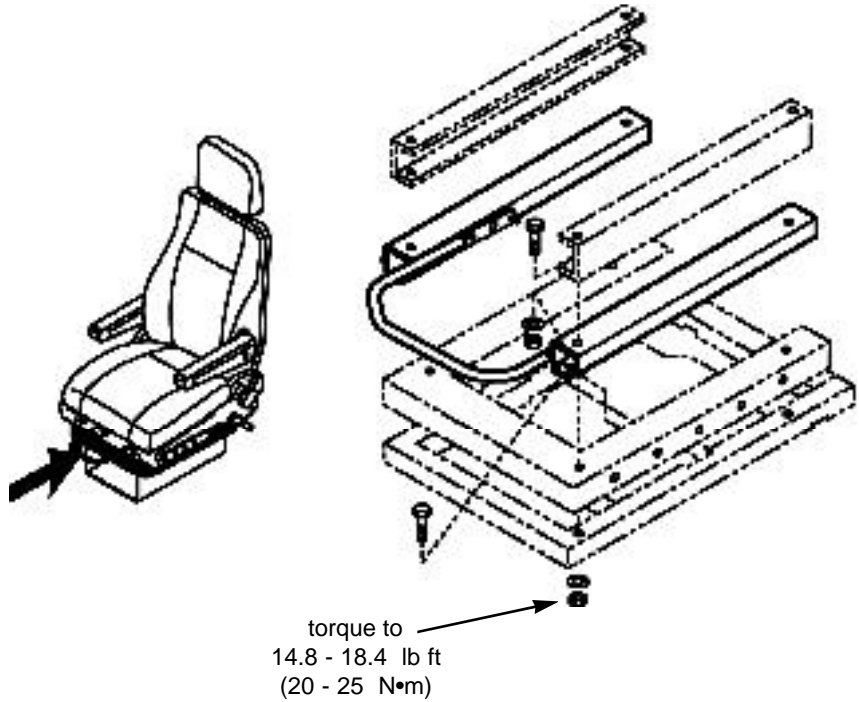

Quick air release - valve and handle LH and RH

Set up

- Seat cushion must be removed from seat (see **Cushion seat pan**)

Removal

- Mark and remove air lines from valve
- Remove valve fasteners
- Remove valve
- Remove valve handle pin and valve handle

Installation

- Fasten valve handle to valve with pin
- Fasten valve to seat frame with screw
- Connect air lines

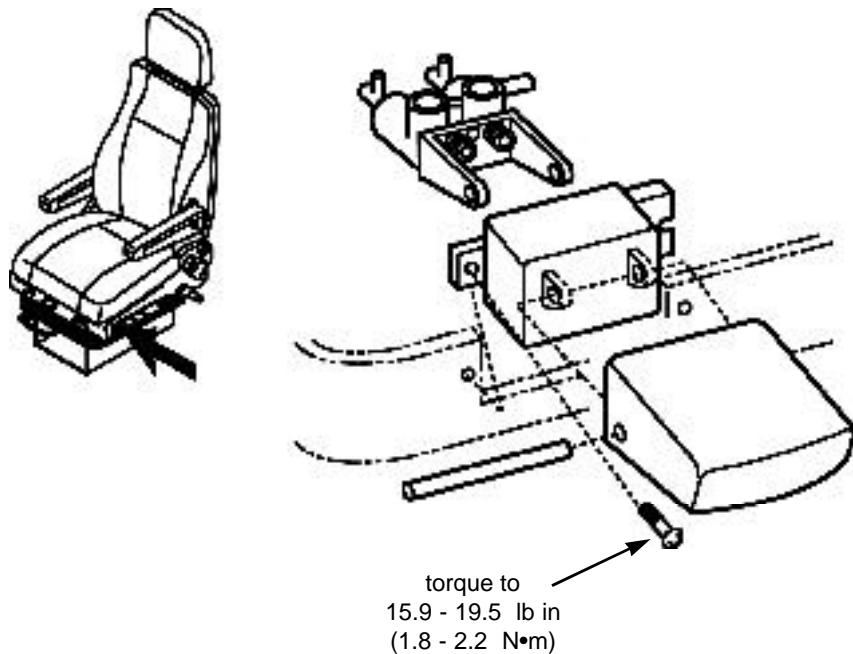

Quick air release valve - suspension

Set up

- Seat cushion must be removed from seat (see **Cushion seat pan**)

Removal

- Mark and remove air lines from valve
- Remove valve fasteners and remove valve

Installation

- Fasten valve to suspension with screws
- Connect air lines



torque to
15.9 - 19.5 lb in
(1.8 - 2.2 N•m)

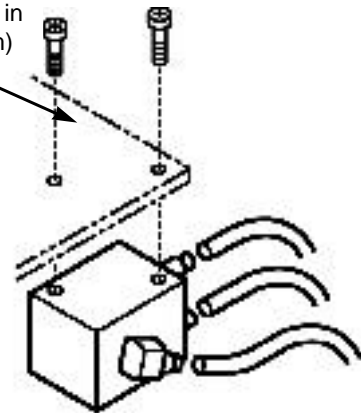

Riser and Suspension

Set up - riser and suspension

- Vehicle must be in a safe parked position or seat removed from vehicle.

Set up - suspension

- Boot, Boot adapter plate, ICP bar, and tethers must be removed (see **Boot, Boot adapter plate, ICP bar, and tethers**)

Removal - suspension

- Remove air line
- Remove suspension to riser fasteners and remove suspension

Installation - suspension

- Put suspension in place
- Install fasteners and torque to 14.8 - 18.4 lb ft (20 - 25 N•m)
- Connect air line

Removal - riser

- Remove riser to floor fasteners and remove riser

Installation - riser

- Put riser in place and install fasteners, torque to manufactures specification

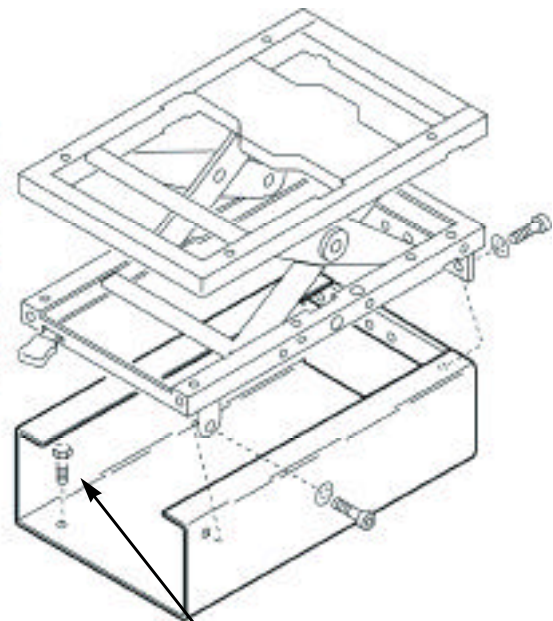

torque to
manufactures
recommendation

REMOVAL and INSTALLATION

MODEL 6800/338 BUS
MODEL 6800/338 PREMIUM LX

Seat frame

Set up

- Seat cushion and backrest must be removed from seat (see **Cushion seat pan and Backrest**)
- Shock absorber handle and cable must be removed. (see **Adjustable shock absorber handle and cable - handle end**)

Removal

- Mark and remove air lines
- Remove fasteners
- Remove seat frame

Installation

- Fasten seat frame to static spacer rails with bolts and nuts
- Torque fasteners to 14.8 - 18.4 lb ft (20 - 25 N•m)
- Connect air lines

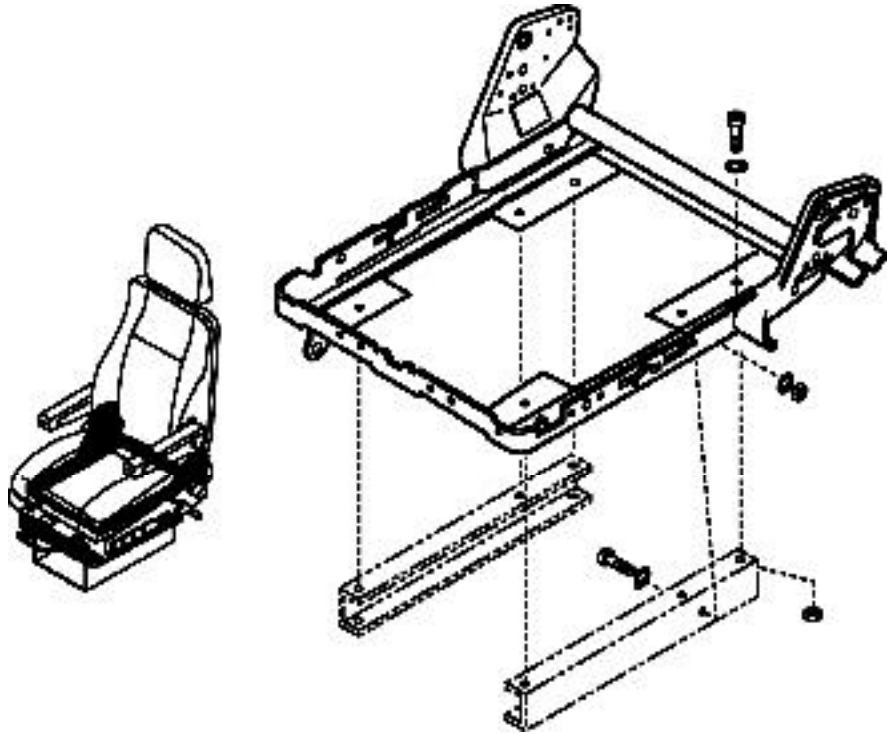

Seat frame tooth plate

Set up

- Backrest and covers must be removed from seat (see **Backrest and Covers front, LH and RH**)

Removal

- Remove seat latch fasteners
- Remove seat latch
- Remove connecting link

Installation

- Install connecting link
- Fasten seat latch to seat frame with screws

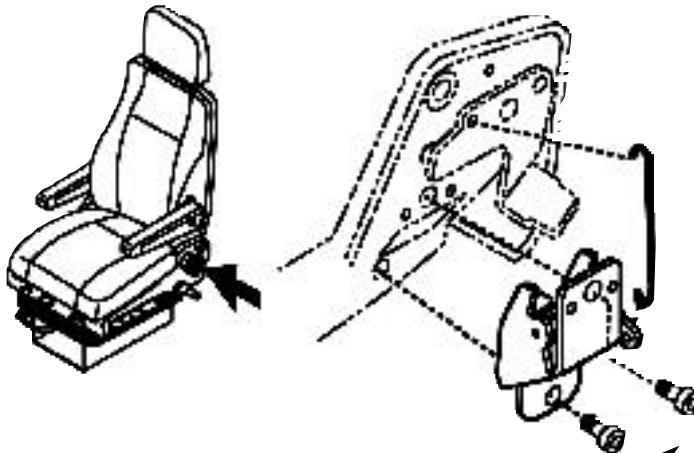

torque to
14.8 - 18.4 lb ft
(20 - 25 N•m)

Backrest adjustment handle

Set up

- Vehicle must be in a safe parked position or seat removed from vehicle.

Removal

- Pull handle off

Installation

- Push handle on

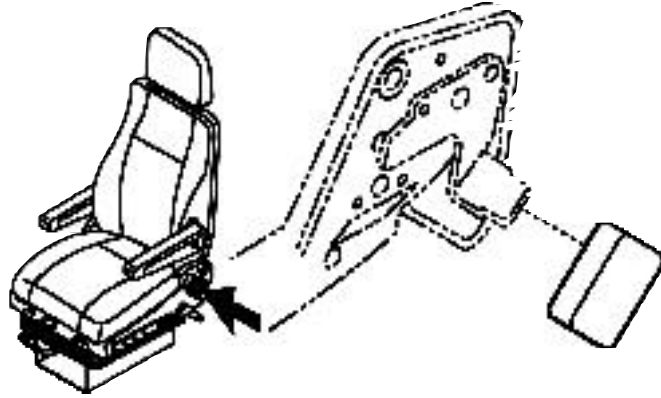

Tilt handle

Set up

- Vehicle must be in a safe parked position or seat removed from vehicle.

Removal

- Remove springs
- Pull handle and lever out
- Remove retainer

Installation

- Put lever in place
- Install retainer, be sure it snaps in place
- Install springs
- Install handle

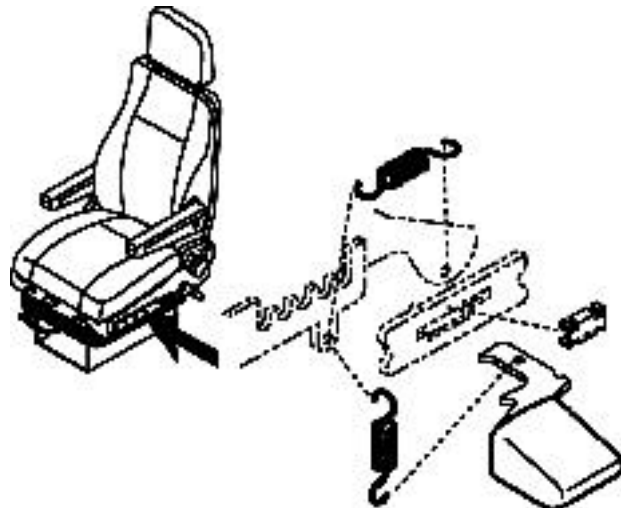

REMOVAL and INSTALLATION

MODEL 6800/338 BUS
MODEL 6800/338 PREMIUM LX

Air spring

Set up

- Seat must be removed from vehicle
- Seat cushion must be removed from seat (see **Cushion seat pan**)

Removal

- Mark and disconnect air line
- Remove top and bottom mounting fasteners
- Remove air spring

Installation

- Put air spring in place
- Install top and bottom mounting fasteners
- Connect air line

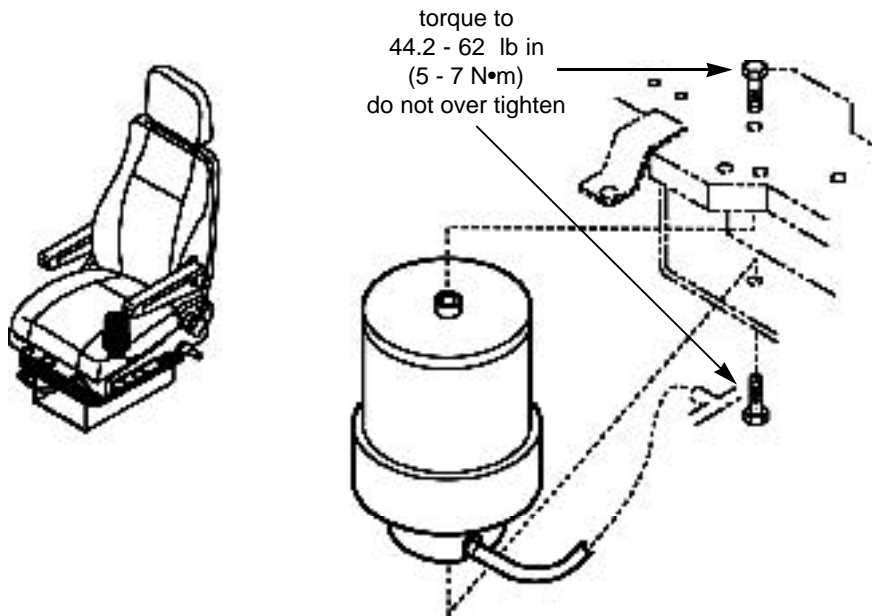

Boot, Boot adapter plate ICP bar, and tethers

Set up

- Vehicle must be in a safe parked position or seat removed from vehicle
- Horizontal adjustment must be removed (see **Horizontal adjustment**)

Removal

- Remove belts from ICP bar
- Remove boot fasteners, remove boot, and boot adapter plate
- Remove fasteners, tether plate, tether brackets, tethers, and ICP bar

Installation

- Install fasteners, tether plate, tether brackets, tethers, and ICP bar
- Install boot adapter plate, boot, and fasteners
- Install belts to ICP bar

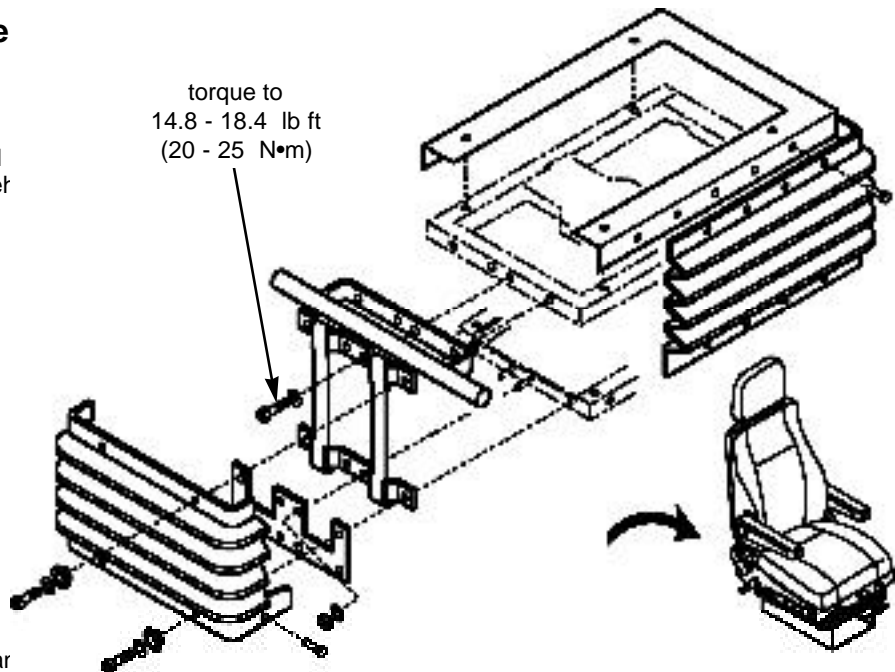

Adjustable shock absorber handle and cable (handle end)

Set up

- Seat cushion must be removed from seat (see **Cushion seat pan**)

Removal

- Remove fasteners and move control, bracket, and cable up away from seat frame
- Remove control handle pin and control handle
- Remove cable pin and cable
- Remove plug from bracket and remove cable

Installation

- Put cable in bracket and secure plug
- Route cable through control bracket and fasten to control handle with pin
- Fasten control handle to control bracket with pin
- Fasten control and bracket to frame with screws

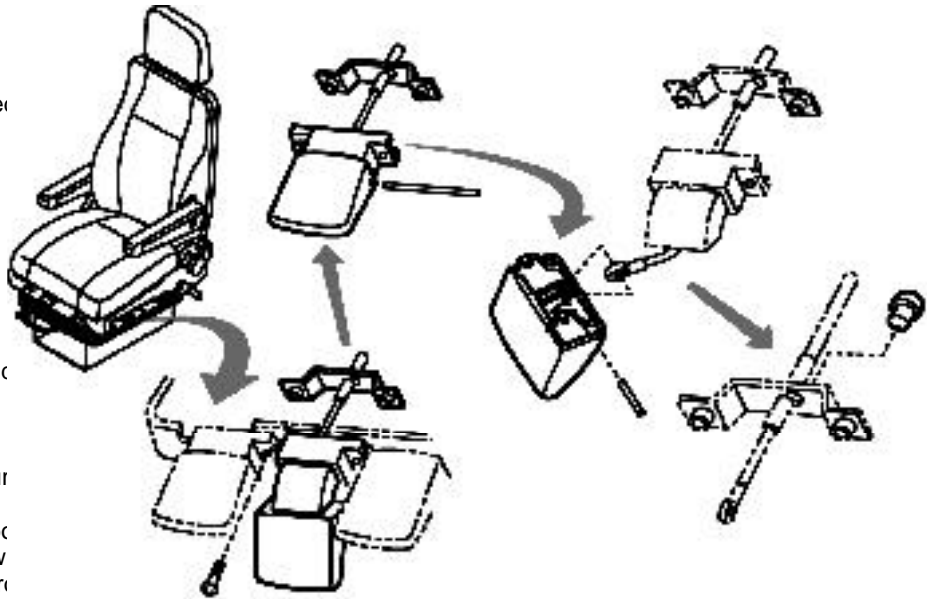

Adjustable shock absorber and cable (shock absorber end)

Set up

- Vehicle must be in a safe parked position or seat removed from vehicle
- Seat cushion must be removed from seat (see **Cushion seat pan**)

Removal

Adjustable shock absorber

- Remove retaining rings
- Remove shock absorber

Adjustable shock absorber cable

- Remove retaining ring
- Remove cable

Installation

Adjustable shock absorber cable

- Put cable in place
- Install retaining ring

Adjustable shock absorber

- Put shock absorber in place
- Install retaining rings

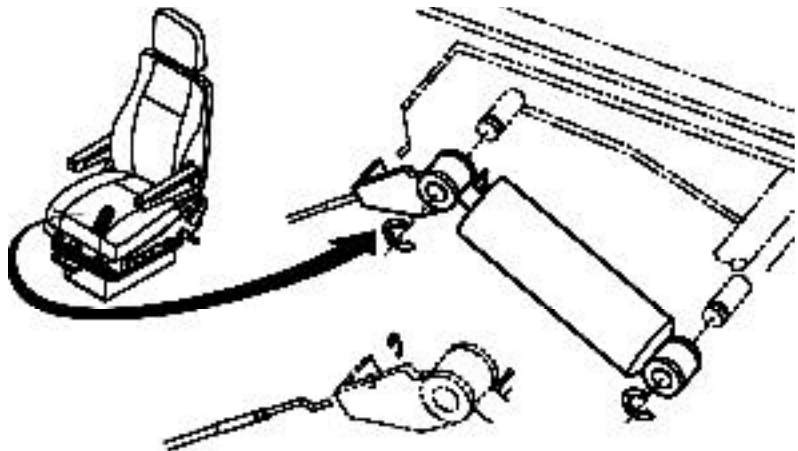

REMOVAL and INSTALLATION

MODEL 6800/338 BUS
MODEL 6800/338 PREMIUM LX

Distribution valve

Set up

- Seat cushion must be removed from seat (see **Cushion seat pan**)

Removal

- Mark and remove air lines from valve
- Remove valve fastener and remove valve

Installation

- Fasten valve to frame with screw
- Connect air lines

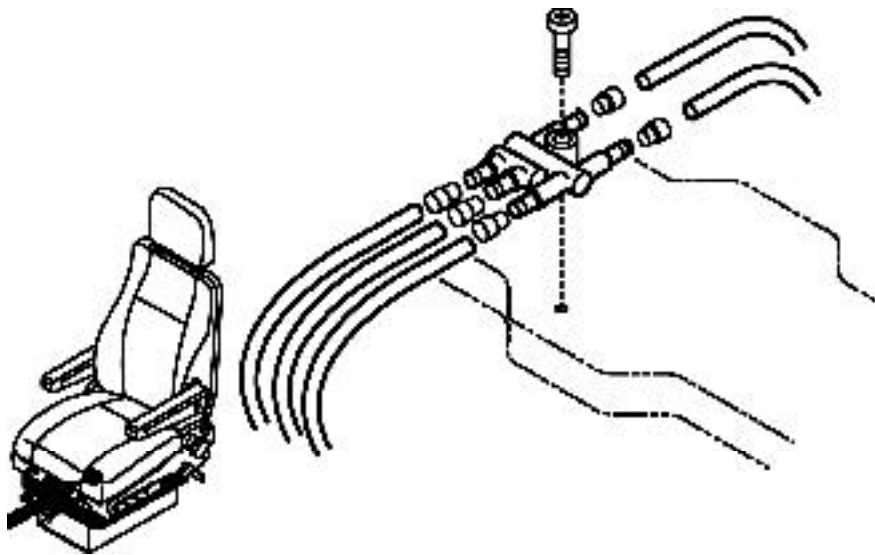

Headrest

Set up

- Vehicle must be in a safe parked position or seat removed from vehicle

Removal

- Pull headrest to upper locking position
- Press foam, as shown, to release locking clip from detent on headrest and pull up

Installation

- Guide headrest bars into position
- Press down to engage locking clip

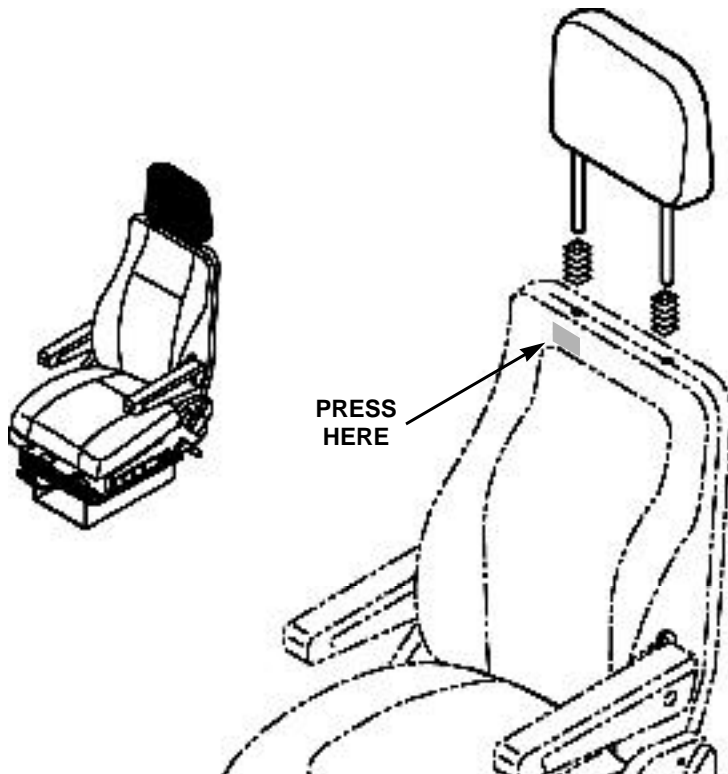

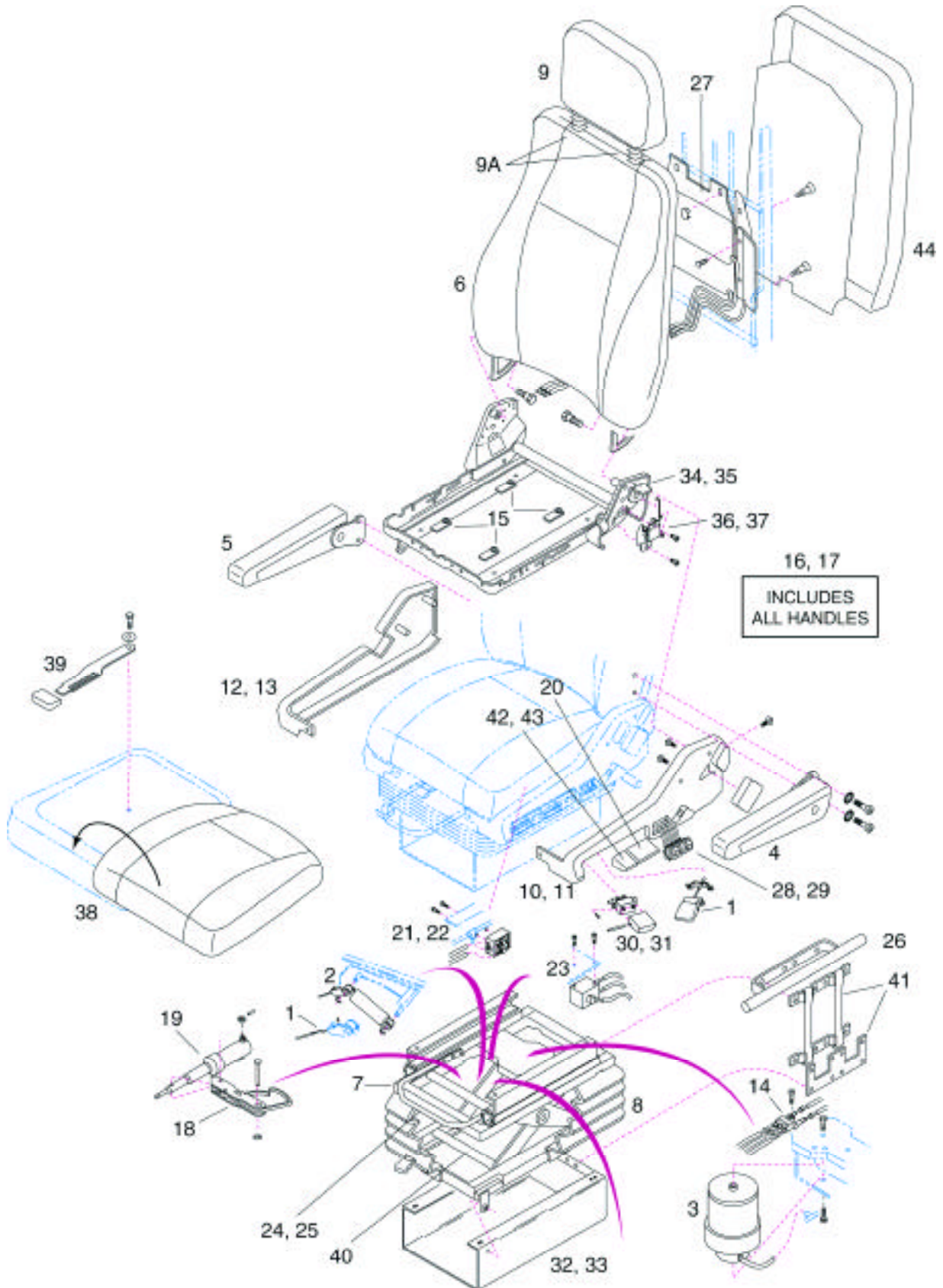

REMOVAL and INSTALLATION

MODEL 6800/338 BUS

item	part number	description
1	910353-11	ADJUSTABLE SHOCK ABSORBER CABLE KIT - YS (WAS 910353-09)
2	98889-06	ADJUSTABLE SHOCK ABSORBER KIT
3	98872-15	AIR SPRING KIT
4	924473-32	ARMREST KIT - LH - YEL - W/O UPH
5	924474-32	ARMREST KIT - RH - YEL - W/O UPH
6	03003-00	BACKREST ASM - BUS - NUDE
7	111776P02	BOOT ADAPTER PLATE
8	926513-01	BOOT KIT
9	110922-00	HEADREST ASM - NUDE
9A	47541	HEADREST BOOT
10	920260-04	COVER KIT - CONTROL - LH - W/IPS - FOR HTR - YS (W/LOGO)
10	920260-07	COVER KIT - CONTROL - LH - W/IPS - FOR W/O HTR - YS (W/LOGO)
10	927399-01	COVER KIT - CONTROL - LH - W/IPS - FOR HTR - YS (W/O LOGO)
10	927399-02	COVER KIT - CONTROL - LH - W/IPS - FOR W/O HTR - YS (W/O LOGO)
11	920263-04	COVER KIT - CONTROL - RH - W/IPS - FOR HTR - YS (W/LOGO)
11	920263-05	COVER KIT - CONTROL - RH - W/IPS - FOR W/O HTR - YS (W/LOGO)
11	927398-01	COVER KIT - CONTROL - RH - W/IPS - FOR HTR - YS (W/O LOGO)
11	927398-02	COVER KIT - CONTROL - RH - W/IPS - FOR W/O HTR - YS (W/O LOGO)
12	920262-03	COVER KIT - NON-CONTROL - LH (W/LOGO) (WAS 920262-01)
12	920262-02	COVER KIT - NON-CONTROL - LH (W/O LOGO)
12	927397-01	COVER KIT - NON-CONTROL - LH - BELT TO FRAME (W/LOGO)
12	927397-02	COVER KIT - NON-CONTROL - LH - BELT TO FRAME (W/O LOGO)
13	920261-03	COVER KIT - NON-CONTROL - RH (W/LOGO) (920261-01)
13	920261-02	COVER KIT - NON-CONTROL - RH (W/O LOGO)
13	927396-01	COVER KIT - NON-CONTROL - RH - BELT TO FRAME (W/LOGO)
13	927396-02	COVER KIT - NON-CONTROL - RH - BELT TO FRAME (W/O LOGO)
14	915105-03	DISTRIBUTION VALVE KIT
15	914516-04	GLIDE KIT - SEAT PAN
16	920264-03	HANDLE KIT - SEAT FRAME - LH - YS
17	920264-03	HANDLE KIT - SEAT FRAME - RH - YS
18 & 19	933649-01	HEIGHT ADJUSTMENT CYLINDER/CAM KIT
20	920266-05	HEIGHT ADJUSTMENT HANDLE KIT - LH - YS
20	920266-06	HEIGHT ADJUSTMENT HANDLE KIT - RH - YS
21	98976-08	HEIGHT ADJUSTMENT VALVE KIT - LH (WAS 98976-07)
22	98875-08	HEIGHT ADJUSTMENT VALVE KIT - RH (WAS 98875-07)
23	98873-01	HEIGHT ADJUSTMENT VALVE KIT - SUSPENSION (WAS 98873)
24	24569F	HORIZONTAL ADJUSTMENT SLIDE HANDLE - YEL
25	18755-02	HORIZONTAL ADJUSTMENT SLIDE SET - YEL
26	111895P01	ICP BAR - BUS (FOR BELT TO ICP BAR ONLY)
27	920272-01	LUMBAR/BOLSTER KIT (OLD STYLE)
27	920272-04	LUMBAR/BOLSTER KIT (NEW STYLE)
28	36571-01	LUMBAR/BOLSTER VALVE - LH - YS
29	36572-01	LUMBAR/BOLSTER VALVE - RH - YS
30	914514-29	QUICK AIR RELEASE VALVE AND HANDLE KIT - LH - YS (WAS 914514-24)
31	914514-30	QUICK AIR RELEASE VALVE AND HANDLE KIT - RH - YS (WAS 914514-25)
32	03007P	RISER - 127 MM (MCI "D-SERIES & G-SERIES" COACH)
32	03463P	RISER - 127 MM (STD BUS, NEOPLAN, ORION VI, NEW FLYER, GILLIG)
32	03013P	RISER - 156 MM (MCI "E-SERIES & J-SERIES" COACH)
32	03468	RISER KIT - 76 MM (PREVOST COACH)
34	03307-01	SEAT FRAME ASM - LH - YS
35	03308-01	SEAT FRAME ASM - RH - YS
36	914500-27	SEAT FRAME TOOTH PLATE KIT - LH (WAS 914500-23)
37	914500-28	SEAT FRAME TOOTH PLATE KIT - RH (WAS 914500-24)
38	03002-00	SEAT PAN ASM - NUDE - YEL (OLD STYLE)
38	03576-00	SEAT PAN ASM - NUDE - YEL (NEW STYLE)
39	921845-02	SEAT PAN ASSEMBLY LEVER AND HANDLE KIT - YEL
40	111833-01	SUSPENSION ASM - W/ISOLATOR - YS
41	924464-01	TETHER (INTERNAL) AND TETHER PLATE KIT
42	920267-05	TILT HANDLE KIT - LH - YS
43	920267-06	TILT HANDLE KIT - RH - YS
44	920270-02	BACKREST PANEL KIT (BUS ONLY) (WAS 01955-03)
45	95477-05	SUSPENSION HARDWARE KIT
46	96099-01	CAM GUIDE BRACKET KIT

REMOVAL and INSTALLATION

MODEL 6800/338 PREMIUM LX

item	part number	description
1	910353-13	ADJUSTABLE SHOCK ABSORBER CABLE KIT - GS
2	98889-06	ADJUSTABLE SHOCK ABSORBER KIT
3	98872-15	AIR SPRING KIT
4	924473-51	ARMREST KIT - LH - GRY - W/O UPH
5	924474-51	ARMREST KIT - RH - GRY - W/O UPH
6	03483-00	BACKREST ASM - TRUCK - NUDE
7	111776P02	BOOT ADAPTER PLATE
8	926513-01	BOOT KIT
9	110922-00	HEADREST ASM - NUDE
9A	47541	HEADREST BOOT
10	920260-08	COVER KIT - CONTROL - LH - W/IPS - FOR HTR - GS (W/LOGO)
10	920260-09	COVER KIT - CONTROL - LH - W/IPS - FOR W/O HTR - GS (W/LOGO)
10	927399-03	COVER KIT - CONTROL - LH - W/IPS - FOR HTR - GS (W/O LOGO)
10	927399-04	COVER KIT - CONTROL - LH - W/IPS - FOR W/O HTR - GS (W/O LOGO)
11	920263-06	COVER KIT - CONTROL - RH - W/IPS - FOR HTR - GS (W/LOGO)
11	920263-07	COVER KIT - CONTROL - RH - W/IPS - FOR W/O HTR - GS (W/LOGO)
11	927398-03	COVER KIT - CONTROL - RH - W/IPS - FOR HTR - GS (W/O LOGO)
11	927398-04	COVER KIT - CONTROL - RH - W/IPS - FOR W/O HTR - GS (W/O LOGO)
12	920262-03	COVER KIT - NON-CONTROL - LH (W/LOGO) (WAS 920262-01)
12	920262-02	COVER KIT - NON-CONTROL - LH (W/O LOGO)
12	927397-01	COVER KIT - NON-CONTROL - LH - BELT TO FRAME (W/LOGO)
12	927397-02	COVER KIT - NON-CONTROL - LH - BELT TO FRAME (W/O LOGO)
13	920261-03	COVER KIT - NON-CONTROL - RH (W/LOGO) (WAS 920261-01)
13	920261-02	COVER KIT - NON-CONTROL - RH (W/O LOGO)
13	927396-01	COVER KIT - NON-CONTROL - RH - BELT TO FRAME (W/LOGO)
13	927396-02	COVER KIT - NON-CONTROL - RH - BELT TO FRAME (W/O LOGO)
14	915105-03	DISTRIBUTION VALVE KIT
15	914516-04	GLIDE KIT - SEAT PAN
16	920264-01	HANDLE KIT - SEAT FRAME - LH - GS
17	920264-02	HANDLE KIT - SEAT FRAME - RH - GS
18 & 19	933649-01	HEIGHT ADJUSTMENT CYLINDER/CAM KIT
20	920266-01	HEIGHT ADJUSTMENT HANDLE KIT - LH - GS
20	920266-02	HEIGHT ADJUSTMENT HANDLE KIT - RH - GS
21	98976-08	HEIGHT ADJUSTMENT VALVE KIT - LH (WAS 98976-07)
22	98875-08	HEIGHT ADJUSTMENT VALVE KIT - RH (WAS 98875-07)
23	98873-01	HEIGHT ADJUSTMENT VALVE KIT - SUSPENSION (WAS 98873)
24	26900D01	HORIZONTAL ADJUSTMENT SLIDE HANDLE - BLK
25	18755-04	HORIZONTAL ADJUSTMENT SLIDE SET - BLK
26	111973P02	ICP BAR - TRUCK
27	920272-01	LUMBAR/BOLSTER KIT (OLD STYLE)
27	920272-04	LUMBAR/BOLSTER KIT (NEW STYLE)
28	36571	LUMBAR/BOLSTER VALVE - LH - GS
29	36572	LUMBAR/BOLSTER VALVE - RH - GS
30	914514-28	QUICK AIR RELEASE VALVE AND HANDLE KIT - LH - GS
31	914514-31	QUICK AIR RELEASE VALVE AND HANDLE KIT - RH - GS
33	111779P03	RISER - 127 MM (KW W900 & T2000, MACK, INTERNATIONAL)
33	112256P02	RISER - 110 MM (PB 379 & 387)
33	110933P01	RISER - 76 MM (KW, PB, MACK, INTERNATIONAL)
34	03307-02	SEAT FRAME ASM - LH - GS
35	03308-02	SEAT FRAME ASM - RH - GS
36	914500-27	SEAT FRAME TOOTH PLATE KIT - LH (WAS 914500-23)
37	914500-28	SEAT FRAME TOOTH PLATE KIT - RH (WAS 914500-24)
38	03002-04	SEAT PAN ASM - NUDE - GRY (OLD STYLE)
38	03576-01	SEAT PAN ASM - NUDE - GRY (NEW STYLE)
39	921845-03	SEAT PAN ASSEMBLY LEVER AND HANDLE KIT - GRY
40	111833-08	SUSPENSION ASM - W/ ISOLATOR - GS
41	924464-01	TETHER (INTERNAL) AND TETHER PLATE KIT
42	920267-01	TILT HANDLE KIT - LH - GS
43	920267-02	TILT HANDLE KIT - RH - GS
45	95477-05	SUSPENSION HARDWARE KIT
46	96099-01	CAM GUIDE BRACKET KIT