

# *Skypport Services*

Toll Free Order Line  
1-800-624-5312



Technical Support  
518-797-3064

Order 24 hours a day  
Email- [sales@skypportservices.net](mailto:sales@skypportservices.net)

Or By

Fax: 518-797-3865  
4996 Delaware Tnpk  
P.O. Box 249  
Rensselaerville, NY 12147

## **TERMS and CONDITIONS**

*Our office will be staffed from 0800 to 1630 ET, Monday thru Friday. We have a toll-free number, 1-800-624-5312. We accept MasterCard or Visa. We will ship all ground packages UPS unless other instructions are requested. Packages being shipped Air Express will be shipped Via Federal Express or UPS, which ever is least expensive. If you are in the Midwest area, you are welcome to fly in or drive in to the Fox River Airport (96C), Rochester, WI.*

*Prices are FOB shipping point. Terms are cash with order, credit card, or COD. Additional handling/packing fees will be added for oversize and fragile items. Canadian orders require 20% (\$11.00 min.) for shipping/handling. (prices are for ground UPS shipments. Canadian orders are also subject to Brokerage/Custom fees charged by Canadian Authorities. Air Shipment Orders require an additional charge.) We CANNOT ship COD to Canada. Sales tax is applicable in Wisconsin. Some parts are subject to an additional CORE charge. Full refund of CORE charge is based on a part that can be rebuilt as determined by the approved Repair Station/Vendor.*

**HOW TO ORDER:** Please be sure to include with your order:

- A. **Your Complete Address** with zip code - a street address is necessary for UPS delivery and a phone number where you can be reached during the day for delivery or if there is a problem with your order.
- B. Model, Serial Number, and "N" Number or CF registry of the aircraft. This information is **MANDATORY WHEN ORDERING AN STC'D ITEM!**
- C. **Part Number**, Full Description, LH or RH (from pilot's position) if applicable, and the quantity needed.
- D. Method of Payment - check, Money Order, credit card, or we will automatically ship COD. Sorry - we CANNOT ship COD to Canada or any other non United States Territory. Your credit card statement will show charges to "Fox River Aviation/SS".

There is a \$15.00 minimum on each order (shipping not included) and a \$5.00 minimum shipping charge for all shipments. There is also a \$6.75 charge for any COD shipments. Orders placed before 11:00 am Eastern Time will normally be shipped the same day. These items are indicated in this price list with a "(OS)" symbol. "(OST)" indicates TRUCK Freight only. On orders requested or requiring truck shipping, customer relieves shipper of any responsibility for any damage incurred in transit. It is the customer's responsibility to file any claim with the freight company.

Please inspect all items upon receipt. If for any reason you are not satisfied with your parts, please contact us promptly for credit authorization. NO refunds on electrical components.

**ALL RETURNS MUST BE MADE WITHIN 30 DAYS OF RECEIPT AND MUST INCLUDE A COPY OF THE ORIGINAL INVOICE AND REASON FOR RETURN. THERE IS A 20% RESTOCKING CHARGE ON ALL RETURNS.**

**OUR SHIPPING ADDRESS IS:**

Skyport Aircoupe Services, Attn: John Cooper  
P.O. Box 249  
4996 Delaware Tnpk  
Rensselaerville, NY 12147

**Price list catalogs are updated annually in July  
ALL PRICES ARE SUBJECT TO CHANGE AT ANYTIME WITHOUT NOTICE**

*Revision Date: May 2005*

**TABLE OF CONTENTS**  
**MAY 2005**

The appended price list catalog covers the most frequently required parts, kits, and literature. If what you need is not included, please let us know. We will probably have it in stock or be able to locate it for you.

<u>SECTIONS</u>	<u>DESCRIPTION</u>	<u>PAGE</u>
1	AIRCRAFT GENERAL and MISCELLANEOUS INCLUDES: Model Conversions, Decals, Placards, Manuals- Publications and Miscellaneous Supplies.	1
2	CENTER SECTION / MAIN SPAR	3
3	ELECTRICAL / LIGHTING Landing Lights, Navigation Lights, Strobes and Miscellaneous.	4
4	ENGINE / ENGINE ACCESSORIES / PROPELLER	8
5	FUEL / OIL SYSTEMS	12
6	FUSELAGE / COWLING / CABIN	16
7	MAIN LANDING GEAR / BRAKES	19
8	NOSE LANDING GEAR / STEERING	22
9	FLIGHT CONTROLS and SURFACES Elevators, Stabilizers, Fins, Rudders, Wings, Ailerons, Cockpit Controls	24
10	WINDOWS / WINDSHIELDS / CANOPY	26

**Watch for MONTHLY SKYPORT SPECIALS on our NEW OLD STOCK (NOS) ITEMS. Excellent USED PARTS are always available at 50% OFF LIST!!! We also BUY USED PARTS. Call for details.**

**SKYPORT SERVICES STC INDEX**

<u>PART NUMBER</u>	<u>DESCRIPTION</u>	<u>PAGE</u>
SMK15	LARGE BAGGAGE COMPARTMENT (SA330GL-SA331GL)	16
SMK49	O-200 ENGINE (SA2628WE)	8
SMK 61	MLG OLEO STRUT SEAL (SA01247CH)	19 – FAA-PMA
SMK63/64 (Revised)	WHEEL FAIRINGS (SA1180GL) SN 813 & ABOVE	19/21 – FAA-PMA
SMK65/66	WHEEL FAIRINGS (SA2185WE) SN 812 & BELOW	19/21
SMK 67	WHEEL FAIRINGS – SPRING STEEL MLG (SA2230WE)	19/21
SMK 68/69	15 GALLON WING TANK Set (SA1492GL) 415/F1	12/14/15 – FAA-PMA
SMK 70/71	15 GALLON WING TANK Set (SA1484GL) A2/M10	12/14/15 – FAA-PMA
SMK 72/73	FIBERGLASS NOSE BOWL – (SA3502WE – SA3503WE)	16 & Back Cover
SMK 88	MASTER BRAKE CYLINDER (SA01407CH)	19
SMK 96	GASCOLATOR – METAL BOWL (SA01246CH)	12 – FAA-PMA
SMK 98	BRAKE RESERVOIR (SA01409CH)	19 – FAA-PMA
SMK 101/101F	WING LANDING LIGHT (SA1098GL – SA1097GL)	4

**NOTE: Please provide the AIRCRAFT MODEL, SERIAL NUMBER, and "N" NUMBER when ordering any STC'D ITEM.**

**AIRCRAFT GENERAL and MISCELLANEOUS ITEMS**

<u>PART NUMBER</u>	<u>DESCRIPTION</u>	<u>PRICE</u>
<b>A.</b>	<b><u>KITS and MODIFICATIONS</u></b>	<b>OS (OVERSIZE SHIPMENT)</b>
SMK 46*	Model 415-D CONVERSION (less trim tab) with STAINLESS COWL SKIN. Wide trim tab plate (PN 22031-4) if needed is extra .....	(OS) \$ 123.75
SMK 47*	Model 415-D CONVERSION with SMK 46, SMK-1 (Trim control conversion) and Trim Tab Assembly (22031).....	(OS) \$ 825.00
SMK 50	DECALS: Dismount at Rear, No Step, 9 or 15 Gallon 80 Octane (2 each) also No Push, 6 Gallon 80 Octane, Panel Words & Phrases and Battery Box (1 ea) .....	\$ 10.25
SMK 75	STAINLESS STEEL HARDWARE – Includes Screws, Washers, A-Point Screws, Nylon Lock Nuts & More.....	\$ 31.92
* REQUEST INFORMATION SHEET. See Page 24 for price listing OF SMK 1, 22031 & 22031 4		
<b>B.</b>	<b><u>MANUALS and PUBLICATIONS (REPRODUCTIONS)</u></b>	
(Specify Model: 415-C, 415-CD, 415-D, E, G, F-1, F-1A, A-2, A2-A, or M10)		
AD	AIRWORTHINESS DIRECTIVES and AIRCRAFT TYPE CERTIFICATE SPECIFICATIONS Includes SPECIFICATIONS for Engines/Props (All known models).....	\$ 19.50
BM	BULLETINS, LETTERS and MEMORANDUMS (All models to date).....	\$ 25.00
BM A2	ALON BULLETINS, LETTERS and MEMORANDUMS, A-2, A2-A & M10 .....	\$ 7.50
OWNER	OWNERS MANUAL for 415 Series, Forney or M10 (1969 or 1970)..... (each)	\$ 7.50
OWNER A2	OWNERS MANUAL for A-2 with A2-A supplement.....	\$ 7.50
PARTS	PARTS MANUAL Illustrated for 415 (Supplemented), Forney or M10 .....	(each) \$ 15.00
PARTS A2	PARTS MANUAL for ALON (the only one of its kind ever available) .....	(each) \$ 12.50
SERVICE A2	SERVICE MANUAL for ALON.....	\$ 12.50
415 SET	PARTS, SERVICE and AD MANUALS (set) ..... SAVE \$7.50 .....	\$ 39.50
FORNEY SET	PARTS, SERVICE and AD MANUALS (set) ..... SAVE \$7.50 .....	\$ 39.50
M10 SET	PARTS, SERVICE and AD MANUALS (set) ..... SAVE \$7.50 .....	\$ 39.50
ALON SET	PARTS, SERVICE, FLIGHT, OWNER and BM A2 MANUALS (set) SAVE \$13.50 .....	\$ 41.50
FLITE OP	FLIGHT OPERATIONS MANUAL (Specify Models; 415-C, 415-D, E, G, F-1, F-1A, or A-2)..... (each)	\$ 7.50
FORNEY INST	FORNEY INSTRUCTION MANUAL (F-1) .....	\$ 7.50
CONTOPS	CONTINENTAL ENGINE OPERATOR'S MANUAL.....	\$ 7.50
CONTOVHL	CONTINENTAL ENGINE OVERHAUL MANUAL .....	\$ 12.50
CONTSPT	CONTINENTAL ENGINE PARTS MANUAL.....	\$ 11.50
CONTSET	CONTINENTAL ENGINE OVERHAUL, OPERATOR'S and PARTS (set). SAVE \$4.50 .	\$ 27.00
EISEMANN	MAGNETO SERVICE and PARTS MANUAL .....	\$ 9.50
MARVEL	MARVEL-SCHEBLER CARBURETOR OVERHAUL and PARTS MANUAL .....	\$ 18.95
STROMBERG	CARBURETOR OVERHAUL and PARTS MANUAL .....	\$ 13.50
TIGER	TWIN TAIL TIGER (Capsule History & Tips).....	\$ 2.00
STORY	THE ERCOUCPE STORY by Collins (1946) .....	\$ 2.00
AIRTEX RE	FABRIC WING RECOVERING MANUAL (while they last) .....	\$ 8.00
MODEL	PLANS for scale model ERCOUCPE U-control or display - W -36" F-21" .....	\$ 2.00

<u>PART NUMBER</u>	<u>DESCRIPTION</u>	<u>PRICE</u>
<b>C. <u>DECALS and PLACARDS</u></b>		
BA8810D	BRACKET FILTER ASSEMBLY DECAL (Replacement).....	\$ 1.50
SMK-50	DECAL KIT: See Description on Page 1 .....	\$ 10.25
DECAL NP or NS	NO PUSH or NO STEP Decals .....	(each) \$ 1.00
DECAL DR	DISMOUNT AT REAR Decal Need 2.....	(each) \$ 1.98
DECAL MS	MASTER SWITCH GUARD for SMK-15 Baggage Compartment.....	\$ .60
DECAL WT65	BAGGAGE COMPARTMENT 65 lbs. Max 415-C, -CD, -D, E .....	\$ .60
DECAL WT75	BAGGAGE COMPARTMENT 75 lbs. Max Model G, F-1, F-1A .....	\$ .60
DECAL WP	INSTRUMENT PANEL Decal Sheet - Cut Out Words & Phrases .....	\$ 1.45
DECAL 6G,9G,15G	6 GALLON, 9 GALLON, or 15 GALLON 80 Octane (each).....	\$ .60
00011 or 00012	“ERCOUPE” Nameplate for Side Cowl RH or LH Metal.....	(each) \$ 20.29
33483	PARKING BRAKE HANDLE Decal.....(Push-Button Style).....	\$ 1.50
51007E or 51007	INCAPABLE OF SPIN Placard: SN 1-112 (51007E is \$5.82) or SN 113 & up 51007 is .....	\$ 4.62
51008	WING FUEL TANK SHUTOFF Placard (RH Tank).....	\$ 4.30
51080	IGNITION SWITCH Placard .....	\$ 3.20
51019	FUEL SHUTOFF Placard - SN 1-112 14 GALLON .....	\$ 3.25
51026	BEWARE OF PROPELLER Placard – Covers Old Compass Hole .....	\$ 9.95
51054 or 51135	NAVIGATION LIGHTS Placard SN 113-4423 (51054 is \$3.10) or 4424 & up 51135 is .....	\$ 8.10
51078	Combined Operating Characteristics Placard for 415-D/E/G.....	\$ 10.81
51142	IGNITION SWITCH - Clear Plastic SN 4424 & up.....	\$ 6.77
51143	NO SMOKING Placard.....	\$ 4.79
51144	FUEL SHUTOFF 415/F1 Header Tank.....	\$ 4.42
51148	INCAPABLE OF SPINNING Placard.....(All models) .....	\$ 9.75
54045 or 54016S	MASTER SWITCH Placard...(54045 is 415-C thru G) or (54016S is FORNEY).....	\$ 5.46
54062	BATTERY BOX Decal.....	\$ 2.75
150059-013	PARKING BRAKE Placard A-2/A2-A/M10 .....	\$ 1.48
150059-033	GENERAL INFORMATION A-2/A2-A/M10.....	\$ 1.54
150059-039	WING TANK FUEL SHUTOFF-RH A-2/A2-A/M10 .....	\$ 2.50
<b>ALL DECALS (Except 33483) are SELF ADHESIVE</b>		

**D. GENERAL MISCELLANEOUS PARTS**

ROLITE	Metal Polish and Fiberglass Cleaner (10 oz Can).....	\$ 13.25
ROLITE 2	Metal Polish and Fiberglass Cleaner (2 Pound Can) .....	\$ 26.95
MS20995C32	SAFETY WIRE .032 (1 Pound roll).....	\$ 12.25
MS20995C41	SAFETY WIRE .041 (1 Pound roll).....	\$ 10.50

**E. TOW BARS**

DH015	Spring loaded - 2 piece for Dual Fork .....	\$ 49.95
DH018	Deluxe - 2 piece for Single Fork.....	\$ 45.65
HH001	Standard - 2 piece for Dual Fork “Armstrong Model” .....	\$ 32.95
HH002	Standard - 1 piece for Single Fork.....	\$ 29.95

**We also stock a wide range of NAS, MS & AN HARDWARE and FITTINGS  
Call for PRICING AND AVAILABILITY**





**CENTER SECTION / MAIN BEAM (SPAR)**

<u>PART NUMBER</u>	<u>DESCRIPTION</u>	<u>PRICE</u>
<b>A. <u>KITS and MODIFICATIONS</u></b>		
FMK-9	WALKWAY BOX - NON SKID TREAD, ADHESIVE BACKED .....	(each) \$ 17.50
FMK-19	REAR SPAR REINFORCEMENT KIT (AD59-5-4) .....	\$ 34.52
SMK-60L	BUTT RIB GUSSET REPAIR KIT .....	\$ 45.50
SMK-60R	BUTT RIB GUSSET REPAIR KIT .....	\$ 45.50
SMK-60	BUTT RIB GUSSET REPAIR KIT Set (save \$9.00) .....	\$ 82.00

**B. PARTS and MISCELLANEOUS**

MS20004 8	BOLT SPAR ATTACH to FRAME "C" (415-C THRU F-1A) (Need 8).....	(each) \$ 9.50
NAS144-19	BOLT SPAR ATTACH to FRAME "C" (A-2/A2-A/M10) (Need 8) .....	(each) \$ 11.95
MS20002C4	WASHERS .....(To be used with above bolts) .....	\$ .30

<p align="center"><b>Come Fly With Us Ercoupe Owners Club</b></p> <p><i>Join with other owners and pilots of Ercoupe, Alon, Foinny and M-10 Cadet aircraft. The EOC was founded to provide a way for owners and pilots of Ercoupes to exchange ideas and make available information on parts, repairs and safe responsible flight. Members enjoy free classified ads in the newspaper, discounts on parts and accessories and special insurance rates.</i></p> <p><b>Mail to: Ercoupe Owners Club 7263 Schooners Ct SW A-2 Ocean Isle Beach, NC 28469-5644</b></p>	<b>Membership Application</b> <i>(Allow 4-6 weeks for delivery)</i>	
	<p><b>Annual Dues:</b> U.S. - \$25.00                      Canada/Mexico - \$25.00 (US Funds) Foreign - \$35.00 (US Funds)</p> <p align="center"><input type="checkbox"/> <b>New Member</b>    <input type="checkbox"/> <b>Renewal</b></p> <p>Name _____</p> <p>Address _____</p> <p>City _____ State _____ Zip _____ + _____</p> <p>Phone: (H) _____ (O) _____ Fax _____ E-mail: _____</p> <p>N# _____ Serial# _____ Model _____ Year Manufactured _____</p>	

ELECTRICAL / LIGHTING

<u>PART NUMBER</u>	<u>DESCRIPTION</u>	<u>PRICE</u>
<b>A. <u>KITS and MODIFICATIONS</u></b>		
FMK-16	LANDING LIGHT KIT-Dual Lamps side by side for Wing Leading Edge Metal Wings Only (See SMK-2 or SKYPORTS's SMK-101) .....	
SMK-2	LANDING LIGHT KIT for MLG Strut Leg Fairings.....	
SMK-41	RED REMINDER LIGHT. Indicates POWER ON. Mounts on Instrument Panel- Saves on the Battery. Goes on with Low Generator Output too.....	
SMK-101	WING LANDING LIGHT KIT (STC'd for Metal Wing) Single Lamp...(337) .....	
SMK-101F	WING LANDING LIGHT KIT (STC'd for Fabric Wing) Single Lamp...(337) .....	

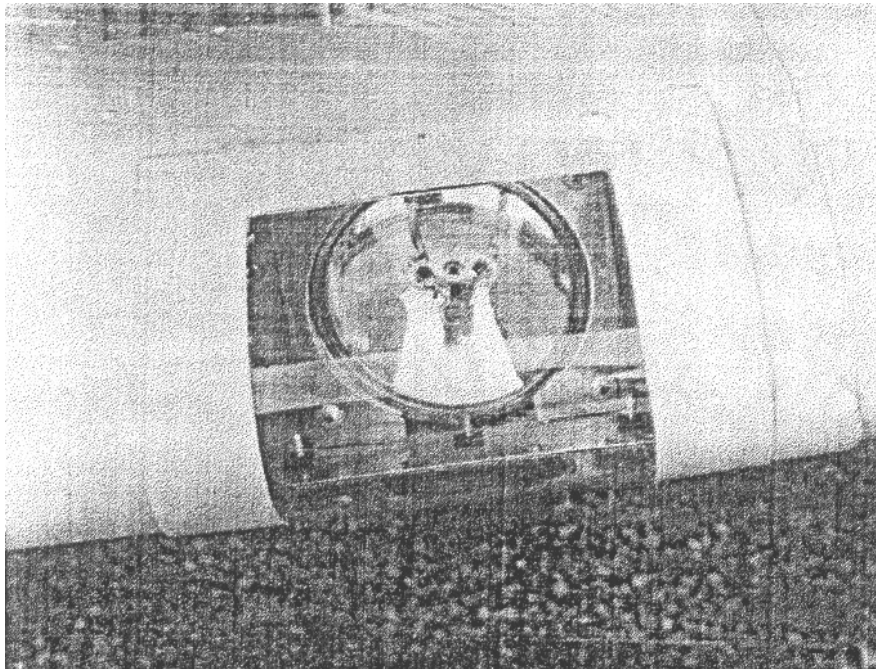

**SINGLE LAMP LANDING LIGHT  
KIT**

**SMK-101  
METAL WING  
\$249.95**

**SMK-101F  
FABRIC WING  
\$254.95**

**STC'd  
Order two, one for each wing.  
Take 10% off!!!**

**This KIT is eligible for installation on any MODEL 415-C through M10, RAG WING or METAL WING. It can be installed on the LEFT, RIGHT or BOTH WINGS. Request a copy of the INSTALLATION INSTRUCTIONS before starting. First time installation takes about 3 or 4 man-hours.**

<u>PART NUMBER</u>		<u>DESCRIPTION</u>	<u>PRICE</u>
<b>B. <u>PARTS: LENS NAVIGATION, LANDING and COCKPIT LIGHTING</u></b>			
A1233C		NAV LIGHT LENS – CLEAR (with gasket)..... GRIMES MODEL “C”.....	\$ 34.75
A1233R		NAV LIGHT LENS – RED (with gasket)..... GRIMES MODEL “B”.....	\$ 45.95
A1233G		NAV LIGHT LENS – GREEN (with gasket)..... GRIMES MODEL “B”.....	\$ 32.95
A1232A		NAV LIGHT GASKET ..... GRIMES MODEL “C/B”.....	\$ 1.69
A1234		BALE WIRE..... GRIMES MODEL “C/B”.....	\$ 15.00
SSA1234		BALE WIRE – STAINLESS..... GRIMES MODEL “C/B”.....	\$ 12.50
A1719	NEW	MAP LIGHT (51083 34)..... GRIMES.....	\$ 21.35
A1943	NEW	TAIL LIGHT ASSEMBLY ..... GRIMES ,MODEL; “C” .....	\$ 132.75
A1943-5		TAIL LIGHT HOUSING - BASE ONLY ..... GRIMES MODEL “C” CLEAR.....	\$ 23.65
A2430G		NAV LIGHT ASSEMBLY COMPLETE..... GREEN GRIMES MODEL “B” .....	\$ 137.88
14099	NEW	LENS - DUAL WING LANDING LIGHT .....	\$ 47.17
210346-005	NEW	FAIRING WING NAV LIGHT-FLARED to WING.. GRIMES MODEL “E” .....	\$ 35.71
210353-001	NEW	LENS - SINGLE M10 WING LANDING LIGHT .....	\$ 41.35
31160-17	NEW	JUNCTION BOX NAV LIGHT SYSTEM .....	\$ 11.95
470011-013		LENS – For ALON STYLE TAIL CONE.....	\$ 89.95

**C. STROBES****FLIGHT STROBE  
FAA-PMA**

Modern technology and circuitry has been applied to develop the Flight-Strobe to a point of unmatched reliability, visibility and longevity. This precision compact unit mounts EASILY on top or below fuselage, and directly replaces rotating beacons. Visible, over 50 miles at night, in haze, smog or bright sunlight. No moving parts or motor to fail. Rugged, impact resistant, with much longer lamp life and is easy to install. Made with highest quality components. Made in the U.S.A. Form 337 required FOR ERCOUPE INSTALLATION. Sample provided. **Extended warranty of 2 years or 500 hours.**

FS4400-12V		FLIGHT STROBE (intended for belly mount) 850 effective candle power – 12 volt-3 amp, with CLEAR LENS. Available with RED LENS or combined RED-CLEAR LENS. (Add \$10.00) ..	\$ 145.50
FS205	NEW	MOUNTING RING ADAPTER – Stiffens hole cut in fuselage .....	\$ 24.59
FS227		REPLACEMENT LAMP – Directly replaces short life rotating beacons 3 ¾ in diameter. ..	\$ 35.20
FS210		REPLACEMENT LENS – Clear.....	\$ 26.95
FS210R		REPLACEMENT LENS – Red.....	\$ 33.30
FS210C12R		REPLACEMENT LENS – Red/Clear .....	\$ 29.95

*Zinc plated, no rust hardware, no shock hazard and weighs only 1lb. 4 oz*

***AVAILABLE NOW***

***REBUILT (FAA-PMA APPROVED)  
YELLOW TAG***

GENERATORS

STARTERS

STARTER DRIVES

MAGNETOS

***NEW***

VOLTAGE REGULATORS

SLICK MAGNETO KITS

IGNITION HARNESS

SEE PAGES 8 THROUGH 11  
SECTION 4 FOR CURRENT PRICING

<u>PART NUMBER</u>		<u>DESCRIPTION</u>	<u>PRICE</u>
<b>D. <u>MISCELLANEOUS ELECTRICAL SYSTEM PARTS</u></b>			
AN3022-2	NEW	SWITCH PANEL LIGHT (51083-39) .....	\$ 24.20
AN3023-2		MASTER SWITCH (53071-4).....	\$ 52.50
AN3160-5	NEW	SWITCH 5 AMP TOGGLE CIRCUIT BREAKER (51054).....	\$ 30.86
A510-5		MAGNETO IGNITION SWITCH KEYED (51029).....(Requires 337).....	\$ 82.35
GE1816		LAMP MINI - (SMK 41, SMK 49WL) .....	\$ 1.11
GE93		LAMP SINGLE CONTACT .....	\$ 1.30
GE94		LAMP DOUBLE CONTACT .....	\$ 1.82
GE4509		LAMP LANDING/TAXI LIGHT (AVERAGE LIFE: 25 HOURS) .....	\$ 16.95
GEQ4509	NEW	LAMP LANDING/TAXI LIGHT HALOGEN (AVERAGE LIFE: 100 HOURS) .....	\$ 37.75
MF3A	NEW	BENDIX MAGNETO NOISE SUPPRESSOR.....(WHILE THEY LAST).....	\$ 12.50
W31X2M1G10		SWITCH CIRCUIT BREAKER - 10 AMP TOGGLE SWITCH .....	\$ 28.75
51080		PLACARD - METAL MAG SWITCH .....	\$ 2.90
51142		PLACARD - CLEAR PLASTIC MAG SWITCH (SN 4424 and up).....	\$ 6.17
VR300-14-20		VOLTAGE REGULATOR – 20 AMP .....	\$ 125.50
VR300-14-25		VOLTAGE REGULATOR – 25 AMP .....	\$ 135.50
VR300-14-35		VOLTAGE REGULATOR – 35 AMP .....	\$ 145.50

***See page 10 for Rebuilt Starter and Generator Prices!!!***  
***See page 11 for available Electrical System Instruments***

**ENGINE / ENGINE ACCESSORIES / PROPELLER**

<u>PART NUMBER</u>	<u>DESCRIPTION</u>	<u>PRICE</u>
<b>A. <u>KITS and MODIFICATIONS</u></b>		
FMK 3	MCCAULEY PROP BOLTS and WASHERS for FLANGE CRANKSHAFT .....	\$ 24.95
FMK 3A	MCCAULEY PROP BOLTS, NUTS and WASHERS for TAPER CRANK.....	\$ 25.95
SMK 3*	ENGINE CONVERSION (75 HP - 85 HP) BAFFLES .....	\$ 587.50
SMK 28**	SHIELDED IGNITION HARNESS EISEMANN LA4 MAGNETO.....	\$ 217.95
SMK 29**	HARNESS for BENDIX-SCINTILLA MAGNETOS – S4-20 Series.....	\$ 205.10
SMK 29S**	HARNESS for SLICK MAGNETO 4201 – 4000 Series .....	\$ 205.10
SMK 30	STROMBERG NAS3A1 CARBURETOR REBUILD GASKET KIT (Includes MANIFOLD and AIR INTAKE GASKETS) .....	\$ 43.50
SMK 55	ENGINE BOLT and NUT KIT - ENGINE to MOUNT ..... (C75/85/90)..... Does not include engine mount washers – 21430. Page 11.	\$ 32.95
SMK 55A	BOLT and NUT KIT - MOUNT to FIREWALL 415 SERIES (C75/89/90) .....	\$ 9.95
SMK 55B	BOLT and NUT KIT - MOUNT to FIREWALL F1/A2/M10.....	\$ 12.95
SMK 55G	BOLT and NUT KIT - MOUNT to NOSE GEAR .....	\$ 7.49
SMK 57	MARVEL - SCHEBLER CARBURETOR GASKET KIT (16-696) .....	\$ 45.13
SMK 86	STARTER BUSHING/SEAL/BRUSH KIT .....	\$ 89.95

**O-200 ENGINE CONVERSION**

SMK49*	MODEL 415-D O-200 ENGINE INSTALLATION (STC) Needs 337 .....	\$ 129.00
(Other Models By 337 Approval –(E, G, F-1, A-2 – SAMPLES AVAILABLE)		

**THE following KITS are available from SKYPORT to complete your CONVERSION to the O-200**

SMK 49BW	ENGINE MOUNT to ENGINE HARDWARE KIT for O-200.....	\$ 65.83
SMK 49D	SPECIAL SMK-49 O-200 DECAL SHEET (Included with basic kit SMK-49).....	\$ 3.10
SMK 49FP***	ELECTRIC FUEL TRANSFER PUMP for O-200 (FAA-PMA) .....	\$ 112.95
SMK 49H	HOBBS PRESSURE SWITCH for O-200 .....	\$ 62.25
SMK 49LM	CONTINENTAL ENGINE MOUNTS – FULL SET for O-200 .....	\$ 295.89
SMK 49WL	FUEL PUMP WARNING LIGHT with CIRCUIT BREAKER SWITCH for O-200.....	\$ 55.75

\* **REQUEST INFORMATION SHEET**\*\* **SPECIFY ENGINE MODEL C75/85/90 or O-200**\*\*\***GASKETS and FILTERS AVAILABLE. See Page 13, Section 5B**

<u>PART NUMBER</u>	<u>DESCRIPTION</u>	<u>PRICE</u>
<b>B. MISCELLANEOUS INDUCTION SYSTEM PARTS</b>		
BA-8810*	ROUND AIR FILTER ASSEMBLY (Includes one filter) ..... <b>STC-FAA-PMA</b> .....	\$ 27.95
BA-8810-00	Replacement Screen for BA-8810.....	\$ 10.50
BA-8810D	REPLACEMENT DECAL for BA8810.....	\$ 1.50
BA-8810H	REPLACEMENT HARDWARE KIT for BA8810.....	\$ 2.50
BA-8805*	REPLACEMENT ROUND FILTER ELEMENT ..... <b>STC-FAA-PMA</b> .....	\$ 6.40
BA-4106* (AD 96-09-06)	SQUARE AIR FILTER ASSEMBLY (Includes one filter) ..... <b>STC-FAA-PMA</b> .....	\$ 35.50
BA-4108*	REPLACEMENT SQUARE FILTER ELEMENT..... <b>STC-FAA-PMA</b> .....	\$ 5.85

**\*BRACKETT CARBURETOR AIR FILTER:** The BRACKETT FILTER is available in ROUND FORM to fit EARLIER C-75 or C-85 equipped aircraft. After initial purchase of the ASSEMBLY, future servicing involves only REPLACEMENT of DISPOSABLE PRE-WETTED BA8805 FILTER ELEMENT. We also stock BA4106 SQUARE FILTER assemblies for later MODEL C-90 and 0200 ENGINES. Installation is STC'D and all items come with full FAA-PMA APPROVAL.

21051	CARBURETOR TO MANIFOLD GASKET.....	\$ 1.34
21185	INTAKE PIPE HOSE - INNER (NEED 8) .....(each)	\$ 1.00
21323	GASKET AIR INTAKE TO CARBURETOR.....	\$ 1.29
22250	INTAKE ELBOW GASKET (NEED 4).....(each)	\$ 1.49
22800	INTAKE PIPE HOSE - OUTER (NEED 8) .....(each)	\$ 1.67
2523047**	CARBURETOR NEEDLE (DELTRIN)..... STROMBERG.....	\$ 96.50
EL4347**	CARBURETOR WEIGHT FOR DELTRIN NEEDLE ..... STROMBERG.....	\$ 18.64

**\*\* REFER to SERVICE BULLETIN ACSB - 84 Before Installation. ASK FOR COPY.**

AN737TW74	INTAKE HOSE CLAMP - (NEED 16)..... (each)	\$ 3.75
383911	CARB SEAT - (STANDARD) STROMBERG, PRE-MATCHED for DELTRIN NEEDLE .	\$ 89.38
40585 1	AIR FILTER AIR MAZE - ROUND ORIGINAL. 415/F1 .....	\$ 74.25
51138	THROTTLE CABLE (S/N 4424 and up)..... QUADRANT TYPE.....	\$ 251.35
51139	THROTTLE ROD (S/N 4424 and up)..... FOR USE WITH 51138 .....	\$ 27.99
BL0480	THROTTLE CABLE - FRICTION LOCK..... S/N 113 - 4424.....	\$ 74.95
SCAT 6 ***	AERODUCT 1 1/2" DIAMETER ..... (sold by the foot) .....	\$ 5.44
SCAT 6A***	AERODUCT 1 5/8" DIAMETER ..... (sold by the foot) CABIN HEAT .....	\$ 6.42
SCAT 7***	AERODUCT 1 3/4" DIAMETER ..... (sold by the foot) .....	\$ 5.85
SCAT 8***	AERODUCT 2" DIAMETER ..... (sold by the foot) CARB HEAT .....	\$ 7.85

**\*\*\* SCAT AERODUCT. Other sizes available. CALL for PRICE QUOTE.**

**REBUILT or OVERHAULED FACTORY YELLOW TAG MARVEL SCHEBLER CARBURETORS AVAILABLE. CALL for PRICING and AVAILABILITY. MA3-SPA all models for C75/85, C90 and O200 ENGINES (10-4240-1, 10-4252 and 10-4894-1). Some models require a matching Part Numbered CORE before a replacement can be shipped.**

<u>PART NUMBER</u>	<u>DESCRIPTION</u>	<u>PRICE</u>
--------------------	--------------------	--------------

**C. MISCELLANEOUS CRANKCASE and ACCESSORY PARTS**

1101876REB	*GENERATOR REBUILT 12 AMP (Add \$125.00 core)**	\$ 225.50
1101879REB	*GENERATOR REBUILT 25 AMP (Add \$150.00 core)**	\$ 247.50
1101890REB	*GENERATOR REBUILT 20 AMP (Add \$150.00 core)**	\$ 247.50
1101898REB	*GENERATOR REBUILT 35 AMP (Add \$200.00 core)**	\$ 260.50
1109656REB	*STARTER REBUILT.....(Add \$175.00 core)**	\$ 245.00
1971890REB	*STARTER DRIVE REBUILT.....(Add \$120.00 core)**	\$ 235.00

\* **REBUILT GENERATORS, STARTERS and STARTER DRIVES are FAA-PMA with YELLOW TAG.**

\*\***FULL CORE REFUNDS SUBJECT to a REBUILD ABILITY EVALUATION by REPAIR STATION.**

22344	OIL COOLER GASKET .....	\$ 1.46
22350	OIL SCREEN HOUSING GASKET .....	\$ 7.13
24321	CRANKSHAFT SEAL TAPER SHAFT.....	\$ 37.95
35019	GENERATOR AND TACHOMETER DRIVE GASKET.....	\$ 3.78
352179	STARTER PAD GASKET .....	\$ 3.38
530019	CRANKSHAFT SEAL FLANGED SHAFT .....	\$ 29.95
530642	FUEL PUMP GASKET.....	\$ 1.72
530928	PUSHROD HOUSING GASKET (NEED 4).....(each)	\$ 2.08
539840	PUSHROD RUBBER CONNECTOR (NEED 8).....(each)	\$ 1.20
5484	CRANKCASE COVER GASKET.....	\$ 5.75
626983	NEW VACUUM PUMP PAD MOUNT GASKET.....	\$ 1.67
632085	TACHOMETER DRIVE HOUSING GASKET.....	\$ 2.04
632050	GENERATOR DRIVE COUPLING BUSHING (NEED 2).....(each)	\$ 3.38
642714	TACHOMETER DRIVE SEAL (21163) .....	\$ 4.48
653982	GENERATOR DRIVE COUPLING RETAINER .....	\$ 14.95
A1170	PROPELLER BUSHING - TAPERED CRANK .....	\$ 4.66
MS35769-11	OIL TEMPERATURE PROBE GASKET (AN900-10).....	\$ .72
MS35769-18	OIL PRESSURE HOUSING GASKET (AN900-14).....	\$ .72
MS35769-48	OIL SCREEN GASKET (AN900-28).....	\$ 1.00
MS39326-20	NEW PUSHROD CONNECTORS SNAP RINGS CLAMPS (536388).....	\$ 1.44
MS9134-01	NEW VACUUM PUMP COVER GASKET.....	\$ .44

**D. MISCELLANEOUS CYLINDER and EXHAUST PARTS**

21477	CYLINDER BASE SEAL (NEED 4).....(each)	\$ .62
22022	EXHAUST NUT BRASS (NEED 8).....(each)	\$ .76
40167	EXHAUST/MUFFLER CLAMP with HARDWARE.....	\$ 47.88
402151	EXHAUST FLANGE STUD (STANDARD SIZE).....	\$ 3.69
402151 P03	EXHAUST FLANGE STUD - OVERSIZE .....	\$ 3.56
402151 P07	EXHAUST FLANGE STUD - OVERSIZE .....	\$ 5.48
40401 S	EXHAUST STACK LEFT 415 / FORNEY (STAINLESS).....	\$ 512.50
40402 S	EXHAUST STACK RIGHT 415 / FORNEY (STAINLESS) .....	\$ 512.50
40511REB	MUFFLER, ORIGINAL STYLE (YELLOW TAG REBUILT)(Add \$50.00 CORE).....	\$ 325.95
40511 1	MUFFLER - 415 / FORNEY...(ERCOUPE SERVICE. BULLETIN 30) .....	\$ 495.50
40515	HEAT MUFF SHROUD CABIN HEATER.....	\$ 133.69
40520	HEAT MUFF SHROUD CARBURETOR HEAT .....	\$ 184.75
655706	NEW ROCKER BOX GASKET (OLD NUMBER-530162) (NEED 4).....(each)	\$ 3.96
530162S	ROCKER BOX GASKET SILICONE (NEED 4).....(each)	\$ 7.50
627429	EXHAUST GASKET - SPIRAL WOUND / BLO-PRUF.....	\$ 6.60



632837

EXHAUST GASKET - 24185 (NEED 8, used in pairs) .....(each) \$ 1.73

<u>PART NUMBER</u>	<u>DESCRIPTION</u>	<u>PRICE</u>
<b>E.</b>	<b><u>MISCELLANEOUS OIL SUMP PARTS</u></b>	<b>OS (OVERSIZE SHIPMENT)</b>
3577	OIL SUMP GASKET .....	\$ 2.82
533355	OIL CAP GASKET .....	\$ 2.04
MS35769-11	OIL DRAIN GASKET (AN900-10).....	\$ .72
TAF	OIL FILTER ADAPTER KIT - STC'D WITH FILTER.....	\$ 229.00
CH48108	OIL FILTER for ABOVE TAF KIT .....	\$ 18.50
S6250	OIL DRAIN VALVE .....	\$ 81.50
S6250K	OIL DRAIN VALVE - O RING KIT .....	\$ 15.50

**F. MISCELLANEOUS MAGNETO PARTS**

K4520	SLICK MAGNETO/HARNESS CONVERSION KIT..... (Call for CURRENT PRICES)	
534750	MAGNETO GASKET SLICK (ROUND BASE) (649954).....	\$ .75
649986	MAGNETO GASKET (Need 2) ..... OLD PN: 535324 .....	(each) \$ 3.83
LA4	REBUILT EISEMANN MAGNETO LA4 – YELLOW TAG (Add \$50.00 Core).....	\$ 375.00
REM40E	CHAMPION SPARK PLUGS.....	\$ 19.95

**WE ALSO STOCK some EISEMANN and SLICK PARTS**

**G. MISCELLANEOUS ENGINE MOUNT PARTS**

21530	ENGINE MOUNT WASHER (C75, 85, 90) .....	(Need 4) .....(each) \$ 7.32
22387	ENGINE MOUNT RUBBER BUSHINGS (C75, 85, 90).....	(Need 8) .....(each) \$ 1.62
31920	ENGINE MOUNT.....	FACTORY .....
530740	ENGINE MOUNT RUBBER BUSHINGS – 0200 .....	(Need 8) .....(each) \$ 14.14

**H. MISCELLANEOUS MONITORING INSTRUMENTS**

**2-1/4" DIAMETER**

82319	FUEL PRESSURE GAUGE. (STC-FAA-PMA for 30 GAL KITS) .....	\$ 64.95
D1 111 5066*	OIL PRESSURE GAUGE - MECHANICAL - MITCHELL** with range marks..100 PSI .	\$ 69.95
D1 111 5094*	OIL TEMPERATURE GAUGE - MITCHELL.250° .....	\$ 62.50
D1 112 5023	TACHOMETER - MITCHELL (RECORDING) FAA-TSO .....	0-3500 RPM ..... \$ 199.50
D1 211 5057*	OIL PRESSURE GAUGE - ELECTRICAL with SENDER .....	100 PSI ..... \$ 88.95
D1 211 5106	AMP METER - MITCHELL - 0 to 60 AMPS (PMA-FAA) .....	\$ 46.95
D1 211 5104*	AMP METER - MITCHELL - 0 to 30 AMPS.....	\$ 61.50
D1 312 5036*	CLOCK ELECTRIC MITCHELL.....	\$ 74.95
D1 211 5056	NEW OIL PRESSURE GAUGE-ELECTRIC 100 PSI (Without SENDER) (FAA-PMA).....	\$ 49.95
D1 211 5086	NEW VOLTMETER 8-16 VOLTS.....	\$ 49.50
PS 211 9040	PRESSURE SENDER - MITCHELL for 5056 or 5057 instruments).....	\$ 41.50
PS 211 8008	WIRE KIT for 5056 or 5057 instruments using 9040 SENDER.....	\$ 11.75

**SPECIAL FEATURES AVAILABLE**

**RANGE (RADIAL) MARKS:** Taped lines included with price. Silk Screened lines add \$20.00 to price.

**LIGHTED DIALS:** Available for an additional charge of \$60.00.

**PRE-SET TACH READING:** An extra \$10.00 will let you pick up where you left off.

**LIGHT TRAYS** – if needed: (PE 115 4076) are available for \$20.00 each.

\* **INSTRUMENTS NOT FAA PMA or TSO'd REQUIRE ONE-TIME (337 FORM) FIELD APPROVAL.**

**\*\* AN910-1D-COUPLER & AN816-4D FITTING MAY BE NEEDED TO HOOK UP TO OIL PRESS LINES.**

PART NUMBERDESCRIPTIONPRICE**FUEL / OIL SYSTEMS****A. KITS and MODIFICATIONS****OS (OVERSIZE SHIPMENT)**

FMK 28 OIL BREATHER MODIFICATION.....\$ 67.20

**RAIN PRUF FUEL GAUGES in the FILLER CAP**

FMK 51 \* COWL TANK GAUGE ASSEMBLY (AV-GAS USE ONLY)..... (each) \$ 47.85  
 FMK 51W \* WING TANK GAUGE ASSEMBLY (AV-GAS USE ONLY) ..... (each) \$ 47.85  
 FMK 51G \* COWL TANK GAUGE ASSY (AUTO or AV-GAS USERS) ..... (each) \$ 54.95  
 FMK 51GW\* WING TANK GAUGE ASSY (AUTO or AV-GAS USERS) ..... (each) \$ 54.95

**REPLACEMENT PARTS for above FMK 51 (series) FUEL GAUGE ASSEMBLIES ONLY**

SS11810w/AvGas gasket\* VENTED CAP for COWL or WING with AvGas GASKET..... (each) \$ 29.15  
 SS11810w/AutoGas gasket\*VENTED CAP for COWL or WING with AutoGas GASKET ..... (each) \$ 31.80  
 SS11820 or SS11920 FLOAT with STEM for COWL or WING TANK GAUGE..... (each) \$ 19.85  
 SS11830 or SS11930 LEXAN TUBE COWL or WING TANK with SEAL (AV-GAS) ..... (each) \$ 14.95  
 SS12030 or SS12130 GLASS TUBE COWL or WING TANK with SEAL (AUTO or AV-GAS) ..... (each) \$ 17.95

\* Specify fuel tank capacity: 5, 6, 8 or 9 gallons.

**\* FUEL PUMP REPAIR AND SERVICE KITS (FAA-PMA)****(INDIVIDUAL FUEL PUMP PARTS ARE ALSO AVAILABLE)**

~~SMK 9D FUEL PUMP DIAPHRAGM REPAIR KIT AC9051, 9867, 6861 ..... (no longer available) \$ 95.50~~  
~~SMK 9D6 FUEL PUMP DIAPHRAGM REPAIR KIT AC9076, 4036 ..... (no longer available) \$ 95.50~~  
~~SMK 9C FUEL PUMP COMPLETE REPAIR KIT AC9051, 9867, 6861 ..... (no longer available) \$ 148.95~~  
~~SMK 9C6 FUEL PUMP COMPLETE REPAIR KIT AC9076, 4036 ..... (no longer available) \$ 148.95~~  
 SMK 9K FUEL PUMP GASKET. SCREEN KIT (AD81-07-06) ..... \$ 88.66

**\* REBUILT FUEL PUMPS - FAA-PMA YELLOW TAGGED**

AC9051/9867\*\* C85-12 or C85-12F.....TCM 40585 ..... \$ 324.75  
 AC9076/4036\*\* C75 or C90-12/12F.....TCM 40695 ..... \$ 324.75  
 AC6861\*\* C90-16F or O-200.....TCM 631391..... \$ 342.00

AF40585\*\* C85-12 or C85-12F.....FACTORY NEW FAA-PMA ..... \$ 431.00  
 AF40695\*\* C75 or C90-12/12F.....FACTORY NEW FAA-PMA..... \$ 431.00  
 AF631391\*\* C90-16F or O-200.....FACTORY NEW FAA-PMA ..... \$ 450.00

\* When ordering REPAIR KITS, NEW or REBUILT pumps, SPECIFY TYPE of PUMP by Part Number that is stamped on edge of mounting flange.

**\*\* ADD \$25.00 REFUNDABLE CORE DEPOSIT****OTHER FUEL and OIL SYSTEMS KITS**

SMK 51 HOSES FOR ENGINE (3 FUEL HOSES AND OIL PRESSURE HOSE) ..... \$ 52.00  
 SMK 68, 69, 70, 71 30 GAL FUEL SYSTEM (SN: 813 & UP) (STC-FAA-PMA)(see pg 14 & 15)..... (OS) \$ 2,695.00  
 SMK 68S, 69S 30 GAL FUEL SYSTEM (SN: 1-812) NEEDS 337-NO STC)(see pg 14 & 15) ..... (OS) \$ 2,895.00  
 SMK 76 GASCOLATOR AD KIT - COMPLETE - C75/85/90 with FITTINGS ..... \$ 95.09  
 SMK 76A GASCOLATOR KIT - SUPPORT TUBES ONLY - C75/85/90..... \$ 67.79  
 SMK 76B GASCOLATOR KIT - COMPLETE - C90 with 5QT SUMP..... \$ 92.48  
 SMK 76C GASCOLATOR KIT - SUPPORT TUBES ONLY-C90/5QT ..... \$ 72.95  
 SMK 96 GASCOLATOR - METAL BOWL (STC-FAA-PMA) ..... \$ 99.95

SMK 11      NEW      WING FUEL TANK STRAINER ASSY. (With QUICK DRAIN and all FITTINGS) ..... \$ 97.95

<u>PART NUMBER</u>	<u>DESCRIPTION</u>	<u>PRICE</u>
<b>B.</b>	<b><u>PARTS and MISCELLANEOUS</u></b>	
AF 2245 1	SCREEN FUEL PUMP (643913)(AD 81-07-06) No longer available – order SMK 9K above....	
AF 766	GASKET BOLT HEAD FUEL PUMP...(643914)..... (AD 81-07-06) .....	\$ 1.50
AF 6160	GASKET CORK, FUEL PUMP COVER (643915)..... (AD 81-07-06) .....	\$ 7.80
SMK 9K1	FUEL PUMP INSPECTION KIT (Includes AF 766 and AF 6160).....	\$ 7.95
CCA 1550	CURTIS QUICK DRAIN 1/8" PIPE FAA-PMA GASCOLATOR.....	\$ 14.50
CCA 1600	CURTIS QUICK DRAIN 1/4" PIPE .....	\$ 16.95

<b>REPLACEMENT PARTS for FAA-PMA SMK-96 GASCOLATOR</b>		
SS13101	GASCOLATOR CAP ASSEMBLY .....	\$ 19.95
SS13102	GASCOLATOR BALE WIRE .....	\$ 24.85
SS13103	GASCOLATOR METAL SCREEN .....	\$ 2.90
SS13104	2 1/8" GASKET GASCOLATOR.....(METAL BOWL Type).....	\$ 1.60
SS13105	GASCOLATOR METAL BOWL ONLY - 2 1/8" .....	\$ 16.55

SS13101	GASCOLATOR CAP ASSEMBLY .....	\$ 19.95
SS13102	GASCOLATOR BALE WIRE .....	\$ 24.85
SS13103	GASCOLATOR METAL SCREEN .....	\$ 2.90
SS13104	2 1/8" GASKET GASCOLATOR.....(METAL BOWL Type).....	\$ 1.60
SS13105	GASCOLATOR METAL BOWL ONLY - 2 1/8" .....	\$ 16.55

L6	2" GASKET for GASCOLATOR.(Normally a Glass Bowl type).....	\$ 3.58
L7	2 1/4" GASKET for GASCOLATOR.(Normally a Glass Bowl type).....	\$ 3.98

31230 53 (31001 46)	FUEL SHUT-OFF VALVE - RH side from TEE.....	\$ 19.49
40430	COWL GAS TANK GROMMET .....	\$ 10.95
48073B*	VENTED WING TANK GAS CAP with AV-GAS GASKET .....	\$ 25.95
48073V*	VENTED WING TANK GAS CAP with AUTO FUEL GASKET .....	\$ 28.95
48081 1	STRAINER - FUEL SYSTEM - 2 1/2" COWL or WING TANKS .....	\$ 17.95
48201 40	RESTRICTOR FITTING - FUEL PUMP 45° ELBOW .....	\$ 34.50
48186F	FLOAT ONLY for FUEL CAP FUEL GAUGES, EPOXY COATED .....	\$ 1.10
479729**	FILTER - ELECT FUEL PUMP .....	\$ 2.51
479136**	GASKET - ELECT FUEL PUMP .....	\$ 1.24
SS10290	VENTED 15 GAL WING TANK CAP AV-GAS GASKET (FAA-PMA).....	\$ 26.50
SS10290V	VENTED 15 GAL WING TANK CAP AUTO or AV-GAS GASKET (FAA-PMA) .....	\$ 28.95
SS10290-1*	UNVENTED WING TANK CAP WITH AV-GAS GASKET (FAA-PMA).....	\$ 23.95
SS10290-1V*	UNVENTED WING TANK CAP WITH AUTO or AV-GAS GASKET (FAA-PMA).....	\$ 26.95
SS10292	GASKET LH TANK INSIDE GAUGE AV-GAS (FAA-PMA) .....	\$ 1.10
SS10292V	GASKET LH TANK INSIDE GAUGE AUTO-GAS or AV (FAA-PMA).....	\$ 2.95
SS10293	FUEL CAP GASKET AV-GAS BUNA-N-RUBBER (FAA-PMA).....	\$ 1.00
SS10293V	FUEL CAP GASKET AUTO or AV-GAS VITON RUBBER (FAA-PMA).....	\$ 3.50

**\*SPECIFY 8 or 9-GALLON WING FUEL TANK**

**NOTE: Auto gas gaskets (VITON) will work fine with Aviation Fuels also**

**\*\* REPLACEMENT ITEMS for STC-FAA-PMA ELECTRIC FUEL PUMP  
(SMK-49FP, page 8 & SMK 68 thru 71; 30 GALLON FUEL SYSTEM page 14)**

**30-GALLON FUEL SYSTEM**

**30-GALLON FUEL SYSTEM GENERAL INFORMATION  
STC FOR ALL 415, FORNEY, ALON AND M10 COUPES  
S/N 813 & ABOVE\* STC-FAA-PMA**

**KITS: SMK-68, SMK-69, SMK-70 or SMK-71**

*When you order the 30-gallon fuel system from Skyport Services, you will receive all necessary instructions for removal and installation. We have had the systems in many of our Couper's planes for over ten years with thousands of hours of flight time. We have over 40 installations with excellent results. We estimate it will take the first timer approximately 50 to 60 hours or six (6) days to complete installation. The first two days are for removal of old system. Third through fifth days are for mounting new system, with the final day for finishing installation and testing.*

*You will receive all the necessary fuel lines, fittings, clamps and brackets. A new electric standby fuel pump\*\*, and a new fuel shut off valve is included. We have made every effort during prototyping to make a "standard" system, however it is recognized that over the years no two Coupes are alike. Therefore, credit will be allowed for any un-used new parts that do not "fit" into your system or where you found duplication with old parts as specified by the instructions and /or drawings. Skyport Services will also allow a core credit for your three old tanks. Credit will be based on the condition of your old tank, with a minimum of \$25.00 each for unusable tanks and up to \$100.00 for a good condition header tank, and up to \$125.00 each for a good wing tank. Turnplate, patched tanks or poorly sealed tanks will receive minimum credit each.*

*If you have a Stromberg NAS3A1 carburetor, you will have to change the 383911 standard seat with a 384585 seat that has a .113 hole, because the new system operates at a greater fuel pressure. The 384585 seat is available from SKYPORT. No changes are necessary if you have a MARVEL-SCHEBLER MA-3SPA. If you have converted to an O-200 engine, the engine must have an engine driven fuel pump. All other Ercoupes have engine driven fuel pumps. If you have the original LH Wing Tank Fuel gauge assembly, reuse that. This original fuel gauge is no longer available through normal supply sources. Conversion to other fuel gauges offered on the open market will require field approval via form 337.*

*We feel this installation deserves serious consideration because it will eliminate the safety hazards caused by the header tank. It will give you extra fuel capacity and much needed room behind the panel. There is no effect on automotive fuel STC. Unusable fuel is less than 5%.*

\* See page 15 for more information.

\*\* See page 13 for replacement filters & gaskets for this fuel pump.

**OS (OVERSIZE SHIPMENT)**

**30-GALLON FUEL SYSTEM**

STC  
FAA - F-1A

REMOVE COWL TANK FOREVER  
HAVE MORE ROOM BEHIND PANEL  
INSTALL TWO 15 GALLON TANKS ON WING  
PRICE COMPLETE \$2695 (SN 813 & UP)  
For Models: C, CD, D, E, G, F-1, F-1A, A-2, A-2A AND M10

**ORDER:**

*SMK-68	415 with STROMBERG CARB
*SMK-69	415/F-1 with MARVEL CARB
*SMK-70	ALON-A-2 / A2-A
*SMK-71	Mooney M10

Before deciding:  
Request a sample copy of the installation instructions

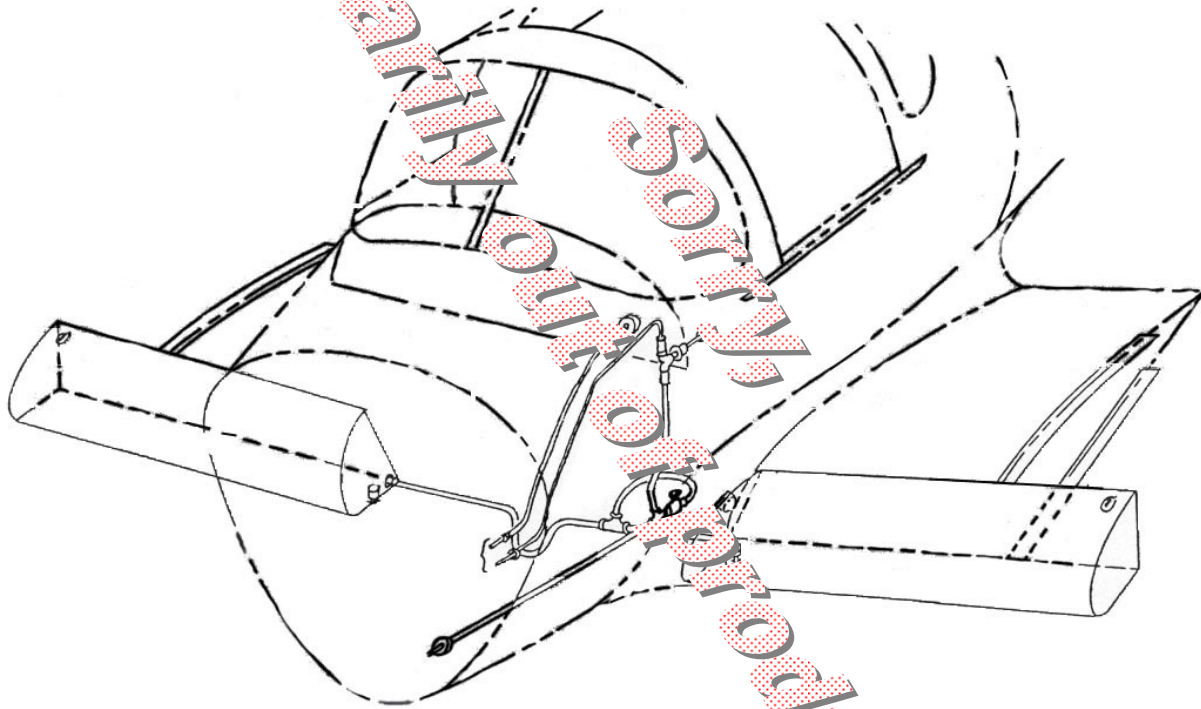

ORDERS PROCESSED AS RECEIVED. ALLOW MINIMUM OF 6 WEEKS FOR COMPLETE SHIPMENT. With a minimum 30% down payment, your order can be sent in TWO PARTS. The FIRST PART can be shipped within 7 days and would include all required parts, instructions and drawings except the fuel tanks and filler caps. These will be sent when available as PART TWO. (OS)

WHEN ORDERING PLEASE PROVIDE: The type of carburetor you'll be operating with. Also we'll need the complete aircraft identification, i.e., MODEL, SERIAL NUMBER and "N" REGISTRATION.

\*\$2895 for SERIAL NUMBERS 1-812 originally equipped with "HAYES" Main Landing Gear. These tubular steel gear legs are mounted on the front of the spar. No STC exists, but they can be installed with field approval via FAA Form 337. Order SMK 68S or SMK 69S.

**OS (OVERSIZE SHIPMENT)**



**FUSELAGE / COWLING / CABIN**

(Interior - Exterior - Accessories)

<u>PART NUMBER</u>	<u>DESCRIPTION</u>	<u>PRICE</u>
<b>A.</b>	<b><u>KITS and MODIFICATIONS</u></b>	<b>OS (OVERSIZE SHIPMENT)</b>
FMK 1*	SMALL OIL ACCESS DOOR ASSEMBLY (Approx. 5" X 6").....	\$ 75.00
FMK 1A	LARGE OIL ACCESS DOOR ASSEMBLY A-2/M10 type (Approx. 9" X 10 1/2") .....	\$ 161.95
FMK 4*	COWL SPARK PLUG FAIRINGS - ASB Plastic.....	\$ 68.95
FMK 4M*	COWL SPARK PLUG FAIRINGS - Metal.....	\$ 139.50
FMK 27	FUSELAGE DRAIN KIT (Drains rain water from FUSELAGE).....	\$ 19.80
FMK 30	CABIN FRESH AIR VENT KIT (Controlled from Panel) .....	\$ 333.00

SMK 7**	COWL EDGE REPAIR KIT - Blank Aluminum strip for bottom edge repairs. Comes with CAMLOC SLOTTED STUDS installed - LH, RH or SET .....	\$ 72.65
SMK 7A**	Above KIT with <b>WING HEAD STUDS</b> installed- LH, RH or SET.....	\$ 94.45
SMK 8**	COWL EDGE REPAIR KIT with DZUS SLOTTED STUDS installed- LH, RH or SET ...	\$ 46.65
SMK 8A**	Above KIT with <b>WING HEAD STUDS</b> installed- LH, RH or SET.....	\$ 54.95
SMK 12	BAGGAGE COMPARTMENT CUSTOM CANVAS Original design .....	\$ 57.50
SMK 15***	BAGGAGE COMPARTMENT KIT LARGE 9 CUBIC FT (STC) for 415/F-1/F-1A (OS) \$	239.25
SMK 15A	BAGGAGE COMPARTMENT UPHOLSTERY to match your AIRTEX Interior .....	\$ 190.00
SMK 56	WINTERIZATION KIT - FRONT COWL (415 METAL NOSE BOWLS) .....	\$ 31.95
SMK 56A	WINTERIZATION KIT - FRONT COWL (F-1 or ALON/M10 METAL NOSE BOWLS). \$	31.95
SMK 56K	WINTERIZATION KIT - FIBERGLASS SUPER NOSE BOWL See back cover.....	\$ 49.95
SMK 72****	SUPER NOSE BOWL - without AIR VENT.....STC - 337 Required .....	(OS) \$ 240.25
SMK 73****	SUPER NOSE BOWL - with AIR VENT..... STC - 337 Required.....	(OS) \$ 264.95
SMK 77, 78, 79	INSTRUMENT PANEL KITS .....	SEE DETAILS ON PAGE 17 .....

\* *SAMPLE 337 provided.*\*\* *DEDUCT 15% if you wish to install the DZUS or CAMLOC studs yourself. DEDUCT 50% if you do not need both sides (SET) but only need one side LH or RH.*\*\*\* *INFORMATION SHEET available upon request. - (SMK 15 STC'd Requires 337).*\*\*\*\* *DEDUCT 15% if you wish to fill, sand, and prime yourself.***B. PARTS and MISCELLANEOUS**

14044	TIE DOWN RING - TAIL CONE or WINGS.....	\$ 7.50
22A27 2048	NUT PLATE, RIGHT ANGLE - For TIE DOWN RING in TAIL CONE.....	\$ 1.75
A2 100	SNAP VENT Fresh air into cockpit .....	(pair) \$ 8.51
A56	COWL CHAFE WEBBING 1/16" X 1" (ROLL 15') .....	\$ 15.30
TA8071	COWL BAFFLE SEAL - Silver Fiberglass/Neoprene impregnated 9 ft x 3" x 1/16" .....	\$ 45.50
TSR3	COWL BAFFLE SEAL - Red/Orange Silicone 9 ft x 3" x 1/8" .....	\$ 42.50

**C. CAMLOC FASTENERS for S/N 2623 or later**

4002 5	CAMLOC SLOTTED STUD .....	(RECESSED 40S5 5- \$3.88).....	\$ 2.50
4002-5S/40S5-5S	CAMLOC STUDS STAINLESS.....	(SLOTTED OR RECESSED) .....	\$ 4.80
4002 5W	CAMLOC WINGHEAD STUD.....	(STAINLESS 4002 5SW - \$9.33).....	\$ 8.18
4002N	CAMLOC GROMMET.....	(STAINLESS 4002NS \$3.75) .....	\$ 1.25
4002 R4G	CAMLOC SNAP RING FOR GROMMET .....	(STAINLESS - 40G26-1 \$2.50).....	\$ .15
214 16	CAMLOC RECEPTACLE - FIXED .....		\$ 2.75
244 16	CAMLOC RECEPTACLE - FLOATING .....		\$ 3.00

4S2R

CAMLOC REPAIR GROMMET..... \$ .37

<u>PART NUMBER</u>	<u>DESCRIPTION</u>	<u>PRICE</u>
<b>D.</b>	<b><u>DZUS FASTENERS S/N 2622 or earlier</u></b>	<b>OS (OVERSIZE SHIPMENT)</b>
AJ5-30, -35, -40, -45, or -50	DZUS SLOTTED STUDS .....	(each) \$ 3.75
AJ5-30SS, -35SS, or-40SS	DZUS STUDS (in STAINLESS.....)	(each) \$ 4.95
AJW5-30, -40, -45, or -50	WING HEAD STUDS .....	(each) \$ 5.95
GA5 312	DZUS GROMMET .....	\$ .15
GP5B	DZUS GROMMET, PLASTIC ...(Needs no TOOLS).....	\$ .30
S5A-250	DZUS SPRING LOCKING RECEPTACLE.....	\$ 2.95
SR5SS	DZUS SNAP RING and WASHER .....	\$ .42

*We also stock a wide range of AN, NAS, MS & other types of HARDWARE and FITTINGS  
Call for PRICING and AVAILABILITY*

## SMK-77, SMK-78 and SMK-79

### INSTRUMENT PANEL MODIFICATION KITS

**HAPPINESS IS** *Having all INSTRUMENTS right in front of you. Our NEW "ALON STYLE" Instrument Panel fits all Models of ERCOUPES or FORNEYS ... Provides plenty of space for a full Gyro set-up. The "BASIC SIX" Flight Instruments can be grouped on a separate STANDOFF PANEL, right where they belong ... directly in front of the pilot. The bottom edge of PANEL is 1 3/4" LOWER -(13.75" high on center line) than original to permit PANEL mounting of RADIO.*



Fabricated from .050" thick ALUMINUM (Same as original panel). **NOT AN OVER-LAY.** Furnished Blank, except for CONTROL SHAFT HOLES. Layout & Instructions provided. Kit includes FIBERGLASS GLARE SHIELD for flight group instruments and RAISED FLIGHT GROUP PANEL.

SMK-77..... (OS) \$ 185.30

**NOTE: You must have BUBBLE WINDSHIELD installed to accommodate this kit because of GLARE SHIELD HEIGHT.**  
\*Glare Shield comes sanded & primed. Deduct 15% from the Glare Shield price if you wish to do that task yourself and receive it just as it comes out of the mold.

**ALSO AVAILABLE** *Panel (Same as above, but does not include the separate FLIGHT GROUP PANEL or GLARE SHIELD). Furnished blank, except for CONTROL SHAFT HOLES.*

**BUBBLE WINDSHIELD NOT REQUIRED** *for SMK 78, oversize panel only.*

SMK-78	OVERSIZE PANEL Only.....	(OS) \$ 137.45
KE2-540-9	FLIGHT GROUP PANEL Only.....(From SMK-77) .....	\$ 41.25
KE2-540-17*	GLARE SHIELD EYEBROW Only..(From SMK-77) (Sanded & Primed)* .....	\$ 57.75
SMK-79	STANDARD SIZE PANEL (Same as ORIGINAL)	
	BLANK with SHAFT HOLES..(11.875" High on Center Line) .....	(OS) \$ 118.75

**FORM 337 and ONE-TIME FIELD APPROVAL required for all INSTRUMENT PANEL ITEMS**

**LISTED ABOVE. All PANELS come with INSTRUCTIONS and a SAMPLE 337 FORM.**

<u>PART NUMBER</u>	<u>DESCRIPTION</u>	<u>PRICE</u>
<b>E.</b>	<b><u>ORIGINAL ALUMINUM COWL and FAIRING PARTS</u></b>	<b>OS (OVERSIZE SHIPMENT)</b>
13060 L/R	ALUMINUM WING ROOT FAIRING L/R ..... (RIGHT) (OS) \$587.00...(LEFT) (OS)	\$ 492.50
31039S	TAIL CONE ASSEMBLIES - NEW OLD STOCK – While they last .....	\$ 130.00
40252	LOWER COWL BAFFLE COVER PLATE .....	\$ 67.78
40451	ALUMINUM NOSE COWL without VENT .....	(OS) \$ 553.25
40460	ALUMINUM NOSE COWL with AIR VENT HOLE .....	(OS) \$ 565.50
40040, 40079 or 40079A	ALUMINUM BOTTOM COWL ..... <b>415</b> (OS) \$509.50..... <b>F1/ALON</b> (OS)	\$ 595.50
40090 L/R	SIDE COWL SKIN ASSEMBLY - (DZUS Fasteners Installed).....	(each) (OS) \$ 514.50
40559 L/R	SIDE COWL SKIN ASSEMBLY - (CAMLOC Fasteners Installed).....	(each) (OS) \$ 495.95
40422	TOP COWL ASSEMBLY - SN 2662 or EARLIER.....	(OS) \$ 550.00
40430	TOP COWL FUEL TANK GROMMET .....	\$ 10.95
40532	TOP COWL ASSEMBLY - SN 2623 or LATER.....	(OS) \$ 547.95
40532 1	TOP COWL BLANK – No holes or hinges .....	(OS) \$ 400.00

**The following FIBERGLASS items require FIELD APPROVAL**

KE2 31039	FIBERGLASS TAILCONE - ALON STYLE (With SAMPLE 337) Facilitates installation of Tail Mounted Strobe \$ 135.50	
470011 013	LENS for KE2 31039 TAILCONE or ALON ALUMINUM TAILCONE .....	\$ 98.95
KE2 40040	FIBERGLASS BOTTOM COWL.....(With SAMPLE 337).....	(OS) \$ 114.29
40090 1 L	*BLANK ALUMINUM SIDE COWL – LEFT - No HOLES or STIFFENERS.....	(OS) \$ 76.50
40090 1 R	*BLANK ALUMINUM SIDE COWL – RIGHT - No HOLES or STIFFENERS .....	(OS) \$ 76.50
40090 1 (SET)	*BLANK ALUMINUM SIDE COWLS – (10% OFF as a Set).....	(OS) \$ 137.70
* Blank ALUMINUM SIDE COWLS are cut to shape with a beveled edge. Suitable for polish or prime and paint. Re-use your old stiffeners, formers, fasteners and hinge assembly		

**AIRTEX INTERIORS**

SKYPORT is a distributor for AIRTEX. We have sold many of these quality products. Every COUPE has turned out wonderfully. Ask for a FREE PRICE LIST CATALOG or a FABRIC SAMPLE SWATCH CATALOG.

**WHAT IS AVAILABLE**

- |                               |   |
|-------------------------------|---|
| * Upholstery w/ Seat cushion* | ** Foam Soundproofing <u>Call</u>                   |
| * Wall panels*                | ** Fiberglass Insulation <u>Call</u>                |
| * Carpet*                     | ** Certificate Holder <u>\$2.25</u>                 |
| * Instrument Panel Cowl Pad   | ** Felt Strips <u>1”-\$1.95 or 2”-\$1.30 a foot</u> |
| * Upholstery (SMK 15A) for -- | ** Firewall Cover Pad <u>\$54.00</u>                |
| --large (SMK-15) Baggage Comp | ** Small Baggage Comp. (SMK 12) <u>\$57.50</u>      |
| * Hat Shelf Pads              | ** Chaff WEBBING - A56 <u>\$15.30</u>               |
| * Custom Colored Window Welts | ** Safety Seat Belts <u>\$36.00 per person</u>      |
|                               | ** Window Welts - SMK-23 <u>\$34.75 a set</u>       |

\* Allow 6-8 Weeks Delivery for Custom Orders.

\*\* Usually in stock here at SKYPORT SERVICES or readily AVAILABLE from AIRTEX stock.

## MAIN LANDING GEAR / BRAKES

<u>PART NUMBER</u>	<u>DESCRIPTION</u>	<u>PRICE</u>
<b>A.</b>	<b><u>KITS and MODIFICATIONS</u></b>	<b>OS (OVERSIZE SHIPMENT)</b>
SMK 20*	REBUILT ORIGINAL SCOTT Model 4350 MASTER CYLINDER .(Add \$35.00 CORE)... <i><u>See description below. Also consider SMK 88** NEW Replacement Master Cylinder</u></i>	\$ 149.50
SMK 34	MAIN GEAR KNEE JOINT REBUILD – S/N: 813 and newer.....	\$ 56.00
SMK 34A	OLEO STRUT ATTACH HARDWARE – S/N: 813 and newer.....	\$ 32.95
SMK 34B	OLEO STRUT ATTACH HARDWARE – S/N: 812 and older .....	\$ 39.95
SMK 34H	MAIN GEAR KNEE JOINT REBUILD – S/N: 813 and older .....	\$ 39.95
SMK 53	MASTER BRAKE CYLINDER O-RING KIT .....	\$ 3.85
SMK 53A	MASTER BRAKE CYLINDER O-RING KIT F-1A, A-2, A2-A, M10.....	\$ 2.45
SMK 53R	MASTER BRAKE CYLINDER O RING KIT for SMK-20 rebuilt cylinders.....	\$ 4.25
SMK 54	BRAKE LININGS KIT - CLEVELAND CONVERSION SN 813 &UP .....	\$ 39.95
SMK 54C	BRAKE LININGS KIT - CLEVELAND 30-4 BRAKES A-2/A2-A/M10 .....	\$ 38.50
SMK 54H	BRAKE LININGS KIT - CLEVELAND SN 812 & LOWER.....	\$ 73.00
SMK 54S	BRAKE LININGS KIT – CLEVELAND 30-63/56A BRAKES .....	\$ 41.95
SMK 54X	BRAKE CYLINDER O-RING KIT for GOODYEAR (Both sides).....	\$ 9.99
SMK 54Y	BRAKE BLEEDER SCREWS/WASHERS – GOODYEAR (2 EACH) .....	\$ .50
SMK 58	BRAKE HOSE ASSY KIT- (MLG LEGS to WHEELS). Required for CLEVELAND Kits ...	\$ 84.50
SMK 61	RUBBER CUP OLEO SEAL. Adapts to wear when O-RING fails (STC-FAA-PMA) .....	\$ 49.95
SMK 84	MLG BUSHINGS to RAISE TAIL – Steel (With 337) .....	\$ 27.50
SMK 84S	STAINLESS MLG BUSHINGS to RAISE TAIL – Stainless Steel (With 337) .....	\$ 36.75
SMK 88**	BRAKE MASTER CYLINDER REPLACEMENT (STC-FAA-PMA) Add \$35.00 CORE... <i><u>See description below. Also consider SMK 20* REBUILT Replacement Master Cylinder</u></i>	\$ 129.95
SMK 98	BRAKE RESERVOIR REPLACEMENT (For all brake systems) (STC-FAA-PMA) .....	\$ 76.95
SMK 115	NEW BELLEVILLE SPRING CONVERSION KIT (Approved for S/N: 813 and up).....	\$ 532.50

\* This rebuilt SCOTT Master Cylinder will be ideal for those older GOODRICH Brake Systems factory installed on Serial Numbers 1-812 and also on later Ercoupes and Forneys (Serial Numbers 813 and newer) with factory installed GOODYEAR Systems.

*However, and in any case you should ensure that the wheel brake linings discs and “O”-rings are like new and the system operates efficiently save replacement of a leaking or weak Master Cylinder*

\*\* The NEW Skyport FAA-PMA replacement Master Cylinder installation will give outstanding results when coupled with a CLEVELAND Wheel Brake System installation. This is the most perfect combination you can have.

Excellent system operation can be achieved with GOODYEAR brakes installed provided that the linings & discs are near new. If this is not the case, order SMK-20 instead.

However, if you have GOODRICH Brakes, SMK-88 will not work, order SMK-20 only.

### WHEEL PANTS KITS include everything you need to install.

**See PHOTO PAGE 21 SPECIFY if you have CLEVELAND MLG WHEEL/BRAKES**

SMK-63*	WHEEL PANTS - DUAL FORK NOSE WHEEL - STC – FAA-PMA .....	(OS) \$ 825.00
SMK-64	WHEEL PANTS - SINGLE FORK NOSE WHEEL – (500X4) STC – FAA-PMA.....	(OS) \$ 825.00
SMK-65*	WHEEL PANTS - DUAL FORK NOSE WHEEL - HAYES MAIN GEAR - STC/337 .....	(OS) \$ 675.00
SMK-66	WHEEL PANTS - SINGLE FORK NOSE WHEEL - HAYES MAIN GEAR - STC/337 ....	(OS) \$ 675.00
SMK-67*	WHEEL PANTS - DUAL FORK - SPRING STEEL MLG-STC/337 .....	(OS) \$ 775.00

\* NOSE GEAR FAIRINGS designed for DUAL FORK P/N 34370-34371 series ONLY.

NOSE FAIRINGS available SEPARATELY if converting to DUAL from SINGLE FORK.

<u>PART NUMBER</u>	<u>DESCRIPTION</u>	<u>PRICE</u>
<b>B. <u>PARTS and MISCELLANEOUS COUPES SN 813 and NEWER</u></b>		
33115	STRUT SHOCK PAD RUBBER DONUT ..... (S/N113 & UP) ..... (Need 8) .....	\$ 4.97
33201 18	KNEE JOINT LOCKNUT..... (Need 2) ... (each)	\$ 4.41
33201 19	KNEE JOINT LOCK WASHER..... (Need 2) ... (each)	\$ 2.82
33206	KNEE BUSHING 415/FORNEY..... (Need 2) ... (each)	\$ 8.28
510055 002	NEW KNEE BUSHING ALON/M10 ..... (Need 4) ... (each)	\$ 4.14
33209	KNEE JOINT PIN..... (Need 2) ... (each)	\$ 235.81
33215	KNEE JOINT BAKELITE WASHER..... (Need 4) ... (each)	\$ 5.92
33224	SPACERS for 33115 ABSORBER..... (Need 14) . (each)	\$ 7.50
33239	OLEO STRUT BRONZE BUSHING ..... (Need 4) ... (each)	\$ 2.82
33246	BUMPER BLOCK ONLY ..... MLG STRUT.S/N 813 & UP ..... (Need 2) ... (each)	\$ 9.26
33247	RETAINER AND STUD FOR BLOCK MLG STRUT ..... (Need 2) ... (each)	\$ 34.87
33251	NEW BELLEVILLE SPRING Replacement shock pads OLEO STRUT..... (Need 14) . (each)	\$ 33.53
33458	BRAKE PEDAL ARM (Ercoupe Service Memorandum-32) .....	\$ 166.46
33459	BRAKE PEDALS (FITS 33458 ARM) With hardware .....	\$ 45.50
MS28775-212	OLEO CYLINDER O-RING (AN6227-17)..... (Need 2) ... (each)	\$ 0.50
SS12301	RUBBER CUP OLEO SEAL with CENTER HOLE (FAA-PMA).....	\$ 5.17

**C. MLG PARTS for COUPES SN 113-812**

33105	BUSHING KNEE JOINT.....	\$ 4.50
33109-1	BUSHING OLEO STRUT (UPPER) .....	\$ 4.50
33114	NEW SPACERS SHOCK PAD (Need 16, 2 per shock pad) .....	(each) \$ 5.95
33115	SHOCK PADS "RUBBER DONUTS" .....	\$ 4.80
33159	BUMPER OLEO STRUT to GEAR LEG .....	\$ 2.50
33175-4	BUSHING OLEO STRUT (LOWER).....	\$ 3.88
33176	LOCK NUT (Need 2 for each WHEEL) .....	\$ 10.66
33177	LOCK WASHER WHEEL BEARING / NUT .....	\$ 28.89
SS12301	RUBBER CUP SEAL..... (S/N 113 & UP FAA-PMA) .....	\$ 5.17

**D. CLEVELAND 600 X 6 WHEEL and BRAKE PARTS**

SMK-58	LONGER HOSE ASSEMBLY (KIT) - With HARDWARE. ....	\$ 84.50
33201 24	LONGER HOSE ASSEMBLY Without HARDWARE and FITTINGS.....	(each) \$ 43.55

**Other CLEVELAND BRAKE/WHEEL PARTS are available.**

**Look for the CLEVELAND Assembly Part Number on Wheel or Brake Caliper.**

**Call for PRICING and AVAILABILITY!!!**

**E. GOODYEAR PARTS - WHILE THEY LAST**

**(When available USED PARTS are sold as is.)**

9520653	500 x 5 WHEEL ASSEMBLIES .....	(USED) .....	\$ 250.00
9511276	GOODYEAR BRAKE LINING.....	(USED-\$25.00) ....	(When available-NEW) \$ 60.00
9523482	BRAKE CLIP (MAY NEED 8).....	(USED) .....	(each) \$ 25.00
955383	BRAKE CLIP FASTENER (MAY NEED 8).....	(NEW) .....	(each) \$ 2.95
952353	GOODYEAR WHEEL HUBCAP / DUST COVER .....	(NEW) .....	\$ 28.95
9530294	BRAKE DISCS - (OLD #30187) No Longer Available.....	(Call for USED Stock)	
4310	MASTER CYLINDER RETURN SPRING .....	(NEW) .....	\$ 15.55
SMK-54Y	BLEEDER SCREW and WASHER SET (2 EACH).....	(NEW) .....	\$ .50

**We carry other GOODYEAR and GOODRICH WHEEL & BRAKE PARTS**





# WHEEL FAIRINGS

*THE BEST IN THE BUSINESS*

For All COUPE'S, FORNEY'S ALON'S and M10'S



## STANDARD CAST ALUMINUM MAIN GEAR LEGS

*\*FAA - PMA - STC'd*

* SMK-63	DOUBLE NOSE FORK	\$ 825.00 (OS)
* SMK-64	SINGLE NOSE FORK	\$ 825.00 (OS)

## EARLY TUBULAR STEEL (HAYES) MAIN GEAR LEGS

*\*\*FAA - STC'd - w/337*

** SMK-65	DOUBLE NOSE FORK	\$ 675.00 (OS)
** SMK-66	SINGLE NOSE FORK	\$ 675.00 (OS)

## SPRING STEEL (A2-A, M10) MAIN GEAR LEGS

*\*\*\*FAA - STC'd - w/337*

*** SMK-67	DOUBLE NOSE FORK	\$ 775.00 (OS)
------------	------------------	----------------

**Specify type of MAIN GEAR when ordering and also if you have CLEVELAND BRAKES.**  
New simplified design is stronger, lighter and easier to install.

**Not compatible with Landing Light Kits that install on gear legs.**

Flared wheel openings permit easy access to tire valves with no sacrifice in stream lining.

**Main gear fairings are fully articulated and remain level at all times. Strut action is not restricted.**  
Increase cruise speed 3 MPH. No affect on aircraft trim, control or C.G.

**No sturdier fairing is made!**

Basic fairings are fabricated of a combination fiberglass mat and cloth impregnated with Polyester Resin.  
Ready for final finishing, paint and trim.

**Kit includes necessary components for immediate installation. Parts simply bolt on. Fiberglass units shipped filled, sanded and primed. DEDUCT 15% if you do not wish to have this done for you prior to shipment.**  
Oversized Shipment Required (OS)

## NOSE LANDING GEAR / STEERING

<u>PART NUMBER</u>	<u>DESCRIPTION</u>	<u>PRICE</u>
<b>A. <u>KITS and MODIFICATIONS</u> OS (OVERSIZE SHIPMENT)</b>		
FMK 17	DOUBLE ARM NOSE FORK 34371-2, with AXLE, CUPS, SPACERS, 500 X 5 WHEEL, TIRE & TUBE - for STEEL NOSE GEAR - To be used on S/N 4423 and earlier .....	\$ 1,410.00
FMK 17D	Same as above with INNER CYLINDER installed.....	\$ 1,670.00
FMK 17DW	Same as above with INNER CYLINDER installed but without TIRE, TUBE & WHEEL	\$ 1,010.00
FMK 17E	DOUBLE ARM NOSE FORK KIT - For ELECTROL GEAR, S/N: 4424 & UP With 500X5 WHEEL installed.....	\$ 623.80
FMK 17EB	Same as FMK17E for ELECTROL GEAR with 500 X 4 WHEEL.....	\$ 895.00
FMK 17EC	Same as FMK 17E ELECTROL GEAR with INNER CYLINDER installed.....	\$ 1,348.50
FMK 17F	FORNEY / ALON FORGED ALUMINUM SCISSORS - For SINGLE FORK STEEL GEAR (Complete with BUMPER and all HARDWARE) .....	\$ 546.55
FMK 17H	Same as FMK-17 without TIRE, TUBE and WHEEL .....	\$ 644.00
FMK 24	FORNEY / ALON OUTER CYLINDER ASSEMBLY WITH PISTON HEAD, STEERING COLLAR, SLEEVE, and LOWER BUSHING. For ELECTROL items no longer available .....	\$ 1,566.00
FMK 25	FORNEY / ALON TYPE NOSE GEAR. (Assembled) with SCISSORS, CYLINDERS, DOUBLE ARM FORK, 500 X 5 WHEEL 6-PLY TIRE and TUBE. Fits all models .....	\$ 4,325.00
FMK 101	NOSE GEAR STEERING BALL CONVERSION KIT (M-10 DESIGN) Substitutes FEMALE ROD END BEARING - PUSHROD must be one of two listed next	\$ 74.50
FMK 101 with 52035	NOSE GEAR STEERING BALL KIT with PUSHROD .....	\$ 189.90
52035	PUSHROD (415-C, 415-CD, 415-D, E, G, F-1) .....	\$ 157.10
52479-9	PUSHROD (F-1A, A-2, A-2A, M10).....	\$ 73.90
HF6M	REPLACEMENT ROD END BEARING and LOCKNUT. For a failed BEARING that was installed in the past, but now needs replacement.....	\$ 19.50
SMK 6	NOSE GEAR OLEO PISTON BOOT KIT complete with SS CLAMPS.....	\$ 18.45
SMK 6A	NOSE GEAR OLEO PISTON BOOT ONLY (No CLAMPS).....	\$ 13.70
SMK 33*	NOSE GEAR REBUILD - STEEL, SINGLE FORK .....	\$ 55.50
SMK 33D*	NOSE GEAR REBUILD - STEEL, DUAL FORK .....	\$ 42.50
SMK 33S	STEEL SCISSORS REBUILD with BOLTS and BUSHINGS SINGLE FORK .....	\$ 118.83
SMK 33SD	STEEL SCISSORS REBUILD for DUAL FORK.....	\$ 118.83
SMK 33SU	STEEL SCISSORS REBUILD for UNIVAIR STRAP type DUAL FORK .....	\$ 118.83
SMK 33E4*	NOSE GEAR REBUILD for ELECTROL - SINGLE FORK 500X4 .....	\$ 44.95
SMK 33E5*	NOSE GEAR REBUILD for ELECTROL - SINGLE FORK 500X5 .....	\$ 53.27
SMK 33DE*	NOSE GEAR REBUILD for ELECTROL - DUAL FORK .....	\$ 31.95

\* Lower Bushings PN: 34133 or 34315 must be ordered separately.

**We also carry many hard to find parts for the "ELECTROL" NOSE LANDING GEAR. Factory installed on Models 415-D, 415-CD, E, G, F-1, SERIAL NUMBERS 4424 through 5674.**

**Need a TOW BAR ? See PAGE 2.**

<u>PART NUMBER</u>	<u>DESCRIPTION</u>	<u>PRICE</u>
SMK 33F	NOSE GEAR REBUILD - DUAL FORNEY / ALON TYPE (LESS LOWER BUSHING, P/N 34411) .....	\$ 56.75
SMK 33FX	ALUM SCISSORS REBUILD WITH BOLTS & BUSHINGS.....	\$ 59.50
SMK 33SX	ALUM SCISSORS REBUILD FOR STEEL GEAR SINGLE FORK .....	\$ 58.50
SMK 55G	NLG STRUT TO ENGINE MOUNT ATTACH.....	\$ 6.45

**B. PARTS and MISCELLANEOUS**

530062 000	SNUBBER CABLE – M10 DESIGN.....	\$ 51.64
AFA 396	NEW FIRESTONE 500X5 BEARING RETAINER ASSEMBLY. Need 2 a wheel..... (each)	\$ 15.00

**CLEVELAND 500 X 5 NOSE WHEEL PARTS are available. BEARINGS, SEALS, RINGS, etc.  
We also carry some ELECTROL NOSE GEAR PARTS. Most are USED but some new still available.  
Parts for F-1 thru M10 Style NOSE LANDING GEAR ASSEMBLIES are almost always available.**

**415-C STEEL NOSE GEAR PARTS (Refer to Ercoupe Service Memorandum 41, 61)**

31058S*	STEERING PUSHROD BOOT.....	\$ 19.75
34019	SCISSORS - LOWER - FACTORY NEW!! .....	\$ 320.10
34043	SCISSORS - UPPER -NEW!! .....	\$ 272.71
34029	UPPER STEERING COLLAR ...(415/F1/A2/M10) .....	\$ 305.10
34041	TAXI SPRING .....	\$ 14.95
34042	NYLON NUTCRACKER BUSHING..... (Need 2) ... (each)	\$ 10.30
34051	SPACER WASHER, LAMINATED .040.....	\$ 12.18
34057	LOWER STEERING SLEEVE .....	\$ 368.70
34080	OUTER CYLINDER.....	\$ 547.00
34086	SHOCK ABSORBER INNER BUSHING for OUTER CYLINDER .....	(OS) \$ 21.29
34087	SHOCK ABSORBER - INNER PISTON.....	\$ 7.37
34089	OLEO STRUT OIL GAUGE ASSEMBLY .....	\$ 13.40
34094	NUTCRACKER BUMPER.....	\$ 4.92
34099-2	CYLINDER ROD and HEAD ASSEMBLY.....	\$ 411.00
34109	AXLE LOCK NUT.....	\$ 7.95
34110-3	AXLE LOCK WASHER.....	\$ 1.05
34126-1	OIL SEAL.....	\$ 6.36
34127	ORIFICE FITTING OLEO PISTON .....	\$ 57.92
34128	SUPPORT FLANGE .....	\$ 34.73
34129	OIL SEAL SUPPORT .....	\$ 197.50
34130	INNER CYLINDER (HARD CHROME) .....	\$ 602.00
34133	LOWER FLANGE BUSHING.....	\$ 138.60
34133-1	LOWER BUSHING O-RING (AN6227-31/MS28775-328).....	\$ .88
34134	NUTCRACKER BUSHING – STEEL..... (Need 2) ... (each)	\$ 47.59
34200-1	SINGLE WHEEL BEARING.....	\$ 41.25
AN4 33A	WHEEL BOLTS - (34212)..... (Need 3 Per Rim) ... (each)	\$ 1.75
AN510 6R4	SCREW NLG INNER CYL ATTACH...(640 THREAD..... (Need 4) ... (each)	\$ .09
MS35191 268	SCREW NLG OUTER CYL ATTACH.....(1032) .....	(Need 4) ... (each) \$ .58
MS35265 24	SCREW - FILISTER HEAD - LOWER BUSHING..... (Need 4) ... (each)	\$ 4.35

\* 337 REQUIRED, ORIGINAL PARTS are no longer available.

Need a TOW BAR? See PAGE 2.

## FLIGHT CONTROLS / SURFACES

<u>PART NUMBER</u>	<u>DESCRIPTION</u>	<u>PRICE</u>
<b>A.</b>	<b><u>KITS and MODIFICATIONS</u></b>	<b>OS (OVERSIZE SHIPMENT)</b>
FMK 2	WING ATTACH HARDWARE – Complete set; front & rear, left & right.....	\$ 115.95
FMK 14	RAMS HORN CONTROL HANDLE SET: 2 handles ready to finish with installation Instructions & hardware. Includes a sample 337 FORM.....	\$ 85.95
FMK 21	TEFLON CONTROL SHAFT GUIDE KIT - Forney Service Bulletin - 104.....	\$ 22.50
FMK 21T	TEFLON REPLACEMENTS for above kit FMK 21 .....	\$ 8.27
FMK 22	RUDDER RIB REPLACEMENT KIT for both sides (AD 59-25-5) .....	\$ 141.80
FMK 26	RUDDER BELL CRANK LUBE KIT for 52404 BUSHING (AD 67-6-3 ESM 63) .....	\$ 5.90
FMK 26A	RUDDER BELL CRANK NYLON BEARING for all COUPES. Replaces FMK-26.....	\$ 19.95
SMK 1	TRIM CONTROL CONVERSION KIT (Less hinged TRIM TAB) (ESM 38) .....	\$ 514.19
SMK 4	RUDDER PEDAL KIT, Service Memorandum (ESM) 59/59A 415 MODELS.....(Must have SK-75 HANDBRAKE \$ 354.60) .....	\$ 995.00
SMK 39L	LOW SPEED WARNING HARDWARE for 415C, CD or D with SPLIT ELEV.....	\$ 109.50
SMK 102A*	AILERON HINGE HARDWARE .....	\$ 9.50
SMK 102AA*	AILERON HINGE HARDWARE ALON.....	\$ 9.50
SMK 102C	TRIM WIRE CONDUIT HARDWARE .....	\$ 23.25
SMK 102E*	ELEVATOR HINGE HARDWARE.....	\$ 9.45
SMK 102ES*	SPLIT ELEVATOR HINGE HARDWARE.....	\$ 12.25
SMK 102H	HARDWARE-FORWARD FUSELAGE PUSHRODS & CABLES .....	\$ 38.65
SMK 102R**	RUDDER HINGE and RUDDER ARM HARDWARE .....	\$ 31.95
SMK 102S	STABILIZER ATTACHMENT HARDWARE .....	\$ 7.50
SMK 102T	HARDWARE-TAIL SECTION PUSHRODS & CABLES .....	\$ 19.80
SMK 102V	VERTICAL FIN ATTACHMENT HARDWARE	
\$	13.50	

\* These KITS contain NEW SCREWS, NUTS and BONDING STRAPS ONLY.

\*\* Parts in this KIT comply with AD 59-25-5 9 (FMK 22).

---

**B. PARTS and MISCELLANEOUS**

14044	TIE DOWN RINGS - WING (Need 2)...(TAIL Need 1).....	(each) \$ 7.50
22007	ELEVATOR HINGE – OUTER.....	(Need 2) ... (each) \$ 12.17
22008	ELEVATOR HINGE - 8" LONG CENTER HINGE on STANDARD ELEVATOR.....	\$ 70.72
22017*	ELEVATOR ASSEMBLY-USED but with NEW SKINS, MANY NEW PARTS and All others thoroughly reconditioned (Add \$100.00 CORE).....	(OS) \$ 995.00
22031	TRIM TAB ASSEMBLY Complete ESM 38.....	\$ 241.14
22031 4	TRIM TAB PLATE - 1 3/8" WIDE (Required for C-85 Engine).....	\$ 23.60
22038	ELEVATOR HINGE 16 1/4" LONG – CENTER HINGE on SPLIT ELEVATOR .....	\$ 38.20
24003	AILERON & RUDDER HINGE.....	(Need 8 + 6 = 14 Total) ... (each) \$ 13.66
483 15	INSPECTION RINGS (AD94-18-04) .....	\$ .93
483 10	INSPECTION PLATES (AD94-18-04).....	\$ 2.70
52034	AILERON PUSH ROD .....	(Need 2) ... (each) \$ 142.90

\* ADD \$100.00 CORE. REFUNDED WITH RETURN OF REBUILD ABLE UNIT.

<u>PART NUMBER</u>		<u>DESCRIPTION</u>	<u>PRICE</u>
<b>B.</b>		<b><u>PARTS and MISCELLANEOUS</u> (Continued)</b>	
52070 33		TRIM WIRE (17 FEET).....STAINLESS .....	\$ 24.75
52107		QUADRANT CHAIN ..... (Need 2) ... (each)	\$ 42.35
52113	NEW	UNIVERSAL JOINT..... (Need 2) ... (each)	\$ 232.52
52118 6		SPROCKET SHAFT BUSHING..... (Need 4) ... (each)	\$ 1.78
52119		CONTROL COLUMN BRONZE BUSHING..... (Need 2) ... (each)	\$ 24.95
52137		QUADRANT - NEW STYLE complies with AD 54-26-2.....	\$ 193.00
52172 S		QUADRANT CABLE for 52137 Quadrant ..... (Need 2) ... (each)	\$ 59.73
52276		TRIM WIRE SWIVEL .....	\$ 14.95
52307 1		AILERON BELLCRANK BEARING (KP4A)..... (Need 4) ... (each)	\$ 16.42
AN386 1 6		UNIVERSAL JOINT FORWARD TAPER PIN ..... (52117 16) (Need 2) .....	\$ 9.20
AN386 1 7	NEW	UNIVERSAL JOINT AFT TAPER PIN ..... (52070 30) (Need 2) ... (each)	\$ 16.50
AN975 3		WASHER for AN386 1 6 TAPER PIN ONLY .....	(Need 1 per pin) .. \$ 1.15
GMM-3M-670		HEIM ROD END BEARING (Total 11 on aircraft)... <b>FAA-TSO</b> (replaces MD36 14M) ...	\$ 15.25

---

**SKYPORT has a wide range of NEW OLD STOCK (NOS) and good USED WING and CENTER SECTION RIBS, STIFFENERS, BRACES and other parts. Call for SPECIAL PRICES and AVAILABILITY.**

---

## Cover Photo

Credit for our May 2005 cover photo goes to Alan Fairclough of Kingwood, Texas, who owns this Ercoupe serial number 506 circa 1946. Production ended for this series with serial number 812.

This Ercoupe is seen sitting the late afternoon Texas sun. Alan sent this photo on CD along with other photos and text. They will be the fledgling start to a SKYPORT WEBSITE which is still in development.

Thanks Alan.



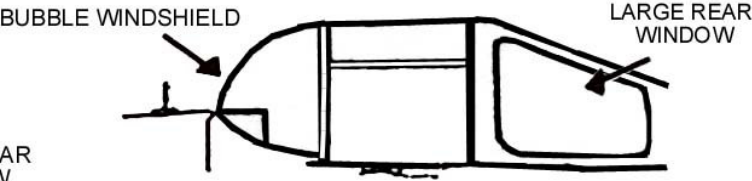
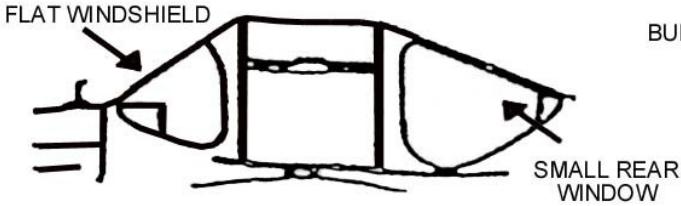

<u>PART NUMBER</u>	<u>DESCRIPTION</u>	<u>PRICE</u>
--------------------	--------------------	--------------

### WINDOWS / WINDSHIELD / CANOPY

#### A. KITS and MODIFICATIONS

**OS (OVERSIZE SHIPMENT)  
OST (OVERSIZE TRUCK FREIGHT)**

SMK 23	WINDOW WELTS (Pair)-Black .....	(set) \$ 34.75
SMK 23A	WINDOW WELT (One only)-Black .....	\$ 18.35
SMK 74	CONVERSION PARTS (Converts FLAT to BUBBLE WINDSHIELD) .....	\$ 73.50
SMK 80	INSTALLATION NUTS & SCREWS FLAT WINDSHIELD .....	\$ 32.18
SMK 81	INSTALLATION KIT SMALL REAR WINDOWS .....	\$ 22.50
SMK 82*	LARGE REAR WINDOW MOLDING/LOCKBEAD (BOTH SIDES) .....	\$ 29.50
SMK 83*	SMALL REAR WINDOW MOLDING/LOCKBEAD CONVERSION...(BOTH) .....	\$ 25.50

### 415-C, -CD, -D, E, G, F-1, F-1A, A-2, A2-A and M10 ACRYLIC or LEXAN WINDOWS, WINDSHIELDS and CANOPY UNITS

LP350C*	FLAT WINDSHIELD-CLEAR .....	(OS) \$ 136.50
LP350G or LP350S	FLAT WINDSHIELD-TINT GREEN or GREY .....	(OS) \$ 163.80
LP351C	BUBBLE WINDSHIELD-CLEAR .....	(OS) \$ 256.00
LP351G or LP351S	BUBBLE WINDSHIELD-TINT GREEN or GREY .....	(OS) \$ 307.20
53041	SIDE WINDOW 415/FORNEY-CLEAR LEXAN .....	(OS) \$ 78.93
LP352C	SIDE WINDOW 415/FORNEY-CLEAR ACRYLIC .....	(OS) \$ 42.50
LP352G or LP352S	SIDE WINDOW 415/FORNEY-GREEN or GREY ACRYLIC .....	(OS) \$ 51.00
LP354C	SUNSHADE-415/FORNEY-CLEAR .....	\$ 34.50
LP354G or LP354S	SUNSHADE-415/FORNEY-TINT GREEN or GREY .....	\$ 41.40
LP354B	SUNSHADE-415/FORNEY-TINT DARK BRONZE .....	\$ 41.40
LP356C	REAR WINDOW-SMALL CLEAR .....	\$ 35.20
LP356G or LP356S	REAR WINDOW-SMALL TINT GREEN or GREY .....	\$ 42.25
LP358C**	REAR WINDOW-LARGE .....	\$ 36.80
LP358G or LP358S**	REAR WINDOW-LARGE TINT GREEN or GREY .....	\$ 44.15
LP803C or LP804C	REAR CANOPY M10 LH/RH M10-CLEAR .....	\$ call
LP803G or LP803S	REAR CANOPY M10 LH-TINT GREEN or GREY .....	\$ call
LP804G or LP804S	REAR CANOPY M10 RH-TINT GREEN or GREY .....	\$ call
LP870C or LP871C	WINDSHIELD A2/M10 LH/RH-CLEAR .....	(OS) \$ call
LP870G or LP870S	WINDSHIELD A2/M10 LH-TINT GREEN or GREY .....	(OS) \$ call
LP871G or LP871S	WINDSHIELD A2/M10 RH-TINT GREEN or GREY .....	(OS) \$ call
LP872C or LP873C***	REAR CANOPY A2 LH/RH-CLEAR .....	(OS) \$ call
LP872G or LP872S***	REAR CANOPY A2 LH-TINT GREEN or GREY .....	(OS) \$ call
LP873G or LP873S***	REAR CANOPY A2 RH-TINT GREEN or GREY .....	(OS) \$ call
LP874C	CANOPY A2/M10-CLEAR (Freight shipment only) .....	(OST) \$ call
LP874G or LP874S	CANOPY A2/M10-TINT GREEN or GREY (Freight shipment only) .....	(OST) \$ call

\* KIT INCLUDES LOCK BEAD TOOL and SAMPLE 337s.

\*\* To install the LARGE REAR WINDOW, the aircraft must be equipped with a FLAT HAT SHELF or LARGE BAGGAGE COMPARTMENT.

\*\*\* Includes ACRYLIC RUB STRIPS, A-2 Part Number 13250-93 or A-2A Part Number 340234 093.

<u>PART NUMBER</u>	<u>DESCRIPTION</u>	<u>PRICE</u>
<b>B.</b>	<b><u>PARTS and MISCELLANEOUS</u></b>	<b>OS (OVERSIZE SHIPMENT)</b>

**ADDITIONAL WINDOW ITEMS**

31250	REAR WINDOW MOLDING and LOCK BEAD (Per Foot) .....	\$ 2.00
110	LOCKBEAD TOOL for LOCK BEAD MOLDING .....	\$ 8.30
SS31130	LOWER WINDSHIELD WEATHERSTRIP (For <i>FLAT</i> or <i>BUBBLE WINDSHIELD</i> ).....	\$ 6.40
CH35	SEALING U-CHANNEL – REAR WINDOWS (Foot) .....	\$ 0.41
CH201	SEALING U-CHANNEL FLAT WINDSHIELD BOW (Foot).....	\$ 0.53
SEALSTRIP	SEALSTRIP for BUBBLE WINDSHIELD BOW (11 FT X 1 1/2 X 3/64) .....	\$ 10.85
D18*	DRILL BIT 1/8" .....	\$ 3.44
D532*	DRILL BIT 5/32" for Plexiglas .....	\$ 4.85
D316*	DRILL BIT 3/16" .....	\$ 4.38
EC1055	ALON/M10 RUBBER TUBE CANOPY SEAL .....	(Foot) \$ 2.25

\* **DRILL BITS – SPECIAL GROUND for ACRYLICS. 1/8", 5/32" or 3/16". Other sizes available upon request.**

**A-2, A2-A and M10 CANOPY LATCHES, CATCHES SLIDES, GLIDES and ROLLERS are available in limited quantities. Call now for availability and pricing. Other parts for your CANOPY system are still available too!**

**415 SLIDING WINDOW PARTS**

53048	HANDLE OUTSIDE (Need 2, one on each window or sunshade).....	(each) \$ 16.95
53051	FEMALE FRAME (Need 2 on each RH window, and sunshade).....	(each) \$ 26.31
53052-3	MALE FRAME (Need 1 on each LH window or sunshade .....	\$ 29.09
53052-3	BOTTOM END FRAME (Need 2, one on each window).....	(each) \$ 29.09
53022-2	BOTTOM END STIFFENER (Need 2, one on each window).....	(each) \$ 13.40
53075-1	HANDLE INSIDE (Need 4, two on each window and 4 per sunshade .....	(each) \$ 13.50
53076	WINDOW LATCH THUMB SCREW (Need 2) LH & RH.....	(each) \$ 2.85
<del>53082</del>	<del>NEW THUMB SCREW TENSION PLATE (Need 2) LH &amp; RH.....</del>	<del>Not available</del>
AN366-1032	ANCHOR NUT WINDOW LATCH THUMB SCREW (Need 2) .....	(each) \$ 2.66

MGH 10	MEQUIAR'S PLASTIC POLISH – Cleans and polishes windows and canopies. NON-GLARE, NON- STATIC, NON-ABRASIVE (8 OZ) .....	\$ 9.17
MGH 17	MEQUIAR'S PLASTIC CLEANER – Slightly abrasive, removes tiny scratches (8 OZ) .....	\$ 9.17

**REMEMBER!!!**

Our PRICE LIST CATALOG covers only the most frequently required kits, parts and literature. If what you need isn't included call our **TOLL FREE NUMBER: 1-800-624-5312**. We may have what you are looking for **in stock**, a **serviceable used part** or be able to **obtain it for you** from another source.

The **LAST** part of our business name is, **“SERVICES”**  
but it's **FIRST** when serving **YOU**.



SECTION 1  
AIRCRAFT GENERAL  
MISCELLANEOUS

SECTION 10  
WINDOWS / WINDSHIELD

SECTION 9  
FLIGHT CONTROL

SECTION 9  
FLIGHT CONTROLS

SECTION 6  
FUSELAGE & COWLING

SECTION 2  
CENTER SECTION

SECTION 9  
FLIGHT CONTROL

SECTION 4  
ENGINE / PROP

SECTION 5  
FUEL / OIL

SECTION 8  
NOSE LANDING GEAR / STEERING

SECTION 7  
MAIN LANDING GEAR

SECTION 3  
ELECTRICAL

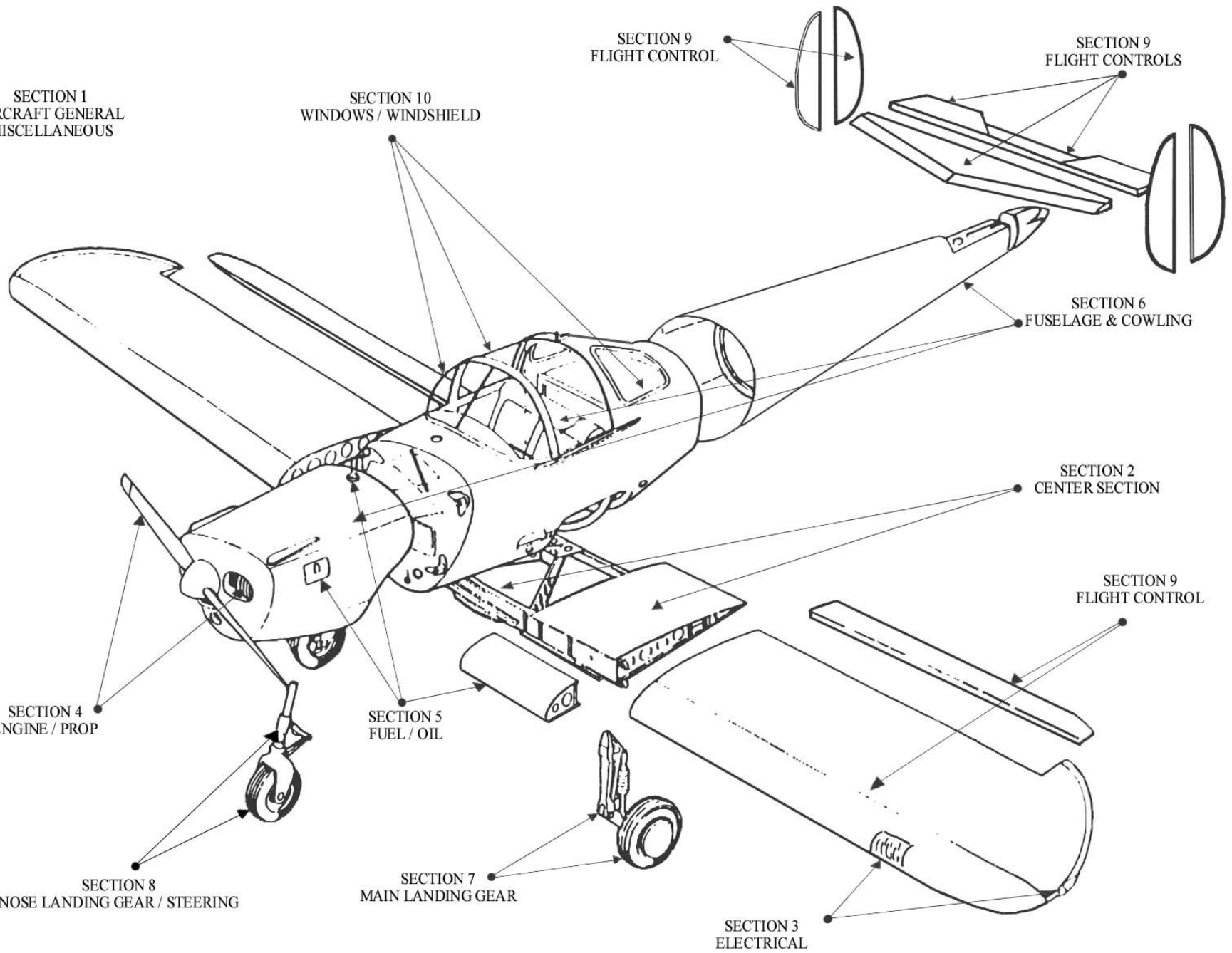

## Play it cool...with the Super Bowl!

If your 'coupe is getting hot under the cowl, the FIBERGLASS BOWL may be the answer to your problems. Larger "gills" improve cooling of the cylinder heads, and the recessed intake below the prop assures a constant flow of cool ram air along the bottom of the crankcase and to the oil sump. No loss in performance.

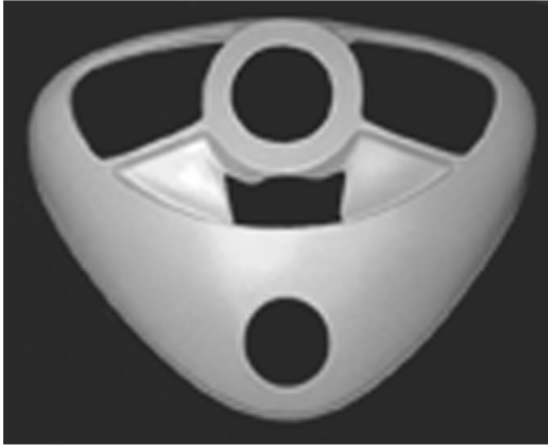

\* Straight from the mold - un-sanded and un-primed - you'll sand and prime after fitting

KIT NO. SMK-72

**\$ 329.00**

KIT NO. SMK-73

(With cabin air fitting)

**\$ 354.00**

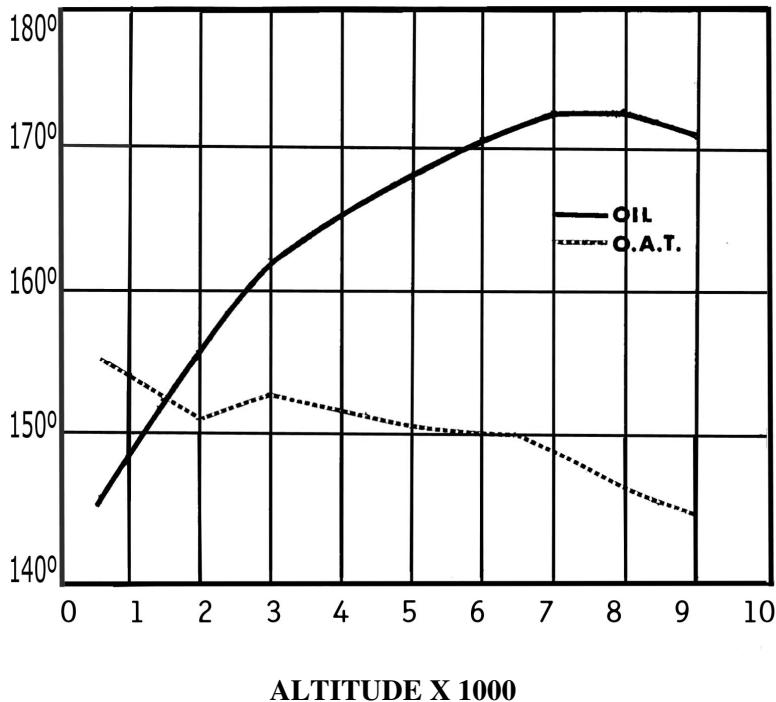

### FAA TEST RESULTS

Aircraft: Ercoupe 415CD  
Engine: Continental C-90  
Wt. @ T/O: 1478 lbs.  
Field temp: 71°F  
Field altitude: 63 ft.  
Climb range: 600' to 9000'  
Power setting: Full throttle  
Climb speed: 70 mph  
Time to climb: 26 min.  
Max oil temp.: 173°F  
Max cyc. head temp:  
#1: 461°F  
#2: 454°F  
#3: 414°F  
#4: 359°F  
(max. allow = 525°F)

Fully approved and STC'd by the FAA (Requires 337). Quality crafted of fiberglass mat and cloth, laminated in flame retardant resin. Finished in Gel-Coat. No increase in weight. No increase in aerodynamic drag. Shipped via UPS Oversize.