

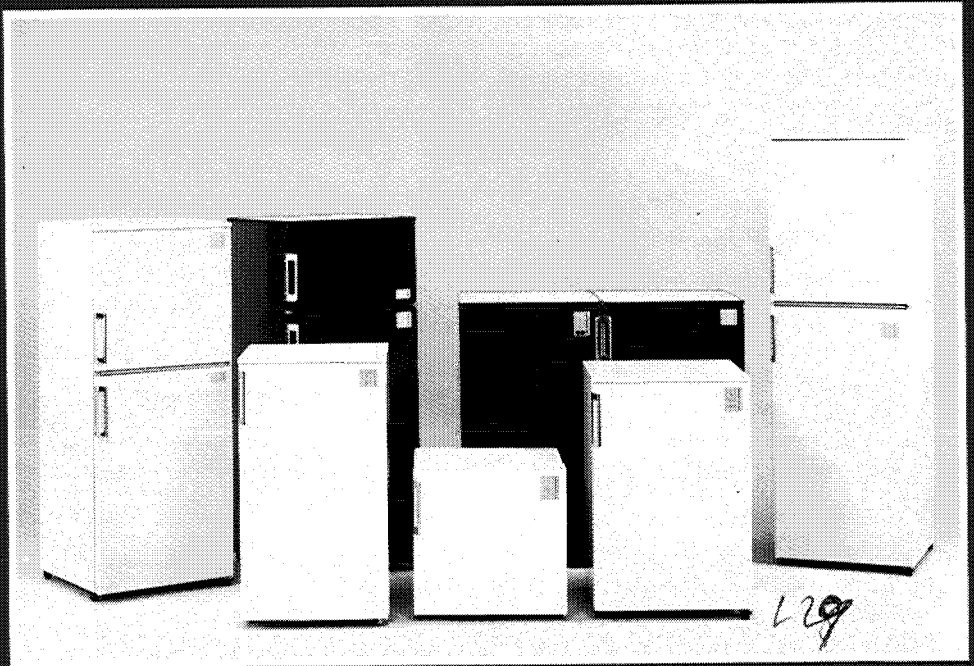

# Electrolux

## **FREEZER/REFRIGERATOR TR915A**



### **User's Handbook**

Your new Electrolux freezer/fridge has two separate compartments. The automatically defrosted fridge compartment is at the top; the freezer compartment at the bottom will store frozen food and freeze quantities of fresh food.

For best results, it's important that you read all the contents of this handbook before you use your freezer/fridge.

At first you may be aware of sounds in your kitchen which you are not used to, particularly if your freezer/fridge is against sound-reflective surfaces such as tiled or painted walls. Please remember the cooling unit includes precision-built components which, like those in car engines and other machinery with fast moving parts, need a running-in period which may last for several weeks. During this period, don't worry, — just allow the appliance time to settle down.

Before using your freezer/fridge for the first time, we advise you to wash the inside and fittings as described on page 15, under "Cleaning".

- 1 **Butter & cheese compartment**
- 2 **Thermostat control**
- 3 **Cooling plate**
- 4 **Drink cooler**
- 5 **Defrost drain**
- 6 **Salad drawer**
- 7 **Door shelf & bottle gripper**
- 8 **Ice store**
- 9 **\*Freezing/storage shelf**
- 10 **\*Storage shelf**
- 11 **Storage drawer**
- 12 **Defrost flip spout**
- 13 **Level adjusters (in feet)**

\*Lift plastic flap to open

## **SAFETY NOTE**

If this appliance is replacing an old one which is going to be scrapped, please remove the door or lid before disposal to prevent children from becoming trapped inside.

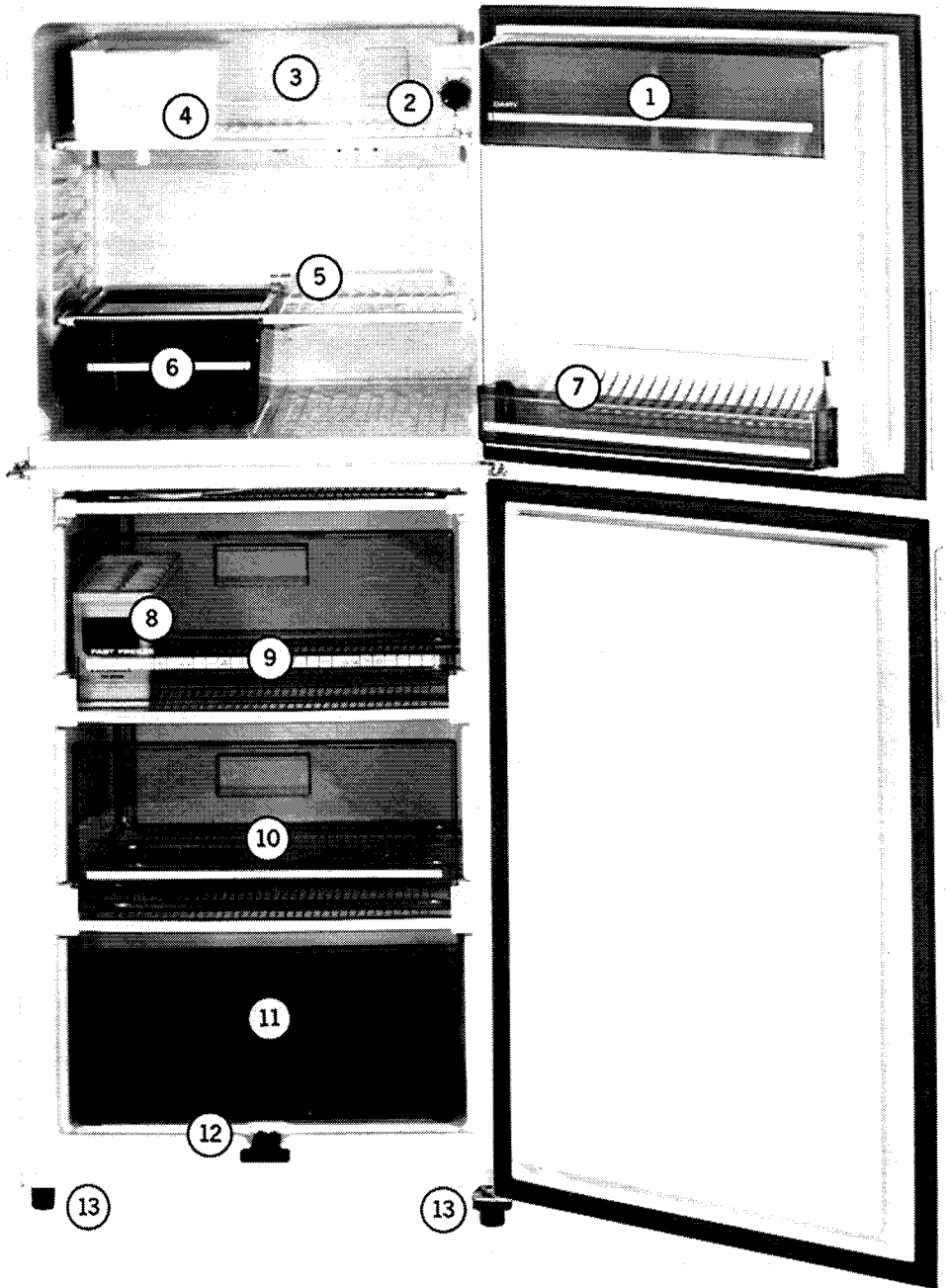

# About your freezer/fridge

## Where to install it

The chosen position for your freezer/fridge may make it preferable to change over the hinges and door handles to reverse the door hang. To do this, refer to 'Changing over the door hinges' on page 16.

For the cooling unit to work efficiently, your freezer/fridge should be located in a dry atmosphere, out of direct sunlight and away from extreme temperatures, e.g. not next to a cooker or other sources of direct heat, or in a very cold room e.g. an outhouse, where the temperature may fall below 6°C (43°F).

Leave a clearance of at least 50mm (2ins) above the cabinet and do not obstruct the space underneath. The back of the cabinet may be placed close to the wall but should not touch it. Do not install in a small pantry or other places with restricted ventilation.

Your freezer/fridge will be heavy when loaded with food and must therefore be stood on a strong firm floor. It should also be level. Adjust the level by screwing out the appropriate level adjusters in the

feet using your fingers or a spanner.

**Make sure the appliance is upright and all adjusters are in firm contact with the floor so that the cabinet does not rock in any direction.**

## Connecting to the mains

Check that the voltage shown on the data plate conforms with your mains supply.

### WARNING —

**THIS APPLIANCE MUST BE EARTHED.**

### IMPORTANT

The wires in the mains lead of this appliance are coloured in accordance with the following code:-

<b>GREEN-and-YELLOW</b>	: <b>EARTH</b>
<b>BLUE</b>	: <b>NEUTRAL</b>
<b>BROWN</b>	: <b>LIVE</b>

If a 3 pin 13 amp fused plug is used, it should be fitted with a 13 amp fuse; with other plug types, the circuit should contain a 10 amp fuse.

As the colours of the wires in the mains lead may not correspond with the coloured markings identifying the terminals in your plug, proceed as follows:-

Connect the GREEN-and-YELLOW coloured wire to the plug terminal marked letter E or earth symbol  $\perp$  or coloured green or green-and-yellow.

Connect the BLUE coloured wire to the plug terminal marked letter N or coloured black.

Connect the BROWN coloured wire to the plug terminal marked letter L or coloured red.

If at any time a replacement mains lead is required, the cross sectional area of its conductors must not be less than 0.75mm<sup>2</sup>.

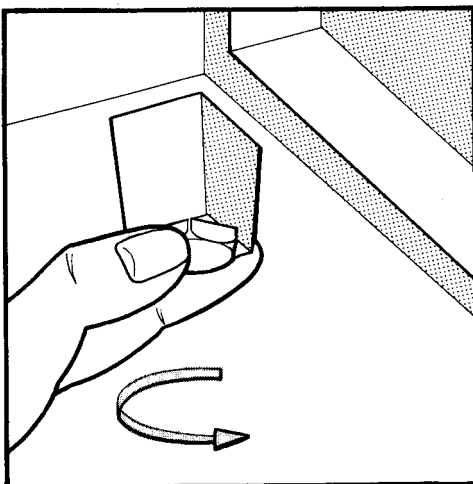

# Setting the control

To start the cooling system, plug into the wall socket, switch on and turn the thermostat knob to setting 3.

The fridge and freezer compartment temperatures will be affected by location, room temperature and frequency of door opening, and adjustment of the thermostat setting may be needed to allow for this.

When operating, the outside, front edges of the freezer may feel warm to the touch. This is quite normal.

***We advise you to run your freezer/fridge for a day before storing frozen food.***

## Temperature control

With the thermostat knob set to 3, the temperature in the refrigerator will be suitable for the storage of most fresh foods, salad vegetables, milk, certain wines and other drinks, while the freezer temperature will be suitable for the long term storage of frozen foods under most conditions of use.

If a lower temperature is needed (e.g. during hot weather), turn the thermostat knob to a higher number or, for less cooling, to a lower number.

The required temperature inside the fridge compartment is from 0°C to 7°C (32°F to 45°F) and inside the freezer compartment is -18°C (0°F) or below.

During prolonged periods of abnormally hot weather, if the thermostat is set on too high a number, the cooling system may operate continuously and the fridge compartment cooling plate may not defrost. Turning the knob to a lower number will cause automatic defrosting to resume.

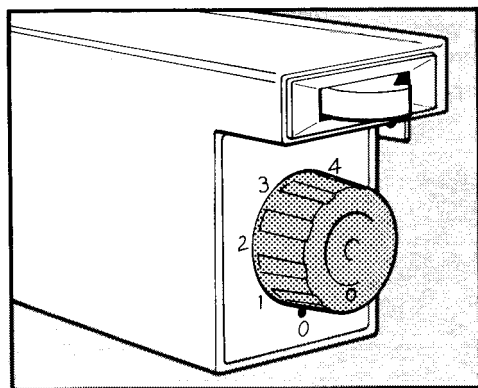

# Using the fridge compartment

The fridge compartment provides suitable shelf space to store most kinds of fresh food and has a usable storage capacity of 98 litres (3.5 cu. ft.).

## Suggested fresh food storage times

Storage times will vary according to the type of food and how fresh it is when put into the fridge compartment but no food should be stored for longer than the times stated opposite.

## Drink cooler

The drink cooler has a capacity of approximately 3 litres.

Fill the drink cooler with your favourite fruit drink, diluted squash, etc. and position it towards the front of the upper cabinet shelf with its spout protruding through the bars.

To dispense a drink, simply hold a glass under the spout and push in the button.

**IMPORTANT.** Clean your drink cooler regularly to prevent a build-up of sugary deposits. If deposits do form, soak in warm water until they dissolve then pour fresh water into the container and operate the dispenser button a few times to ensure it is free.

## Suggested maximum storage times

Type of food	Storage time
<b>Uncooked fresh meat</b>	
poultry, beef, and lamb	3 – 5 days.
pork	2 – 4 days.
sausages	3 days.
mince & offal	1 – 2 days.
<b>Cooked meat</b>	
ham, sliced meat	2 – 3 days.
pies	1 day.
casseroles & paté	2 days.
poultry	2 – 3 days.
<b>Bacon</b>	1 week.
<b>Dairy produce</b>	
milk	2 – 3 days.
cream	1 week.
butter	3 – 4 weeks.
hard cheese	3 – 4 weeks.
soft cheese	1 week.
<b>Vegetables &amp; Salads</b>	1 week.
<b>Fruit</b>	2 weeks.

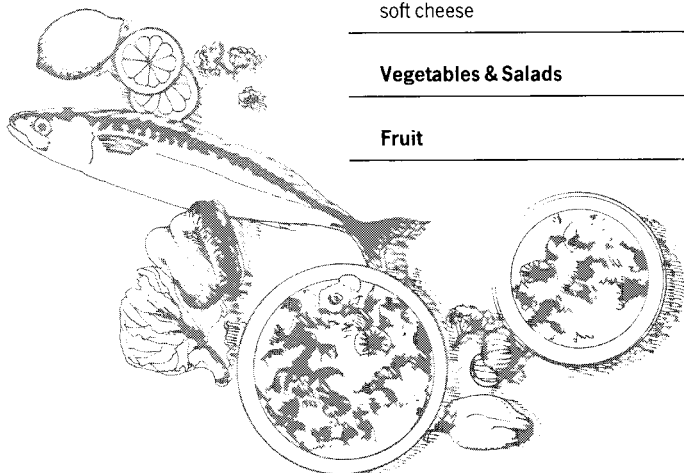

# Using the freezer compartment

The  symbol means that your freezer will store food at  $-18^{\circ}\text{C}$  ( $0^{\circ}\text{F}$ ) for long term storage and will also freeze fresh food.

## Storing frozen food

Your freezer compartment has the following capacities:

Nett Storage Volume 101 litres (3.6 cu ft).

\*Weight of Stored Food 32.3 kg (71 lb).

*\*(This is a standard measurement and the actual capacity depends upon the density and sizes of food. The above figures are based on an average density of 0.32 kg per litre).*

Pre-packed commercially frozen food should be stored in accordance with the manufacturer's instructions for 3 star frozen food compartments and should be put into the freezer as soon as possible after purchase. Your freezer provides for long term storage which generally means up to 3 months but the length of storage time can vary and it is important to follow the recommended times shown on packets of commercially frozen food.

Storage times for home prepared fresh frozen foods are given on Pages 10, 11, and 12. For your convenience, maximum storage periods for popular home frozen items are also given, in months, on the plastic flap at the front of the freezing shelf.

***If your freezer/fridge breaks down or the power fails, don't open the freezer door and the frozen food won't be affected for up to 24 hours.***

Any frozen food which is allowed to thaw accidentally should either be eaten as soon as possible or thrown away. Alternatively, if the food is uncooked and it has not been completely defrosted it can be cooked then refrozen. (Note that some items must be thawed completely before cooking — see page 13).

***Defrosted cooked food must never be refrozen.***

# Freezing fresh food

## General information

In any 24 hours you can freeze as much as 12 kg (26.5 lb) of fresh food.

Existing frozen foods should be re-arranged to leave space on the top shelf for freezing. The packets to be frozen (see pages 8 and 9) should be placed on the top shelf in contact with the refrigerated surface as far as possible and spaced apart to allow cold air to circulate between them. They should not touch existing packets. Leave the thermostat at its usual setting.

When the food has frozen (which will take up to 24 hours, depending on the amount), transfer it to the other shelf or the plastic drawer, if there is room, to leave space on the top shelf for further freezing.

## Practical Hints

Different foods need different methods of preparation and some will keep longer than others.

Of course, you can freeze practically anything, but don't waste space in your cabinet by storing foods which are readily available throughout the year.

Fruit is ideal — especially the softer varieties. But avoid pears because they lose their texture and discolour and bananas which will turn black.

Vegetables and herbs too are ideal, but salad vegetables and marrows are unsuitable because they contain too much water. Celery loses its crispness, so should be cooked first, and tomatoes are best frozen as purée. Onions should be chopped fine and frozen in small quantities.

All poultry, meat and fish freeze well, as do baked goods, though for shorter periods.

As for prepared foods, these too can be frozen with confidence, but there are a few points to bear in mind.

Semi-liquid foods have a tendency to thicken, so should be made up a little slacker than normal. Highly spiced and aromatic dishes should be wrapped really thoroughly, so the flavour doesn't spread to your other frozen foods. Always cool them quickly and then freeze immediately.

## General Preparation

For freezing purposes always choose the finest quality fresh foods.

### Fruit & Vegetables

Fruit and vegetables should preferably be frozen immediately after harvesting or at least kept in a refrigerator for no longer than twenty-four hours. For perfect results fruit should be *just* ripe, and if any shows signs of being damaged it should be discarded. Most vegetables and some fruit need to be blanched before freezing to retard enzyme reaction. Timings for individual types are given in the detailed tables that appear later in this booklet.

### Meat

Freeze joints in handy-sizes after removing waste such as bones, fat and so forth. Game must be hung for the desired period and cleaned *before* being frozen.

### Fish

Should preferably be frozen within twenty-four hours of being caught. Any superfluous scale should be removed along with the fins, then the fish gutted and washed clean in cold salted water before being frozen.

### Poultry

Gut, singe and wash birds thoroughly. Tie legs and wings to the body before placing in the freezer, or cut into joints for packing separately – giblets should be packed separately, where possible.

### Dairy Products & Baked Items

See individual details in tables which appear later in this booklet.

### Prepared Foods

These freeze well, but remember that seasonings will become intensified during frozen storage, so be very sparing and add whatever you like when ready for eating. Salt actually shortens the storage time for all types of frozen foods, so add only a little during preparation.



## Blanching

Where necessary, (see remarks column on page 11), plunge vegetables into boiling water for the specified period, timing from the moment of return to boil. Then drain and cool immediately in iced water before packaging and freezing.

## Packaging

Proper packing is one of the most important points about food freezing, if the true quality is to be preserved.

All food should be carefully wrapped in airtight moistureproof materials. It should be completely covered and as much air as possible shut out to prevent 'freezer-burn' — those blemishes which appear on thawing.

The majority of materials you are likely to require will be readily obtainable from your own home freezer supplier, the larger stationery shops and department stores. Most useful are heavy gauge polythene bags or sheeting and plastic containers with tight-fitting lids — also the thicker kinds of aluminium foil.

As far as possible, try to pack food in even shapes and sizes to maximise the space available in your freezer cabinet and facilitate removal when required at a later date.

## Labelling

The self-adhesive type of label is probably the most useful as it can be used on every kind of surface. Each label should show clearly what kind of food is in the package, its approximate weight or likely number of servings, the date of initial storage and any comments relevant to ultimate use.

In addition, keep a little notebook handy to enable you to rotate your stocks and check your family's requirements on a daily basis for future reference, so you can plan your household budget accordingly.

## Ice Making

The freezer compartment includes an ice store enabling you to build up a supply of ice cubes for a forthcoming party or spell of hot weather when ice will be in demand. The ice tray fits in the top of the store.

First, make ice cubes by filling the ice tray with fresh drinking water to the top of each ice cube compartment and placing the tray in the top of the ice store, or, for quickest ice-making, directly on the freezer shelf.

When the ice cubes have formed, hold the tray upside down over the ice store and twist the tray along its length, allowing the loosened cubes to fall into the store.

Several makings of ice cubes can be accommodated and, of course, you can also leave the ice tray full of cubes, conveniently placed on top of the ice store.

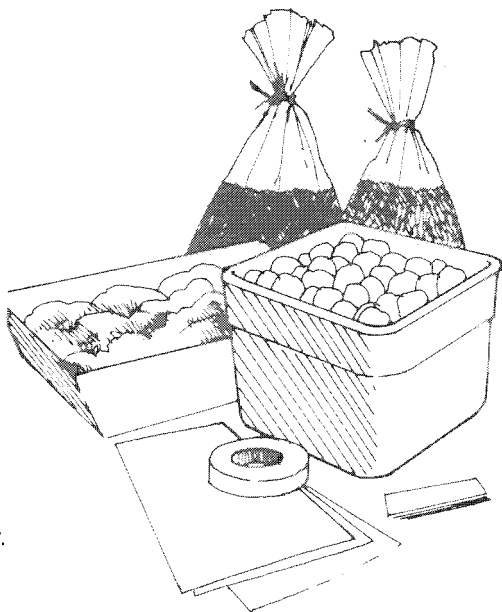

## Freezing Foodstuffs — Individual Characteristics

	<i>Max. Storage Period</i>	<i>Method</i>	<i>Remarks</i>
<b>MEAT joints</b>			
Beef	10–12 months	Cut to handy size. Wrap thoroughly	
Pork	6–9 months	Cut to handy size. Wrap thoroughly	
Lamb	9–12 months	Cut to handy size. Wrap thoroughly	
Offcut Steak	10–12 months	Separate with cellophane layers	
Chops	see Pork or Lamb above	Separate with cellophane layers	Wrap carefully to protect against puncturing by sharp bones
Veal Fillets	6–9 months	Separate with cellophane layers	
Bacon, cured smoked	6 weeks 1 month	Separate with cellophane layers	Pack in handy meal portions
Sausages	6 weeks	Wrap tightly	Pack in handy meal portions
Minced meat	2 months	Wrap tightly	Pack in handy meal portions
Offal and tripe	3 months	Clean thoroughly. Pack in small portions	Make sure it is really fresh
<b>POULTRY</b>			
Chicken	9–12 months	Clean in usual way, joint if necessary	Wrap giblets separately — do not stuff till ready
Turkey	9–12 months	Clean in usual way, joint if necessary	
Duck, Goose	6 months	Clean in usual way, joint if necessary	
Giblets	3 months		Wrap separately from bird
<b>GAME</b>			
All types	6 months	Hang before freezing, prepare as for poultry	Cook immediately after thawing
<b>FISH</b>			
All types	3–6 months	Clean, discard head and tail, wrap separately	Must be fresh
Trout	4 months	Clean, discard head and tail, wrap separately	Must be fresh
Salmon	4 months	Clean, stuff with greaseproof paper for shape retention, or cut into steaks	Must be fresh
<b>VEGETABLES</b>			
Mushrooms	12 months	Wash, dry thoroughly. Freeze loose (or sauted in a little butter till partially cooked, then freeze)	Pack viable quantities in boxes

	<i>Max. Storage Period</i>	<i>Method</i>	<i>Remarks</i>
Potatoes	10 – 12 months	New potatoes and chips can be frozen raw. Otherwise cook partially in one of usual forms, cool then freeze	
Beans	12 months	Peel or pod, and wash	Blanch for 2 mins., cool for same time in iced water then freeze
Carrots	12 months	Use small ones. Prepare	Blanch for 5 mins.
Cauliflower	12 months	Break up into florets	Blanch for 3 mins.
Spinach	12 months	Wash thoroughly. Remove thicker veins	Blanch a few leaves at a time, for 2 mins.
Sprouts	12 months	Use only small ones. Remove outer leaves	Blanch for 3 mins.
Root crops	12 months	The younger the better. Peel and slice or freeze whole	Blanch for 3 mins.
<b>FRUIT</b>			
Apples	9 – 12 months	Freeze either of two ways: As purée-stew with little water, beat to smooth pulp, sweeten to taste, cool. OR Sliced-blanch for two minutes, drain and cool. Pack tightly in layers with a little dry sugar sprinkled between, if so desired; or soak in slightly salted water for ten minutes, dry and freeze	Freeze in small quantities. Pack in plastic containers, leaving ½" headroom ditto
Apricots	10 – 12 months	Preferably remove stones, but leave skins on. Pack in syrup ½ – 1 lb. sugar to 1 pint of water, making sure fruit is covered	Pack in plastic containers, leaving ½" – 1" headroom
Cherries	12 months	ditto	ditto
Damsons	12 months	ditto	ditto
Plums	9 months	ditto	ditto
Gooseberries	12 months	ditto	ditto
Blackberries	12 months	Either pack in syrup as above, or coat with caster sugar and pack in plastic containers. Also may be frozen loose: spread on trays allowed to freeze overnight and then packed in containers	ditto
Currants	12 months	ditto	ditto
Raspberries	12 months	ditto	ditto
Strawberries	12 months	ditto	ditto

	<i>Max. Storage Period</i>	<i>Method</i>	<i>Remarks</i>
Peaches	10 months	Cover with boiling water for 1 minute, then cool by dipping into cold and peel carefully. Cut into halves, removing stone. Use syrup method of packing and freezing	Keep fruit submerged in syrup; place crumpled greaseproof paper on top, so there is no room between the surface of the liquid and the lid

### **DAIRY PRODUCTS**

Egg Whites	10 months	Eggs must always be separated. Place whites in small containers just a few at a time	Eggs frozen in their shells will crack
Egg Yolks	10 months	As for whites, but to prevent coagulation mix with ½ tsp. salt or 1 tsp. caster sugar to every two yolks	Use for savoury or sweet dishes accordingly
Butter	6 months (unsalted) 3 months (salted)	Wrap bought butter in foil and freeze	
Cream Whipping and Double only	4 months	Must first be beaten lightly before freezing	Allow slight room for expansion in the container
Cheese	8 months (soft) 3 months (hard)	Wrap all varieties tightly in foil	Hard cheese stores much better when grated

### **BAKED ITEMS Wrap in foil or polythene bags**

Bread (Freshly baked)	1 – 2 months		
Cakes, plain	6 months	Just wrap and freeze	
Cakes, iced	3 months	Freeze without wrapping, then wrap and store in polythene	

### **PREPARED FOODS**

Stews	2 months	May be frozen quite satisfactorily in a polythene bag	
Sauces	4 months	Freeze in quantities of ½ pint. A little extra liquid may be required, when you come to use it	Egg based sauces are unsuitable
Full courses	3 months	Assemble individual helpings on specially constructed aluminium trays, then cover with foil. To re-heat leave the cover on and put in the oven for about 45 minutes at 400°F (200°C)	Cover slices of meat with gravy to prevent drying out

# Thawing food

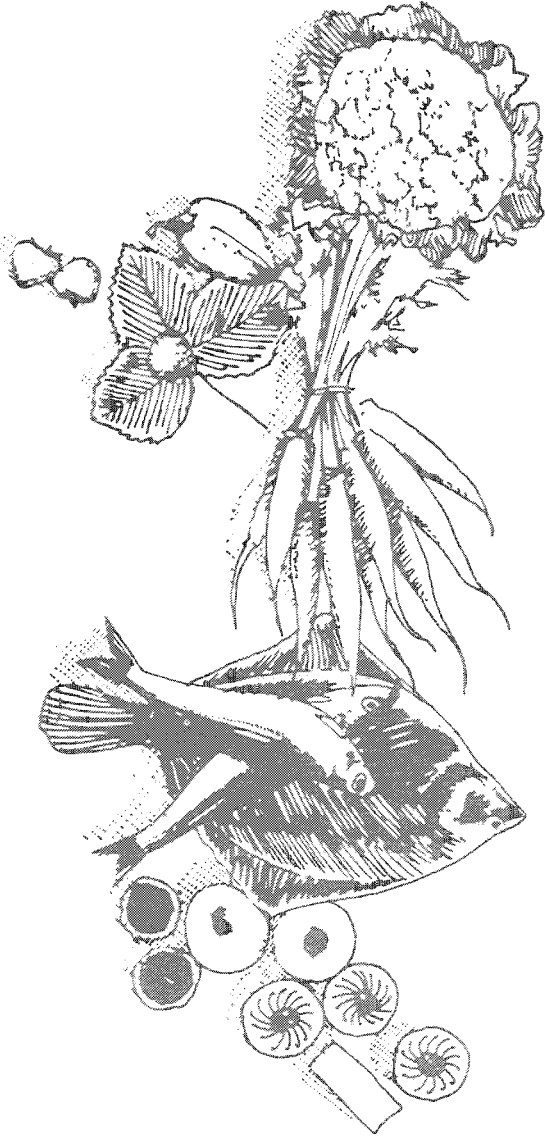

## Thawing Food

### Fruit

Keep container closed and allow to thaw at room temperature for about five hours.

### Vegetables

No thawing needed — place in salted boiling water, cover and time cooking from moment of return to boil. It only takes a few minutes. Can also be put in the oven with a knob of butter. Chips and courgettes can go into hot fat.

### Meat, Poultry etc.

Small jointed items don't require thawing before cooking, but always choose a moderate temperature and allow for a longer cooking time than normal so the meat cooks right through.

However, large items, such as a whole chicken must be thawed first; allow two to three hours per pound at room temperature, then proceed as usual.

### Dairy Products

Allow eggs to thaw in closed containers and use immediately. Butter and cream will thaw in one to two hours at room temperature.

### Baked Items

Bread takes about two hours to thaw or loaves may be heated in the oven. Cakes can be sliced in their frozen state to retain shape and speed the thawing process.

### Prepared Foods

Heat gently in closed containers in the oven.

### Commercial Packs

Simply follow the printed instructions.

# Important points to remember

## DO...

adjust the level of your freezer/fridge before loading it with food, — see page 4.

cover or wrap liquids and foods, particularly those with strong odours.

put vegetables and salads in the salad drawer, in plastic bags.

cover melons and pineapples and only store for short periods.

rotate stocks of frozen foods; date markings will help with this.

keep the refrigerator drain outlet clear; if blocked, carefully clean it with a piece of flexible curtain wire.

leave the doors ajar when the freezer/fridge is not in use.

## DON'T...

obstruct air circulation in the fridge by tightly packing stored items.

put hot food in the fridge or freezer.

let food or containers touch the refrigerator cooling plate.

store bananas in the fridge or freezer.

put bottles or cans of fizzy drinks in the freezer.

give children iced lollies straight from the freezer; they could cause frost burns.

use a sharp instrument to hasten defrosting or remove ice trays.

leave the drink cooler with residues in it which might harden or go stale. Always rinse out and dry the container as soon as it becomes empty.

# Looking after your freezer/fridge

## How to defrost

The *Fridge Compartment* is defrosted *automatically*. Defrost water from the cooling plate runs out of the drain and onto a tray on the motor compressor where it is evaporated. This process is completely automatic. Droplets of water on the cooling plate during defrosting are quite normal and will freeze on the plate afterwards.

In the *Freezer Compartment* frost accumulates on the refrigerated shelves during normal working and should occasionally be removed using a stiff bristle brush or a plastic scraper.

Heavy frosting (about 1/4" thick) will reduce the freezer's efficiency and therefore complete defrosting should then be carried out, probably at 6 month intervals depending on usage. Preferably you should do this when there is little or no food in the freezer in the following manner:

1. Any remaining frozen food should be placed in another freezer, or placed in cardboard boxes and wrapped in blankets, or layers of paper. Put in a cool place.
2. Switch off at the wall socket and remove the plug.
3. Fold out the defrost flip spout, put a suitable container under it to collect the defrost water, and leave the door open.

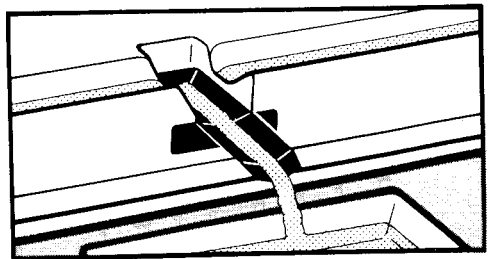

4. Defrosting can be speeded up by putting bowls of hot (not boiling) water on the shelves and loosening the frost with a stiff bristle brush or a plastic scraper.

5. After defrosting, clean and dry the interior as explained under "Cleaning" and fold back the defrost flap spout.

6. Replace the plug, switch on, replace any frozen food, and close the door.

**REMEMBER**, if the temperature of frozen food is allowed to rise unduly during defrosting, its storage life may be shortened.

### Cleaning

The most suitable time to clean your freezer/fridge is after defrosting the freezer and remember to first switch off and pull out the plug.

Both compartments and all the fittings should be thoroughly cleaned with a clean cloth wrung out in a solution of one teaspoonful of bicarbonate of soda in each pint of water.

**Never use detergents, abrasive powders, highly perfumed cleaning materials or wax polishes to clean the interior as these will damage the surfaces and leave a strong smell.**

The outside should be occasionally dusted or wiped over with a damp cloth and a small amount of detergent. But not the door seal, which should be cleaned only with soap and water and thoroughly dried.

A small amount of wax polish applied every few months will maintain the gloss finish of the outside.

The motor compressor and condenser at the rear should also be cleaned of dust occasionally using a brush, but make sure the freezer/fridge is unplugged when you do this.

Occasionally, strong smelling food may leave the fridge with a slight odour. Placing a small dish of bicarbonate of soda powder in the fridge should slowly absorb these smells. The dish should be refilled periodically.

### Going on holiday

Don't switch off at the mains if you intend to leave food in the refrigerator and/or freezer.

For 2 days or less there is no need to remove any food from the refrigerator. For up to 1 week remove all food except eggs, butter and bacon.

If you are leaving both the refrigerator and freezer compartments empty, switch off at the wall socket, defrost, clean and dry, **and leave both doors open.**

### Changing the light bulb

Should the interior light fail to work, *first switch off and pull out the mains plug*, and then replace the bulb as follows:-

Remove the light cover by pressing the top of the rear surface forward with your fingers to release the clip and at the same time pull the rear outwards toward the middle of the cabinet. Unscrew the bulb and replace it with a new S.E.S. 10 or 15 watt bulb (available from your local service shop as listed on Page 18).

Replace the cover by engaging its front edge in the recess in the light housing and depress the clip at the top of the rear and push into place.

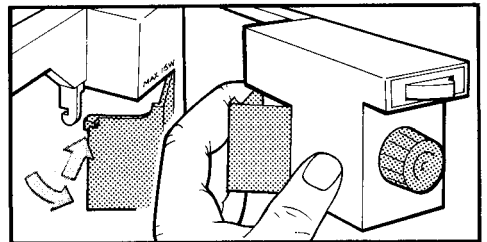

# Changing over the door hinges

1. If your freezer/fridge is already in use, disconnect it from the electricity supply and remove shelves and other loose items, including food. Place frozen food in boxes wrapped in blankets or other suitable insulating material and put in a cool place.

2. Open the upper door. While firmly holding the door with one hand, remove the screw (1) (fig. 1) which secures the hinge plate (2) and slide the bottom of the door to the right; — be ready to catch the hinge plate (2) and washer (3) as they are released.

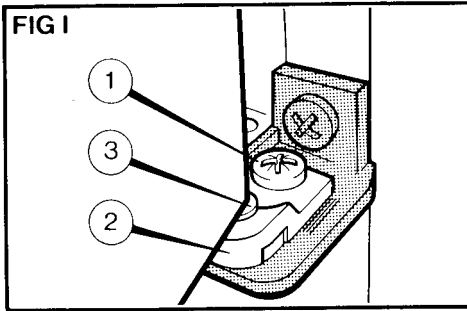

3. Carefully disengage the door from the upper hinge pin (4) (fig. 2).

4. Unscrew the upper hinge pin (4) and transfer it to the opposite side.

5. Prise off the plastic cover (5) (fig. 3).

6. Open the lower door and, holding it securely, remove the hinge pin (7) (fig. 3) which supports the top of the door, by prising it upwards. With the door closed, transfer the pin (7) to the corresponding position on the opposite side. Fit the plastic cover (5) to the hinge support at the end opposite to its original position.

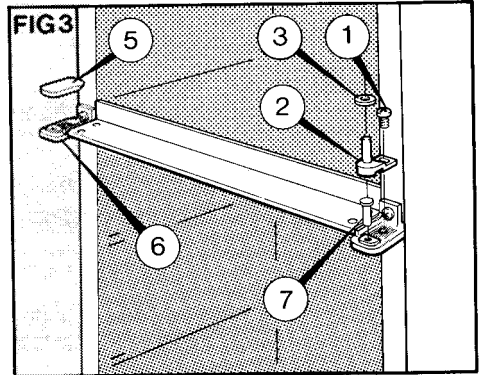
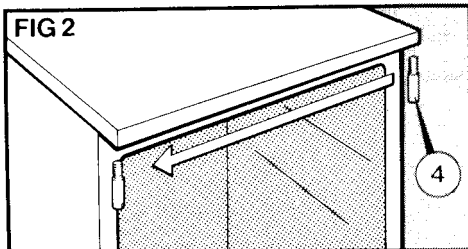

7. Refit the upper door by engaging the top of the door with the upper hinge pin (4). Place the hinge plate (2) and washer (3) (on the pin) in their new position at the bottom of the door. Engage the ribs on the underside of the hinge plate with those on the corresponding section of the support (6) (fig. 3).

8. Fit and tighten the screw (1).

9. Gently lay the appliance on its back with the top held away from the floor by at least 12 inches (use a stool or something similar). Remove level adjuster (11) (fig. 4) from the

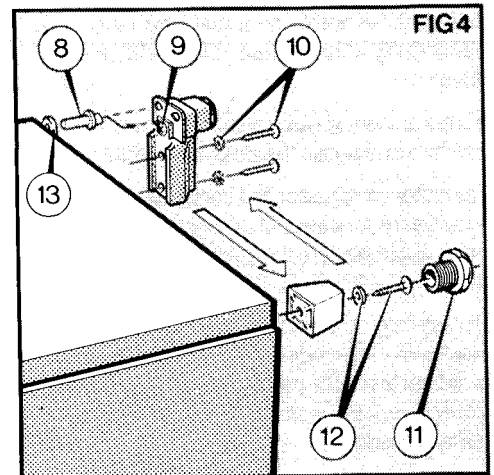



# Something not working

small foot. Remove both front feet by taking out the screw and washer (12) from the centre of the small foot, and both screws and washers (10) from the large foot. (This foot and the hinge blade will come away as a complete assembly).

**10.** Pull out the lower hinge pin (8) (fig. 4) which may have come away with the hinge blade or remained in the door. Ensure that the plastic washer (13) is on the hinge pin then push the pin (rounded end) into the bush at the bottom of the door on the side opposite to its original position.

**11.** Taking care not to press down on the door, refit the lower hinge blade/foot assembly on the opposite side with screws and locking washers (10). **Take care to ensure that the shaped end of the hinge pin enters and locates properly in the appropriate hole in the hinge blade.**

**12.** Refit the small foot, its screw entering the hole furthest from the cabinet front. Replace the level adjuster (11).

**13.** Stand the appliance upright.

**14.** Using a pocket knife blade or similar instrument, carefully prise out the plastic plugs from the alternative handle positions on the opposite sides of the doors. (Protect the paintwork from damage with masking tape or other suitable material between the blade and painted surface).

**15.** Transfer the handles to their new positions and push the plastic plugs into the vacated screw holes.

**16.** With the appliance standing on a level surface, check that the doors open and close properly and seal all round. If any adjustment is necessary, this can be done to the lower door by loosening the screw (9) securing the hinge blade to the foot and adjusting the hinge blade in or out, a little at a time, to tighten or loosen the fit. Re-tighten the screw each time an adjustment has been made before again checking for satisfactory door closure.

Side adjustment to the upper door can be made by loosening the screw (1) and moving the bottom of the door sideways a little (with the hinge plate) to the left or to the right. Be sure to support the door firmly while doing this and re-tighten the screw before testing. **Remember finally to carefully level the freezer/fridge by means of the level adjusters (11) in the feet.** — see page 4.

## **Before you call for a Service Engineer, carry out these simple checks:**

Is there a power failure? Check your house lights. If so, keep the freezer door closed until the power is restored.

Is the plug firmly connected to the wall socket and is the socket switched on? Check the power supply by plugging in another appliance or a table lamp.

Is the fuse in the plug intact and are the wires in the mains lead correctly connected to the plug? (See "Connecting to the Mains", page 4).

Have you turned the thermostat to the correct setting?

Have the doors been left open causing the temperature to rise?

Sometimes the freezer door will be difficult to open shortly after you have closed it. Don't worry; this is due to a pressure difference which will quickly equalise and allow the door to open normally.

If after checking these points, your freezer/fridge still won't work, call your nearest Electrolux Service Shop or Office without delay. It is listed overleaf.

When calling, tell us your name, address with postcode, telephone number and what appears to be wrong. Also the Model number of your freezer/fridge and when and where you purchased it.

For future reference we suggest you record these details here, and keep the receipt with the handbook as proof of purchase.

Purchased from \_\_\_\_\_

Date Purchased \_\_\_\_\_

Model Number TR915A

# Electrolux Service Organisation

Should any breakdown occur with your appliance simply telephone your nearest Service Office or Service Shop, explain the nature of your problem and quote your Model number.

## REGIONAL SERVICE OFFICES

### Scotland & North Eastern Region

Electrolux Ltd., 5 Wellington Street, Glasgow G2 6JB.  
041-204 0411

### Northern Region (Inc. N. Ireland)

Electrolux Ltd., Altham Lane, Altham, Accrington, Lancs., BB5 5XY. Padiham 74621 (STD Code 0282)

### Midlands & South Wales Region

Electrolux Ltd., 3 Strensham Hill, Moseley, Birmingham B13 8AQ.  
021-449 5252

### London Region

Electrolux Ltd.,  
842 Coronation Road,  
Park Royal, London NW10 7QA.  
01-965 9699

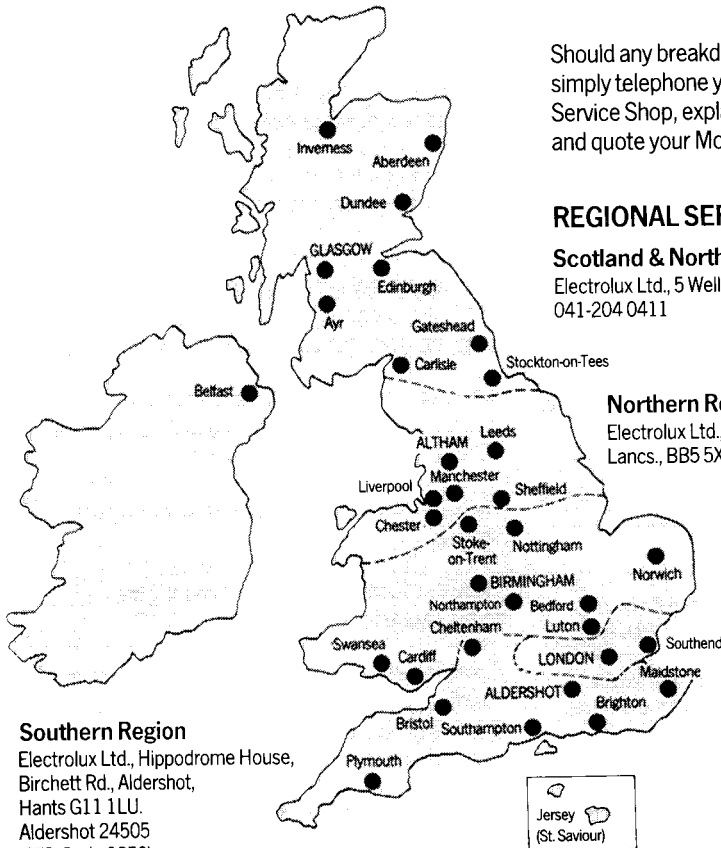

### Southern Region

Electrolux Ltd., Hippodrome House,  
Birchett Rd., Aldershot,  
Hants G11 1LU.  
Aldershot 24505  
(STD Code 0252)

## LOCAL SERVICE SHOPS

Aberdeen 695761 (STD Code 0224)  
Ayr 262242 (STD Code 0292)  
Bedford 219000 (STD Code 0234)  
Belfast 740 296/7 (STD Code 0232)  
Brighton 694341 (STD Code 0273)  
Bristol 211876 (STD Code 0272)  
Cardiff 387444 (STD Code 0222)  
Carlisle 44568 (STD Code 0228)  
Cheltenham 584051 (STD Code 0242)  
Chester 312038 (STD Code 0244)  
Dundee 22630 (STD Code 0382)  
Edinburgh 031-229 1232  
Gateshead 4600440 (STD Code 091)  
High Wycombe 41042 (STD Code 0494)  
Inverness 223056 (STD Code 0463)

Jersey (St. Saviour) Central 22138  
(STD Code 0534)

Leeds 608511 (STD Code 0532)  
Liverpool 051-220 8014  
Luton 575966 (STD Code 0582)  
Maidstone 677727 (STD Code 0622)  
Manchester 061-798 9689  
Northampton 69222 (STD Code 0604)  
Norwich 667017 (STD Code 0603)  
Nottingham 396927 (STD Code 0602)  
Plymouth 58161 (STD Code 0752)  
Sheffield 338674 (STD Code 0742)  
Southampton 785231 (STD Code 0703)  
Southend 354313 (STD Code 0702)  
Stockton-on-Tees 674848 (STD Code 0642)  
Stoke-on-Trent 413414 (STD Code 0782)  
Swansea 51848 (STD Code 0792)

# Guarantee

**This Guarantee is offered to you as an extra benefit and does not affect your legal rights.**

Electrolux products are carefully designed, manufactured, tested and inspected and in consequence we undertake to replace or repair any part found to be defective in material or workmanship, within one year of delivery to the original purchaser, free of charge.

**ADDITIONALLY, DURING THE SUBSEQUENT FOUR YEARS, ANY DEFECTIVE PARTS WILL BE REPLACED FREE — LABOUR COSTS ONLY BEING CHARGEABLE,** provided that within 14 days of the purchase the Guarantee Registration card is completed and returned to the Company.

The Company does not accept liability for defects arising from neglect, misuse, or accident. The interior light bulb and glassware are also excluded from the guarantee and the drink cooler is covered for the first year only.

There are certain conditions which may invalidate this guarantee:

- a) It is dependent upon the appliance being correctly installed and used in accordance with the Company's instructions under normal domestic conditions within the United Kingdom or the Republic of Ireland.
- b) Service under the guarantee must be carried out by an Electrolux service representative or authorised agent.
- c) The guarantee may be invalidated by unauthorised repair or modification of the appliance.

Proof of the date of purchase will be required before service under guarantee is provided. Addresses or telephone numbers for service requests are listed opposite.

We must point out that this guarantee does not cover liability for loss of food or other contents, but would draw your attention to the insurance facilities described on the separate leaflet.

## **FREEZER/REFRIGERATOR TR915A — A LUX MODEL, MADE IN BRITAIN**

---

This appliance conforms with the requirements of EEC Directive No. 82/499 relating to radio interference.

 **Electrolux**®

ELECTROLUX LTD., LUTON, BEDS. LU4 9QQ

In accordance with its policy of progressive product design the Company reserves the right to alter specifications.

T541

© Electrolux Ltd., 10/85

Publication N°.

**820 94 19**

Printed in England by Mitchells Printers (Luton) Ltd.