

## VALVE INSTALLATION & SERVICE MANUAL

TABLE OF CONTENTS	Page
ADDITIONAL AVAILABLE SERVICE INFORMATION.....	2
INSTALLATION NOTES.....	2
MAINTENANCE.....	2
TROUBLESHOOTING.....	3
REPAIR PROCEDURES.....	4-7
CONVERSION TO EXTERNAL PILOT SUPPLY.....	7
WARRANTY.....	8

The installation, maintenance, and troubleshooting information in this Service Manual is intended primarily for use with ROSS single-element poppet and spool valves. Similar information on double valves for press controls is covered in separate service manuals available from ROSS.

This Service Manual should be a useful guide to solving the problems most likely to be encountered in a pneumatic system. Other valuable guides are the Plate Drawings, Installation Instruction Sheets included with the product, Instruction Sheets included in Service Kits. A Plate Drawing is a ROSS information sheet giving the numbers of repair parts for particular valve models. The Installation Instruction Sheet offers standard and technical specification information. An Instruction Sheet details the valve installation and service processes.

Most parts are made available in the form of service kits which contain all the parts normally required for specific service operations. A Valve Body Service Kit for a poppet valve, for example, includes the seals, poppets, springs, and gaskets required to service the valve body assembly.



## ADDITIONAL SERVICE INFORMATION AVAILABLE

For copies of technical publications or other product data, visit ROSS' website at [www.rosscontrols.com](http://www.rosscontrols.com), call ROSS or your local ROSS Distributor.



## INSTALLATION

*Pneumatic equipment should be installed only by persons trained and experienced in the installation of such equipment.*

**Air lines:** Before installing a valve in an existing system, the air lines must be blown clean of all contaminants which may be in the system. It is recommended that a 5-micron air filter be installed in the inlet line close to the valve.

**Valve Inlet:** DO NOT RESTRICT AIR SUPPLY. Any restriction of the air supply lines (for example, sharp bends or clogged filter element) will reduce the speed with which the outlet volume is pressurized, and can also cause the valve to malfunction.

**Valve Outlet(s):** For faster pressurizing and exhausting of the outlet volume, locate the valve as close as possible to the mechanism being operated. Also, any restriction in the outlet lines (for example, sharp bends or undersized lines) will reduce both pressurizing and exhausting speeds.

**Valve Exhaust(s):** DO NOT RESTRICT EXHAUST OF POPPET VALVES as this can cause the valve to malfunction. To reduce exhaust noise, use a silencer such as the ROSS Muffl-Air®.

**Electrical Conduit Port:** It is important that the electrical supply be of the correct voltage and Hertz. ROSS solenoids are rated for continuous duty at 85% to 110% of the voltage shown on the solenoid coil. Multi-rated solenoids (e.g., 110-120 volts) are rated for continuous duty at 85% to 110% of the *maximum* voltage shown. A supply voltage that does not fall within this range can lead to faulty valve action or solenoid burnout.

If electrical power is supplied by a separate transformer, it must be capable of handling the inrush current of the solenoids without significant voltage drop.

**Operating Pressures and Temperatures:** Maximum and minimum operating pressures and temperatures are specified for each type of valve. Staying within these limits contributes to longer valve life and proper operation. If you must exceed these limits, consult ROSS for advice on such service.

**Pilot Pressure:** For proper operation, pilot pressure must not fall below the minimum specified for the valve. For poppet valves, pilot pressure must be at least equal to the main supply pressure.

If a solenoid piloted valve must operate at a pressure lower than the minimum specified pilot pressure, an external pilot supply of adequate pressure must be used. Some ROSS valves automatically accept an external pilot supply, while others must be converted to such use as explained on page 7.

**Vacuum or Non-Air Service:** Many ROSS valves can be used for vacuum service or with fluids other than air. Such applications require an external pilot supply. For more information, consult ROSS for Bulletin 440 ("ROSS Valves for Vacuum Service").

**Pipe Installation:** To install pipe in valve ports, engage pipe one turn, apply pipe thread sealant (tape not recommended), and tighten pipe. This procedure will prevent sealant from entering and contaminating the valve.

## MAINTENANCE

*Pneumatic equipment should be maintained only by persons trained and experienced in the maintenance of such equipment.*

**Supply Clean Air.** Foreign material lodging in valves is a major cause of improper operation. The use of a 5-micron-rated air filter located close to the valve is strongly recommended. The filter bowl should be drained regularly, and if its location makes draining difficult, the filter should be equipped with an automatic drain.

**Check Lubricator Supply Rate.** A lubricator should put a fine oil mist into the air line in direct proportion to the rate of air flow. Excessive lubrication can cause puddling in the valve and lead to malfunctions. For most applications an oil flow rate in the lubricator of one drop per minute is adequate.

(Note that the valve does not itself require air line lubrication.) See below for information about lubricants that are compatible with the materials used in the valve and are suitable for use in compressed air systems.

**Compatible Lubricants.** Although most ROSS valves do not require air line lubrication, they may be used with lubricated air being supplied to other mechanisms. Some oils contain additives that can harm seals or other valve components and so cause the valve to malfunction. The best oils to use are those specifically compounded for air line service. These are generally petroleum base oils with oxidation inhibitors, an aniline point between 180°F (82°C) and 220°F (104°C), and an ISO 32 or lighter viscosity. See chart on next page.

**Cleaning the Valve.** If the air supplied to the valve has not been well filtered, the interior of the valve may accumulate dirt and varnish which can affect the valve's performance. Although ROSS poppet

COMPATIBLE LUBRICANTS	
Maker	Brand Name
Amoco .....	American Industrial Oil 32 Amoco Spindle Oil C, Amolite 32
Citgo .....	Pacemaker 32
Exxon .....	Spinesstic 22, Teresstic 32
Mobil.....	Velocite 10
Non-Fluid Oil .....	Air Lube 10H/NR
Shell .....	Turbo T32
Sun.....	Sunvis 11, Sunvis 722
Texaco .....	Regal R&O 32
Union.....	Union Turbine Oil

valves are very tolerant of dirty air, the valve may sometimes need cleaning. To clean the valve use any good commercial solvent or kerosene. Do not use a chlorinated solvent or abrasive materials. The former damages seals, and abrasives can do permanent damage to metal parts. Reassemble the valve with a gasket and seal kit available from ROSS. Lubricate all sliding surfaces with the grease provided in the gasket and seal kit.

**Electrical Contacts.** In the electrical circuits associated with the valve solenoids, keep all switches or relay contacts in good condition to avoid solenoid malfunctions.

**Replace Worn Components.** In most cases it is not necessary to remove the valve from its installation for servicing. However, turn off the electrical power to the valve, shut off the air supply, and exhaust the air in the system before beginning any disassembly operation. Follow appropriate lock-out/tag-out procedures.

# TROUBLESHOOTING

Troubleshooting is the process of looking at a valve's symptoms (e.g., blowing to exhaust or buzzing solenoid), and then relating these symptoms to their most likely causes. By carefully analyzing the problem, the experienced troubleshooter can quickly isolate the trouble, and take appropriate corrective steps.

To assist in the troubleshooting process, the *Troubleshooting Chart* on page 5 lists most of the common symptoms which valves exhibit, and their probable causes.

Before disassembling a valve to investigate a system malfunction, check other possible causes of the malfunction. Because malfunctions in other components can affect valve action, the valve is sometimes blamed for a problem which, in fact, lies elsewhere.

We suggest, therefore, that potential malfunctions in all system components be considered when trouble occurs. Leaky cylinder packings, poor electrical contacts, dirty filters, and air line leaks or restrictions are just a few of the things to be considered when troubleshooting a pneumatic system. Consideration of these possibilities can sometimes save an unnecessary valve disassembly job.

**Caution:** Before disassembling a valve or other pneumatic component or removing it from its installation, shut off and exhaust the entire pneumatic circuit, and verify that any electrical supply is turned off. Follow appropriate lock-out/tag-out procedures.

When the valve fails to operate properly, check for the *Symptoms* listed below in the first column. For each *Symptom*, several *Possible Causes* are listed in the second column. For each *Possible Cause*, there is a *Repair Procedure* identified by a letter in the last column. These *Repair Procedures* are detailed in the following pages.

SYMPTOMS	POSSIBLE CAUSES	REPAIR PROCEDURES
Valve Blows to Exhaust When Not Actuated	Inlet Poppet Not Sealing .....	<b>A</b>
	Damaged Seals .....	<b>B</b>
	Damaged Valve-to-Base Gasket.....	<b>D</b>
	Cylinder Leaks.....	<b>H</b>
Valve Blows to Exhaust When Actuated	Damaged Valve-to-Base Gasket.....	<b>D</b>
	Damaged Seals .....	<b>B</b>
	Damaged Spool.....	<b>F</b>
	Cylinder Leaks.....	<b>H</b>
	Inadequate Air Supply .....	<b>I</b>
Water or Oil Contamination .....	<b>R</b>	
Solenoid Fails to Actuate Valve But Manual Override	Loose Pilot Cover or Faulty Solenoid.....	<b>G</b>
Does Actuate Valve	Inadequate Voltage at Solenoid.....	<b>J</b>
Solenoid Fails to Actuate Valve and Manual Override Also Fails to Actuate Valve	Damaged Seals .....	<b>B</b>
	Varnish Deposits in Valve .....	<b>C</b>
	Inadequate Pilot Pressure .....	<b>L</b>
	Water or Oil Contamination .....	<b>R</b>
Air Flow is Normal Only in Actuated Position	Broken Return Spring.....	<b>E</b>
Solenoid Buzzes	Damaged Solenoid .....	<b>G</b>
	Inadequate Voltage at Solenoid.....	<b>J</b>
	Varnish in Direct Operated Spool Valve.....	<b>C</b>
Solenoid Burns Out	Varnish in Direct Operated Spool Valve.....	<b>C</b>
	Incorrect Voltage at Solenoid.....	<b>J</b>
Pilot Section Blows to Exhaust	Loose Pilot Cover .....	<b>G</b>
	Pilot Poppet Not Sealing.....	<b>K</b>
Poppet Chatters	Inadequate Air Supply .....	<b>I</b>
	Inadequate Pilot or Signal Pressure .....	<b>L</b>
	Damaged Silencer.....	<b>N</b>
Valve Action is Sluggish	Damaged Seals on Spool Valve .....	<b>B</b>
	Varnish in Spool Valve .....	<b>C</b>
	Inadequate Air Supply .....	<b>I</b>
	Inadequate Pilot or Signal Pressure .....	<b>L</b>
	Inadequate Lubrication .....	<b>M</b>
	Damaged Silencer .....	<b>N</b>
Water or Oil Contamination .....	<b>R</b>	
Sequence Valve Gives Erratic Timing	Damaged Piston Seal.....	<b>O</b>
	Excessive Lubrication.....	<b>M</b>
	Fluctuating Air Pressure .....	<b>P</b>
	Accumulated Water.....	<b>R</b>
	Damaged Gasket.....	<b>D</b>
Flow Control Valve Does Not Respond to Adjustment	Excessive Lubrication.....	<b>M</b>
	Incorrect Installation or Dirt in Valve .....	<b>Q</b>



# REPAIR PROCEDURES

## A MAIN INLET POPPET NOT SEALING

Foreign particles may be holding the poppet off its seat. Taking appropriate safety precautions, cycle the valve several times to see if the flow of air through the valve will flush the particles out. If not, it will be necessary to disassemble the valve. See figure 1 or 2.

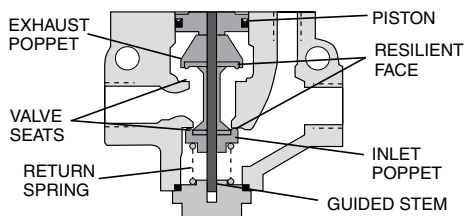

Figure 1 – Typical Inline Poppet Valve Body

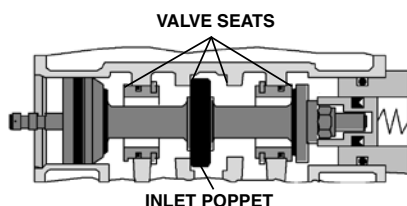

Figure 2 – Poppet Valve Body for Base Mounting

Follow appropriate lock-out/tag-out procedures. Turn off the electrical power to the valve. Shut off the air supply and exhaust the air in the system. Disassemble the valve body assembly. Inspect the inlet poppet for evidence of dirt particles or damage to the poppet. Clean or replace poppet as required. If the poppet is swollen or has deteriorated, improper lubricants or solvents may be the cause. Use only compatible lubricants; see page 2.

Also check the poppet seat(s) for dirt and damage. If there is damage to a seat, the entire valve body assembly must be replaced. If there is no damage to poppet or seat(s), inspect other parts of valve for damage. If there is no other damage, clean thoroughly, lubricate lightly, and reassemble.

## B FAULTY SEALS

The materials of which seals are made can be attacked by substances such as chlorinated hydrocarbons (trichloroethylene, for example) and some lubricating oils. This can produce swelling or shrinking of the seals and result in erratic valve action or blowing to exhaust. Swollen seals may cause poppet valves to stick in a partially open position so that the valve blows to exhaust. See Figure 1 and 2. Swollen seals on a spool valve (see Figure 3) can result in sluggish or erratic valve action, or even failure of the spool to move at all.

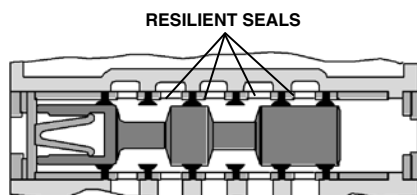

Figure 3 – Resilient Seal Aluminum Spool Valve Body for Base Mounting

Badly nicked or torn seals can produce blowing to exhaust in valves by allowing air to pass from one port area to another. Small leaks in piston poppet seals can affect the timing accuracy of sequence adaptors on inline valves, or even render the valve inoperable. Before disassembling the valve to inspect the seals, turn off the electrical power to the valve, shut off the air supply, and exhaust the air in the system. Follow appropriate lock-out/tag-out procedures. Inspect the seals and replace any that are defective. Lubricate the seals lightly and reassemble the valve. To insure long seal life, be sure to use only compatible lubricant in the pneumatic system. For a list of such lubricants, see page 2.

## C VARNISH DEPOSITS IN VALVE

See Figures 1, 3 or 4. Varnish deposits can cause a valve to act sluggishly or even prevent movement of the valve element altogether, especially after a period of inactivity. A spool valve frozen in position by varnish can cause a direct acting solenoid to buzz, and eventually lead to solenoid burnout. Varnish results from the action of oxygen on the lubricating oil, and can be aggravated by excess heat. Varnish can also come from overheated compressor oil carried over into the air lines. Properly lubricated valves do not usually suffer from varnish deposits.

To remove varnish, use a water soluble detergent or solvent such as kerosene. Do not scrape varnish off. Also, avoid chlorinated solvents (trichloroethylene, for example) and abrasive materials. The former can damage seals and poppets, and abrasives can do permanent damage to metal parts. After cleaning, lightly lubricate moving valve parts and reassemble. See compatible lubricants chart on page 2.

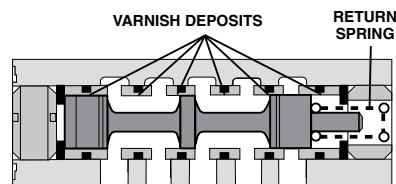

Figure 4 – Precision Finished Stainless Steel Spool Valve Body for Base Mounting

## D DAMAGED GASKETS

A broken or scored web on a valve-to-base gasket can produce air leakage between ports. This can result in unwanted pressurizing of an outlet port or blowing to exhaust. A leaking gasket on an inline valve can also produce operating problems, but is apt to be most noticeable on valves with timed sequence adaptors. If the gasket between adaptor and valve body leaks, it can bleed off the air which is slowly pressurizing the piston, so that the timing can be seriously affected. Damage to a gasket is most likely to occur during assembly. Rarely does a gasket become defective during normal operation. Do not attempt to “make do” with a damaged gasket. It will give trouble sooner or later. Replace it.

## E BROKEN RETURN SPRING

A broken return spring on a spool valve (see Figure 4) can cause the spool to remain in an actuated position, or to be only partially returned. In the latter case, several abnormal flow patterns may result depending on the valve configuration. If a spool valve has a normal flow pattern only in an actuated position, a broken return spring is the most likely cause of the trouble.

A broken return spring on an inline poppet valve is less likely to prevent closing of the inlet poppet, but should be considered as a possible cause of the valve's blowing to exhaust when not actuated, especially in a low pressure application.

# REPAIR PROCEDURES

## F DAMAGED SPOOL

If a spool is badly scored or nicked, it can allow air to pass from one port area to another. This can result in unwanted pressurizing of an outlet port or blowing to exhaust. The problem can be further aggravated by the spool's cutting the resilient seals and increasing the leakage. A damaged spool cannot be repaired, but must be replaced.

## G DAMAGED SOLENOID OPERATION

Verify that the supply voltage is correct. Refer to *Incorrect Voltage at Solenoid, Repair Procedure J*. With the electrical supply to the solenoid shut off, check for the following: (See Figure 5 or 6).

**Loose pilot cover** - A loose pilot cover can give the symptoms of a defective solenoid because it prevents full travel of the pilot valve. However, the valve can operate properly if manual actuation is used. This is because the gap is closed by the pressure of manual actuation. Tighten the cover and check for normal operation.

**Improperly installed solenoid** - If a solenoid is cocked out of line during assembly (perhaps when a replacement solenoid was installed), the pilot poppet may be held off its seat so that the valve will not function. Check solenoid for burnout (see below). If solenoid passes this check, reassemble carefully to eliminate misalignment.

**Burned out solenoid** - Check the coil for electrical continuity with an ohmmeter, and replace the solenoid if the coil is open. In spool valves with direct solenoid control, varnish deposits may prevent spool motion. This will prevent full motion of the solenoid plunger, and can cause solenoid burnout.

Solenoids operated in too high an ambient temperature are also subject to burnout. However, the most common cause of solenoid burnout is improper supply voltage. See *Incorrect Voltage at Solenoid, Repair Procedure J*. If the Solenoid coil is not burned out, examine the solenoid for the following three conditions:

## Dirt under the "T" plunger -

See Figure 7. Before removing "T" plunger, mark it and the frame so that they can be reassembled with the same orientation. Remove "T" plunger. Clean "T" plunger and frame. Before reassembling, inspect shading coil and air gap as explained below.

**Broken shading coil** - See Figure 7. Copper shading coils reduce the solenoid's tendency to buzz when operated on alternating current. If a coil is broken, the solenoid must be replaced.

**Wear that causes a loss of air gap** - There must be a small gap between the solenoid plunger and field frame when the solenoid is energized. See air gap, Figure 7. If significant wear is apparent under "T" plunger, the air gap can be lost and the solenoid must be replaced.

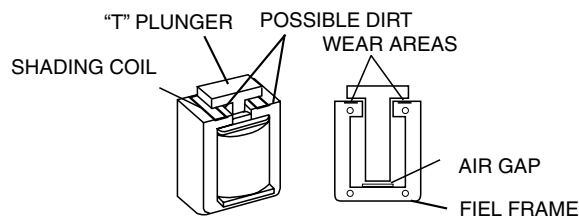

Figure 7 – Typical Pilot Solenoid

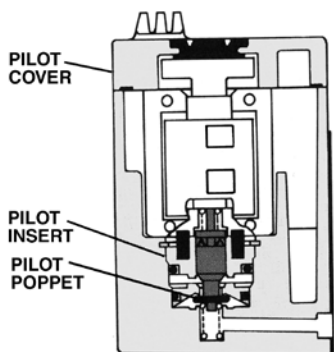

Figure 6 – Pilot Section for ANSI valves, size 2.5-20 with Plug-in Bases

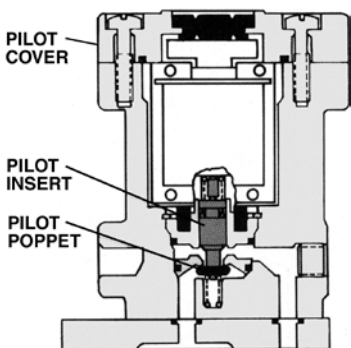

Figure 5 – Pilot Section for Inline Valves

## H CYLINDER LEAKS

See figure 8. Four-way valves sometimes blow to exhaust because of leaking packings in the work cylinder connected to the valve. Before looking for faults in the valve, check the cylinder for leaks.

*In the following steps, take appropriate safety precautions because both the valve and the cylinder will be actuated.*

1. Disconnect the air line to the end of the cylinder which is *not* under pressure. If air comes out of the open cylinder port, the cylinder packings are leaking and must be repaired. If there is no leakage, reconnect the air line.
2. Reverse the position of the valve and disconnect the other air line to the cylinder. Again check for air coming out of the cylinder port. If there is air coming out, the cylinder packings must be repaired.
3. If there is no leakage at the cylinder, reconnect the air line and proceed with troubleshooting the valve itself.

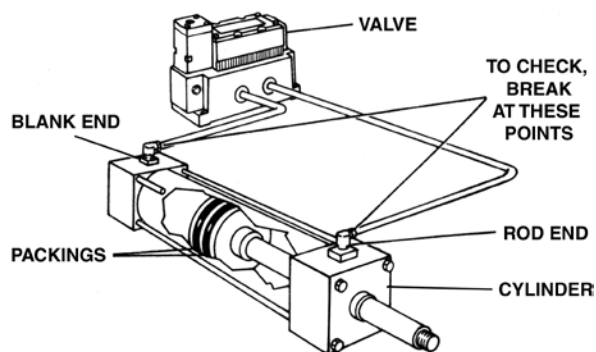

Figure 8 – Cylinder Operated by Four-Way Valve

# REPAIR PROCEDURES

## I INADEQUATE AIR SUPPLY

An inadequate air supply *volume* causes an excessive pressure drop during valve actuation. Pilot air pressure may be great enough to begin movement of the valve element, but the pressure drop resulting from the filling of the outlet volume depletes the pilot air supply. This may result in chattering or oscillating of the main valve, or may simply keep the main valve partially actuated so that it blows to exhaust.

Check the pressure drop shown on the gauge at the pressure regulator. If the pressure falls more than 10% during actuation of the valve, the air supply may be inadequate. Inspect the system for undersized supply lines, sharp bends in the piping, restrictive fittings, a clogged filter element, or a defective pressure regulator. Remember, too, that the air volume supplied can be insufficient if more pneumatic devices are connected to a circuit than the compressor is designed to serve.

## I NCORRECT VOLTAGE AT SOLENOID

ROSS solenoids are rated for continuous duty at 85% to 110% of the voltage shown on the solenoid coil. Multi-rated solenoids (e.g., 110-120 volts) are rated for continuous duty at 85% to 110% of the maximum voltage shown on the solenoid coil. A supply voltage that does not fall within this range can result in failure of the valve to shift or lead to solenoid burnout. Before checking the electrical supply, shut off and exhaust the air supply to the valve. Attach a voltmeter to the electrical supply to the solenoid. Actuate the solenoid and read the voltage during actuation. If the voltage falls below the allowable operating range, the electrical supply is inadequate, even though the supply voltage might be correct without the electrical load.

A voltage that exceeds the allowable operating range can result in solenoid burnout, or can cause impact damage resulting in a loss of air gap. See *Repair Procedure G*.

## K PILOT SECTION - DIRTY OR DAMAGED INSERT

Turn off electrical power to valve. Shut off the air supply and exhaust air in the system. Follow appropriate lock-out/tag-out procedures. Disassemble the pilot section. For pilots shown in Figure 5 or 6, remove pilot insert. Check action of insert by pressing lightly on the spring protruding from the top. Throughout its travel (about 1/32 inch) it should move easily without jerking or grabbing. If not, the insert must be replaced.

Inspect the poppet and seats for foreign particles or damage. If the poppet or upper seat is damaged, the pilot insert must be replaced. If the lower seat is damaged, the entire pilot housing must be replaced. Before installing a new insert, blow out the pilot air passages to remove any loose dirt particles. Reassemble.

For ISO valves and size 1.5 ANSI valves, see Figure 9. Disassemble pilot to remove the plunger. Inspect seals on both ends of the plunger as well as the seats against which they seal. Anything damaged should be remedied only by replacing the entire pilot assembly.

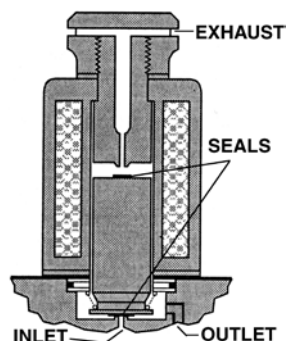

Figure 9 – Pilot Section of Valves for Size 1.5 and ISO Bases

## L INADEQUATE PILOT OR SIGNAL PRESSURE

Pilot or signal pressure below the minimum requirement can produce chattering, valve oscillation, or sluggish valve action. Check your valve specifications for minimum pilot or signal pressure requirements.

## M LUBRICATION

Some valves require lubrication to operate properly. Check the system lubricator to see that it is working as it should. Also check list of compatible lubricants on page 2.

DO NOT LUBRICATE EXCESSIVELY. Excess oil can accumulate in low points of the system and restrict the flow of air. It can also form pools which will produce a dashpot effect and slow valve action. A visible oil fog exhausting from the valve is a sure sign of excessive lubrication. Properly lubricated parts should have only a thin film on them. For most applications, an oil flow rate in the lubricator of one drop per minute is adequate.

## N UNDERSIZED OR PLUGGED SILENCER

An undersized silencer, or one that is partially plugged, restricts the exhaust flow. The resulting back pressure can cause erratic motion of poppet valve elements and/or cylinders. Remove silencer to see if valve performance is improved. Clean silencer and verify that it is of adequate size. Do not reinstall an undersized silencer. Install cleaned or larger size silencer and check valve performance again.

### CAUTION:

*Restricting the exhaust port of a poppet valve can cause the valve to malfunction. Silencers must be resistant to clogging and have a flow capacity greater than the exhaust capacity of the valve. ROSS Muffl-Air® silencers of the proper pipe size fulfill these requirements. ROSS expressly disclaims all warranties and responsibility for any unsatisfactory performance or injuries caused by the use of the wrong type, wrong size, or inadequately maintained silencer installed with a ROSS valve.*

## O DAMAGED PISTON SEAL

Piston seals may be either O-rings or the lip seal type. If worn or damaged, the seal can allow pilot or signal pressure to leak by the piston and cause erratic valve response. Operating problems are apt to be most noticeable on valves with timed sequence adaptors. A leaking piston seal can bleed off the pressurizing air and seriously affect the timing function.

## P FLUCTUATING AIR PRESSURE

If a valve with a timed sequence adaptor suffers from erratic timing, the cause can be a fluctuating supply pressure. Consistent timing requires a consistent supply pressure. If the supply pressure varies considerably, install a pressure regulator set at the system's lowest expected pressure and reset the timed sequencer to provide the desired time delay.

## Q FLOW CONTROL VALVES

Flow control valves are most often used to control the flow of air as it is exhausting from a cylinder. The flow control valve's flow pattern is indicated on the valve body by an arrow, and also by a fluid power diagram. Check to be sure the installation is correct. If it is, check for foreign material in the valve which could prevent the poppet from seating properly. See Figure 10.

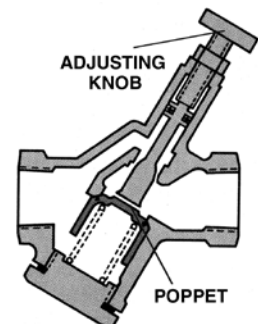

Figure 10 – Flow Control Valve

## REPAIR PROCEDURES

### WATER OR OIL CONTAMINATION

**R** Accumulations of water or oil have an especially bad effect on devices with small orifices such as timed sequence adaptors. Accumulation in such a device can change the effective size of the time orifice, or even block it completely. See Figure 11. The device must be disassembled, cleaned, lightly lubricated, and reassembled. It may be necessary to install a filter in the supply line to prevent recurrence of the problem.

Accumulations of water or oil can also occur at low points in pilot supply lines. This can result in pressure fluctuations that produce erratic timing. The best cure is to eliminate low points. Water and oil can also accumulate at low points in a valve, and hinder movement of the valve element, perhaps completely preventing its motion. See Figure 1. This is especially true of a valve operating in a subfreezing environment where accumulated water can turn to ice. It is important in such applications to ensure that the supply air is dry, and that the air line filter is drained frequently. If there is evidence of excess oil accumulation, see *Repair Procedure M*.

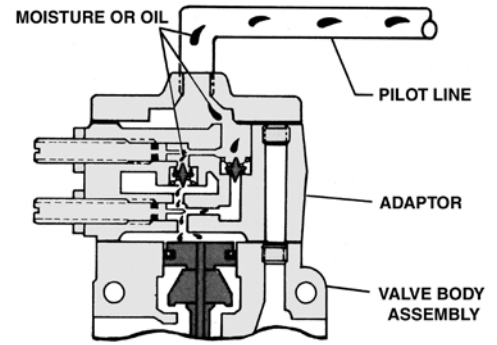

Figure 11- Sequence Adaptor

## CONVERSION TO EXTERNAL PILOT SUPPLY

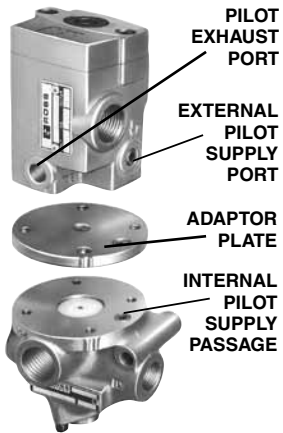

Figure 12

When a valve is converted to external pilot supply, consult ROSS for the converted valve's model number. This will allow records and drawings to be changed and prevent errors when ordering future replacements.

**INLINE POPPET VALVES:** See Figure 12.

1. Remove pilot section and adaptor plate from valve body.
2. Remove pipe plug from external pilot supply port, and reinstall the plug in the internal pilot supply passage.
3. Replace pilot section.
4. Attach 1/8" pilot supply line to external pilot supply port (X-1).
5. External pilot supply pressure must be at least equal to the main supply pressure.

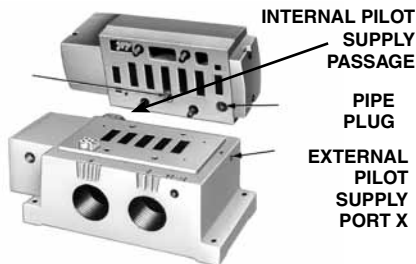

Figure 13

**ANSI SIZE 4, 10, 20 BASE MOUNTED VALVES:** See Figure 13.

1. Remove valve from base.
2. Remove pipe plug from underside of valve body.
3. Install pipe plug in internal pilot supply passage.
4. Attach 1/8" pilot supply line to external pilot supply port X in base.
5. Replace valve on base.
6. For poppet valves, external pilot supply pressure must be at least equal to the main supply pressure.

### ISO SIZES 1, 2, & 3 and ANSI SIZES 1.5 & 2.5 Base-mounted valves:

See Figures 14 and 15.

1. Remove plug from port 14 (port 12 on ANSI 1.5 & 2.5).
2. Pipe 1/8" supply line to port 14.
3. Pressure in external supply line should be greater than inlet.

If, for any reason, the external supply is lost or drops below inlet pressure, the valve will switch back to internal pilot supply.

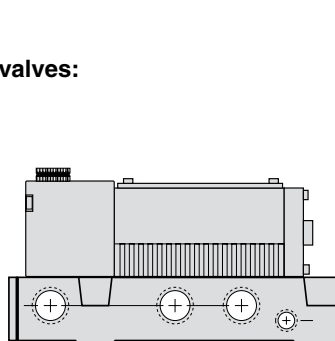

Figure 14

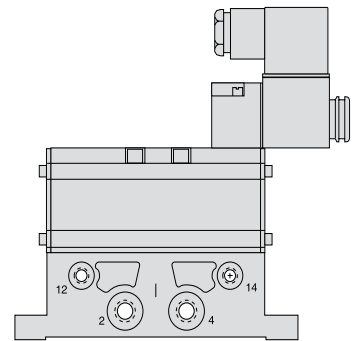
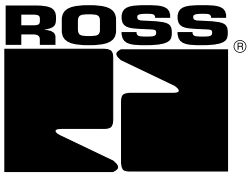

Figure 15



**GLOBAL Reach with a LOCAL Touch<sup>SM</sup>**

**ROSS CONTROLS<sup>®</sup>**

Troy, MI., U.S.A.

Telephone: + 1-248-764-1800

Fax: + 1-248-764-1850

In the United States:

Safety Department: 1-248-764-1816

Customer Service: 1-800-GET ROSS  
(438-7677)

Technical Service: 1-888-TEK-ROSS  
(835-7677)

[www.rosscontrols.com](http://www.rosscontrols.com)

**ROSS UK Ltd.**

Birmingham, United Kingdom

Telephone: + 44-121-559-4900

Fax: + 44-121-559-5309

Email: [sales@rossuk.co.uk](mailto:sales@rossuk.co.uk)

**ROSS SOUTH AMERICA Ltda.**

São Paulo, Brazil CEP 09725-020

Telephone: + 55-11-4335-2200

Fax: + 55-11-4335-3888

Email: [vendas@ross-sulamerica.com.br](mailto:vendas@ross-sulamerica.com.br)

**ROSS EUROPA<sup>®</sup> GmbH**

Langen, Germany

Telephone: + 49-6103-7597-0

Fax: + 49-6103-74694

Email: [info@rosseuropa.com](mailto:info@rosseuropa.com)

[www.rosseuropa.com](http://www.rosseuropa.com)

**ROSS ASIA<sup>®</sup> K.K.**

Kanagawa, Japan

Telephone: + 81-427-78-7251

Fax: + 81-427-78-7256

[www.rossasia.co.jp](http://www.rossasia.co.jp)

**ROSS CONTROLS (CHINA) Ltd**

Shanghai, China

Telephone: + 86-21-6915-7951

Fax: + 86-21-6915-7960

[www.rosscontrolschina.com](http://www.rosscontrolschina.com)

**ROSS CONTROLS<sup>®</sup> INDIA Pvt. Ltd.**

Chennai, India

Telephone: + 91-44-2624-9040

Fax: + 91-44-2625-8730

Email: [rossindia@airtelmail.in](mailto:rossindia@airtelmail.in)

**DIMAFLUID s.a.s.**

Saint Ouen, France

Telephone: + 33-01-4945-6565

Fax: + 33-01-4945-6530

Email: [dimafluid@dimafluid.com](mailto:dimafluid@dimafluid.com)

[www.dimafluid.com](http://www.dimafluid.com)

*Your local ROSS distributor is:*

## Warranty

All products sold by ROSS CONTROLS are warranted for a one-year period [with the exception of all Filters, Regulators and Lubricators ("FRLs") which are warranted for a period of seven years] from the date of purchase to be free of defects in material and workmanship. ROSS' obligation under this warranty is limited to repair or replacement of the product or refund of the purchase price paid solely at the discretion of ROSS and provided such product is returned to ROSS freight prepaid and upon examination by ROSS is found to be defective. This warranty becomes void in the event that product has been subject to misuse, misapplication, improper maintenance, modification or tampering.

THE WARRANTY EXPRESSED ABOVE IS IN LIEU OF AND EXCLUSIVE OF ALL OTHER WARRANTIES AND ROSS EXPRESSLY DISCLAIMS ALL OTHER WARRANTIES EITHER EXPRESSED OR IMPLIED WITH RESPECT TO MERCHANTABILITY OR FITNESS FOR A PARTICULAR PURPOSE. ROSS MAKES NO WARRANTY WITH RESPECT TO ITS PRODUCTS MEETING THE PROVISIONS OF ANY GOVERNMENTAL OCCUPATIONAL SAFETY AND/OR HEALTH LAWS OR REGULATIONS. IN NO EVENT IS ROSS LIABLE TO PURCHASER, USER, THEIR EMPLOYEES OR OTHERS FOR INCIDENTAL OR CONSEQUENTIAL DAMAGES WHICH MAY RESULT FROM A BREACH OF THE WARRANTY DESCRIBED ABOVE OR THE USE OR MISUSE OF THE PRODUCTS. NO STATEMENT OF ANY REPRESENTATIVE OR EMPLOYEE OF ROSS MAY EXTEND THE LIABILITY OF ROSS AS SET FORTH HEREIN.