

TOSHIBA

Leading Innovation >>>

FILE NO. A10-026

SERVICE MANUAL

SMART MANAGER

Model name:

BMS-SM1280HTLE

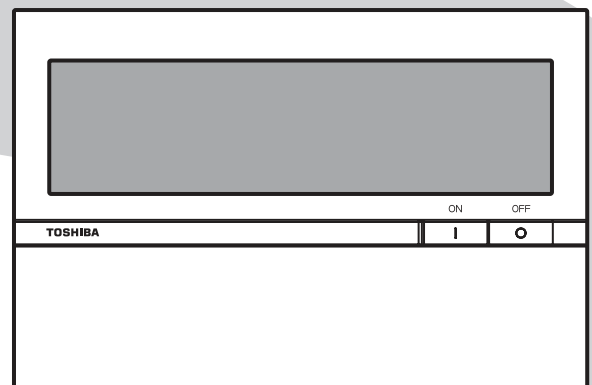



Contents

SAFETY PRECAUTIONS	3
1 PRODUCT OVERVIEW	5
2 SYSTEM CONFIGURATION	6
3 LIST OF FUNCTIONS	8
4 PRODUCT SPECIFICATION	10
5 INSTALLATION OF THE SMART MANAGER	12
6 CONNECTION OF POWER CABLES / EARTH WIRES / COMMUNICATION CABLES ...	15
7 PRODUCT CONNECTION DIAGRAM	18
8 SWITCHES FOR SETTING (Smart Manager)	20
9 MODE SETTING FOR SMART MANAGER	26
10 ZONE SETTING	27
11 CHANGING RETURN-BACK TIME / TEMPERATURE SETTINGS	28
12 TEST RUN	29
13 TROUBLESHOOTING	31
14 TEST RUN CHECK	42
15 CHECK POINTS	48
16 EXPLODED VIEWS AND PARTS LIST	52

SAFETY PRECAUTIONS



Important safety-related information is described on the product and in this Service Guide. Read the following description on labels and symbols carefully and follow their directions.

[Explanation of labels]



Label	Explanation
 DANGER	Indicates that the repair engineer and other third-party individuals in the vicinity may be exposed to immediate risk of death or serious injury if operation is not performed correctly.
 WARNING	Indicates that the repair engineer and other third-party individuals in the vicinity may be exposed to a risk of death or serious injury if operation is not performed correctly.
 CAUTION	Indicates that the repair engineer and other third-party individuals in the vicinity may be exposed to a risk of injury or that property damage (*) may result if operation is not performed correctly or from failure of product after operation.

(*): Property damage means expanded damages to assets, furniture, livestock and / or pets.



[Explanation of symbols]

Symbol	Explanation
	Indicates prohibited activity Specific prohibited actions are described in statements near the symbol.
	Indicates enforced action Specific enforced actions are described in statements near the symbol.
	Indicates caution (includes danger alert and warning) Specific content of caution is indicated in a picture or statement near the symbol.







DANGER

 Turn off breaker	Turn off breaker before performing work. Otherwise, one may receive electric shock from the high-voltage electricity, resulting in death or injury.
 Prohibition	Do not turn on the breaker when the cover of the unit is removed. Otherwise, one may receive electric shock from the high-voltage electricity, resulting in death or injury.

WARNING

 Check for ground wire	Before fault diagnosis or beginning repair work, make sure that the ground wire is connected to the ground terminal of the unit. If not, ground leakage may result in electric shock hazard.
 No alteration	Do not alter the product. Components of the unit should also not be taken apart or altered. Otherwise, it may result in fire, electric shock or injury.
 Use designated parts	Use designated parts for replacement. Using parts other than those designated may cause fire or electric shock.

 **WARNING**

 Restricted area	<p>Do not allow unauthorized personnel other than repair engineers to enter areas where fault diagnosis and repair work is conducted. Unauthorized persons may suffer injury from tools and disassembled parts.</p>
 Insulation	<p>Connect lead wires with crimping terminals and turn the closed end upwards to avoid exposure to water. Failure to perform this post-connection treatment may cause disasters, such as electricity leakage and fire, on the client's premises.</p>
 Assembly wiring caution	<p>After repair, ensure that the assembly of disassembled parts and the connection and wiring of removed wires are completed so as to restore them to their former state. Be careful not to have the internal wires caught in the cover or other closures. A defect in assembly or wire connection may cause disasters in the client premise, such as electricity leakage and fire.</p>
 Insulation check	<p>After repair, check for insulation between the charged part and non-charged metal part (ground terminal) using an insulation resistance tester (500V) and ensure at least 2MΩ resistance. If the insulation resistance value is low, it indicates the risk of disasters, such as electricity leakage and electric shock, on the client's premises.</p>
 Electric shock caution	<p>In case of performing circuit inspection while the circuit is connected to a power source (if such condition is necessary), use rubber gloves and other measures to prevent contact with the charged part. Otherwise, one will risk electric shock from contacting the charged part.</p>
 Check after repair	<p>Upon completion of repair, ensure that there are no abnormalities. Risks of fire, electric shock or injury may be prevented by inspection. Turn off the breaker before performing inspection.</p> <p>Test run the system after repair and make sure that there are no abnormalities including smoke. Risks of fire and electric shock may be prevented by inspection.</p>
 Repair and Reinstall	<p>Repair and reinstallation must be performed by qualified professional.</p>

1 PRODUCT OVERVIEW

This product is an air-conditioning control system to control and monitor the operation state of air conditioners in a building by using a computer with the mouse at a customer site. The system enables intensive management, operation control, and energy-saving operation for the air conditioners of up to 128 groups. The display and operation are available on a Web browser. This does not require dedicated software to be installed in a PC, and enables up to 4 units of PC to access simultaneously the system.

1-1. Main Functions

Monitoring / Controlling Air Conditioners

Enables users to monitor the operating status, setup status, and error status of all their air conditioners, to start and stop all their air conditioners, and change the setup details of all their air conditioners.

The air conditioners are named and categorized in a hierarchy by each floor, tenant, area, and air conditioning system. When controlling the air conditioners, they can be set in batch by each floor, tenant, or area, or they can be set individually for each air conditioning system.

The air conditioners can be controlled by linking to the locking signals and the fire alarm signals.

Scheduled Operation for Air Conditioners

Operation of all air conditioners can be scheduled. Up to 10 setups can be programmed for each day, and it is possible to prevent users from forgetting to switch off by setting a stop schedule. During scheduled operation, users can set the Power status (On / Off), Operation mode, Temperature setup, Remote control operation restricted / allowed, and Return back.

In the master schedule, users can set weekly schedules and five types of special day schedules, as well as monthly schedules for up to 12 months.

Distributing Power used by Air Conditioners

It is possible to distribute the power to be used for each air conditioner. In the billing schedule setup, it is possible to monitor the operation time period and power distribution during both working hours and non-working hours separately.

Note that power distribution requires the Energy Monitoring Relay Interface (sold separately).

Warning List

Displays all current warnings in a list. Warning history is also displayed in a list.

2 SYSTEM CONFIGURATION

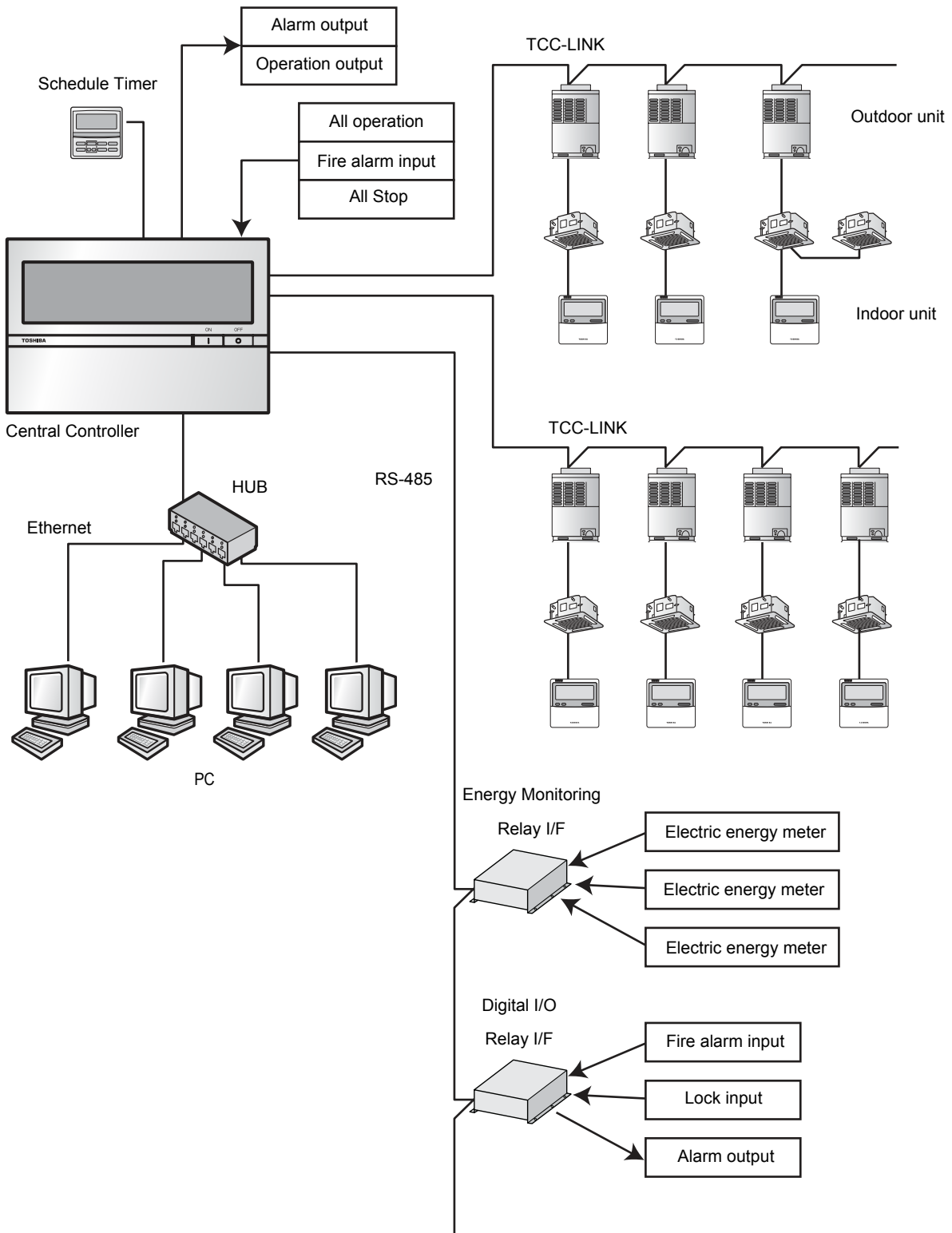

System Devices Configuration

Device Name	EXTENDED SYSTEM		
	Model	Number of Units Connected	Remarks
Indoor Unit	(TCC-LINK based model)	Max 128	Up to 64 units per line Up to 128 units in total for 2 lines
Energy Monitoring Relay Interface	BMS-IFWH5E	Max 4	Up to 8 electric energy meters per BMS-IFWH5E
Digital Input / Output Relay Interface	BMS-IFDD03E	Max 4	Up to 8 lock inputs or fire alarm inputs per BMS-IFDD03E
Central Remote Controller	TCB-SC642TLE BMS-CM1280TLE	Max10	—
Client PC	(Windows based model)	—	Up to 4 units for simultaneous access

Client PC spec	OS	Windows XP, Vista, 7
	Browser	Internet Explorer 6.0 / 7.0 / 8.0 or Firefox 2.0 / 3.0 / 3.5 / 3.6
	Display	1,024 X 768 more

2-1. Communication Specification

TCC-LINK	Topology	Bus
	Signal wire type	2-core shield wire
	Wire size, length	For 1.25mm ² (AWG16), up to 1,000 m (Total length) For 2.00mm ² (AWG14), up to 2,000 m
	Number of nodes	Up to 100 (Total of Indoor unit, Outdoor unit, Central Remote Controllers and Interfaces)
	Transmission rate	9.6kbps
	Polarity	Not exist

RS-485	Topology	Bus
	Signal wire type	2-core shield wire
	Transmission distance	Up to 500 m (Total length)
	Number of nodes	Up to 32
	Transmission rate	115.2kbps
	Polarity	Exist

Ethernet	Network interface	10BASE-T / 100BASE-TX (Auto sensing)
	Transmission rate	10 M bps (10BASE-T) 100 M bps (100BASE-TX)
	Transmission media	For 10BASE-T: Category 3 or Category 5 For 100BASE-TX: Category 5 (*)
	Straight / Crossover	Use a straight or crossover cable depending on use.
	Length	Maximum segment length: 100 m
	Connection	RJ-45 connector

(*) LAN cable: Unshielded twisted pair (UTP)

3 LIST OF FUNCTIONS

Function		Details
User account	Number of user registrations	32
	Type of user account	Administrator Power user Guest
Air conditioner category	Category structure	3 levels
Monitoring air conditioner status	Start / Stop	✓
	Operation mode	✓
	Set temperature	✓
	Fan speed	✓
	Louver	✓
	Remote control prohibition / permission	✓
	Warning	✓
	Filter sign	✓
	Room temperature	✓
	Return back	✓
	Vetilation mode	✓
Controlling air conditioner	Start / Stop	✓
	Operation mode	✓
	Set temperature	✓
	Fan speed	✓
	Louver	✓ SWING / NO SWING
	Remote control prohibition / permission	✓
	Filter sign reset	✓
	Return back	✓
	Vetilation mode	✓
Operation schedule	Number of registrations	Equivalent to the number of indoor units
	Settable period	7 days, Up to 1 week later including current date
	Number of set points per day	10 settings
	Interval of set point	1 minute
	Settable parameters	Start / Stop Operation mode Set temperature Remote control prohibition / permission Return back Vetilation mode
Master schedule	Number of registrations	32
	Settable period	Up to 12 months later including current month
	Number of set points per day	10 settings
	Interval of set point	1 minute
	Settable parameters	Start / Stop Operation mode Set temperature Remote control prohibition Return back Vetilation mode
	Weekly schedule pattern	By day schedule: 7 patterns, Monday through Sunday
	Special day schedule pattern	By special day schedule: 5 patterns
	Schedule assigning unit	By indoor unit

Function		Details
Billing schedule	Number of registrations	32
	Singularity settable period	Up to 12 months later including current month
	Number of set points per day	10 settings
	Interval of set point	1 minute
	Number of days assigned special day schedule	45 days per a special day schedule
	Settable parameters	Working hours / Non-working hours
	Number of schedule patterns	By day schedule: 7 patterns, Monday through Sunday By singularity schedule: 5 patterns
Warning display	Date / Time of warning	✓
	Warning code	✓
	Warning details	✓
Warning history display	Number of cases	1024
	Date / Time of warning	✓
	Warning code	✓
	Warning details	✓
Power distribution		✓
	Data keeping period	Daily report file: Stored for 45 days Monthly report file: Stored for 3 months Files that exceeded their keeping period are automatically deleted.
	Automatic meter reading	✓
	Manual meter reading	✓
Centigrade / Fahrenheit Temperature display switching		✓
Set temperature Unit of 1°C or 0.5°C switching		✓
Return back		✓ (Only settable on scheduler)
Control by linking to locking signal		✓
Control by linking to fire alarm signal		✓
Operation mode restriction		✓
Time setting		✓

4 PRODUCT SPECIFICATION

■ BMS-SM1280HTLE (Smart Manager)

Central Controller

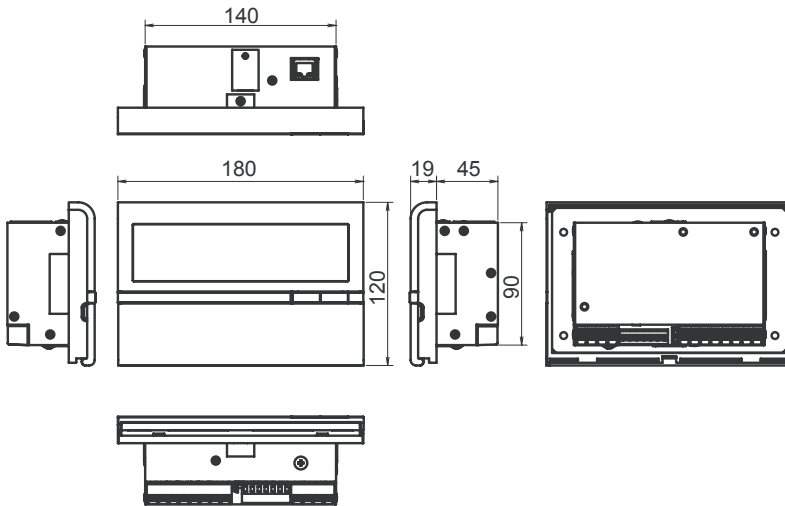

Power supply	Use the supplied power unit.
Power consumption	
Operating temperature / humidity	0 to 40 °C, 10 to 90% RH (no condensation)
Dimensions	120(H) x 180(W) x 64(D) mm
Mass	0.8 kg

Power Unit

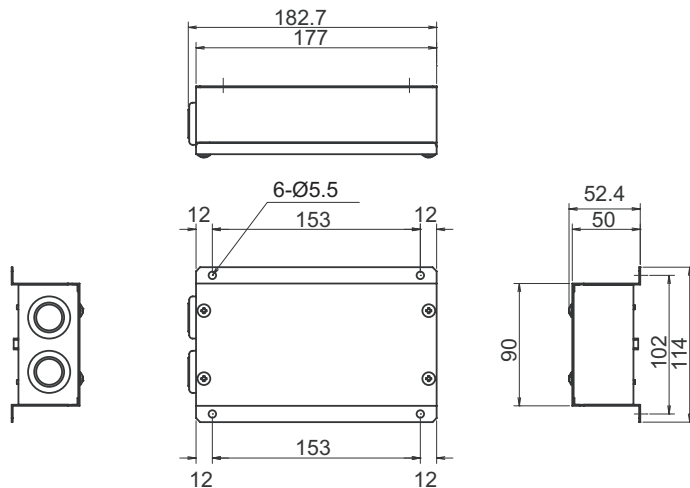

Power supply	220 - 240 VAC, 50 / 60 Hz
Power consumption	7 W
Operating temperature / humidity	0 to 40 °C, 10 to 90% RH (no condensation)
Dimensions	114(H) x 177(W) x 50(D) mm
Mass	0.9 kg

■ BMS-IFWH5E (Energy Monitoring Relay Interface)

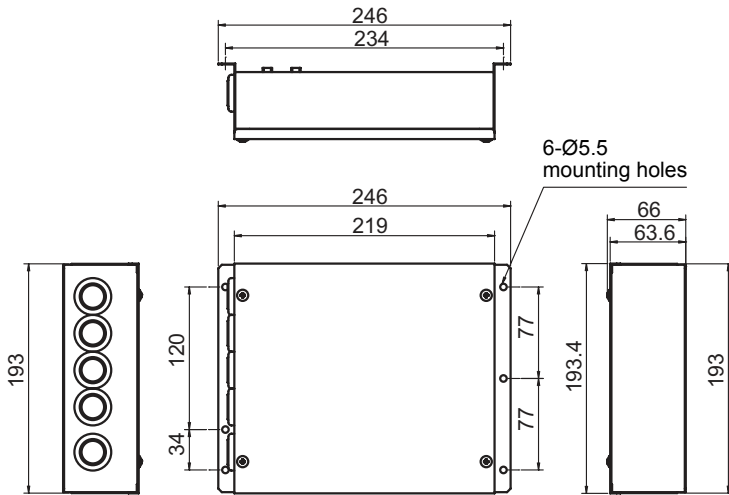

Power supply	220 - 240 V, AC 50 / 60 Hz	
Power consumption	4 W	
Operating temperature / humidity	0 to 40 °C, 10 to 90% RH	
Storage temperature	-20 to +60 °C	
Dimensions	66(H) x 193(W) x 246(D) mm	
Mass	1.35 kg	
Power meter input	Power meter input	Photo-coupler insulation
	Input points	8 points
	Input resistance	3 k ohm
	Input "ON" current	3.6 mA
	Input pulse condition	50msec or more

■ BMS-IFDD03E (Digital Input / Output Relay Interface)

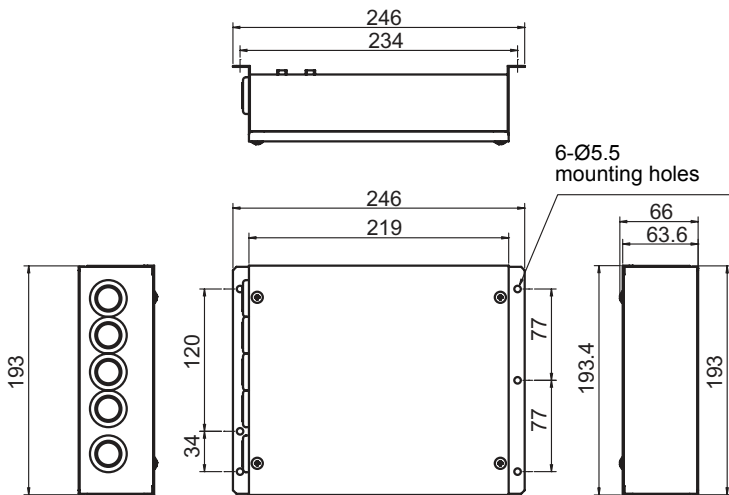

Power supply	220 - 240 V, AC 50 / 60 Hz	
Power consumption	5 W	
Operating temperature / humidity	0 to 40 °C, 10 to 90% RH	
Storage temperature	-20 to +60 °C	
Dimensions	66(H) x 193(W) x 246(D) mm	
Mass	1.35 kg	
Digital input	Input type	Photo-coupler insulation
	Input points	8 points
	Input resistance	3 k ohm
	Input "ON" current	3.6 mA
Digital output	Output type	Open collector
	Output points	4 points
	Output current	Max. 35 mA (per point)
	Output voltage	Less than DC 24V
External power supply for Input / Output	DC 12 V, 90 mA	

5 INSTALLATION OF THE SMART MANAGER

⚠ CAUTION

- Do not twist communication wires (used between indoor unit and outdoor unit and used for central control) and input/output wires with power wires or bundle them together with power wires in a metal tube. Doing so may cause malfunction.
- Install the Smart Manager away from a noise source.
- When noise is induced into the power supply of the Smart Manager, take proper measures such as attaching of a noise filter.

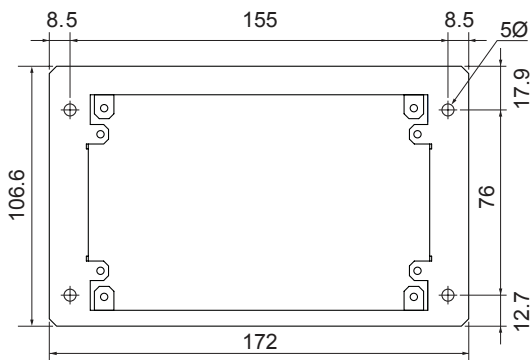
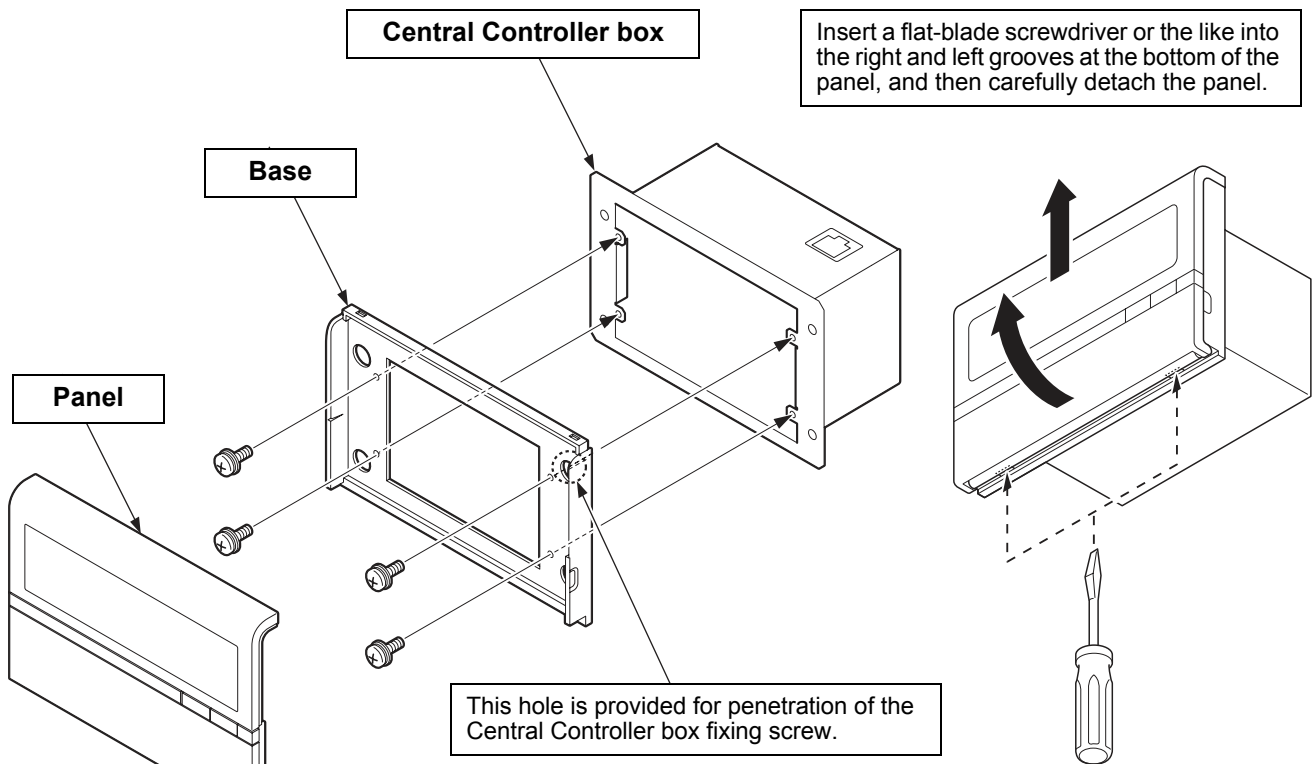

Dimensions of unit fixing holes in the wall, etc.

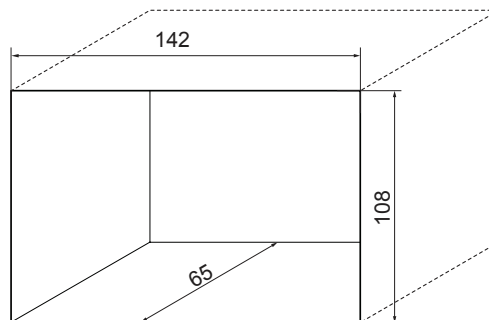

■ Power Unit Installation Method and Orientation

There are five installation methods for this power unit as shown below: surface mount and wall mounts. Use the attached screws.

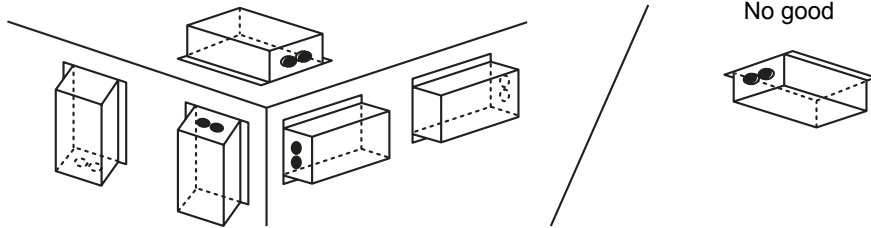

REQUIREMENT

Do not install the unit in any of the following places.

- Humid or wet place
 - Dusty place
 - Place exposed to direct sunlight
 - Place where there is a TV set or radio within one meter
 - Place exposed to rain (outdoors, under eaves, etc.)
-

■ Installation Space and Maintenance Space

A side space for connecting through cable inlets and an upper space for maintenance must be reserved before installation.

The other sides can be adjacent to surrounding objects.

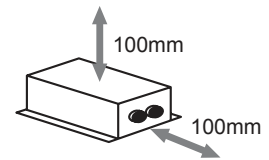

■ Combining the Central Controller and Power Unit

You can combine the central controller and power unit using the supplied brackets as follows in order to control them as one unit

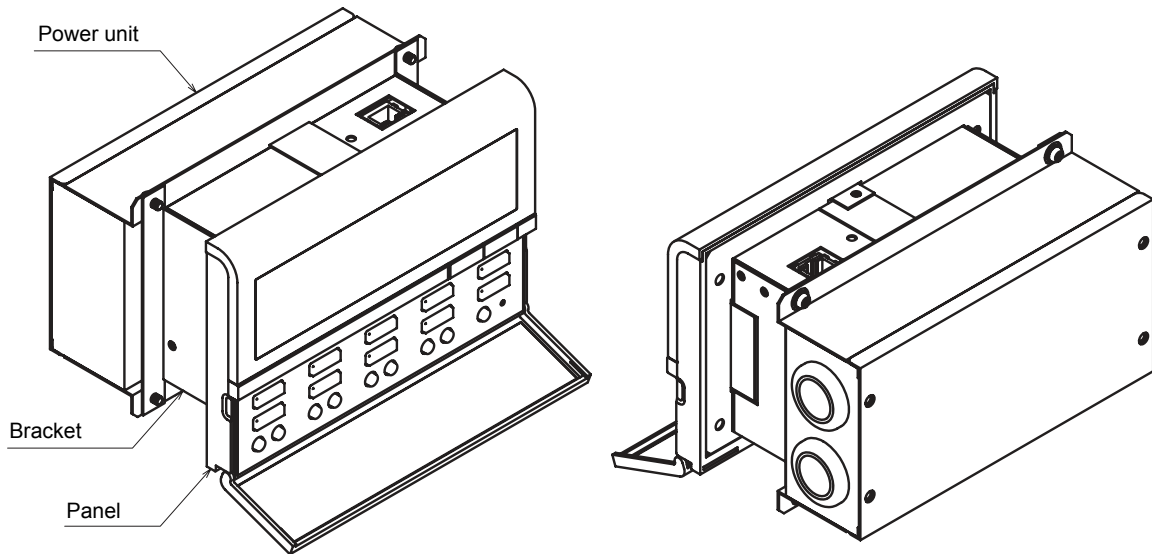

Combination method

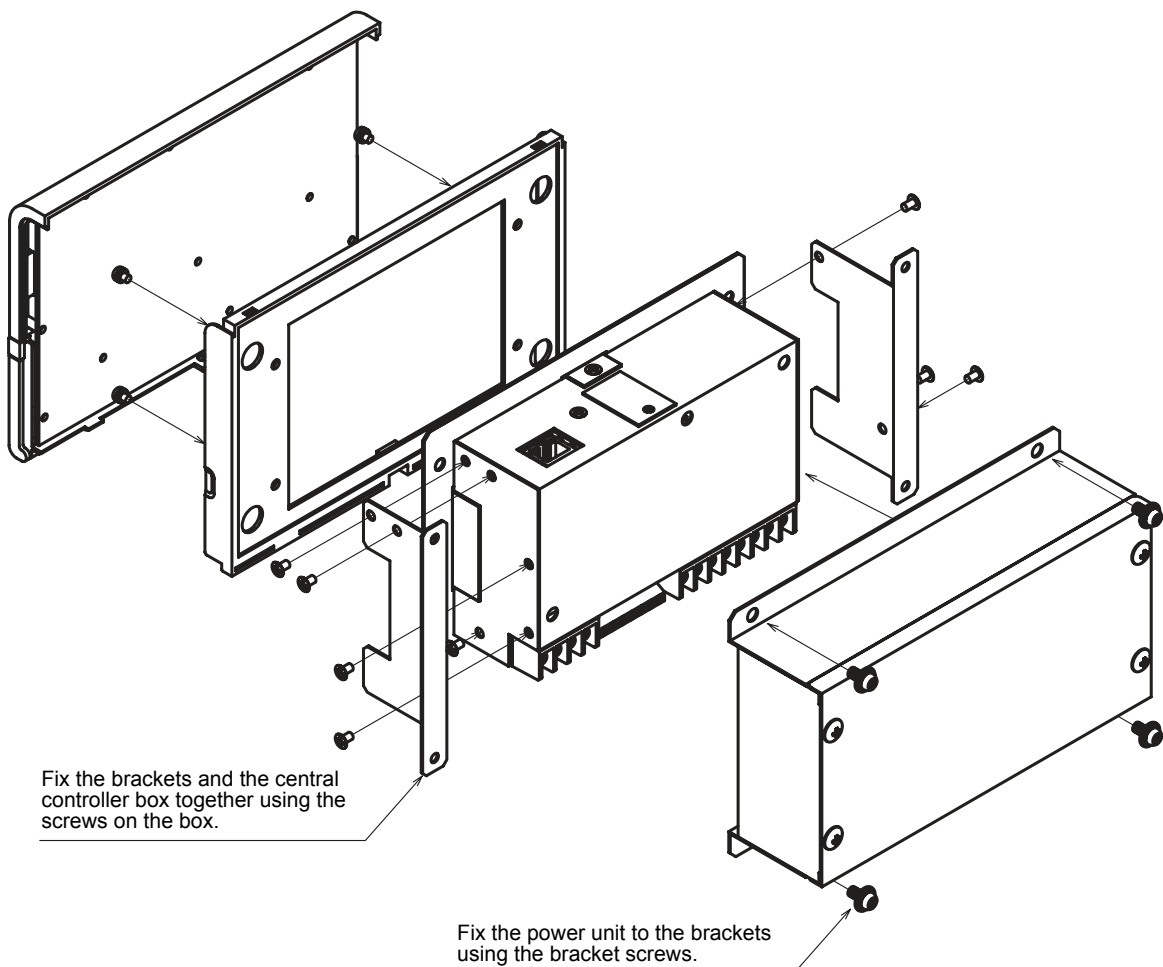

6 CONNECTION OF POWER CABLES / EARTH WIRES / COMMUNICATION CABLES

Connect power cables, communication cables, and earth wires to the specified terminals on the terminal block.

REQUIREMENT

Attach a round pressure terminal to the end of each wire except those for digital input and output.

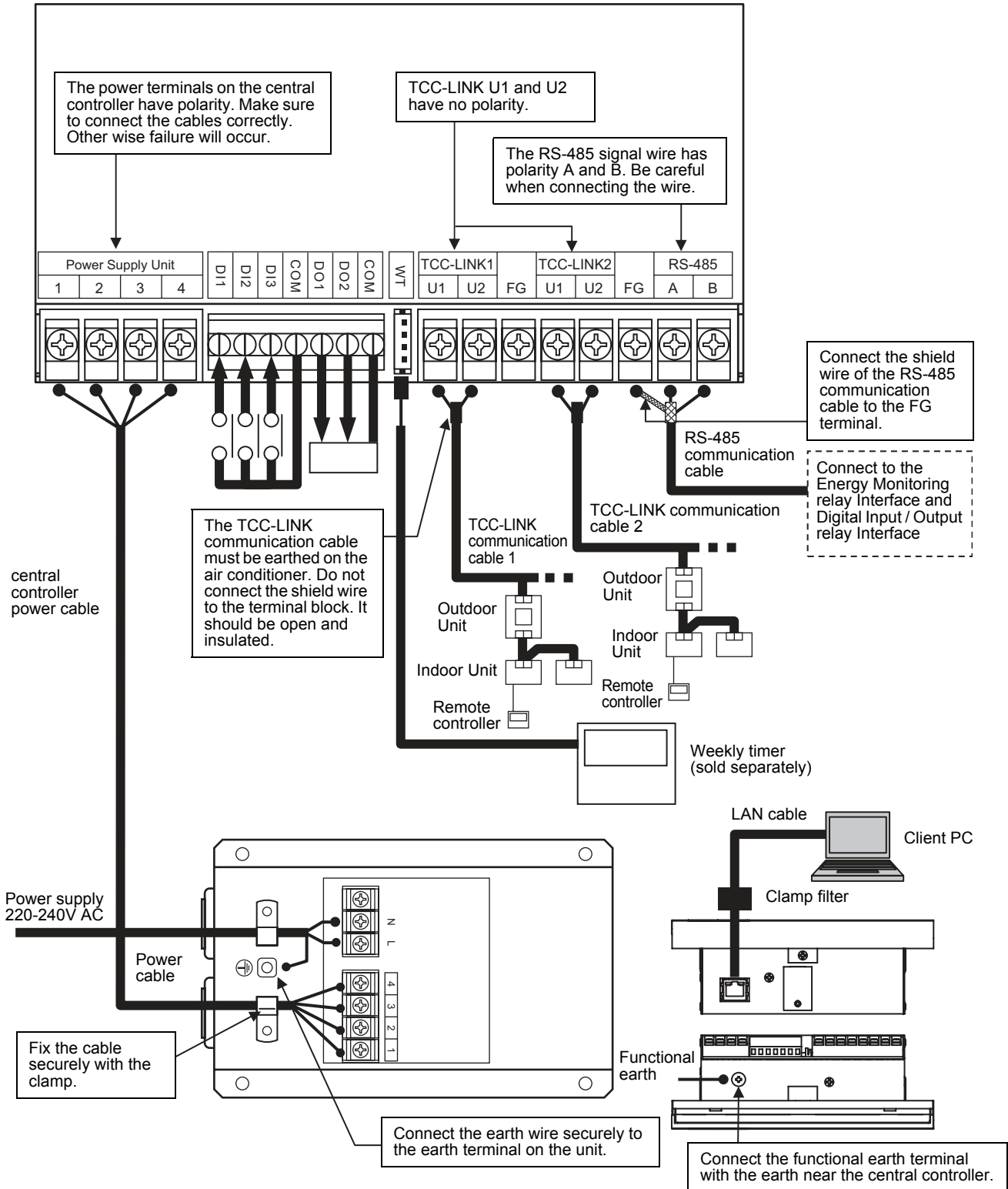

Length of stripped power cable

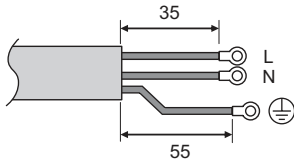

Attach a round pressure terminal to the end of each wire of the power cable, communication cable and power cable for central controller.

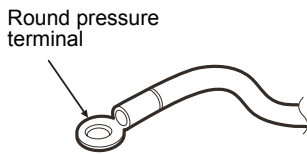

Length of stripped TCC-LINK communication cable

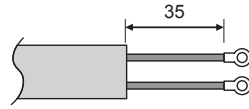

Attach the supplied clamp filter to the LAN cable.
 * Wind the LAN cable around the clamp filter as shown below when attaching the filter to the cable. After attaching the filter, fix it to the LAN cable using a supplied tie-wrap.
 * Attach the clamp filter as near the main unit as possible.

LAN cable

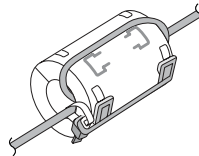

Length of stripped RS-485 communication cable

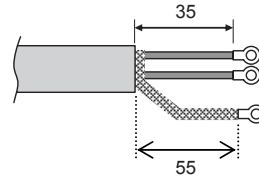

Length of stripped digital Input / Output communication wire

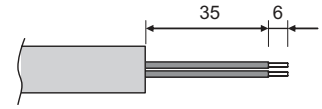

Loosen the screw with the screw driver, insert the digital input / output communication wire, then tighten the screw again to fix the wire firmly.

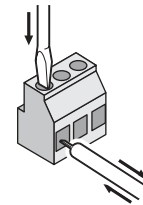

REQUIREMENT

- Disconnect the appliance from the main power supply. This appliance must be connected to the main power supply by a circuit breaker or switch with a contact separation of at least 3mm.
- Fasten the screws to the terminal with torque of 0.5Nm.

■ Connections to External Equipment

Example of connection to external equipment which is connected to digital input / output connector.

Designation	Input / Output item	Central Controller side		External equipment side	
		Input / output conditions	Terminal name	Example of circuit	Input / output conditions
DO1 (Alarm output) DO2 (Run output) DO-COM (Output common)	Status output	Allowable terminal voltage / current DC24V / 35mA	DO1 DO2 DO-COM	 Digital output	Wiring length: 100 m or less
DI1 (All stop input) DI2 (All start input) DI3 (Fire alarm input) DI-COM (Input common)	Control input	Non-voltage A contacts Pulse or static * Non voltage contacts must be compatible with minimal current. DC5V / 3mA	DI1 DI2 DI3 DI-COM	 [Pulse or static] [Pulse or static] [Static]	Pulse width: 300 ms or more Wiring length: 100 m or less

<Specifications for Wiring>

Use the following materials to connect signal lines and power lines (locally procured)

No	Line	Type / Wire size / Length
1	For TCC-LINK	2-core shield wire
		1.25mm ² , 1000m max. (total length including 2.00mm ² , 2000m max. air conditioner area)
2	For RS-485	2-core shield wire
		1.25mm ² , 500m max. (total length)
3	For power (220 - 240VAC)	H05RN-F or 245IEC57 0.75mm ² , 50m max.
4	For digital Input / Output connection	2-core wire 0.3mm ² , 100m max.
5	For power supply (Between the power unit and central controller)	4-core wire 0.75mm ² , 20m max.

7 PRODUCT CONNECTION DIAGRAM

BMS-IFWH5E • BMS-IFDD03E (Energy Monitoring Relay Interface, Digital Input / Output Relay Interface)

Installation Method and Orientation

There are five installation methods for this relay interface as shown below: surface mount and wall mounts.

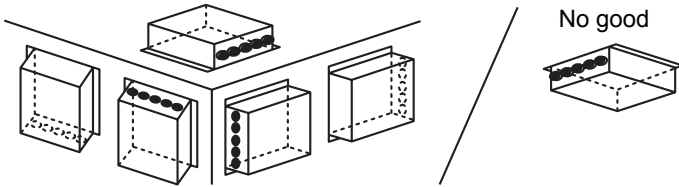

Installation Space and Maintenance Space

A side space for connecting through cable inlets and an upper space for maintenance must be reserved before installation. The other sides can be adjacent to surrounding objects.

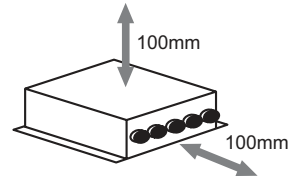

7-1. Energy Monitoring Relay Interface (BMS-IFWH5E)

Connect power cables, earth wires, and signal wires to the specified terminals on the terminal block.

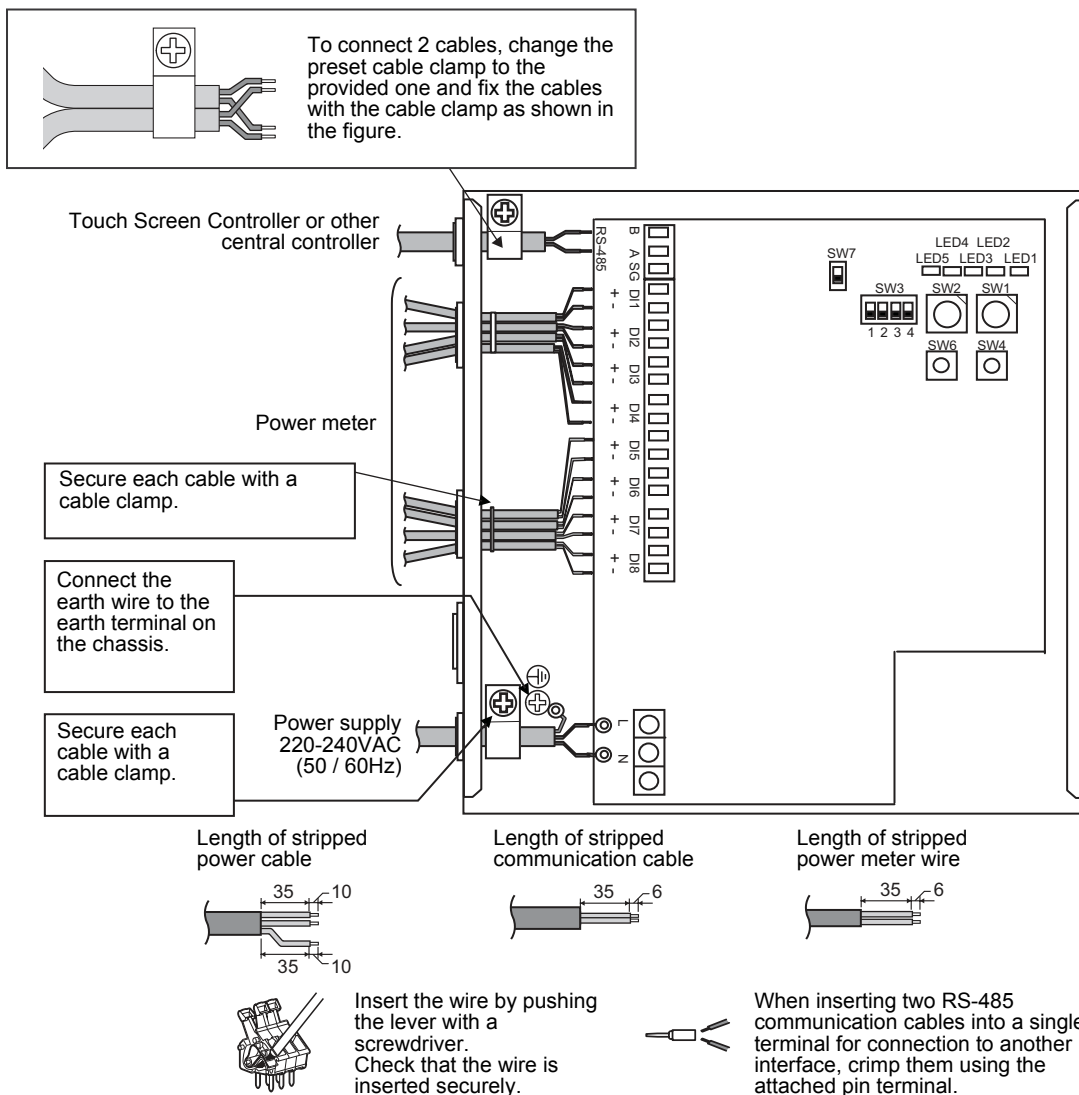

7-2. Digital Input / Output Relay Interface (BMS-IFDD03E)

Connect power cables, earth wires, and signal wires to the specified terminals on the terminal block.

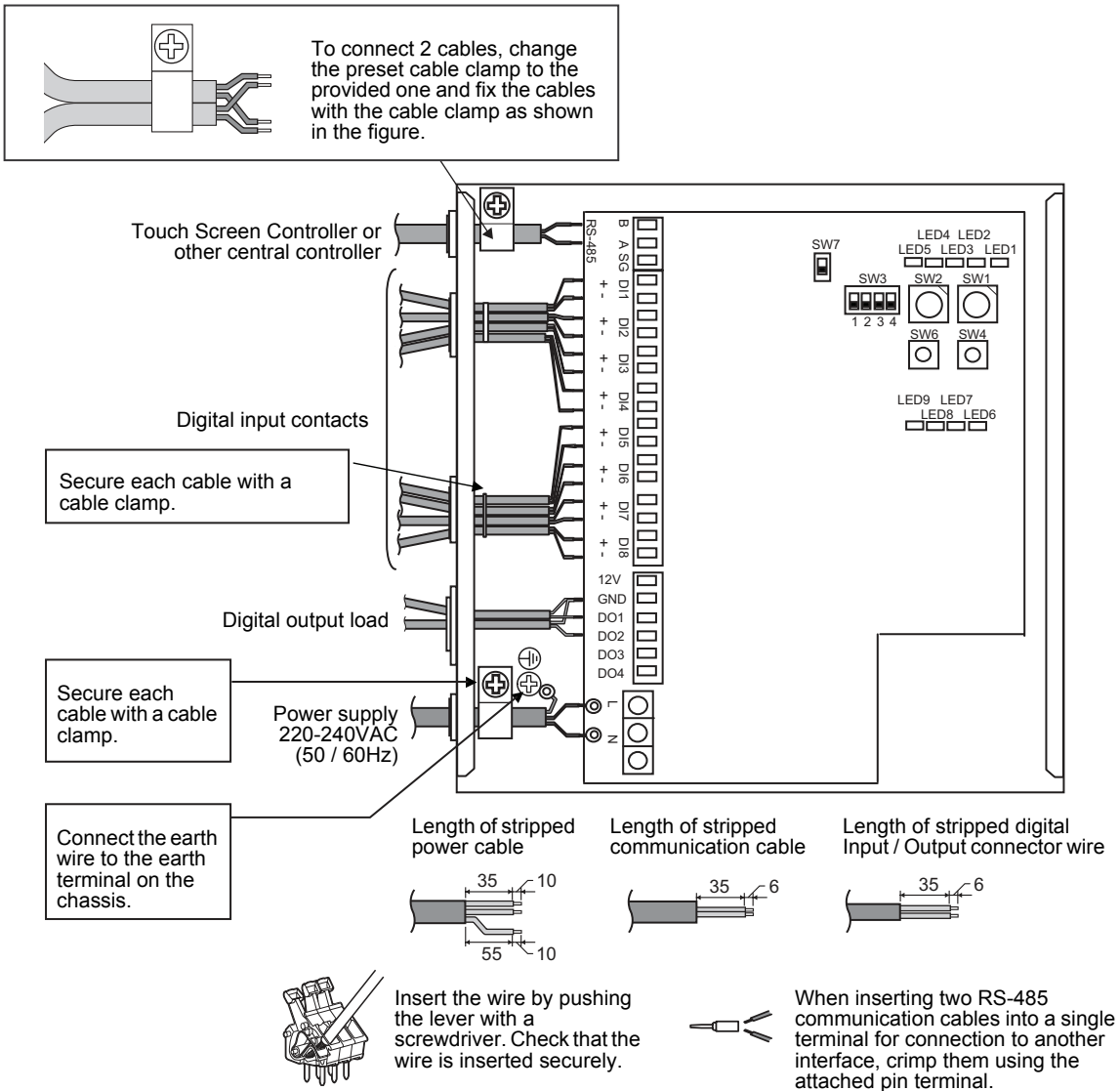

8 SWITCHES FOR SETTING (Smart Manager)

8-1. Smart Manager (BMS-SM1280HTLE)

The settings switch is installed on the rear of the Smart Manager.

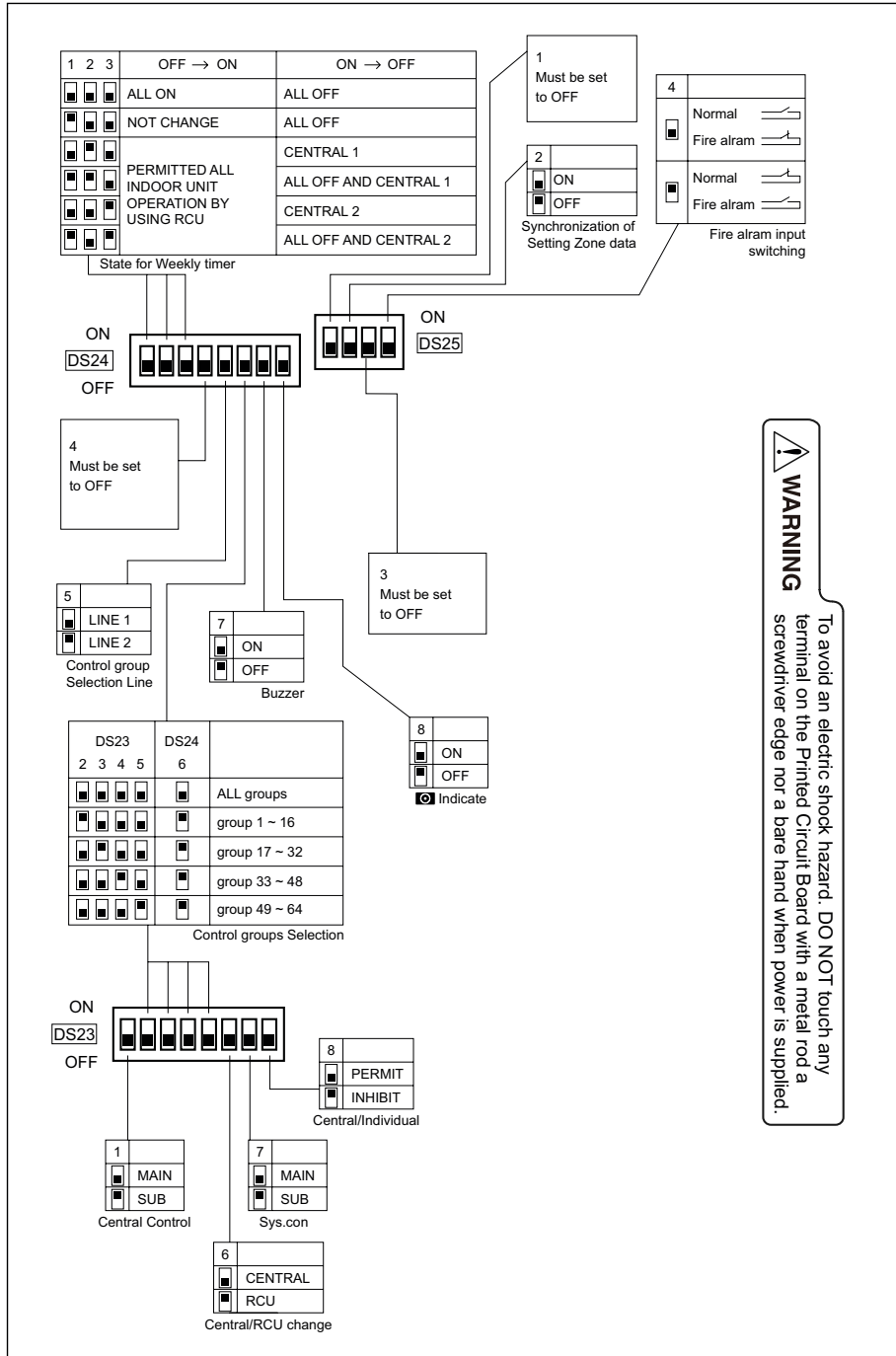

<DS23>

<1> Smart Manager main / sub selection

OFF: Main
ON: Sub

Normally, this bit is set to OFF.

When two Smart Manager units are used as a main unit and a sub unit with the same mode setting, set this bit to OFF (Main) for one unit and to ON (Sub) for the other unit.

<2> to <5> Control group selection

Control group selection	DS24-<6>	DS23
All groups	OFF	-
Group 1 ~ 16	ON	<2> ON
Group 17 ~ 32	ON	<3> ON
Group 33 ~ 48	ON	<4> ON
Group 49 ~ 64	ON	<5> ON

These bits specify a group range used in the control group selection. The Smart Manager for which control group selection is set controls only groups within the set group range.

To use the control group selection, set DS23-<2> to <5> and DS24-<5> to <6>. For details, see "9.MODE SETTING FOR SMART MANAGER".

<6> Central control / remote controller mode selection

OFF: Central control mode
ON: Remote controller mode

Central control mode: The smart manager is used as the central control device.

Remote controller mode: The smart manager is used as the remote controller.

<7> Central control Main / Sub selection

OFF: Main
ON: Sub

This setting is required when multiple Smart Manager units are used or another central control unit is used.

- (1) Set this bit to OFF when one Smart Manager unit is used.
- (2) When multiple central control units are used as a main unit and sub units, set to OFF (Main) for one unit and set to ON (Sub) for other units.

Factory setting: All OFF

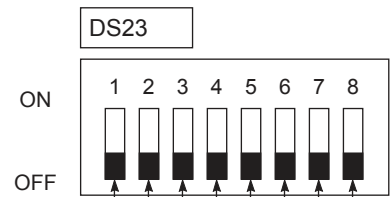

<8> Central button enable / disable

OFF: button operation is permitted

ON: button operation is inhibited

* The button is disabled in the remote controller mode regardless of this setting.

<DS24>

Factory setting: All OFF

DS24

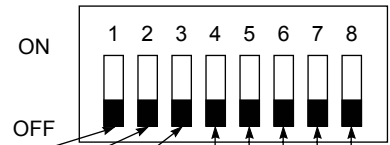

<1> to <3> Timer input switching

These bits switch operation when the weekly timer has changed.

- Use (1) and (2) only in the remote control mode.
- When the control group selection is used, “All ON,” “All OFF” and “all indoor units” mean those within the set group range.

Central controller operation		Switch No.			
		<1>	<2>	<3>	
	Timer OFF → ON	Timer ON → OFF			
(1)	All ON	All OFF	OFF	OFF	OFF
(2)	No change	All OFF	ON	OFF	OFF
(3)	All indoor units are locally controllable.	All indoor units CENTRAL 1	OFF	ON	OFF
(4)		All OFF and all indoor units to be CENTRAL 1	ON	ON	OFF
(5)		All indoor units CENTRAL 2	OFF	OFF	ON
(6)		All OFF and all indoor units to be CENTRAL 2	ON	OFF	ON

CENTRAL 1: Disables operation start / stop using the remote controller.

CENTRAL 2: Disables operation start / stop, operation mode switching, and temperature setting using the remote controller.

<4> Always OFF

Always set this bit to OFF.

<5> Control group Selection line

OFF: LINE 1

ON: LINE 2

* Set a line number for which the control group selection is used.

<6> Control group selection enable

OFF: Normal mode

ON: Control group selection

Set this bit to ON when the control group selection is used.

* To use the control group selection, set DS23-<2> to <5> and DS24-<5> to <6>. For details, see “9.MODE SETTING FOR SMART MANAGER”.

<7> Buzzer

OFF: With buzzer sound

ON: Without buzzer sound

<8>  indication

OFF: Displayed

ON: Not displayed

<DS25>

Factory setting: All OFF

<1> Always OFF

- Always set this bit to OFF.

<2> Synchronization of zone setting data

OFF: With synchronization
 ON: Without synchronization

This bit specifies whether to perform synchronous communication of zone setting data between Smart Managers.

* When this bit is set to ON (without synchronization), synchronous communication is not performed, and when zone setting is made, the data is not reflected in other Smart Managers.

<3> Always OFF

- Always set this bit to OFF.

<4> Fire alarm input switching (Set this switch to match the fire alarm input connection set in chapter 4.)

Set OPEN or CLOSE input junction pegged to fire alarm.

- OFF: Set CLOSE input junction pegged to fire alarm.

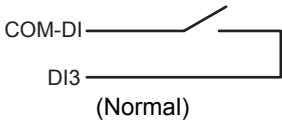

(Normal)

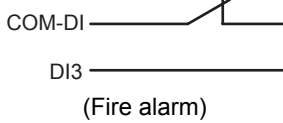

(Fire alarm)

- ON: Set OPEN input junction pegged to fire alarm.

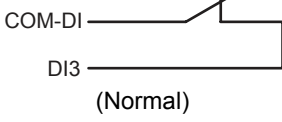

(Normal)

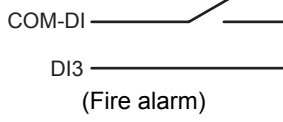

(Fire alarm)

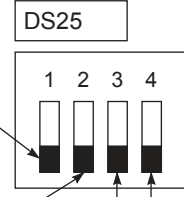

■ Termination

The termination switches for TCC-LINK are placed in the central controller box. Detach the panel when configuring termination setting.

NOTE

TCC-LINK connection is terminated on indoor units. Set SW 200 to "Open" for both TCC-LINK 1 and 2.

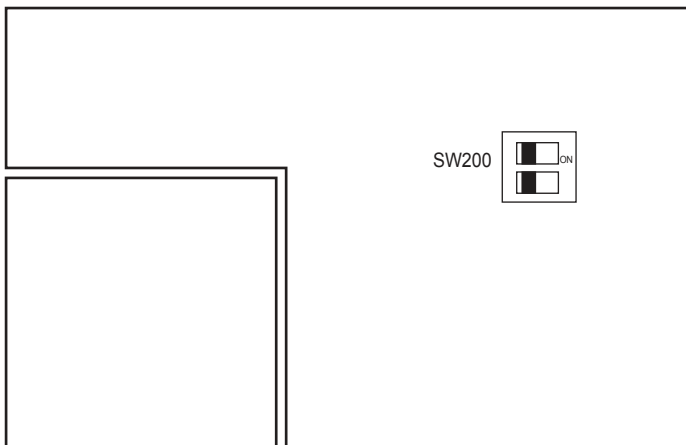

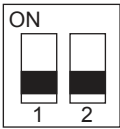
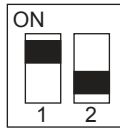
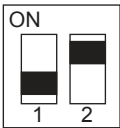
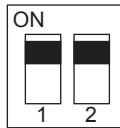

SW200	TCC-LINK termination switches			
				
	TCC-LINK1	Open	TCC-LINK1	100Ω
	TCC-LINK2	Open	TCC-LINK2	Open
				
	TCC-LINK1	Open	TCC-LINK1	100Ω
	TCC-LINK2	100Ω	TCC-LINK2	100Ω

8-2. Energy Monitoring Relay Interface (BMS-IFWH5E)

The following settings are necessary to use Energy Monitoring Relay Interfaces.

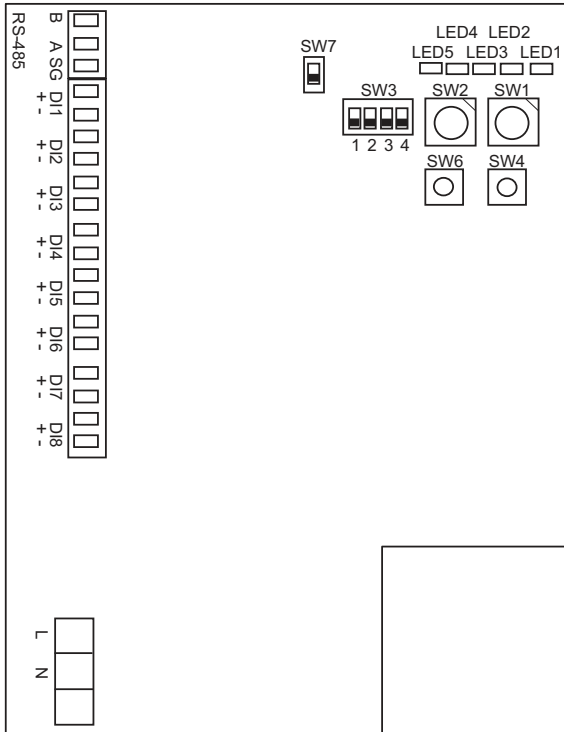
Address setting	SW1 Address set switch When two or more Energy Monitoring Relay Interfaces are used, set a different address for each unit to avoid address duplication.
RS-485 terminator resistor setting	Set SW7 as "120 ohm" on a Energy Monitoring Relay Interface with address SW1=1, and "Open" on the other interfaces.



SW1	Address set switch	
	1-8	Address
	0, 9-F	Not used
SW2	Operating mode set switch (0 usually)	
SW3	Test switch (all OFF usually)	
SW4	Test switch	
SW6	Reset switch	
SW7	RS-485 terminator resistor select switch	
		
	120 ohm	Open
LED1	Power indicator	
LED2	RS-485 communication status indicator	
LED3	Not used	
LED4	Test indicator	
LED5	Test indicator	

8-3. Digital Input / Output Relay Interface (BMS-IFDD03E)

The following settings are necessary to use Digital Input / Output Relay Interfaces.

Address setting	SW1 Address set switch When two or more Digital Input / Output Relay Interfaces are used, set a different address for each unit to avoid address duplication.
RS-485 terminator resistor setting	Set SW7 as "120 ohm" on a Digital Input / Output Relay Interface with address SW1=1, when the Digital Input / Output Relay Interface is used in a system without Energy Monitoring Relay Interface. Set SW7 as "Open" on the other interfaces.

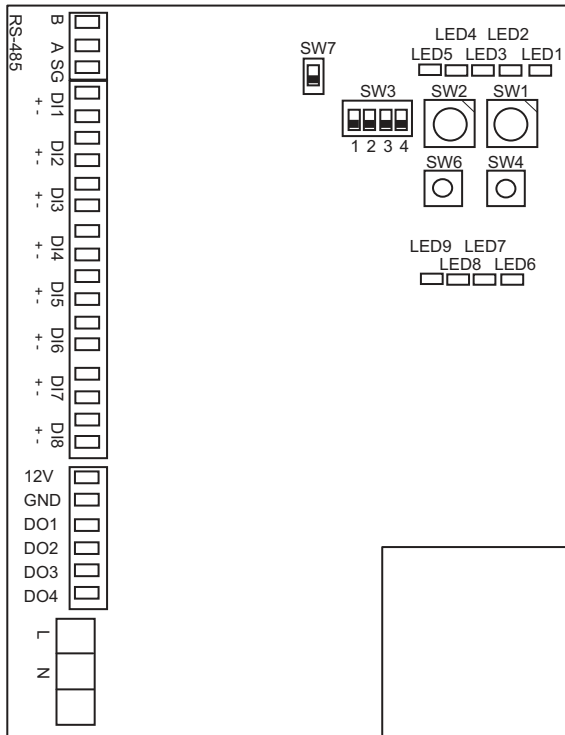

SW1	Address set switch	
	1-8	Address
	0, 9-F	Not used
SW2	Operating mode set switch (0 usually)	
SW3	Test switch (all OFF usually)	
SW4	Test switch	
SW6	Reset switch	
SW7	RS-485 terminator resistor select switch	
	120 ohm	Open
LED1	Power indicator	
LED2	RS-485 communication status indicator	
LED3	Not used	
LED4	Test indicator	
LED5	Test indicator	
LED6-LED9	Digital output indicator	

9 MODE SETTING FOR SMART MANAGER

■ Operation mode

You can switch the functional mode of the smart manager between the central control mode and remote control mode. The mode is switched with the dip switch DS23-<6>.

OFF side: Central control mode

This Smart Manager is used as a central control unit.

Settings with the remote controller are inhibited by the setting of the Smart Manager.

ON side: Remote control mode

This Smart Manager is used as a remote controller.

Settings with the Smart Manager are inhibited by the setting of another central control unit.

■ Control group selection

An arbitrary range of a line and 16 groups (1 to 16, 17 to 32, 33 to 48, and 49 to 64) can be selectively set.

		DS23				DS24	
		<2>	<3>	<4>	<5>	<5>	<6>
All groups		OFF	OFF	OFF	OFF	OFF	OFF
LINE 1	Group 1 to 16	ON	OFF	OFF	OFF	OFF	ON
	Group 17 to 32	OFF	ON	OFF	OFF	OFF	ON
	Group 33 to 48	OFF	OFF	ON	OFF	OFF	ON
	Group 49 to 64	OFF	OFF	OFF	ON	OFF	ON
LINE 2	Group 1 to 16	ON	OFF	OFF	OFF	ON	ON
	Group 17 to 32	OFF	ON	OFF	OFF	ON	ON
	Group 33 to 48	OFF	OFF	ON	OFF	ON	ON
	Group 49 to 64	OFF	OFF	OFF	ON	ON	ON
Example: When setting LINE 1 (group 1 to 32) in the control group selection		ON	ON	OFF	OFF	OFF	ON

* When the control group selection is not used ("ALL group"), all groups and zones on LINE 1 and LINE 2 can be controlled.

* When the control group selection is used, only groups and zones in the set group range can be controlled.

- When the control group selection is used, groups and zones outside this range are not displayed and cannot be operated.

- **ALL** means the entire set group range.

- Zones can be registered and operated only within the set group range. (No groups outside the range can be registered or operated.)

- The group control mode is available only for one line.

* Multiple group ranges can be specified by the control group setting.

(Example) When groups 33 to 48 and groups 49 to 64 are specified at the same time, a group range (groups 33 to 64) is set by the control group setting.

10 ZONE SETTING



■ What is zone?

- A zone is a control unit consisting of a combination of any indoor units and the settings of indoor units in a zone can be configured collectively.
- You can make up to 64 zones pairing any of up to 64 groups in a line. By using lines 1 and 2, you can set up to 128 zones in total.
- As factory setting, each zone contains one group to make zone numbers equal to group numbers.



■ Setting zones

Register groups in a zone or cancel them.

(1) Change the mode to the zone setting mode.







- Press the  button,  button, and ZONE  button simultaneously for at least 4 seconds.
(The displayed zone number flashes and the Smart Manager enters the zone setting mode. Indicates CODE No. "E1".)

(2) Select the zone to be set.



- Select the zone number to be set with the ZONE  or  button, and then press the  button to fix the selection.
(When the selection has been fixed, the selected zone number lights.)
- When selection of zone has been fixed, the [] marks of the group numbers registered in the zone light up.

(3) Change registration of groups in a zone.

Register groups in a zone.

1. Select the group number to be set with the GROUP  or  button. Pressing the SET TEMP.  or  button skips the group number by +16 or by -16.
2. Press the  button.
The registered group number stops flashing and lights still.
3. Pressing the  button restores the state before the  button is pressed.
4. To continue registration of groups, repeat this procedure from the 1.

NOTE

No zone data has been stored at this time. If the ZONE  or  button is pressed before the registration change is fixed, the set content for registration change is discarded.

(4) Fix the registration change.

Press the  button. The set content for registration change is stored in the memory.

- * After the memory write operation has been completed, the Smart Manager exits the zone setting mode.

NOTE

- Any indoor unit cannot be registered on to two or more zones at the same time.
If you register a group of a zone on to another zone, the group is eliminated from the old zone.
 - Zone registration of a group cannot be cancelled. To exclude a registered group from a zone, register it on another zone.
-

11 CHANGING RETURN-BACK TIME / TEMPERATURE SETTINGS

■ What is return-back?

When the return-back function is activated, the temperature setting exceeding the return-back temperature will automatically be adjusted to the return-back temperature after a certain period of time to prevent extremely high / low temperature setting.

■ Setting the return-back time and temperature

Follow the procedure below to set the return-back time and temperature.

NOTE









Do not change the data of CODE No. 0A and the following item codes to prevent the remote controller from malfunctioning.

Two sets of return-back settings, Return-back 1 and 2, can be stored. Select Return-back 1 or 2 using  buttons when activating the return-back function.

CODE No.	Item	Data	
		Factory setting	Setting range
01	Activate / deactivate the return-back function	001 (Enabled)	000 (Disabled), 001 (Enabled)
02	Time setting of Return-back 1, for heating	030 (30 minutes)	1 to 60 minutes (in units of 1 minute)
03	Time setting of Return-back 1, for cooling	030 (30 minutes)	1 to 60 minutes (in units of 1 minute)
04	Temperature setting of Return-back 1, for heating	018 (18°C)	18 to 29°C (in units of 1°C)
05	Temperature setting of Return-back 1, for cooling	028 (28°C)	18 to 29°C (in units of 1°C)
06	Time setting of Return-back 2, for heating	030 (30 minutes)	1 to 60 minutes (in units of 1 minute)
07	Time setting of Return-back 2, for cooling	030 (30 minutes)	1 to 60 minutes (in units of 1 minute)
08	Temperature setting of Return-back 2, for heating	018 (18°C)	18 to 29°C (in units of 1°C)
09	Temperature setting of Return-back 2, for cooling	028 (28°C)	18 to 29°C (in units of 1°C)

Changing settings

The following shows an example of changing the time (factory setting) in the case of return-back 1 heating from 30 minutes to 45 minutes.

- (1) Change the mode to the CODE No. setting change mode.
Press the , , and ZONE  buttons simultaneously for at least 4 seconds.
(**SETTING** and CODE No. flash.)
- (2) Change the CODE No.
Press SET TEMP   buttons to set the CODE No. to "02".
(CODE No. "02" and time setting "30" flash.)
- (3) Change the time setting.
Press GROUP   buttons to set the time setting to "045".
- (4) Press the  button to determine the data. **SETTING** and CODE No. stop flashing and stay lit.
To continuously change other settings, repeat steps (2) to (4) above.
- (5) Determine the change.
Press the  button to write the updated data in the memory of the remote controller.
* When the data has completely been written in the memory, the CODE No. setting change mode is exited.

NOTE

Setting adjustment is cancelled without determining the change.

12 TEST RUN

Start the system to perform operation check by following the procedure below.

12-1. Preparation

No.	Item	Details	Procedure	
1	Preparation	Discuss with a customer to determine details of the following. <ul style="list-style-type: none"> • Select devices, and create a system diagram • Determine the addresses of an air conditioner and interfaces, and create an address management table • Set an IP address of Smart Manager • Create a setting file with the Setting File Creation Software 	Refer to the Owner's manual of the Setting File Creation Software.	
2	Device installation	Install Smart Manager and the interfaces.	Refer to "INSTALLATION OF THE SMART MANAGER" (page 12) in this manual. For further details, refer to the Installation manual of each device.	
3	Wiring	Connect the power cables, ground wires, and signal wires to Smart Manager and the interfaces.	Refer to "CONNECTION OF POWER CABLES / EARTH WIRES / COMMUNICATION CABLES" (page 15) in this manual. For further details, refer to the Installation manual of each device.	
4	Device setting	Set the air conditioner and the interfaces.	Set the address of the devices according to the address management table. Refer to "SWITCHES FOR SETTING (Smart Manager)" (page 20) in this manual. For further details, refer to the Installation manual of each device.	
		1) Air conditioner		Address setting
		2) Energy Monitoring Relay Interface		Address setting, RS-485 termination resistance setting
		3) Digital Input / Output Relay Interface	Address setting, RS-485 termination resistance setting	
5	Setting file upload	1) Upload the setting file.	For further details, refer to the setting file creation software.	
		2) After the change, reset Smart Manager.		
6	Client PC setting	Configure network and browser setting of the client PCs.	For further details, refer to the Network Configuration Guide of Smart Manager.	

12-2. Operation Check

Complete the test run of air conditioners before operation check.

No.	Item	Details	Procedure	
1	Start-up check	<ul style="list-style-type: none"> • Turn on the all air conditioners. • Turn on the all interfaces. • Turn on Smart Manager and check that the LCD displays all the air conditioners where the intensive management addresses are set. • Check that the interfaces LEDs properly illuminate or blink. 	For further details, refer to the Installation manual of each device.	
		Energy Monitoring Relay I/F		LED1 (Red) illuminates
				LED2 (Green) blinking
		Digital Input / Output Relay I/F		LED1 (Red) illuminates
		LED2 (Green) blinking		
2	Check for electric energy meter input	Check for electric energy meter pulse input		
3	Check for fire alarm input	Check for fire alarm signals input; Check for electric lock signals input		
4	Logon	From the client PC browser, access Smart Manager to display the logon screen.	For further details, refer to the Network Configuration Guide of Smart Manager.	
		In the logon screen, enter a user name and a password to log on. Factory setting: user name (TCC), password (TCC) (*) Logon in not available immediately after the start-up. Wait for approx. 5 minutes and enter the information to log on.	For further details, refer to the Owner's manual of the Smart Manager.	
5	Check at the time of air conditioner setting change	Start or stop the air conditioner from the client PC to check that the air conditioner operates accordingly.		
6	Check air conditioner status display	Change the operation status or setting status using the air conditioner remote controller to check that the client PC monitor screen properly displays the status.		

13 TROUBLESHOOTING

About the check codes

If there is a problem with the air handling unit or if the controller detects anything unusual with the system, a check code is displayed in the warning list on the computer screen or the LCD of the controller.

Check code	Description	Action
C06	Communication error with the air handling unit	Check the communication status of TCC-Link.
S06	Communication error with BMS-IFWH	Check the communication status of RS-485.
S07	Communication error with BMS-IFDD	Check the communication status of RS-485.
S15	File access error	Check the SD card.
S17	File load error	Check the main file.
S21	Mail transmission error	Check the settings of the e-mail.
S22	Internal communication error	Check the internal wiring and the main file.
Code other than the above	Error detected in the air handling unit	Check the air handling unit.

13-1. Trouble with Connection

13-1-1. Logon screen is not displayed.

No.	Cause	Solution
1	The controller is not turned on.	Turn on the controller.
2	The HUB is not turned on.	Turn on the HUB.
3	The LAN cable is not connected.	Check that the LAN cable is inserted into the controller and PC and connect them.
4	The same subnet is not set for the IP address of the controller and that of the PC.	Check the controller and PC IP addresses, and set the same subnet for them. For further details, refer to "Network Configuration Guide".
5	The browser software is set to use the proxy server.	In setting the browser proxy server, add the controller IP address to the address that does not use the proxy server. For further details, refer to "Network Configuration Guide".
6	The URL entered in the browser software is incorrect.	Check that the URL is http://the controller's IP address/index.html , and correctly enter this URL.
7	The controller has frozen.	Turn off the controller and wait about 30 seconds. Turn it on again, then access from the browser software after 5 minutes.
8	The controller does not work.	1. Check that the controller and HUB are turned on. 2. Check that the LAN cable is connected. 3. Check that the LED of the controller LAN connector illuminates. * If the LED does not illuminate, the controller is defective. It needs to be repaired.
9	The PC is malfunctioning.	1. Restart the PC and check again if it works. 2. Replace the PC and check again if it works.
10	The LAN cable is defective.	Replace the LAN cable and check again if it works.

13-1-2. Unable to log on.

No.	Cause	Solution
1	The controller is being initialized during the startup process. The dialog message, "No response from the server." or "The system is being prepared.." appears.	Close the browser once. Wait for 5 minutes and log on again.
2	The user name or password are incorrect. The dialog message, "You failed in login." appears.	Enter correct user name and password.
3	No user name is entered. The dialog message, "Please input user name." appears.	Enter a correct user name.
4	No password is entered. The dialog message, "Please input password." appears.	Enter a correct password.
5	The same user name has already logged on. The dialog message, "The same user is logged already." appears.	1. Use another user name to log on. 2. If the user logged on can be identified, ask the user to log off. 3. If neither of the above two is unavailable, turn off the controller to log off all the users.
6	The controller has frozen. The dialog message "The system is being prepared." appears. Even if the browser is once closed and after 5 minutes the controller is logged on, the dialog message "The system is being prepared." still appears.	Turn off the controller and wait about 30 seconds. Turn it on again, then log on after 5 minutes.
7	Invalid data was written to the file in the controller. • The dialog message "The system is being prepared." appears. Even if the browser is once closed and after 5 minutes the controller is logged on, the dialog message "The system is being prepared." still appears. • Even if the controller is once turned off and logged on again after 5 minutes.	Initialize the setting file with the setting file creation software. For further details, refer to the owner's manual of the setting file creation software.

13-2. Trouble with Web Screen

13-2-1. Takes long time to display.

No.	Cause	Solution
1	The network is busy.	Connection via an intra-company LAN may slow the Web screen display due to a busy network. Use the system during off-peak hours of network use, or use a dedicated network to connect a PC with the controller. If a 10 BASE switching HUB is used, replace it with a 100 BASE switching HUB.
2	PC performance has degraded.	If some application programs are operating other than the browser, the PC performance may degrade. Close the operating applications other than the browser, and check if the PC performance improves.
3	Trouble due to the browser.	The supported browsers are Internet Explorer 6.0, 7.0 and 8.0 and Firefox 2.0, 3.0, 3.5 and 3.6. If a browser other than these browsers is used, the contents may not be displayed properly. Use one of the supported browsers to see the contents.
4	Other users are also accessing the controller.	If other users are performing schedule setting or other operation, the display switching may slow down. Wait for a while, and access to the controller again.
5	The controller is writing a file.	The controller regularly writes a file for electricity distribution. The display may slow down during the writing process.

13-2-2. Improperly returns to the logon screen.

No.	Cause	Solution
1	The controller performance has degraded.	If the controller is accessed from a browser while the controller internal processing is in progress, the controller performance degrades. To prioritize controller internal processing (writing a file or giving instruction to an air conditioner), the system once stops the access from the browser. Log on again.

13-2-3. After logon, the dialog message “No response from the server.” appears.

13-2-4. After logon, the dialog message “The system is stopping.” appears.

13-2-5. After logon, the dialog message “The system is being prepared.” appears.

No.	Cause	Solution
1	The controller is not turned on.	Turn on the controller. Wait for 5 minutes and logon again.
2	The HUB is not turned on.	Turn on the HUB and log on again.
3	The LAN cable is not connected.	Check that the LAN cable is inserted into the controller and PC and connect them. After that, Log on again.
4	The controller has frozen.	Turn off the controller and wait about 30 seconds. Turn it on again, then access from the browser software after 5 minutes.
5	The controller does not work.	Check that the controller and HUB are turned on. Check that the LAN cable is connected. Check that the LED of the controller LAN connector is lit. * If the LED of the LAN connector does not illuminate, the controller is defective. It needs to be repaired.
6	The PC is malfunctioning.	Restart the PC and check again if it works. Replace the PC and check again if it works.
7	The LAN cable is defective.	Replace the LAN cable and check again if it works.

13-2-6. After logon, the dialog message “Login has been disabled.” appears.

No.	Cause	Solution
1	The user account has been deleted.	The message appears if the user account used for the logon is deleted. Log on with another user account.

13-2-7. The buttons or other elements are not displayed.

No.	Cause	Solution
1	Trouble due to browsers.	The supported browsers are Internet Explorer 6.0, 7.0 and 8.0 and Firefox 2.0, 3.0, 3.5 and 3.6. If a browser other than these browsers is used, the contents may not be displayed properly. Use one of the supported browsers to see the contents.
2	The controller performance has degraded.	<p>If the controller is accessed from a browser while the controller internal processing is in progress, the controller performance degrades. To prioritize controller internal processing (writing a file or giving instruction to an air conditioner), the system once stops the access from the browser. At this time, the browser may fail to display buttons or other elements.</p> <p>The missing GUI elements can be displayed by refreshing the browser window. For Internet Explorer, click [View] and then [Refresh]. For Firefox, click [View] and then [Reload].</p>
3	The network is busy.	<p>Connection via an intra-company LAN may slow screen display due to a busy network, possibly causing the display failure of those elements. Use the system during off-peak hours of network use, or use a dedicated network to connect a PC with the controller.</p> <p>If a 10 BASE switching HUB is used, replace it with a 100 BASE switching HUB.</p> <p>The missing GUI elements can be displayed by refreshing the browser window. For Internet Explorer, click [View] and then [Refresh]. For Firefox, click [View] and then [Reload].</p>
4	The PC performance has degraded.	If some application programs are operating other than the browser, the PC performance may degrade. Close the applications in operation other than the browser, and check if the PC performance improves.

13-2-8. The screen does not switch or takes long time to switch.

No.	Cause	Solution
1	Operating schedule is displayed and set.	If many operating schedules are displayed and set, switching the screen takes long time after the operating schedules are set. After selecting a zone of the air conditioner, perform “Change Operating Schedule” to reduce the number of operating schedules performed at a time, and then display and set the schedules.
2	The alarm history list is displayed.	If many alarms are to be displayed, the display takes long time. Wait for the list to be displayed without performing any operation.

13-2-9. The name of floor, tenant, area, or air conditioner is not properly displayed.

No.	Cause	Solution
1	The inputs in the setting file are incorrect.	Correct the name in the setting file, and upload the file to the controller.

13-2-10. The operation state does not match that displayed on the remote controller.

No.	Cause	Solution
1	The inputs in the setting file are incorrect.	Check if the address set in the setting file matches that in the air conditioner. To show the address set in the air conditioner, press the [UNIT] button on the remote controller. Correct the address set in the air conditioner or the setting file.
2	The wiring for TCC-LINK is not properly installed.	The controller has two TCC-LINK connecting terminals: TCC-LINK1 and TCC-LINK2. Check if the setting in the setting file matches the actual connection. If not, correct so that they match.

13-2-11. Unable to log off.

No.	Cause	Solution
1	The communication with the controller is unavailable.	The dialog message "No response from the server" appears, and closing the dialog displays the message "Internet Explorer cannot display the webpage." or "The connection has timed out." Take the same action as for the case, "13-2-3. After logon, the dialog message "No response from the server." appears."

13-2-12. The browser does not close.

No.	Cause	Solution
1	The communication with the controller is unavailable.	The browser takes some time to close. Wait for a while for the browser to close.
2	The PC is malfunctioning.	1. The browser takes some time to close. Wait for a while for the browser to close. 2. If it does not close after a while, start the task manager to exit the browser.

13-2-13. The floor, tenant, area, or air conditioner is not displayed in the proper order.

No.	Cause	Solution
1	The inputs in the setting file are incorrect.	The floor, tenant, and area are displayed in the order of the floor number, tenant number, and area number set in the setting file. Change the display order as needed. The air conditioners are displayed in the order of outdoor system number and indoor units number set in the air conditioner. Change the display order as needed. If the order cannot be changed, change the air conditioner number in the setting file.

13-2-14. The date or time is not properly displayed.

No.	Cause	Solution
1	The controller has been off for long hours.	In [Clock and calendar setting] from the option in the menu, set the current time.

13-2-15. The value of air temperature is incorrect.

No.	Cause	Solution
1	The air temperature displays the intake temperature corrected for the room temperature control of the air conditioner.	The displayed and actual temperatures differ because correction amount varies depending on an operation mode (cooling or heating).

13-3. Other Troubles

13-3-1. The date or time change is not applied.

No.	Cause	Solution
1	The internal processing of the controller is prioritized.	The internal processing of the controller may be given priority over a setting operation from the browser. Try to change the date or time again.

13-3-2. The air conditioners do not operate as scheduled.

No.	Cause	Solution
1	The controller is not turned on.	Turn on the controller.
2	The scheduled operation is not correctly set.	Check that the operating schedule of each air conditioner is correctly set. Check that the air conditioner for which the operating schedule is set matches the air conditioner to be operated. Check that the date and time setting is correct. * Correct the settings above if necessary, and set operating schedule so that the air conditioner operates after 3 minutes and see if it operates as scheduled.
3	The controller has frozen.	Turn off the controller, then turn it on again after 30 seconds.

13-3-3. The operation is unavailable with the remote controller.

No.	Cause	Solution
1	The remote controller control is set to not allowed.	Check with the controller LCD that the control is set to "CENTRAL". To enable the operation with the remote controller, change the setting in the controller to "No indication".

13-3-4. The air conditioner does not operate according to the operation setting, such as operate or stop, made from the browser. The settings go back to the previous state after a while.

No.	Cause	Solution
1	The system does not properly communicate with the air conditioner.	Check if the communication error with the air conditioner is detected.
2	The indoor unit is set as the extension unit.	Change the setting in the setting file so that air conditioner is set as the main unit.
3	The operation setting falls outside the range of the temperature or operation mode set in the air conditioner.	If the setting falls outside the set temperature range, the temperature will be set to the upper or lower limit value of the set temperature range. If the setting falls outside the range of the set operation mode, the air conditioner does not operate in the mode set. It operates in the mode before the change.

13-3-5. The details of schedule set is not displayed.

No.	Cause	Solution
1	The schedule setting operation failed.	The setting made without selecting a schedule point in the schedule setting window does not apply to the schedule point. Select a schedule point and perform setting. In the schedule setting window, if the setting is finished with [OK] without clicking [Set], the scheduled data set is not finalized. Click [Set] and then [OK] to finish.

13-3-6. Clicking [OK] or [Cancel] does not close the window or takes some time for the window to close.

No.	Cause	Solution
1	Operating schedule is displayed and set.	If many operating schedules are displayed and set, closing the operating schedule window takes some time after [OK] or [Cancel] is clicked. Wait for the window to close without performing any operation.
2	The controller performance has degraded.	If the controller is accessed from a browser while the controller internal processing is in progress, the controller performance degrades. Because the controller internal processing (writing a file or giving an instruction to the air conditioner) is prioritized, closing the window takes some time. Wait for the window to close without performing any operation.

13-3-7. The User added in User Account is not applied.

No.	Cause	Solution
1	The controller is turned off within 20 minutes after the user account is added.	Setting information such as user account is written to the file in the controller at 20-minute intervals. Leave the controller on for 20 minutes or longer after setting a user account.

13-3-8. The set temperature is automatically changed.

No.	Cause	Solution
1	The set temperature or Return Back is set in the scheduled operation setting.	Check if the setting details of the operating schedule is correct.
2	The set temperature is changed from the remote controller or other controllers.	Check if the remote controller or other controller is wrongly used for operation.

13-3-9. The cooling or heating operation does not work with “The operation is being prepared” displayed on the remote controller.

No.	Cause	Solution
1	The operating mode restriction is set.	In [Operation mode restriction] from the option in the menu, check if [HEAT,FAN] or [COOL,DRY,FAN] is selected.

13-3-10. The calculation result of electricity amount output by the Monthly Report Creation Software is not correct.

No.	Cause	Solution
1	The controller cannot receive the air conditioner operating information due to a communication error.	Check if the communication error with the air conditioner is detected.
2	The controller cannot acquire the correct electricity amount.	Check if the communication error with the air conditioner is detected. Check if pulse is input to the electricity amount meter interface from the electricity amount meter.
3	The room takes more time to warm up or cool down than other rooms.	This electricity distribution system calculates electricity amount to be distributed based on the necessary capacity of the indoor units for controlling temperature. This can distribute larger electricity amount to the room that is not easily warmed up or cooled down than to other rooms in the same operation time period.

13-3-11. No daily report file is found.

No.	Cause	Solution
1	The controller was not turned on at the time of meter-reading.	If the controller is off at the time of meter-reading, the daily report file of the day is not created. The accumulated operation hours and electricity amount are added up to the daily report file of the next day, so the values in the daily reports will be correctly summed up.

13-3-12. An alarm other than C06, S06, or S07 is displayed on the air-conditioning management system window.

No.	Cause	Solution
1	The air conditioner has detected the alarm	Check the inspection indication on the remote controller or the multi outdoor unit board. Identify defective parts or check the parts and wiring by following the service guide of each air conditioner.

13-4. Trouble at Installation

13-4-1. The IP address cannot be changed.

No.	Cause	Solution
1	The address setting method was not changed to manual setting before changing the IP address.	To change the IP address, the address setting method must be set to manual setting "1". Change the method to manual setting. When the method is changed to manual setting, the IP address that was manually set at the last time is shown. If the IP address has never been changed, it is shown as all "0", so the proper IP address needs to be set.
2	The IP address is being set.	After the address is changed, the controller restarts for the address setting. Wait for 5 minutes after changing the address, and check that the address has been changed.

13-4-2. IP address is unknown.

No.	Cause	Solution
1	The address setting method is set to automatic acquisition, and the DHCP server is not connected.	After connecting to the DHCP server, check with the controller IP address display for the address. Change the address setting method to manual setting, and set the IP address.
2	The IP address has been changed.	Check with the controller IP address display for the address is detected. Set the address setting method to manual setting, and set the IP address.

13-4-3. The controller LCD displays incorrect details.

No.	Cause	Solution
1	None of the air conditioner is connected or turned on.	When communication is unavailable with any air conditioner, any of the following is displayed: "LINE" and "ALL", "ZONE", or "GROUP". Check if the air conditioner is turned on or communication wiring is properly installed.

13-4-4. Lock input does not stop the air conditioner.

No.	Cause	Solution
1	Communication error with the digital input / output relay interface.	1.Check if communication error with the digital input / output relay interface is detected.
		2.Check if communication error with the air conditioner is detected.
2	Communication error with the air conditioner.	1.Check if communication error with the digital input / output relay interface is detected.
		2.Check if communication error with the air conditioner is detected.
3	The inputs in the setting file are incorrect.	Check if the lock input name is correctly set in the [Indoor unit group definition] sheet of the setting file.

13-4-5. Fire alarm input does not stop the air conditioner.

No.	Cause	Solution
1	Communication error with the digital input / output relay interface.	1.Check if communication error with the digital input / output relay interface is detected.
		2.Check if communication error with the air conditioner is detected.
2	Communication error with the air conditioner.	1.Check if communication error with the digital input / output relay interface is detected.
		2.Check if communication error with the air conditioner is detected.
3	The inputs in the setting file are incorrect.	Check if the lock input name is correctly set in the [Indoor unit group definition] sheet of the setting file.

13-4-6. Clearing fire alarm input does not enable air conditioner operation.

No.	Cause	Solution
1	Communication error with the digital input / output relay interface.	1.Check if communication error with the digital input / output relay interface is detected.
		2.Check if communication error with the air conditioner is detected.
2	Communication error with the air conditioner.	1.Check if communication error with the digital input / output relay interface is detected.
		2.Check if communication error with the air conditioner is detected.
3	The controller is not turned on.	Turn on the controller.

* If any of the above does not solve the problem, turn off the indoor unit, and turn it on again.

13-4-7. Communication error with the digital input / output relay interface is displayed.

No.	Cause	Solution
1	The digital input / output relay interface is not turned on.	Check if the "POWER" LED of the digital input / output relay interface illuminates.
2	The RS-485 communication wiring is not connected or disconnected.	Check the conduction of the communication wiring.
3	The RS-485 communication wiring is incorrect or connected with wrong polarity.	Check the terminal block connected.
4	The terminal resistance is not connected.	Check the value of the terminal resistance with a tester.
5	The wiring length is too long.	Change it to the specified wiring length.
6	The communication circuit of the digital input / output relay interface failed.	Replace with the normal digital input / output relay interface and check that the communication is available.
7	The communication circuit of the controller failed.	Replace with the normal controller and check that the communication is available.

No.	Cause	Solution
8	Noise is superposed on the communication wiring.	Check the waveform between RS-485 communication wiring A and B. If noise is superposed, identify the noise source and remove it.
9	The communication cable in use is not the specified one. (Wire diameter is smaller)	Change it to the specified communication cable.

The address switch setting of the digital input / output relay interface does not match that in the setting file.

No.	Cause	Solution
3	The RS-485 wiring is defective between the digital input / output relay interface and the controller.	1. Check the address switch setting of the digital input / output relay interface and the setting in the setting file. 2. Check if the RS-485 LED (Green) of the digital input / output relay interface blinks.

13-4-8. Communication error with the energy monitoring relay interface is displayed.

No.	Cause	Solution
1	The energy monitoring relay interface is not turned on.	Check if the "POWER" LED of the energy monitoring relay interface illuminates.
2	The address switch setting of the energy monitoring relay interface does not match that in the setting file.	1. Check the address switch setting of the energy monitoring relay interface and the setting in the setting file. 2. Check if the RS-485 LED (Green) of the energy monitoring relay interface blinks.

13-5. Questions about Functions

No.	Questions	Answer
1	What is the procedure to create a setting file?	Please read the Owner's manual of the Setting File Creation Software.
2	How many air conditioners can be connected?	Up to 128 units of air conditioners can be connected. Note that up to 64 units can be connected per TCC-LINK line.
3	How many air conditioners can be connected?	Up to 64 units can be connected per TCC-LINK line. The controller has two TCC-LINK lines, thus up to 128 units can be connected.
4	How many central remote controllers can be connected?	Up to 10 central remote control devices can be connected per TCC-LINK line. The central control devices include a central remote controller, a schedule timer, and an ON / OFF controller.
5	Is it possible to turn on or off the lighting equipment, fan or any other manufacture's air conditioner?	This is possible by connecting to the general devices control interface.
6	Can a schedule timer be used together?	Possible. Note that schedule must be set so that it does not conflict with the schedule setting from the browser.
7	Can a touch screen-type air conditioning management system be used together?	Not possible. However, it is possible to use a touch screen-type air conditioning management system together with a central control device other than the Web-based central remote controller.
8	Can the BACnet system be used together?	Not possible. However, it is possible to use BACnet system together with a central control device other than the Web-based central remote controller.
9	Can the LONwork system be used together?	Possible. Check that it works.
10	Can a remote monitoring system be used together?	Not possible. However, it is possible to use a remote monitoring system together with a central control device other than the Web-based central remote controller.
11	Can a device in the AI-NETwork series be connected?	Not possible. Use an air conditioning management system supported for the AI-NETwork series.
12	Up to how many PCs can be connected?	Up to 4 users can simultaneously log on.
13	How many users can simultaneously access the system?	Up to 4 PCs can be simultaneously connected. Without simultaneous connection, the number of PCs connected has no limitation.
14	Can the system connect to an intra-company LAN?	Possible. However, check with your network administrator if the connection is available.

No.	Questions	Answer
15	Is connection available via the Internet (WAN)?	Not available.
16	Is connection available from a mobile phone?	
17	If a failure occurs on the air conditioner, can mail be sent?	Not possible.
18	Can a tenant name or other names be changed?	You can use the Setting File Creation Software to change the name of a floor, a tenant, an area, and an air conditioner.
19	Up to how many characters can be used for the name of tenant, etc.?	For a floor name: 20 bytes, for a tenant name: 30 bytes, for an area name: 20 bytes, and for an air conditioner name: 20 bytes.
20	How many items does the alarm history save?	It saves up to 1,024 items. If the alarm history items exceed 1,024, the item is deleted sequentially from the oldest one.
21	How many days of power distribution data does the system save?	The system saves the 45 days of daily report files and the 3 months of monthly report files.
22	Can data be maintained in case of power outage?	Data will be backed up before being saved. If power outage occurs during the data saving, the backup data is restored, thus the data is protected.
23	Does turning off the controller require any specific operation?	No specific operation is necessary.
24	Does turning off the controller stop the air conditioner?	The air conditioner where the remote controller or wireless adaptor is connected does not stop when the controller is turned off. An air conditioner other than the above stops.
25	Does a scheduled operation work only if a PC remains connected?	No. Because the power distribution data are saved inside the controller, the PC does not need to remain connected.
26	Does a PC need to remain connected to save power distribution data?	An alarm can be set to go off with a buzzer or other means connected to the alarm external output of no-voltage A contact.
27	Is it possible to know an air conditioner failure without connecting a PC?	An alarm can be set to go off with a buzzer or other means connected to the alarm external output of no-voltage A contact.
28	How many master schedules can be created?	Up to 32 schedules can be created for each master schedule and billing schedule.
29	How many billing schedules can be created?	
30	What are the PC requirements for connecting to the controller?	1.PC running Window XP or Vista without any problem. Also, the PC must have Internet Explorer Version 6.0, 7.0 or 8.0 or Firefox 2.0, 3.0, 3.5 or 3.6. 2.If you use the Monthly Report Creation Software, you need to install Microsoft Excel 2002 or later on your computer.
31	Can a schedule be separately set for each air conditioner?	One air conditioner can register only one master schedule while 32 master schedules can be created. An operating schedule can be separately set for each air conditioner.
32	What is the billing schedule?	A day is divided into two time frames: on-hours and off-hours, and power is distributed to each time frame. For example, the billing schedule can be used to charge only for the operation during overtime work hours.
33	Can all the indoor units be made stop at a time?	Possible. In the zone window of a PC, select all floors or all tenants and perform setting for the stop. For all the indoor units, set lock interlocking that is activated by the same lock input. (The same as fire alarm interlocking setting) Apply the external input of all stop to the controller.
34	Is monitoring the operation state of the outdoor unit possible?	Not possible.
35	Does setting operation for an air conditioner have any priority?	The button pressed later receives priority.
36	Is it possible to connect an indoor unit without its remote controller?	Possible.
37	Is connection available via VPN?	Available.

14 TEST RUN CHECK

14-1. Check Items Before Trial Run

No.	Check item
1	Has the electrical work (power supply and communication wiring work) been completed? <div style="border: 1px solid black; padding: 5px; margin-top: 10px;"> <p style="text-align: center;">Key point</p> <p>1. When the Energy Monitoring Relay Interface or Digital Input / Output Relay Interface is connected, check that the polarity (A / B) of the wiring is correct. 2. Check that the terminal resistance has been set. 3. When a custom device is connected, check that the TCC-LINK adaptor has been connected.</p> </div>
2	Has the addresses of the air conditioner (Indoor units (DN=03, 12, 13, 14)) and outdoor unit (outdoor unit control board switch 13 / 14) been set? <div style="border: 1px solid black; padding: 5px; margin-top: 10px;"> <p style="text-align: center;">Key point</p> <p>1. Check that the address of the general device interface has been set.</p> </div>
3	Has the setting file been created?
4	Have the controller switch and DN been set?
5	Has the controller IP address been checked?
6	Have the network and the browser proxy of the PC to be connected been set?
7	Are all the devices turned on?
When the power distribution function is used:	
8	Is the Monthly Report Creation Software installed?
9	Is the network setting completed for the PC where the Monthly Report Creation Software is installed?

14-2. Procedure of Test Run Check

No.	Check item	No.	Procedure								
1	PC connection check	1	Start the browser software of the PC to be connected.								
		2	Enter http://the controller's IP address/index.html in the address bar of the browser, and check that the logon window is displayed. <table border="1" style="width: 100%; margin-top: 10px;"> <thead> <tr> <th colspan="2">Error message</th> </tr> </thead> <tbody> <tr> <td>× NG1: Network Error</td> <td>1) Check if the browser proxy is correctly set.</td> </tr> <tr> <td>× NG2: The server is not found.</td> <td>1) Check if the network wiring is correctly installed. (Refer to "15-1. Network Wiring") 2) Check if the PC's IP address is correct. (Refer to "15-2. PC's IP Address") 3) Check if the controller's IP address is correct. (Refer to "15-3. Controller's IP Address")</td> </tr> <tr> <td>○ OK: The logon window is displayed.</td> <td>1) Proceed to the logon check.</td> </tr> </tbody> </table>	Error message		× NG1: Network Error	1) Check if the browser proxy is correctly set.	× NG2: The server is not found.	1) Check if the network wiring is correctly installed. (Refer to "15-1. Network Wiring") 2) Check if the PC's IP address is correct. (Refer to "15-2. PC's IP Address") 3) Check if the controller's IP address is correct. (Refer to "15-3. Controller's IP Address")	○ OK: The logon window is displayed.	1) Proceed to the logon check.
		Error message									
× NG1: Network Error	1) Check if the browser proxy is correctly set.										
× NG2: The server is not found.	1) Check if the network wiring is correctly installed. (Refer to "15-1. Network Wiring") 2) Check if the PC's IP address is correct. (Refer to "15-2. PC's IP Address") 3) Check if the controller's IP address is correct. (Refer to "15-3. Controller's IP Address")										
○ OK: The logon window is displayed.	1) Proceed to the logon check.										
3	After entering TCC in User Name and TCC in Password, click "Logon" and make sure that you can successfully logon. <table border="1" style="width: 100%; margin-top: 10px;"> <thead> <tr> <th colspan="2">Error message</th> </tr> </thead> <tbody> <tr> <td>× NG1: The dialog message, "Logon failed." appears.</td> <td>1) The user name or password entered are incorrect. Logon again with all the characters in upper case.</td> </tr> <tr> <td>× NG2: The dialog message "No response from the server." or "The system is being prepared." appears.</td> <td>1) The controller is being initialized during the startup process. Wait for 5 minutes and logon again.</td> </tr> <tr> <td>× NG3: The dialog message "The system is stopped." appears.</td> <td>1) Close the browser and turn off the controller. Wait for 30 seconds and turn on the controller. Wait for 5 minutes and logon again. 2) If the dialog message "The system is stopping." appears again, initialize the setting file with the Setting File Creation Software and turn off the controller. Wait for 30 seconds and turn on the controller. Wait for 5 minutes and logon again. 3) When successfully logging on after the initialization, upload again the setting file created, and check that you can logon.</td> </tr> <tr> <td>○ OK: The list window displays the indoor units set in the setting file.</td> <td>1) Proceed to the next check.</td> </tr> </tbody> </table>	Error message		× NG1: The dialog message, "Logon failed." appears.	1) The user name or password entered are incorrect. Logon again with all the characters in upper case.	× NG2: The dialog message "No response from the server." or "The system is being prepared." appears.	1) The controller is being initialized during the startup process. Wait for 5 minutes and logon again.	× NG3: The dialog message "The system is stopped." appears.	1) Close the browser and turn off the controller. Wait for 30 seconds and turn on the controller. Wait for 5 minutes and logon again. 2) If the dialog message "The system is stopping." appears again, initialize the setting file with the Setting File Creation Software and turn off the controller. Wait for 30 seconds and turn on the controller. Wait for 5 minutes and logon again. 3) When successfully logging on after the initialization, upload again the setting file created, and check that you can logon.	○ OK: The list window displays the indoor units set in the setting file.	1) Proceed to the next check.
Error message											
× NG1: The dialog message, "Logon failed." appears.	1) The user name or password entered are incorrect. Logon again with all the characters in upper case.										
× NG2: The dialog message "No response from the server." or "The system is being prepared." appears.	1) The controller is being initialized during the startup process. Wait for 5 minutes and logon again.										
× NG3: The dialog message "The system is stopped." appears.	1) Close the browser and turn off the controller. Wait for 30 seconds and turn on the controller. Wait for 5 minutes and logon again. 2) If the dialog message "The system is stopping." appears again, initialize the setting file with the Setting File Creation Software and turn off the controller. Wait for 30 seconds and turn on the controller. Wait for 5 minutes and logon again. 3) When successfully logging on after the initialization, upload again the setting file created, and check that you can logon.										
○ OK: The list window displays the indoor units set in the setting file.	1) Proceed to the next check.										

No.	Check item	No.	Procedure						
2	Controller operation check	1.	<p>1. Turn on the controller and check that the LCD displays "Line" and "All".</p> <table border="1" data-bbox="609 327 1431 510"> <thead> <tr> <th colspan="2" data-bbox="609 327 1431 365">Error message</th> </tr> </thead> <tbody> <tr> <td data-bbox="609 365 876 510"> × NG: The frame line only is displayed; no "Line" or "All" are displayed. </td> <td data-bbox="876 365 1431 510"> 1) Check if the controller is turned on. 2) Check if the controller internal wiring is defective or connector is properly inserted. 3) Check the power line wiring between the controller and the power unit. </td> </tr> </tbody> </table>	Error message		× NG: The frame line only is displayed; no "Line" or "All" are displayed.	1) Check if the controller is turned on. 2) Check if the controller internal wiring is defective or connector is properly inserted. 3) Check the power line wiring between the controller and the power unit.		
		Error message							
× NG: The frame line only is displayed; no "Line" or "All" are displayed.	1) Check if the controller is turned on. 2) Check if the controller internal wiring is defective or connector is properly inserted. 3) Check the power line wiring between the controller and the power unit.								
2.	<p>3. Check that the LCD displays the group numbers of all the indoor units connected. When the indoor units are connected to Line 1 and Line 2, press the [LINE] button to switch the line, and check the group number. (When the air conditioner is connected to either Line 1 or Line 2, pressing the [Line Switch] button does not switch the line.)</p> <table border="1" data-bbox="609 689 1431 1151"> <thead> <tr> <th colspan="2" data-bbox="609 689 1431 728">Error message</th> </tr> </thead> <tbody> <tr> <td data-bbox="609 728 876 864"> × NG1: The number of line where the air conditioner is connected is not displayed. </td> <td data-bbox="876 728 1431 864"> Check if the TCC-LINK wiring is properly installed. (Refer to "15-4. TCC-LINK Wiring") </td> </tr> <tr> <td data-bbox="609 864 876 1023"> × NG2: The number of group numbers displayed is less than expected, or some numbers are missing. </td> <td data-bbox="876 864 1431 1023"> With the handy remote controller of the indoor unit whose group number is not displayed, check if the central address setting is correct. </td> </tr> <tr> <td data-bbox="609 1023 876 1151"> ○ OK: The group numbers of all the indoor units connected are displayed </td> <td data-bbox="876 1023 1431 1151"> Proceed to the next check. </td> </tr> </tbody> </table>	Error message		× NG1: The number of line where the air conditioner is connected is not displayed.	Check if the TCC-LINK wiring is properly installed. (Refer to "15-4. TCC-LINK Wiring")	× NG2: The number of group numbers displayed is less than expected, or some numbers are missing.	With the handy remote controller of the indoor unit whose group number is not displayed, check if the central address setting is correct.	○ OK: The group numbers of all the indoor units connected are displayed	Proceed to the next check.
Error message									
× NG1: The number of line where the air conditioner is connected is not displayed.	Check if the TCC-LINK wiring is properly installed. (Refer to "15-4. TCC-LINK Wiring")								
× NG2: The number of group numbers displayed is less than expected, or some numbers are missing.	With the handy remote controller of the indoor unit whose group number is not displayed, check if the central address setting is correct.								
○ OK: The group numbers of all the indoor units connected are displayed	Proceed to the next check.								

No.	Check item	No.	Procedure						
3	Air conditioner connection check (Facing test)	1	In the zone window, select all the floors and display the "General" tab.						
		2	<p>Check if all the indoor unit operation statuses are obtained (if the units are connected).</p> <table border="1" data-bbox="609 365 1433 925"> <thead> <tr> <th colspan="2" data-bbox="609 365 1433 403">Error message</th> </tr> </thead> <tbody> <tr> <td data-bbox="609 403 876 495"> × NG1: The display is as follows. Mode: blank, Set temperature: - 35, Fan: blank. </td> <td data-bbox="876 403 1433 495"></td> </tr> <tr> <td data-bbox="609 495 876 797"> × NG2: The alarm C06 (TCC-LINK central management device receive failure) has occurred. </td> <td data-bbox="876 495 1433 797"> 1) Check that the handy remote controller of the air conditioner whose operation status is not obtained is on. 2) Check if the handy remote controller does not display any check code. 3) Press the [UNIT] button of the handy remote controller to display the unit number, and check if the number matches that in the setting file. 4) Check if LINE_No. of the TCC-LINK terminal blocks of the connected controller matches that in the setting file. </td> </tr> <tr> <td data-bbox="609 797 876 925"> ○ OK: All the indoor units operation statuses are displayed. </td> <td data-bbox="876 797 1433 925"> Proceed to the next check. </td> </tr> </tbody> </table>	Error message		× NG1: The display is as follows. Mode: blank, Set temperature: - 35, Fan: blank.		× NG2: The alarm C06 (TCC-LINK central management device receive failure) has occurred.	1) Check that the handy remote controller of the air conditioner whose operation status is not obtained is on. 2) Check if the handy remote controller does not display any check code. 3) Press the [UNIT] button of the handy remote controller to display the unit number, and check if the number matches that in the setting file. 4) Check if LINE_No. of the TCC-LINK terminal blocks of the connected controller matches that in the setting file.
Error message									
× NG1: The display is as follows. Mode: blank, Set temperature: - 35, Fan: blank.									
× NG2: The alarm C06 (TCC-LINK central management device receive failure) has occurred.	1) Check that the handy remote controller of the air conditioner whose operation status is not obtained is on. 2) Check if the handy remote controller does not display any check code. 3) Press the [UNIT] button of the handy remote controller to display the unit number, and check if the number matches that in the setting file. 4) Check if LINE_No. of the TCC-LINK terminal blocks of the connected controller matches that in the setting file.								
○ OK: All the indoor units operation statuses are displayed.	Proceed to the next check.								
3	<p>Check that the air conditioner displayed on the PC matches that actually installed.</p> <table border="1" data-bbox="609 999 1433 1615"> <thead> <tr> <th colspan="2" data-bbox="609 999 1433 1037">Error message</th> </tr> </thead> <tbody> <tr> <td data-bbox="609 1037 876 1317"> × NG1: An setting operation from the PC does not change the setting in the remote controller. </td> <td data-bbox="876 1037 1433 1317"> 1) Change the setting with the handy remote controller, and check if the display on the PC matches that in the remote controller. 2) If the display on the PC matches, check with the handy remote controller if the main unit is set. 3) If the display on the PC does not match, <ul style="list-style-type: none"> • Press the [UNIT] button of the handy remote controller to display the unit number, and check if the number matches that in the setting file. • Check if LINE_No. of the TCC-LINK terminal blocks of the connected controller matches that in the setting file. </td> </tr> <tr> <td data-bbox="609 1317 876 1451"> × NG2: The floor, tenant, and area names do not match those of the installation location. </td> <td data-bbox="876 1317 1433 1451"> 1) Check if the floor, tenant, area names are correctly entered in the [Indoor unit group definition] sheet of the setting file. </td> </tr> <tr> <td data-bbox="609 1451 876 1615"> ○ OK: The air conditioner displayed on the PC matches the one installed. </td> <td data-bbox="876 1451 1433 1615"> Proceed to the next check. </td> </tr> </tbody> </table>	Error message		× NG1: An setting operation from the PC does not change the setting in the remote controller.	1) Change the setting with the handy remote controller, and check if the display on the PC matches that in the remote controller. 2) If the display on the PC matches, check with the handy remote controller if the main unit is set. 3) If the display on the PC does not match, <ul style="list-style-type: none"> • Press the [UNIT] button of the handy remote controller to display the unit number, and check if the number matches that in the setting file. • Check if LINE_No. of the TCC-LINK terminal blocks of the connected controller matches that in the setting file. 	× NG2: The floor, tenant, and area names do not match those of the installation location.	1) Check if the floor, tenant, area names are correctly entered in the [Indoor unit group definition] sheet of the setting file.	○ OK: The air conditioner displayed on the PC matches the one installed.	Proceed to the next check.
Error message									
× NG1: An setting operation from the PC does not change the setting in the remote controller.	1) Change the setting with the handy remote controller, and check if the display on the PC matches that in the remote controller. 2) If the display on the PC matches, check with the handy remote controller if the main unit is set. 3) If the display on the PC does not match, <ul style="list-style-type: none"> • Press the [UNIT] button of the handy remote controller to display the unit number, and check if the number matches that in the setting file. • Check if LINE_No. of the TCC-LINK terminal blocks of the connected controller matches that in the setting file. 								
× NG2: The floor, tenant, and area names do not match those of the installation location.	1) Check if the floor, tenant, area names are correctly entered in the [Indoor unit group definition] sheet of the setting file.								
○ OK: The air conditioner displayed on the PC matches the one installed.	Proceed to the next check.								

No.	Check item	No.	Procedure						
4	Digital Input / Output Relay Interface connection check		Check the connection when the Digital Input / Output Relay Interface is connected and the locking or fire alarm interlocking is set.						
		1	Display "Alarm List" on the PC, and check that the S07:BMS-IFDD communication error is not detected. <table border="1" data-bbox="611 461 1433 689"> <thead> <tr> <th colspan="2" data-bbox="611 461 1433 499">Error message</th> </tr> </thead> <tbody> <tr> <td data-bbox="611 499 876 589">× NG: The S07 alarm is displayed.</td> <td data-bbox="876 499 1433 589">1) Check if RS-485 communication is in the normal state. (Refer to "15-6. RS-485 Communication Check")</td> </tr> <tr> <td data-bbox="611 589 876 689">○ OK: The S07 alarm is not displayed.</td> <td data-bbox="876 589 1433 689">Proceed to the next check.</td> </tr> </tbody> </table>	Error message		× NG: The S07 alarm is displayed.	1) Check if RS-485 communication is in the normal state. (Refer to "15-6. RS-485 Communication Check")	○ OK: The S07 alarm is not displayed.	Proceed to the next check.
		Error message							
		× NG: The S07 alarm is displayed.	1) Check if RS-485 communication is in the normal state. (Refer to "15-6. RS-485 Communication Check")						
		○ OK: The S07 alarm is not displayed.	Proceed to the next check.						
		2	Enter a locking signal in the Digital Input / Output Relay Interface, and check that the set air conditioner stops. <table border="1" data-bbox="611 786 1433 1178"> <thead> <tr> <th colspan="2" data-bbox="611 786 1433 824">Error message</th> </tr> </thead> <tbody> <tr> <td data-bbox="611 824 876 1077">× NG: The set air conditioner does not stop.</td> <td data-bbox="876 824 1433 1077"> 1) In the test mode, check with the LED on the Digital Input / Output Relay Interface if the locking signal has been input in the interface. (For further details, refer to "7. Trial Operation Check - Confirming external input connection" in the Owner's manual of Digital Input / Output Relay Interface.) 2) Check if the locking input name is correctly entered in the [Indoor unit group definition] sheet of the setting file. </td> </tr> <tr> <td colspan="2" data-bbox="611 1077 1433 1178">○ OK: The set locking signals are individually input, and the air conditioners set for the locking signals stop accordingly.</td> </tr> </tbody> </table>	Error message		× NG: The set air conditioner does not stop.	1) In the test mode, check with the LED on the Digital Input / Output Relay Interface if the locking signal has been input in the interface. (For further details, refer to "7. Trial Operation Check - Confirming external input connection" in the Owner's manual of Digital Input / Output Relay Interface.) 2) Check if the locking input name is correctly entered in the [Indoor unit group definition] sheet of the setting file.	○ OK: The set locking signals are individually input, and the air conditioners set for the locking signals stop accordingly.	
		Error message							
		× NG: The set air conditioner does not stop.	1) In the test mode, check with the LED on the Digital Input / Output Relay Interface if the locking signal has been input in the interface. (For further details, refer to "7. Trial Operation Check - Confirming external input connection" in the Owner's manual of Digital Input / Output Relay Interface.) 2) Check if the locking input name is correctly entered in the [Indoor unit group definition] sheet of the setting file.						
		○ OK: The set locking signals are individually input, and the air conditioners set for the locking signals stop accordingly.							
			Fire alarm interlocking operation check						
1	Display "Alarm List" on the PC, and check that the S07:BMS-IFDD communication error is not detected. <table border="1" data-bbox="611 1312 1433 1541"> <thead> <tr> <th colspan="2" data-bbox="611 1312 1433 1350">Error message</th> </tr> </thead> <tbody> <tr> <td data-bbox="611 1350 876 1440">× NG: The S07 alarm is displayed.</td> <td data-bbox="876 1350 1433 1440">1) Check if RS-485 communication is in the normal state. (Refer to "15-6. RS-485 Communication Check")</td> </tr> <tr> <td data-bbox="611 1440 876 1541">○ OK: The S07 alarm is not displayed.</td> <td data-bbox="876 1440 1433 1541">Proceed to the next check.</td> </tr> </tbody> </table>	Error message		× NG: The S07 alarm is displayed.	1) Check if RS-485 communication is in the normal state. (Refer to "15-6. RS-485 Communication Check")	○ OK: The S07 alarm is not displayed.	Proceed to the next check.		
Error message									
× NG: The S07 alarm is displayed.	1) Check if RS-485 communication is in the normal state. (Refer to "15-6. RS-485 Communication Check")								
○ OK: The S07 alarm is not displayed.	Proceed to the next check.								
2	Enter a fire alarm signal in the Digital Input / Output Relay Interface, and check that the set air conditioner stops. <table border="1" data-bbox="611 1630 1433 2022"> <thead> <tr> <th colspan="2" data-bbox="611 1630 1433 1668">Error message</th> </tr> </thead> <tbody> <tr> <td data-bbox="611 1668 876 1921">× NG: The set air conditioner does not stop.</td> <td data-bbox="876 1668 1433 1921"> 1) In the test mode, check with the LED on the interface if the locking signal has been input in the Digital Input / Output Relay Interface. (For further details, refer to "7. Trial Operation Check - Confirming external input connection" in the Owner's manual of Digital Input / Output Relay Interface.) 2) Check if the fire alarm input name is correctly entered in the [Indoor unit group definition] sheet of the setting file. </td> </tr> <tr> <td colspan="2" data-bbox="611 1921 1433 2022">○ OK: The set fire alarm signals are individually input, and the air conditioners set for the locking signals stop accordingly.</td> </tr> </tbody> </table>	Error message		× NG: The set air conditioner does not stop.	1) In the test mode, check with the LED on the interface if the locking signal has been input in the Digital Input / Output Relay Interface. (For further details, refer to "7. Trial Operation Check - Confirming external input connection" in the Owner's manual of Digital Input / Output Relay Interface.) 2) Check if the fire alarm input name is correctly entered in the [Indoor unit group definition] sheet of the setting file.	○ OK: The set fire alarm signals are individually input, and the air conditioners set for the locking signals stop accordingly.			
Error message									
× NG: The set air conditioner does not stop.	1) In the test mode, check with the LED on the interface if the locking signal has been input in the Digital Input / Output Relay Interface. (For further details, refer to "7. Trial Operation Check - Confirming external input connection" in the Owner's manual of Digital Input / Output Relay Interface.) 2) Check if the fire alarm input name is correctly entered in the [Indoor unit group definition] sheet of the setting file.								
○ OK: The set fire alarm signals are individually input, and the air conditioners set for the locking signals stop accordingly.									

No.	Check item	No.	Procedure						
5	Energy Monitoring Relay Interface connection check		Check the connection when the Energy Monitoring Relay Interface is connected and an energy meter input name is set in the setting file.						
		1	<p>Display "Alarm List" on the PC, and check that the S06:BMS-IFWH communication error is not detected.</p> <table border="1"> <thead> <tr> <th colspan="2">Error message</th> </tr> </thead> <tbody> <tr> <td>× NG: The S06 alarm is displayed.</td> <td>1) Check if RS-485 communication is in the normal state. (Refer to "15-6. RS-485 Communication Check")</td> </tr> <tr> <td>○ OK: The S06 alarm is not displayed.</td> <td>Proceed to the next check.</td> </tr> </tbody> </table>	Error message		× NG: The S06 alarm is displayed.	1) Check if RS-485 communication is in the normal state. (Refer to "15-6. RS-485 Communication Check")	○ OK: The S06 alarm is not displayed.	Proceed to the next check.
Error message									
× NG: The S06 alarm is displayed.	1) Check if RS-485 communication is in the normal state. (Refer to "15-6. RS-485 Communication Check")								
○ OK: The S06 alarm is not displayed.	Proceed to the next check.								
		2	<p>Use the energy meter integrated value check tool to check that a pulse from the energy meter has been input to the Energy Monitoring Relay Interface.</p> <table border="1"> <thead> <tr> <th colspan="2">Error message</th> </tr> </thead> <tbody> <tr> <td>× NG1: After the several-hour operation of the air conditioner, the pulse integrated value does not change.</td> <td>1) In the test mode, check with the LED on the Energy Monitoring Relay Interface if the pulse from the energy meter has been input in the interface. (For further details, refer to "7. Trial Operation Check - Confirming external input connection" in the Owner's manual of Energy Monitoring Relay Interface.)</td> </tr> <tr> <td>○ OK: The pulse integrated values of all the energy meter set in the setting file have changed.</td> <td>Proceed to the next check.</td> </tr> </tbody> </table>	Error message		× NG1: After the several-hour operation of the air conditioner, the pulse integrated value does not change.	1) In the test mode, check with the LED on the Energy Monitoring Relay Interface if the pulse from the energy meter has been input in the interface. (For further details, refer to "7. Trial Operation Check - Confirming external input connection" in the Owner's manual of Energy Monitoring Relay Interface.)	○ OK: The pulse integrated values of all the energy meter set in the setting file have changed.	Proceed to the next check.
Error message									
× NG1: After the several-hour operation of the air conditioner, the pulse integrated value does not change.	1) In the test mode, check with the LED on the Energy Monitoring Relay Interface if the pulse from the energy meter has been input in the interface. (For further details, refer to "7. Trial Operation Check - Confirming external input connection" in the Owner's manual of Energy Monitoring Relay Interface.)								
○ OK: The pulse integrated values of all the energy meter set in the setting file have changed.	Proceed to the next check.								
6	Power distribution check	1	Operate the air conditioner for several hours with the controller in operation.						
		2	Perform manual meter-reading from the PC. "Option" > "Manual Meter-Reading" > "Go" (Do not select "don't continue data reading".)						
		3	Wait for approx. 1 minute until a manual meter-reading file is created.						
		4	Selecting "Option" > "Manual Meter-Reading" displays the file created in "Data reading completed".						
		5	Download a monthly report file with the Monthly Report Creation Software.						
		6	Select the file displayed in (4) in [File setting].						
		7	Check the output result of the monthly report created.						
7	Scheduled operation check		—						
8	PC connection check on site		—						

15 CHECK POINTS



15-1. Network Wiring

No.	Check point										
1	Check that the LAN cable is connected to the connector on the upper side of the controller, and the connector's LED illuminates.										
2	Check that the LAN cable is connected to the PC that is connected to the controller via the network, and check that the PC operates normally. (To check the connection, click "Control Panel" -> "Network Connections".)										
3	If a hub or router is installed between the controller and PC, check the power source, wiring, and setting of the hub or router.										
4	Issue the ping command from the PC to check if the network communication is normal. <table border="1" style="width: 100%; margin-top: 10px;"> <thead> <tr> <th colspan="2">Error message</th> </tr> </thead> <tbody> <tr> <td colspan="2">In the command prompt window, enter "ping 192.168.2.30". If the controller's IP address has been changed from 192.168.2.30, enter the changed address.</td> </tr> <tr> <td colspan="2">○ OK: "Reply from 192.168.2.30" or "Reply from the controller's IP address" is displayed.</td> </tr> <tr> <td>× NG1: "Destination host unreachable." is displayed.</td> <td>Check if the PC's IP address is correct.</td> </tr> <tr> <td>× NG2: "Request time out" is displayed.</td> <td>Check if the controller's IP address is correct.</td> </tr> </tbody> </table>	Error message		In the command prompt window, enter "ping 192.168.2.30". If the controller's IP address has been changed from 192.168.2.30, enter the changed address.		○ OK: "Reply from 192.168.2.30" or "Reply from the controller's IP address" is displayed.		× NG1: "Destination host unreachable." is displayed.	Check if the PC's IP address is correct.	× NG2: "Request time out" is displayed.	Check if the controller's IP address is correct.
Error message											
In the command prompt window, enter "ping 192.168.2.30". If the controller's IP address has been changed from 192.168.2.30, enter the changed address.											
○ OK: "Reply from 192.168.2.30" or "Reply from the controller's IP address" is displayed.											
× NG1: "Destination host unreachable." is displayed.	Check if the PC's IP address is correct.										
× NG2: "Request time out" is displayed.	Check if the controller's IP address is correct.										

15-2. PC's IP Address

No.	Check point
1	In the command prompt window, enter "ipconfig" to show the PC's IP address. "IP Address192.168.2.90" or the like is displayed.
2	If no router is used, check that the subnet of the PC is the same as that of the controller.
3	If a router is used, check that the address of Default Gateway is set.

15-3. Controller's IP Address

No.	Check point
1	Press the [CHECK], [CL], and [ZONE ] buttons simultaneously for 4 seconds or longer to enable the item code setting change mode.
2	Use the [SET TEMP.  ] button to switch the item code to 10 through 1B, and check the IP address.
3	For further details, refer to "4-1. Displaying IP address" in the Network Configuration Guide of the Smart Manager.

15-4. TCC-LINK Wiring

No.	Check point
1	Check that the wiring is connected to the TCC-LINK terminal block of the controller.
2	Turn the controller's terminal resistance switch DS1 to OFF, and check that the resistance between U1 / U3 and U2 / U4 of the TCC-LINK terminal block is the terminal value (approx. 100 ohm). This check can determine that the wiring is normal in the system where the terminal resistance is set.
3	For all the centre machine of the multi outdoor units, check that the relay connector between the "U1U2" and "U3U4" terminals is connected.
4	If a custom air conditioner is connected, check that the TCC-LINK adaptor is connected to the main unit of the indoor unit.

15-5. Facing Test

No.	Check point
1	At both sides of the controller and handy remote controller, perform setting and display check.
2	Before starting the check, discuss and determine the air conditioners checking order and procedure.
3	Check 1: Check that the unit name and operation state match between the controller and the handy remote controller.
4	Check 2: Check that the setting operation from the controller can change the setting in the handy remote controller.
5	Check 3: Check that returning the setting to the previous state in the handy remote controller can change the setting in the controller.
6	Proceed to the next air conditioner with check.

15-6. RS-485 Communication Check

No.	Check point								
1	At both the Digital Input / Output Relay Interface and the Energy Monitoring Relay Interface, check that the POWER LED1 (Red) is lit and the RS-485 LED2 (Green) is blinking. <table border="1" style="width: 100%; margin-top: 10px;"> <thead> <tr> <th colspan="2">Error message</th> </tr> </thead> <tbody> <tr> <td style="width: 50%;">× NG1: The POWER LED1 (Red) is off.</td> <td>Check if the Digital Input / Output Relay Interface or the Energy Monitoring Relay Interface is turned on.</td> </tr> <tr> <td>× NG2: The RS-485 LED2 (Green) is off.</td> <td>Check the RS-485 wiring as shown in the step (2) and the subsequent steps below.</td> </tr> <tr> <td>○ OK: The RS-485 LED2 (Green) is blinking.</td> <td>When the LED2 (Green) is blinking, if S06:BMS-IFWH communication error or S07:BMS-IFDD communication error occurs, perform (6) shown below.</td> </tr> </tbody> </table>	Error message		× NG1: The POWER LED1 (Red) is off.	Check if the Digital Input / Output Relay Interface or the Energy Monitoring Relay Interface is turned on.	× NG2: The RS-485 LED2 (Green) is off.	Check the RS-485 wiring as shown in the step (2) and the subsequent steps below.	○ OK: The RS-485 LED2 (Green) is blinking.	When the LED2 (Green) is blinking, if S06:BMS-IFWH communication error or S07:BMS-IFDD communication error occurs, perform (6) shown below.
Error message									
× NG1: The POWER LED1 (Red) is off.	Check if the Digital Input / Output Relay Interface or the Energy Monitoring Relay Interface is turned on.								
× NG2: The RS-485 LED2 (Green) is off.	Check the RS-485 wiring as shown in the step (2) and the subsequent steps below.								
○ OK: The RS-485 LED2 (Green) is blinking.	When the LED2 (Green) is blinking, if S06:BMS-IFWH communication error or S07:BMS-IFDD communication error occurs, perform (6) shown below.								
2	Check that the wiring is connected to the RS-485 terminal block of the controller.								
3	Check that the wiring is connected to the RS-485 terminal blocks of the Digital Input / Output Relay Interface and the Energy Monitoring Relay Interface.								
4	Check that the wiring polarity (+), (-) is correct.								
5	Check that the address and switch are correctly set for the Digital Input / Output Relay Interface and the Energy Monitoring Relay Interface.								
6	Check that the settings in the "System equipment configuration" and "Address Setting" sheets in the setting file match the address setting of the Digital Input / Output Relay Interface or the Energy Monitoring Relay Interface.								

15-7. Checking on RS-485 Send and Receive Circuit of the Controller and Interface

No.	Check point				
1	Check that the RS-485 LED2 (Green) of the interface is blinking. <table border="1" style="width: 100%; margin-top: 10px;"> <thead> <tr> <th colspan="2">Error message</th> </tr> </thead> <tbody> <tr> <td colspan="2">○ OK: The RS-485 send circuit of the controller is normal. The RS-485 receive circuit of the interface is normal.</td> </tr> </tbody> </table>	Error message		○ OK: The RS-485 send circuit of the controller is normal. The RS-485 receive circuit of the interface is normal.	
Error message					
○ OK: The RS-485 send circuit of the controller is normal. The RS-485 receive circuit of the interface is normal.					

No.	Check point						
2	<p>Check the RS-485 send circuit of the interface.</p> <table border="1"> <thead> <tr> <th colspan="2">Error message</th> </tr> </thead> <tbody> <tr> <td colspan="2">Enable the test mode 2 at the interface, and check that communication waveform is output between A and B of the RS-485 terminal block of the interface.</td> </tr> <tr> <td colspan="2">○ OK: The RS-485 send circuit of the interface is normal.</td> </tr> </tbody> </table>	Error message		Enable the test mode 2 at the interface, and check that communication waveform is output between A and B of the RS-485 terminal block of the interface.		○ OK: The RS-485 send circuit of the interface is normal.	
Error message							
Enable the test mode 2 at the interface, and check that communication waveform is output between A and B of the RS-485 terminal block of the interface.							
○ OK: The RS-485 send circuit of the interface is normal.							
3	<p>Check the RS-485 send circuit of the controller.</p> <table border="1"> <thead> <tr> <th colspan="2">Error message</th> </tr> </thead> <tbody> <tr> <td colspan="2">After checking that the Digital Input / Output Relay Interface or the Energy Monitoring Relay Interface is set in the setting file, check that communication waveform is output between A and B of the RS-485 terminal block of the controller.</td> </tr> <tr> <td colspan="2">○ OK: The RS-485 send circuit of the controller is normal.</td> </tr> </tbody> </table>	Error message		After checking that the Digital Input / Output Relay Interface or the Energy Monitoring Relay Interface is set in the setting file, check that communication waveform is output between A and B of the RS-485 terminal block of the controller.		○ OK: The RS-485 send circuit of the controller is normal.	
Error message							
After checking that the Digital Input / Output Relay Interface or the Energy Monitoring Relay Interface is set in the setting file, check that communication waveform is output between A and B of the RS-485 terminal block of the controller.							
○ OK: The RS-485 send circuit of the controller is normal.							

15-8. How to Identify Defective Part at C06 (Receive Failure with TCC-LINK Central Management Device) Occurrence

No.	Check point						
1	<p>Check with the handy remote controller if E04 (Indoor and outdoor communication circuit failure) has occurred.</p> <table border="1"> <thead> <tr> <th colspan="2">Error message</th> </tr> </thead> <tbody> <tr> <td>(If E04 has occurred)</td> <td> <ul style="list-style-type: none"> Defective part: TCC-LINK wiring Solution: Check the connection for each outdoor unit system, and identify the defective part (the outdoor system) in the communication wiring. </td> </tr> <tr> <td>(If no E04 has occurred)</td> <td> <ul style="list-style-type: none"> Defective part: TCC-LINK wiring between the indoor unit and the controller. Solution: Perform the following checks. </td> </tr> </tbody> </table>	Error message		(If E04 has occurred)	<ul style="list-style-type: none"> Defective part: TCC-LINK wiring Solution: Check the connection for each outdoor unit system, and identify the defective part (the outdoor system) in the communication wiring. 	(If no E04 has occurred)	<ul style="list-style-type: none"> Defective part: TCC-LINK wiring between the indoor unit and the controller. Solution: Perform the following checks.
Error message							
(If E04 has occurred)	<ul style="list-style-type: none"> Defective part: TCC-LINK wiring Solution: Check the connection for each outdoor unit system, and identify the defective part (the outdoor system) in the communication wiring. 						
(If no E04 has occurred)	<ul style="list-style-type: none"> Defective part: TCC-LINK wiring between the indoor unit and the controller. Solution: Perform the following checks. 						
2	<p>Check if the C06 occurred on all the air conditioners or on some of them.</p> <table border="1"> <thead> <tr> <th colspan="2">Error message</th> </tr> </thead> <tbody> <tr> <td>(When occurred on some of the air conditioners)</td> <td> <ul style="list-style-type: none"> Defective part: TCC-LINK wiring on the air conditioners Solution: Identify the defective part of the communication wiring based on the C06 occurrence location and the schematic, and check the wiring connection state and the continuity. </td> </tr> <tr> <td>(When occurred on all of the air conditioners)</td> <td> <ul style="list-style-type: none"> Defective part: TCC-LINK wiring on the controller Solution: Check the communication wiring continuity. </td> </tr> </tbody> </table>	Error message		(When occurred on some of the air conditioners)	<ul style="list-style-type: none"> Defective part: TCC-LINK wiring on the air conditioners Solution: Identify the defective part of the communication wiring based on the C06 occurrence location and the schematic, and check the wiring connection state and the continuity. 	(When occurred on all of the air conditioners)	<ul style="list-style-type: none"> Defective part: TCC-LINK wiring on the controller Solution: Check the communication wiring continuity.
Error message							
(When occurred on some of the air conditioners)	<ul style="list-style-type: none"> Defective part: TCC-LINK wiring on the air conditioners Solution: Identify the defective part of the communication wiring based on the C06 occurrence location and the schematic, and check the wiring connection state and the continuity. 						
(When occurred on all of the air conditioners)	<ul style="list-style-type: none"> Defective part: TCC-LINK wiring on the controller Solution: Check the communication wiring continuity. 						
3	<p>Check if the address setting in the setting file matches that of the air conditioner.</p> <table border="1"> <thead> <tr> <th colspan="2">Error message</th> </tr> </thead> <tbody> <tr> <td colspan="2"> <ul style="list-style-type: none"> Defective part: The address setting in the setting file or the air conditioner. Solution: Change the address in the setting file or the air conditioner. </td> </tr> </tbody> </table>	Error message		<ul style="list-style-type: none"> Defective part: The address setting in the setting file or the air conditioner. Solution: Change the address in the setting file or the air conditioner. 			
Error message							
<ul style="list-style-type: none"> Defective part: The address setting in the setting file or the air conditioner. Solution: Change the address in the setting file or the air conditioner. 							

15-9. How to Identify Defective Part at S06 (BMS-IFWH Communication Error) or S07 (BMS-IFDD Communication Error) Occurrence

No.	Check point						
1	<p>Check if the RS-485 LED (Green) is blinking at the Energy Monitoring Relay Interface or the Digital Input / Output Relay Interface.</p> <table border="1" style="width: 100%;"> <thead> <tr> <th colspan="2" style="text-align: center;">Error message</th> </tr> </thead> <tbody> <tr> <td style="width: 40%;">(If blinking)</td> <td> Defective part: 1.The RS-485 send circuit of the interface 2.Duplicate setting of the interface address 3.The RS-485 receive circuit of the controller </td> </tr> <tr> <td>(If the LED is not blinking)</td> <td> Defective part: 1.The RS-485 wiring 2.The RS-485 send circuit of the controller 3.The power source or switch setting of the interface. 4.The RS-485 receive circuit of the interface </td> </tr> </tbody> </table>	Error message		(If blinking)	Defective part: 1.The RS-485 send circuit of the interface 2.Duplicate setting of the interface address 3.The RS-485 receive circuit of the controller	(If the LED is not blinking)	Defective part: 1.The RS-485 wiring 2.The RS-485 send circuit of the controller 3.The power source or switch setting of the interface. 4.The RS-485 receive circuit of the interface
Error message							
(If blinking)	Defective part: 1.The RS-485 send circuit of the interface 2.Duplicate setting of the interface address 3.The RS-485 receive circuit of the controller						
(If the LED is not blinking)	Defective part: 1.The RS-485 wiring 2.The RS-485 send circuit of the controller 3.The power source or switch setting of the interface. 4.The RS-485 receive circuit of the interface						
2	<p>Check that S06 or S07 has occurred on all the interfaces.</p> <table border="1" style="width: 100%;"> <thead> <tr> <th colspan="2" style="text-align: center;">Error message</th> </tr> </thead> <tbody> <tr> <td style="width: 40%;">(When they have occurred on some of the interfaces)</td> <td> <ul style="list-style-type: none"> • Defective part: The RS-485 wiring on the interfaces • Solution: Identify the defective part of the communication wiring based on the S06 or S07 occurrence location and the schematic, and check the communication wiring connection state, continuity, and polarity. </td> </tr> <tr> <td>(When they have occurred on all of the air conditioners)</td> <td> <ul style="list-style-type: none"> • Defective part: The RS-485 wiring on the controller • Solution: Check the communication wiring continuity and polarity. </td> </tr> </tbody> </table>	Error message		(When they have occurred on some of the interfaces)	<ul style="list-style-type: none"> • Defective part: The RS-485 wiring on the interfaces • Solution: Identify the defective part of the communication wiring based on the S06 or S07 occurrence location and the schematic, and check the communication wiring connection state, continuity, and polarity. 	(When they have occurred on all of the air conditioners)	<ul style="list-style-type: none"> • Defective part: The RS-485 wiring on the controller • Solution: Check the communication wiring continuity and polarity.
Error message							
(When they have occurred on some of the interfaces)	<ul style="list-style-type: none"> • Defective part: The RS-485 wiring on the interfaces • Solution: Identify the defective part of the communication wiring based on the S06 or S07 occurrence location and the schematic, and check the communication wiring connection state, continuity, and polarity. 						
(When they have occurred on all of the air conditioners)	<ul style="list-style-type: none"> • Defective part: The RS-485 wiring on the controller • Solution: Check the communication wiring continuity and polarity. 						

16 EXPLODED VIEWS AND PARTS LIST

16-1. EXPLODED VIEWS

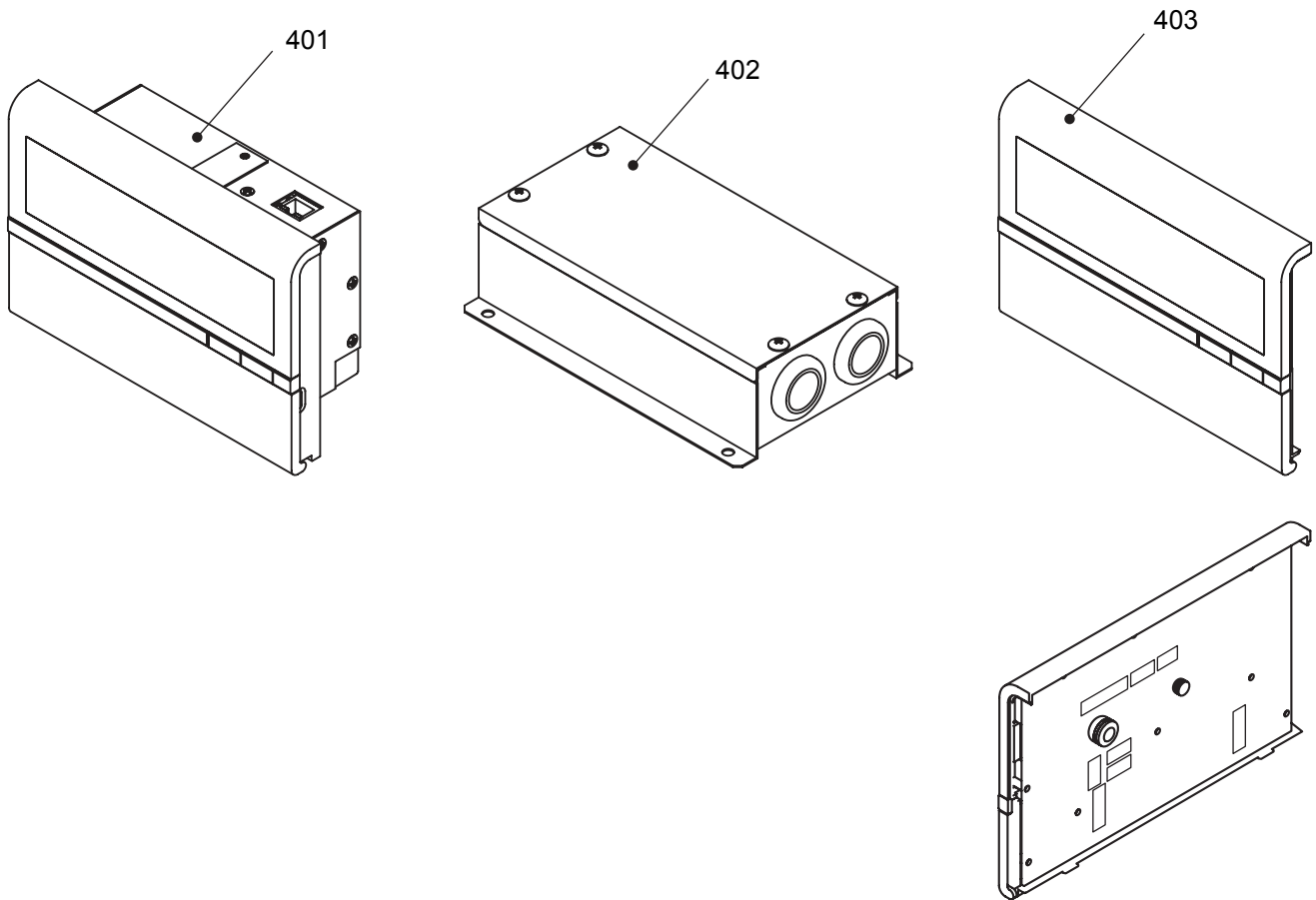

16-2. PARTS LIST

Location No.	Parts No.	Description
401	4316V463	CONTROLLER
402	4316V464	ELECTRIC PARTS ASSY
403	43108027	PANEL

TOSHIBA CARRIER CORPORATION
336 TADEHARA, FUJI-SHI, SHIZUOKA-KEN 416-8521 JAPAN