



INSTALLATION AND SERVICE MANUAL

High Intensity Gas Fired Infrared Unit Heaters

Model MHR, Control Codes 47, 48, 97, 98, 27, 67, 38 and 88



INSTRUCTIONS APPLY TO:

- Installation
- Operation
- Maintenance

▲ WARNING ▲

Improper installation, adjustment, alteration, service or maintenance can cause property damage, injury or death. Read the installation, operating, and service/maintenance instructions thoroughly before installing or servicing this equipment.

▲ WARNING ▲

Gas-fired appliances are not designed for use in hazardous atmospheres containing flammable vapors or combustible dust, or atmospheres containing chlorinated or halogenated hydrocarbons.

FOR YOUR SAFETY

The use and storage of gasoline or other flammable vapors and liquids in the vicinity of this appliance is hazardous.

FOR YOUR SAFETY

If you smell gas:

1. Open windows.
2. Do not touch electrical switches.
3. Extinguish any open flame.
4. Immediately call your gas supplier.
5. If gas supplier cannot be reached, call fire department.

FOR INDOOR INSTALLATION ONLY. NOT FOR RESIDENTIAL USE.

These heaters must NOT be used in the following applications:

- Enclosed swimming pool areas.
- Areas with contaminated atmospheres.
- Areas requiring explosion-proof equipment.
- Process heating applications.

HAZARD INTENSITY LEVELS

- **DANGER:** Failure to comply will result in severe personal injury or death and property damage.
- **WARNING:** Failure to comply could result in severe personal injury or death and/or property damage.
- **CAUTION:** Failure to comply could result in minor personal injury and/or property damage.

CONTENTS

Section	Page
1. General Information and Installation Codes.....	2
2. Canadian Codes.....	3
3. Unpacking.....	4
4. Restrictions.....	4
5. Basic Dimensions.....	4
6. Clearance to Combustibles.....	5
7. Mounting Considerations.....	6
8. Ventilation Requirements.....	7
9. Gas Supply.....	7
10. Electrical Supply.....	8
11. Installation.....	10
12. Ignition, Operation and Shutdown.....	12
13. Gas Pressure and Gas Conversion.....	16
14. Maintenance.....	16
15. Accessories.....	17
16. Replacement Parts.....	17
17. Troubleshooting.....	18
18. Model Numbers.....	19

ATTENTION

Mount a copy of these instructions adjacent to the heater and retain a copy for future reference.

1. GENERAL INFORMATION AND INSTALLATION CODES

▲ **WARNING** ▲

- These infrared heaters are the unvented type. Products of combustion generated are released into the space being heated. When operating heaters, air for ventilation **MUST** be provided as per the Ventilation Requirements section.

GENERAL INFORMATION

- These heaters are CSA International Designed Certified and manufactured in compliance with the Standard for Gas-Fired High-Intensity Infrared Heaters, ANSI Z83.19 / CSA 2.35-latest edition, approved by the American National Standards Institute (ANSI) and the Canadian Standards Association (CSA) for indoor installation only.
- These heaters are approved for commercial and industrial installation only.
- **These heaters MUST be installed and serviced ONLY by trained and qualified gas installation and service personnel. The installing contractor must be familiar with all the various requirements and is responsible for installing each heater in compliance with these instructions and all applicable codes of all authorities having jurisdiction, local, state, provincial and national.**
- These heaters should not be installed in buildings with uninsulated metal roof decks. Uninsulated metal roof decks will cause condensation of water vapor (contained in the heater flue gas) on the inside of the building. Metal roof decks must be insulated using built-up insulation and roofing on the exterior or, inside insulation that is not permeable to water vapor. Interior insulation that is permeable to water vapor must be completely sealed with a vapor barrier.

HIGH ALTITUDE

- These heaters are manufactured for use at the specific altitude range stated on the heater serial plate. Do not install heater if it is not rated for the correct altitude. Contact factory if in doubt.

LOCAL APPROVALS

- Single-stage heaters have been granted local approval by New York City (MEA 418-86-E).
- Single-stage heaters have been granted CE approval.

INSTALLATION CODES

- The installation must conform with local building codes or, in the absence of local codes, with the National Fuel Gas Code ANSI Z223.1 / NFPA 54-latest edition, or the Natural Gas and Propane Installation Code, CSA B149.1.
- In locations used for the storage of combustible materials, signs shall be posted to specify the maximum permissible stacking height to maintain required clearances from the heater to the combustibles.
- Natural or mechanical means shall be provided to supply and exhaust [combustion and ventilation air at a rate of] at least [4 CFM per 1000 BTUH] $4 \text{ ft}^3/\text{min}/1000 \text{ Btu/hr}$ ($0.38 \text{ m}^3/\text{min}/\text{kW}$) input of installed heaters.
- Exhaust openings for removing flue products shall be above the level of the heaters.
- If an external electrical source is utilized, the heater, when installed, must be electrically grounded in accordance with the National Electric Code, ANSI / NFPA 70-latest edition.
- All NFPA publications are available from the National Fire Protection Association, Batterymarch Park, Quincy, Massachusetts, MA 02269 USA.

AIRCRAFT HANGARS

- These overhead heaters are suitable for use in aircraft hangars when installed in accordance with the Standard for Aircraft Hangars, NFPA 409-latest edition, and are so marked.
- In aircraft storage and servicing areas, heaters shall be installed at least 3 m (10 ft) above the upper surface of wings or of the engine enclosures of the highest aircraft that might be housed in the hangar. The measurement shall be made from the wing or engine enclosure, whichever is higher from the floor, to the bottom of the heater.
- In shops, offices, and other sections of the aircraft hangars communicating with the aircraft storage or servicing areas, the bottom of the heaters shall be installed not less than 2.4 m (8 ft) above the floor.
- In all hangars, suspended or elevated heaters shall be located in spaces where they shall not be subject to injury by aircraft, cranes, movable scaffolding, or other objects. Provisions shall be made to ensure accessibility to suspended heaters for recurrent maintenance purposes.

REPAIR GARAGES

- These overhead heaters are suitable for use in repair garages when installed in accordance with the Standard for Motor Fuel Dispensing Facilities and Repair Garages, NFPA 30A-latest edition (formerly Standard for Repair Garages, NFPA 88B), and are so marked.
- Heat producing appliances using gas or oil fuel listed for use in garages shall be permitted to be installed in lubrication rooms, service rooms, or fuel dispensing areas where Class I liquids are dispensed or transferred, provided the equipment is installed at least 2.4m (8 ft) above the floor.

PARKING STRUCTURES

- These overhead heaters are suitable for use in parking structures when installed in accordance with the Standard for Parking Structures, NFPA 88A-latest edition, and are so marked.
- All flames associated with heating equipment shall be located a minimum of 500 mm (18 in.) below the floor-ceiling assembly or 500 mm (18 in.) above the floor.

▲ **WARNING** ▲

- **An overhead heater should be installed so that the minimum clearances marked on the heater will be maintained from vehicles parked below the heater. (ANSI Z83.19, section 1.25.3.d.)**

2. CANADIAN CODES

- The information on this page applies specifically to installations in Canada.

INSTALLATION CODES

- These heaters are CSA International Designed Certified and manufactured in compliance with the Standard for Gas-Fired High-Intensity Infrared Heaters, CAN/CSA 2.35-latest edition, approved by the Canadian Standards Association (CSA), for indoor installation only.
- The installation must conform with local building codes or, in the absence of local codes, with the current Canadian Natural Gas and Propane Installation Code, CAN/CSA B149.1-latest edition. Canadian authorities having jurisdiction should be consulted, before installations are made, to verify local codes and installation procedures.
- The heater shall be protected against physical damage.
- The heater shall not be installed in any location where a flammable vapour, combustible dust or fibres, or an explosive mixture is present.
- The heater shall not be installed in a residential or care or detention occupancy building.
- The heater shall be provided with mechanical ventilation for combustion and ventilation air
 - (1) that is so located that products of combustion from each heater are effectively removed outdoors;
 - (2) that has a ventilation volume of at least [3 CFM per 1000 BTUH] 300 cfm ($142 \text{ dm}^3/\text{s}$) for each 100 000 Btuh (30kW) input or fraction thereof; and
 - (3) is sufficient to maintain the level of carbon dioxide at less than 5000 ppm measured 6 ft (2m) above the work area.
- The heater shall have the ventilation system so interlocked that any reduction of the volume of airflow required in the above note for a heater or group of heaters will cause the shutdown of that heater or group of heaters.
- The heater shall not be installed in an exit passageway or stairway within 8 ft (2.5m) measured horizontally from an exit door.
- The heater shall be provided with clearance from combustible materials as certified and indicated on the heater.
- If an external electrical source is utilized, the heater, when installed, must be electrically grounded in accordance with the Canadian Electric Code, CAN/CSA C22.1-latest edition.

AIRCRAFT HANGARS

- These overhead heaters are suitable for use in aircraft hangars when installed in accordance with the Canadian Natural Gas and Propane Installation Code, CAN/CSA B149.1-latest edition.
- A heater located in an aircraft storage or servicing area shall be installed so that no portion of an aircraft that can occupy the area that is within the clearance to combustible material, as marked on the heater rating plate.
- When an infrared heater is installed in either a repair or shop area that communicates with an aircraft hangar, the minimum clearance from the floor to the infrared heater shall be 8 ft (2.4m).
- An infrared heater shall not be located in an area of an aircraft hangar where it can be subjected to physical damage by aircraft, cranes, movable scaffolding, or other objects.

GARAGES

- These overhead heaters are suitable for use in garages when installed in accordance with the Canadian Natural Gas and Propane Installation Code, CAN/CSA B149.1-latest edition.
- The minimum clearance from the radiant face of the infrared heater to the upper surface of the highest vehicle shall not be less than the certified clearance from combustible material as indicated on the heater [installed in a garage or a car wash]. Provision shall be made to maintain these minimum specified clearances by an interlock that shuts off the gas supply until the required clearances have been re-established, a protective bar, or a device that provides a warning when the clearances are not being maintained.
- Where an infrared heater is installed in a garage and the clearance from combustible material cannot be maintained when the vehicle is raised on a hoist, an electrical interlock shall be provided to shut off the burner and prevent its operation until the required clearance has been re-established.

▲ **WARNING** ▲

- **An overhead heater should be installed so that the minimum clearances marked on the heater will be maintained from vehicles parked below the heater. (CAN/CSA 2.35, section 1.25.3.d.)**

3. UNPACKING

- This heater is completely assembled, 100% factory tested, inspected prior to shipment, and ready for installation.
- Review the transportation company's bill of lading and/or freight bill. Observe and confirm the number of packages received agrees with the quantity indicated on the documents. If there is any disagreement or any part of the shipment is visibly damaged, note the nature and extent of it on the documents. If damage is discovered after delivery, leave the damaged material in the original shipping container(s) and immediately call the transportation company and request for an inspection to be made.

4. RESTRICTIONS

- Use for process heating applications **VOIDS** the warranty and CSA design certification.
- These heaters are **RESTRICTED** from use for the following applications, which will also **VOID** the warranty and CSA design certification.

WARRANTY VOID IF UNIT IS...

- Used in atmospheres containing flammable vapors or atmospheres containing chlorinated or halogenated hydrocarbons or atmospheres containing explosive dusts.
- Installed without proper clearance to combustible materials or in a location where the heater controls can be subjected to ambient temperatures above 150°F (66°C) or below -40°F (-40°C).
- Installed at angles not approved for the model.
- Installed for other than space heating applications.
- Installed for residential use. **(HEATER IS NOT FOR RESIDENTIAL USE.)**
- Installed outdoors.
- Installed in enclosed swimming pool areas.
- Altered. Units are completely factory assembled and tested.

5. BASIC DIMENSIONS

FIGURE 1 – LENGTHS, WIDTH AND HEIGHT

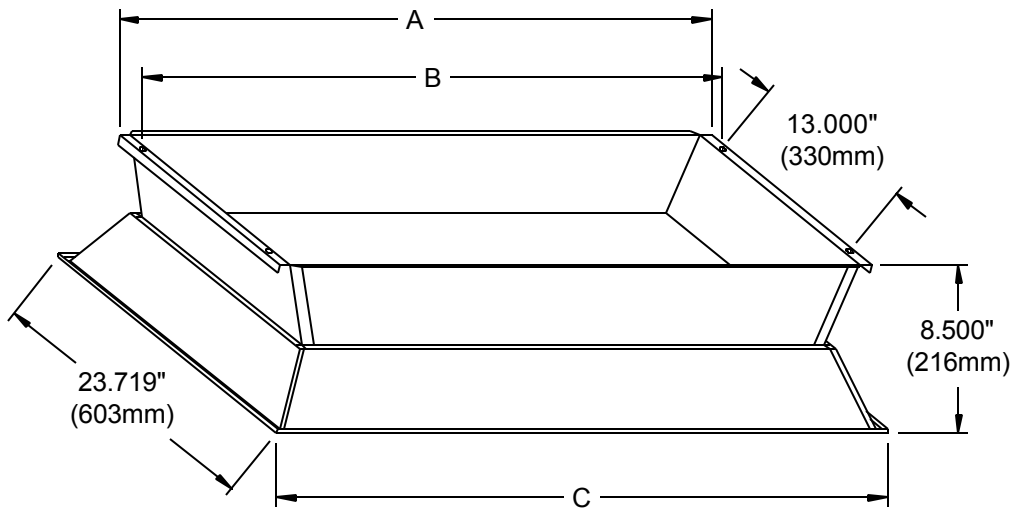

Note: Four (4) mounting holes .375" (9.5mm) diameter for balanced suspension are located by dimensions B x 13.000" (330mm).

LEGEND

MODEL	A	B	C
<u>MBTUH</u> <u>(kW)</u>	<u>inches</u> <u>(mm)</u>	<u>inches</u> <u>(mm)</u>	<u>inches</u> <u>(mm)</u>
30 – 60 (9-18)	15.312 (389)	14.625 (372)	16.625 (422)
70 – 100 (21-29) *90/45 *(26/13) *100/50 *(29/15)	23.938 (608)	23.250 (591)	25.250 (641)
110 – 160N (32-47N) *120/80 *(35/23) *150/100 *(44/29)	32.563 (827)	31.875 (810)	33.875 (860)
160L – 200 (47L-59) *160/80 *(47/23) *200/100 *(59/29)	41.188 (1046)	40.500 (1029)	42.500 (1080)

* = 2-stage models, L = LP/propane gas, N = Natural gas

6. CLEARANCE TO COMBUSTIBLES

▲ WARNING ▲

- Single or multi-heater placement must be such that continuous operation of the heater or heaters will not cause combustible materials or materials in storage to attain a temperature in excess of 150°F (66°C).
- Under no circumstances should this heater be installed in a combustible atmosphere or in a location where the heater controls can be subjected to ambient temperature in excess of 150°F (66°C).
- These heaters **MUST** be mounted with minimum clearances between the combustion surface and combustible materials. See Table 1, Clearance to Combustibles Requirements and Figure 2, Clearance to Combustibles Diagrams.

TABLE 1. CLEARANCE TO COMBUSTIBLES REQUIREMENTS

NATURAL GAS MODELS MBTUH = 1000 Btu/hour	30–60 ^{1,2}	70–100 ³ *100/50 ³	110–150 *150/100	160 ³	175–200 *200/100
PROPANE GAS MODELS MBTUH = 1000 Btu/hour	50	70–90 ³ *90/45 ³	120 *120/80	160 ³ *160/80 ³	
CLEARANCE TO COMBUSTIBLES	inches (cm)	inches (cm)	inches (cm)	inches (cm)	inches (cm)
SIDE OF HEATER (A)	30 (76)	36 (91)	46 (117)	48 (122)	48 (122)
BACK OF HEATER (B)	30 (76)	30 (76)	33 (84)	33 (84)	33 (84)
TOP OF HEATER (C):					
- Mounting Angle 5-29° (C)	60 (152)	62 (157)	64 (163)	68 (173)	68 (173)
- Mounting Angle 30° ONLY (C)	48 (122)	50 (127)	58 (147)	68 (173)	68 (173)
- w/ Optional Heat Deflector 5-30° (C)	34 (86)	38 (97)	na	na	na
BELOW HEATER (D):					
- Standard Reflector (D)	80 (203)	105 (267)	125 (318)	140 (356)	140 (356)
- w/ Optional Parabolic Reflector (D)	110 (279)	135 (343)	165 (419)	180 (457)	180 (457)
NATURAL GAS MODELS (Kilowatts)	(9-18) ^{1,2}	(21-29) ³ *(29/15) ³	(32-44) *(44/29)	(47) ³	(51-59) *(59/29)
PROPANE GAS MODELS (Kilowatts)	(15)	(21-26) ³ *(26/13) ³	(35) *(35/23)	(47) ³ *(47/23) ³	

Notes: 1 = 30 and 35 MBTUH (9 and 10kW) models not available in Canada; 2 = 60 MBTUH (18kW) models require wire grid in Canada; 3 = See Table 4, Allowable Mounting Angles, in the Installation section. na = Not available. (A), (B), (C), and (D) refer to Figure 2, Clearance to Combustibles Diagrams. * = 2-stage models.

FIGURE 2 – CLEARANCE TO COMBUSTIBLES DIAGRAMS

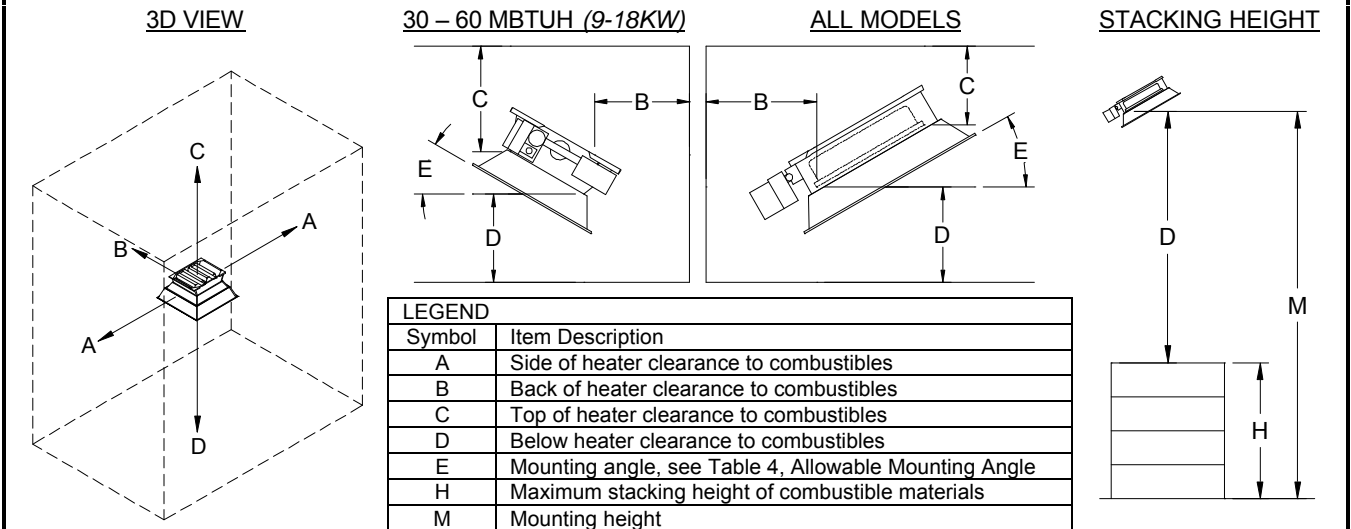

- In locations used for the storage of combustible materials, signs shall be posted to specify the maximum permissible stacking height to maintain required clearances from the heater to combustibles. (ANSI Z233.1/NFPA 54)
- The stated clearance to combustibles represents a surface temperature of 90 °F (50°C) above room temperature. Building materials with low heat tolerance (such as plastic, vinyl siding, canvas, tri-ply, etc.) may be subject to degradation at lower temperatures. It is the installer's responsibility to assure that adjacent materials are protected from degradation. (ANSI Z83.19)
- It is recommended more distance than the minimum clearance be maintained above the unit whether or not the construction is combustible to reduce and/or eliminate hot spots and possible staining of painted ceiling surfaces.
- If the unit must be close to the roof or ceiling, interpose a non-combustible baffle (twice the size of the reflector) between the unit and the roof or ceiling. Allow at least 2" (5cm) between the roof or ceiling and the non-combustible baffle. Allow at least 12" (31cm) between the non-combustible baffle and the top of the heater.

7. MOUNTING CONSIDERATIONS

- These heaters shall be installed with clearances from combustible material as specified in the Clearance to Combustibles section.
- Heaters should also be located with respect to building construction and equipment so as to provide sufficient clearance and accessibility for servicing and cleaning.
- See Table 2, Recommended Mounting Height. A mounting height lower than the recommended mounting height may be used if personnel are not required to stay directly under the heater.
- See Table 3, Recommended Distance from a Wall for Heaters Mounted At 5°.

TABLE 2. RECOMMENDED MOUNTING HEIGHT

MODELS		With Standard Reflector AT 5°		With Standard Reflector AT 30°		With Optional Parabolic Reflector AT 5°		With Optional Parabolic Reflector AT 30°	
		feet	(m)	feet	(m)	feet	(m)	feet	(m)
30	(9)	11.0 – 13.0	(3.4 - 4.0)	10.0 – 12.0	(3.0 - 3.7)				
40	(12)	12.0 – 14.5	(3.7 - 4.4)	11.5 – 13.5	(3.5 - 4.1)				
50	(15)	13.5 – 15.5	(4.1 - 4.7)	12.5 – 14.5	(3.8 - 4.4)	15.5 – 18.5	(4.7 - 5.6)	14.0 – 17.0	(4.3 - 5.2)
60	(18)	14.5 – 16.5	(4.4 - 5.0)	13.0 – 15.0	(4.0 - 4.6)	16.0 – 20.0	(4.9 - 6.1)	15.0 – 18.0	(4.6 - 5.5)
70	(21)	15.0 – 17.0	(4.6 - 5.2)	13.5 – 15.5	(4.1 - 4.7)	17.5 – 20.5	(5.3 - 6.2)	16.0 – 19.0	(4.9 - 5.8)
80	(23)	15.5 – 18.0	(4.7 - 5.5)	14.0 – 16.5	(4.3 - 5.0)	18.5 – 21.5	(5.6 - 6.6)	17.0 – 20.0	(5.2 - 6.1)
90	(27)	16.0 – 18.5	(4.9 - 5.6)	14.5 – 17.0	(4.4 - 5.2)	19.5 – 22.5	(5.9 - 6.9)	17.5 – 20.5	(5.3 - 6.2)
*90/45	*(26/13)								
100	(29)	17.0 – 19.5	(5.2 - 5.9)	15.0 – 17.5	(4.6 - 5.3)	20.5 – 23.5	(6.2 - 7.2)	18.5 – 21.5	(5.6 - 6.6)
*100/50	*(29/15)								
110	(32)	17.0 – 20.0	(5.2 - 6.1)	15.0 – 18.0	(4.6 - 5.5)	21.0 – 24.5	(6.4 - 7.5)	19.0 – 22.0	(5.8 - 6.7)
120	(35)	17.5 – 21.0	(5.3 - 6.4)	15.5 – 18.5	(4.7 - 5.6)	21.5 – 25.0	(6.6 - 7.6)	20.0 – 23.0	(6.1 - 7.0)
*120/80	*(35/23)								
130	(38)	18.0 – 21.0	(5.5 - 6.4)	16.0 – 19.0	(4.9 - 5.8)	22.5 – 26.0	(6.9 - 7.9)	20.5 – 23.5	(6.2 - 7.2)
150	(44)	18.5 – 22.5	(5.6 - 6.9)	16.5 – 20.0	(5.0 - 6.1)	24.0 – 27.5	(7.3 - 8.4)	21.5 – 24.5	(6.6 - 7.5)
*150/100	*(44/29)								
160	(47)	19.0 – 23.0	(5.8 - 7.0)	17.0 – 20.5	(5.2 - 6.2)	25.0 – 28.5	(7.7 - 8.7)	22.5 – 25.5	(6.9 - 7.8)
*160/80	*(47/23)								
175	(51)	19.5 – 23.5	(5.9 - 7.2)	17.5 – 21.0	(5.3 - 6.4)	25.5 – 29.0	(7.8 - 8.8)	23.0 – 26.5	(7.0 - 8.1)
200	(59)	20.5 – 25.0	(6.2 - 7.6)	18.5 – 22.5	(5.6 - 6.9)	27.0 – 31.0	(8.2 - 9.4)	24.5 – 28.0	(7.5 - 8.5)
*200/100	*(59/29)								

* = 2-stage models

TABLE 3. RECOMMENDED DISTANCE FROM A WALL FOR HEATERS MOUNTED AT 5°

MODELS		With Standard Reflector		With Optional Parabolic Reflector		Maximum Distance Between Heater Rows	
MBTUH	(kW)	feet	(m)	feet	(m)	feet	(m)
30 – 40	(9-12)	8	(2.4)	5	(1.5)	90	(27.4)
45 – 60	(13-18)	12	(3.7)	9	(2.7)	100	(30.5)
70 – 75	(21-22)	14	(4.3)	11	(3.4)	105	(32.0)
80 – 100	(23-29)	16	(4.9)	12	(3.7)	110	(33.5)
*90/45	*(26/13)						
*100/50	*(29/14)						
110 – 125	(32-37)	18	(5.5)	14	(4.3)	115	(35.1)
*120/80	*(35/23)						
130 – 150	(38-44)	20	(6.1)	15	(4.6)	120	(36.6)
*150/100	*(44/29)						
160 – 200	(47-59)	24	(7.3)	20	(6.1)	130	(39.6)
*160/80	*(47/23)						
*200/100	*(59/29)						

* = 2-stage models

8. VENTILATION REQUIREMENTS

▲ WARNING ▲

- **Insufficient ventilation may result in health problems, carbon monoxide poisoning or death. Always vent enclosed spaces and buildings according to national, state, provincial and local codes.**
- **Improper venting may result in asphyxiation, fire, explosion, injury or death.**

- These heaters must be installed and serviced **ONLY** by trained and qualified gas installation and service personnel. The installing contractor must be familiar with all the various requirements and is responsible for installing each heater in compliance with all applicable local and national codes.
- These infrared heaters are the unvented type. Products of combustion generated are released into the space being heated. Ventilation is required to dilute and remove the products of combustion and provide fresh air for efficient combustion.
- Natural or mechanical means shall be provided to supply and exhaust [air at a rate of] at least [4 CFM per 1000 BUTH] 4 ft³/min/1000 Btu/hr (0.38m³/min/kW) input of installed heaters. (ANSI Z223.1/NFPA 54, section 10.18.)
- Exhaust openings for removing flue products shall be above the level of the heaters. (ANSI Z223.1/NFPA 54, section 10.18, Infrared Heaters.)
- Air for combustion, ventilation, and dilution of flue gases shall be obtained by application of one of several methods described in the National Fuel Gas Code, ANSI Z223.1/NFPA 54, section 9.3, Air for Combustion and Ventilation.
- The ventilation technical information outlined in the current ASHRAE Handbooks should be observed when locating vents.
- Local codes may permit the use of humidistat control to remove water vapor and products of combustion. Humidistat settings will typically be in the 40-55% relative humidity range.
- For installations in **Canada** see the Canadian Codes section.

9. GAS SUPPLY

▲ WARNING ▲

- **Do not install any gas piping above the heater or in heat zones.**
- **The gas supply piping shall NOT be used to support the heater.**
- **All components of a gas supply system must be leak tested prior to placing equipment into service.**
- **NEVER test for gas leaks with an open flame. Use non-corrosive leak detecting solution.**

CAUTION

- **Isolate heater from gas supply line during high-pressure leak testing of gas supply piping.**
- All gas piping must be installed according to local codes and/or the National Fuel Gas Code, ANSI Z223.1 / NFPA 54-latest edition. Use new clean pipe. Inspect and clean out any chips or debris before installing the pipe and fittings.
- Piping joint compound must be resistant to the action of liquefied petroleum (LP) gases.
- Piping must have a drip leg trap 6" (15 cm) long at the inlet connection. (C)
- A first stage pressure regulator is required when gas supply pressure exceeds 14" (35cm) **water column (WC)**. When required, be sure this regulator is installed with the arrow indicating gas flow pointing in the proper direction. (E)
- An over-pressure protection device (OPD) may be required in certain jurisdictions.
- Install a 1/8" (3.2mm) **National Pipe Thread (NPT)** plugged tap, accessible for test gauge connection, immediately upstream of the gas supply connection to the heater. (F)
- An agency approved flexible gas connector may only be used if permitted by local code. (G)
- Always use two wrenches when mating pipe connections to the heater. Excessive torque on the heater manifold may misalign gas orifices leading to heater malfunction.
- Do not subject gas pressure regulators, flex connectors and gas cocks on the heater to test pressure over 14" (35cm) **water column (WC)** while checking for piping leaks.
- All piping joints must be tested for gas leaks with a non-corrosive leak detecting solution.
- Purge all gas supply lines of air completely before attempting to ignite heater.
- See Figure 3, Gas Supply Piping Diagram for additional information about the above notes.

FIGURE 3 – GAS SUPPLY PIPING DIAGRAM

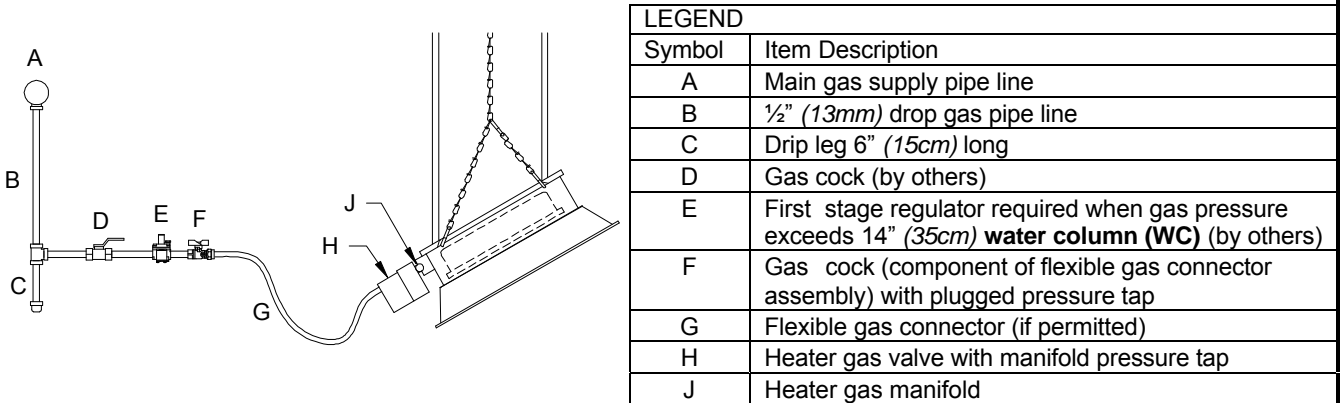

10. ELECTRICAL SUPPLY (1 OF 2)

▲ WARNING ▲

- If an external electrical source is utilized, the heater, when installed, must be electrically grounded in accordance with the National Electric Code, ANSI/NFPA 70-latest edition, or the Canadian Electrical Code, CSA C22.1-latest edition.
- Electrical supply lines shall NOT be used to support the heater.
- Do not run electrical wiring above the heater or in direct view of radiant heat.

GENERAL REQUIREMENTS FOR 120 VAC AND 24 VAC DIRECT SPARK IGNITION (DSI) MODELS

- The electrical supply wiring to the heaters using 120 VAC or 24 VAC must be installed in accordance with local codes or the National Electric Code, ANSI/NFPA 70-latest edition.
- **IMPORTANT!** The electrical power supply **MUST** be properly grounded and properly polarized. The heater controls are extremely polarity sensitive and the heater will cycle on and off erratically if the electrical supply is not wired correctly. Have a qualified electrician check that the electrical supply circuit is properly grounded and that the electrical supply polarity is correct.
- The following types of grounding are NOT permitted by code: grounding to building structures, grounding to electrical conduit, grounding to gas pipelines or grounding to water pipelines.
- Electrical power supply takeoff must be connected to a circuit breaker or to a separately fused circuit with a disconnect.
- Neither thermostats, nor switches, nor field wiring are supplied as standard equipment. When thermostats are included to control the temperature of the heated zone, they should be incorporated into the electrical circuit as shown in the respective diagrams and be positioned per the thermostat manufacturer's instructions.
- Important: In the event of an electrical fault after installation of the appliance, preliminary system checks are required to be carried out, i.e. ground continuity, polarity and resistance to ground, by a trained and qualified electrician.
- Make electrical connection to the heater as described in the Installation section.

120 VAC DIRECT SPARK IGNITION (DSI) MODELS

- Electrical supply: 120 VAC - 60 Hz - 1 Phase.
- Maximum total heater current draw: 0.14 Amps.
- Total heater power consumed: 16.8 VA (16.8W).
- 3-wire field service required.
- Field wiring having a minimum temperature rating of at least 302°F (150°C) shall be used and supply circuit wiring shall have a minimum size of 16 AWG (1.0mm²).
- Make connections as shown in Figure 4, 120 VAC DSI Heater Electrical Supply and Thermostat Wiring.

24 VAC DIRECT SPARK IGNITION (DSI) SINGLE-STAGE MODELS

- Electrical supply: 24 VAC - 60 Hz - 1 Phase.
- Maximum total heater current draw: 0.66 Amps.
- Total heater power consumed: 15.9 VA (15.9W).
- 2-wire field service required.
- Field wiring having a minimum temperature rating of at least 302°F (150°C) shall be used and supply circuit wiring shall have a minimum size of 16 AWG (1.0mm²).
- Make connections as shown in Figure 5, 24 VAC DSI Single-Stage Heater Electrical Supply and Thermostat Wiring.

24 VAC DIRECT SPARK IGNITION (DSI) 2-STAGE MODELS

- Electrical supply: 24 VAC - 60 Hz - 1 Phase.
- Maximum total heater current draw: 0.96 Amps.
- Total heater power consumed: 23.1 VA (23.1W).
- 3-wire field service required to 2-stage thermostat. 4-wire thermostat cable required from thermostat to heater.
- Field wiring use 18/4 [18 AWG (0.8mm²)/4-conductor] solid class 2 thermostat cable having a minimum insulation temperature of 140°F (60°C) between thermostat and heater. Maximum length is 125 feet (38m).
- Make connections as shown in Figure 6, 24 VAC DSI 2-Stage Heater Electrical Supply and Thermostat Wiring.

10. ELECTRICAL SUPPLY (2 OF 2)

FIGURE 4 – 120 VAC DSI HEATER ELECTRICAL SUPPLY AND THERMOSTAT WIRING*

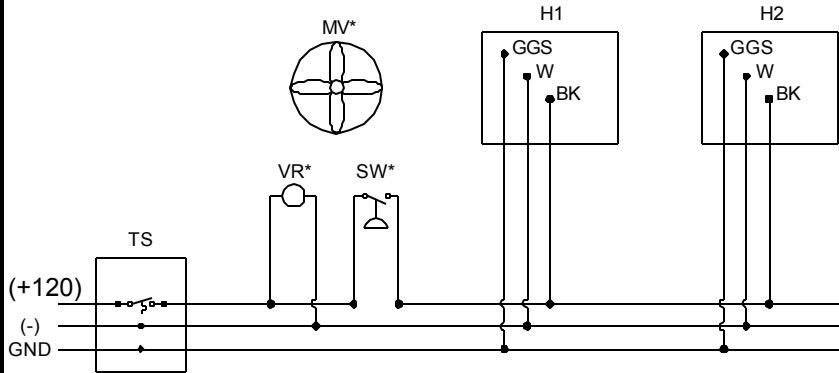

LEGEND

- (+120) = 120 VAC Supply Voltage
- (-) = Supply Neutral
- GND = Earth Ground
- MV* = Mechanical Ventilation*
- VR* = Ventilation Relay*
- SW* = Ventilation Interlock Switch*
(normally opened)
- TS = Thermostat
- H1 = Heater #1
- H2 = Heater #2
- GGS = Green Ground Screw
(inside control box)
- W = White Wire – Neutral
- BK = Black Wire – 120 VAC call for heat

- Field wiring having a minimum temperature rating of at least 302°F (150°C) shall be used and supply circuit wiring shall have a minimum size of 16 AWG (1.0mm²).
- See common notes at the bottom of the page.

FIGURE 5 – 24 VAC DSI SINGLE-STAGE HEATER ELECTRICAL SUPPLY AND THERMOSTAT WIRING*

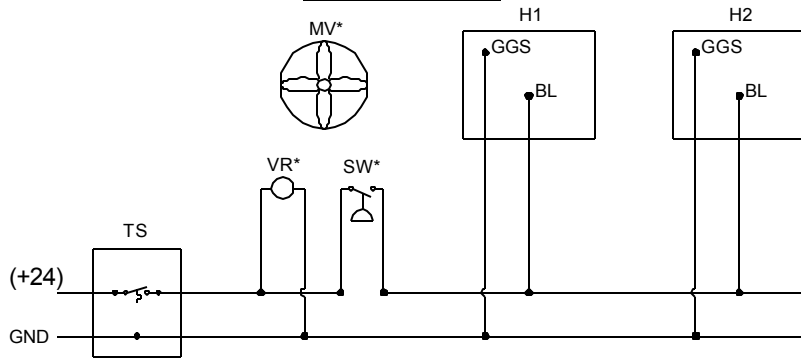

LEGEND

- (+24) = 24 VAC Supply Voltage
- GND = Earth Ground
- MV* = Mechanical Ventilation*
- VR* = Ventilation Relay*
- SW* = Ventilation Interlock Switch*
(normally opened)
- TS = Thermostat
- H1 = Heater #1
- H2 = Heater #2
- GGS = Green Ground Screw
(inside control box)
- BL = Blue Wire – 24 VAC call for heat

- Field wiring having a minimum temperature rating of at least 302°F (150°C) shall be used and supply circuit wiring shall have a minimum size of 16 AWG (1.0mm²).
- See common notes at the bottom of the page.

FIGURE 6 – 24 VAC DSI 2-STAGE HEATER ELECTRICAL SUPPLY AND THERMOSTAT WIRING*

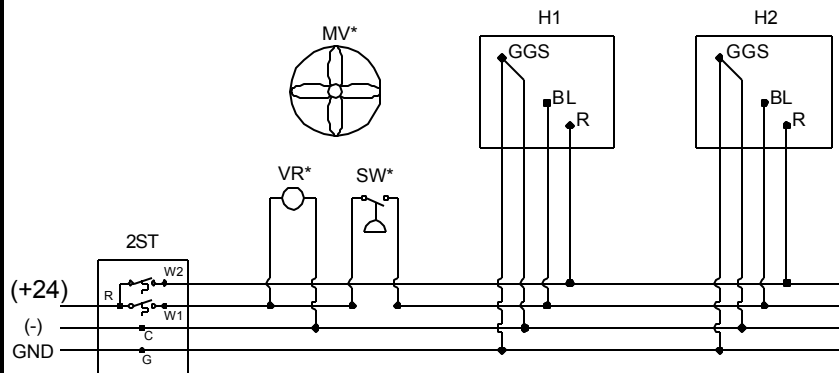

LEGEND

- (+24) = 24VAC Supply Voltage
- (-) = Supply Neutral
- GND = Earth Ground
- MV* = Mechanical Ventilation*
- VR* = Ventilation Relay*
- SW* = Ventilation Interlock Switch*
(normally opened)
- 2ST = 2-Stage Thermostat
- H1 = Heater #1
- H2 = Heater #2
- GGS = Green Ground Screw
(inside control box)
- BL = Blue Wire – 24 VAC call for
LOW heat
- R (on heater) = Red Wire – 24 VAC call for
HIGH heat

- Field wiring having a minimum temperature rating of at least 14°C (60°C) shall be used and supply circuit wiring shall have a minimum size of 18 AWG (0.8mm²).
- Use 18/4 solid class 2 thermostat cable between heater and thermostat with a maximum length of 125 feet (38m).
- See common notes at the bottom of the page.

COMMON NOTES FOR FIGURES 4, 5 AND 6.

- * Mechanical ventilation interlock required when all combustion air is provided by a mechanical air supply system.
- #10 ring terminal required for ground service conductor (by others) to attach to green ground screw on heater.
- The heater control is extremely polarity sensitive and the heater will cycle on and off erratically if the electrical supply is not wired correctly. Have a qualified electrician check that the electrical supply circuit is properly grounded and that the electrical supply polarity is correct.
- All components purchased separately. All wiring provided by others.

11. INSTALLATION (1 OF 2)

- Before installing heater, check the supporting structure to determine it has sufficient load carrying capacity to support the weight.
- The heater shall be supported independent of gas and electric supply lines.
- Hangers and brackets shall be of noncombustible material.
- The heater should be supported by chains or drop rods or brackets fixed to vertical surfaces, which have been previously installed.
- The specified clearance to combustible materials must be maintained. See Clearance to Combustibles section.
- Heaters mounting angle must be within the range allowed as listed in Table 4, Allowable Mounting Angles.

TABLE 4. ALLOWABLE MOUNTING ANGLES

SINGLE-STAGE HEATERS				*2-STAGE HEATERS					
MODEL		NET WEIGHT		ALLOWABLE MOUNTING ANGLE RANGE	MODEL		NET WEIGHT		ALLOWABLE MOUNTING ANGLE RANGE
MBTUH	(kW)	lbs.	(kg)		MBTUH	(kW)	lbs.	(kg)	
30 – 60	(9-18)	24	(11)	5° – 30°	*90/45	*(26/13)	42	(19)	5° – 30°
70 – 100	(21-29)	34	(16)	5° – 30°	*100/50	*(29/15)	42	(19)	5° – 30°
110 – 150	(32-44)	44	(20)	5° – 30°	*120/80	*(35/23)	53	(23)	5° – 30°
160	(47)	56	(26)	5° – 30°	*150/100	*(44/29)	53	(23)	5° – 30°
175 – 200	(51-59)	56	(26)	5° – 30°	*160/80	*(47/23)	66	(30)	5° – 30°
					*200/100	*(59/29)	66	(30)	5° – 30°

- **DO NOT ANGLE HEATERS MORE THAN 30°.**
- These heaters may be mounted rigidly with 3/8" (10mm) all thread rigid mount hangers or they may be suspended with chain and S-hooks. Local codes may require rigid mounting.
- Check local codes for mounting requirements and permission to use flexible gas connectors. It is recommended that either the gas connection piping or the mounting be flexible to prevent fatigue failure of the gas connection from vibration or thermal expansion.
- For proper operation, the heater must be level, whether horizontal or angle mounted. When angle mounted, all models must be installed with the gas manifold located on the low end. See Figure 7, Typical Heater Mounting, Chain or Rigid.

FIGURE 7 – TYPICAL HEATER MOUNTING, CHAIN OR RIGID

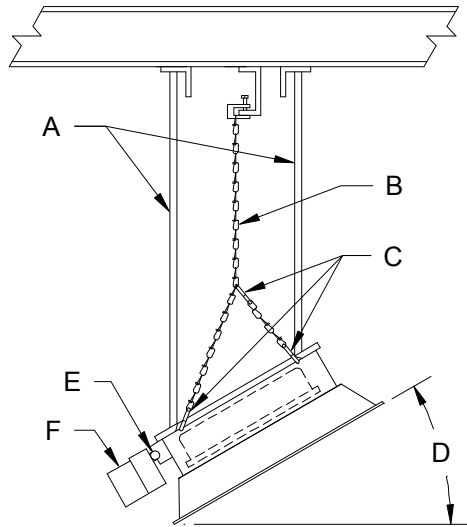

- Overhead structure and field connections must be adequate to support heater weight.
- Gas and electrical supply lines must not cross over top of heater or in the path of flue products.

LEGEND	
Symbol	Item Description
A	3/8" (10mm) all thread rigid mount (used in aircraft hangars or where draft conditions may be expected)
B	1/0 Tenso chain mounting
C	S-hooks: 1/4" (6.3mm) diameter wire (Crimp all S-hooks closed.)
D	Mounting angle, see Table 4, Allowable Mounting Angles
E	Heater gas manifold must be horizontal along the low side of the heater when angle mounting
F	Heater gas valve

- **Under no circumstances should either the gas or electrical supply lines to the unit be used to provide support in suspension. Do not run any gas or electric lines above or below the heater or near the path of the flue products.**
- Heaters located in an aircraft hangar or near overhead doors should be rigidly mounted to prevent swinging. The installer is responsible for the type of suspension used for the heater.
- If permissible by local code, it is recommended that these heaters be suspended with chain and S-hooks, See Figure 8, Chain Hanging Arrangement. Chain with 200# (91kg) working load (1/0 Tenso) is recommended. S-hooks must be a minimum of 1/4" (6.3mm) diameter wire (Chicago Hardware #5 or equal) and must be crimped closed after installation.
- See Figure 9, Optional Heater Mounting [30 – 60 MBTUH (9-18kW) Models Only] for a mounting option limited to models with only one burner.

11. INSTALLATION (2 OF 2)

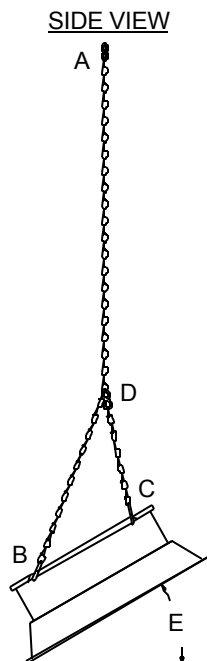
FIGURE 8 – CHAIN HANGING ARRANGEMENT

INSTRUCTIONS FOR USING OPTIONAL CHAIN KITS

1. Securely attach long chains to overhead building structure with S-hooks (A).
2. Attach the other end of the long chains to the back of the heater with S-hooks (B).
3. Attach one end of the 11" (28cm) short chains to the front of the heater with S-hooks (C).
4. Attach the other end of the short chains to the long chains with S-hook (D) by placing the S-hooks (D) in a loop of the long chain.
5. Check heater mounting angle (E). Adjust heater mounting angle (E) by moving S-hooks (D) of the short chain along the length of the long chain.
6. Check to make sure heater is level.
7. Crimp all S-hooks closed (A, B, C and D).

LEGEND

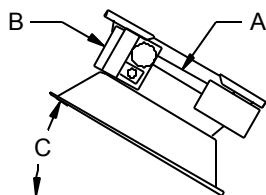
Symbol	Item Description
A	S-hook of long chain connected to overhead building structure mounting hardware
A – B	55" (140cm) long chain with S-hooks attached to each end
B	S-hook of long chain connected to back of heater
C	S-hook of short chain connected to front of heater
C – D	11" (28cm) short chain with S-hooks attached to each end
D	S-hook of short chain connected to a link of the long chain
E	Mounting Angle, see Table 4, Allowable Mounting Angles

FIGURE 9 – OPTIONAL HEATER MOUNTING [30 – 60 MBTUH (9-18kW) MODELS ONLY]

- 30 – 60 MBTUH (9-18kW) models ONLY have the option of mounting with the gas manifold (A) angled upward. ONLY in this case, the gas valve (B) MUST be toward the high side.

LEGEND

Symbol	Item Description
A	Gas Manifold
B	Gas Valve
C	Mounting Angle, see Table 4, Allowable Mounting Angles

- The heater should be raised and suspended in accordance with the preceding instructions in this section.
- Connect heater to the gas supply in accordance with the Gas Supply section.
- The heater controls are extremely polarity sensitive and will not operate properly if the electrical supply is not wired correctly.
- Connect heater to the electrical supply in accordance with the following instructions.

120VAC DIRECT SPARK IGNITION (DSI) MODELS

- Connect the electrical supply wiring as specified in the Electrical Supply section to the heater wiring shown in figures in the Ignition and Operation section. Connect incoming thermostat wires to the heater as follows:
 - Green wire with #10 ring terminal (ground) - to the heater's green ground screw inside the control box.
 - White wire (neutral) - to the heater's white wire at the control box.
 - Black wire (120 VAC from thermostat) - to the heater's black wire at the control box.

24VAC SINGLE-STAGE DIRECT SPARK IGNITION (DSI) MODELS

- Connect the electrical supply wiring as specified in the Electrical Supply section to the heater wiring shown in figures in the Ignition and Operation section. Connect incoming thermostat wires to the heater as follows:
 - Green wire with #10 ring terminal (ground) - to the heater's green ground screw inside the control box.
 - Blue wire (24 VAC from thermostat) - to the heater's blue wire at the control box.

24VAC 2-STAGE DIRECT SPARK IGNITION (DSI) MODELS

- Connect the electrical supply wiring as specified in the Electrical Supply section to the heater wiring shown in figures in the Ignition and Operation section. Connect incoming thermostat wires to the heater as follows:
 - Green wire with #10 ring terminal (ground) - to the heater's green ground screw inside the control box.
 - White wire with #10 ring terminal (neutral) - to the heater's green ground screw inside the control box.
 - Blue wire (24 VAC low-heat) - to the heater's blue wire at the control box.
 - Red wire (24 VAC high-heat) - to the heater's red wire at the control box.

12. IGNITION, OPERATION AND SHUTDOWN (1 OF 4)

LIGHTING INSTRUCTIONS FOR ALL 120 VAC AND 24 VAC DIRECT SPARK IGNITION (DSI) MODELS

Some heater models may have an ON / OFF knob on the **Combination Gas Valve (CGV)**.

1. Set gas cock (by others) to OFF position.
2. Turn electrical supply OFF.
3. Wait at least five (5) minutes.
4. Set thermostat above room temperature.
5. Set gas cock (by others) to ON position.
6. Turn electrical supply ON.
7. Set thermostat at desired temperature.
8. If heater does not light, repeat steps 1-7.

IMPORTANT: The 120 VAC and 24 VAC control systems cannot determine the presence of flame if they are not electrically grounded to the burner; they will lockout and shut off. These controls are extremely polarity sensitive. Proper grounding and proper electrical polarity are essential to the operation of these heaters.

SEQUENCE OF OPERATION FOR ALL 120 VAC AND 24 VAC DIRECT SPARK IGNITION (DSI) MODELS

1. Thermostat calls for heat. (2-stage models: low-heat or high-heat operation is determined by setpoints of the thermostat. Refer to thermostat manufacturers' instructions.)
2. Power is applied to the **Ignition Detection Control (IDC)**. 15 seconds after power is applied, a spark is developed at the electrodes and the **Combination Gas Valve (CGV)** opens for a 15-second trial-for-ignition period.
3. Burner ignites; a small DC electrical current begins flowing from sensing electrode through flame to ground.
4. IDC senses current, turns OFF spark, gas continues to flow through the CGV. (Sparking may continue for the full 15 seconds before stopping.)
5. Should the burner fail to light or flame is not detected during the first trial-for-ignition period, the CGV is de-energized and the IDC starts the 15-second inter-purge sequence before another ignition trial. After 15 seconds, the IDC begins two (2) more ignition trials. If the burner fails to light after the third trial, the IDC will de-energize the CGV and go into lockout mode.
6. On flame outage at the sensing electrode, the IDC responds and begins sparking within 0.8 seconds. A 15-second trial-for-ignition period begins to re-light the burner. If flame is re-established, normal operation resumes. (Sparking may continue for the full 15 seconds before stopping.) Should the burner fail to light or flame is not detected during the first trial-for-ignition period, the CGV is de-energized and the IDC starts the 15-second inter-purge sequence before another ignition trial. After 15 seconds, the IDC begins two (2) more ignition trials. If the burner fails to light after the third trial, the IDC will de-energize the CGV and go into lockout mode.
7. For lockout recovery, reset the thermostat below the ambient temperature or disconnect electrical power supply for 5 seconds.
 - See Figure 10, 120 VAC Direct Spark Ignition Electrical Connection Diagram, for heater wiring.
 - See Figure 11, 24 VAC Single-Stage Direct Spark Ignition Electrical Connection Diagram, for heater wiring.
 - See Figure 12, 24 VAC 2-Stage Direct Spark Ignition Electrical Connection Diagram, for heater wiring.

LIGHTING INSTRUCTIONS FOR MILLIVOLT MANUAL IGNITION MODELS

1. Set thermostat below room temperature.
2. Wait five (5) minutes.
3. Turn gas valve to PILOT position.
4. Depress gas valve knob and light pilot burner while holding down the gas valve knob for one (1) minute or until pilot flame remains lighted when knob is released.
5. Turn gas valve knob counter-clockwise to ON position.
6. Set thermostat to desired temperature.
7. If heater does not light, repeat steps 1-6.

SEQUENCE OF OPERATION FOR MILLIVOLT MANUAL IGNITION MODELS

1. Pilot is manually ignited with gas valve knob depressed in PILOT position and held until millivolt generator is heated sufficiently to keep pilot flame going (approximately 1 minute).
2. Knob is turned to ON position.
3. On call for heat, thermostat will complete circuit to gas valve as needed. Heater will ignite from standing pilot flame.
4. On pilot outage, millivolt generator will cool and interrupt circuit to gas valve. Both main and pilot gas are turned OFF automatically.
 - See Figure 13, Millivolt Manual Ignition Electrical Connection Diagram, for heater wiring.

SHUTDOWN

- To shutdown the heater for **a week or less**, switch off the electrical supply to the heater.
- To shutdown the heater for **more than one week**, switch off the electrical supply to the heater and turn off the gas supply at the gas isolation valve.

12. IGNITION, OPERATION AND SHUTDOWN (2 OF 4)

FIGURE 10 – 120 VAC DIRECT SPARK IGNITION ELECTRICAL CONNECTION DIAGRAM

120 VAC – 60 Hz – 1 Phase
 Heater Maximum Current Draw = 0.14 Amps.
 Total Heater Power Consumed = 16.8 VA

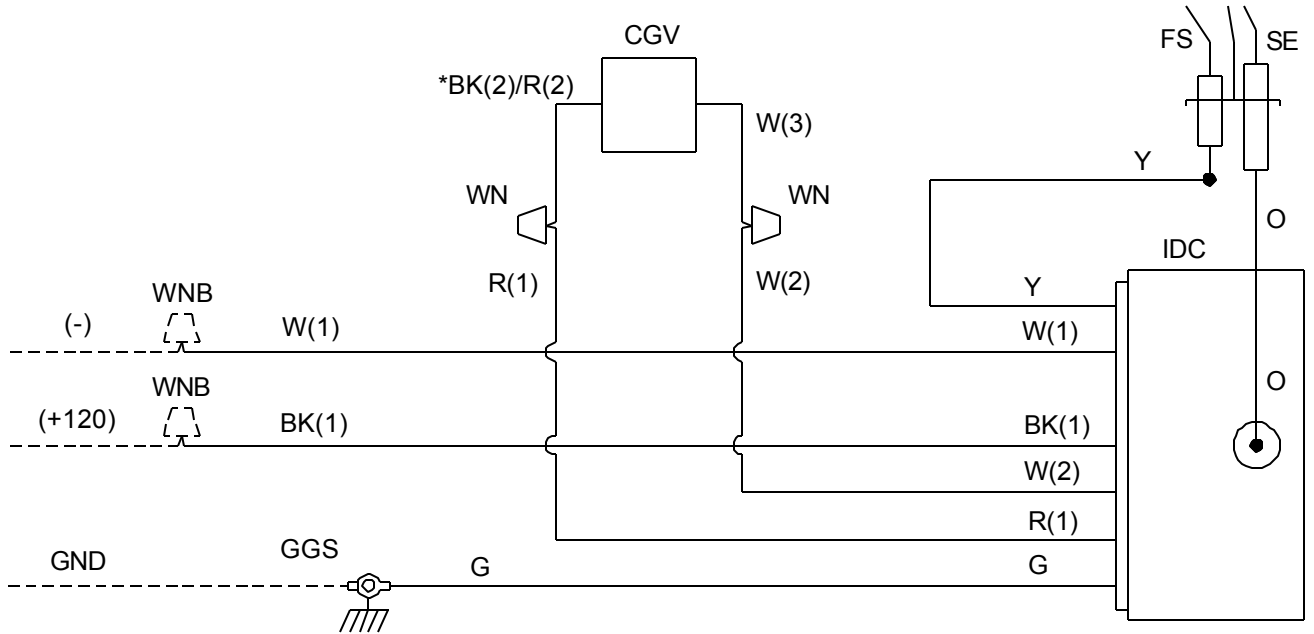

- Control is polarity sensitive.
- Others to provide and install #10 ring terminal required for ground service conductor to attach to green ground screw on heater.
- See Electrical Supply section for detailed information on electrical supply and thermostatic control.
- If any of the original wire as supplied with the appliance must be replaced, it must be replaced with wiring material having a temperature rating of at least 302°F (150°C) and a minimum size of 16 AWG (1.0mm²).

LEGEND

Function	Symbol	Item Description	Connecting Wire Color
Electrical Supply / Thermostatic Control	(+120)	120 VAC Supply (by others)	Black
	(-)	Common / Neutral (by others)	White
	GND	Ground (by others)	Green (with Ring Terminal by others)
Wiring	----	Wiring (by others)	
	WNB	Wire Nut (by others)	
	WN	Wire Nut	
Ground	GGS	Green Ground Screw Inside Control Box	Green (with Ring Terminal)
Ignition Detection Control	IDC	Ignition Detection Control	
	O	Ignition Cable to Spark Electrode	Orange
	Y	Flame Sensor Input	Yellow
	W(1)	Common / Neutral Input	White
	BK(1)	120 VAC Supply Input	Black
	W(2)	Neutral to Combination Gas Valve	White
	R(1)	120 VAC to Combination Gas Valve	Red
G	Ground	Green (with Ring Terminal)	
Spark Electrode	SE	Spark Electrode	Orange
Flame Sensor	FS	Flame Sensor	Yellow
Combination Gas Valve	CGV	Combination Gas Valve	
	*BK(2)/R(2)	120 VAC to Combination Gas Valve	Black (1 & 2-burner)/Red (3 & 4-burner)
	W(3)	Neutral to Combination Gas Valve	White

12. IGNITION, OPERATION AND SHUTDOWN (3 OF 4)

FIGURE 11 – 24 VAC SINGLE-STAGE DIRECT SPARK IGNITION ELECTRICAL CONNECTION DIAGRAM

24 VAC – 60 Hz – 1 Phase
 Heater Maximum Current Draw = 0.66 Amps.
 Total Heater Power Consumed = 15.9 VA
 Control is polarity sensitive.

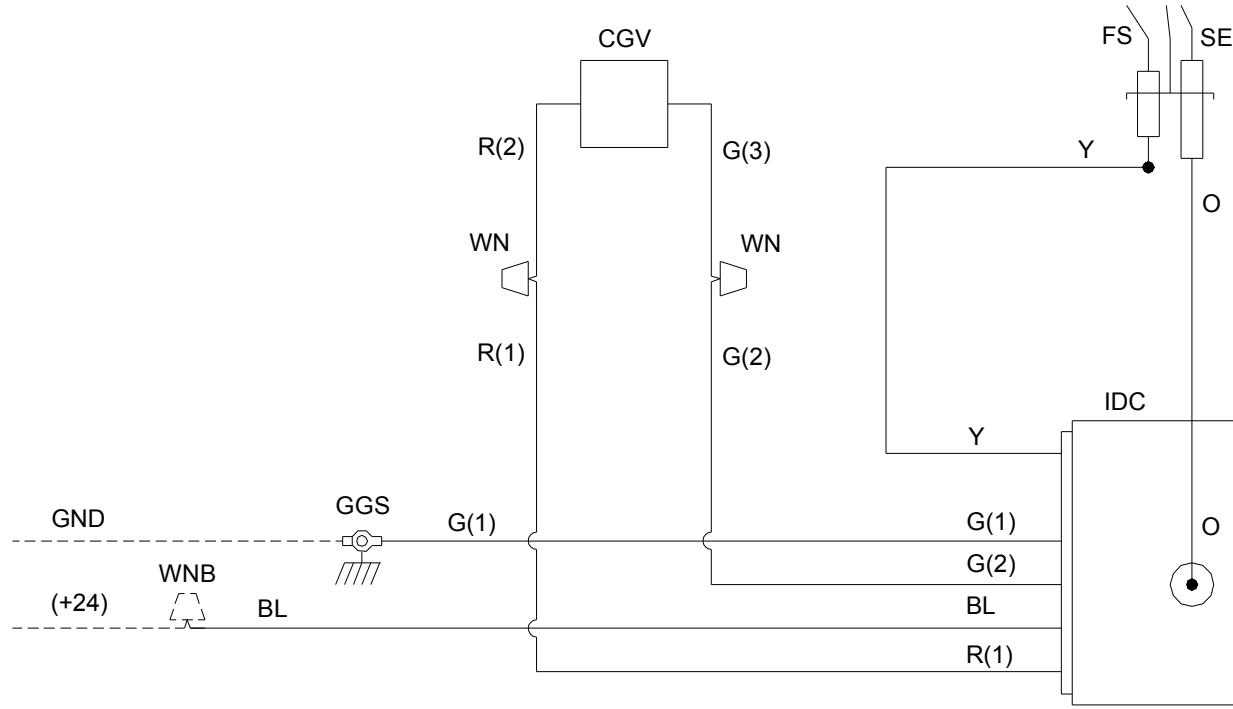

- Others to provide and install #10 ring terminal required for ground service conductor to attach to green ground screw on heater.
- See Electrical Supply section for detailed information on electrical supply and thermostatic control.
- If any of the original wire as supplied with the appliance must be replaced, it must be replaced with wiring material having a temperature rating of at least 302°F (150°C) and a minimum size of 16 AWG (1.0mm²).

LEGEND

Function	Symbol	Item Description	Connecting Wire Color
Electrical Supply / Thermostatic Control	(+24)	24 VAC Supply (by others)	Blue
	GND	Ground (by others)	Green (with Ring Terminal by others)
Wiring	----	Wiring (by others)	
	WNB	Wire Nut (by others)	
	WN	Wire Nut	
Ground	GGG	Green Ground Screw Inside Control Box	Green (with Ring Terminal)
Ignition Detection Control	IDC	Ignition Detection Control	
	O	Ignition Cable to Spark Electrode	Orange
	Y	Flame Sensor Input	Yellow
	G(1)	Ground	Green (with Ring Terminal)
	G(2)	Ground to Combination Gas Valve	Green
	BL	24 VAC Supply Input	Blue
	R(1)	24 VAC to Combination Gas Valve	Red
Spark Electrode	SE	Spark Electrode	Orange
Flame Sensor	FS	Flame Sensor	Yellow
Combination Gas Valve	CGV	Combination Gas Valve	
	R(2)	24 VAC to Combination Gas Valve	Red
	G(3)	Ground to Combination Gas Valve	Green

12. IGNITION, OPERATION AND SHUTDOWN (4 OF 4)

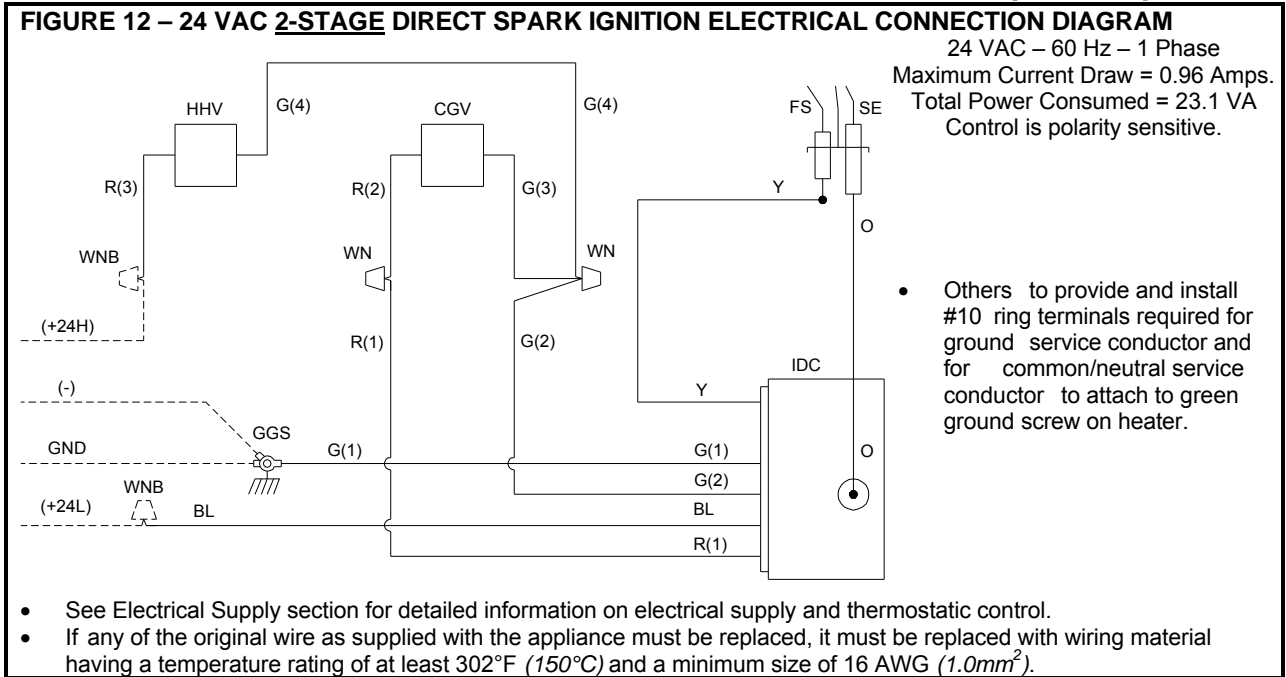

LEGEND			
Function	Symbol	Item Description	Connecting Wire Color
Electrical Supply / Thermostatic Control	(+24H)	24 VAC High Heat Supply (by others)	Red
	(+24L)	24 VAC Low Heat Supply (by others)	Blue
	(-)	Common / Neutral (by others)	White (with Ring Terminal by others)
	GND	Ground (by others)	Green (with Ring Terminal by others)
Wiring	---	Wiring (by others)	
	WNB	Wire Nut (by others)	
	WN	Wire Nut	
Ground	GGS	Green Ground Screw Inside Control Box	Green (with Ring Terminal)
Ignition Detection Control	IDC	Ignition Detection Control	
	O	Ignition Cable to Spark Electrode	Orange
	Y	Flame Sensor Input	Yellow
	G(1)	Ground	Green (with Ring Terminal)
	G(2)	Ground to Combination Gas Valve	Green
	BL	24 VAC Low Heat Supply Input	Blue
	R(1)	24 VAC to Combination Gas Valve	Red
Spark Electrode	SE	Spark Electrode	Orange
Flame Sensor	FS	Flame Sensor	Yellow
Combination Gas Valve	CGV	Combination Gas Valve	
	R(2)	24 VAC to Combination Gas Valve	Red
	G(3)	Ground to Combination Gas Valve	Green
High Heat Gas Valve	HHV	High Heat Valve	
	R(3)	24 VAC to High Heat Valve	Red
	G(4)	Ground to High Heat Valve	Green (with Ring Terminal)

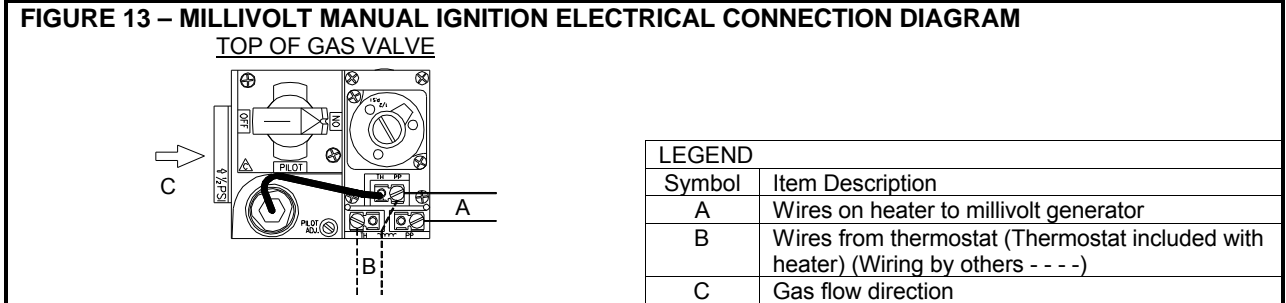

13. GAS PRESSURE AND GAS CONVERSION

GAS PRESSURE

- Whether the heater is on or off, the main gas supply line pressure must be limited to 14 inches (35cm) of **water column (WC)** (1/2 PSI). If the gas supply line pressure can go above 14" WC (35cm WC) at any time, a separate positive lockup high-pressure regulator must be used. Always check local codes for gas venting requirements for high-pressure regulators. High-pressure regulators will **NOT** turn off the flow of gas.
- The minimum gas supply line pressure measured at the inlet pressure tap of the heater regulator must, in no case, be lower than 7" WC (18cm WC) for natural gas and 11" WC (28cm WC) for LP/propane gas when this heater and **ALL** other gas burning equipment are operating at maximum capacity.
- Use a water or red oil manometer when checking gas pressures. **DO NOT USE A DIAL GAUGE.**
- See Table 5, Gas Pressure Requirements.

TABLE 5. GAS PRESSURE REQUIREMENTS

TYPE OF GAS	SUPPLY PRESSURE Water Column (WC)		MANIFOLD PRESSURE AT TAP IN VALVE Water Column (WC)
	Minimum	Maximum	
Natural	7 inches (18cm)	14 inches (35cm)	6 inches (15cm)
LP/Propane	11 inches (28cm)	14 inches (35cm)	10 inches (25cm)

- Gas pressure measurement equivalents are: 14" WC \cong 1/2 PSI \cong 35cm WC \cong 35mbar \cong 3.5kPa.
- Natural gas models are orificed for gas with a gross calorific value of 1000 BTU/cubic foot (37MJ/m³).
- LP/Propane gas models are orificed for gas with a gross calorific value of 2500 BTU/cubic foot (93MJ/m³).

GAS CONVERSION

- It is feasible to convert the type of gas or BTUH (kW) rating of a heater after it is has been installed. Identify the model number and serial number of the heater. Consult factory for proper instructions and parts. Use of parts other than those provided by the factory voids the warranty and the CSA Design Certification.

14. MAINTENANCE

- Annual maintenance should be performed as follows:

ANNUAL MAINTENANCE

1. Disconnect all power sources related to the installation and close the gas supply valve at the heater.
2. With compressed air of 20 PSI (140kPa) or less, blow off all accumulated dust and dirt.
3. Blow air over the ceramic tile (avoiding gasket material between tile) and alternately into the venturi several times in succession. Do not damage gasket material between ceramic tiles. Damaging gasket material between tiles could lead to burner flashback.

CAUTION

- **Always wear protective goggles when cleaning heaters with compressed air.**
- See Figure 14, General Heater Diagram, for the location of major components of the heater.
- See Figure 15, Direct Spark Electrode Installed, for the electrode's orientation to and correct distance from the burner assembly's ceramic tile surface.

FIGURE 14 – GENERAL HEATER DIAGRAM

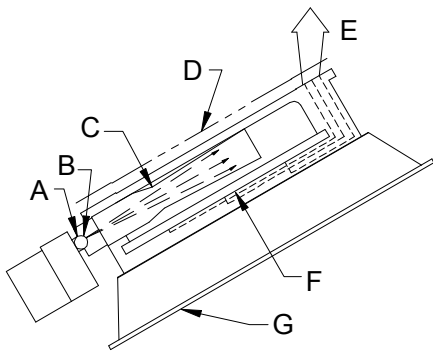

LEGEND	
Symbol	Item Description
A	Gas manifold
B	Gas orifice
C	Venturi
D	Optional heat deflector
E	Heater flue exhaust path
F	Ceramic tile surface
G	Standard reflector assembly

FIGURE 15 – DIRECT SPARK ELECTRODE INSTALLED

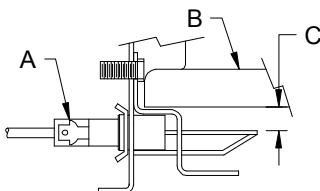

LEGEND	
Symbol	Item Description
A	Electrode
B	Burner
C	Proper installation results in 0.219" +/- 0.032" (5.6mm +/- 0.8mm) clearance from ceramic tile surface to the sparking tips of the electrode.

15. ACCESSORIES

▲ WARNING ▲

- The safe application and use of the supplied equipment is responsibility of the installer, user, owner and employer. The application of this equipment can vary greatly. For most applications and use there are available diversified product models and optional safety accessories. This equipment may be sold with or without safety accessories. The diversity of applications for this heater precludes the establishing or warranting the efficacy of safe operating conditions which may result from its' use. The installer, user, owner, employer must determine the specific safety requirements. The specific safety requirements will vary depending on the location and operating procedures. Therefore, appropriate safety accessories can only be supplied upon receipt of an order specifying them.
- The accessories listed below may be obtained from the factory. Use of some accessories may change clearance to combustibles. See Table 1. Clearance to Combustibles Requirements.

ACCESSORIES

- OPERATING CONTROLS.** Thermostats for automatic heater operation. 2-stage, programmable, night setback, line voltage, low voltage and weather resistant thermostats available.
- FLEX CONNECTORS.** Standard stainless steel or weather resistant connectors for gas supply.
- CHAIN SETS.** Factory approved pre-cut chain pre-assembled with S-hooks or uncut chain with S-hooks.
- HEAT DEFLECTORS.** Heat deflectors are available for heater models 30 – 100 MBTUH (9-29kW) to permit reduced clearance to combustibles above the heater. See Table 1, Clearance to Combustibles Requirements.
- WIRE GRIDS.** Wire grids improve heater radiant efficiency and improve heater performance in drafty areas.
- PARABOLIC REFLECTORS.** Parabolic reflectors increase the intensity of the infrared pattern below the heater while decreasing the scope of heating coverage. Parabolic reflectors increase clearance to combustibles below the heater. See Table 1, Clearance to Combustibles Requirements.
- PROTECTIVE SCREENS.** Screens protect the ceramic tile from damage caused by the impact of foreign objects. Available for all models with standard or parabolic reflectors.

16. REPLACEMENT PARTS

- The following is a list of replacement parts that may be required during the life of the heater. If it is necessary to replace those parts or other parts, please contact the manufacturer at the address noted on the back cover of this manual. Provide the serial and model numbers from the heater serial plate to assure proper parts are ordered.

PARTS

- Combination Gas Valve
- Ignition Detection Control
- Spark Electrode
- Burner (Ceramic Tile Burner Assembly)

BURNER REPLACEMENT

- A burner (Ceramic Tile Burner Assembly) can be replaced easily without taking the heater down from its mounted location. See Figure 16, Burner Replacement.

FIGURE 16 – BURNER REPLACEMENT

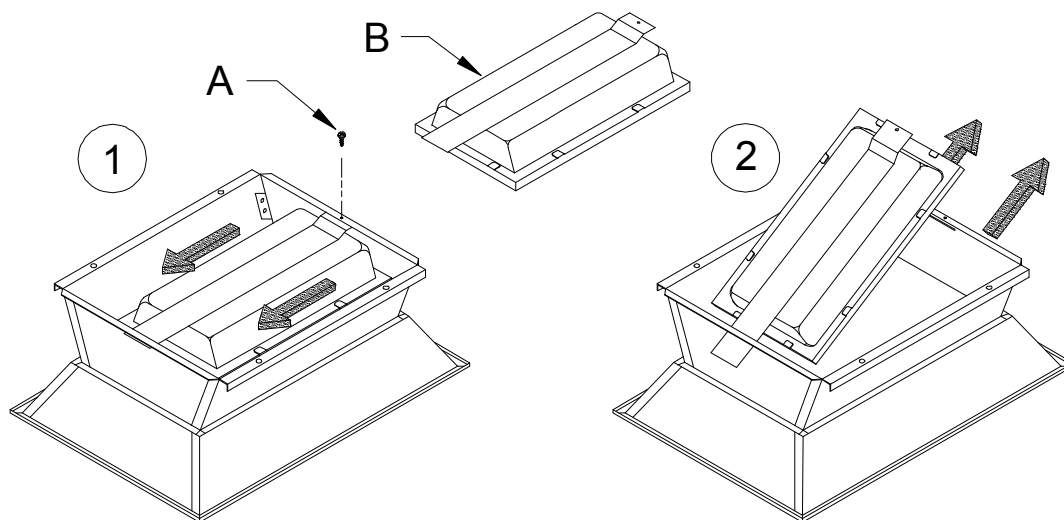

BURNER REMOVAL INSTRUCTIONS

- Step (1). Remove screw (A) and slide burner (B) backward.
 Step (2). Pull burner (B) up and outward.
 Reverse the procedure to re-install burner.

LEGEND

Symbol	Item Description
A	Screw
B	Burner (Ceramic Tile Burner Assembly)

17. TROUBLESHOOTING (1 OF 2)

SYMPTOM	POSSIBLE CAUSE	CORRECTIVE ACTION
Gas Odor	1. Gas pipe joints loose	1. Check joints with non-corrosive leak detection fluid, tighten as needed
New Installation of heaters not working	1. Heaters not isolated during high pressure leak testing of gas lines	1. Replace combination gas valves on each heater
	2. All gas lines not completely bled of air	2. Disconnect flex hose at each heater until gas is present. Connect flex hose and leak test
	3. Gas supply regulator reversed	3. Remove and install properly
	4. Electrical supply line voltage & neutral polarity reversed	4. Correct electrical supply polarity
No gas	1. Gas supply valves not opened	1. Open all manual gas supply valves
	2. Gas supply regulator sticking	2. Replace gas supply regulator
Electrical circuit closed but heater not working. (For specific control systems see Ignition and Operation section)	1. Gas supply lacking caused control system lockout	1. Verify all gas supply valves are open. Purge air from gas supply line. Turn thermostat off – wait 5 minutes, then reset thermostat
	2. Line fuse blown or tripped circuit breaker	2. Replace line fuse or reset breaker
	3. Electrical power short	3. Trace and correct short
	4. Wiring disconnected	4. Repair, see wiring diagram in Ignition section
	5. No electrical earth ground	5. Provide electrical earth ground
	6. Electrical supply line voltage & neutral polarity reversed	6. Correct electrical supply polarity
	7. Exhaust fan interlock (if used) is defective	7. Replace interlock
Direct spark fails to ignite main burner(s)	1. Combination gas valve not in the ON position	1. Turn combination gas valve to ON position
	2. Electrode wire loose	2. Reconnect wire
	3. Electrode wire broken or frayed	3. Replace electrode
	4. Electrode ceramic cracked	4. Replace electrode
	5. Electrode improperly located	5. Relocate to correct position
	6. Gas valve fails to open when power applied	6. Replace combination gas valve
	7. Supply/manifold gas pressure too low	7. See rating plate on heater and adjust pressure(s)
	8. Ignition detection control defective	8. Replace ignition detection control
Unit cycles on and off, erratic operation	1. Drafty condition	1. Shield heater / thermostat from drafts
	2. Flame sensor wire loose or damaged	2. Replace wire harness to ignition detection control
	3. No electrical earth ground	3. Provide electrical earth ground
	4. Electrical supply line voltage & neutral polarity reversed	4. Correct electrical supply polarity
	5. Heat on pilot flame sensor insufficient	5. Clean pilot, check pilot orifice and alignment
No pilot	1. Gas line contains air	1. Purge air from gas line
	2. Pilot line, orifice, or passage blocked	2. Check and clean per Maintenance section
	3. Pilot solenoid valve inoperative	3. Replace combination gas valve
Pilot goes out on 100% shut-off when hold-down button is released	1. Heat on pilot flame sensor insufficient	1. Clean pilot, check pilot orifice and alignment
	2. Pilot flame sensor location improper	2. Correct position with respect to pilot
	3. Manifold gas pressure low	3. See rating plate on heater and adjust pressure
	4. Poor contact at valve end of sensing element	4. Ensure clean and proper contact
	5. Pilot flame sensor defective	5. Replace pilot flame sensor
	6. Pilot interrupter in combination gas valve defective	6. Replace combination gas valve
Pilot burning, no gas to main burner(s)	1. Thermostat or manual switch open	1. Raise the thermostat setting or close switch
	2. Manual valve closed on combination gas valve	2. Turn valve to "ON" position
	3. No power to solenoid in combination gas valve	3. Check power supply and furnish proper voltage
	4. Heat on pilot flame sensor insufficient	4. Clean pilot, check pilot orifice and alignment
	5. Pilot flame sensor defective	5. Replace sensor
	6. Combination gas valve defective	6. Replace combination gas valve

17. TROUBLESHOOTING (2 OF 2)

SYMPTOM	POSSIBLE CAUSE	CORRECTIVE ACTION
Heater will not turn off	1. Thermostat defective	1. Replace thermostat
Controls overheating	1. Heater mounted incorrectly	1. See Mounting and Suspending sections
Burning of gas inside burner (flash-back)	1. Heater mounted incorrectly	1. See Mounting and Suspending sections
	2. Gas leaking from: manifold, control assembly, or pilot joints causing gas ignition at orifice	2. Check joints with soap solution, tighten as needed
	3. Ceramic tile(s) cracked or separating	3. Replace burner
	4. Drafts excessive	4. Shield from drafts or relocate heater
Carbon formation on ceramic surface or burner	1. Gas supplied is wrong type	1. Check rating plate for type of gas required
	2. Venturi obstructed (by spider web)	2. Clean with a bottle brush
	3. Pilot depositing carbon	3. Clean pilot and check pilot orifice
	4. Supply/manifold gas pressure too low	4. See rating plate on heater and adjust pressure(s)
	5. Main gas orifice(s) misaligned	5. Consult sales agent or factory
Dark spots on ceramic surface	1. Foreign matter behind the ceramic surface	1. See Maintenance section
	2. Foreign matter inside burner assembly	2. Replace burner assembly
Low ceramic surface temperature	1. Venturi obstructed (by spider web)	1. Clean with a bottle brush
	2. Foreign matter in venturi	2. See Maintenance section
	3. Orifice partially blocked	3. See Maintenance section
	4. Supply gas pressure low	4. Adjust supply regulator to 7" WC (18cm WC) for natural gas, or 11" WC (28cm WC) for propane
	5. Manifold gas pressure low	5. Adjust heater regulator to 6" WC (15cm WC) for natural gas, or 10" WC (25cm WC) for propane
	6. Manifold misaligned from excessive torque applied on pipe at installation	6. Replace manifold
	7. Flue gases not adequately ventilated	7. See Ventilation Requirements section
	8. Gas supply piping too small	8. Increase supply pressure or replace piping
2-Stage transition from low-heat to high-heat does not happen	1. Ambient temperature is still in low-heat zone of thermostat	1. Check thermostat manufacturers' instructions
	2. Thermostat defective	2. Replace thermostat
	3. High-heat valve not opening	3. Replace high-heat valve
2-Stage transition from high-heat to low-heat does not happen	1. Ambient temperature has not reached low-heat zone of thermostat	1. Allow time for ambient temperature to reach low-heat zone of thermostat. Check thermostat manufacturers' instructions
	2. Thermostat defective	2. Replace thermostat
	3. High-heat valve not closing	3. Replace high-heat valve

18. MODEL NUMBERS

DESIGNATION	MBTUH	IGNITION	CONTROL
MHR	100	S	47
MHR = Modine High Intensity Radiant	30 (Natural) 50 (LP) 60 (Natural) 90 (LP) 100 (Natural) 120 (Natural & LP) 150 (Natural) 160 (Natural & LP) 200 (Natural)	S = Direct Spark M = Millivolt	47 = Natural, 120V, Direct Spark, 1-Stage 48 = Natural, 24V, Direct Spark, 1-Stage 97 = Propane, 120V, Direct Spark, 1-Stage 98 = Propane, 24V, Direct Spark, 1-Stage 27 = Natural, Millivolt, 1-Stage 67 = Propane, Millivolt, 1-Stage 38 = Natural, 24V, Direct Spark, 2-Stage 88 = Propane, 24V, Direct Spark, 2-Stage

COMMERCIAL WARRANTY

Seller warrants its products to be free from defects in material and workmanship, EXCLUSIVE, HOWEVER, of failures attributable to the use of materials substituted under emergency conditions for materials normally employed. This warranty covers replacement of any parts furnished from the factory of Seller, but does not cover labor of any kind and materials not furnished by Seller, or any charges for any such labor or materials, whether such labor, materials or charges thereon are due to replacement of parts, adjustments, repairs, or any other work done. This warranty does not apply to any equipment which shall have been repaired or altered outside the factory of Seller in any way so as, in the judgment of Seller, to affect its stability, nor which has been subjected to misuse, negligence, or operating conditions in excess of those for which such equipment was designed. This warranty does not cover the effects of physical or chemical properties of water or steam or other liquids or gases used in the equipment.

BUYER AGREES THAT SELLER'S WARRANTY OF ITS PRODUCTS TO BE FREE FROM DEFECT IN MATERIAL AND WORKMANSHIP, AS LIMITED HEREIN, SHALL BE IN LIEU OF AND EXCLUSIVE OF ALL OTHER WARRANTIES, EITHER EXPRESS OR IMPLIED, WHETHER ARISING FROM LAW, COURSE OF DEALING, USAGE OF TRADE, OR OTHERWISE, **THERE ARE NO OTHER WARRANTIES, INCLUDING WARRANTY OF MERCHANTABILITY OR FITNESS FOR PURPOSE, WHICH EXTEND BEYOND THE PRODUCT DESCRIPTION CONFIRMED BY BUYER AND SELLER AS OF THE DATE OF FINAL AGREEMENT.**

This warranty is void if the input to the product exceeds the rated input as indicated on the product serial plate by more than 5% on gas-fired and oil-fired units, or if the product in the judgment of SELLER has been installed in a corrosive atmosphere, or subjected to corrosive fluids or gases, been subjected to misuse, negligence, accident, excessive thermal shock, excessive humidity, physical damage, impact, abrasion, unauthorized alterations, or operation contrary to SELLER'S printed instructions, or if the serial number has been altered, defaced or removed.

BUYER AGREES THAT IN NO EVENT WILL SELLER BE LIABLE FOR COSTS OF PROCESSING, LOST PROFITS, INJURY TO GOODWILL, OR ANY OTHER CONSEQUENTIAL OR INCIDENTAL DAMAGES OF ANY KIND RESULTING FROM THE ORDER OR USE OF ITS PRODUCT, WHETHER ARISING FROM BREACH OF WARRANTY, NONCONFORMITY TO ORDERED SPECIFICATIONS, DELAY IN DELIVERY, OR ANY LOSS SUSTAINED BY THE BUYER.

BUYER'S REMEDY FOR BREACH OF WARRANTY, EXCLUSIVE OF ALL OTHER REMEDIES PROVIDED BY LAW, IS LIMITED TO REPAIR OR REPLACEMENT AT THE FACTORY OF SELLER, ANY COMPONENT WHICH SHALL, WITHIN THE APPLICABLE WARRANTY PERIOD DEFINED HEREIN AND UPON PRIOR WRITTEN APPROVAL, BE RETURNED TO SELLER WITH TRANSPORTATION CHARGES PREPAID AND WHICH THE EXAMINATION OF SELLER SHALL DISCLOSE TO HAVE BEEN DEFECTIVE; EXCEPT THAT WHEN THE PRODUCT IS TO BE USED BY BUYER AS A COMPONENT PART OF EQUIPMENT MANUFACTURED BY BUYER, BUYER'S REMEDY FOR BREACH, AS LIMITED HEREIN, SHALL BE LIMITED TO ONE YEAR FROM DATE OF SHIPMENT FROM SELLER. FOR GAS-FIRED PRODUCTS INSTALLED IN HIGH HUMIDITY APPLICATIONS AND UTILIZING STAINLESS STEEL HEAT EXCHANGERS, BUYER'S REMEDY FOR BREACH, AS LIMITED HEREIN, SHALL BE LIMITED TO TEN YEARS FROM DATE OF SHIPMENT FROM SELLER.

These warranties are issued only to the original owner-user and cannot be transferred or assigned. No provision is made in these warranties for any labor allowance or field labor participation. Seller will not honor any expenses incurred in its behalf with regard to repairs to any of Seller's products. No credit shall be issued for any defective part returned without proper written authorization (including, but not limited to, model number, serial number, date of failure, etc.) and freight prepaid.

OPTIONAL SUPPLEMENTAL WARRANTY

Provided a supplemental warranty has been purchased, Seller extends the warranty herein for an additional four (4) years on certain compressors. Provided a supplemental warranty has been purchased, Seller extends the warranty herein for an additional four (4) years or nine (9) years on certain heat exchangers.

EXCLUSION OF CONSUMABLES & CONDITIONS BEYOND SELLER'S CONTROL

This warranty shall not be applicable to any of the following items: refrigerant gas, belts, filters, fuses and other items consumed or worn out by normal wear and tear or conditions beyond Seller's control, including (without limitation as to generality) polluted or contaminated or foreign matter contained in the air or water utilized for heat exchanger (condenser) cooling or if the failure of the part is caused by improper air or water supply, or improper or incorrect sizing of power supply.

Component Applicable Models	"APPLICABLE WARRANTY PERIOD"
Heat Exchangers Gas-Fired Units except PSH/BSH	TEN YEARS FROM DATE OF FIRST BENEFICIAL USE BY BUYER OR ANY OTHER USER, WITHIN TEN YEARS FROM DATE OF RESALE BY BUYER OR ANY OTHER USER, WITHIN TEN YEARS FROM DATE OF RESALE BY BUYER IN ANY UNCHANGED CONDITION, OR WITHIN ONE HUNDRED TWENTY-SIX MONTHS FROM DATE OF SHIPMENT FROM SELLER, WHICHEVER OCCURS FIRST
Heat Exchangers Low Intensity Infrared Units Compressors Condensing Units for Cassettes	FIVE YEARS FROM DATE OF FIRST BENEFICIAL USE BY BUYER OR ANY OTHER USER, WITHIN FIVE YEARS FROM DATE OF RESALE BY BUYER OR ANY OTHER USER, WITHIN FIVE YEARS FROM DATE OF RESALE BY BUYER IN ANY UNCHANGED CONDITION, OR WITHIN SIXTY-SIX MONTHS FROM DATE OF SHIPMENT FROM SELLER, WHICHEVER OCCURS FIRST
Burners Low Intensity Infrared Units Other Components excluding Heat Exchangers, Coils, Condensers, Burners, Sheet Metal	TWO YEARS FROM DATE OF FIRST BENEFICIAL USE BY BUYER OR ANY OTHER USER, WITHIN TWO YEARS FROM DATE OF RESALE BY BUYER IN ANY UNCHANGED CONDITION, OR WITHIN THIRTY MONTHS FROM DATE OF SHIPMENT FROM SELLER, WHICHEVER OCCURS FIRST
Heat Exchangers/Coils Indoor and Outdoor Duct Furnaces and System Units, PSH/BSH, Steam/Hot Water Units, Oil-Fired Units, Electric Units, Cassettes, Vertical Unit Ventilators Compressors Vertical Unit Ventilators Burners High Intensity Infrared Units Sheet Metal Parts All Products	ONE YEAR FROM DATE OF FIRST BENEFICIAL USE BY BUYER OR ANY OTHER USER, WITHIN ONE YEAR FROM DATE OF RESALE BY BUYER IN ANY UNCHANGED CONDITION, OR WITHIN EIGHTEEN MONTHS FROM DATE OF SHIPMENT FROM SELLER, WHICHEVER OCCURS FIRST

As Modine Manufacturing Company has a continuous product improvement program, it reserves the right to change design and specifications without notice.



Commercial Products Group
 Modine Manufacturing Company
 1500 DeKoven Avenue
 Racine, WI 53403
 Phone: 1.800.828.4328 (HEAT)
 www.modinehvac.com