

# Electrolux

## Refrigeration

### SMART 1 Split Door Freezer (23 FT<sup>3</sup>)

ITEM # \_\_\_\_\_

MODEL # \_\_\_\_\_

PROJECT NAME # \_\_\_\_\_

SIS # \_\_\_\_\_

AIA # \_\_\_\_\_



#### Refrigeration SMART 1 Split Door Freezer (23 FT<sup>3</sup>)

726678 (RH06FE2HU)	23 ft <sup>3</sup> Full Size Freezer 1 split door 115 V/1p/60Hz
727019 (RH06FE2HRU)	23 ft <sup>3</sup> Full Size Freezer 1 split door 115 V/1p/60Hz remote version

#### Short Form Specification

Item No. \_\_\_\_\_

The Electrolux range of refrigerated cabinets are built with external and internal AISI 304 stainless steel. High-density expanded polyurethane insulating foam, 3" (75 mm) in thickness. Full door with lock and microswitch to switch off the fan when the door is opened. Built-in refrigeration unit; ventilated operating mode; SMART Electronic Control equipped with: history (HACCP) for critical high temperature, alarm service, full diagnostic, remote control via modem; electronic defrost only when required; defrost outlet pipe; external digital temperature display. Humidity level adjustment. Internal lighting. Cavity drain. For ambient temperatures up to 110 °F (43 °C). CFC and HCFC free. R134a gas in refrigeration circuit. Gas in foam: cyclopentane. Energy Star certification for energy savings. Supplied with n. 4 x 2/1GN Rilsan® coated grids and n. 4 sets of 2 stainless steel grid runners.

Covered by Electrolux Platinum Star® Service Program two-year parts and one-year labor warranty, installation start-up and performance check-up after one year from installation.



5-15P

Approval: \_\_\_\_\_

#### Main features

##### EASY TO INSTALL

- Mounted on adjustable stainless steel feet, with castors as an option.
- Choice of doors to suit varying kitchen requirements.
- Freezer models have operating temperatures that can be adjusted from 5 °F to -11 °F (-15 to -24 °C) to suit both meat and dairy storage requirements.
- Performance guaranteed at ambient temperatures of 110 °F (43 °C).

##### EASY TO CLEAN

- Forced air circulation for rapid cool down and even temperature uniformity.
- Constructed from the highest quality AISI 304 stainless steel.
- Interior base with corners, pressed from a single sheet.
- Sides and back of the 1-door models are formed from a single sheet of stainless steel to avoid dirt traps.
- Evaporator unit is placed outside the cell to provide the maximum storage capacity.
- Refrigerators are fitted with outlet pipe.

##### EASY TO USE

- Accommodates GN 2/1 containers or shelves on anti-tilt runners.
- External digital temperature display.
- Interior light and lockable door.
- SMART electronic control gives the following benefits:
  - HACCP: when temperature exceeds critical limits, an acoustic and visual alarm are activated. All events are recorded displaying date and time of all events.
  - SMART defrost: the defrost cycle is activated only when necessary thanks to the four-probe control and a patented algorithm for ice detection.
  - Intelligence when failure: when a probe breaks it remembers its performance of last 24 hours and continue to work. In this way food is safe and service can be called.
  - Diagnostic: four probes constantly control working condition of the appliances.
  - Food categories: depending by food stored it can be selected appropriate temperature and humidity just pushing a button.

##### EASY TO MAINTAIN

- Heavy-duty construction that avoids use of any plastic parts.
- The cooling unit (compressor, condenser and evaporator) can be removed with a single operation from either the top or back.
- Evaporator cover is easily removable for service.
- Fault indication from the smart control.

##### EASY ON THE ENVIRONMENT

- SMART electronics defrost only when required to save energy.
- Cabinet fitted with up to 3" (75 mm) thickness of cyclopentane insulation for best insulating performance. CFC and HCFC-free insulation.
- Refrigerant type: R134a or R404a.

#### Accessories

- Pair of stainless steel runners for 23 and 50 ft<sup>3</sup> SMART refrigerators 4
- Rilsan® coated full-size sheet grid 4

#### Optional Accessories

- Basic HACCP Printer (PNC 880048)
- 4 wheels (2 with brake) (PNC 880121)
- Pair of stainless steel runners for 23 and 50 ft<sup>3</sup> SMART refrigerators (PNC 880175)
- Rilsan® coated full-size sheet grid (PNC 880176)
- Pedal opening for 23 ft<sup>3</sup> SMART refrigerators (PNC 881458)



Electrolux

SMART 1 Split Door Freezer (23 FT<sup>3</sup>)  
Refrigeration

Electrolux Professional, Inc.

www.electroluxusa.com/professional

3225 SW 42nd Street, Fort Lauderdale, Florida, 33312 • Telephone Number: 866-449-4200 • Fax Number: 954-327-6789

**Front View**

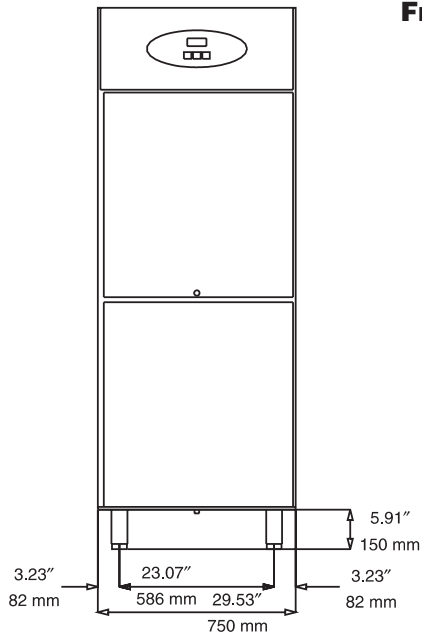

**Top View**

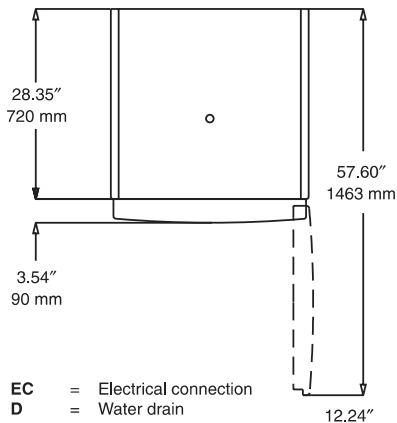

**Side View**

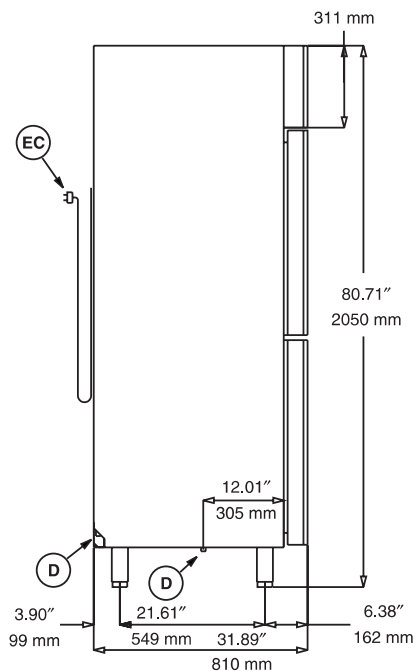

### Electric

**Supply voltage:**

726678 (RH06FE2HU)	115 V/1p/60Hz - 12A
727019 (RH06FE2HRU)	115 V/1p/60Hz - 12A

### Key Information

**LEGEND**

C - Water Drain	1/2" (12.7 mm)
I - Electrical Connection	115 V/1p/60Hz

**TECHNICAL DATA**

**Operating temperature min.:** 5 °F (-15 °C)

**Operating temperature max.:** -11 °F (-24 °C)

**Built-in Compressor and Refrigeration Unit**

**External Dimensions:**

<b>Width:</b>	29-1/2" (750 mm)
<b>Depth:</b>	31-7/8" (810 mm)
<b>Depth (with doors open)</b>	57-1/2" (1463 mm)
<b>Height:</b>	80-11/16" (2050 mm)
<b>Min/Max internal humidity %:</b>	75/ 90
<b>Number and type of doors:</b>	2 Half
<b>Door hinges:</b>	Right
<b>Number and type of grids (included):</b>	4, GN 2/1
<b>Compressor power:</b>	1/2 HP
<b>Refrigerant type:</b>	R404a
<b>Refrigerant quantity:</b>	250g
<b>Refrigerant Power:</b>	1471W
<b>Power:</b>	780 watts
<b>Net weight:</b>	304 lbs (138 kg)