

OPERATOR SERVICE MANUAL SAM G



POSITECH CORPORATION
191 N RUSH LAKE ROAD
LAURENS, IA 50554
Phone Number: 800-831-6026
24 Hour Service Phone Number: 541-954-2948
Email: service@positech.com

SERIAL NO: _____
RUN NO: _____

REV A
04APR14

NOTES:

A series of horizontal dotted lines intended for handwritten notes, spanning the width of the page below the 'NOTES:' header.

Table of Contents

SECTION 1 - SAFETY INFORMATION – READ BEFORE USING:	2
1.1 MEANING OF SYMBOLS:	2
1.2 DO'S AND DO NOT'S:	1
1.3 SAFETY PRECAUTIONS:	2
SECTION 2 - NAMING CONVENTION AND SERIAL TAG:	3
2.1 NAMING CONVENTION:	3
2.2 SERIAL TAG LOCATION AND NOMENCLATURE:	4
SECTION 3 - SPECIFICATIONS:	5
3.1 MECHANICAL SPECIFICATIONS:	5
3.2 PNEUMATIC SPECIFICATIONS:	5
3.3 HYDRAULIC SPECIFICATIONS:	5
3.4 ELECTRICAL SPECIFICATIONS:	5
3.5 AERIAL NOISE:	5
3.6 ENVIRONMENTAL CONDITIONS:	5
3.7 OVERTURNING MOMENT, WEIGHT, & MOUNTING PATTERN:	6
3.7.1 PEDESTAL MOUNTING PATTERN:	7
3.7.2 OVERHEAD SPACER MOUNTING PATTERN:	7
3.8 CONCRETE MOUNTING GUIDELINES:	8
3.8.1 SOIL CONDITION:	8
3.8.2 FULLY REINFORCED CONCRETE FLOOR CONDITION:	8
3.8.3 POURED FOUNDATION CONDITION:	8
3.8.4 PLATING ON CONCRETE:	8
SECTION 4 - INSTALLATION INSTRUCTIONS:	9
4.1 PALLET INFORMATION:	9
4.2 PEDESTAL INSTALLATION:	10
4.3 SPACER INSTALLATION:	11
4.4 LIFTING WITH A FORK TRUCK WHEN STILL ON PALLET:	12
4.5 LIFTING WITH AN OVERHEAD CRANE:	13
4.6 ATTACHING MANIPULATOR TO PEDESTAL:	14
4.7 ATTACHING MANIPULATOR TO SPACER:	14
4.8 DISASSEMBLING THE PALLET:	15
4.9 INSTALLING TOOLING (U-FRAME) FROM FACTORY:	16
SECTION 5 - MAINTENANCE, ADJUSTMENTS, & INSPECTIONS:	17
5.1 LUBRICATION SCHEDULE:	19
5.2 ADJUSTING A DUAL LOST LOAD LOCK VALVE:	20
5.2.1 UNLOCKING A LOCKED LOST LOAD CYLINDER:	20
5.2.2 CHECKING IF LOST LOAD WORKS PROPERLY:	20
5.2.3 ADJUSTING A LOST LOAD VALVE THAT IS TOO SENSITIVE:	21
5.3 CHANGING SEALS IN THE DUAL LOST LOAD CYLINDER:	22
5.4 REBUILDING A PISTON TYPE LIFT CYLINDER:	23
5.5 ADJUSTING THE FORCE LINK ROLLER:	24
5.6 ADJUSTING THE LIFT HOUSING ROLLER ASSEMBLIES:	25
5.7 TIGHTENING THE ACHOR BOLTS:	25
5.8 LEVELING THE PEDESTAL OR SPACER AFTER INSTALLATION:	26
5.9 AIR LINE SIZING FOR SUPPLY AIR:	27
SECTION 6 - TROUBLESHOOTING:	28
SECTION 7 - DRAWINGS:	29
SECTION 8 - RECOMMENDED SPARE PARTS:	30

SECTION 1 - SAFETY INFORMATION – READ BEFORE USING:



Important: Read and understand these warnings before operating equipment!

1.1 MEANING OF SYMBOLS:



Danger: Indicates a hazardous situation which if not avoided, will result in death or serious injury. Possible hazards are shown in the adjoining symbols or explained in the text.



Electrical hazard: Contact with live parts can result in immediate death. Protective covers marked with this sign may only be opened by qualified personnel only. Disconnect the feed voltage before opening.



Suspended load overhead: Do not stop or transit near suspended load. Use extreme caution when moving suspended loads; do not leave suspended loads unattended. Do not leave load suspended above people.



Risk of crushing hands and/or feet: Do not approach mechanical parts that are moving or may start moving.



Do not handle the load while standing in front of the terminal arm.



Parts of the manipulator may come into collision with the operator.



Clamping Device: Do not depress the gripping control button unless the correct load to be handled is between the jaws. Keep body parts clear when actuating clamping devices.



Pinch point: Indicates possible pinch point. Keep extremities clear of moving parts. Do not wear loose clothing or jewelry near equipment. Avoid contact with areas marked with this symbol or PINCH POINT text.



Hook point: Be sure hook is secure before lifting. Do not lift people. Be aware of tool sway that may occur when using a hook.



Hot Surface: Surface temperature can exceed greater than 70 deg. C during normal operation. **DO NOT Touch!!**



Pressurized Source Caution. Contents under Pressure. Do not disconnect without turning power off, locking out, and supporting lowered lift arms



Emergency Stop: Stop device activation removes power from all machine functions.



Warning: Indicates a potentially Hazardous situation, which if not avoided could result in **death or serious injury.**



Caution: Indicates a potentially hazardous situation, which if not avoided **may result** in injury















Hearing Protection: Recommended near sources ≥ 80 dbA.















1.2 DO'S AND DO NOT'S:

Perform the following Do's and Do Not's for safe operation of the manipulator. Following these guidelines will increase operator awareness of his/her own safety and the safety of others. Frequent examinations and periodic inspections of the equipment and conscientious observance of safety rules will help prevent injuries, lost production time, and money.

To avoid injury: THE DO'S

-  DO read all warnings and safety information before operating unit.
-  DO become familiar with the operating controls, procedures and warnings.
-  DO make sure that if the manipulator is mounted on a portable base, the support surface is flat and that the leveling jacks touch the floor.
-  DO maintain firm footing while operating the manipulator.
-  DO operate the manipulator arms by pushing and pulling directly in front of the body.
-  DO make sure that the load is free to move and will clear all obstructions.
-  DO make sure that all persons stay clear of the suspended load.
-  DO warn personnel of an approaching load.
-  DO promptly report any malfunction, unusual, performance, or damage to the manipulator.
-  DO inspect the manipulator regularly, replace any damaged or worn parts, and keep appropriate records of maintenance.
-  DO replace damaged or missing labels.
-  DO use Positech parts when repairing the manipulator.

To avoid injury: THE DO NOT'S

-  DO NOT operate manipulator unless qualified to do so.
-  DO NOT modify or alter the manipulator, tooling, or valve settings.
-  DO NOT exceed the rated capacity for the manipulator or tooling.
-  DO NOT use a damaged unit or a unit that is not working correctly.
-  DO NOT allow your attention to be diverted while operating the manipulator.
-  DO NOT operate the manipulator by pushing or pulling that requires twisting the back.
-  DO NOT use the manipulator to lift, support, or transfer people.
-  DO NOT lift loads over people.
-  DO NOT lift loads higher than necessary.
-  DO NOT allow unauthorized personnel within the working area of the manipulator.
-  DO NOT leave a suspended load unattended unless safety precautions have been taken.
-  DO NOT remove or obscure any warning labels on the manipulator.
-  DO NOT adjust the manipulator unless qualified to perform such maintenance or repair.
-  DO NOT set or rest the manipulator on vacuum cups or grip jaws.
-  DO NOT operate equipment in an explosive or humid environment without optional protective features offered and supplied with equipment.

1.3 SAFETY PRECAUTIONS:



Follow basic safety precautions to reduce the risk of damage and personal injury when using powered manipulators.

READ INSTRUCTIONS BEFORE OPERATING MANIPULATOR



REVIEW AND PRACTICE SAFE OPERATION OF THE MANIPULATOR. Become familiar with and practice the Do's and Do Not's for safe operation of the manipulator.



KEEP WORK AREA CLEAN. Cluttered work areas invite injuries.



CONSIDER WORK ENVIRONMENT. Keep work area well lit. Avoid exposing the manipulator to rain or wet locations. The standard manipulator is NOT designed for explosive atmospheres. Special non-standard designs may be required for use in extreme environments. Consult Positech with performance questions related to unique environments.



KEEP CHILDREN AWAY. All visitors and personnel not familiar with the work range of the manipulator should be kept away from the manipulator.



NEVER LIFT, SUPPORT, OR TRANSFER PEOPLE WITH MANIPULATOR OR TOOLING. The manipulator is not designed as a man lift device and using the manipulator or tooling as such is **ABSOLUTELY PROHIBITED.**



DO NOT FORCE THE MANIPULATOR OR TOOLING. The manipulator will perform better and more safely at the realistic rate for which it is intended.



DO NOT OVERREACH OR TWIST. Keep proper footing and balance at all times. Use the vertical rotation axes provided by the bearings of the manipulator to properly position your body to move the load.



USE THE CORRECT TOOL. Use the tooling for what it was designed to handle. Do not use a small tool or attachment to do the job of a heavy-duty tool.



CHECK DAMAGED PARTS OR LOOSE CONNECTIONS. If part of the manipulator becomes damaged, replace with Positech parts. Inspect tooling and manipulator for alignment of moving parts, binding of moving parts, breakage of parts, mounting, and any other conditions that would affect operation of the manipulator. Use the troubleshooting guide and routine maintenance checklist for inspecting the manipulator at regularly scheduled time periods. Contact Positech for service assistance and direction.



USE CAUTION WHEN INSTALLING OR PERFORMING ROUTINE MAINTENANCE. See the specific instructions contained in this manual for lifting and placing the manipulator. Support the lift arm structure when servicing the main lift cylinder. Have a second person assist with lift speed and other adjustments.



PROPERLY STORE AND HANDLE MATERIALS USED FOR MAINTAINING THE MANIPULATOR. Material Safety Data Sheets (MSDS) are included for proper storage, handling, and use of lubricants and other materials included with the manipulator

SECTION 2 - NAMING CONVENTION AND SERIAL TAG:

2.1 NAMING CONVENTION:

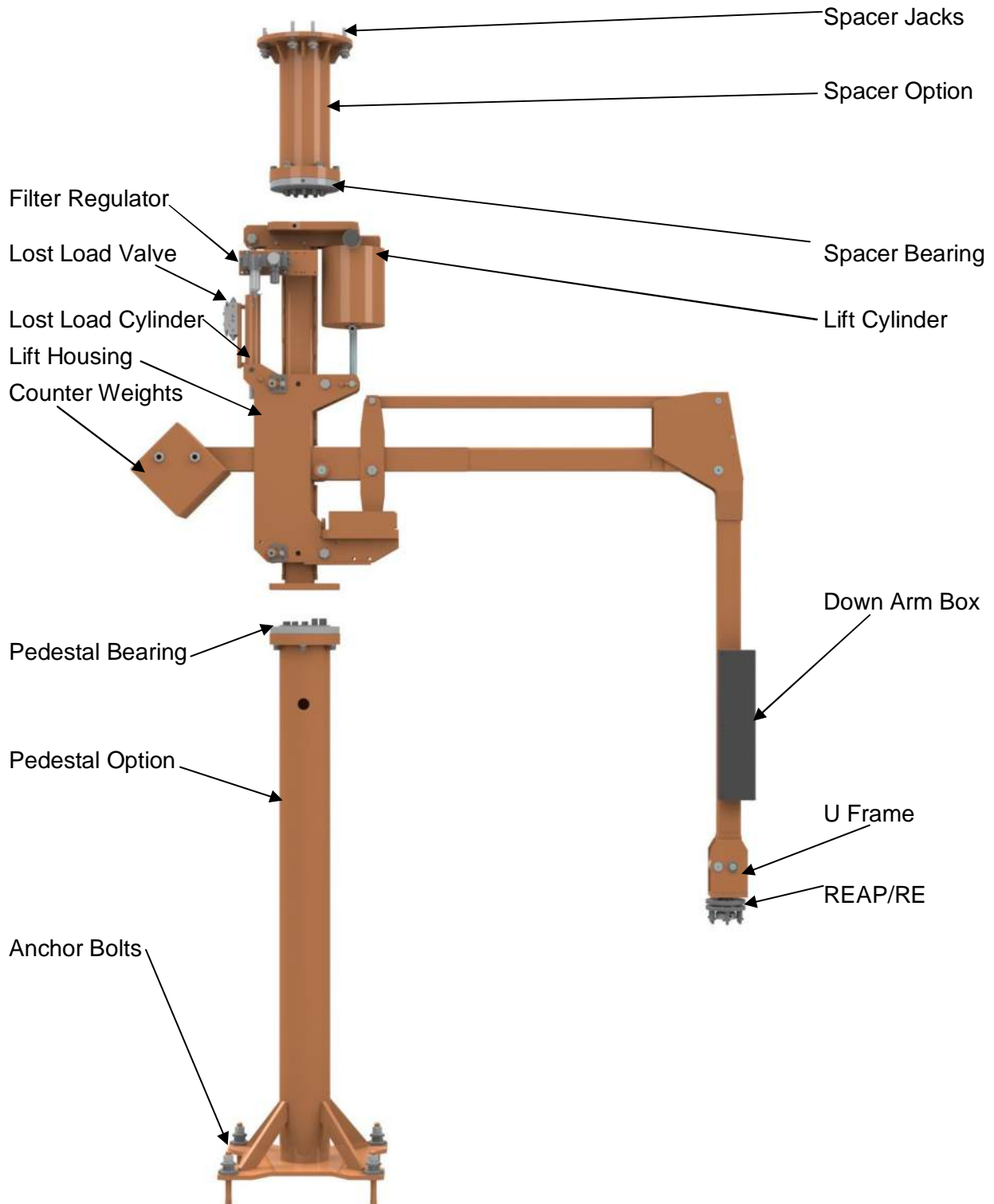

2.2 SERIAL TAG LOCATION AND NOMENCLATURE:

Model Number Serial Number – PROVIDE FOR SERVICE SUPPORT Julian Date – 2 digit year & 3 digit day

Capacity of Base Machine Only

Electical Amps

Air SCFM

Air PSI Electrical Voltage/Hertz/Phase

MODEL _____

SERIAL NO. _____ JD _____

MACHINE CAPACITY (LBS/KG) _____

SUPPLY VOLTAGE (V/HZ/PH) _____ FULL LOAD AMPS _____

PRESSURE (PSI/BAR) _____ FLOW (SCFM - LM) _____

Positech
CORPORATION

POSITECH
LAURENS, IA 50554
800-831-6026
WWW.POSITECH.COM

Serial Tag Location

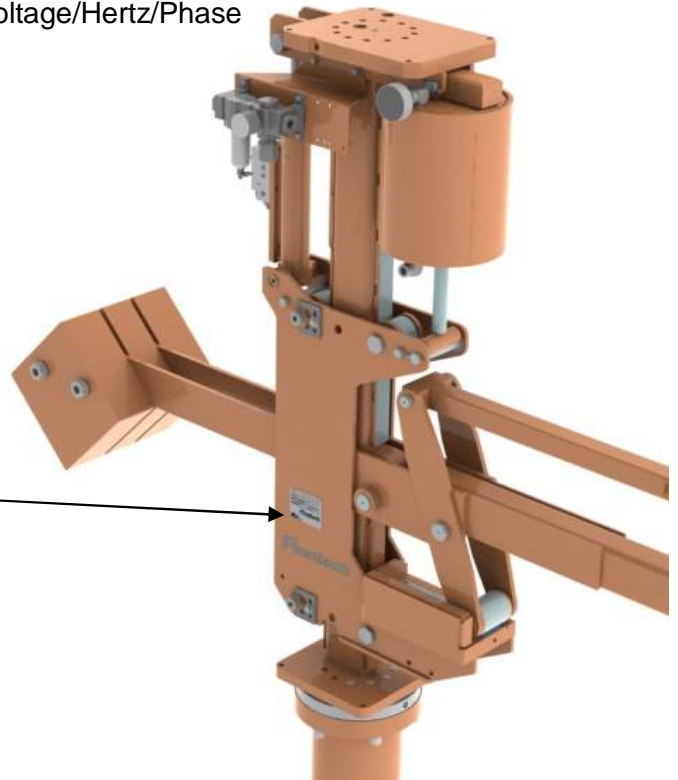

SECTION 3 - SPECIFICATIONS:

3.1 MECHANICAL SPECIFICATIONS:

Main post overturning moment capacity:	40,000 in-lbs [4,520 Nm]
Approximate system weight (based on reach):	1200 lbs [544 Kg]
End joint capacity:	5,000 in-lbs [565 Nm]
Lift capacity (based on reach):	150 – 390 lbs [68 to 177 Kg]
Pedestal anchor hole size in concrete:	.625 inch [15 mm]
Pedestal anchor bolt seating torque:	90 to 100 ft-lbs [122 to 136 Nm]
Pedestal anchor bolt torque:	90 ft-lbs [122 Nm]
Spacer mounting bolts (grade 5):	83 ft-lbs [112 Nm]
Main Post Bearing Bolt Torque (Spacer or Pedestal):	300 ft-lbs [408 Nm]
Hoist and Lifting strap capability to lift SAM:	2000 lbs [908 Kg]
Lift cylinder lock nut torque:	250 ft-lbs [340 Nm]
Lift cylinder tie rod torque:	35 ft-lbs [47 Nm]

3.2 PNEUMATIC SPECIFICATIONS:

Air supply	Oil free Filtered to 40 µm
Air must be dry enough to avoid ice formation at temperatures below 35°F (2°C).	
Air pressure required:	80 psi [5.5 bar]
Airflow required (based on reach):	20 – 43 SCFM [566 – 1216 SLM]

3.3 HYDRAULIC SPECIFICATIONS:

Hydraulic fluid used:	Allied AW Hydraulic Oil ISO 46
-----------------------	--------------------------------

3.4 ELECTRICAL SPECIFICATIONS:

Supply Power:

3.5 AERIAL NOISE:

Level of continuous acoustic pressure: <80 dB (A scale)
Aerial noise measurements are taken at the operator's work position and based on a 50th percentile operator's height.

3.6 ENVIRONMENTAL CONDITIONS:

The manipulator is designed to operate inside a protected site from outside environmental conditions. The operating environment needs be free of aggressive contaminants, acids, corrosive gases, salts, etc.

Operating Temperature:	50°F – 120°F [10°C – 49°C]
Relative Humidity:	<95%

3.7 OVERTURNING MOMENT, WEIGHT, & MOUNTING PATTERN:

Main post overturning
moment capacity:
40,000 in-lbs [4,520 Nm]

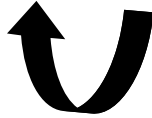

Maximum allowed
deflection from
mounting structure in
any direction is .25°

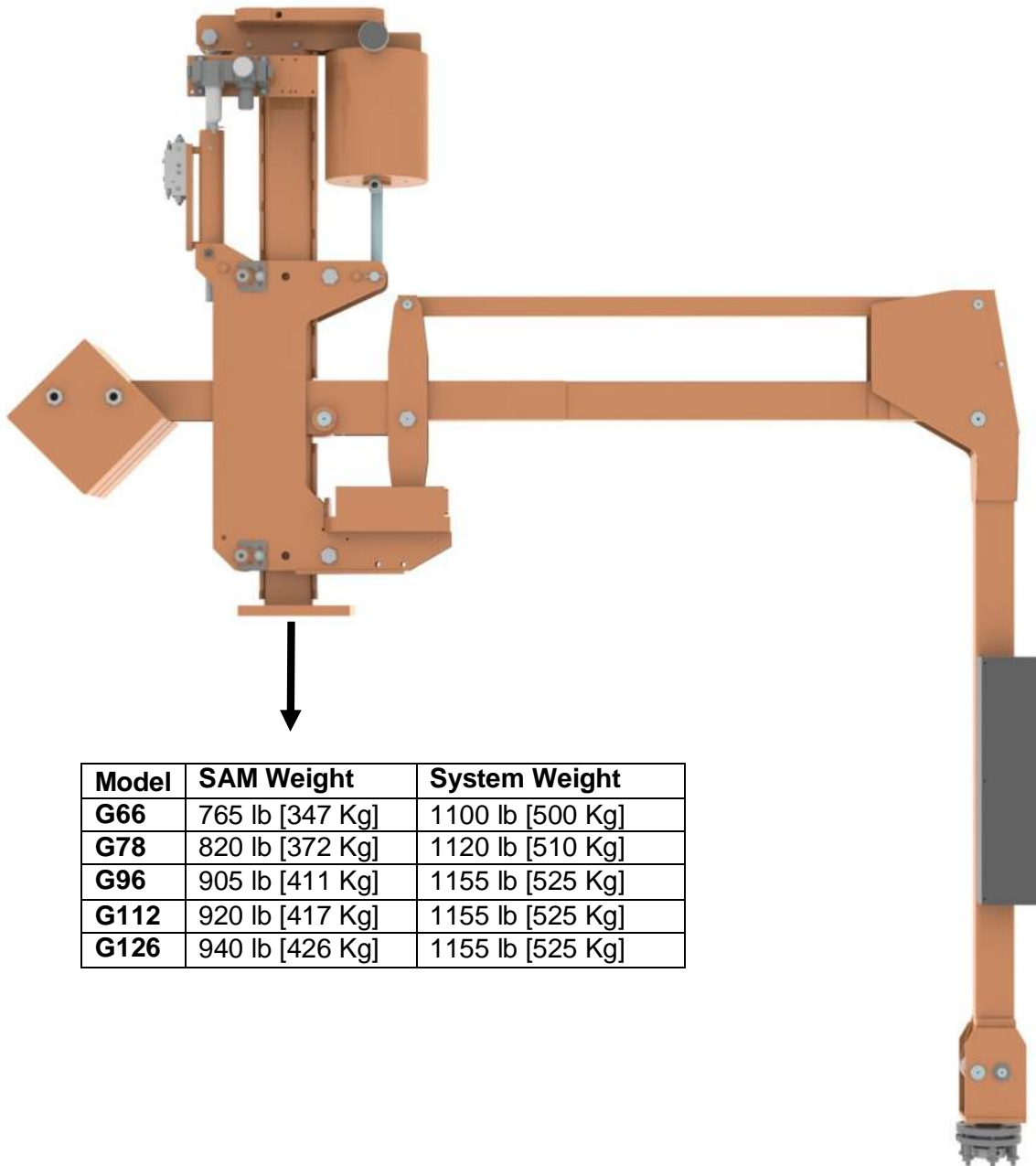

Model	SAM Weight	System Weight
G66	765 lb [347 Kg]	1100 lb [500 Kg]
G78	820 lb [372 Kg]	1120 lb [510 Kg]
G96	905 lb [411 Kg]	1155 lb [525 Kg]
G112	920 lb [417 Kg]	1155 lb [525 Kg]
G126	940 lb [426 Kg]	1155 lb [525 Kg]

3.7.1 PEDESTAL MOUNTING PATTERN:

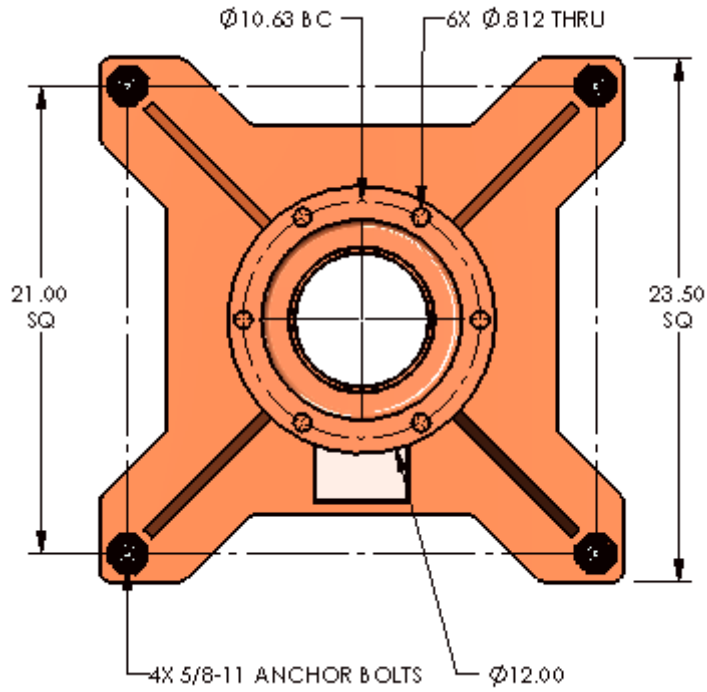

3.7.2 OVERHEAD SPACER MOUNTING PATTERN

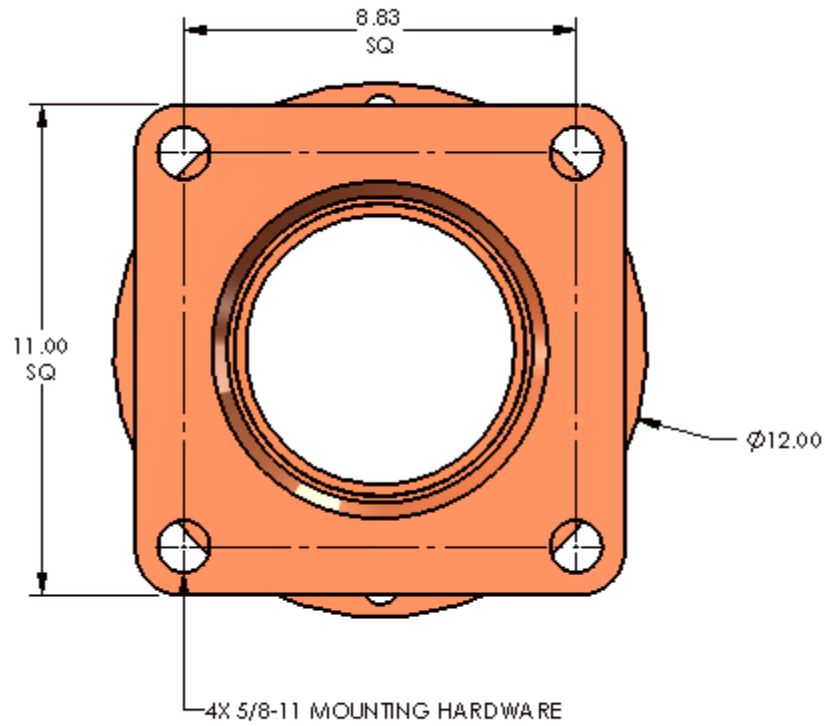

3.8 CONCRETE MOUNTING GUIDELINES:



It is solely the customer's responsibility to provide the proper foundation for the manipulator and if conditions are questionable or concrete does not look adequate consult a qualified professional to inspect and make recommendations.

3.8.1 SOIL CONDITION:

The minimum soil compaction required is 2500 lbs/sq ft [0.12 MPa].

3.8.2 FULLY REINFORCED CONCRETE FLOOR CONDITION:

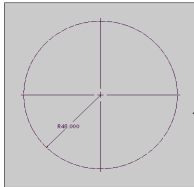

- 6in [152mm] thick
- 3500 psi [24.1 MPa] compressive strength
- No cracks within 48in [1.2m] radius of pedestal

The concrete must be fully reinforced with a minimum of 3,500 psi [24 MPa] compressive strength and 6 inches [152 mm] thick with no cracks within a 48 inch [1.21 m] radius of the pedestal. For customers that can't meet this requirement see below for alternate solutions for attaching your manipulator.

3.8.3 POURED FOUNDATION CONDITION:

Poured foundation requirements are 48 inch [1.21 m] wide x 48 inch [1.21 m] long x 12 inch [0.30 m] deep. The top of slab must be level and the slab needs to be fully reinforced.

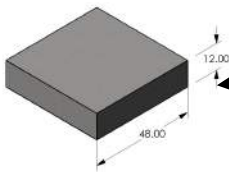

Foundation dimensions:
48" X 48" X 12"

3.8.4 PLATING ON CONCRETE:



If a 4 inch [101 mm] reinforced concrete floor has cracks within 48 inches [1.21 m] of the pedestal consult the factory for a portable base option to mount the manipulator or a foundation must be poured.



When attaching plates to cracked concrete that is 6 inches [152 mm] thick or more the floor anchors need to be 6 inches [152 mm] from any cracks.

A concrete mounting plate can be made that is 36 inches [0.91 m] square and uses four 0.625 inch [15 mm] anchors per side located 1.50 inches [38.10 mm] from the edge. Contact Positech for drawings or ordering information.

36" x 36" x 1.5" – Concrete Mounting Plate – Positech drawing 200821822

SECTION 4 - INSTALLATION INSTRUCTIONS:

4.1 PALLET INFORMATION:



Note: The SAM pallet is designed to allow installation of the SAM without removing from the pallet.

MANIPULATOR AS SHIPPED FROM POSITECH:

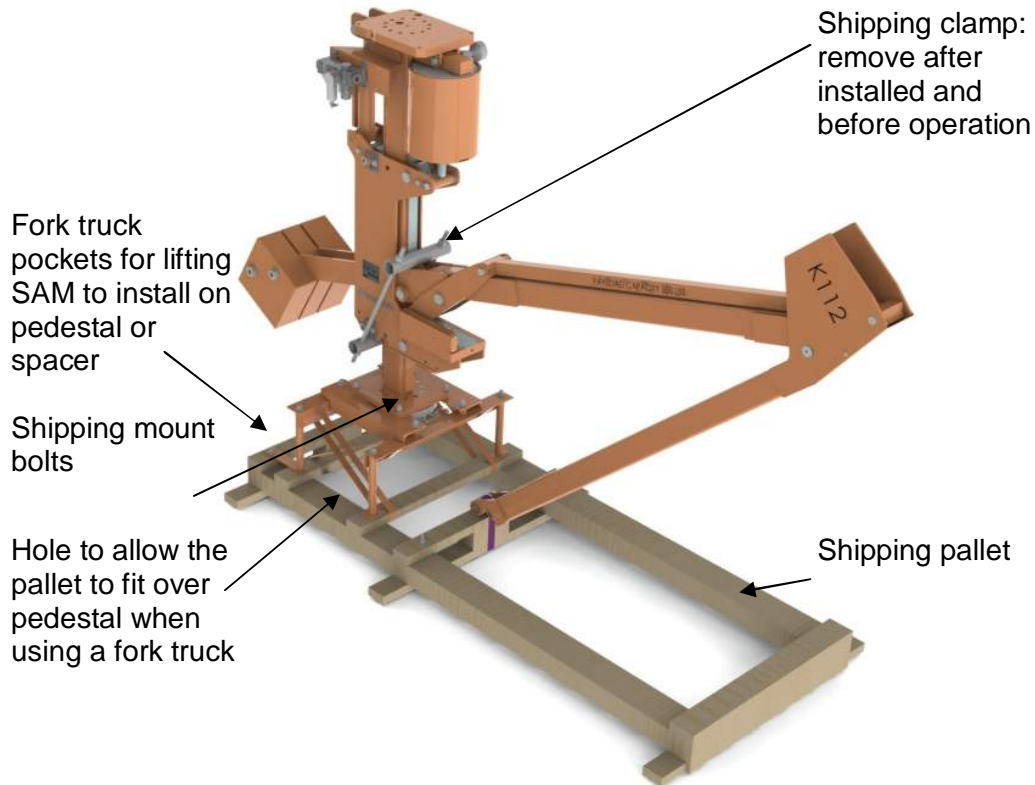

Inspect manipulator and pallet for any signs of damage due to shipping prior to installation. Document damage and make any claims to the carrier.

4.2 PEDESTAL INSTALLATION:



LEVEL PEDESTAL BEFORE INSTALLING MANIPULATOR (See [SECTION 5.8](#) for leveling the manipulator if it is already installed on pedestal.)

Refer to [SECTION 3.8](#) for concrete guidelines before mounting pedestal.

1. Set pedestal over area and drill 0.62 inch [15.87 mm] holes using pedestal for template. Be sure to drill through concrete or at least 2.00 inches [50.80 mm] below anchor. Locate pedestal so air line can be routed through air supply hole.

2. Move pedestal and clean holes with compressed air and nylon brush.



3. Add 1 flat washer between concrete and pedestal for each jack.

4. Assemble anchor with washer, lock washer, and nut below anchor bolt chamfer and drive in with hammer.



5. Torque anchor from 90 to 100 ft-lbs [122 to 136 Nm] to seat anchor. Then loosen.

6. Level pedestal by adjusting the leveling jacks. Use a machinist's level to check in two directions perpendicular to each other.

8. Torque the anchors to 90 ft-lbs [122 Nm]

7. Tighten the jam nuts on jacks against pedestal flange.



FINAL NOTES:

- No grouting is required to mount this pedestal.
- ⚠ Re-torque this pedestal one week after install to 90 ft-lbs [122 Nm].
- ⚠ Re-torque pedestal according to suggested maintenance schedule to 90 ft-lbs [122 Nm].

4.3 SPACER INSTALLATION:



LEVEL SPACER BEFORE INSTALLING MANIPULATOR ON SPACER: (See [SECTION 5.8](#) for leveling the manipulator if it is already installed on spacer.)

1. Install jack and jam nut.

2. Install flat washer, 5/8 grade 5 bolts and lock nuts if necessary.

3. Loosen the jam nut for leveling

4. Loosen the 5/8 bolts enough to level spacer.

5. Level spacer by adjusting the leveling jacks. Use a machinist's level to check in two directions perpendicular to each other.

6. Tighten the 5/8 bolts to 83 ft-lbs [112 Nm]

7. Tighten the jam nuts against spacer.

8. Re-check level of spacer to make sure it is still level

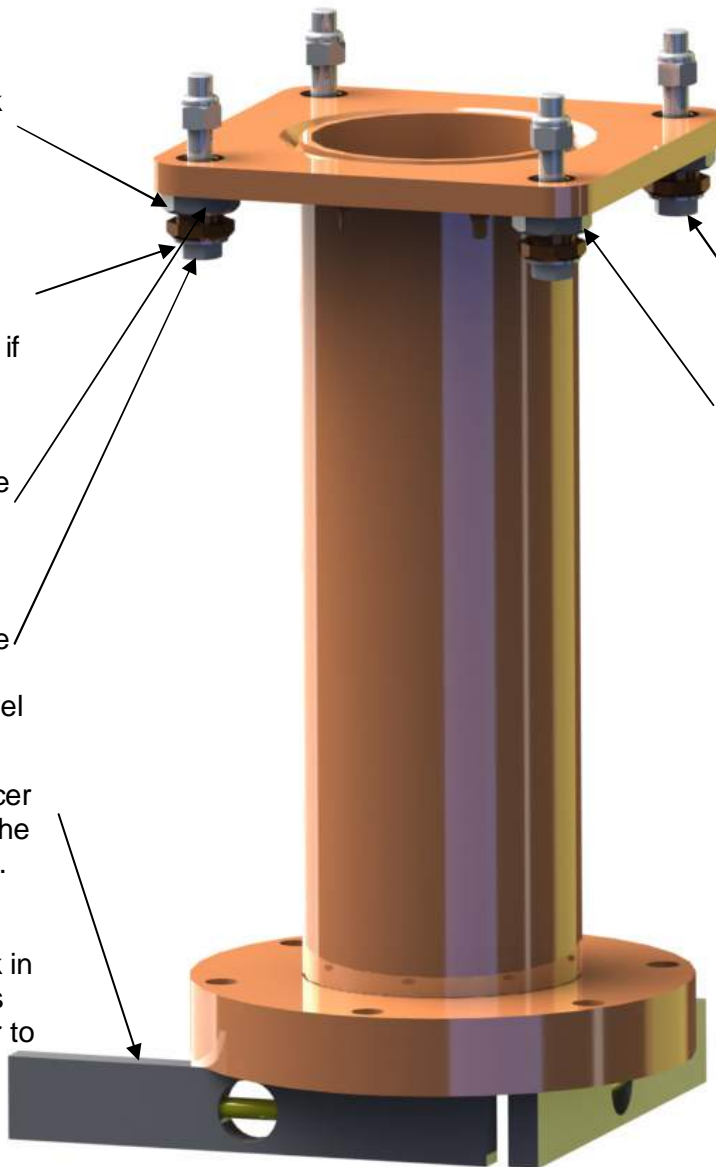

4.4 LIFTING WITH A FORK TRUCK WHEN STILL ON PALLET:

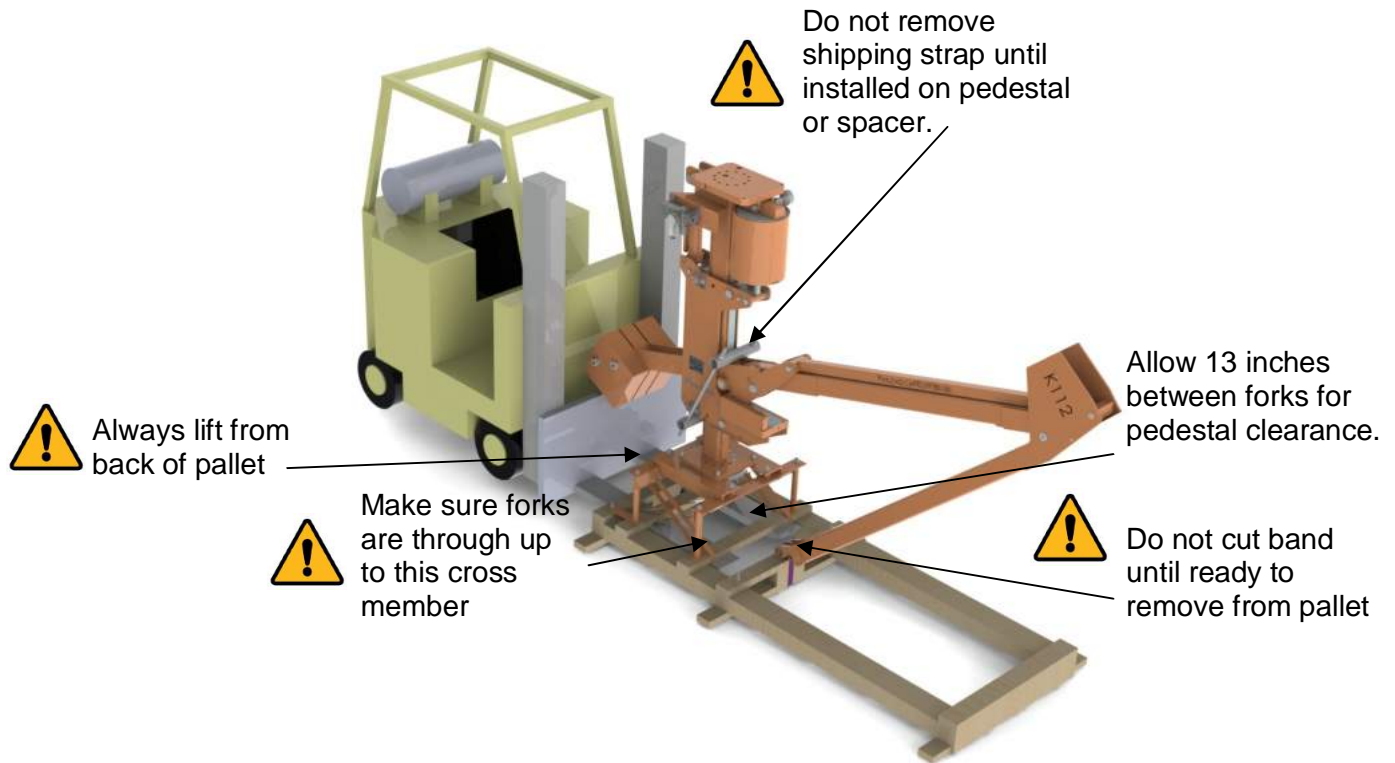

1. Raise pallet above pedestal. See [SECTION 4.2](#) for pedestal leveling before raising the pallet.
2. Lower pallet over pedestal and install according to [SECTION 4.6](#)

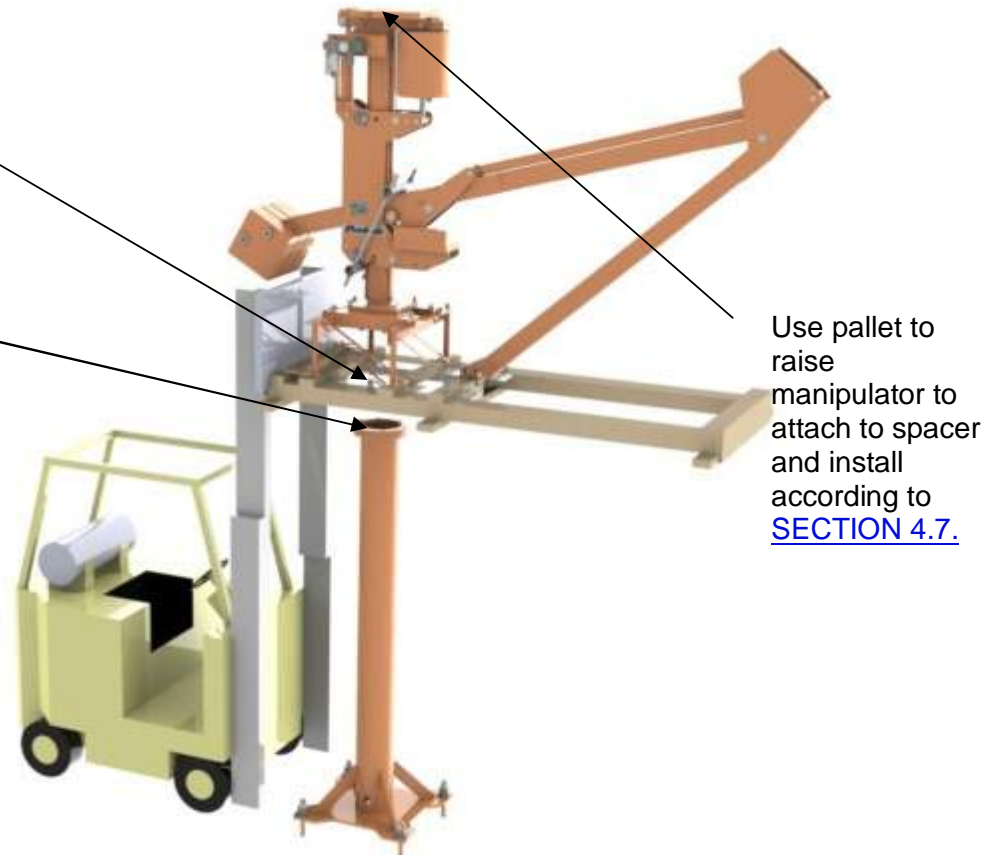

4.5 LIFTING WITH AN OVERHEAD CRANE:



Hoist and strap have to be capable of at least 2000 lbs [908 Kg].

Place strap between cylinder and main post to lift with hoist.



Do not remove the shipping restraint before lifting.

Connect air line to pedestal.



Pallet can be removed before lifting. If not removed, the pedestal will come through the hole under the bearing.

See [SECTION 4.6](#) for bolts torques and process.

Remove tool before lifting with a strap.



Two bolts with the heads cut off can make assembly easier when turned into bearing.



Level and torque the pedestal according to [SECTION 4.2](#) before installing.

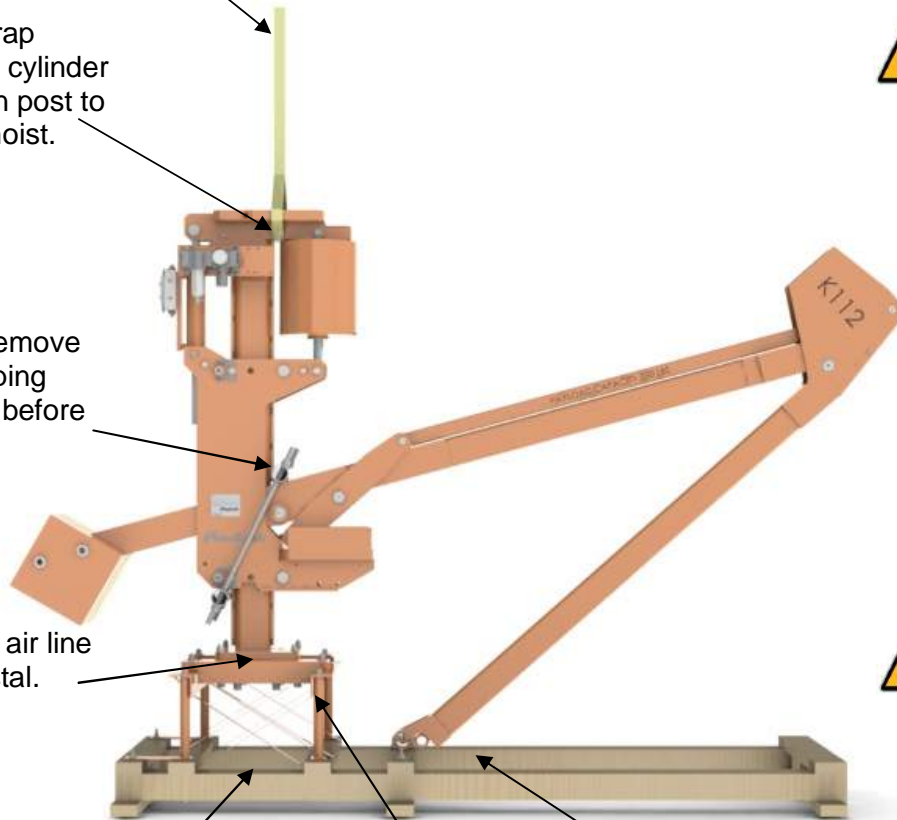

4.6 ATTACHING MANIPULATOR TO PEDESTAL:

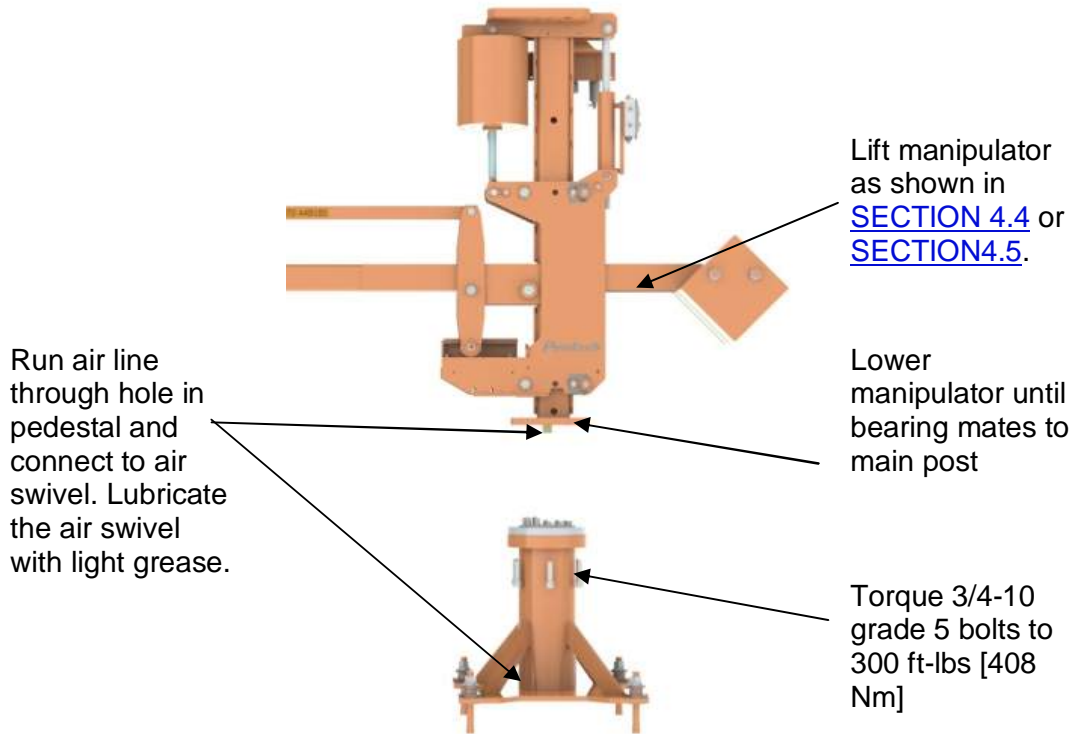

4.7 ATTACHING MANIPULATOR TO SPACER:

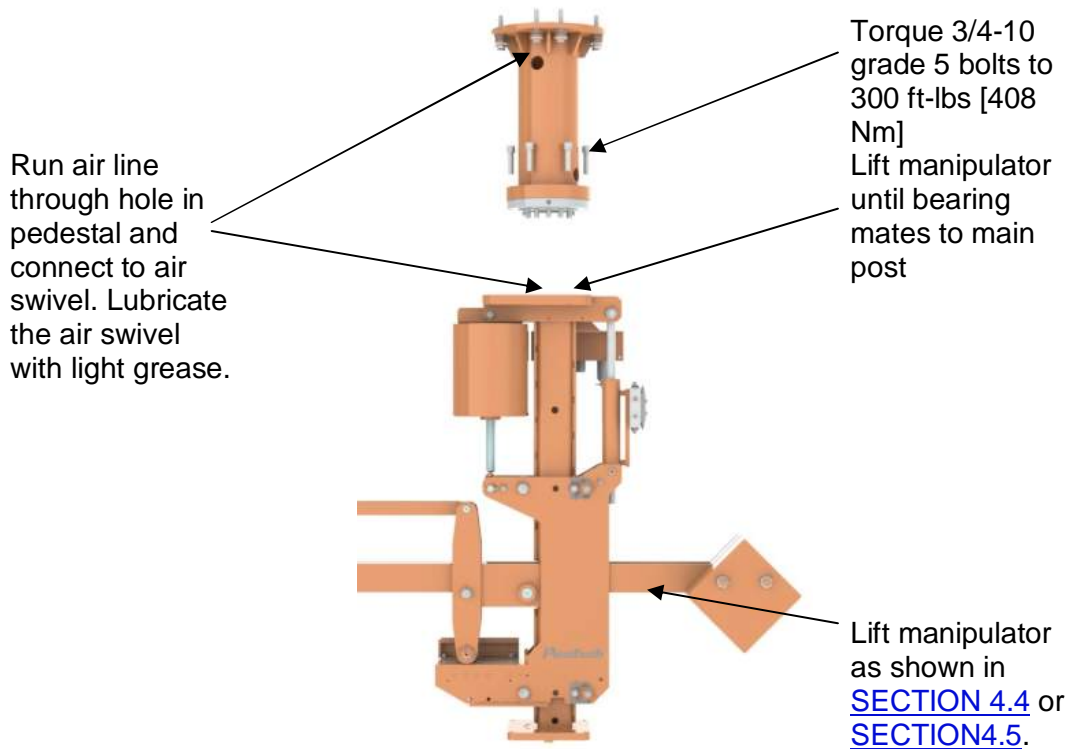

4.8 DISASSEMBLING THE PALLET

After fastening manipulator to pedestal or spacer according to [SECTION 4.6](#) or [SECTION 4.7](#), remove pallet using the following steps.

1. Remove strap holding front of manipulator to pallet.

2. Remove nuts, lock washers, and flat washers from bolts going through boss on pallet framework.

5. Remove shipping restraint.

6. Connect tooling. See [SECTION 4.9](#).



Removing nuts will cause pallet to fall if not supported!

3. Remove nuts holding angle iron to manipulator base.

4. Remove side of pallet to remove pallet from around pedestal.

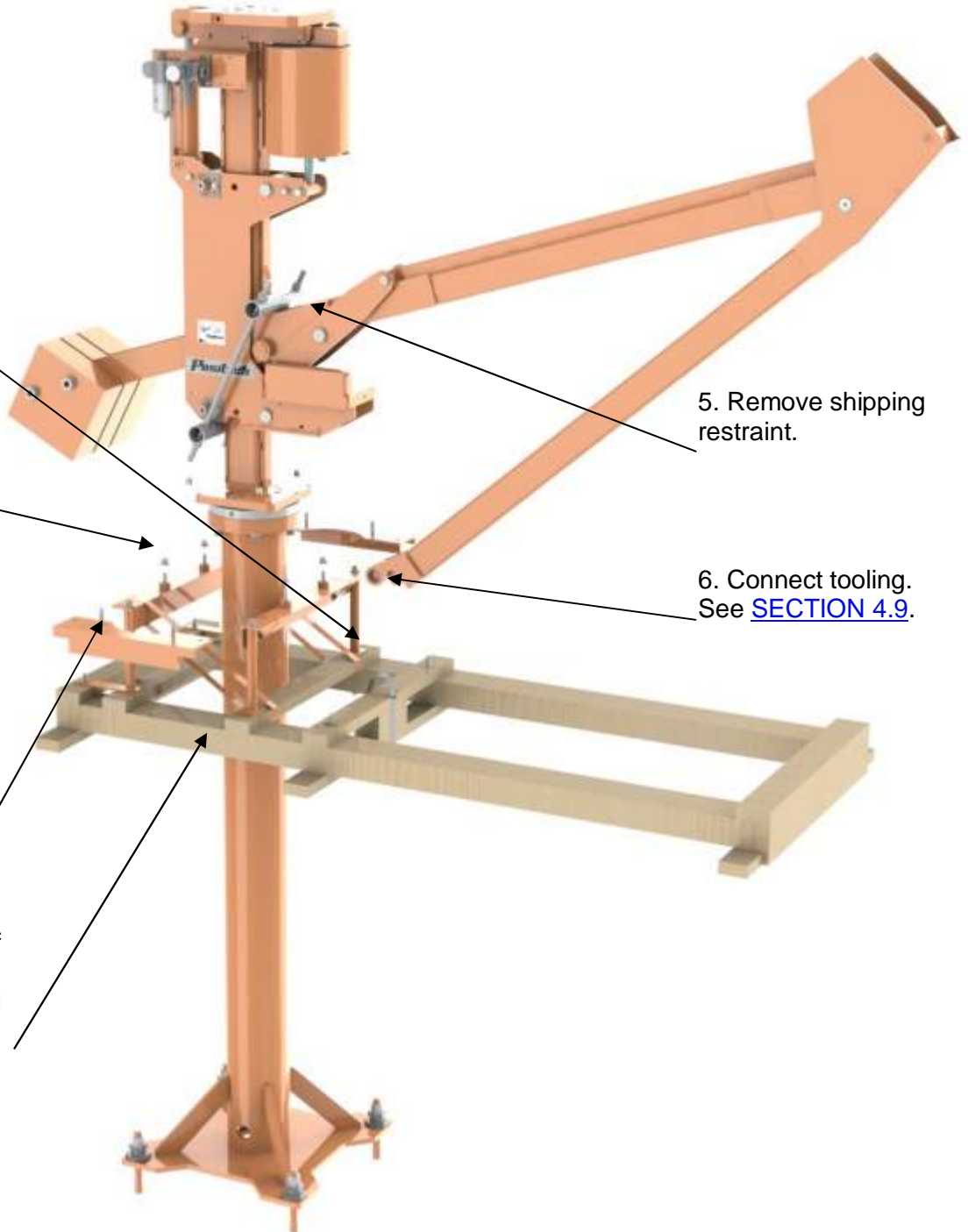

4.9 INSTALLING TOOLING (U-FRAME) FROM FACTORY:

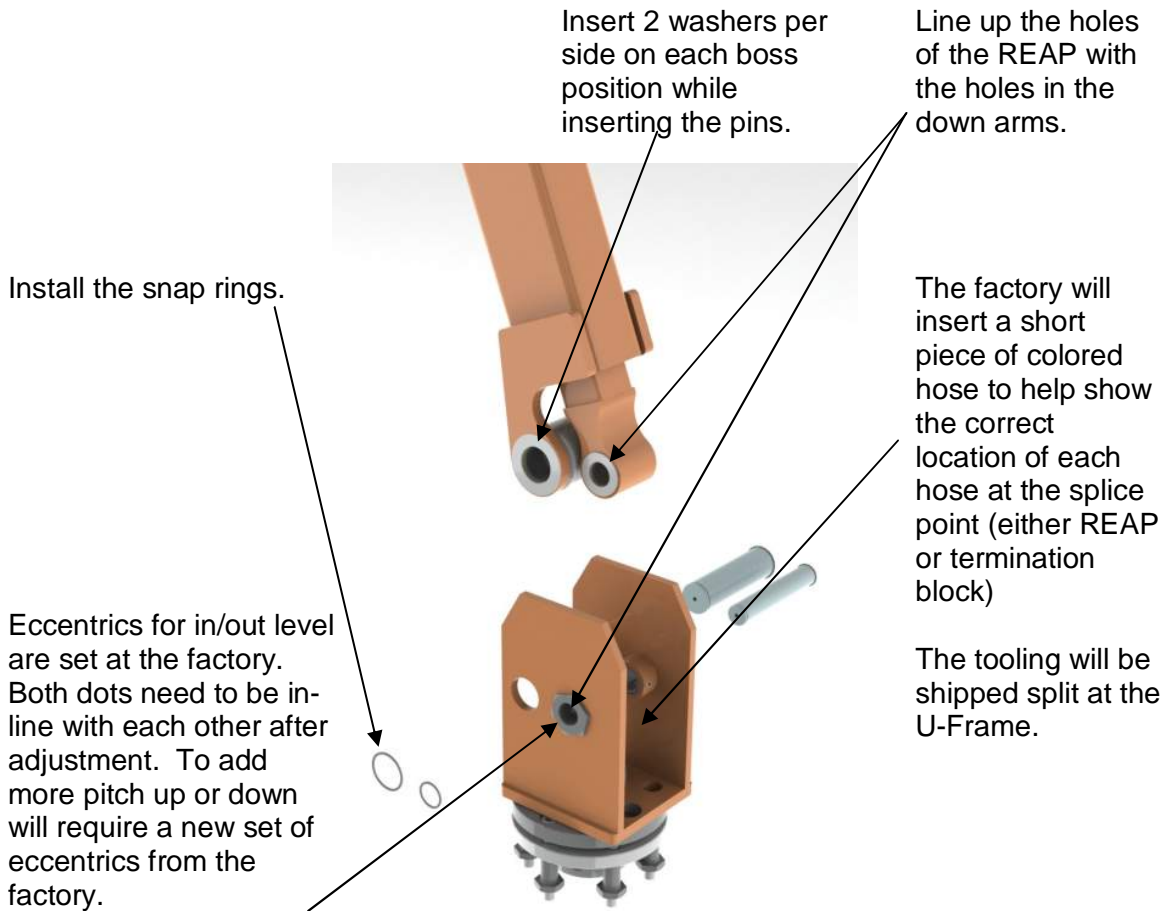

SECTION 5 - MAINTENANCE, ADJUSTMENTS, & INSPECTIONS:

Maintenance, adjustments, and inspections fall into three categories: every lift, frequent, and periodic.

- **Every lift evaluations:** are visual examinations completed by operator before and during each lift.
- **Frequent evaluations:** are visual examinations completed by the operator or designated persons with records not required. The period to complete these evaluations is based on a service rating of normal (monthly), heavy (weekly), or severe (daily) as explained below.
- **Periodic evaluations:** are visual examinations completed by qualified personnel completing records of apparent external condition to provide a basis for continuing evaluation. The period to maintain these records is based on a service rating of normal (yearly), heavy (semiannually), or severe (quarterly) as explained below.

Normal Rating	Heavy Rating	Severe Rating
Below 65% of rated load	65% to 100% of rated load	At 100% of rated load
Operate in an industrial environment free of aggressive contaminants	Operate in an industrial environment free of aggressive contaminants	Operate in abnormal environment
Life of manipulator is 2,000,000 cycles	Life of manipulator is 1,000,000 cycles	Life of manipulator is 500,000 cycles
For a manipulator that is outside these conditions refer to the profile drawing and/or consult the factory for specific instructions.		

EVERY LIFT EVALUATIONS

- Remove excess debris from surface of the load.
- Verify grip pad or vacuum cup is free of contaminant. Replace if excessively worn.
- Check the condition of the operator's controls and gauges on controls
- Verify the load is secure after actuation of tooling and before moving the manipulator.

FREQUENT EVALUATIONS

- Move the manipulator in and out and around each axis and check for free motion. Check bearing seals for leakage or damage. Replace any bearings that need to be replaced.
- Check friction devices, linkages, and other mechanical parts for excess wear and replace as needed. Check drag brake pucks for excessive wear.
- Clean and lubricate roller shelf and vertical guide rollers.
- Check welds on structural members for cracks. Look for cracked or missing paint over a weld. If welds are torn from the base steel, cracked, or broken the manipulator should not be used until repaired or determined safe. Consult factory for solution.
- Check structural members for deformations. Consult factory for solution.
- Check pivoting points and hook points for excessive wear and replace as needed.
- Replace missing guards, fasteners, covers, stops, decals, warning labels, or nameplates.
- Check for loose fasteners, especially set screws, and retighten. (ie. REAP nut)
- Check for leaks. Inspect condition and routing of all external hoses. Replace any leaky components or cracked hoses.
- See [SECTION 5.1](#) for lubrication schedule.
- Operating the manipulator: Check that all functions are in adjustment, that all automatic mechanisms functions properly, and that no functions interfere with current operation of the work cell.

PERIODIC EVALUATIONS

- Complete the frequent evaluations along with the following evaluations.
- Check anchor bolts and re-torque to 90 ft-lbs [122 Nm]. See [SECTION 4.2](#) for detailed views.
- Check air supply to manipulator. See profile drawing for required pressure and flow.
- Check spacer mounting bolts if overhead mounted and torque to 83 ft-lbs [112 Nm]. See [SECTION 4.3](#) for detailed views.
- Check main post mounting bolts and torque to 300 ft-lbs [408 Nm]. See [SECTION 4.6](#) for detailed views.
- Inspect main post bearing. Replace if a variation of .015 inch [.381 mm] is observed in the overall thickness of the bearing. Re-torque bearing mounting bolts to 300 ft-lbs [408 Nm].
- Check REAP mounting nut and set screws. If set screws are loose, nut and set screws need to be retightened.
- Check for worn or cracked gears, pulleys, sheaves, sprockets, bearings, chains, or belts and replace as needed.
- Check manipulator for level both in/out and around the main post and end joint. If the manipulator is level, the manipulator will not wander or wander very little. See [SECTION 5.8](#) for leveling the manipulator to eliminate drift in all operating quadrants.
- Check for oil leaks on lost load cylinder and verify lost load is functioning properly. See [SECTION 5.2](#) for lost load test, and [SECTION 5.3](#) for replacing lost load cylinder seals.
- Inspect lift cylinder pilot check valves. Inspect check valves on grip cylinder or vacuum check valves.
- Check GSC adjustment. Use empty tool and adjust GSC knob until an audible pop is heard. Screw in adjustment ¼ turn and tighten jam nut. Verify adjustment using a scrap part.

5.1 LUBRICATION SCHEDULE:

1. Remove lost load cylinder from manipulator and clamp vertically to add fluid.

2. Add hydraulic fluid under #10-32 screw on lost load valve. Cycle piston rod back and forth while filling.

Check lost load fluid level according to periodic schedule by removing #10-32 screw.

3. Be sure the stat-o-seal is on the screw when replacing the screw #10-32.

If manipulator does not lock on lost load test, see [SECTION 5.2](#). If significant oil loss is witnessed add hydraulic fluid and see SECTION 5.3 to change seals

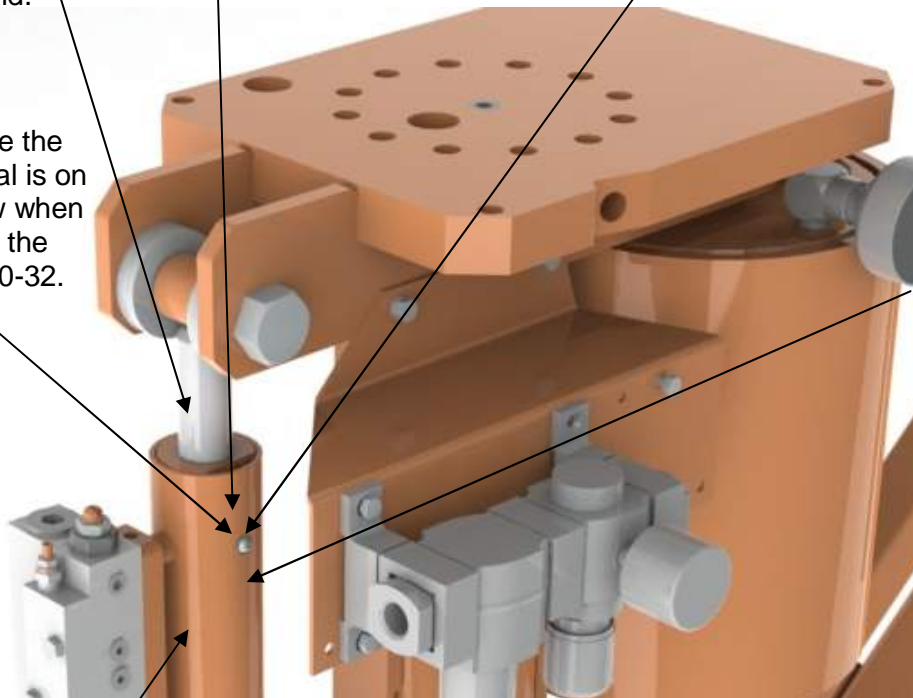

4. Reattach lost load cylinder to manipulator.

Use #2 Grease on RE/REAP 2 shots per periodic schedule – Do not over grease

Use #1 Grease on main post bearing 2 shots per periodic schedule – Do not over grease

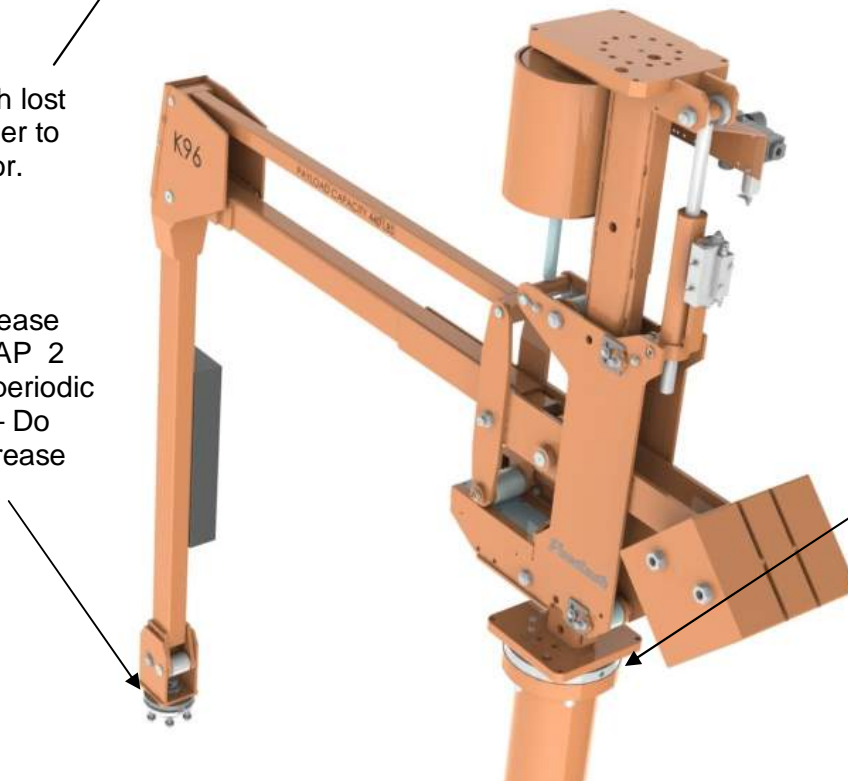

5.2 ADJUSTING A DUAL LOST LOAD LOCK VALVE:

The lost load device is designed to prevent rapid upward or downward travel of the arm if a sudden change of load should occur at the end of the arm.

5.2.1 UNLOCKING A LOCKED LOST LOAD CYLINDER:

Lower the arm slightly to lower the pressure in the cylinder and wait about 15 seconds. If it is locked due to a downward travel raise it slightly.

If the lost load valve is locking during normal operation the valve is too sensitive and needs to be adjusted.

5.2.2 CHECKING IF LOST LOAD WORKS PROPERLY:

- Remove any payload so that only the tooling is attached to the manipulator
- Adjust the up speed flow control to full open to allow maximum travel speed upward. Be sure to stand clear of the manipulator and tooling to avoid being hurt by the equipment.



- Depress the up button on the metering valve quickly. The manipulator should only raise a few inches before locking and rising slowly.
- To unlock the cylinder depress the down button until the manipulator stops moving upward and wait 15 seconds.
- Re-adjust the up speed to standard speed if the lost load valve worked properly.
- If the lost load valve did not lock properly, see the adjusting the lost load valve below.
- Re-test the lost load valve and make adjustments until the test is successful.
- **Re-adjust the up speed to standard speed when the lost load valve worked properly to complete the test.**

5.2.3 ADJUSTING A LOST LOAD VALVE THAT IS TOO SENSITIVE:

Loosen the chrome jam nut and back out (counterclockwise) the adjusting screw 1/8 turn. Without tightening the jam nut check the upward travel again for over-sensitivity as explained above. If Repeat until upward travel does not lock at normal operating speeds. Tighten the jam nut and re-check at normal operating speeds to make sure the adjustment is correct. To increase sensistivity follow the procedure by turning the adjusting screw in (clockwise) 1/8 turn at a time.

Adjusting screw
for down direction

Chrome jam nut

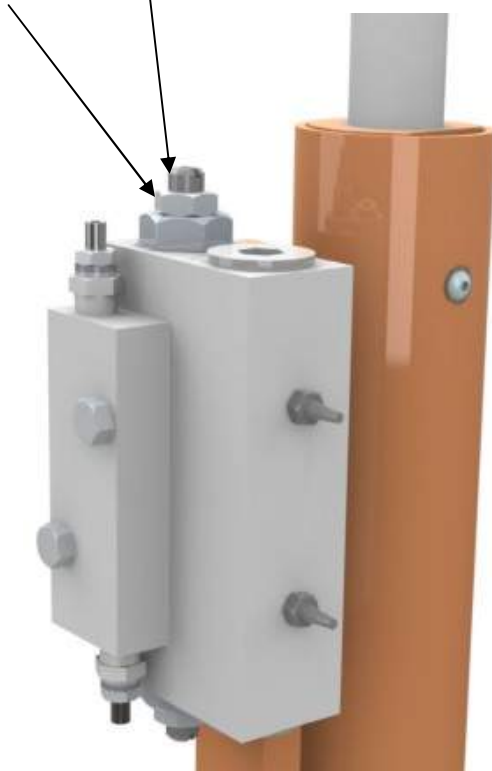

Chrome jam nut

Adjusting screw for up
direction



5.3 CHANGING SEALS IN THE DUAL LOST LOAD CYLINDER:

A replacement lost load cylinder can be purchased from the factory when the lost cylinder is leaking. This cylinder will be shipped less the lost load lock valve that is bolted on.

Lost load lock valve
8702500

Lost load cylinder
9420200 and seal
kit number K200003

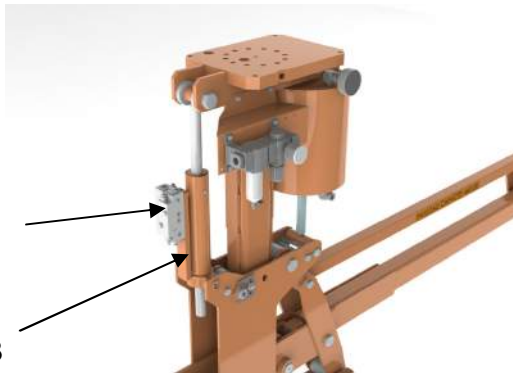

7. Lubricate the parts with light grease during installation and reverse disassembly steps 4 to 2.

8. Refill with hydraulic fluid and install the #10-32 screw with the stat-o-seal.

1. Drain the oil out of the cylinder by removing the #10-32 screw and cycling the piston rod two full cycles.

2. Remove the snap ring on the head and pull out the shaft, piston, and head. Be careful not to scratch the shaft.

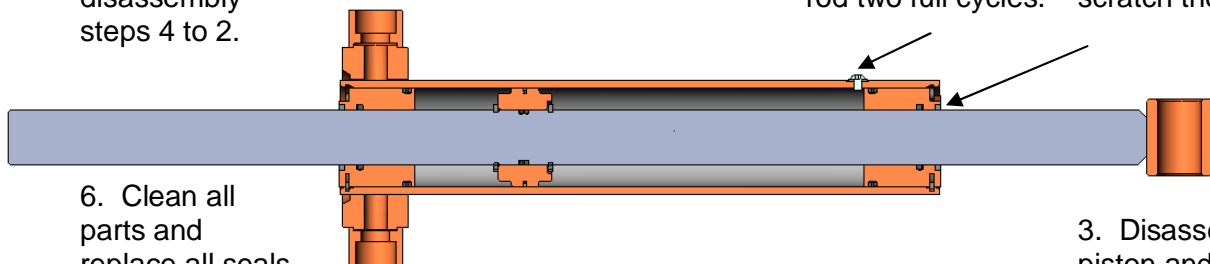

6. Clean all parts and replace all seals. Avoid over stretching seals.



3. Disassemble the piston and shaft assembly by removing the snap rings on the shaft.

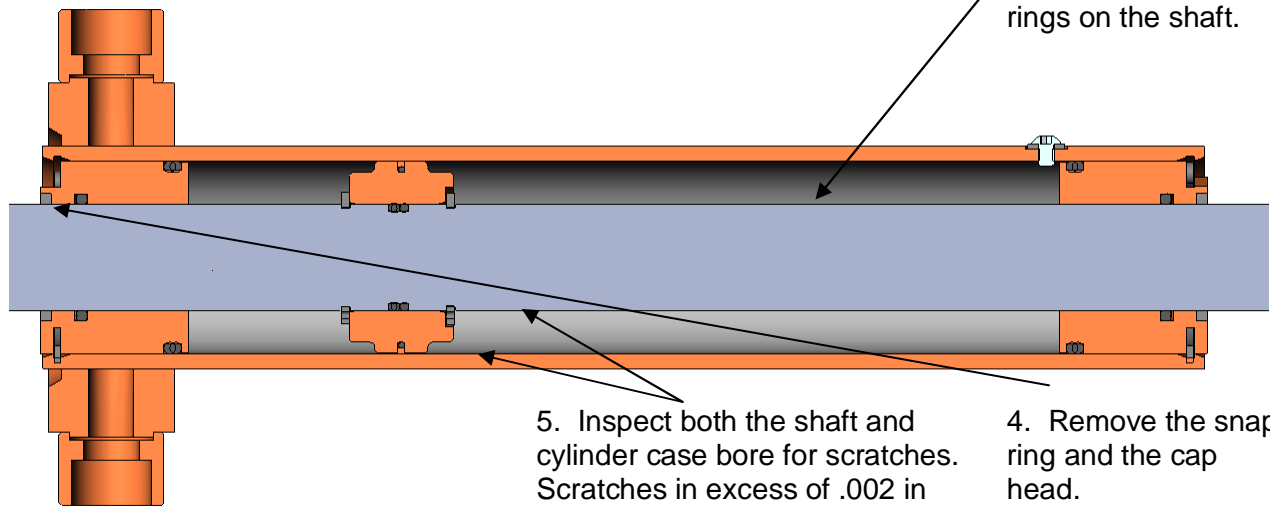

5. Inspect both the shaft and cylinder case bore for scratches. Scratches in excess of .002 in [.05mm] deep will require replacement.

4. Remove the snap ring and the cap head.

5.4 REBUILDING A PISTON TYPE LIFT CYLINDER:



1. Support the arm onto a rigid support before starting work. Also for a metering control system depress the down lever to bleed out all air pressure or for a balance system slowly unscrew the down “no load” regulator to bleed out the air.

2. After removing the air lines and cylinder pins, grip the trunion of the cylinder in a vise to support cylinder for disassembly.

3. Remove tie rod nuts. Torque tie rods to 35 ft-lbs [47 Nm] in a cross pattern.

When installing the U-Cup the open side goes toward the head.

8. Clean all parts and lubricate all seals with light grease for assembly. Replace all seals and bearing By reversing steps 6 to 2. Avoid over stretching seals.

7. Inspect the shaft and cylinder case bore for scratches. Scratches in excess of .002 in [.05mm] deep will require replacement.

Contact the factory for parts.

6. Remove the snap ring, bearing, and seal from head.

5. Disassemble the piston from the shaft by loosening the nut. Torque the locknut to 250 ft-lbs [340 Nm] with no thread lock or grease when reassembling.



4. Carefully pull out the head, shaft, and piston. Be careful not to scratch the case.

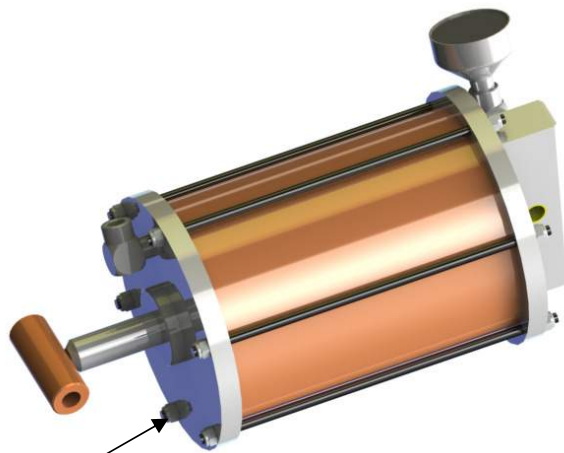
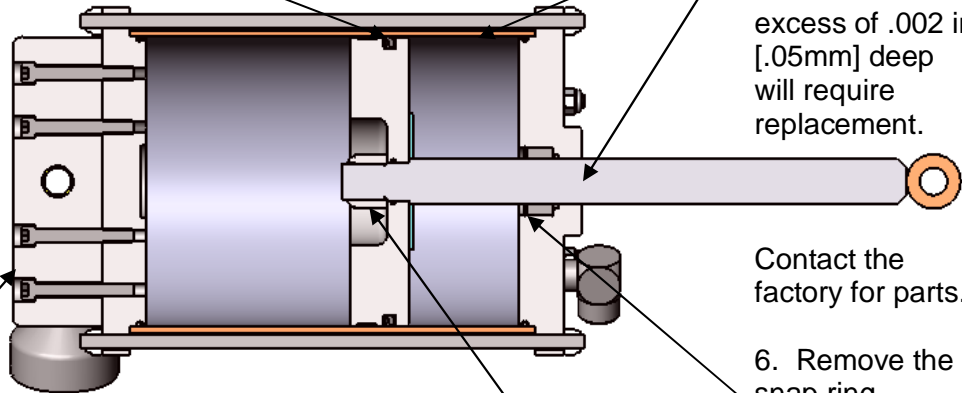

5.5 ADJUSTING THE FORCE LINK ROLLER:

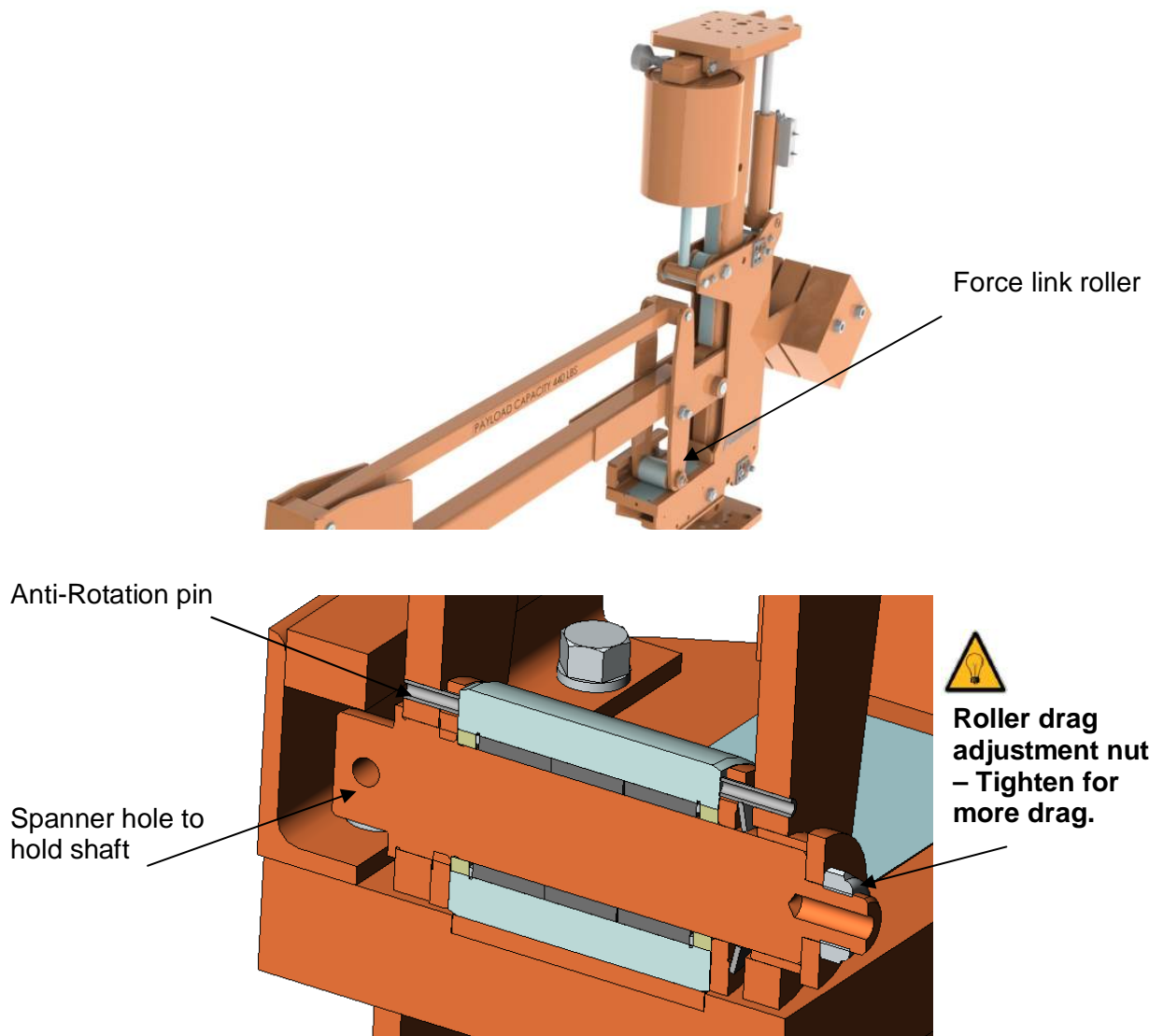

Note: Excess drag may be caused by the anti-rotation pin being installed too far. Allow .030 to .060 inches [.7 to 1.5mm] of clearance between pin and side of roller. If replaced, pins should be lightly tapped into place and cut off flush.

5.6 ADJUSTING THE LIFT HOUSING ROLLER ASSEMBLIES:

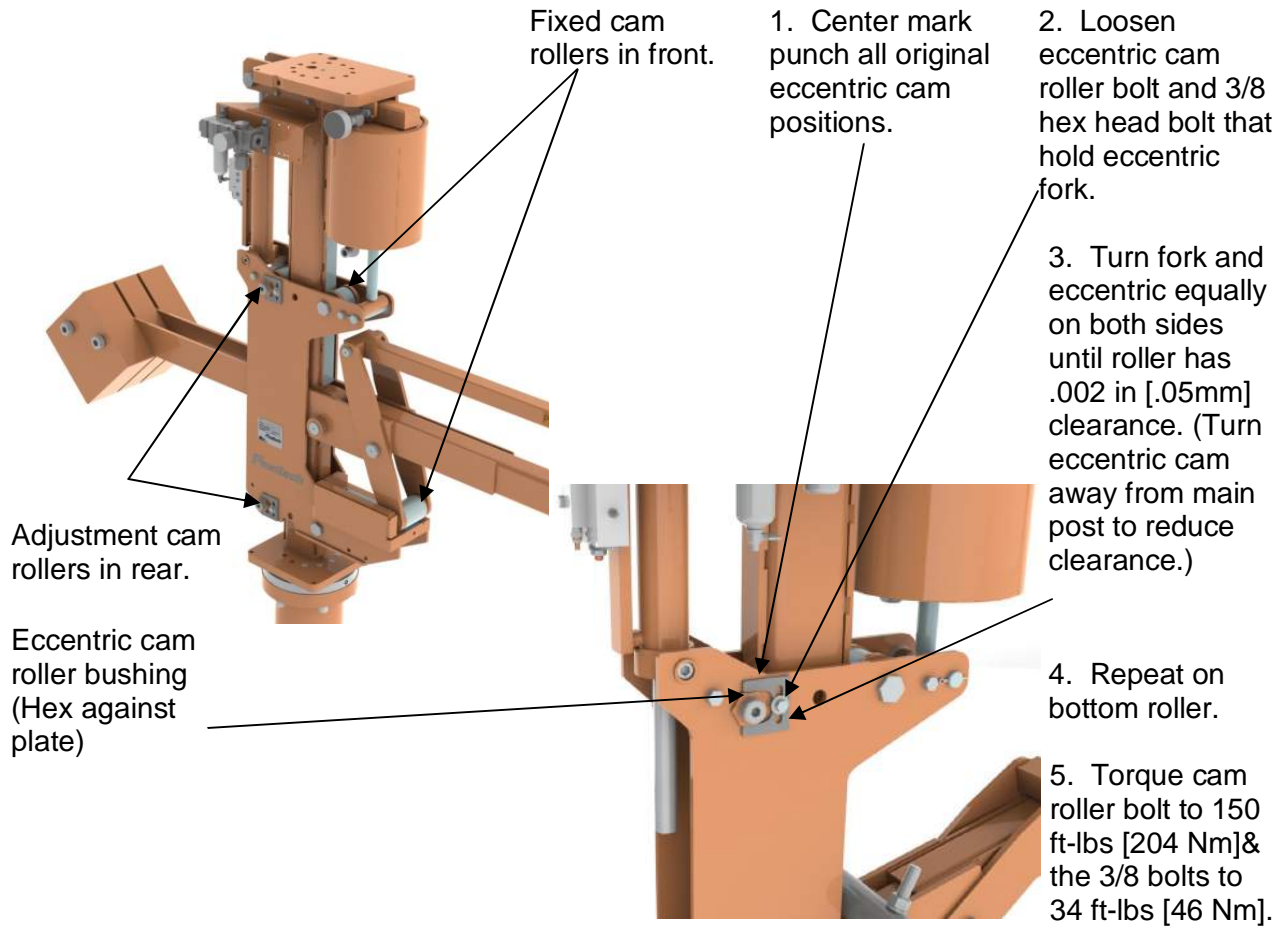

5.7 TIGHTENING THE ANCHOR BOLTS:

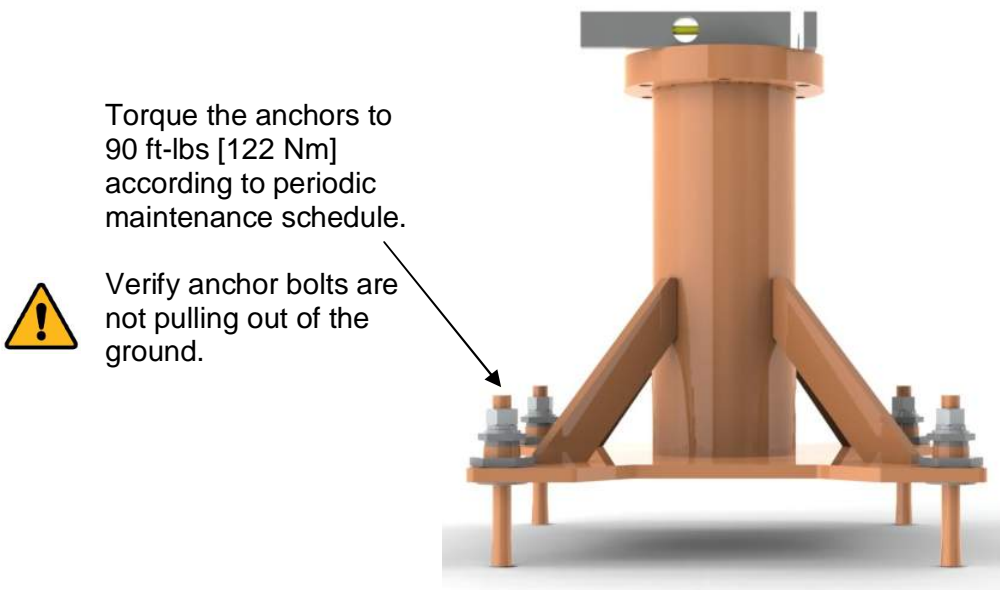

5.8 LEVELING THE PEDESTAL OR SPACER AFTER INSTALLATION:

See [SECTION 4.2](#) or [SECTION 4.3](#) for close up views of the pedestal and spacer jacks and all torque specifications.

1. Rotate arm perpendicular to one set of leveling jacks to start. Always keep the tooling parallel to the arm. During leveling always, maintain the same lift height.



Note: Never move the level during leveling.

2. Place a level on the base plate of the main post. This is not a machined surface so the level does not need to read level.

3. Check the level at this position. Absolute level is not important but the change in level as the arm is rotated 90° and 180° from the current position is what is important.

7. Recheck the 90° and 180° positions that all are the same value on the level. If not repeat steps 4 through 6.

6. Rotate the arm 90° and check the change in the level. If the level is not the same, adjust the pedestal or spacer until the level matches the start position.

5. Rotate the arm back to the start position and recheck the level. The level may not read level but the same value of level as in position 2. If the two values of level are not the same repeat step 4.

4. Rotate the arm 180° and check the change in the level. If the level is not the same, adjust the pedestal or spacer to split the difference between the level value at positions 1 and 2.

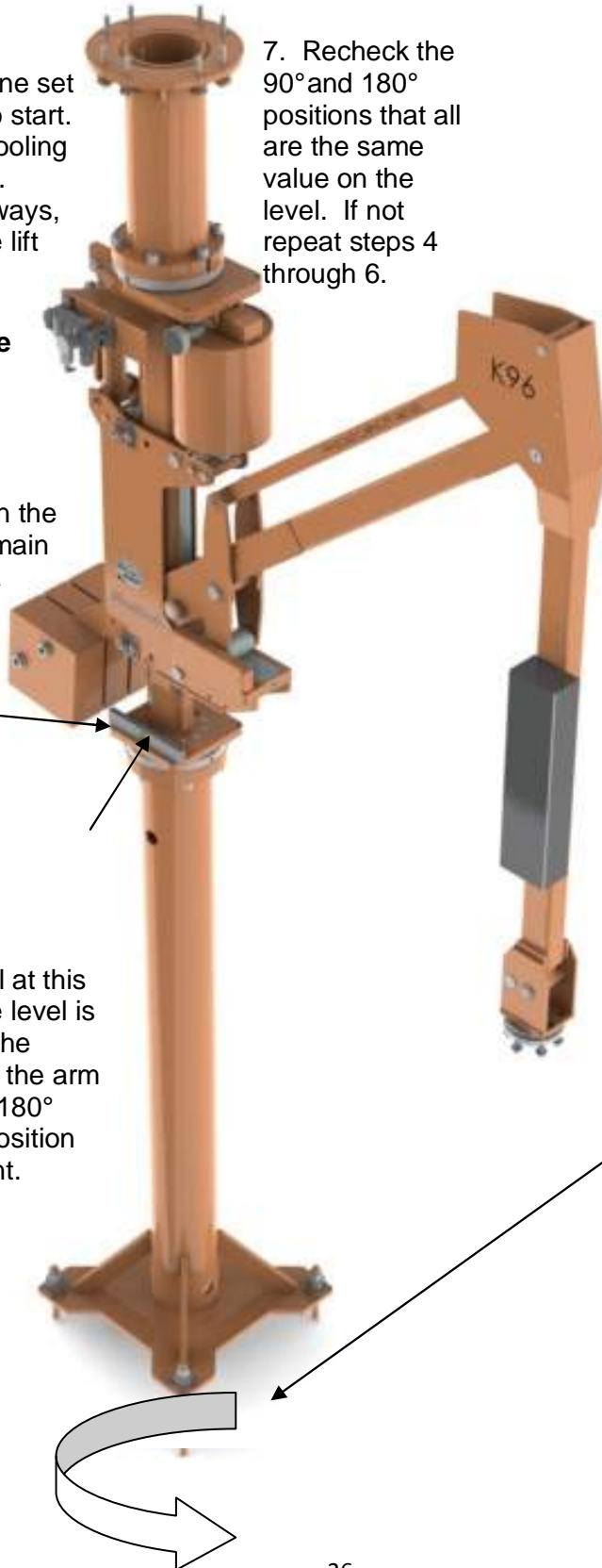

5.9 AIR LINE SIZING FOR SUPPLY AIR

Note: See profile drawing for required flow and pressure.

SCFM	Length of run in feet, Air line size in inches								
FLOW	25	50	75	100	150	200	300	500	1000
6	½	½	½	½	½	½	½	¾	¾
18	½	½	½	¾	¾	¾	¾	1	1
30	¾	¾	¾	¾	1	1	1	1 ¼	1 ¼
45	¾	¾	1	1	1	1	1 ¼	1 ¼	1 ¼
60	¾	1	1	1	1 ¼	1 ¼	1 ¼	1 ½	1 ½
90	1	1	1 ¼	1 ¼	1 ¼	1 ¼	1 ½	1 ½	2
120	1	1 ¼	1 ¼	1 ¼	1 ½	1 ½	1 ½	2	2
150	1 ¼	1 ¼	1 ¼	1 ½	1 ½	2	2	2	2 ½

SLM	Length of run in meters, Air line size in mm								
FLOW	7.5	15	25	30	45	60	90	150	300
150	13	13	13	13	13	13	13	19	19
500	13	13	13	19	19	19	19	25	25
580	19	19	19	19	25	25	25	32	32
1250	19	19	25	25	25	25	32	32	32
1700	19	25	25	25	32	32	32	38	38
2500	25	25	32	32	32	32	38	38	51
3400	25	32	32	32	38	38	38	51	51
4200	32	32	32	38	38	51	51	51	64

SECTION 6 - TROUBLESHOOTING:

1. Machine does not move up or down
 - A. Check main air supply
 - B. Verify lost load cylinder isn't locked
 - C. Check main regulator
 - D. If used, check lift cylinder on/off switch
 - E. Check pilot to lock valve
 - F. Check lock valve
2. Drifts up
 - A. Check metering valve for leaks
 - B. Check GSC valve for leaks
 - C. If used, check 6 passage rotary manifold for leaks
 - D. Check balance setting
 - E. Check minimum lift setting
 - F. Check tool balance adjustment setting
3. Drifts down
 - A. Check metering valve
 - B. If used, check 6 passage rotary manifold for leaks
 - C. Check for leaky lift cylinder seal, blocking valve connection
 - D. Check white poly lines for leaks
4. Main post rotation difficult
 - A. Check for main post bearing wear
 - B. If used, check drag brake adjustment
 - C. Check rails on trolley systems
5. Linear drift
 - A. Check main post level
 - B. Verify counter weights are correct
 - C. Check vertical guide rollers for out of adjustment
 - D. Check U-frame eccentrics
 - E. Check horizontal roller assembly
6. Grip release without being supported
 - A. Check GSC setting
 - B. If used, check 6 passage rotary manifold for leaks
 - C. Verify proper hose connections
 - D. Check bleed down speed
7. Linear movement difficult
 - A. Check horizontal roller and shelf
 - B. Check drag brake adjustment
 - C. Check pivot pins or bushings for wear
 - D. Check force link pivot pins or bushings for wear
 - E. Verify manipulator is level
8. Oil discovered near main post
 - A. Check lost load cylinder for leaks
 - B. Verify FRL lubricator is not set too high
 - C. Check FRL
9. Up/Down movement difficult
 - A. Check balance regulator adjustment
 - B. Verify horizontal arms are not rubbing on lift housing
 - C. Check lift cylinder and muffler
 - D. Check lost load cylinder
 - E. Check vertical cam eccentrics
 - F. Verify supply pressure and sufficient flow
10. Rotation drift at tooling
 - A. Check main post level
 - B. Check anchor bolts on main post
 - C. Check that end joint eccentrics are set equal

SECTION 7 - DRAWINGS:

**SECTION 8 - RECOMMENDED SPARE PARTS:
SECTION 9 -**