



**OWNER'S SERVICE MANUAL
NO. 05607
INSPECTION, MAINTENANCE AND RECHARGE**

WARNING: DO NOT USE THESE EXTINGUISHERS ON FIRES INVOLVING ENERGIZED ELECTRICAL EQUIPMENT (CLASS C HAZARDS), FLAMMABLE METALS (CLASS D HAZARDS) OR ANY FLAMMABLE THAT WILL REACT WITH WATER. PROTECT FROM FREEZING!

All fire extinguishers should be installed, inspected and maintained in accordance with the National Fire Protection Association standard titled "Portable Fire Extinguishers", NFPA-10 and the requirements of local authorities having jurisdiction.

When maintenance is indicated it should be performed by trained persons having proper equipment. Fire extinguishers are pressure vessels and must be treated with respect and handled with care. They are mechanical devices and require periodic maintenance to be sure that they are ready to operate properly and safely. Amerex strongly recommends that the maintenance of portable fire extinguishers be done by a trained professional – your local authorized Amerex Distributor.

Amerex Corporation makes original factory parts available to insure proper maintenance – use of substitute parts releases Amerex of its warranty obligations. Amerex parts have machined surfaces and threads that are manufactured to exacting tolerances. O-rings, hoses, nozzles, horns and all metal parts meet precise specifications and are subjected to multiple in-house inspections and tests for acceptability. There are substitute parts available that are incorrectly labeled as UL component parts, some are advertised as Amerex type. None of these meet UL requirements and all of them void the Amerex extinguisher warranty and UL listing. DO NOT SUBSTITUTE.

RECHARGE FIRE EXTINGUISHERS IMMEDIATELY AFTER ANY USE

REFERENCES IN THIS MANUAL
NFPA-10 Portable Fire Extinguishers

CGA C-1 Methods for Hydrostatic Testing
of Compressed Gas Cylinders
CGA C-6 Standard for Visual Inspection
of Compressed Gas Cylinders

AVAILABLE FROM
National Fire Protection Association
P. O. Box 9101
Quincy, MA 02269-9101

Compressed Gas Association
1235 Jefferson Davis Hwy, Suite 501
Arlington, VA 22202

AMEREX CORPORATION – P.O. BOX 81 – TRUSSVILLE, ALABAMA 35173-0081
Phone: 205/655-3271 Fax: 800/654-5980
e-mail: sales@amerex-fire.com Web Page: <http://www.amerex-fire.com>

FOAM FIRE EXTINGUISHERS
MODEL 254- 6 LITER AFFF FOAM WITH SPRAY NOZZLE
Model 250 – 2 ½ GAL.LON AFFF FOAM WITH ASPIRATED NOZZLE
MODEL 252 – 2 ½ GAL.LON FFFP (ALCOHOL RESISTANT) FOAM WITH ASPIRATED NOZZLE

AMEREX CORPORATION DOES NOT SERVICE, MAINTAIN OR RECHARGE FIRE EXTINGUISHERS. THE MAINTENANCE AND RECHARGE PORTION OF THIS MANUAL IS PUBLISHED AS A GUIDE TO ASSIST SERVICE PERSONNEL IN THE INSPECTION, MAINTENANCE AND RECHARGE OF AMEREX FIRE EXTINGUISHERS ONLY. NO INSTRUCTION MANUAL CAN ANTICIPATE ALL POSSIBLE MALFUNCTIONS THAT MAY BE ENCOUNTERED IN THE SERVICE OF FIRE EXTINGUISHERS. AMEREX ASSUMES NO LIABILITY FOR SERVICE, MAINTENANCE OR RECHARGE OF FIRE EXTINGUISHERS BY PUBLISHING THIS MANUAL.

INSPECTING THE EXTINGUISHER

This extinguisher should be inspected at regular intervals (monthly or more often if circumstances require) to insure that it is ready for use.

INSPECTION (NFPA-10) A "quick check" should be made of the extinguisher for the following:

1. Located in designated place.
2. No obstructions to access or visibility.
3. Operating instructions on nameplate (label) and facing outward.
4. Seals and tamper indicators not broken or missing.
5. Determine fullness by weighing or "hefting".
6. Examine for obvious physical damage, corrosion, leakage or clogged nozzle.
7. Pressure gauge reading in the operable area.

MAINTENANCE – SERVICE PROCEDURE

MAINTENANCE (NFPA-10) At least once a year (or more frequently if indicated by an inspection), maintenance should be performed. Maintenance is a "thorough check" of the extinguisher. It is intended to give maximum assurance that an extinguisher will operate effectively and safely. It includes a thorough examination and any necessary repair or replacement. It will normally reveal the need for hydrostatic testing.

1. Clean extinguisher to remove dirt, grease or foreign material. Check to make sure that the instruction nameplate is securely fastened and legible. Inspect the cylinder for corrosion, abrasion, dents or weld damage. If any of these conditions are found and you doubt the integrity of the cylinder, hydrostatically test, using the proof pressure method and a suitable cage, in accordance with CGA Pamphlet C-1 and NFPA Pamphlet 10. **NOTE:** When cleaning avoid use of solvents around the pressure gauge. They could seriously damage the plastic gauge face.
2. Inspect the extinguisher for damaged, missing or substitute parts. Only factory replacement parts are approved for use on Amerex fire extinguishers.
3. Check the date when last recharged. **The foam charge must be replaced every three years with the proper Amerex charge (model 502 AFFF charge for models 250 and 254, model 504 FFFP for model 252).** If the extinguisher is to be hydrotested do not reuse the charge even if within a three year cycle (the foaming action will make it almost impossible to get complete charge back into the extinguisher).
4. Weigh extinguisher and compare with weight printed on the Maintenance section of the nameplate (label). Recharge extinguisher if weight is not within the indicated allowable tolerances.

5. Check the date of manufacture on the extinguisher hanger loop or on the extinguisher nameplate. Cylinder must be hydrostatically tested every 5 years to the test pressure indicated on the label.
6. Visually inspect the pressure gauge:
 - a. If bent, damaged or improper gauge, depressurize and replace
 - b. If pressure is low, check for leaks
 - c. If over pressurized (overcharged), depressurize (discharge) and follow recharging instructions.
7. Inspect the footstand (base). If cracked or broken replace with proper footstand.
8. Inspect ring pin for freedom of movement by breaking the seal and removing the pin. Replace the ring pin if bent or if removal is difficult.
9. Inspect discharge lever for dirt or corrosion that might impair freedom of movement. Inspect carrying handle for proper installation. If lever, handle or rivets are damaged or distorted, replace with proper Amerex part(s).
10. Remove hose assembly, inspect hose assembly for damage, replace as necessary. Blow air through hose assembly to insure passage is clear of foreign material.
11. Inspect the valve assembly for corrosion or damage to hose thread connections. Replace valve assembly or component parts as necessary following the proper depressurization and recharge procedures.
12. Install hose and nozzle assembly.
13. Install new tamper seal and record service data on the extinguisher inspection tag.
14. Rehang the extinguisher on the wall hanger bracket making sure that it fits the hanger bracket properly – replace the bracket if necessary.

RECHARGE

RECHARGING is the replacement of the extinguishing agent and includes the expellant for this type of extinguisher.

THE FIRE EXTINGUISHING AGENT IN THIS EXTINGUISHER MUST BE COMPLETELY REPLACED EVERY THREE YEARS. Use only the Amerex Model 502 AFFF or Model 504 FFFP concentrate charge to retain the UL approval and manufacturer's warranty. Substitute charges could make the extinguisher less effective.

WARNING:

- a. Before attempting to recharge be sure this extinguisher is completely depressurized.
- b. Use a regulated nitrogen pressurizing source. Set the regulator no more than 125 psi (862 kPa) higher than the gauge operating pressure.
- c. Check and calibrate regulator gauge at frequent intervals. The regulator gauge should be used to determine when the intended charging pressure has been reached. Do not use the extinguisher gauge for this purpose.
- d. Never leave an extinguisher connected to a regulator of a high pressure source for an extended period of time. A defective regulator could cause the cylinder to rupture due to excessive pressure.

RECHARGING PROCEDURE

1. Complete the "Maintenance-Service Procedure", items 1 thru 11.
2. Discharge all remaining pressure and AFFF or FFFP solution.
3. Remove the valve assembly and disassemble by removing downtube assembly, spring and valve stem from the valve assembly. Remove the collar o-ring from the valve assembly. Remove collar o-ring from the valve and plastic fill tube from the cylinder.
4. Thoroughly rinse all parts with clean water and wipe dry with a soft cloth. Inspect the valve components and collar o-ring and valve stem. Lubricate the collar o-ring and small o-ring on the valve stem with Visilox V-711 (do not lubricate the valve stem seal). Inspect the downtube. If it is cracked or deformed replace with proper downtube (see Parts List). Inspect downtube o-ring, replace if necessary.
5. Rinse the cylinder with clean water and inspect the interior following CGA Visual Inspection Standard C-6.
6. Firmly replace the plastic fill tube. On an accurate scale:
 - a. Model 250 2-1/2 gal. AFFF Premix
 1. Fill cylinder with 2.43 gals. (9.20 liters) (20.24 lbs. [9.18 kg]) of clean tap or distilled water. Continue with steps b2. And b3.
 - b. Model 254 6 Liter AFFF Premix
 1. Fill cylinder with 1.52 gals. (5.75 liters) (12.65 lbs. [5.74 kg]) of clean tap or distilled water.
 2. Slowly add an Amerex 502 AFFF charge to the water. The liquid level should now be close to the bottom of the fill tube.
 3. If necessary add water very slowly to bring the liquid to this level.
 - c. Model 252 2-1/2 gal. FFFP Premix
 1. Fill cylinder with 2.2 gals. (8.33 liters) (18.32 lbs. [8.31 kg]) of clean tap water or distilled water.
 2. Slowly add an Amerex Model 504 FFFP charge to the water. The liquid level should now be close to the bottom of the fill tube.
 3. If necessary add water very slowly to bring the liquid to this level.
7. Install a "Verification of Service" collar around neck of cylinder. Install valve assembly to the cylinder and properly align. Shake the extinguisher to assure a thorough mix of the foam solution. **CAUTION:** HAND TIGHTEN THE VALVE COLLAR NUT 100-125 IN LBS. MAX. (1.15-1.44 KG/m). OVER-TIGHTENING WITH A WRENCH WILL DAMAGE THE VALVE.
8. Install a P/N 02141 Fill (Pressurizing) Adapter on the valve outlet (where the hose assembly attaches) and pressurize with nitrogen to 100 psi (690 kPa). The pressure regulator should be set to no more than 125 psi (862 kPa). Remove Fill Adapter.
9. Check the collar, gauge, cylinder welds and valve orifice for leaks using a leak detection fluid or a solution of soapy water. Remove leak detection fluid from the valve assembly by blowing out with air and wipe exterior of the extinguisher to dry.
10. Install hose assembly into the operating valve. Torque swivel nut lightly with a 15/16" wrench. Install in hose clip.

11. Install ring pin with ring facing front of the extinguisher. Install new tamper seal. Record recharge date and attach new recharge tag.
12. Weigh assembled extinguisher and confirm that the total weight is within the allowable tolerances indicated in the Maintenance section on the extinguisher nameplate (label).

TROUBLESHOOTING GUIDE

WARNING: Determine the source of a leak before the extinguisher is depressurized. THE EXTINGUISHER MUST BE COMPLETELY DEPRESSURIZED BEFORE ANY ATTEMPT IS MADE TO DEVALVE IT AND CORRECT ANY LEAKAGE PROBLEM. To depressurize – hold the extinguisher in an inverted position and slowly squeeze the discharge handle. Some liquid remaining in the downtube will be discharged so care should be taken in the area used for depressurization. Thoroughly clean all valve parts after depressurization and valve removal.

	PROBLEM	CORRECTIVE ACTION
1.	Leak at collar o-ring	Remove valve assembly, clean collar (knurled) nut thoroughly and install new o-ring. Lubricate the o-ring with Visilox V-711 (P/N 06247).
2.	Leak through valve	Install new valve stem assembly. Check valve seat for scratches or foreign matter.
3.	Leak around gauge threads	Remove gauge* and reinstall using Teflon tape on the gauge threads.
4.	Defective gauge	Remove defective gauge* and install a new gauge using Teflon tape on the gauge threads.
5.	Leak in the cylinder	Contact Amerex if under warranty, otherwise mark "Rejected" and return to owner.
6.	Broken footstand	Install new footstand (see parts list)
*	Pressure gauge threads are coated with a special epoxy at the factory. For easy removal soak the valve assembly (minus the downtube assembly) in hot water (180°F/82°C) for two to four minutes. Remove gauge with a 7/16" open end wrench.	



PARTS LIST

For

Model 254 – 6 Liter AFFF Foam Extinguisher
Model 250 – 2½ Gallon AFFF Foam Extinguisher
Model 252 – 2½ Gallon FFFP Foam Extinguisher

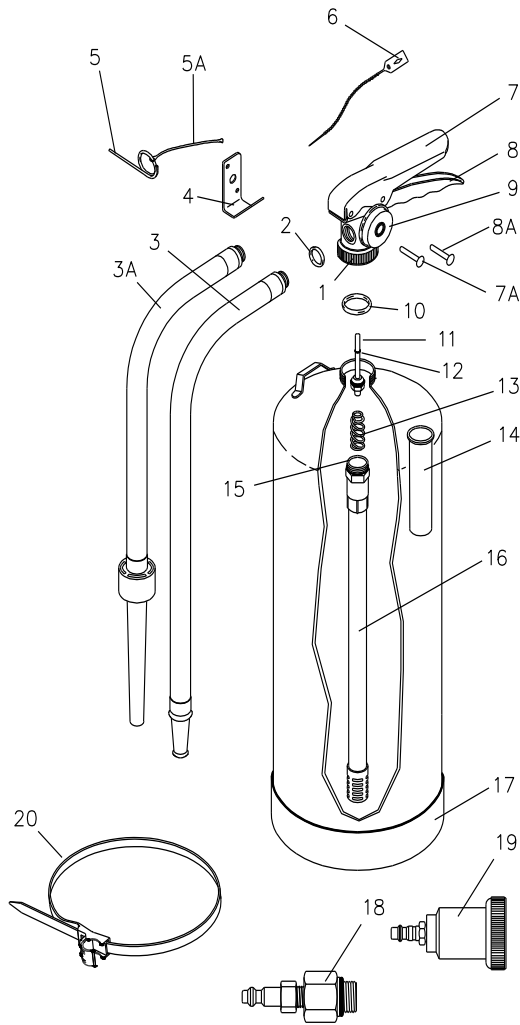

ITEM NO.	PART NO.	DESCRIPTION	STD PKG
1	14345	Valve Assembly	1
2	06978	Hose Gasket (O-ring)	24
3	13162	Hose & Spray Nozzle Asy – 254	1
3A	07000 06982	Hose & Aspirated Noz. Asy – 250 Hose & Aspirated Noz. Asy – 252	1
4	01007	Wall Bracket	6
5	00160	Ring Pin, Stainless Steel	24
5A	00532	Chain (Nylon) for ring Pin	24
6	01387	Lock Wire Seal (Yellow)	500
7	07762	Lever & Rivet	1
7A	01563	Rivet Only for Handle (2 required)	24
8	09020	Handle & Rivets	1
8A	01564	Rivet Only for Handle (2 required)	24
9	06479	Valve Stem Asy	6
10	05240	Collar O-Ring	24
11	06093	Valve Stem Assembly Valve Stem Assembly (bulk bag)	6 96
12	05243	Valve Stem O-Ring	24
13	00383	Spring	6
14	02595	Fill tube	1
15	05690	Downtube O-Ring	12
16	02581 02209	Downtube/Retainer Asy – 254 Downtube/Retainer Asy – 250, 252	1
17	03376 03109	Footstand w/Post (Black) – 250, 252 Footstand (Black) – 254	1
18	02141	Pressurizing Adapter	1
19	03181	Hydrotest Adapter	1
20	14776	Strap & Clip – 254	1
◆	02117	Model 502 AFFF Premix Charge – 250, 254	12
◆	06981	Model 504 FFFP Premix Charge – 252	12
◆	04488	Adhesive (Footstand) 3 oz. tube	1
◆	06247	Visilox Lubricant 5 oz. tube	1
NOTE:		All Valve Assemblies include new Valve Body, Pressure Gauge, Wing Nut Lever & Handle	
◆	PARTS NOT PICTURED		