

**THE COMPLETE  
OWNERS & SERVICE  
MANUAL**

**FOR THE  
UNIVERSAL ATOMIC 4  
GAS ENGINE**

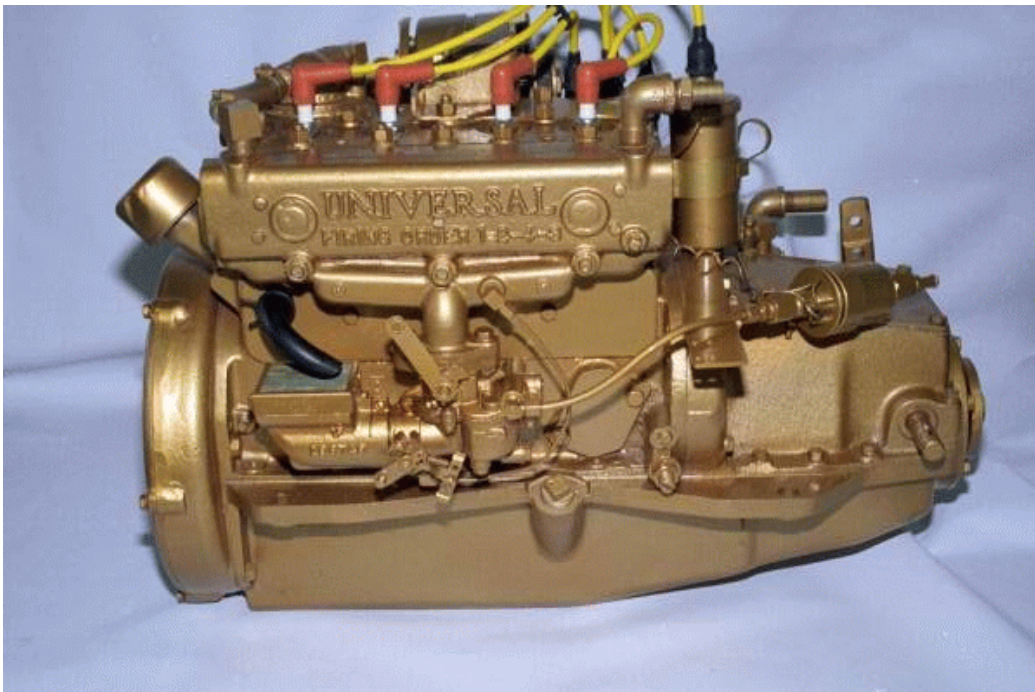

**Photo Courtesy of  
Jayne Boat Works  
St. Petersburg, FL  
[www.atomic4parts.org](http://www.atomic4parts.org)**

## **ENGINE OPERATION**

TO INSURE PROPER OPERATION OF YOU ENGINE AT ALL TIMES, IT IS WELL TO OBSERVE BASIC RULES. THIS IS ESPECIALLY TRUE DURING WINTER MONTHS WHEN THE BOAT IS EITHER IN STORAGE OR USED INFREQUENTLY.

SEE THE INSTRUCTION BOOK FOR PREPARING THE ENGINE FOR WINTER STORAGE. IN ADDITION TO FOGGING THE ENGINE, WE ALSO SUGGEST THAT OIL BE PLACED IN EACH CYLINDER AND THE ENGINE TURNED OVER THREE (3) OR FOUR (4) TIMES TO INSURE ADDED PROTECTION FOR THE VALVES DURING STORAGE.

DURING COLDER WEATHER WHEN BOATS ARE NOT USED REGULARLY, THE ENGINES REQUIRE EXTRA CARE AND ATTENTION. WHENEVER THE ENGINE IS PLACED IN OPERATION, IT SHOULD BE RUN UNTIL THE ENGINE IS THOROUGHLY WARMED UP TO NORMAL OPERATING TEMPERATURE AND THEN IT SHOULD BE OPERATED AT THIS TEMPERATURE FOR 15 TO 30 MINUTES. JUST STARTING AN ENGINE BRIEFLY CHANGES THE TEMPERATURE SLIGHTLY AND INDUCES CONDENSATION TO FORM. THIS CONDITION IS ONE OF THE MAIN CAUSES FOR STICKY VALVES.

IF THE BOAT WILL NOT BE USED FOR A MONTH OR SO, IT IS WELL TO FOG THE ENGINE AND PLACE OIL IN THE CYLINDERS. IT IS NOT ALWAYS POSSIBLE TO CLOSE THE EXHAUST AND THE VALVE MECHANISM IS EXPOSED TO SALT AIR BACKING UP THE EXHAUST PIPE. ALSO, CONDENSATION FORMS INTERNALLY DURING STORAGE. DO NOT JUST START THE ENGINE EACH WEEK OR SO AND RUN IT FOR A FEW MINUTES. SEE PRECEDING PARAGRAPH.

REMEMBER, YOUR BOAT IS IN THE WATER AND SUBJECT TO THE CORROSIVE ACTION OF SALT AIR AND WATER. PROBLEMS THAT MIGHT DEVELOP DUE TO IMPROPER CARE OR OPERATION IN THE FIELD CANNOT BE CONSIDERED AN ENGINE DEFECT AND ARE NOT COVERED BY THE NORMAL ENGINE WARRANTY.

IT IS IMPORTANT TO CHANGE OIL FREQUENTLY AS RECOMMENDED IN THE OWNERS MANUAL. CONTAMINATED OIL DOES NOT PROVIDE ADEQUATE LUBRICATION.

### **IMPORTANT NOTE:**

AT ALL TIMES, REGARDLESS OF FREQUENCY OF OPERATION, IT IS NOT GOOD PRACTICE TO RUN THE ENGINE FOR ONLY A SHORT PERIOD OF TIME. IT SHOULD BE OPERATED 30 MINUTES AT A VERY MINIMUM TO REACH NORMAL OPERATING TEMPERATURE.

IT IS ALSO GOOD PRACTICE TO OCCASIONALLY RUN THE ENGINE AT FULL LOAD FOR A PERIOD OF TIME (A MINIMUM OF 5 MINUTES) TO KEEP THE ENGINE CLEAN OF MOISTURE AND CARBON ACCUMULATIONS FROM SHORT RUN PERIODS OR LONG IDLE PERIODS.

NEVER START THE MOTOR UNTIL THE MOTOR COMPARTMENT HAS BEEN VENTILATED BY EITHER OPENING THE HATCH OR OPERATING THE BLOWER TO REMOVE ANY POSSIBLE FUEL FUMES.

## **MARINE ENGINE WARRANTY**

### **PRODUCT WARRANTY**

SELLER WARRANTS ALL PRODUCTS AND PARTS OF ITS OWN MANUFACTURE AGAINST DEFECTS IN MATERIAL OR WORKMANSHIP FOR A PERIOD OF ONE (1) YEAR FROM DATE OF SHIPMENT WHEN GIVEN NORMAL AND PROPER USAGE AS DETERMINED BY SELLER UPON EXAMINATION, AND WHEN OWNED BY THE ORIGINAL PURCHASER. COMPONENTS PURCHASED BY SELLER AS COMPLETE UNITS AND USED AS AN INTEGRAL PART OF SELLERS EQUIPMENT WILL BE COVERED BY THE STANDARD WARRANTY OF THE MANUFACTURE THEREOF. SELLER WILL REPAIR OR REPLACE F.O.B. ORIGINAL SHIPPING POINT (BUT NOT INSTALL) ANY PART OR PARTS OF ITS MANUFACTURE WHICH IN ITS JUDGMENT, SHALL DISCLOSE DEFECTS IN EITHER MATERIAL OR WORKMANSHIP. IF REQUESTED BY SELLER, PARTS FOR WHICH A WARRANTY CLAIM IS MADE ARE TO BE RETURNED TRANSPORTATION PREPAID TO OUR FACTORY. THIS WARRANTY BECOMES VOID IF ARTICLE CLAIMED TO BE DEFECTIVE HAS BEEN REPAIRED OR ALTERED IN ANY WAY OR WHEN THE ARTICLE HAS BEEN SUBJECT TO MISUSE, NEGLIGENCE OR ACCIDENT OR WHEN INSTRUCTIONS FOR INSTALLING OR OPERATING HAS BEEN DISREGARDED. WE MAKE NO OTHER WARRANTY EXPRESS OR IMPLIED, AND MAKE NO WARRANTY OF MERCHANTABILITY OF OF FITNESS FOR ANY PARTICULAR PURPOSE, AND THERE ARE NO WARRANTIES WHICH EXTEND BEYOND THE DESCRIPTION OF THE FACE HEREOF. NO EMPLOYEE OR REPRESENTATIVE IS AUTHORIZED TO CHANGE THIS WARRANTY IN ANY WAY OR GRANT ANY OTHER WARRANTY. THE REMEDIES HERE-IN-ABOVE AFFORDED TO THE PURCHASER ARE EXCLUSIVE OF ALL OTHER REMEDIES PROVIDED BY LAW. SELLER SHALL NOT BE LIABLE FOR INDIRECT OR CONSEQUENTIAL DAMAGES WHERE THE LOSS SUSTAINED IS OF A COMMERCIAL NATURE.

### **PRODUCT IMPROVEMENTS**

THE MANUFACTURER RESERVES THE RIGHT TO MAKE PRODUCT IMPROVEMENTS AT ANY TIME WITHOUT TAKING RESPONSIBILITY OR OBLIGATION TO MAKE SIMILAR CHANGES OR ADD SIMILAR IMPROVEMENTS ON ANY ENGINES DELIVERED PRIOR TO THOSE CHANGES.

### **WARRANTY REGISTRATION**

ENCLOSED WITH EACH ENGINE IS A WARRANTY REGISTRATION CARD. THIS CARD MUST CONTAIN THE OWNER'S NAME, ADDRESS, SERIAL NUMBER OF THE ENGINE, V-DRIVE AND REVERSE GEARS AND RETURNED TO MEDALIST BEFORE THE WARRANTY BECOMES EFFECTIVE. THIS WARRANTY REGISTRATION MUST TAKE PLACE WITHIN 24 HOURS AFTER RECEIPT OF THE ENGINE.

### **WARRANTY EXCLUSIONS**

THE FOLLOWING SERVICES AND EQUIPMENTS WILL NOT BE REIMBURSED UNDER THE WARRANTY:

1. REPAIRS DUE TO NEGLIGENCE, MISUSE, IMPROPER APPLICATION, ACCIDENT, RACING AND INSTALLATIONS THAT DO NOT MEET MINIMUM STANDARDS AS SET FORTH IN THE INSTRUCTION MANUAL.
2. TUNEUP OR ADJUSTMENT EXPENSES NEEDED FOR CLEANING OF FUEL SYSTEM COMPONENTS DUE TO CONTAMINATION.
3. DAMAGE OR LOSS TO PERSONAL PROPERTY, LOSS OF REVENUE, TOWING CHARGES, STORAGE FEES, FUEL AND TELEPHONE CALLS.
4. DAMAGES OR LOSSES RELATED TO HANDLING AND SHIPPING.
5. EXPENSES RELATED TO REPLACEMENT OF LUBRICANTS, ANTI-FREEZE OR SPECIAL ADDITIVES.
6. FAILURE DUE TO NOT FOLLOWING RECOMMENDED MAINTENANCE SCHEDULES.
7. ALL TRANSPORTATION CHARGES WILL BE THE OBLIGATION OF THE OWNER, SUCH AS FREIGHT, TRAVEL TIME, AND TOLLS.

8. WARRANTY ITEMS RETURNED TO THE FACTORY COLLECT WILL BE BILLED TO THE SHIPPER.

### **WARRANTY AUTHORIZATION**

PRIOR AUTHORIZATION IS REQUIRED FROM THE FACTORY WHERE COMPLETE REPLACEMENT OR OVERHAULING OF THE FOLLOWING IS NECESSARY:

COMPLETE ENGINE ASSEMBLY. CYLINDER HEADS OR ENGINE BLOCK. MARINE REVERSE GEAR OR V-DRIVE.

**GENERAL**

Models ..... UJ, UJS, UJR, UJSR, UJVD  
 Type ..... Vertical, 4 cycle, L-head  
 Number of Cylinders ..... 4  
 Bore and Stroke ..... 2-9/16" x 3-1/8"  
 Total Piston Displacement in cu. Inches ..... 64.46  
 Spark Plug ..... Champion J-8 14 mm.  
 Compression Ratio ..... 6.3 to 1  
 Engine Rotation ..... Counter-clockwise viewed from flywheel end  
 Reduction Gear Ratio ..... 2.04 to 1  
 V-Drive Reduction Ratios ..... 1.00 to 1, 1.29 to 1, 1.67 to 1, 2.0 to 1  
 Fuel ..... Standard Gasoline, 92-94 octane  
 Maximum Operating Angle ..... Approximately 12 to 15 degrees maximum  
 Length Overall in inches ..... UJVD - 35-13/16", UJ - 26-3/4", UJR - 31-15/16"  
 Height above crankshaft center line ..... 13-1/8"  
 Maximum Width in Inches ..... 18-1/4"  
 Offset - Crank to Prop shaft ..... 1.042"  
 Base Depth Below Center line in inches ..... 6"  
 Exhaust Flange National Pipe Thread Size ..... 1-1/4"  
 Water Inlet National Pipe Thread Size ..... 3/8"  
 Water Outlet National Pipe Thread Size ..... 3/8"  
 Fuel Pump Connection ..... 1/8" N.P.T.  
 Fuel Line - Copper Tubing ..... 5/16" O.D.  
 Weight of engine, net pounds ..... UJ-310, UJR - 330, UJVD - 335  
 Firing Order (No. 1 on Flywheel End) ..... 1-2-4-3  
 Inlet Valve Opens ..... 5 degrees before TDC  
 Inlet Valve Closes ..... 50 degrees after LDC  
 Exhaust Valve Opens ..... 45 degrees before LDC  
 Exhaust Valve Closes ..... 10 degrees after TDC  
 Dwell Angle ..... 31 to 34 degrees

**Brake Horsepower**

RPM	600	1000	1500	2000	2500	3000	3500
UJS-UJSR	4	7.1	11	15	18	—	---
UJ-UJR-UJVD	5	7.3	11.9	16.2	20	25	30

Carburetor - Zenith 68 Series .....	7/8"
Reversing Gear - Paragon .....	OXKB
Reduction Gear .....	Paragon
Electrical Equipment UJ-UJR .....	Standard - 12 volt 35 amp alternator
Piston Skirt Clearance .....	.0015 feeler to 5 lbs. Pull
Piston Ring Cap Clearance .....	.007 to .015
Connecting Rod End Play .....	.004 to .008
Crankshaft End Play - Maintained at front bearing only .....	.002 to .003
Valve seat angle .....	45 degrees
Oil pump drive end play .....	.001 to .003
Distributor point gap clearance .....	.018 to .020
Magneto Breaker Point.....	.014 to .018
Spark Plug Gap Clearance .....	.0035
Ignition Timing - breaker points just starting to open .....	TDC
Main Bearing Clearance - on Crankshaft .....	.001 to .0025
Piston Ring Side Clearance	
Compression Ring (top).....	0.0015      0.003
Compression Ring (middle) .....	0.001      0.0025
Oil Ring .....	0.001      0.0025
Piston Pin Clearance in Piston .....	0.001      0.0002
Connecting Rod Clearance (dia) .....	0.001      0.0025
(# on Rod toward camshaft)	
Valve Tappet Clearance, Intake hot .....	0.008
Valve Tappet Clearance, Intake cold .....	0.01
Valve Tappet Clearance, Exhaust hot .....	0.01
Valve Tappet Clearance - exhaust cold .....	0.012
Valve Seat Width - intake .....	1/32"
Valve Seat Width - exhaust .....	1/32"
Valve Seat Angle .....	45 degrees
Valve Stem Clearance, Intake .....	0.0025      0.0035
Valve Stem Clearance, Exhaust .....	0.0025      0.0035
Camshaft Gear Back Lash .....	0.002      0.004
Idler Gear Back Lash .....	0.002      0.004
Accessory Gear Back Lash .....	0.002      0.004
Oil Pump Gear Back Lash .....	0.003      0.005
Camshaft Bearing Clearance .....	0.0015      0.0025
Camshaft Bearing Journal .....	1.3745      +.0005
	-.0000

### TORQUE WRENCH TENSION

Flywheel Stud Nuts .....	35 ft. lbs.
Cylinder Head Stud Nuts .....	35 ft. lbs.
Connecting Rod Bolt Nuts .....	33 ft. lbs.
Main Bearing - Front.....	60 ft. lbs.
Main Bearing - rear .....	60 ft. lbs.
Manifold Studs .....	35 ft. lbs.
Spark Plugs .....	30 ft. lbs.

**Note to Atomic Stevedore Owners** - All instructions in this book apply equally to Atomic Four and Atomic Stevedore models. Where there is a difference in specifications or adjustments, it is so indicated.



FIGURE 1

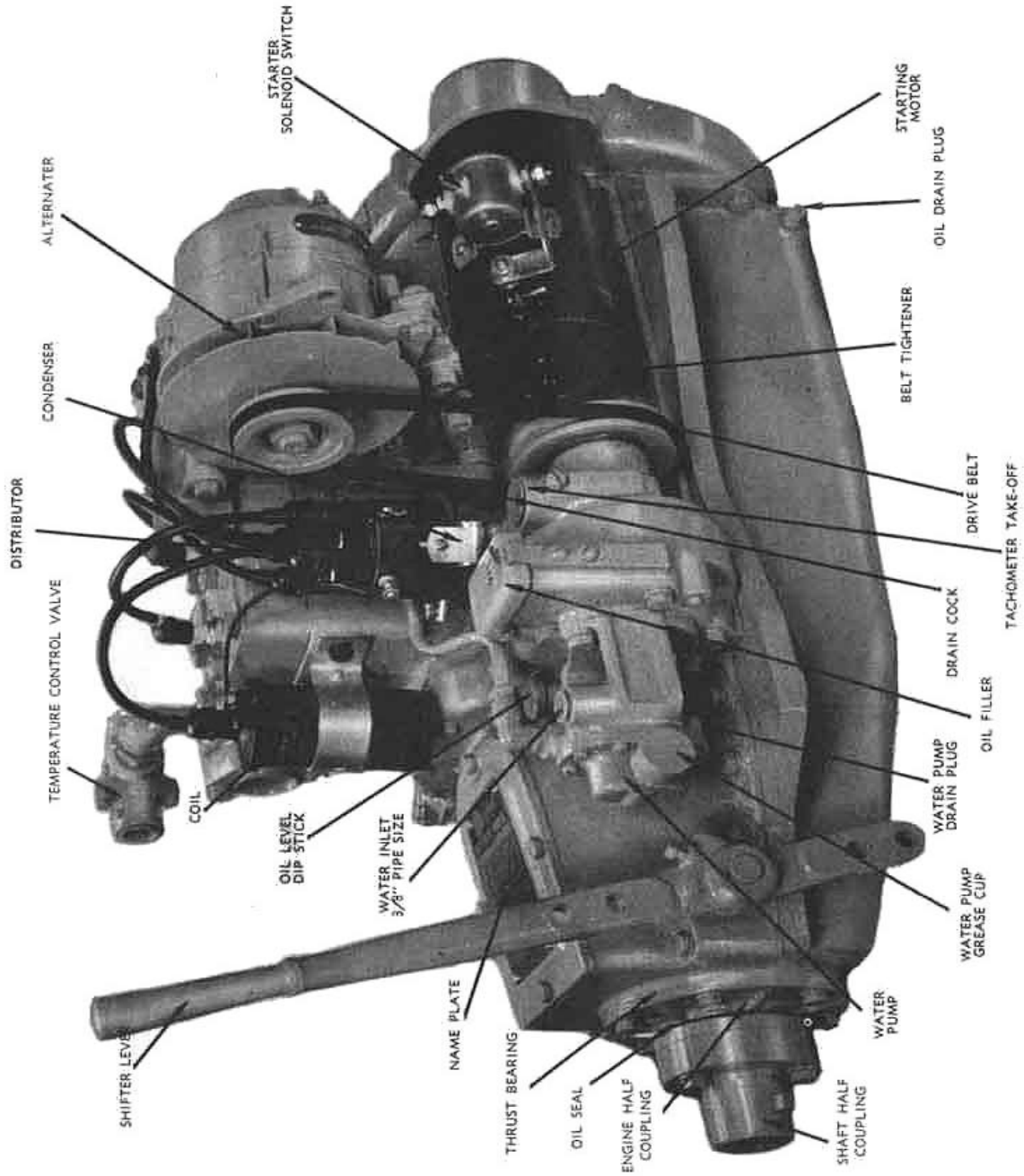
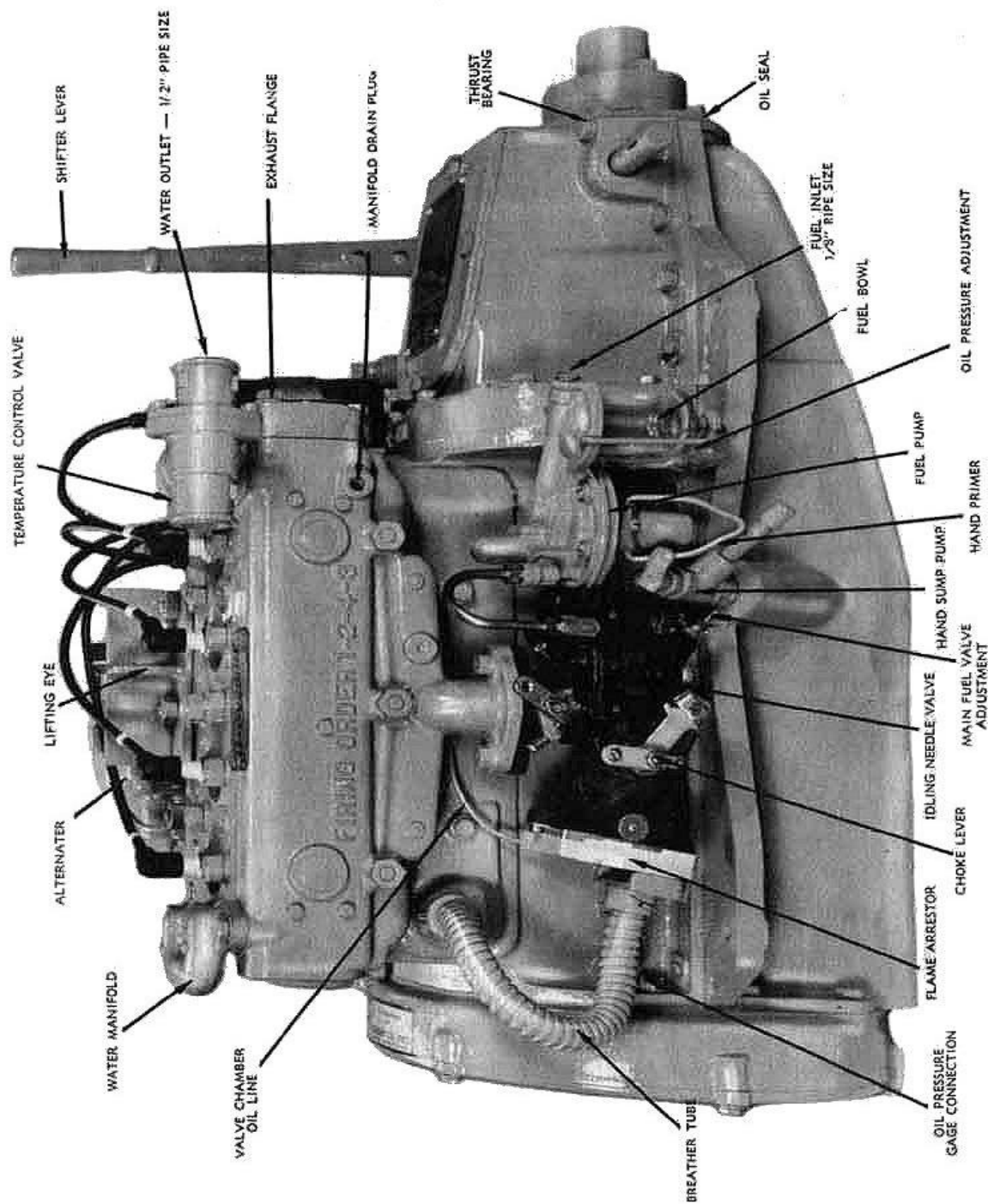

FIGURE 2



## GENERAL INSTRUCTIONS

Give your engine every chance to perform properly. If you become familiar with the operating requirements it will give you long dependable service. Check the alignment of the engine to the propeller shaft after the boat is first placed in the water. If you are in doubt how to proceed, write the factory for special service bulletin.

Add the necessary lubricating oil to the engine. The quantity is dependent upon the angle of installation and whether your engine is a direct or reduction drive model. Fill the oil base with 4 to 5 quarts of good grade SAE 30 detergent oil or until the dipstick shows full. The dipstick is located just forward of the water pump on the reverse gear housing. Check the oil level after the engine has been operated for a short time.

Check choke control to make sure choke valve fully closes. Then push choke back to normal position and make sure choke butterfly in carburetor fully opens. Check throttle control to make sure it provides for full movement of the throttle lever from idling position to fully open position.

Reversing gear controls must allow the clutch to lock in forward position and also into reverse position. Restricted or partial engagement will cause undue wear. Reversing gears and reduction gears are lubricated by the engine oiling system. Fuel line must be connected to fuel pump located just forward of reversing gear on carburetor side of the engine. A hand primer is provided to fill the fuel bowl for initial start. Use 5/16" copper tubing for fuel line.

An unrestricted water supply must be provided. Use a 1/2" through hull fitting with scoop forward. Locate scoop where it will have a supply of water at all times regardless of running position or rough seas. Water pump has 3/8" suction and manifold has 3/8" water outlet. Use non-collapsible hose for suction side.

Exhaust pipe is 1-1/4" iron pipe size. It should be installed without sharp bends and slope downward to its outlet to discharge water. The connection for discharge water should be at least 4" below the bottom of the manifold exhaust flange opening. See Figure 1.

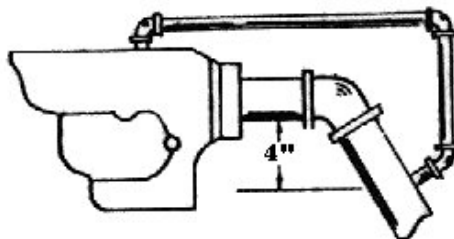

**Figure 1.**

**Suggestions before starting your new engine:**

**CAUTION: ENGINE IS SHIPPED LESS OIL. FILL WITH SAE 30 CLASS A DETERGENT OIL BEFORE STARTING.**

Ventilate engine compartment by opening hatches and starting blower fans if you have them.

Check fuel supply and make sure fuel lines are tight. Any fuel seepage or leaks should be corrected before you attempt to start engine.

Check all electrical connections. A wiring diagram for your particular model is included in this book. Ground is negative. Ground terminal should be attached to engine block.

Do not allow flames or sparks near battery openings. Gases produced during normal charging are explosive.

Make sure water pump is lubricated with water pump grease.

**Starting you new engine:**

1. Clutch lever should be in neutral position.
2. Fill fuel pump bowl using the hand primer on the fuel pump.
3. Place throttle lever at 1/4 open position.
4. Pull out choke rod.
5. Turn on ignition and start engine.
6. As soon as engine starts, gradually push in choke lever until choke valve is completely open.
7. Run engine at idling speed of 600 to 1000 rpm.
8. Check oil pressure - 45 to 55 pounds when engine is cold. Check oil after about 10 minute of running. Add oil to bring level to full mark if needed.
9. Check cooling system and make sure water pump is operating by checking water out of exhaust pipe. Temperature indicated on gauge should gradually go up to 140-160 degrees.
10. If oil pressure or water flow (or operating temperature) is not normal, stop engine at once and check installation to correct problem.
11. When shifting into forward or reverse position, engine should be running at 600-1000 rpm.

After the break-in period a good cruising speed for sail boat installations is about 2000 RPM or about 80% of the maximum engine speed obtainable.

### ZENITH MARINE CARBURETORS

61 Series - 1967 and before

1. Venturi
2. Main Jet
3. Main Dis. Jet
4. Well Vent- 5. Idling Jet
- 6. Idling Needle Valve
- 7. Throttle Plate
- 8. Idle Discharge Plug
- 9. Throttle Shaft
- 10. Restriction Bushing
- 11&11A - Pick up tube
- 12. Throttle stop screw (Not Illustrated)
- 13. Pick-up Tube metering orifice
- 14. Main jet adjustment
- 15. Idle fuel channel
- 16. Idle air channel

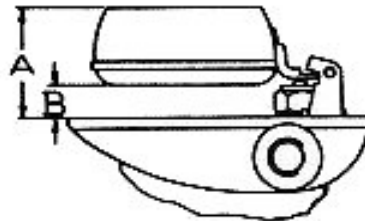

MODEL	Float Setting	
	A	B
61 M2AE7	1-9/64"	9/64"

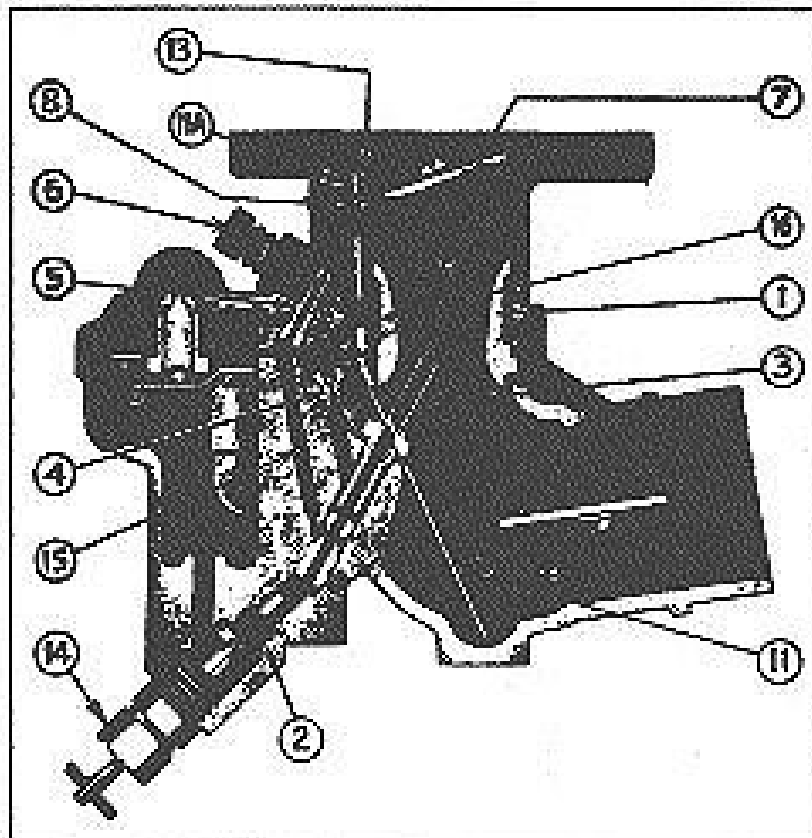

If the adjustments have been altered, start with a standard setting, which is:

1. Throttle stop screw - 1-1/2 turns (to right) from fully closed position of throttle plate (7).
2. Idling needle valve (6) one turn open (to left) from seat. The main jet adjustment (14) 2-1/2 turns open (to left) from seat.

## **ADJUSTMENTS**

If the engine, after running satisfactorily, suddenly ceases to perform properly, look over the intake manifold and the carburetor flange gaskets, throttle, choke and fuel connections. Make sure that throttle and choke valves open and close correctly and that fuel enters the carburetor in a free and steady stream. Do not change carburetor adjustments until other causes of trouble have been investigated.

Changes in adjustment should be necessary only with change in fuel or climate.

Before making any adjustments, warm up the engine thoroughly so that the intake manifold feels warm to the hand.

## **IDLE AND LOW SPEED ADJUSTMENT**

Close the throttle slowly until desired idling speed is reached.

Turn idling needle valve (6) gradually to right and left until the engine runs steady and as fast as this throttle position will permit.

Turning the idling needle valve to right (in) makes the mixture richer, to left (out) makes the mixture leaner.

If a satisfactory adjustment cannot be obtained, examine the idling jet (5) and the idle discharge plug (8) to make sure that dirt or water does not obstruct the free flow of the moisture through these parts.

After completing the adjustments set throttle stop screw (12) for desired idling speed.

## **INTERMEDIATE AND HIGH SPEED ADJUSTMENT**

The mixture at intermediate and high speed is controlled by the main jet (2), and the wall vent (4).

The main jet may be either of fixed size or adjustable. Whether fixed or adjustable, remove main jet (2) and blow out with compressed air or rinse in clean gasoline to remove water or dirt which may obstruct the metering orifice.

If adjustable, adjustment should be made as follows: (i) Open throttle about one-third; (ii) loosen packing nut on main jet adjustment (14); (iii) turn main jet adjustment to right (in) until the engine speed is noticeably reduced; (iv) turn main jet adjustment slowly to left (out) until the engine runs smoothly and as fast as this throttle position will permit; (v) hold needle valve in position and tighten packing nut after completing the adjustment.

Compensation is controlled by the well vent (4). A richer mixture, at high speeds is obtained with a smaller well vent and a leaner mixture with a larger well vent. If the mixture suddenly becomes too rich at high speeds, examine the well vent and make sure that it is not obstructed. Inspect these jets for water and dirt.

## **STARTING**

Open the throttle about one-quarter. Pull the choke control out all the way. Step on the starter. As soon as the engine starts, push the choke control in about one-third of the way and as the engine warms up, continue to push it in gradually until the choke valve is wide open.

## **FUEL LEVEL**

Correct setting of the float which controls the fuel level is of utmost importance. The fuel level is set at the factory for regular motor gasoline and a pump pressure of 2-lbs.per square inch.

## ZENITH 68 SERIES CARBURETOR

### OPERATION AND SERVICE

The Zenith 68 series carburetors are of updraft single venturi design. They are made in 7/8" and 1" S.A.E. barrel sizes; with 7/8" and 1" S.A.E. flange sizes. They are made with selective fuel inlet, and with or without a main jet adjustment.

These carburetors are "balanced" and "sealed", and the semi-concentric fuel bowl allows operation to quite extreme angles without flooding or starving. This design makes them particularly adaptable to smaller form tractors and a great variety of agricultural machines and industrial units.

### FUEL SUPPLY SYSTEM

The fuel supply system is made up of the threaded fuel inlet, the fuel valve seat, fuel valve need, float and fuel boat, as illustrated in Figure A.

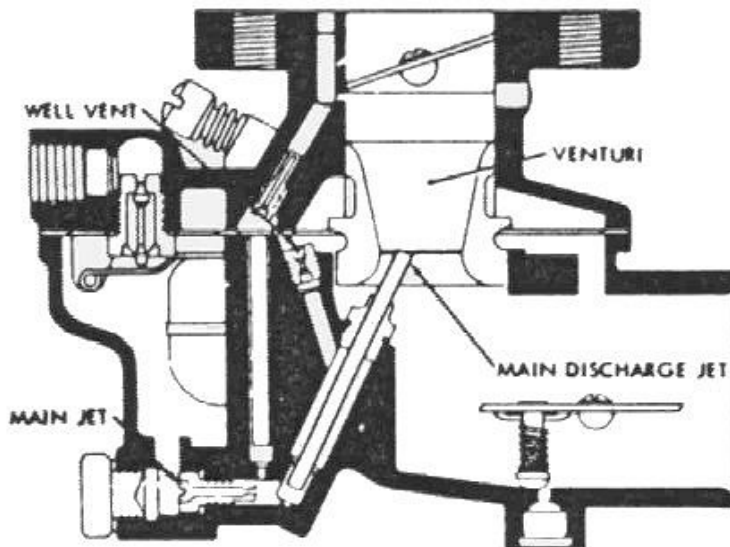

Figure A



The fuel supply line is connected to the threaded inlet. The fuel travels through the fuel valve seat and passes around the fuel valve and into the fuel bowl. The level of the fuel in the fuel chamber is regulated by the float through its control of the fuel valve. The fuel valve does not open and close alternately but assumes an opening, regulated by the float, sufficient to maintain a proper level in the fuel chamber equal to the demand of the engine according to its speed and load.

The inside bowl vent as illustrated by the passage originating in the air intake and continuing through to the fuel bowl, is a method of venting the fuel bowl to maintain proper air fuel mixtures even though the air cleaner may become restricted. This balancing is frequently referred to as an "inside bowl vent."

### IDLE SYSTEM

The idle system as shown in Figure B, consists of two idle discharge holes, idle air passage, idle adjusting needle, idle jet, and fuel pick-up passage.

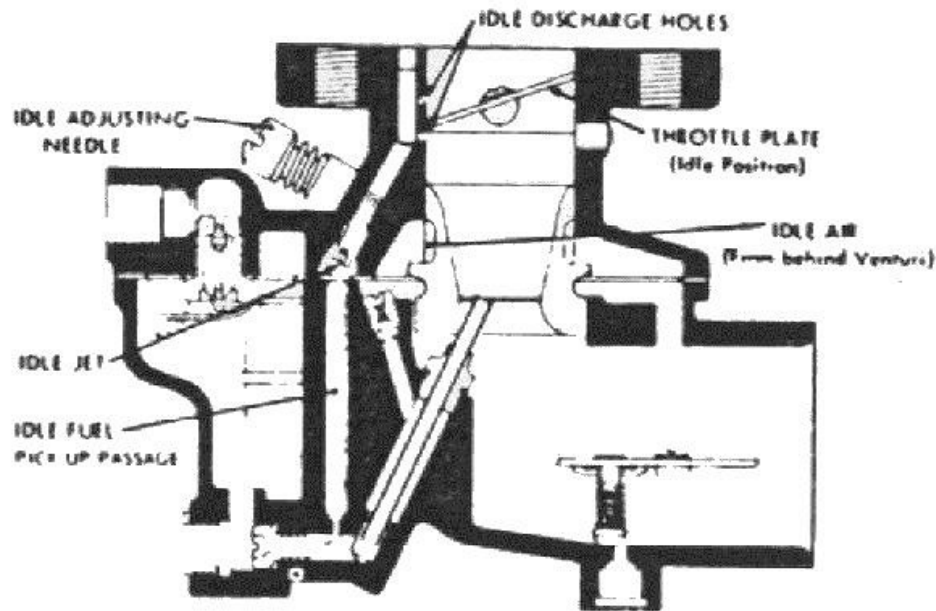

Figure B

The fuel for idle is supplied through the main jet to a well directly below the main discharge jet. The pick-up passage is connected to this well by a restricted drilling at the bottom of this passage. The fuel travels through this channel to the idle jet calibration. The air for the idle mixture originates back of (or from behind) the main venturi. The position of the idle adjusting needle in this passage controls the suction on the idle jet and thereby the idle mixture. Turning the needle in closer to its seat results in a greater suction with a smaller amount of air and therefore a richer mixture. Turning the needle out away from its seat increases the amount of air and reduces the suction, and a leaner mixture is delivered. The fuel is atomized and mixed with the air in the passage leading to the discharge holes and enters the air stream at this point.

### **HIGH SPEED SYSTEM**

The high speed system, Figure C., controls the fuel mixture at part throttle speeds and at wide open throttle. This system consists of a venturi, controlling the maximum volume of air admitted into the engine; the main jet, which regulates the flow of fuel from the float chamber to the main discharge jet; the well vent, which maintains uniform mixture ratio under changing suction and engine speeds; and a main discharge jet, which delivers the fuel into the air stream.

The main jet controls the fuel delivery during the part throttle range from one-quarter to full throttle opening. To maintain a proper mixture ration a small amount of air is admitted through the well vent into the discharge jet through the air bleed holes in the discharge jet at a point below the level in the metering well.

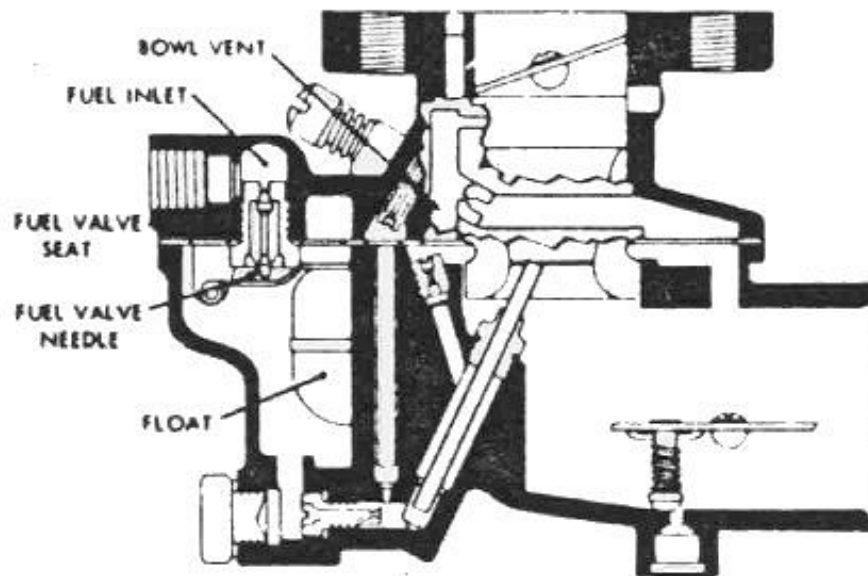

Figure C

At high speeds the fuel flows from the fuel chamber through the main jet and into the main discharge jet where it is mixed with air admitted by the well vent, and the air-fuel mixture is then discharged into the air stream of the carburetor.

### **CHOKE SYSTEM**

The choke system, consists of a valve mounted on a shaft located in the air entrance and operated externally by a lever mounted on the shaft. The choke valve is used to restrict the air entering the carburetor. This increases the suction on the jets when starting the engine. The choke valve is of a "semi-automatic" type, having a poppet valve incorporated in its design, which is controlled by a spring.

The poppet valve opens automatically when the engine starts and admits air to avoid overchoking or flooding of the engine. The mixture required for starting is considerably richer than that needed to develop power at normal temperatures. As the engine fires and speed and suction are increased, the mixture ratio must be rapidly reduced. This change is accomplished through adjustment of the choke valve and the automatic opening of the poppet valve to admit more air when the engine fires.

## FLOAT SYSTEM

The "A" dimension should be 1-5/32" plus or minus 3/64". Float Level. Check position or float assembly for correct measurement to obtain proper float level using depth gauge. NOTE: Do not bend, twist or apply pressure on the float bodies.

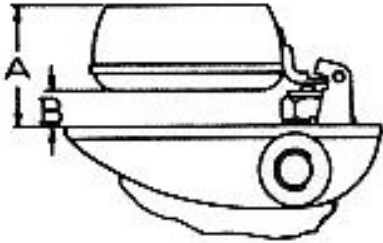

With bowl cover assembly in an inverted position, viewed from free end of float, the float bodies must be centered and at right angles to the machined surface. The float setting is measured from the machine surface (no gasket) of cover to top side of flat bodies at highest point.

Bending Float Lever. To increase or decrease distance between float body and machined surface use long nosed pliers and bend lever close to float body. NOTE: Replace with new float if position is off more than 1/16".

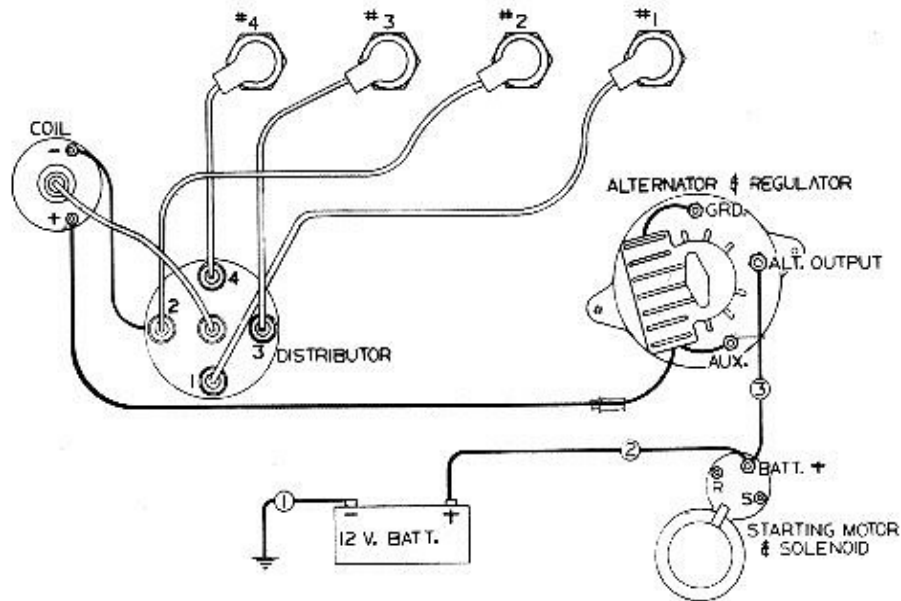
**ELECTRICAL SYSTEMS**

**Wiring Diagram - Motorola Alternator  
12-Volt, 35 Ampere, Solid State Regulator**

**NOTES:** Lead 1 is customer installed. Use min. of #1 heavy duty battery cable. This wire must be grounded back to engine.

Lead 2 is customer installed. Use min. of #1 heavy duty battery cable.

Lead 3 is customer installed. Use min of #8 wire. Do not install this wire if a panel mounted. Ammeter is used.

Alternator, regulator & starting motor are ground to engine at factory.

Alternator field is internally connected under regulator.

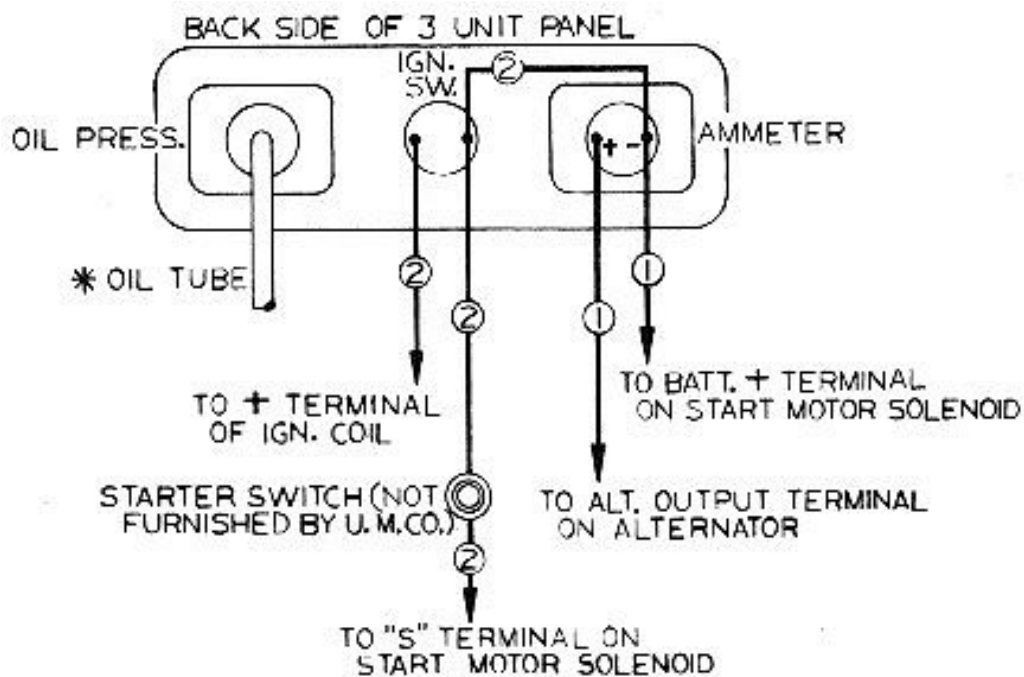

### Back side of 3 unit panel

NOTES: Leads 1 are customer installed. Use #8 GA. wire for circuits under 15 ft., #6 GA wire for circuits from 15 to 25 ft.

Leads 2 are customer installed. Use #16 GA wire for circuits under 15 ft., #14 GA wire for circuits from 15 to 15 ft.

\* When non-metallic flexible oil tube is used ground instrument panel directly to engine.

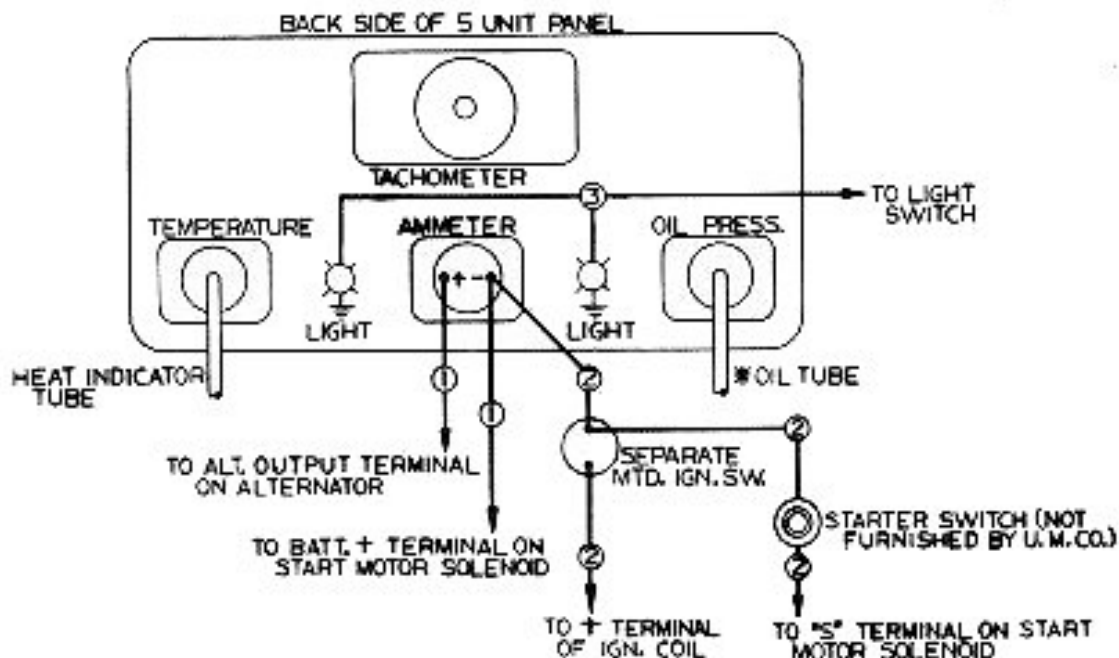

### 5 Unit Mechanical Instrument Panel Wiring Diagram

NOTES: Leads 1 are customer installed, use #8 GA wire for circuits under 15 ft., #6 GA wire for circuits from 15 to 25 ft.

Leads 2 are customer installed. Use #16 GA. wire for circuits under 15 ft., #14 wire for circuits from 15 to 25 ft.

Lead 3 is customer installed. Use #16 GA. wire, connect leads from panel lights to this wire.

\* When non-metallic flexible oil tube and heat indicator tube are used, ground instrument panel directly to engine.

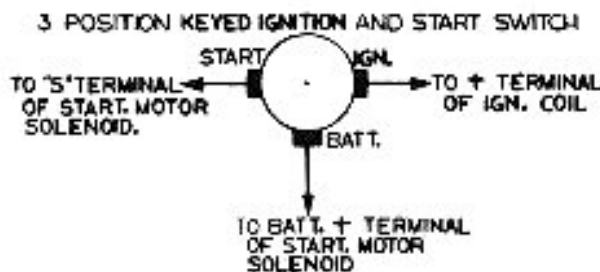

### Wiring Diagram - Prestolite Alternator - 12 Volt, 35 amp with Solid State Regulator

#### Recommended Minimum Wire Sizes For Connecting Alternator & Regulator

Total Length of of circuit in ft	'A' size wire	'B' size wire
15 ft or less	#8	#16
15 to 25 ft	#6	#14

#### Wire Chart for All Diagrams

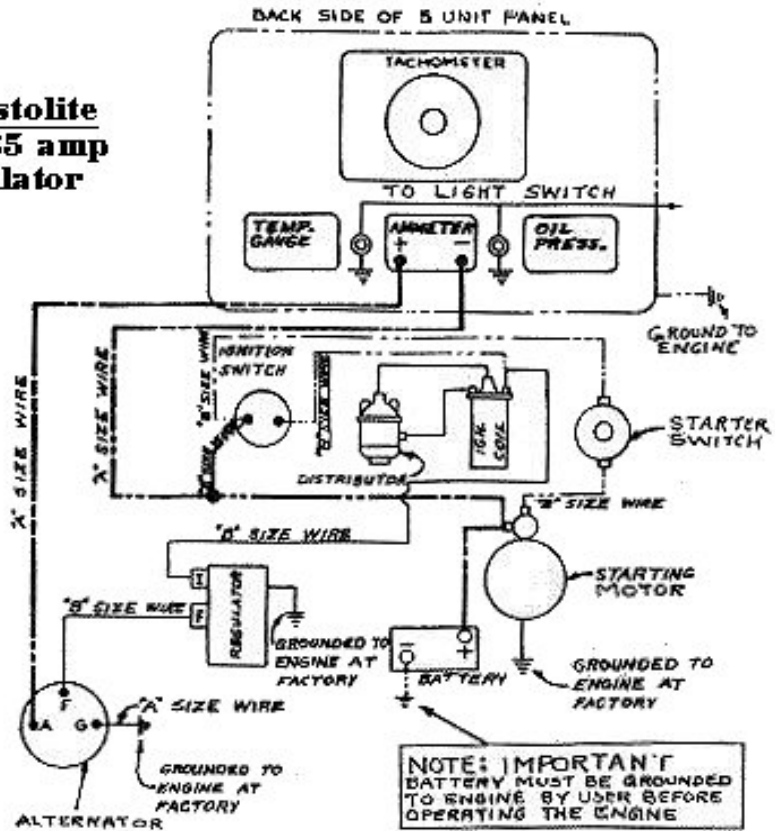



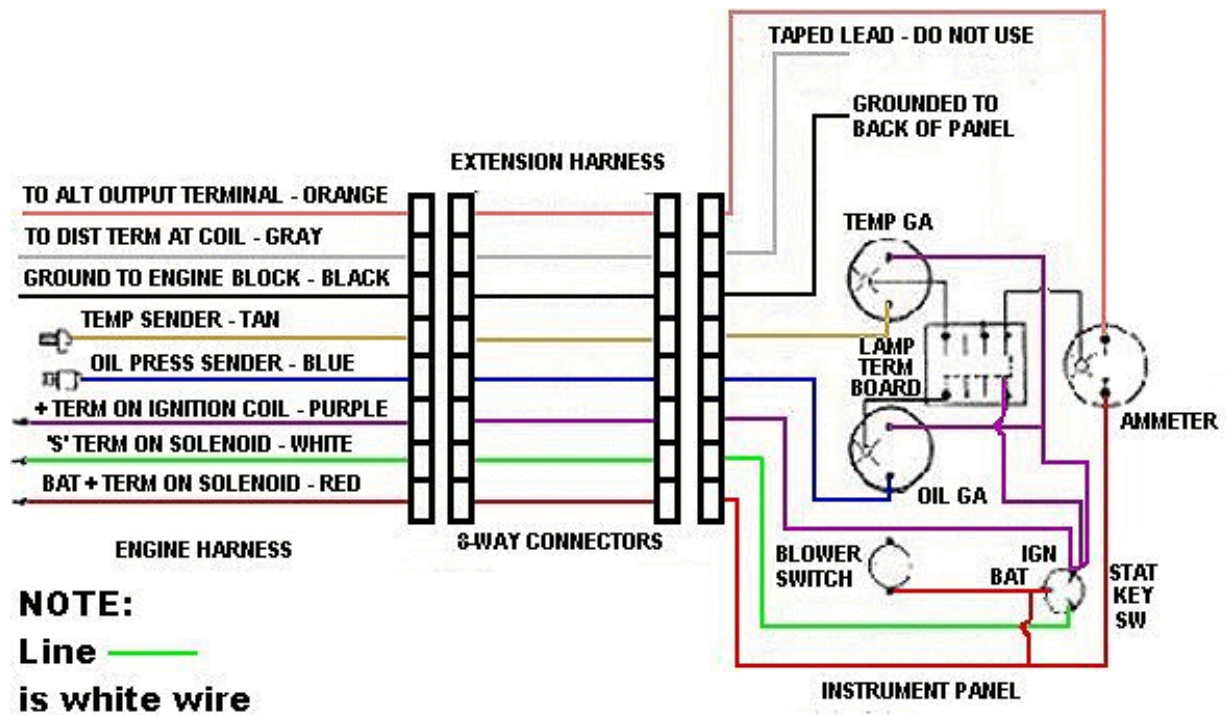
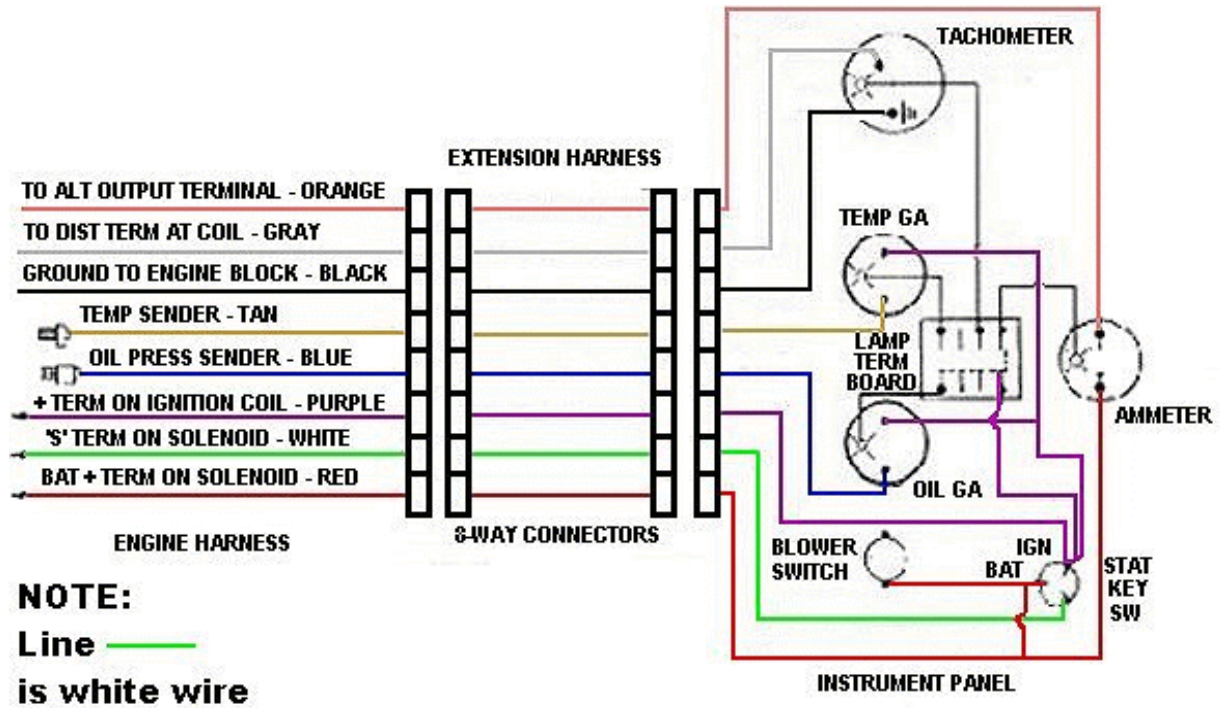

## WATER COOLING SYSTEMS

The two drain plugs and a pipe cap removed at the factory are in a small bag attached to the carburetor lever. Replace one plug in the bottom of water pump and one in the rear of the manifold near the exhaust flange. Replace the pipe cap on the drain nipple out of the cylinder block water jacket located immediately alongside the distributor.

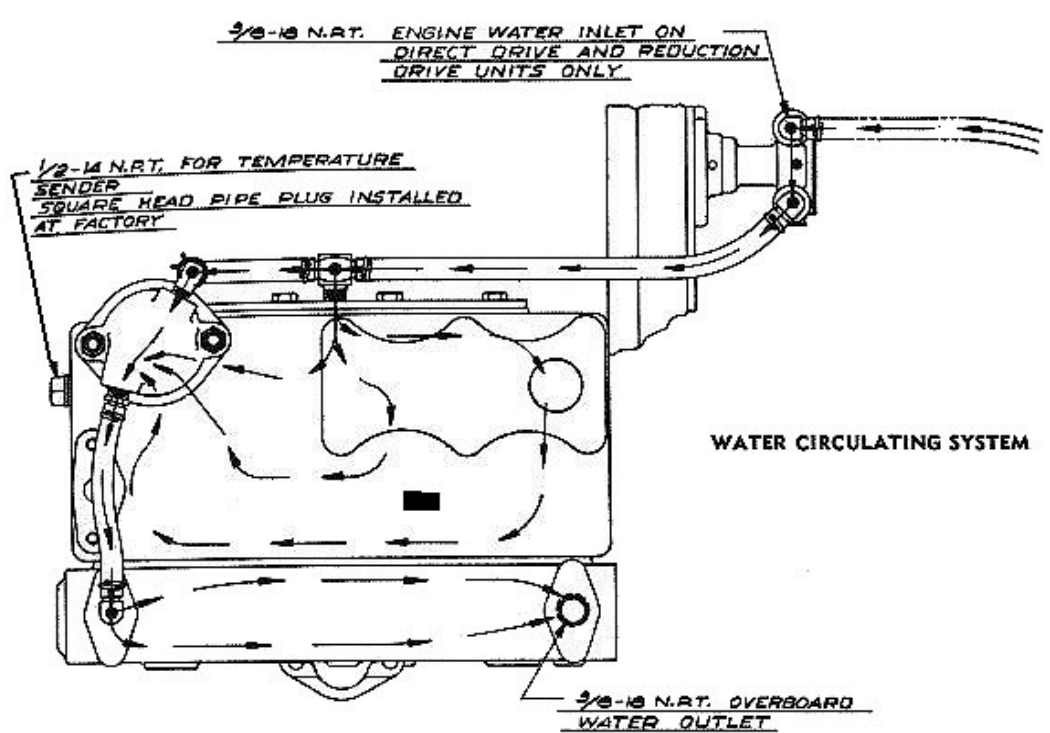

## WATER TEMPERATURE

An automatic by-pass temperature control is standard equipment on the engine. This temperature control valve is required to maintain proper engine operating temperatures. If an engine is operated too cold, condensation may form in the valve chamber causing sticky valves and other malfunctions.

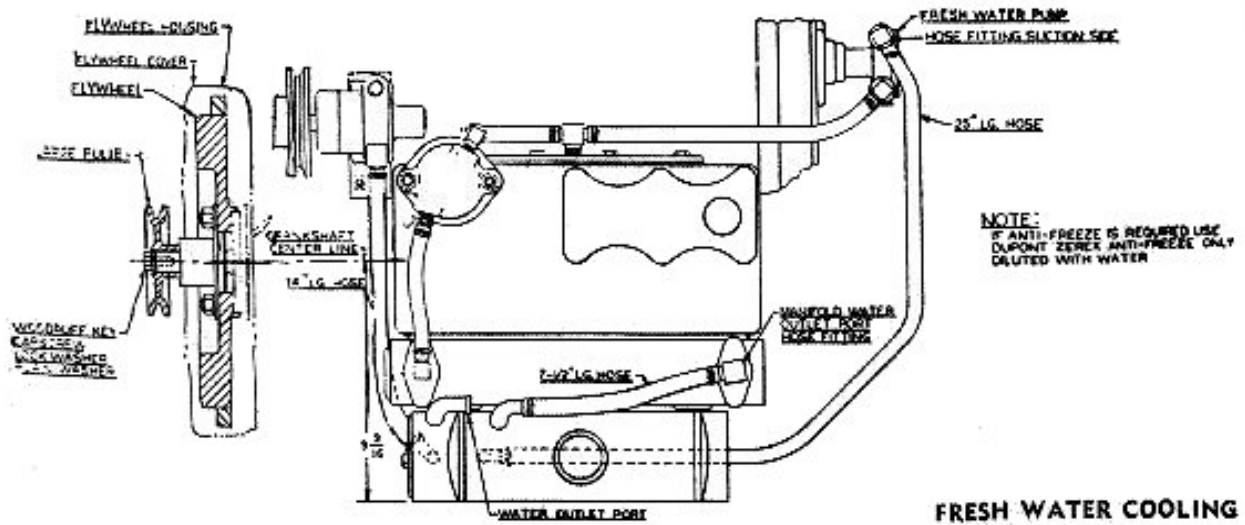

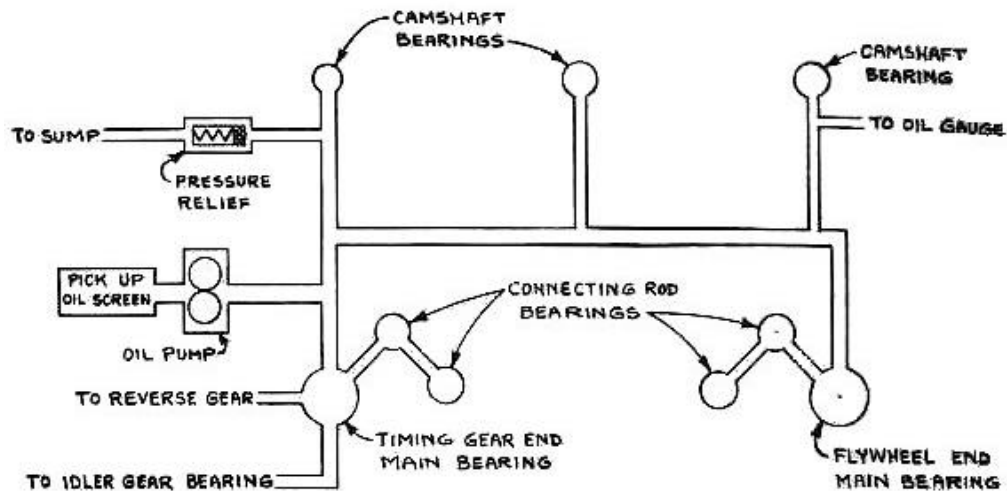

### OIL CIRCULATING DIAGRAM

The lubricating system on the ATOMIC FOUR Model is full pressure to all cam-shaft bearings, all main bearings, all connecting rod bearings, and also to the reverse gear. Fill the base with from four to five quarts of good grade SAE 30 oil or until the oil level gauge shows full, as directed on the name plate, mounted on top at the reverse gear housing. The reduction gear model will take slightly more. It is not necessary to oil the reversing gear or the reduction gear separately, as both are oiled by pressure from the main oiling system through a drilled hole in the end of the crankshaft and the tailshaft.

The oil is carried in the base, and a gear driven gear type oil pump which is submerged in the oil in the base circulates the oil through the motor under pressure.

The oil pressure regulator screw is located on the carburetor side of the motor under the fuel pump. If it is necessary to adjust the oil pressure, turning the adjusting screw to the right, or in, will increase the pressure, turning the screw to the left, or out, will decrease the pressure. The oil pressure gauge connection is also on the carburetor side and is located on the crankcase immediately behind the flywheel housing.

The oil pressure regulator screw is adjusted at the factory so that the gauge will show about 45 to 55 pounds cold for normal engine speeds, but may go as low as 10 pounds at idling speed when hot, and should not require adjusting.

**CAUTION:** We recommend that you change the oil after every forty or fifty hours of service. The oil should be drained while the motor is warm, as cold oil will not drain readily.

The hand sump pump is provided for the easy removal of old oil. The bayonet gauge indicates the proper oil level. Check oil level daily to maintain proper level.

## **VALVE CLEARANCE**

When the motor is worn, set the exhaust valves for .010 clearance and the intake valves for .008 clearance.

## **VALVE TIMING**

Timing gears are marked for proper valve timing.

## **IGNITION TIMING**

The points in the distributor should break when the piston is at top load center. If it is necessary to retune, turn the engine until compression stroke on No. 1 cylinder is reached, Then make starting Crank pin in crankshaft line up vertically with raised timing mark on the flywheel housing. Loosen tire clamp screw on the distributor arm directly beneath the distributor base. Set the rotor on line with the No. 1 spark plug and turn distributor base counter-clockwise until the points just begin to open After the distributor base has been turned so the points just begin to open and the rotor is in line with No. 1 Spark plug wire, tighten the clamp screw on the arm.

Take the boat out for a trial run end after bringing engine to normal operating temperature and the boat running at top speed. loosen the distributor clamp bolt and carefully advance the ignition timing by slowly rotating the distributor body counter-clockwise until the RPM begins to fall off. Then rotate the distributor body in the opposite direction to obtain the greatest number of RPMs without rough running of the engine. The timing is now set properly in the advanced position. The spark automatically adjusts as the engine speed changes.

## **VENTILATION**

VENTILATION OF THE MOTOR COMPARTMENT IS VERY IMPORTANT. Inlet and exhaust tunnels of adequate size must be provided to permit complete air circulation. It is recommended practice to ventilate the engine compartment each time before the engine is started.

## **SAFE PRECAUTIONS**

Keep the motor and especially the motor compartment clean and free from oily waste or cloths.

Likewise, keep gasoline and oil out of the bilge. This may be prevented by periodically inspecting the carburetor, gasoline line and connections for leaks.

Be very careful not to spill gasoline when filling your supply tank as it may drain into places where, it is not easily detected. In case your boat accidentally receives an unusually hard jolt from a collision with a dock or some other object, be sure to carefully inspect the gasoline supply tank and all gasoline lines for leaks.

**NEVER START THE MOTOR UNTIL THE MOTOR COMPARTMENT HAS BEEN VENTILATED BY EITHER OPENING THE HATCH, OR OPERATING THE BLOWER TO REMOVE FUEL FUMES.**

Have all wiring properly insulated to prevent short circuiting and **CHECK ALL WIRE TERMINALS PERIODICALLY TO BE SURE THERE ARE NO LOOSE CONNECTIONS TO CAUSE ELECTRIC SPARKS.**

### **RACING THE MOTOR**

Do not race the motor when not under load. This practice is harmful to the motor and unnecessary.

Driving the boat at high speed before the motor is “warmed up” may result in scored pistons and cylinder walls.

## Transmission Adjustment

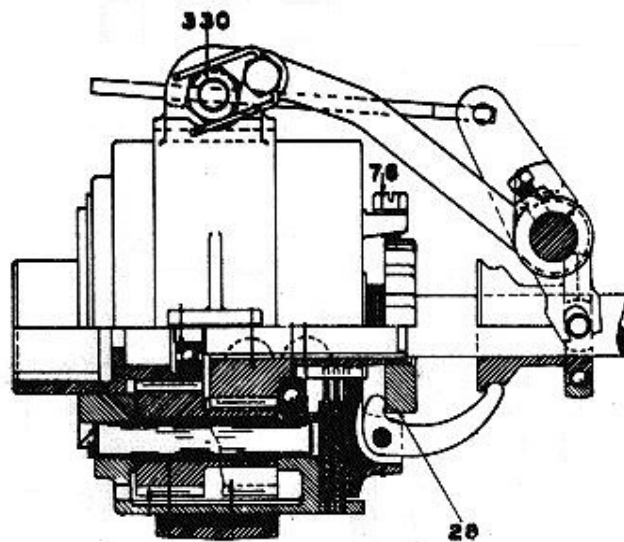

**LUBRICATION:** The reverse gear on the ATOMIC FOUR is lubricated by pressure lubrication through a drilled hole in the crankshaft and it also runs in a bath of oil.

**OPERATION :** When the reverse gear lever is pushed forward into the "Go Ahead" position, it pushes the friction cone backward, thereby spreading the fingers and causing the back of the fingers to engage the friction plungers which in turn press the discs together. This in turn acts as a solid connection between the motor and the propeller shaft.

To reverse the boat, pull the reverse gear lever backward. When the lever is pulled backward, the action clamps the broke bond to the reverse gear drum and power is then transmitted through the internal gears in the reverse direction thus reversing the propeller rotation.

### **ADJUSTMENT: FOR THE FORWARD DRIVE**

If the gear slips in the forward drive, back out the lock-screw No. 74 until the end of it is clear just of the notch in the adjusting collar No. 28 now turn collar to the right until the lock-screw No. 76 is in line with one of the notches in the adjusting collar No. 28.

Then tighten up the lock-screw No. 76 and be sure that the end of screw enters the notch in the adjusting collar No. 28. Repeat this procedure until the reverse gear holds on the forward drive. An adjustment of one or two notches is usually sufficient.

**FOR THE REVERSE DRIVE**

Pull the lever into the reverse position. Then tighten up the adjusting bolt No. 330 until the brake band clamps or grips the gear drum No. 1 and holds it from revolving. It is well to screw up this adjusting bolt No. 330 a little tighter than is necessary. This will compensate for any wear on the brake band. The lock wire holds the adjusting bolt nut and keeps it from loosening.

**FIRST:** Make sure that the shifting control actually engages and disengages the forward and reverse action of the clutch and reverse gear. Unless these contacts are properly executed avoidable wear will result involving annoyance and expense.

**SECOND:** Throw the remote control shifting lever into forward position as far as it will go. Then, disconnect the short reverse gear lever and see if it can be shifted further forward. If this can be done, the connection should be changed so as to permit the remote control shifting lever to throw the gear shift lever as far forward as possible.



## PREPARING ENGINE FOR SPRING SERVICE

Preparation of the engine should include all these items of overhaul necessary to permit satisfactory operation of the engine. Many engines properly serviced in the spring will give a full season of carefree pleasure. The amount of effort to be expended will be determined somewhat by the storage of lay-up procedure of the previous fall. Refer to preparations for starting the engine for the first time.

1. Tighten all nuts and bolts to proper torque. Replace all drain plugs and caps.
2. Manifold - Replace drain plug. Check manifold bolts for tightness since some gaskets shrink more than others.
3. Water Pump - Close drain cock and replace drain plug. Lubricate pump by grease cups. Replace packing if required. **DO NOT OPERATE PUMP WITHOUT WATER.**
4. Lubrication System - Remove all oil from oil pan and reverse gear housing. Refill with quantity specified in "Lubrication Group".
5. Cylinders - Remove spark plugs. Pour one or two ounces of oil in cylinders to lubricate walls, rings, etc., turn engine over without spark plugs in place.
6. Valves and tappets - Check and lubricate if required. Remove seal over breather tube end.
7. Distributor - Clean and lubricate as required. Remove any moisture seals. Clean and set distributor points.
8. Spark plugs - clean spark plugs and re-set gap to .035". Replace burned or broken plugs.
9. Ignition wires - Replace damaged or brittle ignition wires. High tension electrical leakage prevents good operation of engine.
10. Starting Motor - See that the starter pinion is clean and lubricated with light oil. Remove any moisture seals. Lubricate bearings. Clean commutator and brushes with sandpaper. Do not use emery cloth.
11. Alternator - Does not require any special care or lubrication.
12. Battery - Reinstall fully charged batter. Clean the cable terminals and fasten securely to clean battery terminals. Coat terminals with vaseline or grease to reduce corrosion, and then attach battery cables.
13. Fuel system - See that fuel system is clean and free from scale, sludge, or obstructions. Drain out any water that has accumulated in tanks or fuel lines. Check over for loose connections, tightening any found. Remove cover from carburetor air intake. Oil carburetor choke and throttle carburetor air intake. Oil carburetor choke and throttle shafts. Check for easy operation. Clean flame arrestor.
14. Exhaust system - remove moisture seal.
15. Turn engine over by hand with the spark plugs out to see that all bearings are free.
16. With boat in water, check freedom of propeller shaft in bearings and alignment of propeller shaft with engine.
17. Tighten stuffing box just enough to stop leakage along shaft. Excessive tightening will cause power loss and burned stuffing material.
18. Clean motor thoroughly and repaint.

## PREPARING ENGINES FOR WINTER STORAGE

Neglect in preparing an engine for winter storage may lead to annoying or costly damage which will not be seen until the engine is prepared for use the following spring. The engine should be carefully covered to give complete protection from rain and snow. Drain completely to avoid damage from freezing.

1. Fog the engine. Run the engine at about 800 RPM and using about 4 ounces of oil slowly pour it into the carburetor to coat the combustion chamber and cylinder walls. Stall the engine by pouring the last two ounces in rapidly. Also add about two tablespoons of oil in each cylinder through spark plug hole.
2. Lubrication system - The oil pan and lubrication system should be drained of old or contaminated oil so that any moisture or acid present in the oil will not cause corrosion damage during winter. Two or three quarts of new clean oil should be pumped through the system by turning the motor by hand or electric starter. This should distribute a film of clean oil to act as a rust preventive. Regular rust preventive oils can be obtained.
3. Cylinder blocks - A pipe cap is found on the distributor side of the engine. Remove and leave off.
4. Manifold - A pipe plug will be found in the right side and to the rear end of the exhaust manifold. Remove and leave out.
5. Water Pump - Pumps are particularly susceptible to damage from freezing because of the restricted space and clearances. The pump should be carefully drained by loosening the cover. The pump should be dry during the winter.
6. Electrical system - Remove the battery and store it at the boat yard or at your local battery dealer. Loosen the distributor cap for ventilation and protect all other electrical parts for moisture.
7. Fuel System - All gasoline should be drained from carburetor, fuel pump, feed lines, filters, and tanks. This is to prevent development of sludge or gum in the system. The carburetor air intake should be covered by water-proof paper or cloth and sealed to prevent entrance of moisture into engine by way of the intake valves that are open.
8. Exhaust system - Exhaust pipes should be drained free of water. Allow the exhaust pipes to dry out. Seal exhaust pipe end to prevent entrance of moisture into the engine through exhaust valves that are open.
9. Rust prevention - exposed metal parts liable to rust should be coated with grease or rust preventive compound.

## WHAT TO DO WHEN YOUR MOTOR DOES NOT OPERATE PROPERLY

The following suggestions will be of assistance in locating and remedying motor troubles. They are also mentioned to assist the operator in making emergency repairs. However, when serious trouble occurs, a competent service man should be called.

The operation of a motor depends primarily on three factors: an unfailing fuel supply; uninterrupted ignition, and good compression. Failure of either the first two will prevent starting or cause loss of power. It may also cause difficult starting or sudden stopping.

If a motor, which has previously been operating satisfactorily, refuses to start or stops with but slight warning and without the noise of a breaking part - it is reasonable to assume that either the fuel supply has been cut off or the ignition has failed. The first step should therefore be to determine which of the two systems is at fault.

**FIRST:** See that there is gasoline in the tank. Use regular gasoline.

**SECOND:** It is possible to have plenty of fuel and still be unable to fill the carburetor. This may be caused by too small a vent hole in the gasoline tank cap. The gasoline pipe may be air bound. Test the carburetor by uncoupling the pipe at the carburetor connection. If the fuel does not flow freely, the fuel line may be plugged. Blow or run a wire through the pipe to clean it. The strainer in the fuel pump or in the carburetor may also be plugged.

**THIRD:** Flooding a carburetor by over-using the choke may cause the moisture to become too rich. In this instance, remove the spark plugs and turn the engine over several revolutions.

**FOURTH:** Look for water in the fuel. If water is found, clean the fuel tank, fuel pump, fuel line and carburetor.

**FIFTH:** Check for an air leak in the intake manifold. This can be easily tested by squirting oil around the intake connections.

If the fuel system is O.K. check as follows for ignition troubles.

**FIRST:** Be sure the ignition switch is turned to the "ON" position.

**SECOND:** Look for a fouled or broken spark plug.

- THIRD:** Check for weak spark. If a bright spark jumps across the gap between the two points of the plug when the engine is turned over, the ignition system is undoubtedly in working order. This may be verified by making the same test with each wire. The gap between the spark plug points should be approximately .035" (or the thickness of a thin dime).
- FOURTH:** Check for a broken electrical circuit.
- FIFTH:** The cause may be due to a ground. Poor installation will cause a ground. Be sure all electrical wires are clean and well insulated.
- SIXTH:** Poor contact at distributor breaker points.
- SEVENTH:** Distributor may be out of time.

## TROUBLE SHOOTING

A gasoline engine depends upon three main factors for proper operation; an unfailling fuel supply, uninterrupted ignition, and good compression. When any one of these are not present, or present only intermittently, engine failure will result. The following "trouble shooting" information is designed to help the operator locate and overcome some of the most probable causes of engine failure, or improper operation. "Probable Causes" are listed in the most likely order of occurrence. Only one correction should be attempted at a time and that possibility eliminated before going on to the next.

### TROUBLE SHOOTING PROCEDURES

TROUBLE	PROBABLE CAUSE	CORRECTION
Starter will not crank engine	Discharged Battery	Charge or replace battery
	Corroded battery terminals	Clean Terminals
	Loose connection in starting circuit	Check and tighten all connections
	Defective starting switch	Replace switch
	Starter motor brushed dirty	Clean or replace brushes
	Jammed Bendix gear	Loosen starter motor to free gear
Starter motor turns but does not crank engine	Defective Starter Motor	Replace Motor
	Partially discharged battery	Charge or replace battery
	Defective wiring or wiring of too low capacity.	Check wiring for worn acid spots.
Engine will not start	Broken Bendix Drive	Remove starter motor and repair drive
	Empty fuel tank	Fill tank with proper fuel
	Flooded Engine	Remove spark plugs and crank engine several times. Replace plugs
	Water in fuel system	If water is found, clean tank, fuel lines, and carburetor. Refill with proper fuel.
	In-operative or sticking choke valve	Check valve, linkage, and choke rod or cable for proper operation
	Improperly adjusted carburetor	Adjust carburetor

	Clogged fuel lines or defective fuel pump.	Disconnect fuel line at carburetor. If fuel does not flow freely when engine is cranked clean fuel line and sediment bowl. If fuel still does not flow freely after cleaning, repair or replace pump.
Engine will not start. (Poor compression and other causes)	Air leak around intake manifold	Check for leak by squirting oil around intake connections. If leak is found, tighten manifold and if necessary replace gaskets.
	Loose Spark Plugs	Check all plugs for proper seating, gasket and tightness. Replace all damaged plugs and gaskets.
	Loosely seating valves	Check for broken or weak valve springs, warped stems, carbon and gum deposits, and insufficient tappet clearance
	Damaged cylinder head Gasket	Check for leaks around gasket when engine is cranked. If a leak is found replace gasket.
	Worn or broken piston rings	Replace broken and worn rings. Check cylinders for "out of round" and taper.
Excessive engine temperature	No water circulation temperature	Check for clogged water lines and Restricted inlets and outlets. Check for broken or stuck thermostat. Look for worn or damaged water pump or water pump drive.
Engine temperature too low	Broken or stuck thermostat	Replace thermostat
Engine will not start. (Ignition System)	Ignition switch "off" or defective	Turn on switch or replace
	Fouled or broken spark plugs	Remove plugs and inspect for cracked porcelain, dirty points, or improper gap.

	Improperly set, worn or pitted distributor points. Defective ignition coil.	Remove center wire from distributor cap and hold within 3/8" of motor block. Crank engine. Clean sharp spark should jump between wire and block when points open. Clean and adjust points. If spark is weak or yellow after adjustment at points, replace condenser. If spark still is weak or not present, replace ignition coil.
	Wet, cracked, or broken distributor	Wipe inside surfaces of distributor. Dry with clean cloth. Inspect for cracked or broken parts. Replace parts where necessary.
	Improperly set, worn, or pitted magneto breaker points. (Magneto models only)	Remove spark plug wire and hold within 3/8" of engine block. Clean sharp spark should jump between wire and block when engine is cranked. If spark is weak or not present clean and adjust breaker points
	Improperly set, worn, or pitted timer points. Defective coil or compression and defective condenser.	Remove spark plug wire and hold within 3/8" of engine block. A clean sharp spark should jump between wire and block when engine is cranked. Clean and set timer points. If spark still is not present when engine is cranked, replace coil.
No Oil Pressure	Improper timing	Adjust timing.
	Defective gauge or tube	Replace gauge or tube.
	No oil in engine	Refill with proper grade oil.
	Dirt in pressure relief valve	Clean valve
	Defective oil pump, leak in oil lines or broken oil pump, oil lines or oil pump drive.	Check oil pump and oil pump drive for worn or broken connections.
Loss of RPM (Boat or associated equipment)	Damaged propeller	Repair propeller
	Bent rudder	Repair
	Misalignment	Realign engine to shaft
	Too tight stuffing box packing gland	Adjust
	Dirty boat bottom	Clean bottom

Vibration	<p>Mis-firing or pre-ignition</p> <p>Loose foundation or foundation bolts</p> <p>Propeller shaft out of line or bent</p> <p>Propeller bent or pitch out of true</p>	See correction under mis-firing and pre-ignition
Pre-Ignition	<p>Defective spark plugs</p> <p>Improper timing</p> <p>Engine carbons</p> <p>Engine overheating</p>	<p>Check all spark plugs for broken porcelain, burned electrodes or electrodes out of adjustment. Replace all defective plugs or clean and reset. See instructions for re-timing</p> <p>Remove cylinder head and clean out carbon.</p> <p>See correction under "Engine Temp" portion of this table.</p>
Back-Firing	<p>Insufficient fuel reaching engine due to dirty lines, strainer or blacked fuel tank vent. Water in fuel.</p> <p>Poorly adjusted distributor.</p>	<p>See correction under "Engine will not start" portion of this table.</p> <p>See correction under "Engine will not start" portion of this table.</p>
Low Oil Pressure	<p>Too light body oil</p> <p>Oil leak in pressure line</p> <p>Weak or broken pressure relief valve spring.</p> <p>Worn oil pump</p> <p>Worn or loose bearings</p>	<p>Replace with proper weight oil. Inspect all oil lines. Tighten all connections.</p> <p>Replace spring</p>
Oil Pressure too high	<p>Too heavy body oil</p> <p>Stuck pressure relief valve</p> <p>Dirt or obstruction in lines</p>	<p>Replace pump</p> <p>Replace bearings</p> <p>Drain oil and replace with oil of proper weight.</p> <p>Clean or replace valve</p> <p>Drain and clean oil system. Check for bent or flattened oil lines and replace where necessary.</p>
Sludge in oil	<p>Infrequent oil changes</p> <p>Water in oil</p> <p>Dirty oil filter</p>	<p>Drain and refill with proper weight oil</p> <p>Drain and refill. If trouble persists, check for cracked block, defective head gasket and cracked head.</p> <p>Replace filter (if one is mounted on engine)</p>



## **A FINAL WORD**

Universal's interest in both customer and product continues long after the engine is installed. Within the limits of our specifications, the company's service department is ready to serve your maintenance and repair needs quickly. In addition, all Universal factory personnel will promptly answer inquiries regarding maintenance, installation or special adaptations.

If you will use judgment and care in operating your Universal engine, use sufficient quantities of the recommended lubricants, stay on the alert for the first signs of trouble, and contact Universal whenever you need aid, the life and usefulness of your Universal power package will be greatly increased.

# **SERVICE AND REPAIR MANUAL FOR**

## **ATOMIC 4**

### **MARINE ENGINE**

## GENERAL INFORMATION

### INTRODUCTION

This manual provides service information and repair procedures for your Atomic 4 marine engine. How well your engine will continue to deliver the performance originally built into it depends on the service and care it receives. The information provided is adequate for performing all maintenance required and carrying out repairs to the level of a minor overhaul. Detailed disassembly, repair and assembly procedures are provided in step-by-step format. Where repair is impractical for the amateur mechanic, this is indicated. A dealer or other repair shop should carry out complex repairs. For boat owners who are installing an Atomic 4 engine to replace an existing engine of another make, this manual provides information on major installation considerations such as engine dimensions, exhaust systems, and alignment.

### MANUAL ORGANIZATION

The manual is divided into nine sections

**GENERAL INFORMATION** provides general specifications, a description of the engine and components, safety considerations, preparation of new engines, engine break-in and operation, significant engine changes, engine serial number locations and spare/repair parts sources.

**MAINTENANCE AND LUBRICATION** details the procedures to keep your engine at peak operating efficiency, and procedures for spring commissioning and winter lay-up.

**ELECTRICAL SYSTEM** gives information on the operation, maintenance and repair of the electrical system components and wire sizes for auxiliary equipment.

**FUEL SYSTEM** deals with the fuel supply system, including electrical and mechanical fuel pumps.

**COOLING SYSTEM** provides data on the operation and maintenance of the cooling system.

**ENGINE** contains information necessary to carry out a minor overhaul and replace the main engine components such as piston rings, valves and bearings.

**TRANSMISSION AND REDUCTION GEAR DRIVES** gives information on adjustment and maintenance of these components.

**SUPPLEMENTARY INFORMATION** provides information for diagnosing engine trouble, exhaust systems, engine alignment, propeller selection, shaft stuffing box, re-fueling, recommended spare parts and tools.

**SPECIFICATIONS** lists all engine dimensions, wear limits, torque values and adjustments.

**WARNINGS, CAUTIONS AND NOTES** are used throughout to emphasize important instructions. These inserts generally precede the applicable text or instruction and do not contain procedural steps. Warnings, cautions and notes are used to highlight information, as follows:

**WARNING**

**An operating procedure, practice, etc., which, if not correctly followed, could result in personal injury.**

**CAUTION**

**An operating procedure, practice, etc., which if not strictly observed, could result in damage to components.**

**NOTE**

**An operating procedure or condition which is essential to emphasize.**

## **DESCRIPTION OF ENGINE**

The Atomic4 is an inline four cylinder, four-cycle engine of conventional design and robust construction.

These engines have side valves mounted in replaceable guides. Valves operate off a gear-driven camshaft by solid lifters (tappets).

The cylinder block is cast iron with cast cylinder walls for maximum strength. The cylinders have a full length water-jacket to minimize hot spots. The cast walls permit more uniform heat absorption and dissipation which allows equal expansion and contraction sufficient for heavy-duty operation and less frequent overhauls.

A water-jacketed cast-iron manifold contains the air intake and exhaust passages.

Pistons are aluminum alloys with two compression rings and one oil control ring above the piston pin.

The forged alloy crankshaft runs in two large diameter aluminum-tin bearings.

The engine is pressure lubricated by a gear-type oil pump driven directly off the crankshaft. An oil pressure adjustment is provided in the cylinder block.

The fuel system includes an electric fuel pump (mechanical fuel pump on engines before serial No. 202987) delivering fuel to an updraft, single-venturi carburetor with a manual choke. A removable flame arrester is fitted at the carburetor throat.

The water pump is driven off the accessory drive and circulates cooling water through the engine and exhaust system. A special three-spring thermostat located in the cylinder head controls engine operating temperature while permitting a constant supply of water to the exhaust system.

The electrical system is an alternator-based 12-volt negative-ground system. Main components are an alternator with solid-state regulator, starter, distributor and ignition coil.

All engines are equipped with transmissions providing forward as well as reverse drive. Three final-drive arrangements are available: direct-drive; 2:1 reduction drive; or V-drive with reduction.

Engines are factory-tested on a dynamometer under load conditions. After testing, each engine is fogged and drained of oil and water prior to shipment.

## **SAFETY CONSIDERATIONS**

Operation of power driven vessels requires attention to safety procedures and potentially dangerous conditions. Some of the major conditions that operators should be aware of are listed below:

### **Fumes and Vapours**

Gasoline vapours are heavier than air and can collect in the bilge, therefore, the vessel should be closed up when refueling to prevent vapours from entering the cabin. Also, the condition of the fuel system should be checked as often as possible to detect any gasoline leakage which must be corrected before the engine is started. An approved (non-sparking) bilge blower should be installed and operated before attempting to start the engine. Do not operate the engine with the flame-arrester removed from the carburetor intake.

### **Open Flames**

During periods of charging, lead-acid batteries give off hydrogen gas which combines with air to form a potentially explosive atmosphere. Open flames or sparks should be kept away from batteries at all times.

### **Exhaust System Leaks**

One of the main products of combustion from gasoline engines is carbon monoxide, a colourless, odourless gas which is harmful if inhaled. Care should be taken to ensure that the engine exhaust system is gas-tight to prevent the build-up of carbon monoxide gas in the cabin. Passengers should not be permitted to sleep below when the engine is operating.

### **Cleanliness**

The engine and engine compartment should be kept clean and free from oil or oil-saturated rags. When carrying out routine maintenance and inspection, check for leaks and correct them immediately. Dispose of dirty cloths after use.

### **Moving Parts**

In some instances it may be necessary to carry out some maintenance or repair operation while the engine is running. Take special care to avoid the exterior rotating elements such as the alternator drive-belt and pulleys and shaft coupling.

## **Electrical Shocks**

Electrical shocks can occur from the charging or ignition systems if electrical components are shorted out when the engine is operating. Be careful not to ground the positive terminal of the battery.

## **PREPARATIONS FOR STARTING ENGINE (See Fig. 1 and 2)**

All engines are factory tested for at least three hours prior to delivery. After testing engines are drained of water and oil and fogged with a rust-inhibiting oil. Before starting new engines the following should be done.:

### **Lubricating Oil**

Add 3 to 5 quarts of SAE30 or 10W30 detergent oil, depending on the engine model and angle of installation of the boat. Reduction-gear units and transmissions are supplied with oil from the engine supply. For engines equipped with V-drive units, special oil must be added separately.

FIGURE 1.

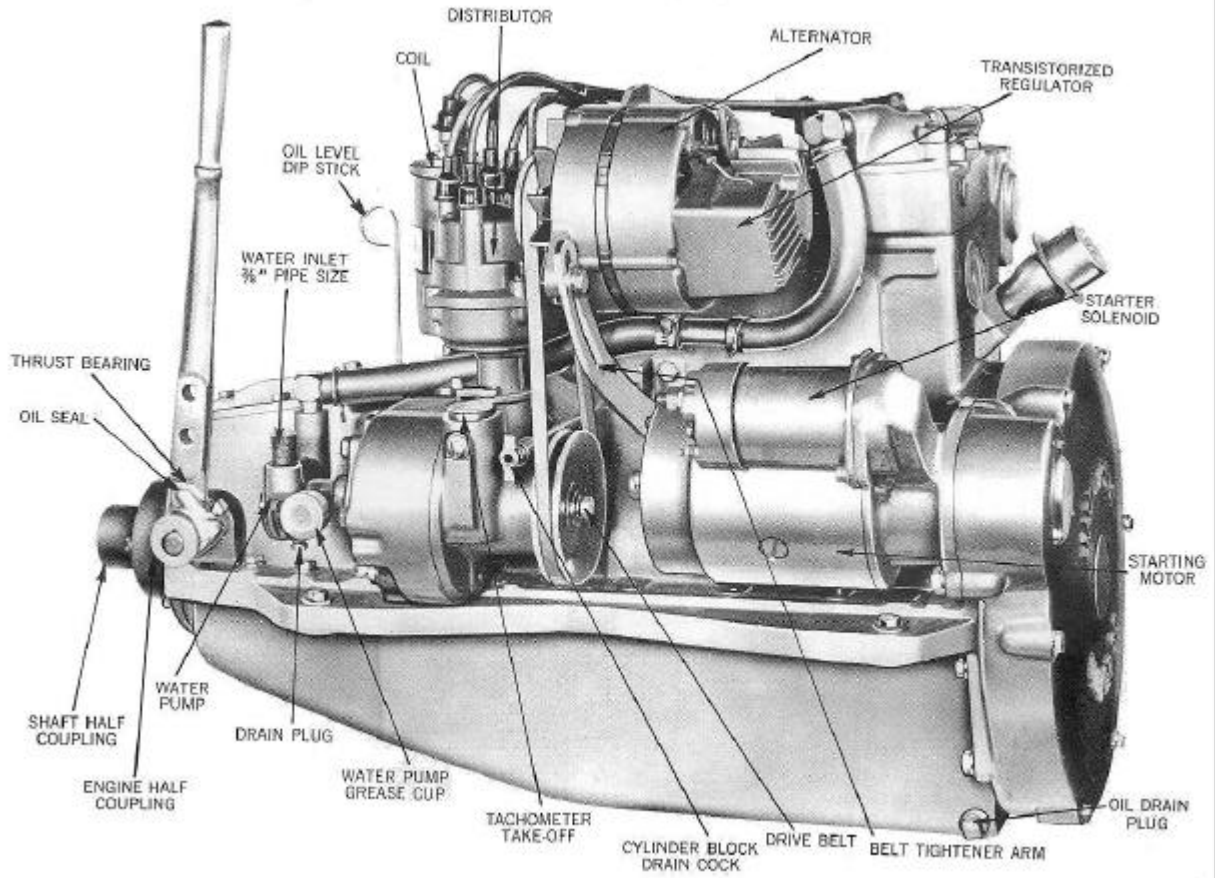
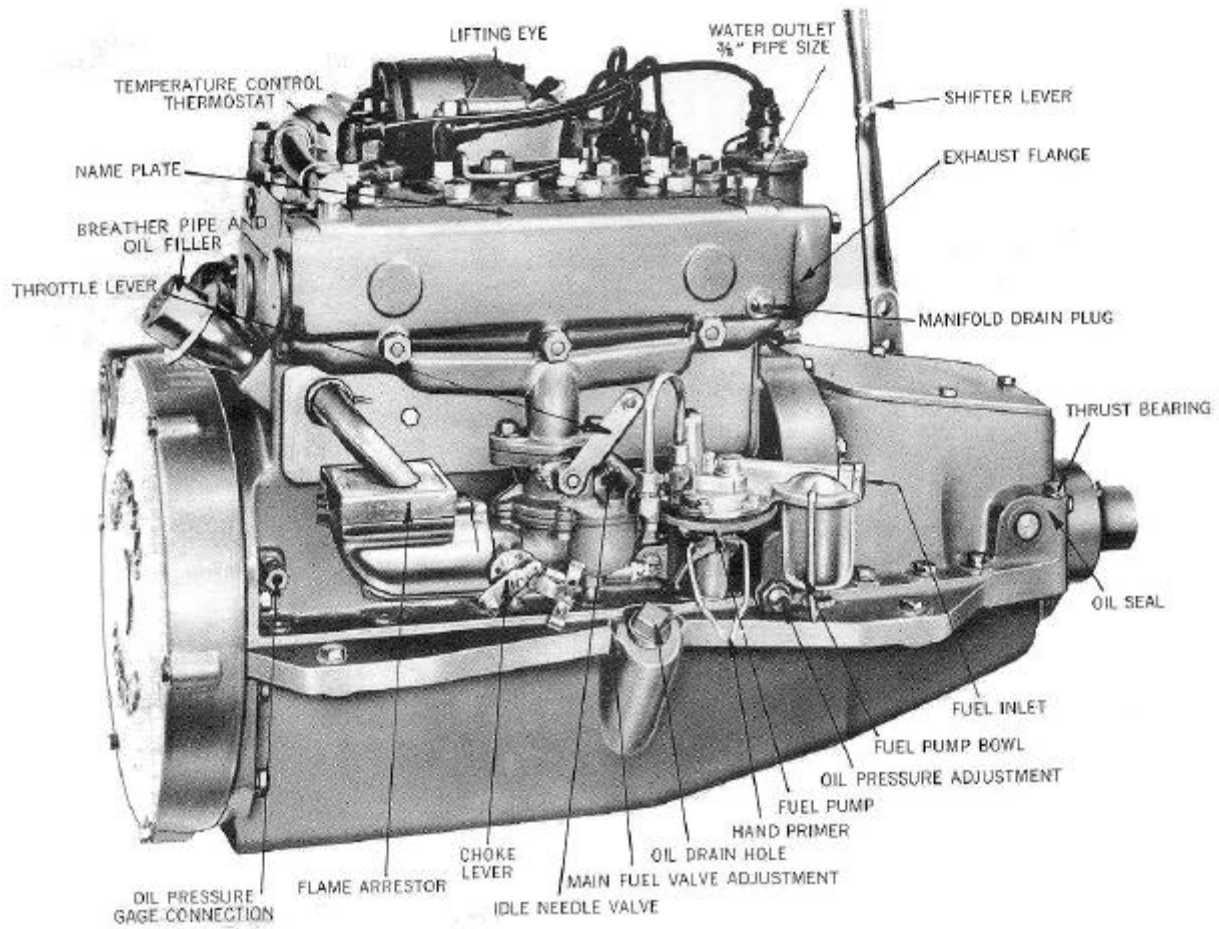



FIGURE 2



## Engine Drain Plugs

Check that all drain plugs are installed; two on the engine block and one each on the manifold and water pump.

## Cooling Water Supply

A continuous water supply is required for engine and exhaust system cooling. A sea-cock should be installed at the through-hull water fitting. The water pump suction and discharge connections are 3/8 inch diameter as is the water discharge connection at the rear of the manifold. Water pump suction hose should be suitable for full vacuum service (i.e. non-collapsible).

### CAUTION

**Do not run the engine without a water supply or the water pump impeller will be permanently damaged.**

Make sure that the sea-cock is open and the water pump shaft is lubricated (see Figure 3).

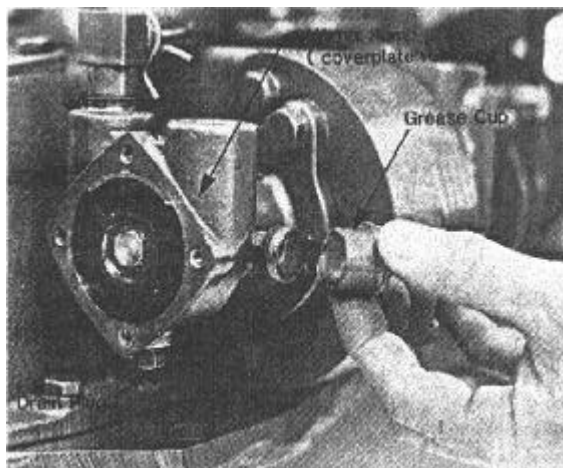

**Figure 3**

## Choke and Throttle Linkage

Remove the flame arrester and check that the choke 'butterfly' valve in the carburetor throat fully opens and closes when the choke control is operated (see Figure 4). Replace the flame arrester before attempting to start the engine. Operate the throttle control to make sure that there is free movement from idle to full throttle positions.

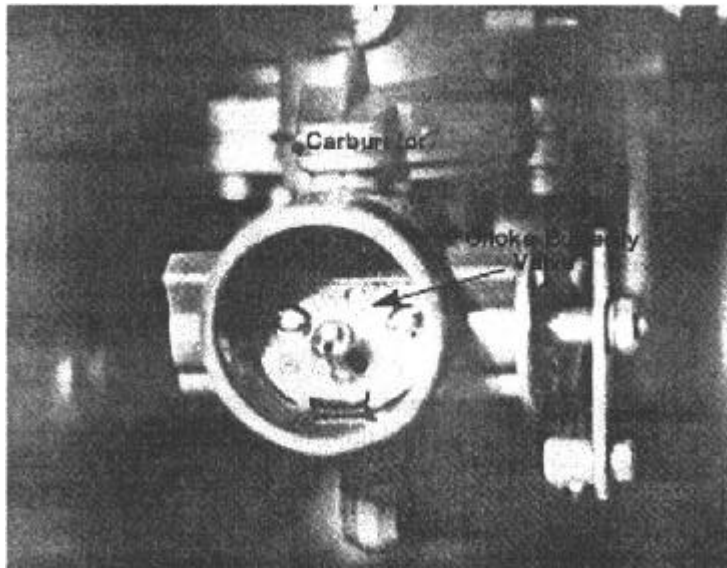

**FIGURE 4 - ADJUSTING CHOKE BUTTERFLY VALVE**

## STARTING ENGINE

Before attempting to start your engine, the following preliminary checks should be carried out:

1. Ventilate the engine compartment by turning on blower fan and opening hatches, Run the blower fan for at least five minutes.
2. Open fuel shut-off valve. Check fuel system for leaks.
3. Turn on battery isolator switch.
4. Open sea-cock to provide cooling water to water pump.
5. Check oil level in engine and V-drive unit. oil level should be between marks on dipsticks.
6. Lubricate water pump seats by turning grease cup cover in 3/4 turn.
7. Pull out choke control.
8. Set throttle at 1/4 open position.
9. If equipped with exhaust shut-off valve, open valve.

### CAUTION

**Do not operate the starter for more than 15-20 seconds; cooling water enters lift-type mufflers during cranking and may back up into the engine when cranking is stopped if muffler overfills.**

10. Turn on ignition switch and start engine.
11. When engine starts, slowly push choke control all the way in.
12. Adjust throttle for idling speed of 600-1000 rpm (fast idle).
13. Check oil-pressure gauge reading; oil pressure should be 35-45 psi for cold engine.

14. Check for discharge of cooling water at exhaust fitting; temperature gauge reading should gradually rise to 140-160 degrees F.
15. Allow engine to run for ten minutes if gauge readings are satisfactory.
16. Stop engine and check oil level. Add oil if required to bring level within marks on dipstick(s). Do not overfill as this can cause oil leaks.

### **ENGINE RUNNING~IN PERIOD**

For new engines, some care should be taken for the first 10 hours of operation in order to properly break in components such as bearings, piston rings and valves.

Operate your engine at approximately three-quarters (1500 rpm) of normal cruising speed to ensure proper running in of the engine. Do not allow the engine to idle for extended lengths of time during the break-in period.

After this initial 10-hour operating period, change the engine oil (refer to Chapter 2 - Maintenance). A suitable cruising speed for most installations is about 2000 rpm (80% of maximum engine speed obtainable).

### **ENGINE OPERATION**

1. When shifting into forward or reverse, engine speed should be 600-1000 rpm (fast idle).
2. Do not open the battery circuit or change batteries when the engine is running, as this can cause alternator or regulator damage.
3. Periodically check engine gauges for proper readings. Readings should be within the following ranges:

Oil pressure	(engine cold)	35-45 psi
	(engine warm)	10-25 psi at idle
		25-35 psi at 2400 rpm
Water temperature		140-160 degrees F
Ammeter		0- +50 amps

## SIGNIFICANT ENGINE CHARACTERISTICS

The manufacturer incorporates design improvements periodically to reflect the best current practices for marine engines. Some modifications are minor while others have been major. Listed below are the significant changes made to date:

Up to Serial No.79475	- all parts interchangeable - Dole thermostat (on manifold) - Prestolite ignition
Serial No.79476 through No.170508	- new style engine; not interchangeable with above- - Holley thermostat (in head) - Delco Remy ignition - Zenith Series 61 carburetor
Serial No.170509 and later	- Motorola alternator (interchangeable) - Zenith Series 68 carburetor
Serial No.171514 and later	- valve chamber oil line deleted
Serial No.174340 and later	- Oberdorfer water pump (interchangeable)
Serial No.174802 and later	- new style valves
Serial No.176500 and later	- revised valve guide tolerances .3150"- .3145"
Serial No.192787 and later	- new style flywheel and cover
Serial No.202987	- electric fuel pump and low oil pressure switch

## ENGINE SERIAL NUMBER LOCATIONS

An engine identification plate is located on the flywheel cover or on the manifold. In addition, the engine number is cast into the engine block on the right side below the carburetor and on the transmission housing.

## SPARE AND REPAIR PARTS

When ordering parts from your dealer always order by engine model and serial number since changes are made to engines from time to time. If possible, compare new parts to old before purchasing them. If they are not identical, have the dealer explain the difference.

A special on-board spare parts kit is available. The kit contains parts required for emergency needs such as contact points, spark plugs, water pump impeller and alternator drive belt. You can obtain the on-board spare parts kit from your Atomic4 dealer. Dealers are located throughout Canada and the United States. They have an ample inventory of parts and can provide prompt, expert service for the maintenance and repair of your engine.

**GENERAL SPECIFICATIONS**

Engine type	In-line, 4-cylinder, L-head
Bore	2.562 inches
Stroke	3.125 inches
Displacement	64.5 cubic inches
Compression Ratio	6.3:1
Brake Horsepower	30@3500 rpm
Engine Rotation	Counter-clockwise viewed from flywheel end of engine
Final Drive	Ratio Direct-drive 1 to 1 Reduction-drive 2 to 1 V-drive 1.29 to 1, 1.67 to 1 or, 2 to 1
Fuel	Reg. grade gasoline (90-94 Octane)
Lubricating Oil Engine:	SAE30 or 10W30 V-drive: 90 gear oil
Spark Plugs	Champion US 14 mm
Firing Order	1-2-4-3
Weight (dry)	Model 5101 - 310 lbs. 5102 - 330 lbs. 5103 - 335 lbs.
Overall length	Model 5102 - 32-1/8 inches 5103 - 36 inches
Overall height	All models 19-5/16 inches
Overall width	All models 18-3/16 inches
Maximum Operating Angle (fore to aft)	15 degrees
Compression Pressure	90-125 psi (all spark plugs removed and throttle open)

## MAINTENANCE

### GENERAL

To ensure good performance, dependability and safety, regular maintenance of your engine is necessary. This chapter outlines routine checks and periodic maintenance required under normal service. Engines operating for extended periods or in severe service may require more frequent inspections and maintenance. Regular attention to maintenance requirements will help avoid unnecessary repairs.

A systematic engine tune-up procedure is provided at the end of this chapter

### ROUTINE CHECKS

The following checks should be performed at least every two weeks:

1. Engine oil. Oil level should be checked with the engine warm and should be between the two marks on the dipstick, never below or above. Add oil if necessary. Oil level will vary from engine to engine based on the angle of installation. Water in the crankcase will cause the oil to turn a gray or milky colour. If your engine is equipped with V-drive, also check oil level.
2. Alternator drive belt (see Figure 5). Examine for fraying and proper tension. A spare belt should be carried aboard.
3. Water pump (see Figure 6). Check grease cup for adequate amount of grease. If the grease cup is turned in as Off as it will go, it should be refilled. Use a good grade of water pump grease.
4. Fuel, oil or water leaks. daily check the engine and oil and water lines for leaks. Fuel leaks must be corrected before attempting to start the engine.
5. High-tension wires and electrical connections. Check for cracked insulation, loose or corroded connections or wires which may have been accidentally damaged.
6. Shaft coupling bolts. Inspect the bolts fastening the engine shaft couplings. These bolts should be tight at all times.

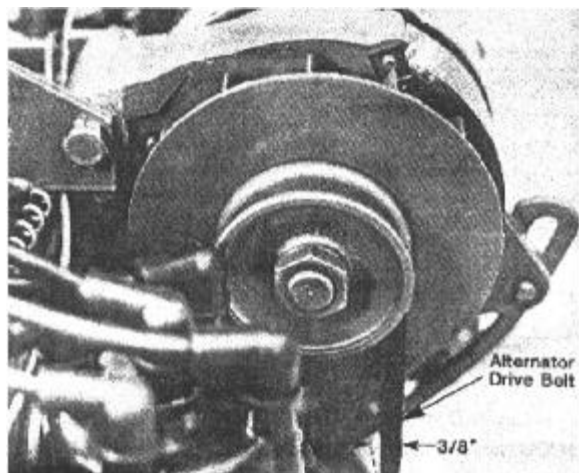
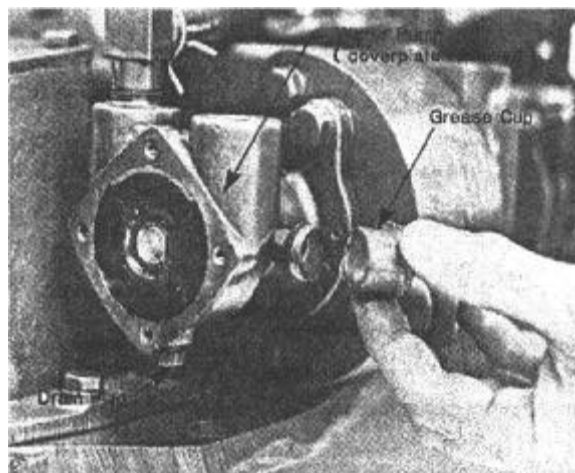
**Figure 5****Figure 6**

7. Water intake sea-cock. If equipped, check that the sea-cock operates freely and that the valve can be easily closed if required

A general inspection of the engine accessories should be made. In particular, check the condition of the following:

1. battery cables and terminals
2. exhaust system connections
3. throttle and choke controls and linkage
4. shift lever and linkage
5. propeller shaft stuffing box
6. engine mounting bolts
7. flexible connections

## PERIODIC MAINTENANCE

### Changing Engine Oil

The oil change interval will vary depending on the type of use the engine gets. If operation is primarily for short periods of time, change the oil more frequently. As a general rule, under normal use the oil should be changed every two months and before winter lay-up. Detergent type oil should be used.



**To change oil:**

- 1.. Warm engine to operating temperature.
2. Remove dipstick and insert engine sump pump tube.
3. Transfer oil to disposal container.
4. Replace dipstick
5. Refill engine until dipstick shows full (3 to 5 U.S. quarts or 3 to 5 litres depending on engine model and angle of installation).
6. Check oil level after rerunning engine. Top up oil if required. Do not overfill as this can cause oil leaks.

**Servicing Water Pump (see Figure 6)**

Lubrication of the water pump seals is provided from the grease cup located on the pump body. Periodically tighten the cup until some resistance is felt to force the grease into the drive shaft housing. When the grease cup cannot be turned further in, refill with a good grade of water pump grease.

Instructions for dismantling and repairing the water pump are contained in Chapter 4.

**Carburetor Flame Arrester**

The flame arrester fitted at the carburetor throat should be removed and cleaned occasionally to permit an unrestricted air supply to the carburetor.

The flame arrester is easily removed by loosening the clamp screw and pulling the unit off the carburetor throat. Clean by soaking in mineral spirits and allow to dry. If available, use compressed air to assist cleaning.

**Ignition System**

The ignition system is comprised of a high-voltage coil, condenser, breaker points, distributor, spark plugs and interconnecting wiring, all of which must function properly on a continuous basis to provide a strong spark at the spark plugs.

The condition of the high-tension coil and condenser can only be tested using electrical testing equipment. For this reason, it is wise to carry a spare condenser and coil on board.

Note that if the ignition key has been left 'ON' for an extended period, without the engine running, the coil can be burned out.

Periodic maintenance of the ignition system includes:

- cleaning and re-gapping or replacement of spark plugs
- visual inspection of breaker points for condition and replacement if necessary
- visual check of high-tension wires for condition resetting of ignition timing

### **Spark Plug Cleaning/Replacement**

Spark plugs should be examined and cleaned or replaced at least once a year.

1. Remove spark plugs and examine for condition. If electrodes are badly worn or porcelain insulator is damaged, replace the spark plugs.
2. Clean electrodes with a stiff wire brush and re-gap to 0.35" using a feeler gauge (see Figure 8).
3. Replace plugs and tighten with fingers. Torque plug, to 30 ft. lbs. (approx. 1-1/4 turn) using a spark plug socket wrench.

### **ENGINE TUNE-UP**

To ensure trouble-free operation, an engine tune-up should be carried out at least once per season, preferably in the spring for boats which have been laid up through the winter. The following tasks comprise a minor tune-up adequate to produce proper performance from your engine.

1. Clean and re-gap spark plugs. Replace if badly worn
2. Change engine oil (if not done before winter lay-up)
- 3.. Replace ignition points and condenser (refer to Chapter 3).
4. Examine and adjust alternator drive-belt. Replace if frayed (refer to Chapter 3).
5. Examine ignition high-tension wiring. Replace if cracked or brittle.
6. Clean fuel pump sediment bowl if mechanical fuel pump fitted (see Chapter 4).
7. Replace or clean fuel filter, if fitted.
8. Check choke and carburetor mixture settings; adjust throttle for proper engine idle speed (refer to Chapter 4).
9. Check water pump lubrication cup and add grease if required.

A major tune-up comprises all the foregoing and the following additional steps.

10. Carburetor overhaul (refer to Chapter 4).

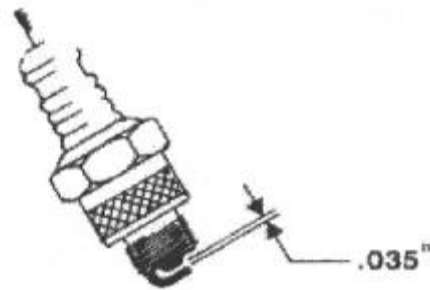

**FIGURE 8 - SPARK PLUG GAPPING**

11. Adjust valve tappet clearances (refer to Chapter 6).
12. Reset ignition timing (refer to Chapter 3).

### **PREPARATIONS FOR SPRING SERVICE**

Proper preparation of your engine in the spring will contribute to a full season of reliable operation.

If the crankcase oil was changed the previous fall before lay-up it is not necessary to change the oil again. In preparation for operation, carry out the following steps:

1. Replace three drain plugs (see Figures 1 and 2).
2. Adjust alternator drive-belt for correct tension (see Figure 5).
3. Tighten water pump cover and lubricate pump by turning grease cup in, one to one and a half turns.

### **CAUTION**

**Do not operate engine until a water supply is available to the water pump.**

4. Remove spark plugs and pour about two tablespoons of oil into each cylinder; turn engine over by hand (with ignition off) to coat cylinder walls with oil; clean and re-gap plugs to .035", replace plugs and tighten to 30 ft. lbs. (finger tight plus 1/4 turn).
5. Remove distributor cap and clean cap and distributor; clean and reset breaker points (refer to Chapter 3); replace if badly pitted or worn; replace distributor cap.
6. Examine high-tension wires to coil and spark plugs for damage or brittleness; replace if required.
7. Check hose connections for tightness, including V-drive cooler hoses.
8. Reconnect propeller shaft if disconnected.
9. Install fully charged battery; remove cover from exhaust outlet; turn on fuel supply to engine and check for leaks; open water pump sea-cock.

## PREPARATIONS FOR WINTER STORAGE

In areas where boats are hauled for storage over the winter, proper preparations will avoid damage and assure trouble-free start-up next season. Before the boat is hauled, change the crankcase oil. This is best done afloat since the engine should be at operating temperature before draining the oil. Refill the crankcase with the required amount of fresh oil and run the engine for a few minutes to distribute the oil. By changing the oil prior to storage, residual acids and moisture are removed and the engine is better protected against internal corrosion during the lay-up period.

After haul-out carry out the following steps:

1. Remove the three drain plugs located as shown in Figures 1 and 2.
2. Loosen the cover on the water pump to drain the remaining water from the pump.
3. Drain the exhaust system.
4. Remove the spark plugs and add about two tablespoons of fresh engine oil to each cylinder; turn the engine over by hand (with ignition off) to coat cylinder walls with oil; replace spark plugs finger-tight.
5. Loosen the two alternator mounting bolts and release the tension from the drive belt (see Figure 5).
6. Shut off fuel supply.
7. Top up the fuel tank to minimize condensation.
8. Cover the carburetor intake and exhaust system outlet to prevent moisture from entering the engine by way of open valves.
9. Drain water from the V-drive cooler by removing the inlet hose; replace hose after draining.
10. Remove batteries and store to prevent freezing.
11. Loosen the distributor cap for ventilation.
12. Coat exposed metal parts with grease or rust inhibitor.
13. Cover the engine to provide protection.
14. For wooden vessels it is advisable to disconnect the propeller shaft from the engine to allow for hull movement during storage.

## ELECTRICAL SYSTEM

This chapter includes descriptions and service procedures for the ignition, starting and charging circuits of your engine. Also included is information on battery testing and maintenance, location of fuses and engine wiring diagrams.

### IGNITION SYSTEM

The ignition system consists of the battery, ignition switch, ignition coil, distributor, spark plug and associated wiring.

#### Theory of Operation

Two separate circuits, the primary (low-tension) and the secondary (high-tension) comprise the ignition system. The low tension circuit includes the battery, distributor points, low voltage ignition coil winding and the condenser. The high tension circuit includes the distributor rotor and cap, high voltage winding of the ignition coil, the high-tension wires and the spark plugs.

When the ignition is on, current from the battery flows to the low-voltage winding of the coil through the contact points in the distributor. Alternate opening and closing of the contact points causes the current flow to stop and start, producing a fluctuating build-up and collapse of the magnetic field in the low-tension winding of the coil. This fluctuating magnetic field induces a high-voltage current in the secondary winding of the ignition coil which is transmitted to the spark plug via the rotor and contacts in the distributor cap. A condenser is wired across the breaker points to reduce arcing at the points when the low-tension magnetic field in the coil collapses.

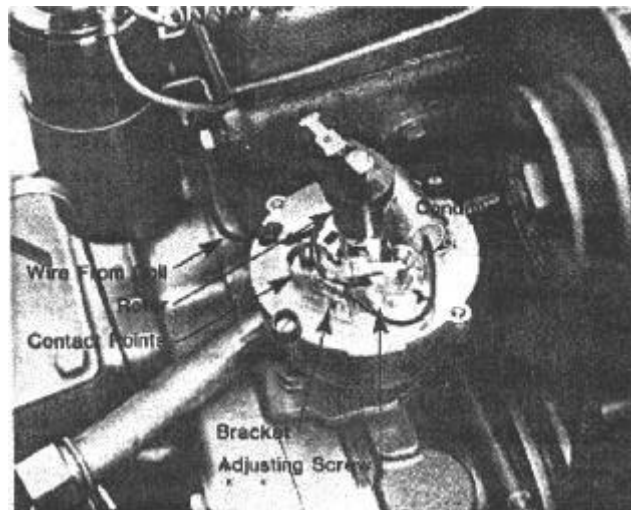

**FIGURE 9 - ADJUSTING IGNITION POINT GAP**

## IGNITION SYSTEM COMPONENT REPLACEMENT

### Ignition Point Replacement

Points which show only a slight discolouration and are not badly pitted should be cleaned with a special contact point file and reset to 018"-.020" gap. To replace the contact point assembly, proceed as follows:

#### CAUTION

**Make certain that the ignition switch is off.**

1. Remove distributor cap held by two double-slotted screws which remain with cap.
2. Pull rotor off shaft to allow access to contact assembly.
3. Remove negative terminal and condenser wire terminal from the inner portion of the insulated bracket (see Figure 9).
4. Remove screw holding contact assembly and remove assembly by gently lifting upward. When installing new assembly be sure to press tightly into position on distributor plate mounting stud.
5. Position condenser bracket so that condenser is clear and not touching point assembly.
6. Push connectors from the condenser and the negative post on coil onto the spring-loaded terminal in distributor.
7. Secure assembly lightly in mid-position of adjusting slot.
8. Turn the engine over counter-clockwise by hand until one of the four cams on the distributor opens the points to maximum. Using a feeler gauge, adjust point opening with screwdriver in adjusting slot to provide .018" to .020" gap clearance.
9. Replace rotor and cap.

#### NOTE

**It is recommended that the contact assembly and condenser be replaced at the same time to reduce the risk of pitting on point contact surfaces.**

### Ignition Coil Replacement

With ignition off, disconnect the wires from the negative and positive terminals of the coil, remove the high-tension wire and loosen the two bracket bolts and the bracket clamp screw.

### Spark Plug Replacement

Refer to Chapter 2 - Maintenance, for details of spark plug servicing and replacement.

## STARTER MOTOR

Removal/Installation (see Figure 10).

1. Disconnect the battery ground cable.
2. Disconnect the battery cable from the starter solenoid, the wire from the starter switch (yellow-red) and the wire from the ammeter (red).

### CAUTION

**Support starting motor while removing mounting bolts.**

3. Remove two mounting bolts and withdraw starting motor from flywheel housing.
4. Installation is the reverse of removal.

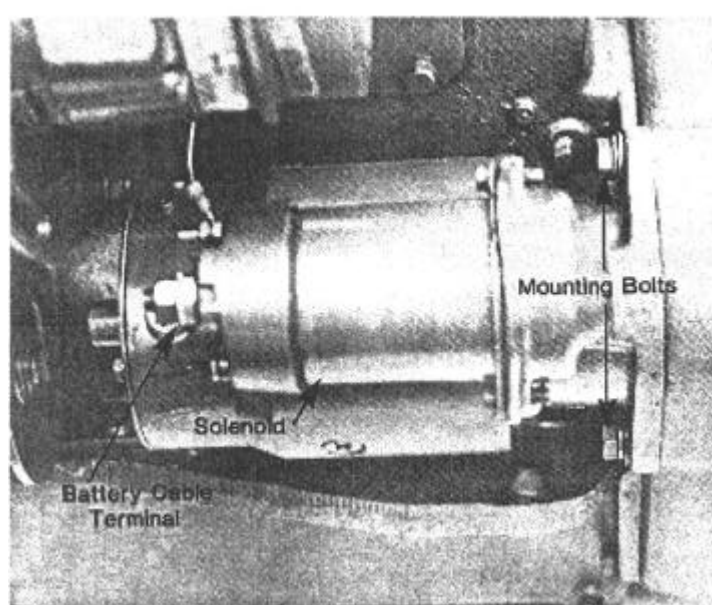

**FIGURE 10 - STARTER MOTOR REMOVAL**

### Installation and Service

To inspect the condition of the "gear" drive, commutator and brushes the motor must be partially disassembled. Remove the solenoid and end cap to expose the brushes. Pull on the brushes to ensure that they slide freely in their holders. If the flexible lead is nearly touching the metal holder the brushes should be replaced. Examine the commutator for wear or scoring. Service to the solenoid and starter should be carried out by a dealer or automotive-electrical repair shop.

## ALTERNATOR AND VOLTAGE REGULATOR

The alternator generates alternating current (AC) which is converted to direct current by internal silicon diodes. The voltage regulator controls the rate of charge (amperes) and voltage to the electrical system.

Adjustment and repair of these units requires special equipment not ordinarily available to the amateur mechanic. If malfunction occurs remove the units and take to a dealer or competent automotive-electrical repair shop.

Common problems and probable causes of alternator and voltage regulator malfunctions are:

1. Screaming during acceleration: The V-belt is loose or has deteriorated, or both. Tighten or replace.
2. Constant growling: The bearing on the pulley end of the shaft is defective. Have it replaced.
3. Alternator doesn't charge: Loose V-belt, defective brushes or slip rings inside alternator, defective regulator, blown rectifier diodes, open field circuit to regulator, open circuit between alternator and battery, open circuit between regulator and ignition.
4. Unsteady, irregular charge: Loose V-belt, poor connections, loose mounting hardware and poor ground connection.
5. Excessively high charging rate; Defective regulator.



## Removal Installation

1. Isolate battery or disconnect positive cable at battery.
2. Disconnect two wires and tag for re-installation (see Figure 11).
3. Remove mounting and belt tension adjusting bolts and drive belt.
4. Installation is the reverse of removal.
5. Adjust drive belt tension by moving alternator away from engine until drive belt can be deflected  $\frac{1}{2}$  to  $\frac{3}{4}$  inch. Tighten adjustment and mounting bolts (see Figure 5).

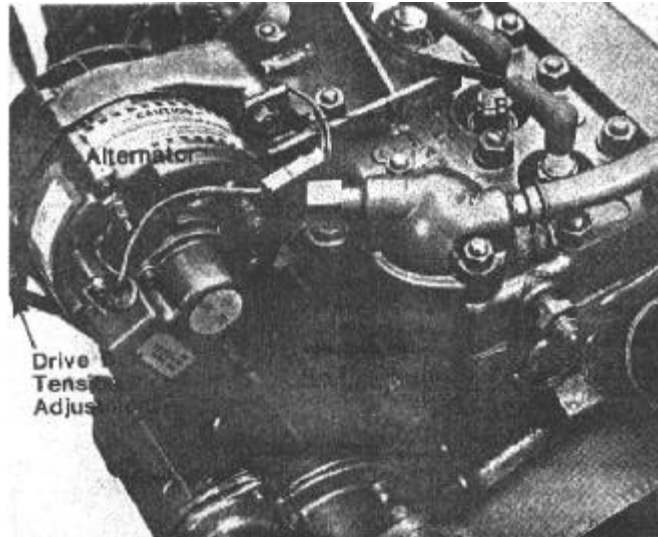

**FIGURE 11 - ALTERNATOR REMOVAL**

## IGNITION TIMING ADJUSTMENT

1. Remove spark plug from No.1 cylinder (at fly-wheel end of engine).
2. Place thumb over spark plug hole and turn engine by hand until compression pressure is felt.
3. Turn flywheel in normal cranking direction (counter-clockwise)~ until cranking pin is exactly vertical.  
No.1 piston is now at top~dead-center (TDC).

### NOTE

**Do not lift distributor, which will disengage distributor drive gear, or complete retiming may be required.**

4. Loosen distributor clamp bolt and rotate distributor body until breaker points are just beginning to open.
5. Tighten distributor clamp bolt. Engine is now roughly timed.

6. Replace and fasten distributor cap. Number 1 spark plug wire goes into the connection directly above the flat on the distributor body at which the rotor is pointing. The remaining three high tension wires are inserted in the distributor cap in the proper firing order (1-2-4-3) going from No.1 in a clockwise direction.
7. Final timing adjustment must be made with the engine running.
8. With engine running at a fixed speed, loosen distributor and rotate for maximum engine RPM at that throttle setting Re-tighten distributor clamp bolt.

## DISTRIBUTOR MAINTENANCE

### Removal (see Figure 12)

1. Remove the distributor cap held by two double-slotted screws which remain with cap.
2. Disconnect the wire connected to the coil negative terminal
3. Loosen the clamping bolt at the base of the distributor.

#### NOTE

**Do not rotate the engine after removing the distributor**

4. Note the position of the distributor in relation to the engine, to facilitate replacement in the same relative position.
5. Remove distributor from engine.

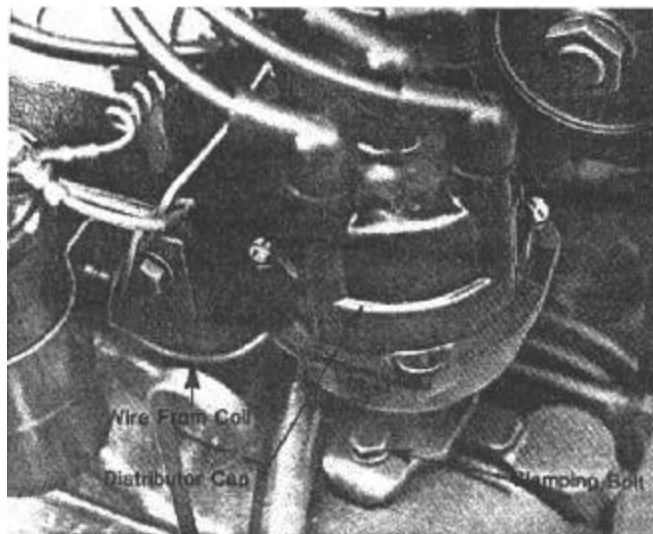

**FIGURE 12- DISTRIBUTOR REMOVAL**

## Inspection

1. Inspect the distributor for cracked, broken or worn parts including advance mechanism and for excessive burning. Replace all defective parts.
2. Clean all parts with carbon tetrachloride.

## Installation

1. Replace the distributor in the same position as it was when removed.
2. Tighten distributor clamping bolt.

## BATTERY MAINTENANCE

The battery supplies current to the starter and electrical system while starting the engine. After the engine starts, the alternator supplies all the current required to keep the engine running, and also replenishes the current supply drained from the battery during starting.

The state-of-charge of the battery is indicated by the specific gravity of the battery solution. Check the specific gravity with a hydrometer to determine the condition of the battery. A battery which is used in tropical climates, where freezing rarely occurs, is supplied with a weaker acid solution, resulting in lower specific gravity values. A high specific gravity affords the best protection against freezing. A difference in specific gravity between cells of 20% and 25% indicates battery trouble and the possibility of early failure, especially in cold weather.

Rapid loss of battery solution is an indication that the battery is being overcharged. The alternator and voltage regulator should be checked and adjusted to provide the specified output.

Hydrometer testing is the most effective way of determining battery condition. Use a hydrometer with numbered graduations from 1.100 to 1.300. To test the cell, squeeze the rubber ball, insert the tip into the cell and release the ball (see Figure 13). Draw enough fluid from the cell to float the weighted float in the hydrometer. Note the number on the float in line with the surface of the electrolyte fluid. Return the electrolyte to the proper cell and repeat for each cell.

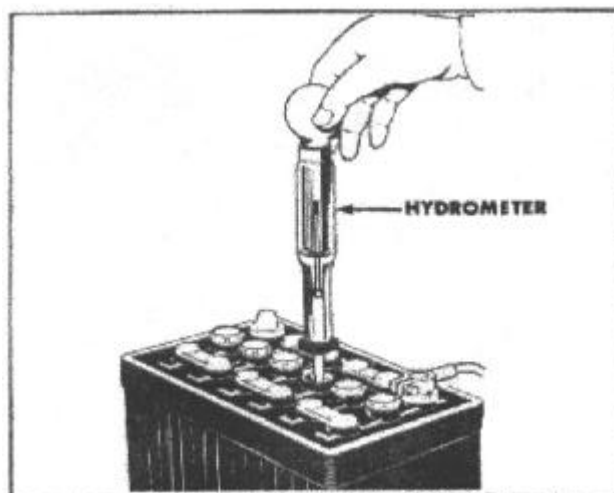

**FIGURE 13 - CHECKING SPECIFIC GRAVITY**

The specific gravity of the electrolyte in each cell is an accurate indication of the cell's condition. Refer to the chart below to determine the condition of the battery.

The fluid level in the cells should fully cover the battery plates. Add only distilled water to the battery. Keep open flames and sparks away from battery.

<b>Specific Gravity Temperature Climates</b>	<b>State of Charge</b>	<b>Specific Gravity Tropical Climates</b>
Above 1.280	Fully Charged	Above 1.225
1.250	75%	1.220
1.220	50%	1.175
1.190	25%	1.150
1.160	Limited Useful Capacity	1.120
1.130 or less	Discharged	1.090 or less

## **FUSES**

Note that on later model engines (20 and 10 amp) fuses are mounted behind the instrument panel to provide protection for the ignition and blower circuits. In addition, a 3 5-amp fuse is fitted in the wire (red) connecting the starter solenoid and the ammeter to provide protection for the starter motor (see Figure 14).

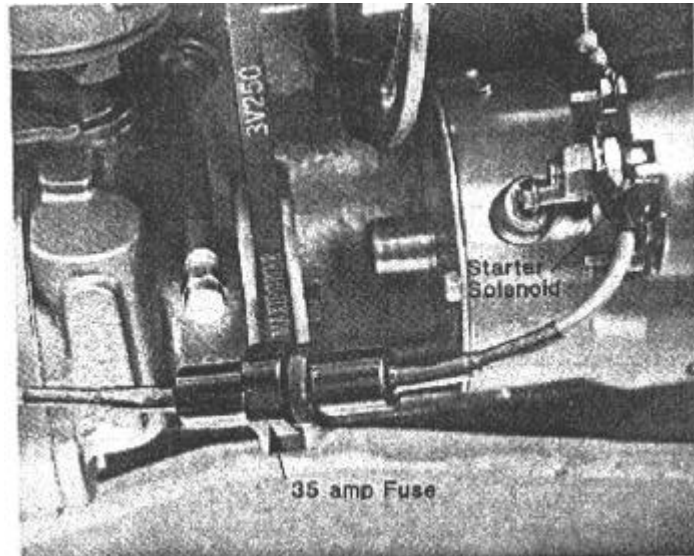

**FIGURE 14 - STARTER CIRCUIT FUSE**

### **WIRE SIZES**

Correct wire size selection is important for safe and proper operation of auxiliary electrical equipment. The table below indicates recommended wire size based on total current for the circuit and length of run. For battery cables use No. 1 heavy duty cable.

### **WIRING DIAGRAMS**

Wiring diagrams are included for engines with and with-out electric fuel pump, 5-unit instrument panel, and generator equipped engines (see Figures 15 to 18).

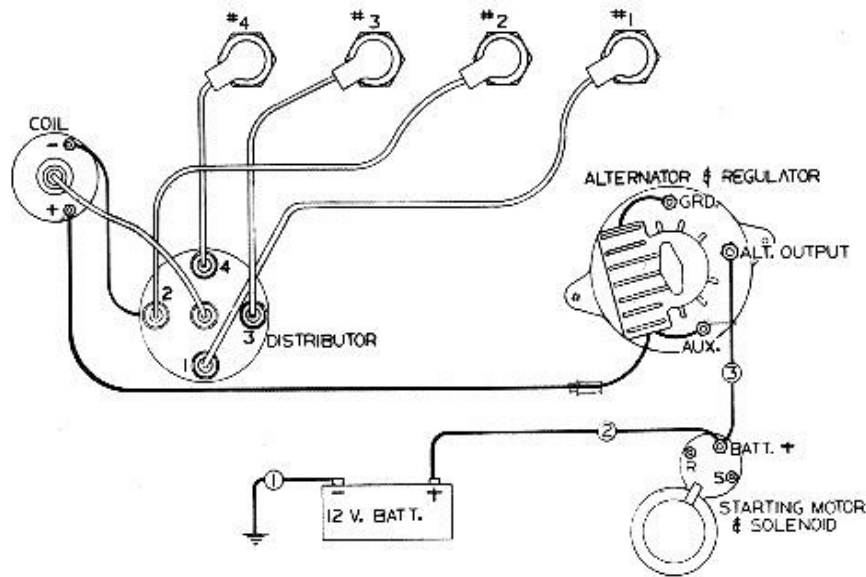

**FIGURE 15 - ENGINE WIRING DIAGRAM (WITHOUT INSTRUMENTS)**

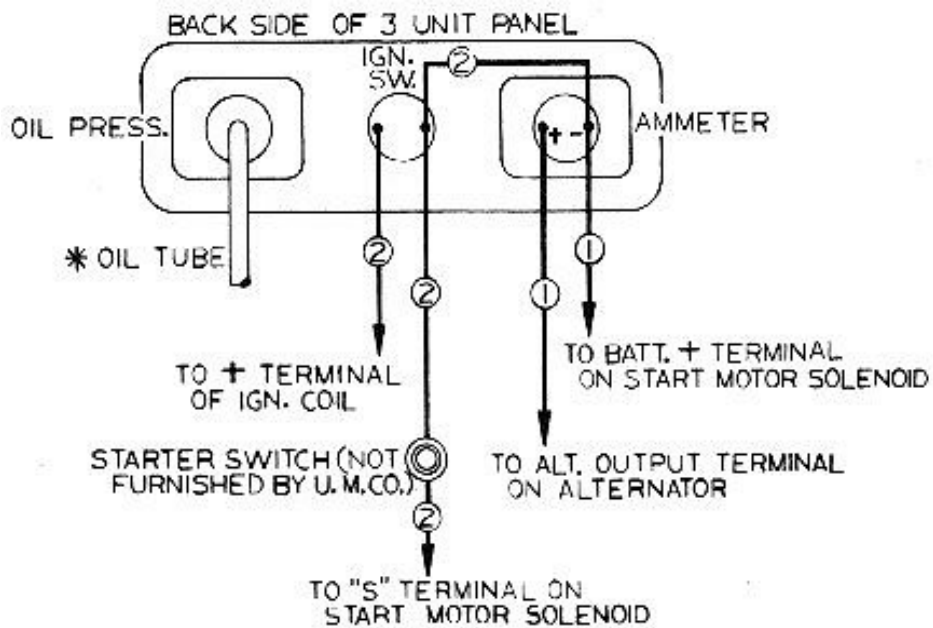

**FIGURE 16 - INSTRUMENT PANEL WIRING DIAGRAM**

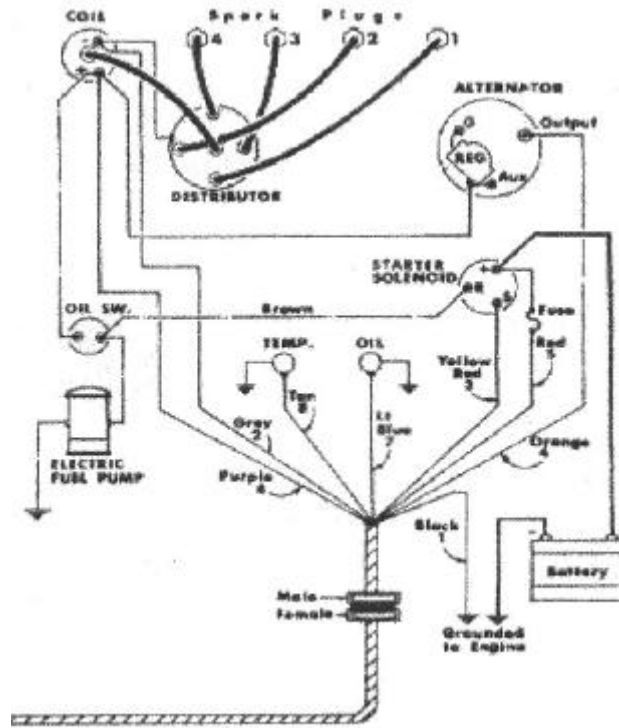

FIGURE 17 - ENGINE WIRING DIAGRAM

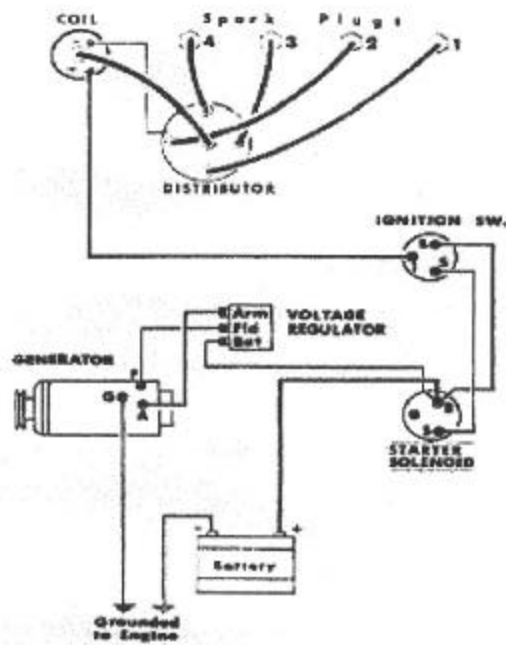

FIGURE 18 - ENGINE WIRING DIAGRAM  
(WITH GENERATOR)

## FUEL SYSTEM

The fuel system consists of the fuel tank and lines, fuel pump, carburetor, flame arrester and intake manifold. Gasoline enters the fuel pump from the tank and is pumped into the carburetor float bowl. The fuel is vaporized in the carburetor and drawn into the engine through the manifold and intake valves.

### TYPICAL FUEL SYSTEM

The main components of a typical marine engine fuel system are shown in Figure 19 and discussed below

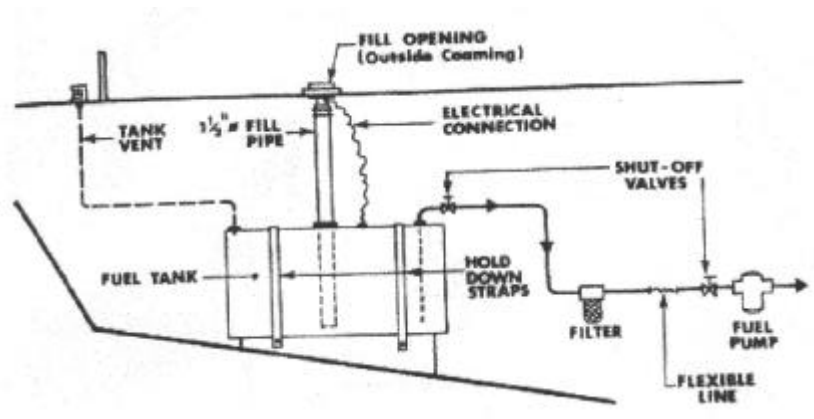

**FIGURE 19 - TYPICAL FUEL SYSTEM**

The fuel tank should be designed for marine use with internal baffle plates and a filler pipe extending to within a few inches of the bottom. The outlet should also be on the top of the tank so that if the fuel line fails only a small amount of gasoline will enter the hull. A vent connection must be provided to allow fumes to escape from the tank.

Other features of the installation include a replaceable fuel filter and static ground connection between the fuel tank and the fill fitting on deck.



## FUEL PUMPS

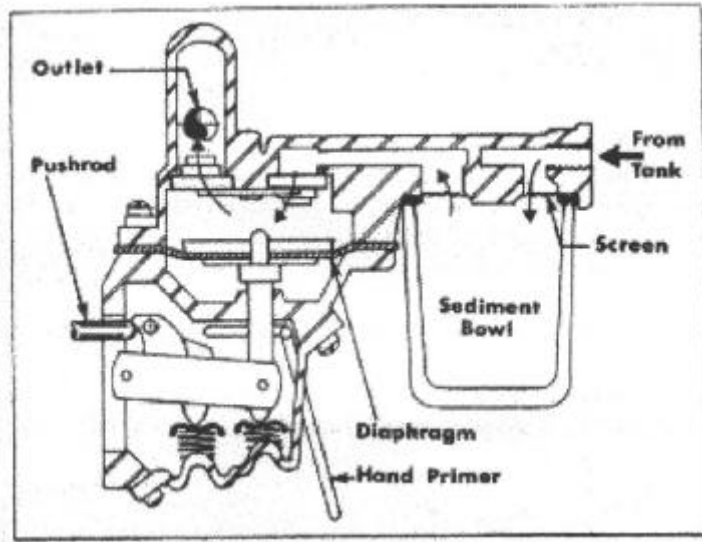

**FIGURE 20 - MECHANICAL FUEL PUMP**

The function of the fuel pump is to supply an adequate amount of gasoline to the carburetor for all engine speeds.

The mechanical fuel pump is of the diaphragm type operated by a push rod acting off an eccentric cam on the camshaft

At the high point of the cam, the push-rod is forced down creating a vacuum above the diaphragm which draws fuel from the tank into the pump through the inlet valve. The reverse stroke of the push-rod releases the compressed diaphragm spring forcing fuel through the pump outlet valve and into the carburetor float bowl.

After a number of strokes, the carburetor float-bowl fills and the bowl inlet is sealed off by the rising float mechanism and the seating of the float-bowl needle valve, creating back pressure on the pump diaphragm. With this back pressure on the diaphragm, rocker arm movement is taken up by the linkage instead of the diaphragm, and fuel flow to the carburetor is reduced until the level falls in the float-bowl at which time additional fuel is required. Fuel flow rate continuously fluctuates depending upon engine requirements.

Later engines are equipped with an electric fuel pump operating independently of the engine by means of an integral electric motor.

## **FUEL PUMP (MECHANICAL) (see Figure 20)**

Defective fuel pumps should be removed and replaced.

### **Removal**

1. Shut off fuel supply to fuel pump.

### **WARNING**

**Drain and dispose of any fuel when fuel lines are disconnected and pump removed.**

2. Disconnect fuel lines at pump inlet and outlet.
3. Remove two mounting bolts securing pump to engine and remove pump.
4. Withdraw push-rod from engine opening
5. Remove pump sediment bowl, screen and gasket. Drain pump and bowl and dispose of fuel.

## **FUEL PUMP (ELECTRICAL)**

Electrical fuel pumps are not repairable in the field. A faulty pump must be replaced. Note that a low-oil-pressure switch is installed in the fuel pump electric circuit. Failure of this switch or wiring will prevent operation of the fuel pump.

Servicing of the electrical fuel pump is limited to replacement of the disposable filter which is accessible after removing the lower cap from the pump. The filter should be replaced annually.

### **Removal and Installation**

1. Make certain ignition is off.
2. Shut off gas supply.
3. Disconnect the inlet and outlet fuel lines at the pump and dispose of fuel from lines.
4. Disconnect the pump electrical wire at the low-oil-pressure switch.
5. Remove two pump mounting bolts.
6. Installation is the reverse of removal.

## CARBURETOR

The carburetor atomizes and delivers fuel to the engine in the amount and mixture required for all operating conditions. The fuel is vaporized and preheated in the intake manifold before entering the cylinders through the intake valves. A flame arrester, fitted at the carburetor throat, prevents fire from occurring from engine backfiring by dissipating heat through a series of curved plates.

Carburetors are of the updraft single-venturi design and allow operation to extreme angles.

Later engines (after serial No, 170509) are supplied with carburetors having only an idle adjustment. Earlier installations also provide high-speed (mixture) adjustment.

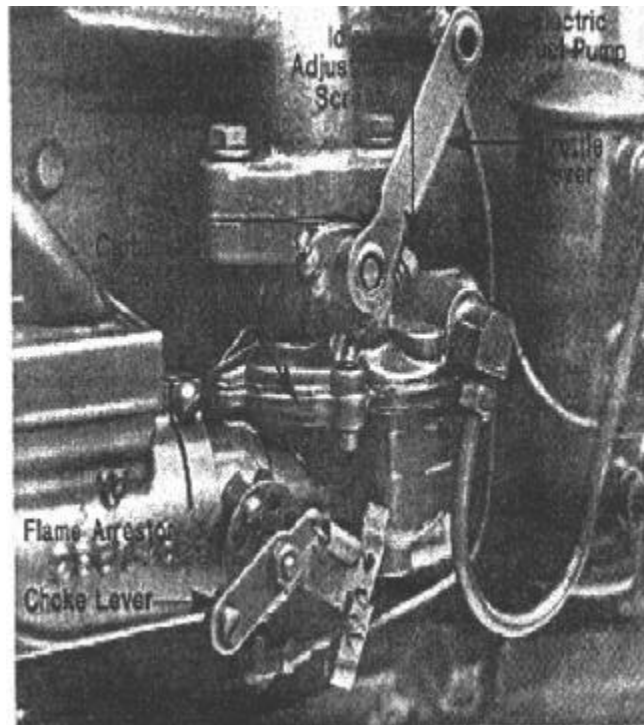

**FIGURE 21 - CARBURETOR IDLE ADJUSTMENT**

### Idle System Adjustment (see Figure 21)

1. Turn idling adjustment screw in until it seats, open one turn (to left) from seat.
2. With engine running and warm, close the throttle until a satisfactory idling speed is reached.
3. Adjust idling needle valve in (right) or out (left) for smoothest engine operation.
4. Set throttle stop screw for desired idling speed.

### High-speed Adjustment (Series 61 carburetors)

1. With engine running and warm, open throttle approximately one third.
2. Loosen packing nut on main jet adjustment.
3. Turn main jet adjustment to right (in) until engine runs smoothly and as fast as the throttle setting will permit.
4. Hold needle valve in this position and tighten packing nut.

### FUEL LEVEL FLOAT SETTING

Correct setting of the fuel level float located in the carburetor float bowl is essential for proper engine operation. These floats are factory set for a fuel pump pressure of 2 lbs. per sq. inch. Malfunction of the carburetor will sometimes be caused by dirt lodging on the float needle valve seat preventing complete seating of the needle valve. To inspect the setting and condition of the float mechanism, the carburetor bowl cover assembly must be removed.

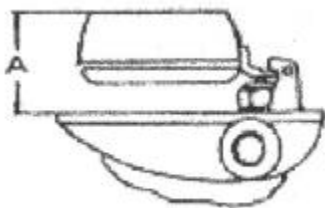

Series No.	Float Setting
61	1-9/64"
68	1-5/32"

**Float settings for Series 61 and 68 carburetors.**

With bowl cover assembly in an inverted position, viewed from free end of float, the float bodies must be centered and at right angles to the machined surface. The float setting is measured from the machined surface (no gasket) of cover to top side of float bodies at highest point.

To increase or decrease distance between float body and machined surface use long nosed pliers and bend lever close to float body. Replace float if position is off more than 1/16". Do not bend, twist or apply pressure directly to the float bodies.

## Choke Setting Adjustment

The choke consists of a shaft mounted “butterfly” valve located in the carburetor throat and operated remotely by an external lever. The choke is used to restrict air entering the carburetor thereby increasing the suction on the jets for engine starting. A poppet valve is provided on the choke plate to admit some air during starting to prevent over-chocking or flooding of the engine. At start-up, the engine requires a fuel/air mixture ratio much greater than that necessary during normal operation. The mixture ratio must be rapidly reduced once the engine starts and is accomplished by adjusting (opening) the choke valve as soon as the engine is running.

To set the choke for correct operation (engine not running) carry out the following:

1. Loosen choke control cable at carburetor lever and set choke valve in fully open position.
2. With choke control fully in, tighten control cable clamp at carburetor.
- 3.. Pull choke control out and check that the choke valve fully closes.
4. Re-adjust if necessary.

## Carburetor Removal

1. Shut off fuel supply.
2. Disconnect fuel inlet line and manifold air line.
3. Disconnect choke and throttle cables.
4. Remove two bolts securing carburetor to intake manifold and remove carburetor.

## Carburetor Installation

1. Install carburetor flange gasket and two mounting bolts.
2. Connect choke and throttle cables.
3. Connect manifold air line and fuel line.
4. Adjust choke and throttle controls.
5. Turn on fuel supply.
6. Check for fuel leaks.

## Carburetor Overhaul

A carburetor rebuilding kit is available from dealers. The kit contains parts which normally require service along with instructions for overhaul. Alternatively, carburetors may be serviced at a competent repair shop.

## COOLING SYSTEM

The Atomic4 cooling system is comprised of a positive displacement water pump and a thermostat to maintain proper engine operating temperature.

Figure 22 shows schematically the operation of the cooling system for cold and warm engines.

Four important points should be noted regarding the operation of the cooling system:

1. The water pump is designed to operate only when a water source is available to it. If the engine is run with the cooling water supply restricted or shut off; damage will quickly occur to the rubber water pump impeller.
2. If damage occurs to the rubber water pump impeller, one or more blades may break off and lodge in the cooling system hoses. If the engine is overheating, check the impeller for broken blades and if this has occurred, check all cooling water discharge hoses to see if the blades are preventing proper water flow.
3. The thermostat fitted is a special 3-spring bypass type which functions to provide water to the exhaust system regardless of engine operating temperature. Automotive-type thermostats must not be substituted for the factory supplied thermostat.
4. When laying the engine up for storage in below freezing areas, the cylinder block drain plugs located on the left side of the engine must be removed to positively drain the cylinder block and head. If anti-freeze is to be run through the engine as a winterizing fluid, one of the engine drain plugs should be removed so that all water in the cylinder block and head will be displaced by the anti-freeze.

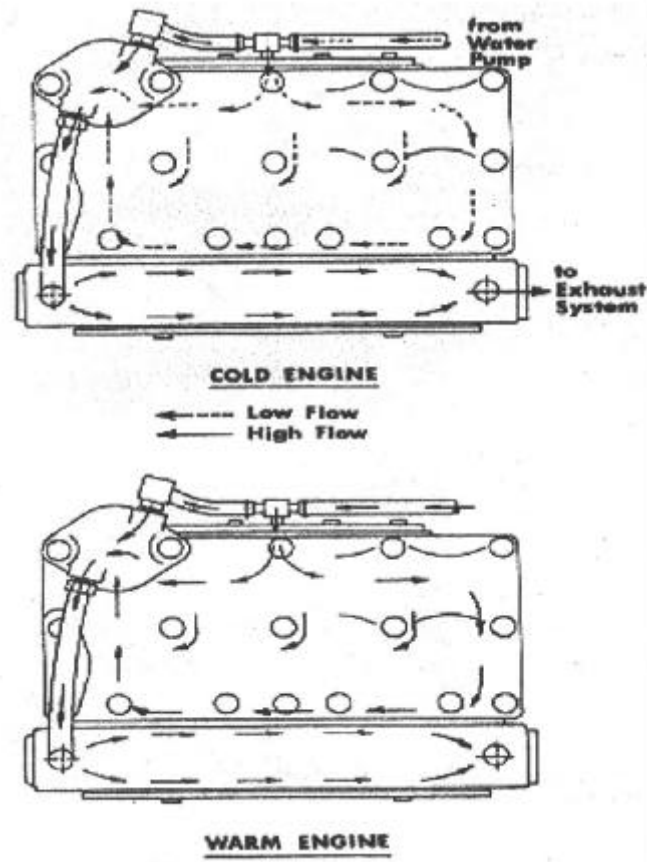

**FIGURE 22 - COOLING SYSTEM SCHEMATIC**

## **WATER PUMP**

### **Replacing Water Pump Impeller and Shaft**

1. Shut off water supply to pump. The water pump impeller and shaft may be replaced without removing the water pump from the engine.
2. Remove pump cover-plate held by four retaining screws.
3. Pull impeller and shaft out of water pump body.

#### **NOTE**

**Impellers are secured to the shaft with a removable pin or circlip.**

4. Remove pin or circlip securing impeller to its shaft (see Figure 23).
5. Installation is the reverse of removal

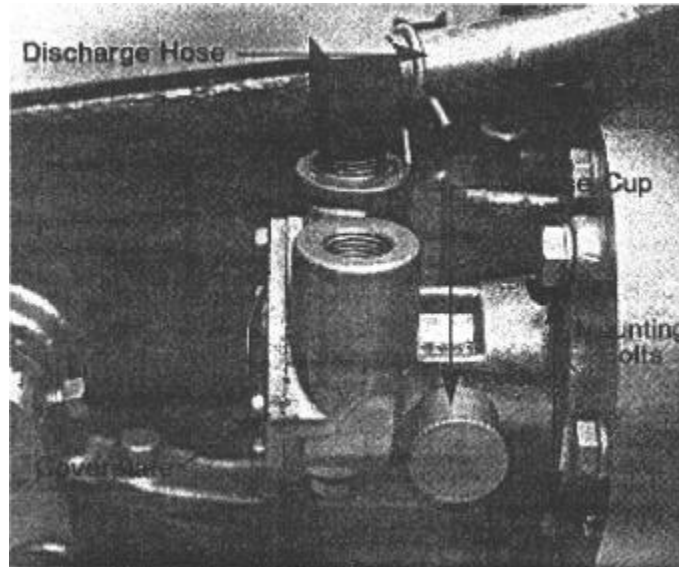

**FIGURE 24 - WATER PUMP REMOVAL**

If any impeller blades are missing remove the pump discharge hoses and thermostat housing and inspect for broken blades that may have lodged in the lines and which could cause restrictions and engine overheating.

**Removing Water Pump and Replacing Seals (See Figures 24 and 25)**

1. Shut off water supply to pump.
2. Remove the water pump from engine by disconnecting the suction and discharge hoses and removing two pump mounting bolts.
3. Remove cover-plate and withdraw impeller shaft assembly.
4. Remove grease cup and place pump body in vice with shaft opening upward.
5. Remove seals with expanding type seal removal tool. If this tool is not available, the seals may be removed with an offset tool through the shaft opening. Care must be taken not to damage the shaft bore surface.
6. Replace the inner seal first with the lip toward the impeller side; then the outer seal with the lip toward the drive end and flush with the mounting surface.
7. Inspect grease cup for free movement of ball and spring and fill with a good grade of water pump grease before replacing. To lubricate and seal shaft after installation, tum is felt to lubricate and seal shaft.



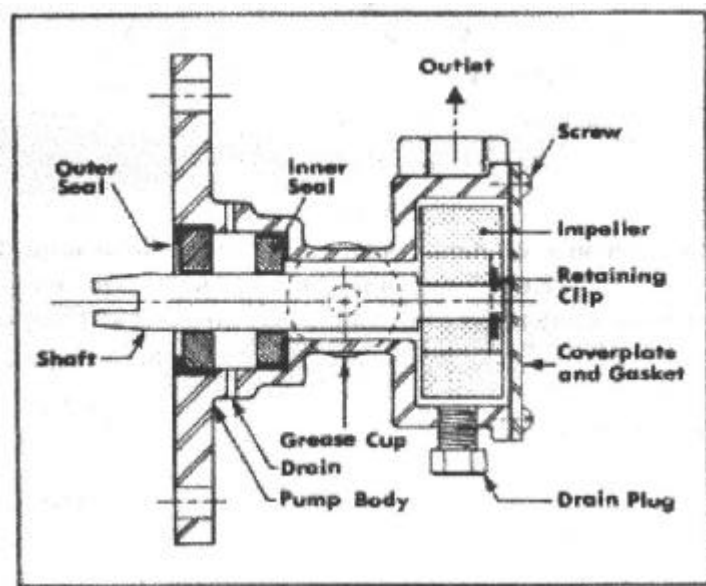

**FIGURE 25 - WATER PUMP CROSS SECTION**

## **ENGINE THERMOSTAT**

In-line thermostats before engine serial No.79476 are of the single-spring type and may be easily replaced by removing the two slotted cap-screws securing the main housing. Always install a new gasket when reassembling.

Engines beginning with Serial No.79476 have a special 3-spring by-pass thermostat installed in the cylinder head. This thermostat permits a continuous supply of water to the exhaust system, regardless of engine operating temperature. Do not use automotive-type thermostats as replacements for units supplied with your engine.

### **Removal and Installation (see Figure 26)**

1. Disconnect water inlet hose on thermostat housing.
2. Remove two thermostat housing nuts and carefully lift housing to expose thermostat.
3. When replacing thermostat be sure it is centred in the housing recess groove.
4. Clean gasket surfaces and instal a new gasket. Use only a light covering of sealant on gasket or alternatively, soak in warm water prior to installing.

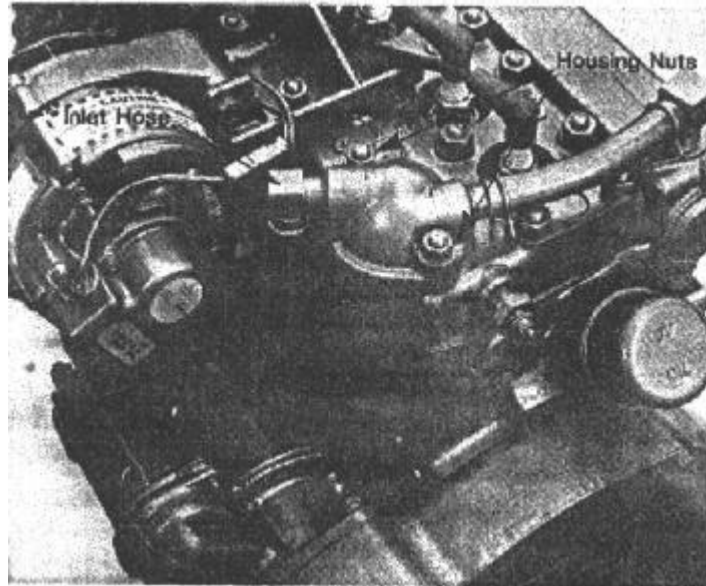

**FIGURE 26 - THERMOSTAT HOUSING**

**CAUTION**

**The two housing nuts also function as cylinder head fasteners and must be torqued to cylinder head specifications (35 ft. lbs. max.). Over-tightening of the housing nuts or tightening of nuts when the thermostat is not seated in the housing recess can result in over-stressing and cracking of the housing.**

5. Torque housing nuts to 35 ft. lbs. maximum
6. Install housing water inlet hose.

## ENGINE

This chapter provides procedures for carrying out adjustments and repair to the level of a minor overhaul (pistons, piston rings, connection rods and bearings, and valves) including cylinder head, manifold and crankcase pan removal. If repair or replacement of major components such as the crankshaft and camshaft or if cylinder re-boring is required, the engine should be removed for servicing by a competent repair shop.

### ADJUSTING VALVE CLEARANCE

Correct valve tappet clearances must be maintained to prevent valve damage, excessive noise and loss of power. If clearances are too small, valves may be burned or distorted. Large clearances result in tappet noise. In both cases, engine power is reduced.

Before adjusting valves, remove the spark plugs. This permits easier engine turning. Refer to Figure 27 for location of adjusting nut and Chapter 9 - Specifications for valve layout. Valve tappet clearances are shown in the table below.

<u>Valve Tappet Clearances</u>		
	<u>Hot</u>	<u>Cold</u>
Intake	.008"	.010"
Exhaust.	.010"	.012"

1. Remove fuel pump, carburetor, (see Chapter 4) and valve inspection cover on side of engine.
2. Turn the engine over so that piston No.1 is at TDC (top-dead-centre) on its compression stroke (see Chapter 3).
3. Hold the tappet locknut with an open-end wrench, insert a feeler gauge between the tappet and valve stem and adjust to proper clearance by turning the adjusting nut. Clockwise increases clearance and counter-clockwise reduces clearance.
4. Remove wrenches and check that clearance is correct.
5. Rotate engine counter-clockwise by hand until piston No.2 is at TDC on its compression stroke and adjust valves. Repeat for pistons No.4 and 3.
6. Re-install valve inspection cover, carburetor and fuel pump.

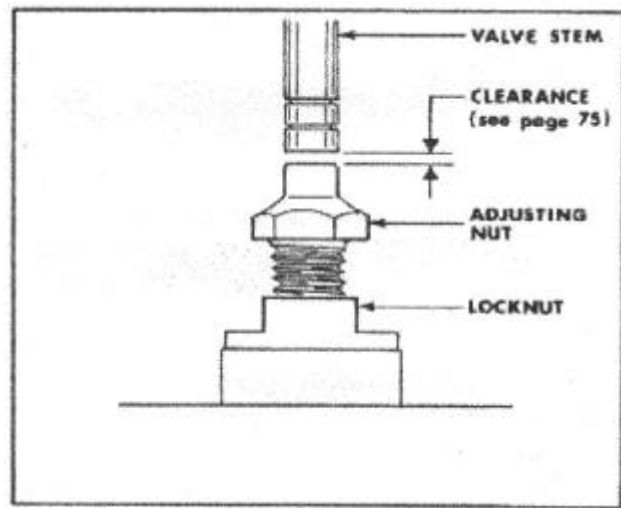

**FIGURE 27 - ADJUSTING VALVE CLEARANCE**

**REMOVING AND INSTALLING MANIFOLD (see Figure 28)**

1. Shut off cooling water supply and drain engine.
2. Disconnect and support exhaust at rear of manifold.
3. Disconnect water outlet hose at rear of manifold and thermostat housing outlet hose.
4. Remove carburetor (refer to Chapter 4).
5. Disconnect wire at water temperature sending unit
6. Remove three nuts securing manifold to engine and remove manifold.

**NOTE:**

**When reinstalling manifold, thoroughly clean mating surfaces and use a new manifold gasket**

7. Installation is the reverse of removal.
8. Torque manifold nuts to 35 ft. lbs.

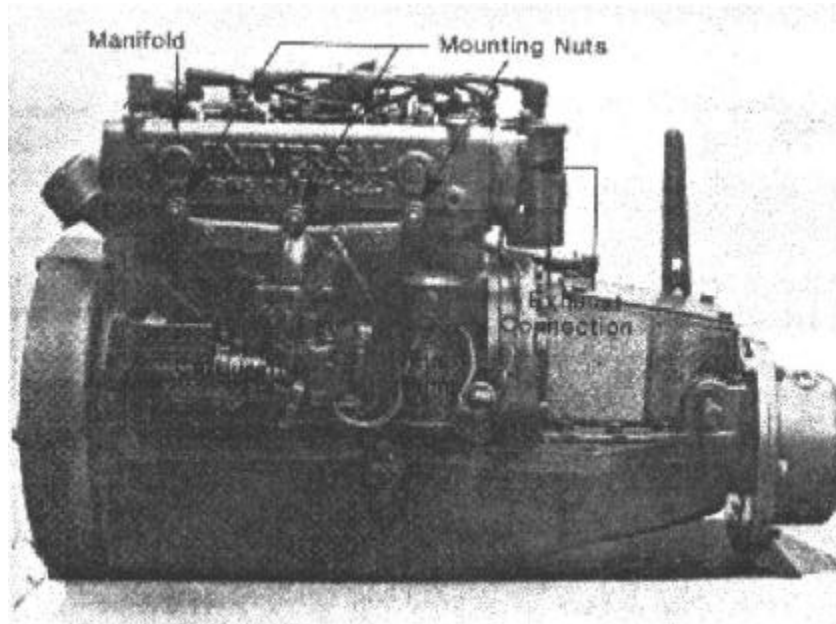

**FIGURE 28 - REMOVING MANIFOLD**

## **CYLINDER HEAD**

### **Removal**

Removal of the cylinder head will only be required when the valves need renewing, the engine needs de-carboning, or a damaged piston or head gasket is suspected. It is not usually necessary to take out the engine to remove the cylinder head, depending on available work space. To remove the cylinder head proceed as follows:

1. Shut off the cooling water supply to engine and drain engine.
2. Remove high-tension wires from spark plugs.
3. Remove alternator (refer to Chapter 3).
4. Remove carburetor (refer to Chapter 4).
5. Remove manifold (see above).
6. Disconnect the water inlet and outlet hoses at the thermostat housing.
7. Remove 7 head nuts (these include the two thermostat housing nuts) and alternator bracket.
8. Separate cylinder head from engine and remove,

After removing the cylinder head, cover the engine to protect the machined surface and prevent foreign matter from entering the cylinders.

## Inspection and Cleaning

1. Remove all carbon from the combustion chambers with a wire brush. A blunt screwdriver or chisel may be used if care is taken.
2. After removing all carbon, dean the entire head with solvent. Check for cracks. A cracked head must be replaced.
3. Using a straight edge check the cylinder head for warping. If the head is warped more than .006" it should be resurfaced or replaced.
4. Remove all gasket material from the cylinder head and engine.

### CAUTION

**Do not remove the carbon ridges at the top of the cylinder bores unless the pistons are to be removed.**

5. Clean all carbon from the piston crowns and valves. Inspect pistons and valves for wear or damage.

Check each cylinder for wear; if wear exceeds .0075", cylinders should be rebored for oversize pistons and rings or the engine block should be replaced.

If cylinder diameters are satisfactory but minor scratches or glazing is evident, restore cylinders to good condition by honing.

## Installation

### CAUTION

**Two head gaskets are required.**

1. Position two head gaskets and cylinder head on engine.
2. Locate alternator bracket thermostat and housing on cylinder head.
3. Install head nuts but do not tighten.
4. Tighten all head nuts to 35 ft. lbs. in proper sequence.

## REMOVING CRANKCASE PAN

- 1.. Drain oil from engine.
2. Remove reduction-drive or V-drive unit if equipped.
3. Remove two Allen-head bolts at transmission end of engine.
4. Remove starter motor, flywheel and flywheel housing.
5. Remove sixteen pan bolts and separate pan from engine.

**CAUTION**  
**Do not over-tighten pan bolts when reinstalling.**

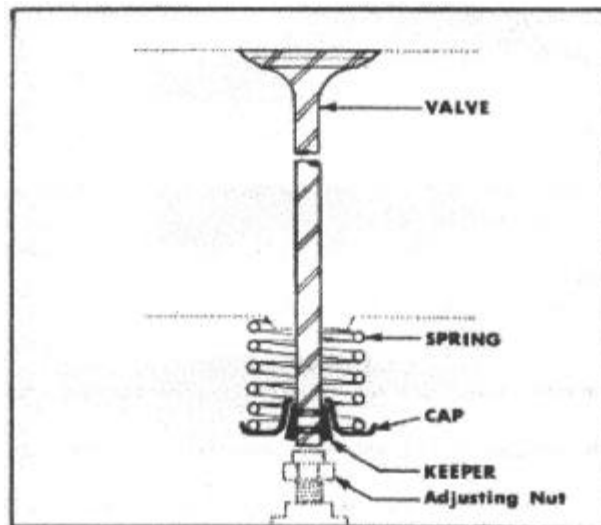

**FIGURE 30 - INSTALLING VALVE**

6. Installation is the reversal of removal. Clean pan and engine mating surfaces and instal anew pan gasket. Torque flywheel stud nuts to 35 ft. lbs.

### REMOVING PISTONS, CONNECTING RODS AND BEARINGS

Pistons and connecting rods may be removed after removal of the cylinder head and crankcase pan. To remove piston and connecting rods, proceed as follows.

1. Check the top of the cylinder for a carbon ridge. If there is a ridge, remove it before withdrawing the piston and rod.
2. Remove two nuts securing connecting rod bearing cap and remove cap. Note the position of the cap for reinstallation. The lower half of the connecting rod bearing insert may now be removed.
3. Separate the connection rod from the crankshaft. The upper half of the connecting rod bearing insert may now be removed.

**CAUTION**  
**Take care not to damage the cylinder wall when withdrawing the connecting rod.**

4. Push the piston and connecting rod up and out of the cylinder.
5. Reinstall the connecting rod bearing cap on the connecting rod.

## REMOVAL OF PISTON RINGS AND PINS

1. Remove piston rings using a ring expander tool.
2. Before removing the piston pin, hold the connecting rod firmly and rock the piston back and forth.  
Any rocking movement (do not confuse with sliding of the piston on the pin) indicates that there is wear in the piston pin, rod bushing, or piston pin bore.
3. Remove the snap rings at each end of the piston pin and press the piston pin out. This operation may best be left to your dealer or a machine shop where special equipment is available.

### Inspection

1. Clean the piston in solvent and scrape carbon deposits from the top of the piston and ring grooves. Take care not to damage the piston.
2. Examine the piston for damage and wear. Check each ring and groove for buns, damaged edges and side wear. Pay particular attention to the top compression ring, which usually wears the most.
3. Parts may be measured with a micrometer to determine which are worn and need replacement. (refer to Chapter 9 Specifications).

## PISTON RING FIT AND INSTALLATION

1. Check the gap of each piston ring by inserting it into its cylinder bore. Square it with the wall by tapping with a piston. Insert a feeler gauge as shown in Figure 31. Ring gap should be .007" to .015". If the gap is less than .007", place a small file in a vise, hold the ends of the ring, and enlarge the gap. If the gap is greater than .015", check the cylinder bore diameter which should be 2.562" to 2.563".
2. Roll each ring around its piston groove to check for binding.
3. Using a ring expander tool, carefully install the oil ring, then the two compression rings.
4. Check the side clearance of each ring in the piston ring groove and compare with specifications.



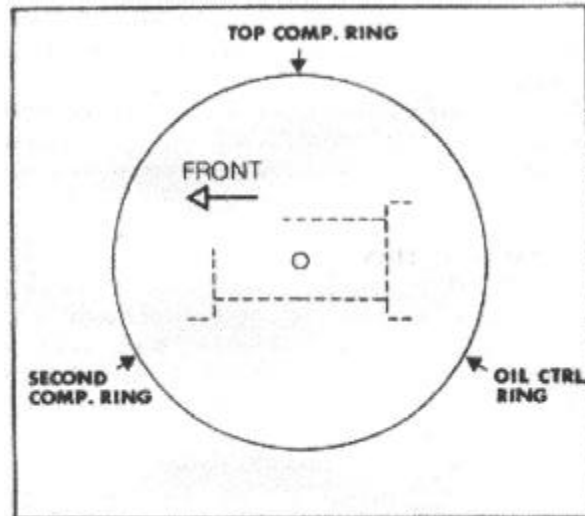

**FIGURE 31 - PISTON RING END GAP**

**CAUTION**

**Take care not to damage the cylinder hone when inserting connecting rod and piston.**

**NOTE**

**The piston is installed with the arrow pointing towards the transmission.**

5. Position the gaps of the piston rings as shown in Figure 32.
6. Coat the piston and ring with clean engine oil. Lubricate the pin and bearing and work rod back and forth to ensure that oil enters the pin beatings
7. Using a ring compressor, start the piston in the cylinder bore and tap the piston through the compressor and into the cylinder.

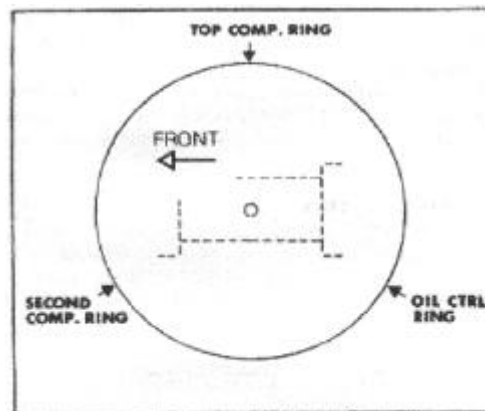

**FIGURE 32 - PITON RING GAP LOCATIONS**

## INSTALLING CONNECTING ROD BEARINGS

The upper rod bearing insert may be installed before the piston is inserted into its cylinder. Do not lubricate the surfaces where the rod and insert mate. After installing the piston in the cylinder lubricate the bearing insert, rotate the crankshaft so that the respective journal is at bottom dead center and push the piston down while guiding the connecting rod onto the journal. Snap the lower bearing insert into the rod cap and lubricate. Install the cap on the connecting rod and run the cap nuts up until the cap is snug. Turn the crankshaft one or two revolutions to center the rod on the journal and torque the cap nuts to 25 ft. lbs.

## REMOVING ENGINE

It may be necessary to remove your engine to carry out major repairs. After preparations have been carried out and the engine has been lifted off its bed, note the location of any shims under the engine mounts to facilitate realignment of the engine when it is reinstalled. A lifting eye is provided on the cylinder head. If engine disassembly is to be done after removal, the engine can be substantially lightened by prior removal of the crankcase oil, starter, alternator, manifold, cylinder head, and reduction gear unit. To remove the engine proceed as follows:

1. Disconnect the negative (ground) battery cable at the engine first, then disconnect the positive cable at the starter solenoid.
2. Shut off fuel, disconnect the fuel line at fuel pump and drain and dispose of fuel from lines.
3. Shut off cooling water supply to engine and disconnect hose from suction side of water pump.
4. Drain water from engine.
5. Disconnect the following:
  - exhaust at rear of manifold; support exhaust if necessary
  - water discharge hose at rear of manifold
  - propeller shaft
  - instrument wiring harness or individual wires at engine; tag wires for re-connection
  - oil line to pressure gauge, if equipped, drain and dispose of oil from line
  - shift lever control cable, throttle and choke control cables.
6. Remove four engine mounting bolts or nuts.

## TRANSMISSION ADJUSTMENTS

### Adjusting Forward Drive (see Figure 33)

1. Remove four transmission cover plate bolts and cover plate. Take care not to damage the cover plate gasket.
2. Loosen the lock screw until it is clear of the notch in the adjusting collar.
3. Turn collar to the right until the lock screw is in line with one of the notches in the collar.

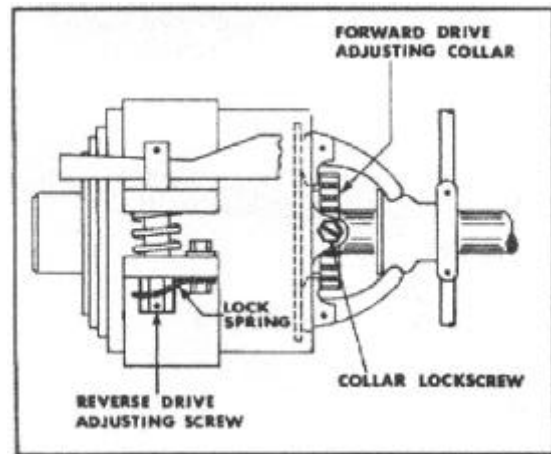

**FIGURE 33 - ADJUSTING TRANSMISSION**

4. Tighten the lock screw making certain that the end enters the collar notch.
5. Replace cover plate and try engine in forward drive. Repeat adjustment until no gear slip occurs on the forward drive. An adjustment of one or two notches is usually adequate to eliminate slippage.

### Adjusting Reverse Drive (see Figure 33)

1. Remove four transmission cover plate bolts and cover plate. Take care not to damage the cover plate gasket.
2. With shift lever in neutral, tighten adjusting nut two or three flats ( $1/3$  to  $1/2$  turn). Do not loosen the adjusting nut lock spring.
3. Replace cover plate and try engine in reverse drive. Repeat adjustment, if necessary, to eliminate slippage.

## Shift Control Linkage Adjustment

When shifting into forward or reverse drive, there must be positive engagement of the forward or reverse clutch, otherwise excessive wear will result. To check and adjust the shift control linkage proceed as follows:

1. Remove four transmission cover plate bolts and cover plate. Take care not to damage cover plate gasket.
2. Place the shift lever in the forward position as far as it will go.
3. Disconnect the linkage from the shift lever and check if the lever can be shifted further forward. If so, adjust the remote shift linkage to permit the shifting lever to move forward as far as possible and properly engage the forward drive.
4. Repeat adjustment for reverse drive position.
5. Replace transmission cover plate.

## TRANSMISSION and REDUCTION DRIVES

Your Atomic-4 will be equipped with one of three final drive arrangements: direct drive; 2:1 reduction; and V-drive with reduction.

Power is transmitted to the forward clutch or reverse drive gear in the transmission. The forward clutch consists of a number of friction discs which can be clamped together by the pressure plate operated by toggle arms mounted to the clutch adjustment plate. Manual positioning of the toggles determines forward, reverse, or neutral shaft output. The reverse clutch is operated when the shifting lever is moved to the rear of the engine, thereby clamping the brake band to the drum and preventing drum rotation and causing the tail shaft to be rotated in the opposite direction to the crankshaft. The forward and reverse clutches cannot be activated at the same time.

On models fitted with the reduction gear unit, two herringbone gears of different sizes supported by heavy-duty bearings function to reduce propeller shaft speed to approximately half of the engine speed. The reduction unit runs in a continuous oil bath (supplied from the engine crankcase) to provide positive and quiet operation.

The V-drive unit is made available to permit engine installation further aft while providing reduction of propeller shaft speed. This unit is lubricated and water cooled independently of the engine and requires very little attention. The V-drive unit is non-adjustable. Oil level should be checked periodically and water hoses and connections inspected from time to time. Water must be drained from the unit water jacket for winter storage.

## FINAL DRIVE MAINTENANCE

The transmission and reduction gear units require very little attention. These components are heavily built and will provide long trouble-free service when lubrication requirements, adjustments and winterizing (V-drive unit) are properly carried out. The most common malfunction is the failure of the rear oil seal caused by engine/shaft misplacement. Replacement of these seals should be carried out by a dealer or competent repair shop having the necessary special equipment for removal and installation. The reduction drive units can be easily removed from the engine for seal replacement.

### REMOVING/INSTALLING REDUCTION DRIVE UNIT (see Figure 34)

1. Disconnect shaft coupling, separate coupling halves and move propeller shaft aft two to three inches.

#### CAUTION

**Support reduction unit while re-moving mounting bolts.**

#### NOTE

**Place a container under the reduction unit and dispose of engine oil which will be lost when unit is removed.**

2. Remove six mounting bolts, separate reduction unit from transmission and lift unit up and back from transmission shaft.
3. Installation is the reverse of removal. Install a new housing gasket if necessary.
4. Top up engine oil level.

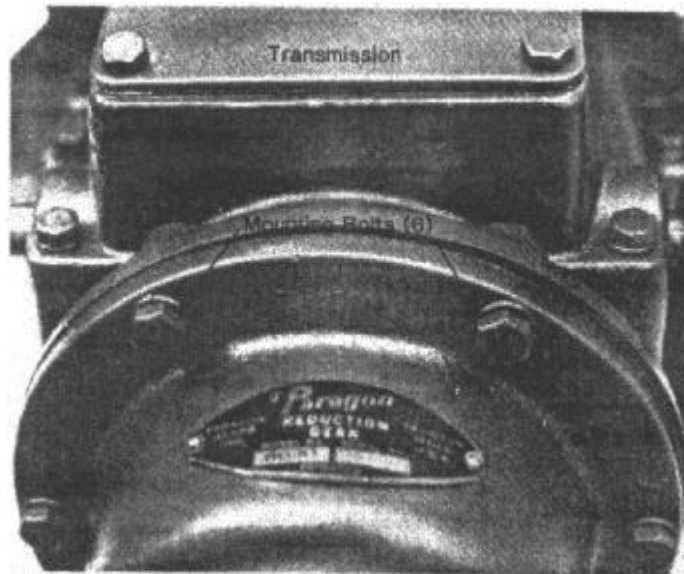

**FIGURE 34 - REDUCTION DRIVE REMOVAL**

### REMOVING/INSTALLING V-DRIVE REDUCTION UNIT

1. Disconnect shaft coupling.

#### **CAUTION**

**Support the V-Drive unit while removing mounting bolts.**

2. Disconnect cooling water inlet and outlet hoses.
3. Remove six mounting bolts and separate V-drive unit from transmission.
4. Drain and dispose of unit lubricating oil.
5. Installation is the reverse of removal.
6. Check and add oil as required after installation.

## SUPPLEMENTARY INFORMATION

### INTRODUCTION

This chapter contains information on other aspects of your engine including diagnosis of trouble, exhaust systems, alignment, propellers, refueling methods, recommended spare parts and tools. Proper maintenance of the sub-systems will increase operating reliability and reduce the need for expensive repairs and parts replacement.

### DIAGNOSING TROUBLE

Your engine has three main requirements for proper operation; a clean, adequate fuel supply; strong, uninterrupted ignition (spark); and good compression. If any of these conditions are not continuously present, the engine will not operate reliably. The following information will assist the owner in detecting and correcting the most likely causes of engine malfunction. When attempting to diagnose the problem, carry out only one procedure at a time.

### ENGINE WILL NOT START

<b>Cause</b>	<b>Action</b>
Ignition switch off or defective	Turn on or replace switch
Defective breaker points ignition coil or condenser	Remove high tension wire from distributor cap and hold approx. 3/8 "from engine block; crank engine; a clean sharp spark should be present clean and reset breaker points; if spark is yellow after adjustment, replace condenser; if spark is weak or not present, replace ignition coil.
Fouled or broken spark plug	Remove, inspect, clean and re-gap/replace plug.
Incorrect timing	Re-set timing.
Faulty distributor	Clean inside of distributor; inspect and replace broken or worn parts.
Damp ignition system and high tension wires	Dry system and wires.
Empty fuel tank	Fill fuel tank
Fuel shut-off valve closed	Open valve

Flooded engine	Remove spark plugs and turn engine over several times; replace plugs.
Water in fuel system	Clean fuel system and refill tank.
Choke valve inoperative	Check choke valve and control; re-pair, adjust as required.
Carburetor out of adjustment	Adjust carburetor.
Obstructed fuel lines or defective fuel pump	Clean fuel system; repair or replace fuel pump.
Air leak at intake manifold	Tighten bolts (replace gasket if necessary).
Loose spark plugs	Tighten spark plugs
Poorly seated valves	Check for broken or weak springs, bent stems, carbon deposits, insufficient tappet clearances.
Damaged cylinder head	Check for leaks when engine cranked and replace gaskets if necessary.
Worn broken piston rings	Replace as necessary.
Water in engine	Change engine oil; check for source of water (exhaust system, water pump, etc.).
Stale fuel	Drain and refill fuel tank.

### **STARTER MOTOR DOES NOT OPERATE**

Discharged battery	Charge battery
Corroded battery terminals	Clean terminals
Poor connection in starting circuit	Clean and tighten all connections
Defective starter switch	Replace Switch
Dirty starter motor brushes	Clean or replace brushes.
Jammed Bendix drive gear	Loosen starter motor and free gear



Defective starter solenoid	Service or replace solenoid.
Fuse defective (35 amp)	Replace fuse (located in red wire between ammeter and starter solenoid).
(20 amp)	Replace fuse (located behind instrument panel in wire between ammeter and ignition switch).
Partially discharged battery	Charge battery.
Damaged Bendix gear in starter	Repair gear..
Defective wiring or wiring of too low capacity	Check and replace as required.

### **TEMPERATURE TOO LOW/HIGH**

Defective temperature gauge or sending unit	Replace gauge or sender.
Defective water pump	Repair or replace pump.
Obstruction in cooling system	Remove obstruction (check for broken water pump impeller blades; outlet restrictions).
Defective thermostat	Replace Thermostat
Water intake sea-cock closed	Open sea-cock
Oil level low	Top up oil
Engine needs overhaul	Overhaul engine.
Overloading engine	Reduce engine rpm.
Engine timing incorrect	Reset timing.

### **OIL PRESSURE READING TOO LOW/HIGH**

Defective gauge, sending unit or oil tube	Repair or replace.
---	--------------------

No oil in engine	Add correct grade of oil.
Dirty pressure relief valve	Clean valve.
Defective or worn oil pump, leak in oil lines or broken pump drive	Replace pump or drive; tighten oil line connections.
Oil grade too light or heavy	Replace with proper weight oil
Weak or broken pressure relief spring	Replace spring.
Loose or worn engine bearings	Replace bearings.
Stuck pressure relief valve (high oil pressure)	Clean or replace valve

### **ENGINE VIBRATION**

Mis-firing or pre-ignition	Check spark plug condition, ignition timing; de-carbon engine
Loose mounting bolts	Tighten as required
Engine out of line	Align engine.
Propeller-shaft bent	Repair/replace shaft.
Propeller bent or pitch out-of-true	Repair/replace propeller.

### **LOSS OF POWER**

Damaged propeller	Repair/replace propeller.
Bent rudder	Repair/replace rudder
Engine misaligned	Align engine.
Stuffing box too tight	Adjust packing nut
Dirty boat bottom	Clean.
Incorrect valve tappet clearances	Adjust valve tappets.

Sticking valves

Free up by applying penetrating oil at valve stems (cylinder head may have to be removed).

### **PRE-IGNITION**

Defective spark plugs

Clean, adjust or replace plugs.

Improper ignition timing

Reset timing.

Engine carbon

Remove cylinder head and de-carbonize.

Engine overheating

See Chapter 5 - Cooling System.

### **BACK-FIRING**

Inadequate fuel supply

See Chapter4 - Fuel System.

Improper ignition timing

Reset timing.

### **ROUGH ENGINE IDLE**

Broken valve spring

Replace spring.

Carburetor dirty or out  
of adjustment

Clean and adjust carburetor

## EXHAUST SYSTEMS

One of the most important considerations in any engine installation is the exhaust system which must permit the exhaust gasses to be released as quietly and efficiently as possible, minimize back-pressure and prevent water from entering and reaching the engine itself. In addition, the exhaust must be kept cool despite the high operating temperatures of the engine. A compact and easily serviced system is desirable because of the restricted space encountered in most sailboats.

In most installations cooling water is discharged after mixing with the exhaust gasses thus aiding in keeping the exhaust system cool.

The water-lift type system (see Figure 35) is now almost exclusively used due to the advantages of being simple to install and repair and its adaptability to most vessels. Where possible, the muffler should be located close to and below the engine to minimize the amount of 'dry exhaust' required but in some cases this is not possible and a longer length of asbestos wrapped exhaust pipe must be used. It should be noted that the water-lift muffler is restricted in the vertical distance that the cooling water can be lifted.

## ENGINE ALIGNMENT

Proper alignment of your engine and drive shaft is essential to keep vibration and noise to a minimum and to reduce engine loading and wear. In extreme cases of misalignment the rear seal of the transmission or reduction gear can fail causing a significant oil leak.

To determine if an alignment problem exists it is necessary to separate the engine/shaft coupling halves and check the clearances between the two halves at the top and bottom and from side to side using a feeler gauge.

From these measurements it is possible to determine to what extent the propeller or engine output shafts or coupling faces are out-of-true and how much the engine needs to be moved on its mounts to achieve optimum alignment.

Any of these three conditions may cause noise and vibration:

1. true shaft couplings, engine misaligned
2. bent propeller shaft
3. out-of true couplings

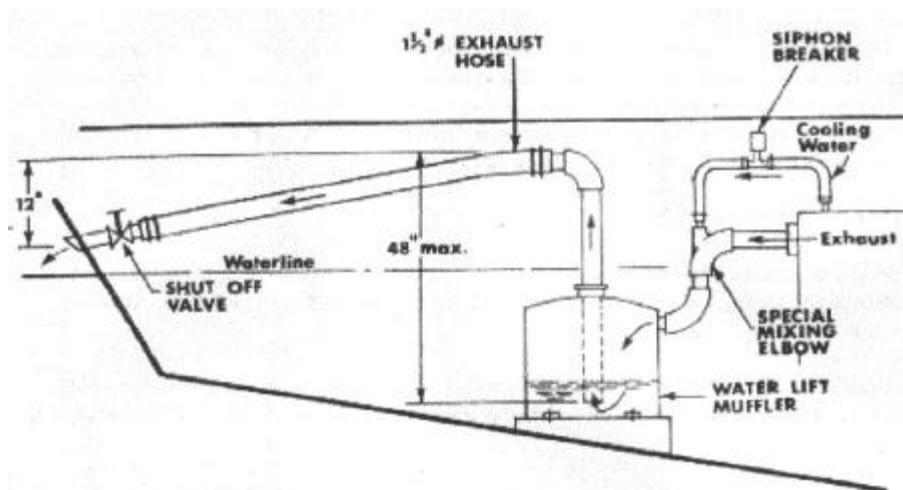

**FIGURE 35 - TYPICAL EXHAUST SYSTEM**

In the first case, the misalignment can be corrected by shifting the engine to bring the differences measured across the flange faces to as near zero as possible. In the second case, lining up the engine with an out-of-true shaft will result in some remaining vibration or shaft whip which can only be removed by correcting the bent shaft. An out-of-true coupling must be corrected to reduce the problem.

The objective should be to achieve a measured misalignment of no more than .0005" per inch of coupling diameter including out-of-trueness of shafts or couplings. (i.e. .002" for a four inch diameter coupling).

To determine the degree of engine misalignment and out of-trueness of shafts and couplings, it is necessary to mark the couplings; measure and record coupling clearances; calculate the vertical and horizontal misalignment and out-of trueness; determine the trueness of the flange faces and realign the engine and shaft to within acceptable limits.

The first step is to reduce the misalignment as much as possible. Mark the two flanges on the outer edges to provide reference points. Using a feeler gauge measure the clearance between the flanges at top, bottom and each side and record the measurements. The engine misalignment can now be corrected by shifting the engine on its bed and placing shims where required. By rotating the propeller flange and taking measurements at 90 degree increments, any shaft or flange face out-of trueness can be detected. Engine output shaft bind or flange misalignment can also be discovered by rotating the engine flange and taking measurements. If the out-of-trueness is found to be excessive (greater than .002") coupling flanges and/or the propeller shaft should be trued-up.

## **PROPELLER SELECTION**

In order to obtain optimum performance from your engine, the correct sized propeller must be installed. Incorrectly sized propellers produce cavitation and a substantial loss in thrust. Propellers are identified by diameter and pitch, with diameter measured at the tip of the propeller and pitch the distance travelled in one revolution of the propeller, disregarding slippage. For auxiliary sailboats, slippage may be assumed to be approximately 50%. For 2-bladed propellers, the diameter should be increased by at least 5%. Engines with a 2:1 reduction gear require a larger diameter propeller to compensate for the slow-turning propeller shaft. Note that propeller rotation for all engines (with and without reduction units) is right-hand.

Suggested propeller sizes for medium displacement auxiliaries are shown below.

## **PROPELLER SHAFT**

The minimum propeller shaft size should be 1" diameter for bronze or steel or 3/4" diameter if Monel is used. If the propeller shaft is over 5 feet long, an intermediate shaft bearing may be required. A zinc anode should be attached to the shaft close to the propeller to protect both against corrosion.

## **PROPELLER SHAFT STUFFING BOX**

In order to seal the opening where the propeller shaft penetrates the hull, an adjustable stuffing box is installed. The stuffing box usually consists of a hollow tube mounted in the hull through which the propeller shaft passes. After the shaft is installed the box is packed with three or four rings of suitable sized flax packing and the packing nut tightened by hand. After the packing nut is hand-tight, turn an additional half-turn with a wrench. Do not tighten further or the packing may be crushed.

With the engine running and shaft turning, check the stuffing box for leakage. There should be a slow drip. Periodically inspect the stuffing box and adjust the packing nut as necessary to maintain a slight drip. When the packing nut can no longer be tightened to provide a slow leak, the packing must be renewed. With proper care, shaft packing should last two or three seasons.

## REFUELING

Extra care must be taken when refueling and especially when restarting the engine after taking on fuel or when the boat has been left for an extended period. Prior to fueling, make sure that there are no open flames such as stoves or cigarettes. If possible, attempt to position the boat so that the fill point is leeward of the companionway so that fumes will be blown away from the boat. Keep the nozzle of the Gasoline hose in contact with the fill pipe to prevent a possible static electric spark. Clean up any fuel spills immediately. After fueling is completed run the engine room blower for at least five minutes. When the ambient humidity is high and there are light breezes, the danger of fumes accumulating in or around the boat is greater. Open the engine compartment and smell for fumes in the bilge before starting the engine.

## RECOMMENDED SPARE PARTS

The extent of spare parts that should be carried on board will depend on the type of sailing done and the degree of self-sufficiency that the owner wishes to have. Vessels used primarily in protected or coastal waters near urban centres will carry fewer spare parts than those on long trips, for instance on the Intra-coastal Waterway, or away from areas where parts distributors are numerous, e.g. the Carribean Islands, Mexico, etc.

A spare parts kits is available from dealers containing the minimum spares that should be carried aboard. This kit contains the following:

breaker points	1 set
distributor cap	1
spark plugs	4
condenser	1
alternator drive belt	1
thermostat housing gasket	1
water pump impeller and gasket	1 each
fuel pump filter (electric pump)	1

In addition to the spare parts list, the following parts are recommended for vessels on extended trips:

ignition coil	1
engine crankcase oil	4 quarts
fuel pump	1
oil pressure switch (for electric fuel pumps)	1
instrument panel fuses	2
fuse (starter) 35 amp	
water pump (complete)	1
water pump grease	1 pint
thermostat	1
carburetor overhaul kit	1
head gaskets	2
manifold gasket	1
3/8" hose	3 feet
high tension wire set	1
oil pump gear set	1
hand crank	1



## TOOLS

A basic tool kit should include at least the following to enable the owner to carry out necessary maintenance and repairs:

- set of open end or box wrenches 3/8" to 7/8"
- spark plug wrench
- several screwdrivers (various sizes)
- set of feeler gauges
- locking grip pliers
- long nose pliers
- adjustable open-end wrench
- hammer
- oil can
- special snap-ring pliers (for "Oberdorfer" water pump impeller retaining ring)

## OPTIONAL TOOLS

- 3/8". ratchet- drive and sockets
- torque wrench (0-75 ft. lbs.)
- wire cutters
- electrical multi-meter
- set of "Allan" set-screw wrenches (1/8" to 5/8")
- cold chisel

## SPECIFICATIONS

### GENERAL

Model Designations	5101-Direct drive 5102 - Reduction drive (2:1) 5103 - V-drive with reduction
Engine Type	Vertical, In-Line, 4-stroke, L-Head
Number of Cylinders	Four
Bore and Stroke	2.562 x 3.375 inches
Total Piston Displacement	64.46 cubic inches
Brake Horsepower	30@3500 rpm
Compression Ratio	6.3:1
Firing Order	1-2-4-3
Fuel	Regular grade gasoline (92-94 Octane)
Engine Idle rpm	600-1000 rpm
Engine Rotation	Counter-clockwise (when viewed from flywheel end)
Output Shaft Rotation	Counter-clockwise (all models)
Maximum Operating Angle	12-15 degrees (fore and aft)

### ADJUSTMENTS AND CLEARANCES

Spark Plug Gap	035 inches ("Champion RJ8,14 mm)
Ignition Timing	Breaker points starting to open at TDC (Top Dead Centre)
Distributor Point Gap	.018 to .020 inches
Magneto Point Gap	.014 to .018 inches
Valve Tappet Clearance	Intake: .008 - Hot .010-Cold Exhaust: .010 - Hot .012-Cold
Valve Sequence (from No. 1 cylinder)	Exh. - Int. - Int. - Exh.
Alternator Drive Belt	375 in. max. depression between Tension pulleys
Main Bearing Journal Diameter	1.9880 + .005,-.0000
Connecting Rod Journal Diameter	1.5625 +.0000,-.0005
Main Bearing Clearance- On Crankshaft	.001 to .0025
Connecting Rod Bearing Clearance	.002 to .0025
Connecting Rod Bore -Large End	1.6678 to 1.6687
Crankshaft End Play	.002 to .003 (At Front Bearing Only)
Connecting Rod End Play	.004 to .008 (Instal w/No. on Rod Toward Camshaft)
Camshaft Bearing Journal	1.2745 +. 0005 -.0000
Camshaft Bearing Clearance	.0015 to.0025 (Reamed after Installation)
Cylinder Bore	2.562 to 2.563 (Diameter Hone Finish)

(Install pistons with arrow pointing to transmission end. Instal compression rings with groove side up (Top of Piston).

### **Piston Ring Side Clearance (Width)**

Compression Ring Top	.0015 to .003
Compression Ring Center	.001 to .0025
Oil Ring	.001 to .0025
Piston Ring Gap Clearance	.007 to .015
Piston Skirt Clearance	.0015 Feeler to 5 lbs. pull
Piston Pin Size	.6380" Standard
Piston Pin Clearance in Piston	.001 to .002
Valve Seat Angle	45 degrees
Valve Seat Width	1/32"
Valve Stem Size	.3120 to .3115
Valve Stem Clearance In Guide	.002 to .003
Oil Pump Drive End Play	.001 to .003
Off Pump Gear Back Lash	.003 to .005
Camshaft Gear Back Lash.	.002 to .004
Idle Gear Back Lash	.002 to .004
Accessory Gear Back Lash.	.002 to .004

### **TORQUE DATA**

Cylinder Head Stud Nuts	35 ft. lbs. - (Engine Hot)
Manifold Stud Nuts	35 ft. lbs. - (Engine Hot)
Connecting Rod Bolt Nuts	25 ft. lbs.
Flywheel Stud Nuts	35 ft. lbs.
Main Bearing Nuts (front and rear)	60 ft. lbs
Spark Plug	30 ft. lbs.

### **MISCELLANEOUS DATA**

Exhaust Flange	1-1/4" NPT (National Pipe Thread Size)
Water Inlet	3/8" NPT
Water Outlet	3/8" NPT
Fuel Pump Connection	1/8" NPT
Fuel Line	5/16" O.D. copper tubing

**OVERSIZE AND UNDERSIZE COMPONENTS AVAILABLE**

Main Bearing Set	-0.010 Undersize
	-0.020 Undersize
	-0.030 Undersize
Connecting Rod Bearing Set -	.010 Undersize
	.020 Undersize
	.030 Undersize
Piston Ring Set -	.010 Oversize
	.020 Oversize
	.030 Oversize
Piston W/Pin -	.010 Oversize
	.020 Oversize
	.030 Oversize
Piston Pin -	.005 Oversize
	.010 Oversize
	.015 Oversize

**SERIAL NUMBER LOCATIONS**

- On engine nameplate located on engine flywheel cover or manifold.
- Stamped in block directly above flywheel housing, under front oil filter.
- Stamped on upper left hand corner of block - ignition side.