

PL5

THE INTRAVENT

PLANETARY HYDRAULIC WINCH

DESIGN REVISION EFFECTIVE FROM SERIAL # 75036

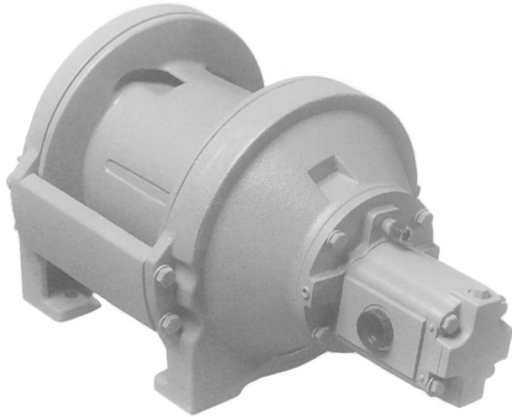

INSTRUCTION
AND
PARTS
MANUAL

EQUAL SPEED
EQUA SPEED



READ THIS MANUAL BEFORE INSTALLING, OPERATING OR SERVICING THIS PRODUCT. THIS MANUAL CONTAINS IMPORTANT INFORMATION. MAKE THIS MANUAL AVAILABLE TO ALL PERSONS RESPONSIBLE FOR THE OPERATION, INSTALLATION, SERVICING AND MAINTENANCE OF THIS PRODUCT.

Pull * **MASTER**

A **DOVER** COMPANY

THE LOGICAL
CHOICE

LIMITED WARRANTY

50130-0

Seller warrants that each article (whether Gear Drive Products, Brake Products and/or Winch Products, all of which are covered hereunder) sold under this order shall at the time of shipment (i) conform to applicable specifications, and (ii) be free from defects in material and workmanship during normal and ordinary use and service (the "Warranty").

Buyer's exclusive remedy and Seller's sole obligation under this Warranty shall be, at Seller's option, to repair or replace any article or part thereof which has proven to be defective, or to refund the purchase price of such article or part thereof. Buyer acknowledges that Buyer is knowledgeable concerning the articles covered by this Warranty and sold in connection therewith which are being purchased, that Buyer has reviewed this Warranty and that the remedies provided hereunder are adequate and acceptable to Buyer.

This Warranty shall expire one (1) year from the date the article is first shipped by Seller. Notice of claimed breach of this Warranty must be given by Buyer to Seller within the applicable period. Such notice shall include an explanation of the claimed warranty defect and proof of date of purchase of the article or part thereof for which warranty coverage is sought. No allowances shall be made by Seller for any transportation, labor charges, parts, "in and out" costs, adjustments or repairs, or any other work, unless such items are authorized in writing and in advance by Seller. Nor shall Seller have any obligation to repair or replace items which by their nature are expendable.

If an article is claimed to be defective in material or workmanship, or not to conform to the applicable specifications, Seller will either examine the article at Buyer's site or issue shipping instructions for return to Seller. This Warranty shall not extend to any articles or parts thereof which have been installed, used, or serviced otherwise than in conformity with Seller's applicable specifications, manuals, bulletins, or instructions, or which shall have been subjected to improper installation, operation, or usage, misapplication, neglect, incorrect installation, overloading, or employment for other than normal and ordinary use and service. This Warranty shall not apply to any article which has been repaired, altered or disassembled, or assembled by personnel other than those of Seller. This Warranty shall not apply to any article upon which repairs or alterations have been made (unless authorized in writing and in advance by Seller). This Warranty shall not apply to any articles or parts thereof furnished by Seller to Buyer's specifications and/or furnished by Buyer or acquired from others at Buyer's request.

SELLER MAKES NO EXPRESS WARRANTIES AND NO IMPLIED WARRANTIES OF ANY KIND, OTHER THAN THE WARRANTY EXPRESSLY SET FORTH ABOVE. SUCH WARRANTY IS EXCLUSIVE AND IS MADE AND ACCEPTED IN LIEU OF ANY AND ALL OTHER WARRANTIES, EXPRESS OR IMPLIED, INCLUDING WITHOUT LIMITATION THE IMPLIED WARRANTIES OF MERCHANTABILITY AND FITNESS FOR A PARTICULAR PURPOSE.

Buyer expressly agrees that Seller is not responsible to perform any work or investigation related in any way to torsional vibration issues and is not responsible for the detection or remedy of Natural Frequency Vibration of the mechanical system in which the unit is installed. Buyer acknowledges, understands and agrees that this Warranty does not cover failures of the unit which result in any manner from the operation of the machine or unit at vibration frequencies at or near the natural frequency vibration of the machine in such a way that damage may result. Buyer expressly agrees that Seller is not responsible for failure damage or accelerated wear caused by machine or ambient vibration. Further, Buyer acknowledges and agrees that Buyer is always solely responsible for determination and final approval of the "application factor" which may be used in Seller's calculations and this application factor is 1.0 unless otherwise stated in Seller's quotation specifications.

The remedies for this Warranty shall be only those expressly set forth above, to the exclusion of any and all other remedies of whatsoever kind. The limited remedies set forth above shall be deemed exclusive, even though they may fail their essential purpose. No agreement varying or extending the foregoing Warranty, remedies, exclusions, or limitations shall be effective unless in writing signed by an executive officer of Seller and Buyer. This Warranty is non-transferable. If a party who had purchased articles from Buyer, or from persons in privity with Buyer, brings any action or proceeding against Seller for remedies other than those set forth in this Warranty, Buyer agrees to defend Seller against the claims asserted in such action or proceeding at Buyer's expense, including the payment of attorneys' fees and costs, and indemnify Seller and hold Seller harmless of, from and against all such claims, actions, proceedings or judgments therein. Buyer also agrees to defend and indemnify Seller of, from and against any loss, cost, damage, claim, debt or expenses, including attorneys' fees, resulting from any claims by Buyer or third parties to property or injury to persons resulting from faulty installation, repair or modification of the article and misuse or negligent operation or use of the article, whether or not such damage to property or injury to persons may be caused by defective material, workmanship, or construction.

ADVISORY: Winches and hoists are not approved for lifting or handling personnel or persons unless specifically approved in writing from Seller for the specific intended application.

Under no circumstances shall Seller be liable (i) for any damage or loss to any property other than the warranted article or part thereof, or (ii) for any special, indirect, incidental, or consequential damage or loss, even though such expenses, damages, or losses may be foreseeable.

The foregoing limitations on Seller's liability in the event of breach of warranty shall also be the absolute limit of Seller's liability in the event of Seller's negligence in manufacture, installation, or otherwise, with regard to the articles covered by this Warranty, and at the expiration of the Warranty period as above stated, all such liabilities shall terminate. Buyer's purchase of any article(s) covered by this Warranty shall constitute acceptance of the terms and conditions hereof and shall be binding upon Buyer and Buyer's representatives, heirs and assigns. The laws of the Province of British Columbia shall govern Buyer's rights and responsibilities in regard to this Warranty and the transaction(s) subject thereto, and the Province of British Columbia shall be the exclusive forum and jurisdiction for any action or proceedings brought by Buyer in connection herewith or any dispute hereunder. If any of the terms and conditions contained within this Warranty are void, the remaining provisions thereof are and shall remain valid and enforceable.

SAFETY RECOMMENDATIONS



DANGER

FAILURE TO COMPLY WITH THE FOLLOWING SAFETY RECOMMENDATIONS AND LOCAL RULES AND REGULATIONS WILL RESULT IN PROPERTY DAMAGE, SEVERE INJURY OR DEATH.



Definition: **Caution** indicates a potentially hazardous situation which, if not avoided may result in minor or moderate injury.



Definition: **Warning** indicates a potentially hazardous situation which, if not avoided could result in death or serious injury.



Definition: **Danger** indicates a potentially hazardous situation which, if not avoided will result in death or serious injury.

PULLMASTER planetary hydraulic winches are made for hoisting and lowering loads and are to be operated by trained and professional personnel. They are not designed for operations involving lifting or moving personnel. The winches are powered by hydraulic power. The ropes / cables for hoisting operations are not supplied by PULLMASTER WINCH CORPORATION. The winches are always assembled in an application, they do not function as an independent machine and it is not allowed to use them as such.

The winches are to be used within the specifications as listed in the manual under "SPECIFICATIONS". Other use as foreseen in the functional description of the hydraulic winch is not allowed without written permission from PULLMASTER WINCH CORPORATION.

1. Do not install, operate or service winch before reading and understanding manufacturer's instructions.
2. The winch described herein is not designed for operations involving lifting or moving personnel.
3. Do not lift or carry loads over people.
4. Do not exceed recommended operating pressure (psi) and operating volume (gpm).
5. Do not jerk the winch. Always smoothly accelerate and decelerate load.
6. Do not operate a damaged, noisy or malfunctioning winch.
7. Do not leave a load suspended for any extended period of time.
8. Never leave a suspended load unattended.
9. Winch should be maintained and operated by qualified personnel.
10. Inspect winch, rigging, mounting bolts and hoses before each shift.
11. Warm-up equipment before operating winch, particularly at low ambient temperatures.
12. Verify winch function by raising and lowering a full test load to a safe height before each shift.
13. Do not weld any part of the winch.
14. Verify gear lubrication and brake circulation supply and return before operating winch.
15. Be sure of equipment stability before operating winch.
16. Wear proper clothing to avoid entanglement in rotating machinery.
17. Always stand clear of the load.
18. Use only recommended hydraulic oil and gear lubricant.
19. Keep hydraulic system clean and free from contamination at all times.
20. Maintain winch and equipment in good operating condition. Perform scheduled maintenance regularly.
21. Keep hands clear when winding wire rope onto the winch drum.
22. Do not use the wire rope as a ground for welding.
23. Rig the winch carefully. Ensure that the wire rope is properly anchored to the correct cable anchor slot at the cable drum.
24. Do not lift a load with a twisted, kinked or damaged wire rope.
25. Consult wire rope manufacturer for size, type and maintenance of wire rope.
26. Maintain five wraps of wire rope on the cable drum at all times.
27. In case of a power failure or breakdown leading to an unexpected stop of the hydraulic power circuit, stand clear of the area and the load being hoisted, take the necessary precautions to prevent access to area where the load is halted.
28. The noise level of the winch is 90 dBA measured on a distance of 1.00 meter, 1.60 meters high. The measuring equipment used was: Realistic #42-3019.
29. Clean up any oil spillage immediately.
30. Wear proper clothing and personal protection equipment such as, footwear, safety goggles and a hard hat. Read manual first.



DESCRIPTION OF THE MODEL PL5

GENERAL DESCRIPTION:

The PULLMASTER Model PL5 is a planetary hydraulic winch having equal speed in both directions. The main components of this unit are:

- + Hydraulic gear motor
- + Multi disc brake with static and dynamic function
- + Over-running clutch
- + Primary planet reduction
- + Final planet reduction
- + Brake housing
- + End housing
- + Cable drum

FUNCTION IN FORWARD ROTATION (HOISTING):

In forward rotation, the output torque and rpm of the hydraulic motor are transmitted to the sun gear of the primary planet reduction. The output of the primary reduction is transferred to the final sun gear, which is splined to the primary planet hub. The final planet assembly does not rotate, so the rotation is transmitted to the cable drum by the final drive planet gears. In forward rotation, or when a load is lifted, an over-running clutch, which connects the motor drive shaft to the automatic brake assembly, permits free rotation of the sun gear, without effecting the brake. Pressure required to rotate the drum at full speed without load may vary up to 400 psi (28 bar). When the winch rotation is stopped, the load on the cable drum causes the over-running clutch to lock and the maximum load is held safely by the disc brake.

FUNCTION IN REVERSE ROTATION (LOWERING):

In reverse rotation, or when the winch is pressurized for lowering a load, hydraulic pressure from the reverse side of the hydraulic motor is channelled to the brake piston, causing the brake piston to release the multi-disc brake against a number of brake springs. The pressure required to rotate the drum at full speed, depending upon load, may vary 250 psi to 500 psi (17 bar to 34 bar) and without load from 500 psi to 1000 psi (34 bar to 69 bar). The over-running clutch, connecting the motor drive shaft to the brake assembly, locks, causing the brake discs to rotate between divider plates, which are engaged into the brake housing. If the load on the cable drum tends to effect the lowering speed, the resulting pressure drop in the brake piston causes friction between the brake discs and the divider plates. In this way, a completely smooth paying out speed can be achieved in a stepless operation by modulation of the winch control handle. When the control handle is returned to neutral position, rotation stops and the disc brake applies automatically. A hydraulic counter-balance valve or holding valve is not required for smooth and positive operation of the automatic brake.

During the lowering operation of the winch, the friction created by the brake discs results in heat. This heat is dissipated by the circulation of hydraulic fluid through the brake housing, supplied internally through the hydraulic motor. This circulation flow is internally vented to the return line flow through a check valve arrangement inside the hydraulic motor. The circulation flow is supplied only when a load is lowered. A separate vent line connecting the PULLMASTER Model PL5 with the hydraulic reservoir is not normally required.

(See TYPICAL HYDRAULIC CIRCUITS.)

IMPORTANT: Pressure in the brake housing must never exceed 100 psi (7 bar). Excessive brake housing pressure will cause the safety valve located on top of the motor to leak. Brake housing pressure can be gauged at the safety valve port.

EXPLANATION OF MODEL CODING

PL 5 X - XX X - XX - XX X - XXXX

BASIC UNIT SERIES _____

SIZE OF UNIT _____

REDUCTION RATIO _____

Only used for non-standard reduction ratios
For "A" ratio: refer to appendix "B"

TYPE OF BRAKE _____

- 12 Automatic brake, counterclockwise hoisting, intravent
- 13 Automatic brake, external brake release, counterclockwise hoisting, intravent
- 14 Automatic brake, external brake release, clockwise hoisting, intravent
- 15 Automatic brake, clockwise hoisting, intravent

M _____

Denotes metallic brake plates

HYDRAULIC MOTOR _____

- 210 Gear motor - 33 cc displacement
(For optional motors refer to APPENDIX A)

DRUM SIZE _____

- 1 7.38 inch drum diameter x 11.00 inch flange diameter x 6.56 inch length - STANDARD
(For optional drum sizes refer to APPENDIX A)

OPTIONS _____

SPECIFICATION NUMBER _____

Describes features not identified by preceding codes

NOTE: Clockwise and counterclockwise drum rotation is the direction of rotation for pulling or hoisting, established by looking at the hydraulic motor.

OPTIONS

CLOCKWISE ROTATION:

The drum rotation of the standard PULLMASTER Model PL5 planetary winch is counterclockwise for hoisting, when looking at the hydraulic motor of the winch. Drum rotation for clockwise hoisting direction is available as an option.

EXTERNAL BRAKE RELEASE:

PULLMASTER planetary winches can be supplied with an **external brake release** which permits release of the automatic disc brake from an external pressure source.



DANGER

FAILURE TO PROPERLY VENT EXTERNAL BRAKE RELEASE PORT WILL TRAP BRAKE PRESSURE AND ALLOW THE LOAD TO DROP, CAUSING PROPERTY DAMAGE, SEVERE INJURY OR DEATH. WINCHES SUPPLIED WITH EXTERNAL BRAKE RELEASE OPTION MUST BE CONNECTED ACCORDING TO "TYPICAL HYDRAULIC CIRCUIT".

CABLE DRUM SIZES:

Aside from the standard drum sizes listed in APPENDIX A, the PULLMASTER Model PL5 planetary winch can be supplied with optional drums to accommodate large wire rope storage capacity.

DRUM GROOVING:

Cable drums for the PULLMASTER Model PL5 planetary winch can be grooved. Where this option is a requirement, it is necessary to state the size of wire rope which is to be used with the winch.

OPTIONAL GEAR SECTION FOR THE HYDRAULIC MOTOR:

The performance of the standard PULLMASTER Model PL5 planetary winch may be changed by using a different displacement motor.

(See APPENDIX A for performance information.)

HYDRAULIC MOTORS FOR HIGH PRESSURE HYDRAULIC SYSTEMS:

The operating pressure of the PULLMASTER Model PL5 planetary winch with standard hydraulic motor is limited to 2100 psi (145 bar). For hydraulic systems operating with higher hydraulic pressure, the winch can be supplied with a hydraulic piston motor which will provide for the same basic performance in terms of line pull and line speed capacity.

(Contact the factory for this requirement.)

The PULLMASTER WINCH CORPORATION will consider other options for quantity requirements.

SPECIFICATIONS

Performance specifications are based on standard hydraulic motor, gear ratio and cable drum with 7/16 inch diameter wire rope. See APPENDIX A for performance of available options.

CABLE DRUM DIMENSIONS (STANDARD DRUM):

Barrel Diameter	7.38 in	187 mm
Flange Diameter	11.00 in	279 mm
Barrel Length	6.56 in	167 mm

CABLE STORAGE CAPACITY:

Size of wire rope	1/4 in	348 ft	106 m
	5/16 in	218 ft	67 m
	3/8 in	157 ft	48 m
	7/16 in	110 ft	34 m
	1/2 in	100 ft	31 m

MAXIMUM OPERATING PRESSURE: 2100 psi 145 bar

MAXIMUM OPERATING VOLUME: 24 (US) gpm 91 l/min

MINIMUM OPERATING VOLUME: 6 (US) gpm 23 l/min

DRUM TORQUE AT MAXIMUM PRESSURE: 17,578 lb-in 1986 Nm

DRUM RPM AT MAXIMUM VOLUME: 66 rpm

LINE PULL AT MAXIMUM PRESSURE:

Bare drum	4500 lb	20.0 kN
Full drum	3328 lb	14.8 kN

LINE SPEED AT MAXIMUM VOLUME:

Bare drum	135 fpm	41 m/min
Full drum	183 fpm	56 m/min

PERMISSIBLE SYSTEM BACK PRESSURE AT MOTOR RETURN PORT:

65 psi 4.5 bar

PERMISSIBLE PRESSURE

AT BRAKE HOUSING SAFETY VALVE: 100 psi 7 bar

LUBRICATING OIL: Volume required (-1, -2 drum): 0.3 (US) gal (1.1 litre)
Volume required (-6 drum): 0.5 (US) gal (1.9 litre)
Refer to RECOMMENDATIONS for viscosity and instructions.

PERFORMANCE GRAPHS

PG-PL5-C

LINE PULL VS. OIL PRESSURE

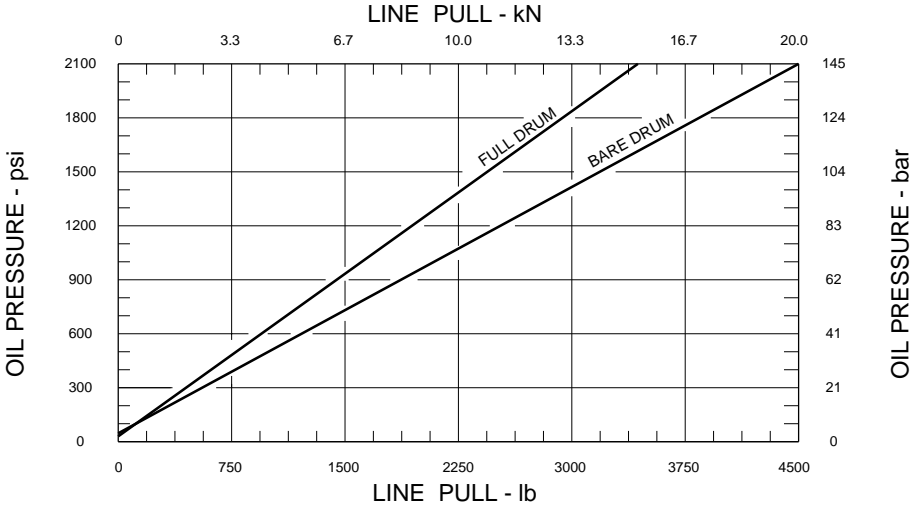

LINE SPEED VS. OIL VOLUME

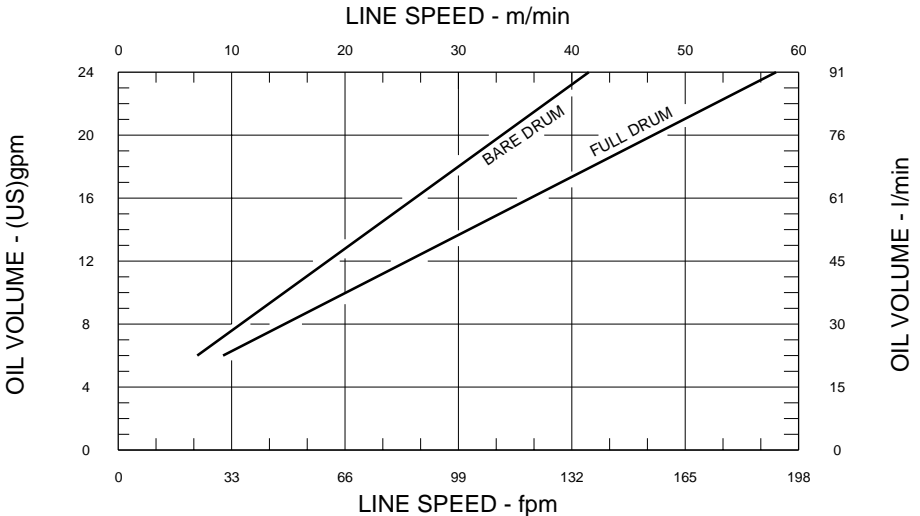

Performance graphs are based on standard hydraulic motor, gear ratio and cable drum with 7/16 inch diameter rope.

TYPICAL HYDRAULIC CIRCUITS

HC-PL5-S1-B

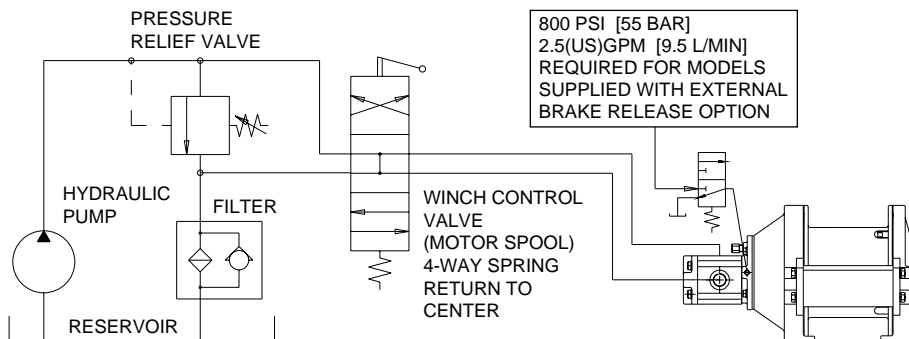

1. TYPICAL HYDRAULIC CIRCUIT - STANDARD CONTROL VALVE

Refer to above hydraulic circuit for installations where the winch is controlled by an individual control valve. Note that the valve must have a **motor spool** (both winch ports open to tank in neutral position). A motor drain line is not required.

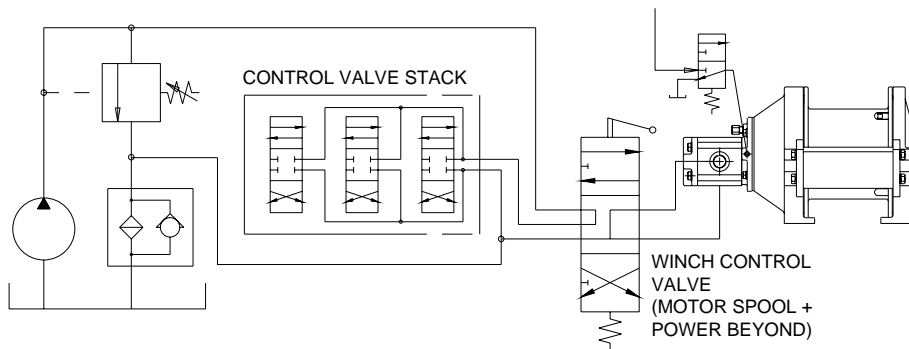

2. TYPICAL HYDRAULIC CIRCUIT - POWER BEYOND CONTROL VALVE

Refer to above hydraulic circuit when the winch control valve is used in a circuit containing stacked valves controlling other functions, as occurs on hydraulic cranes and loaders. The winch control valve must have a **motor spool** and **power beyond** feature. The winch valve is shown upstream of the stacked control valves. If the winch control valve is located downstream of the stacked control valves, the valve stack must have the **power beyond** feature. A motor drain line is not required.

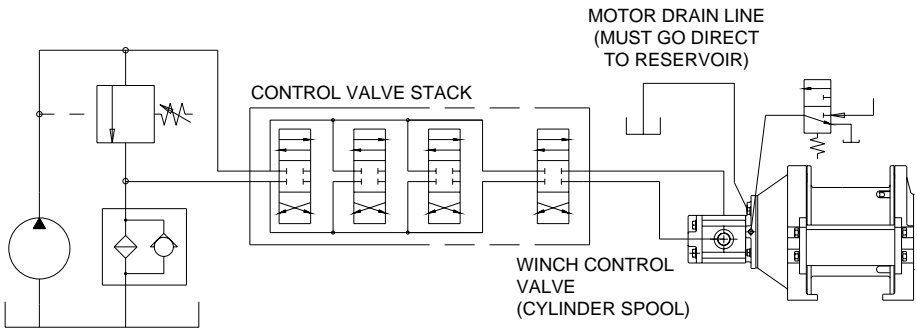

3. TYPICAL HYDRAULIC CIRCUIT - STACKED CONTROL VALVE

Refer to above hydraulic circuit when the winch control valve is one of several stacked control valves and has a **cylinder spool** (winch ports blocked in neutral position). In this configuration, the safety valve must be replaced with a drain line plumbed directly to the reservoir. The drain line cannot be connected to a common return line.

IMPORTANT: For proper function of the winch in any circuit, the return line back pressure measured at the motor return port and the brake housing pressure measured at the safety valve must not exceed pressures per SPECIFICATIONS.

RECOMMENDATIONS

HYDRAULIC FLUID:

The hydraulic fluid selected for use with PULLMASTER planetary winches should be a high grade, petroleum based fluid with rust, oxidation and wear resistance. Fluid cleanliness and operating viscosity are critical to winch reliability, efficiency and service life.

For optimum performance, the recommended viscosity range at operating temperature is 81 - 167 SUS (16 - 36 CS). For extreme operating conditions of short duration, the maximum viscosity range of 58 - 4635 SUS (10 - 1000 CS) should not be exceeded.

For optimum performance, the recommended hydraulic fluid temperature operating range is 80 - 150F (27 - 66C). For extreme operating conditions of short duration, the maximum temperature range of -5 - 180F (-21 - 82C) should not be exceeded.

LUBRICATION:

The winch gear train requires oil bath lubrication. The winch is shipped from the factory without lubricating oil.

IMPORTANT: ADD LUBRICATING OIL UP TO THE LEVEL OF THE END HOUSING OIL FILL PORT BEFORE RUNNING WINCH.

Refer to INSTALLATION DIMENSIONS for location of lubricating oil fill port. Refer to SPECIFICATIONS for quantity of oil required. SAE 90 lubricating oil is recommended. Consult lubricating oil supplier or factory for temperature beyond normal operating range.

HYDRAULIC PUMP:

For maximum performance of the PULLMASTER planetary winch the hydraulic pump must supply the maximum flow of hydraulic fluid at the hydraulic pressure stated in SPECIFICATIONS.

HYDRAULIC CONTROL VALVE:

The standard control valve used for operating PULLMASTER planetary winches must have a four-way, spring return to neutral feature, which provides for open flow from the pressure ports of the winch to the reservoir in neutral position of the control (motor spool). It is important to point out that good speed control, especially when lowering a load, depends on the "metering" characteristics of the control valve. The better the oil flow is "metered", the better will be the speed control.

HYDRAULIC PRESSURE RELIEF:

The hydraulic circuit for the PULLMASTER planetary winch requires a pressure relief set at the operating pressure (see SPECIFICATIONS). Usually, a pressure relief is part of the hydraulic control valve. Where this is not the case, a separate pressure relief valve must be installed and set at the recommended maximum pressure.

HYDRAULIC RESERVOIR:

It is recommended that the hydraulic reservoir has sufficient capacity to provide good heat dissipation in order to prevent over-heating of the hydraulic fluid.

The hydraulic reservoir should be made from clean and scale-free material to prevent contamination of the hydraulic fluid. In order to prevent air from being mixed with the hydraulic fluid, the reservoir should have an over-flow baffle separating the return lines from the suction line and all return lines should enter the reservoir below the fluid level. The reservoir should be mounted close to and above the hydraulic pump in a location which provides for free air circulation around the reservoir.

HYDRAULIC FILTER:

Consult hydraulic component manufacturer for recommendation. Generally, 5 to 10 micron filters are acceptable. In order to prevent accidental stoppage of the return line flow, the filter should have a by-pass feature.

HYDRAULIC HOSES:

The following hydraulic hose with suitable fittings is recommended for the PULLMASTER Model PL5 planetary winch.

Pressure lines: SAE 100R2-14 or better
Motor drain line
(when required): SAE 100R6-6 or better

It is recommended that larger hydraulic hose be installed where drain line or pressure lines are excessively long.

USE OF AN E STOP:

(FOR EUROPEAN MACHINERY DIRECTIVE APPLICATIONS)

The use of an E stop (emergency) is mandatory in the controls circuit. The E stop is to be placed in the operator's control panel. The E stop has to be designed and placed in line with EN 60204 and EN 418.

INSTALLATION INSTRUCTIONS



DANGER

**FAILURE TO FOLLOW INSTALLATION INSTRUCTIONS WILL
RESULT IN PROPERTY DAMAGE, SEVERE INJURY OR DEATH.**

The initial installation or mounting of a PULLMASTER planetary winch is critically important for proper operation and performance. If the winch is mounted to an uneven surface, the centre line of the unit can be distorted to a point where the winch will not operate in either direction. It is therefore very important that the following instructions are observed when a PULLMASTER planetary winch is installed:

- 1) Make certain that the mounting platform is sufficiently strong in order to avoid deflection when a load is lifted.
- 2) Set the winch on the mounting platform and check for surface contact on all mounting pads of the winch.
- 3) If there is a space between the mounting surface and one of the mounting pads, the mounting surface is not even and the space below the mounting pad must be shimmed. If this condition exists, proceed as follows:
 - a) Install mounting bolts snug tight on the three mounting pads which are in contact with the mounting surface. For mounting bolt size and grade, see INSTALLATION DIMENSIONS.
 - b) Measure the space underneath the fourth mounting pad with a feeler gauge and use shim stock of equivalent thickness in the space between the mounting pad and the mounting surface.
 - c) Only after this procedure, should the fourth mounting bolt be installed. Tighten all four bolts as per BOLT TORQUE CHART at back of manual.
- 4) Fill the winch with lubricating oil. Required volume is 0.3 (US) gallon (1.1 litre). Refer to SPECIFICATIONS for -2 and -6 drums. Refer to INSTALLATION DIMENSIONS for location of filler port.
- 5) Use recommended circuit components and hydraulic hoses.
- 6) When required, the winch motor drain line must be connected directly to the reservoir. Do not connect to a common return line.

IMPORTANT: Excessive pressure at brake housing will damage the winch motor or oil seals. Never plug safety valve port.

- 7) Before operating the winch with a load, verify that hydraulic fluid is circulating through the brake assembly by removing the safety valve and checking flow when the winch is run in the lowering direction. Flow should measure 1.5 gpm (6 l/min).

NOTE: The hydraulic pressure to rotate the drum at full speed in reverse direction may vary 250 psi to 500 psi (17 bar to 34 bar) depending on the load and from 500 psi to 1000 psi (34 bar to 69 bar) without load.

To rotate the drum at full speed in forward direction, pressure required may be up to 400 psi (28 bar).

OPERATING INSTRUCTIONS



DANGER

FAILURE TO FOLLOW OPERATING INSTRUCTIONS COULD RESULT IN PROPERTY DAMAGE, SEVERE INJURY OR DEATH.

After the PULLMASTER planetary winch has been installed in accordance with the INSTALLATION INSTRUCTIONS, the wire rope can be fastened to the cable drum.

IMPORTANT: The ropes, chains, slings, etc. are not part of the winch and are not covered by this manual. Refer to manufacturer's handling, inspection and maintenance recommendations to avoid potential accidents. For selection of ropes, etc. please check following product standards: DIN 15020, prEN818-1/9, prEN 1492-1/2, prEN 1677-1/3 and other relevant product standards.

- 1) The cable drum of the PULLMASTER planetary winch has two cable anchor slots, one for clockwise and one for counterclockwise hoisting. Standard rotation for hoisting is counterclockwise when looking at the hydraulic motor of the unit. It is critical to select the cable anchor slot which will permit winding of the wire rope on the drum in the correct direction of rotation. If the wire rope is wound on the cable drum in the wrong direction of rotation, the winch will have no braking capacity. Each winch is shipped from the factory with a label on the drum, indicating the correct cable anchor slot.

WIRE ROPE INSTALLATION

Counterclockwise hoisting winch shown. (Use cable anchor slot on opposite side of drum for clockwise hoisting winch.)

Feed the wire rope through the cable anchor slot. Loop rope back into slot as shown. Insert cable anchor into slot, small end first and long side nearest the drum flange. Pull rope tight to wedge rope in slot.

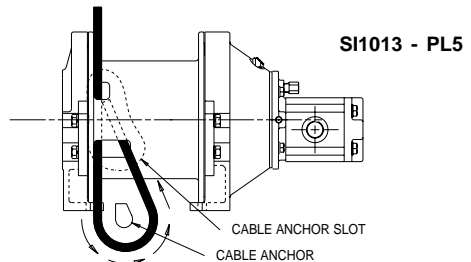

- 2) On wire rope installation, care must be taken that the wire rope is wrapped completely around the cable anchor and properly pulled into the cable anchor slot in the cable drum. The cable drum requires a minimum of 5 wraps of wire rope for safety.
- 3) The winch operation is controlled by a single control valve lever which has a **forward**, a **reverse** and a **neutral** position. Speed control in either direction is obtained by modulation of the control valve lever. Maximum line speed in either direction is obtained when the control valve lever is moved as far as it can go. The disc brake of the winch will come on automatically when the winch control lever is returned to **neutral**.
- 4) Always warm up equipment prior to operating winch, particularly in low ambient temperature. Circulate hydraulic oil through the winch control valve for several minutes to warm the hydraulic systems. To prime the winch with warm oil, operate the winch at slow speed, forward and reverse, several times.
- 5) To ensure proper winch installation and function, raise and lower a full test load to a safe height before using winch for regular operation at the start of each shift.
- 6) Prevent corrosion damage to winch interior. If not used regularly, run winch up and down at least once every two weeks.

If, after a new installation, the winch does not function properly, refer to the TROUBLE SHOOTING section of this manual.

TROUBLE SHOOTING

GENERAL:

In most cases, when the hydraulic winch does not perform satisfactorily, the cause for malfunction is found somewhere in the hydraulic circuit. Before the winch is removed from its mounting and disassembled, all of the hydraulic circuit components should be checked for proper function.

IMPORTANT:

The hydraulic oil volume relates to the line speed or rpm of the winch.

Therefore, if the winch does not produce the specified maximum rated line speed or drum rpm, a loss of hydraulic flow somewhere in the hydraulic circuit can be analysed. If this condition exists, install a flow meter into the hydraulic circuit to check the volume of oil supplied to the pressure port of the hydraulic winch motor when the winch control is completely opened. The flow meter should indicate the maximum operating volume. If this test indicates a loss of hydraulic flow, check the hydraulic pump, the relief valve and the control valve. If the pump is driven by V-belts, check for belt slippage.

The hydraulic pressure relates to the pulling capacity of the winch.

If the winch will not produce the specified maximum line pull, install a pressure gauge in the pressure line leading to the hoisting port on the hydraulic winch motor. Stall the winch to prevent rotation of the drum and then open the control valve. Check the hydraulic pressure reading of the installed pressure gauge. If the pressure reads below the specified maximum operating pressure, look for trouble in the hydraulic pump, the relief valve and the control valve. If the hydraulic pump is driven by V-belts, check for belt slippage. When checking oil pressure and volume in the hydraulic circuit, verify that the hydraulic reservoir is filled to the top level and the hydraulic pump is running at maximum operating rpm.

Only after the hydraulic system has been checked and found to be in order, use the following indications for probable causes of failure in the winch:

FAILURE	PROBABLE CAUSE
<p>Winch will not produce line pull at maximum pressure as listed in SPECIFICATIONS.</p>	<ul style="list-style-type: none"> a) Winch is mounted to an uneven surface. (See INSTALLATION INSTRUCTIONS.) b) Cable sheaves or block purchase operated with the winch are not turning freely. c) Damage or wear in the hydraulic motor. d) The relief valve pressure may be set too low. e) Excessive back pressure in the hydraulic system.
<p>Winch will not produce line speed at maximum volume as listed in SPECIFICATIONS.</p>	<ul style="list-style-type: none"> a) Winch is mounted to an uneven surface. (See INSTALLATION INSTRUCTIONS.) b) Cable sheaves or block purchase operated with the winch are not turning freely. c) Damage or wear in the hydraulic motor. d) Excessive back pressure in the hydraulic system.
<p>Winch will not reverse.</p>	<ul style="list-style-type: none"> a) Leakage out of the brake piston prevents the disc brake from being released against the brake springs. This is caused by damage to the O-rings on the brake piston or connecting tube. b) Insufficient hydraulic pressure. (See SPECIFICATIONS for minimum operating pressure.) c) Winch is mounted to an uneven surface. (See INSTALLATION INSTRUCTIONS.) d) Hydraulic pressure is not reaching the brake piston due to plugged passage.

TROUBLE SHOOTING CONTINUED

FAILURE	PROBABLE CAUSE
<p>Brake will not hold.</p>	<ul style="list-style-type: none"> a) Brake plates or divider plates have been damaged by contamination in the hydraulic fluid or lack of circulation flow in the brake housing. b) Brake piston is seized in the brake housing because of contamination in the hydraulic fluid. c) Excessive back pressure in the return line of the hydraulic system causes the brake to release. d) Control valve has incorrect spool which traps hydraulic pressure in the brake piston when the control valve handle is returned to neutral position. For proper function of the automatic brake, both pressure ports of the winch must be open to the reservoir in neutral position of the control valve. e) Wire rope is fastened to the incorrect cable anchor slot. f) Over-running clutch is damaged or surface where over-running clutch engages on motor drive shaft is worn or indented. g) Winch supplied with external brake release option is not plumbed per TYPICAL HYDRAULIC CIRCUITS. Failure to vent external brake release port to reservoir may trap pressure and cause winch brake to slip.
<p>Brake vibrates when lowering a load.</p>	<ul style="list-style-type: none"> a) Pump does not supply sufficient flow. Pump rpm must be maintained at normal operating speed when a load is lowered. b) Brake is running too hot. This is caused by a complete lack of, or insufficient, circulation flow. c) Control valve for the winch operation has poor metering characteristics. d) Damaged brake plates or divider plates. e) Over-running clutch is damaged or surface where over-running clutch engages on motor drive shaft is worn or indented. f) Air has mixed with hydraulic oil resulting in foamy oil.
<p>Oil leaks.</p>	<ul style="list-style-type: none"> a) Oil leaks from the motor flange are caused by a damaged O-ring seal on the motor flange. b) Oil leaks occurring between the cable drum flanges and housings are caused by excessive pressure in the brake housing. Excessive pressure in the brake housing will damage the oil seal between the brake housing and cable drum interior. c) Oil leaks from the safety valve are caused by the excessive pressure in the brake housing or operation with incorrect hydraulic fluid during cold weather or incorrect spool in the control valve.

Refer to the SERVICE INSTRUCTIONS if it becomes necessary to disassemble the Model PL5 winch.

SERVICE INSTRUCTIONS

GENERAL:

Before disassembling the PULLMASTER Model PL5 planetary winch, read and understand the following instructions.

Replace expendable parts such as O-rings and oil seals when reassembling the winch. Have a winch seal kit (Part No. 23025) on hand before the unit is disassembled. If motor is to be serviced, have on hand motor seal kit (Part No. 24227).

NOTE: Backup washers may be included with seal kit. Install with oil seals as per instructions. If not present in seal kit, the oil seals supplied do not require backup washers.

Disconnect all hydraulic hoses, remove the winch from its mounting and relocate to a clean working area, similar to one used for service work on any other hydraulic component. Special tools are not required to service the winch. Adjustments and calibrations are not required.

All parts, as they are removed from the winch assembly, should be inspected for wear and damage. Worn or damaged parts must be replaced. Thoroughly clean parts before reassembly. Do not use solvent to clean the brake friction plates. During reassembly, lubricate all O-rings and oil seals with grease before installation.

The following SERVICE INSTRUCTIONS refer to part descriptions and item numbers which appear in the group drawings.

DISASSEMBLY

For the majority of required service or repair work, disassembly is required only on the brake housing of the PULLMASTER Model PL5 planetary winch. There are no special tools needed for the service or repair work and no adjustments or calibrations are necessary. Proceed with the disassembly as follows:

REMOVAL OF HYDRAULIC MOTOR ASSEMBLY:

- 1) Before removing hydraulic motor, refer to page 18 drawing # S11043 and tick mark the position of the hydraulic motor to facilitate reassembly.
- 2) Remove four capscrews, item 931, and lockwashers, item 933, from the motor adaptor, item 900. Brake springs, item 752, apply pressure against inside of motor adaptor, therefore it is recommended that capscrews are unscrewed, one turn at a time, until spring pressure has been released. The complete motor assembly, including motor adaptor, can now be removed from brake housing assembly.
- 3) Remove and discard two O-rings, item 801 and item 707. (O-ring, item 801, seals pressure transfer hole for automatic brake release and is situated on flange of brake housing.)

DISASSEMBLY OF HYDRAULIC MOTOR ASSEMBLY:

If service or repair work requires access to interior of brake housing, hydraulic motor should not be disassembled. If problem has been analysed to be in hydraulic motor, proceed with disassembly as follows:

- 1) Remove four hex capscrews, item 951, together with lockwashers, item 953, from motor assembly.

IMPORTANT: Failure to exercise care when removing motor port end cover or gear housing could permanently damage machined surfaces of motor components. Take care not to damage machined surfaces of motor components at disassembly.

- 2) Remove port end cover, item 871, from gear housing, item 860.
- 3) Remove gear set, item 881, item 882 and thrust blocks, item 885.
- 4) Remove and discard channel seals, item 887, item 888 and backup seals, item 897.
- 5) Carefully pry gear housing, item 860, off of motor adaptor, item 900. Dowel pins, item 865, may stay in gear housing.
- 6) Discard section seals, item 869.

Section seals, channel seals and backup seals in hydraulic motor assembly are not part of winch seal kit. Seal kit for hydraulic motor can be ordered from factory under Part No. 24227.

SERVICE INSTRUCTIONS CONTINUED

DISASSEMBLY OF BRAKE HOUSING ASSEMBLY:

Disassemble brake housing assembly as follows:

- 1) Remove ten brake springs, item 752. Examine springs for damage and measure overall length. Overall spring length should be 1.25 inch. Springs measuring less than 1.19 inch should be replaced.
- 2) Pull brake piston, item 750, out of brake housing, item 700.
- 3) Remove and discard O-rings, item 751 and 753.
- 4) Thoroughly inspect brake piston outer diameters and brake housing inner bores for scoring caused by hydraulic fluid contamination. Minor surface damage may be repaired by polishing with a fine emery cloth.
- 5) Remove circlip, item 727, from primary sungear, item 440. Remove brake hub, item 720, sprag clutch, item 723, and sprag clutch aligners, item 722, from primary sungear.



DANGER

DAMAGED FRICTION OR DIVIDER PLATES WILL REDUCE BRAKING CAPACITY AND ALLOW THE LOAD TO DROP, CAUSING PROPERTY DAMAGE, SEVERE INJURY OR DEATH. SOLVENT MAY DAMAGE THE FRICTION PLATES. DO NOT USE SOLVENT TO CLEAN THE FRICTION PLATES. PERFORM THOROUGH INSPECTION AND IF NECESSARY, REPLACE FRICTION AND DIVIDER PLATES AS A SET.

- 6) Remove five friction plates, item 716, and six divider plates, item 713, and inspect for damage or wear. Plates should be flat and smooth. Plates should not show heat discoloration. Paper material on friction plates should be intact and grooved. If any damage is detected, replace friction and divider plates as a set (winches may contain optional metallic friction plates).
- 7) Remove brake spacer, item 712.

DISASSEMBLY OF PRIMARY DRIVE:

If the primary drive requires service or repair, disassemble as follows:

- 1) Remove pipe plug, item 503, from cable drum, item 500, to drain lubricating oil from the winch interior.
- 2) Remove eight capscrews, item 555, and lockwashers, item 553. Remove two tie bars, item 556. Stand winch upright on its end housing.
- 3) Remove six capscrews, item 537, and lockwashers, item 541, through access opening in brake housing. Lift brake housing with bearing flange out of cable drum, item 500 (bearing flange may stay in the cable drum). Remove and discard O-ring, item 539.
- 4) Remove circlip, item 719, from primary sungear, item 440.
- 5) Remove primary sungear, item 440, from brake housing, item 700.



DANGER

MINOR SURFACE DEFECTS WHERE THE OVER-RUNNING CLUTCH ENGAGES THE MOTOR DRIVE SHAFT WILL RESULT IN BRAKE FAILURE AND ALLOW THE LOAD TO DROP, CAUSING PROPERTY DAMAGE, SEVERE INJURY OR DEATH. THOROUGHLY INSPECT THIS AREA AND, IF NECESSARY, REPLACE PRIMARY SUNGEAR, SPRAG CLUTCH AND BRAKE HUB ASSEMBLY AS A SET.

- 6) Thoroughly inspect primary sungear, item 440, and brake hub, item 720, particularly surfaces where sprag clutch, item 723, engages.
- 7) If any indentation or surface damage is detected, replace brake hub, sprag clutch and primary sungear as a set.
- 8) Remove two thrust washers, item 737, and thrust bearing, item 739. Inspect parts and replace if damaged.
- 9) Remove and discard oil seal, item 711, and backup washer, item 710.
- 10) Remove primary planet hub assembly with final sungear, item 340, from cable drum.

SERVICE INSTRUCTIONS CONTINUED

- 11) Inspect planet hub stopper, item 402, for damage or wear and replace if less than .09 inch thick.
- 12) Inspect three primary planet gears, item 420, for damage or wear. If it is necessary to remove planet gears, remove circlip, item 411, and press planet pin, item 410, out of planet hub, item 400. Inspect needle bearing, item 423, and two thrust washers, item 421, and replace if damaged or worn.
- 13) Remove final sungear, item 340, with circlip, item 341, and sungear stopper, item 344. Inspect stopper for damage or wear. If stopper is worn more than .03 inch below face of sungear, stopper should be replaced.
- 14) Inspect planet hub stopper, item 704, for damage or wear and replace if less than .09 inch thick.
- 15) Pull bearing flange, item 530, and ball bearing, item 533, off of brake housing.
- 16) Remove circlip, item 535. Push ball bearing, item 533, out of bearing flange. Inspect and replace if damaged.
- 17) Remove and discard oil seal, item 531.

DISASSEMBLY OF FINAL DRIVE:

If final drive requires service or repair, disassemble as follows:

- 1) Remove final planet hub assembly from cable drum.
- 2) Inspect three final planet gears, item 320, for damage or wear. If it is necessary to remove planet gears, remove circlip, item 311, and press planet pin, item 310, out of final planet hub, item 300. Inspect 20 loose rollers, item 323, and two thrust washers, item 321, and replace if damaged.

Winches with optional -6 drum only:

- 2a) Remove coupling, item 520, from end housing spline.
- 3) Remove end housing, item 100, out of cable drum ball bearing, item 507.
- 4) Remove circlip, item 513. Push ball bearing, item 507, out of cable drum. Inspect and replace if damaged.
- 5) Remove and discard oil seal, item 505.
- 6) Inspect cable drum gear teeth for damage or wear.

REASSEMBLY

Thoroughly clean all parts. Use only new, well-greased O-rings and oil seals. Unless otherwise specified, torque fasteners per BOLT TORQUE CHART at back of manual.

REASSEMBLY OF FINAL DRIVE:

Reassemble final drive by reversing the disassembly procedure.

- 1) Press new, well-greased oil seal, item 505, into cable drum, item 500.
- 2) Press ball bearing, item 507, into cable drum and secure with circlip, item 513.
- 3) Insert end housing, item 100, into cable drum ball bearing, item 507.

Winches with optional -6 drum only:

- 3a) Engage coupling, item 520, onto end housing.
- 4) Reassemble final planet hub assembly. Use grease to temporarily hold 20 loose rollers, item 323, in bore of planet gear, item 320. Position thrust washers, item 321, on either side of planet gear and press planet pin, item 310, into final planet hub, item 300. Retain with circlip, item 311.
- 5) Insert final planet hub assembly into cable drum. Ensure that planet hub spline is fully engaged.

REASSEMBLY OF PRIMARY DRIVE:

Reassemble primary drive by reversing the disassembly procedure.

- 1) Press new, well-greased oil seal, item 531, into bearing flange, item 530. Press ball bearing, item 533, into bearing flange and secure with circlip, item 535.
- 2) Verify planet hub stopper, item 704, is installed on brake housing hub.
- 3) Verify sungear stopper, item 344, and circlip, item 341, are installed on final sungear, item 340.

SERVICE INSTRUCTIONS CONTINUED

- 4) Install final sungear into primary planet hub, item 400.
- 5) Reassemble primary planet hub assembly. Press needle bearing, item 423, into planet gear, item 420. Position thrust washer, item 421, on either side of planet gear and press planet pin, item 410, into primary planet hub, item 400. Retain with circlip, item 411.
- 6) Verify planet hub stopper, item 402, is installed on planet hub.
- 7) Insert primary planet hub assembly into cable drum. Ensure that final sungear, item 340, is fully engaged with final planet gears, item 320.
- 8) Press new, well-greased oil seal, item 711, and backup washer, item 710, into brake housing bore, item 700.
- 9) Install thrust bearing, item 739, (with thrust washer, item 737, on either side) against oil seal, item 711.
- 10) Insert primary sungear, item 440, through brake housing bore, item 700, and fasten with circlip, item 719.
- 11) Install new, well-greased O-ring, item 539, onto bearing flange, item 530. Insert bearing flange into cable drum opening and fasten with six capscrews, item 537, and lockwashers, item 541. Slide brake housing, item 700, into bearing flange, turning primary sungear, item 440, to engage primary planet gears, item 420.
- 12) Use eight capscrews, item 555, and lockwashers, item 553, to secure tie bars, item 556.
- 13) Install pipe plug, item 503, into cable drum.

REASSEMBLY OF BRAKE HOUSING ASSEMBLY:

Reassemble brake housing assembly by reversing the disassembly procedure.

- 1) Install sprag clutch, item 723, into bore of brake hub, item 720, and position sprag clutch aligners, item 722, on either side of brake hub. Carefully slide brake hub assembly onto primary sungear, item 440. Secure with circlip, item 727.

IMPORTANT: For proper brake function, verify that brake hub rotation is correct. When viewed from the motor end, the primary sungear of a counterclockwise hoisting winch must turn freely clockwise and lock in the counterclockwise direction.



DANGER

INCORRECT ASSEMBLY OF THE FRICTION PLATE AND DIVIDER PLATE STACK WILL REDUCE BRAKING CAPACITY AND ALLOW THE LOAD TO DROP, CAUSING PROPERTY DAMAGE, SEVERE INJURY OR DEATH. REASSEMBLE PER INSTRUCTIONS.

- 2) Install brake spacer, item 712, into brake housing, item 700.

NOTE: For PL5 with - 213 motor: Refer to 3a)

- 3) Starting and finishing with a divider plate, alternately install six divider plates, item 713, and five friction plates, item 716.
- 3a) Starting with two divider plates, item 713, two friction plates, item 716, repeat two divider plates, two friction plates, one divider plate, one friction plate ending with one divider plate, item 713.
- 4) Install new, well-greased O-rings, items 751 and 753, into piston, item 750. Carefully install brake piston in brake housing, item 700.
- 5) Install ten brake springs, item 752.

REASSEMBLY OF HYDRAULIC MOTOR:

If the hydraulic motor was disassembled, the following procedure should be followed for reassembly:

- 1) Clean all parts thoroughly before reassembly and apply grease liberally to all seals. Use only new seals (seal kit Part No. 24227) for hydraulic motor.
- 2) Install new, well-greased rubber channel seal, item 887 and item 888, into thrust block, item 885, so that protrusions in seal match recesses in block. Install new backup seal, item 897, over top of channel seal, leaving flat side of backup seal flush with surface of thrust block. Insert thrust block, item 885, into the gear housing, making sure seals are facing away from gear set.

SERVICE INSTRUCTIONS CONTINUED

- 3) Install well-greased section seal, item 869, on gear housing, item 860. Install gear housing together with seal section, onto motor adaptor, item 900, lined up on two dowel pins. Tap on tight using a soft headed hammer.
- 4) Install gear set, item 881 and item 882, in gear housing. (External spline end of gear goes into bore of motor adaptor.)
- 5) Insert other thrust block, complete with backup and channel seals, making sure seals are facing away from gear set. Install a well-greased seal section, item 869, on gear housing.
- 6) Install port end cover, item 870, onto gear housing and lightly torque four hex capscrews, item 951, and lockwashers, item 953, to approximately 10 ft-lb (14 Nm).

REPLACE HYDRAULIC MOTOR ASSEMBLY:

- 1) Install new O-ring, item 707, onto motor adaptor pilot. Use grease to temporarily hold two O-rings, item 801, into recesses on flange of motor adaptor, item 900.
- 2) Position motor assembly with brake release pressure transfer holes of motor adaptor and brake housing aligned, as per drawing # S11043 below. Tighten four capscrews, item 931, and lockwashers, item 933, one turn at a time to evenly compress springs.

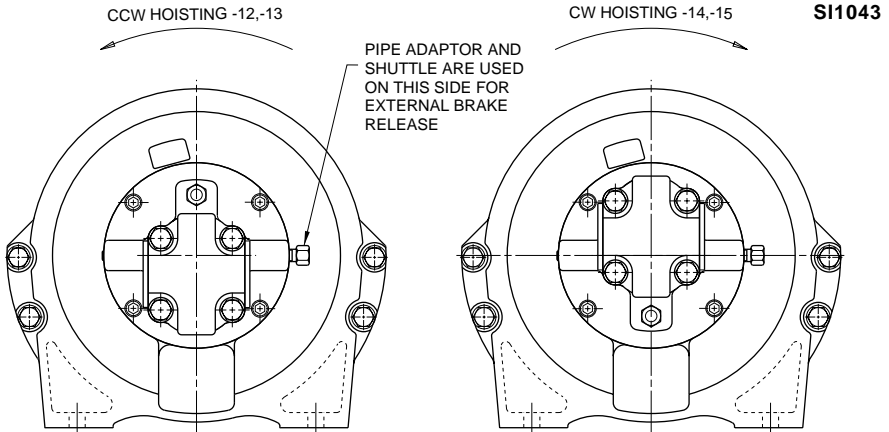

- 3) Plumb winch assembly to a hydraulic supply and torque motor capscrews according to following procedure:
 - Ensure that circulation supply flow is being supplied to the brake housing.
 - Run the winch, with no load, in the hoisting direction at reduced speed (approximately 30% of maximum hydraulic volume).
 - With winch running, evenly tighten four capscrews, item 951, to 45 ft-lb (61 Nm).
 - Test motor operation by running winch at full speed in both directions.

IMPORTANT: Before operating the winch, add lubricating oil up to the level of the end housing oil fill port. Refer to INSTALLATION INSTRUCTIONS for location of fill port. Required volume of oil is 0.3 (US) gallon (1.1 litre) for -1 and -2 drum, 0.5 (US) gallon (1.9 litre) for -6 drum. To ensure proper reassembly, run the winch in both directions without load.



DANGER

LIFTING A LOAD WITH A NEWLY SERVICED WINCH WILL ENABLE AN INSTALLATION OR SERVICE PROBLEM TO GO UNDETECTED AND ALLOW THE LOAD TO DROP, CAUSING PROPERTY DAMAGE, SEVERE INJURY OR DEATH. TO ENSURE PROPER REINSTALLATION, REFER TO PROCEDURES AND TESTS DESCRIBED IN "INSTALLATION" AND "OPERATING INSTRUCTIONS".

RECOMMENDED MAINTENANCE

Winch gear train lubricating oil should be changed after the initial six months or 50 hours of operation, whichever comes first. Lubricating oil should then be changed every 12 months or 500 operating hours, whichever comes first.

Hydraulic system fluid should be changed at least once every 12 months.

For optimum performance over an extended period of time, the following preventive maintenance service should be done every 12 months or 500 operating hours, whichever comes first:

- 1) Disconnect all hydraulic hoses and remove the winch from its mounting.
- 2) Disassemble the winch as per instructions.
- 3) Discard and replace all O-rings and oil seals.
- 4) Clean all parts and inspect for wear and damage as per instructions. Replace worn or damaged parts as required.
- 5) Reassemble the winch as per instructions.
- 6) Follow **INSTALLATION** and **OPERATING INSTRUCTIONS** when returning winch to its mounting.

When ordering parts for the PULLMASTER Model PL5 planetary winch, always quote the complete model number, serial number and specification (spec) number (if applicable) of the unit.

MODEL # _____
SERIAL # _____
SPEC # _____

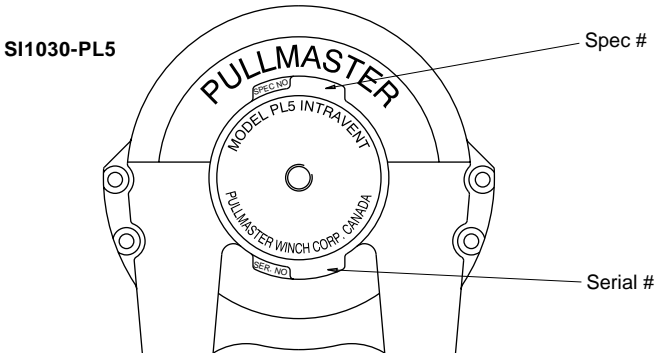

PULLMASTER WINCH CORPORATION reserves the right to change specifications and the design of PULLMASTER planetary winches at any time without prior notice and without incurring any obligations.

ASSEMBLY DRAWING

G1153 & G1283

NOTE: For brake stack-up with -213 motor refer to BRAKE GROUP on PAGE 24.

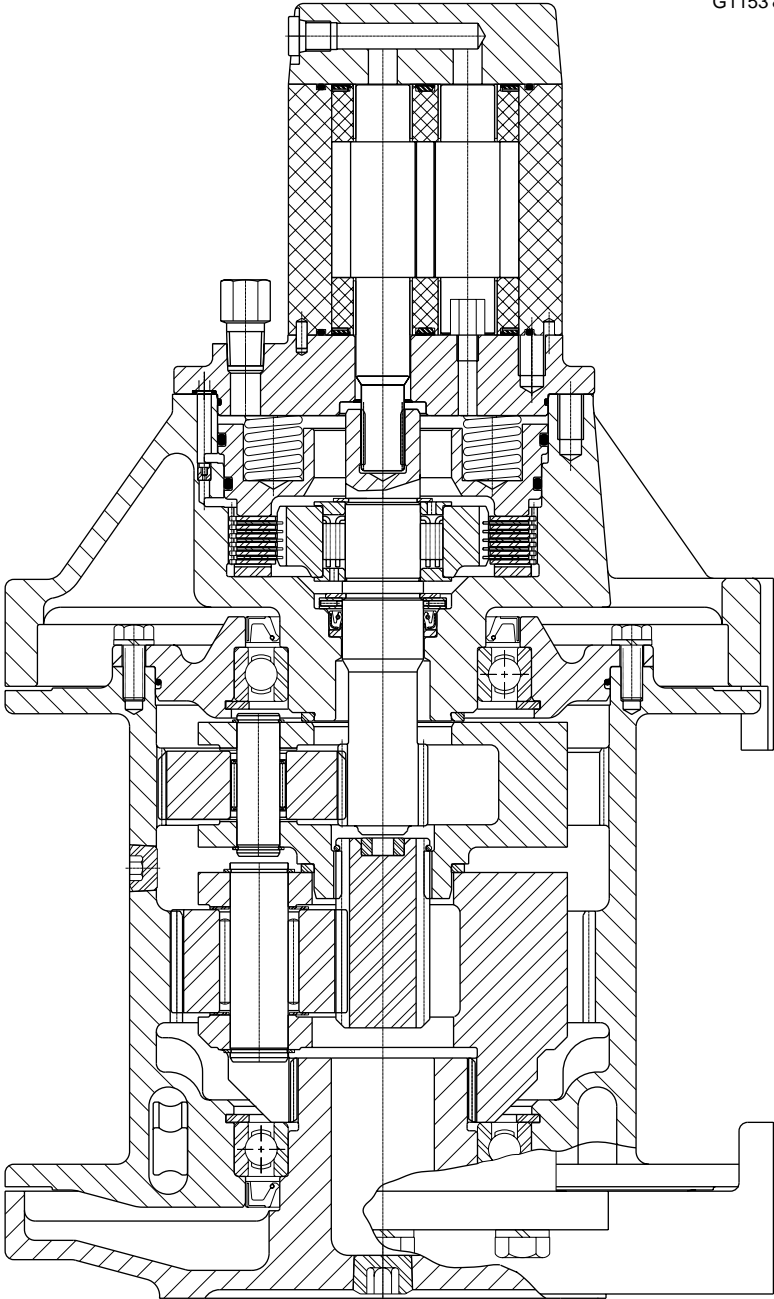

PARTS REFERENCE - DRUM GROUP

ITEM NO.	QTY.	PART NO.	DESCRIPTION
100	1	*	END HOUSING
101	1	25237	PIPE PLUG 3/4 - 14 NPT▲
300	1	20367	PLANET HUB
310	3	20369	PLANET PIN
311	3	25091	CIRCLIP ROTOR CLIP SH-87
313	3	25091	CIRCLIP ROTOR CLIP SH-87
320	3	20370	PLANET GEAR
321	6	25068	THRUST WASHER TORRINGTON # TRA 1423
323	60	25270	LOOSE ROLLER 5/32 X 1.25 TOR. #E151-Q
340	1	20366	SUNGEAR
341	1	25273	CIRCLIP ANDERTON # A1000-137
344	1	20082	SUNGEAR STOPPER
400	1	***	PLANET HUB
402	1	20372	PLANET HUB STOPPER
410	3	***	PLANET PIN
411	6	25119	CIRCLIP ROTOR CLIP SH-62
420	3	***	PLANET GEAR
421	6	25064	THRUST WASHER TORRINGTON # TRA 1018
423	3	25063	NEEDLE BEARING TORRINGTON # B1012
500	1	*	CABLE DRUM
502	1	20085	CABLE ANCHOR
503	1	25085	PIPE PLUG 3/8 - 18 NPT
505	1	25008	OIL SEAL
507	1	25007	BALL BEARING #6014
511	1	*	SET SCREW 5/16 - 18NC X 7/16
513	1	25006	CIRCLIP ROTOR CLIP HO-433
520	1	*	COUPLING
530	1	20363	BEARING FLANGE
531	1	25008	OIL SEAL
533	1	25007	BALL BEARING #6014
535	1	25006	CIRCLIP ROTOR CLIP HO-433
537	6	25171	CAPSCREW - HEX HEAD 5/16 - 18 NC X 7/8 GRADE 5
539	1	25276	O-RING - 164 6 1/4" ID 3/32" CS
541	6	25025	LOCKWASHER 5/16"
553	8	25328	LOCKWASHER 7/16"
555	8	25265	CAPSCREW - HEX HEAD 7/16 - 14 NC X 1.25 GRADE 5
556	2	*	TIE BAR
		*	These parts vary. Refer to APPENDIX B.
		***	These parts vary. Refer to APPENDIX B.
		▲	Before Serial #79792 item 101 was part #25032

DRUM GROUP

DESIGN REVISION EFFECTIVE FROM SERIAL # 75036

G1153

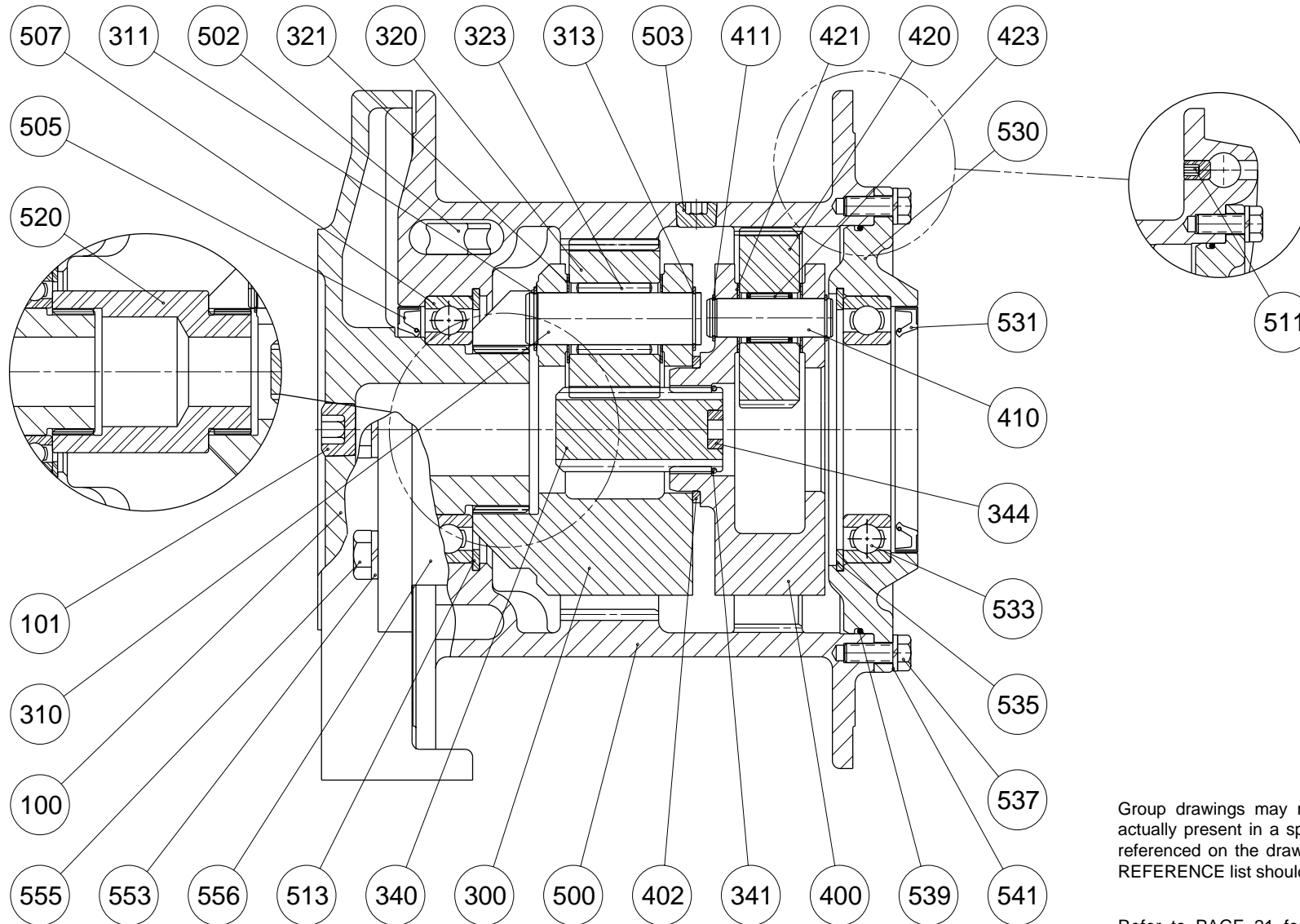

Group drawings may reference more parts than are actually present in a specific assembly. Parts that are referenced on the drawing but are not on the PARTS REFERENCE list should be ignored.

Refer to PAGE 21 for ASSEMBLY DRAWING and PAGE 25 for winch seal kit.

BRAKE GROUP

DESIGN REVISION EFFECTIVE FROM SERIAL # 75036

G1283

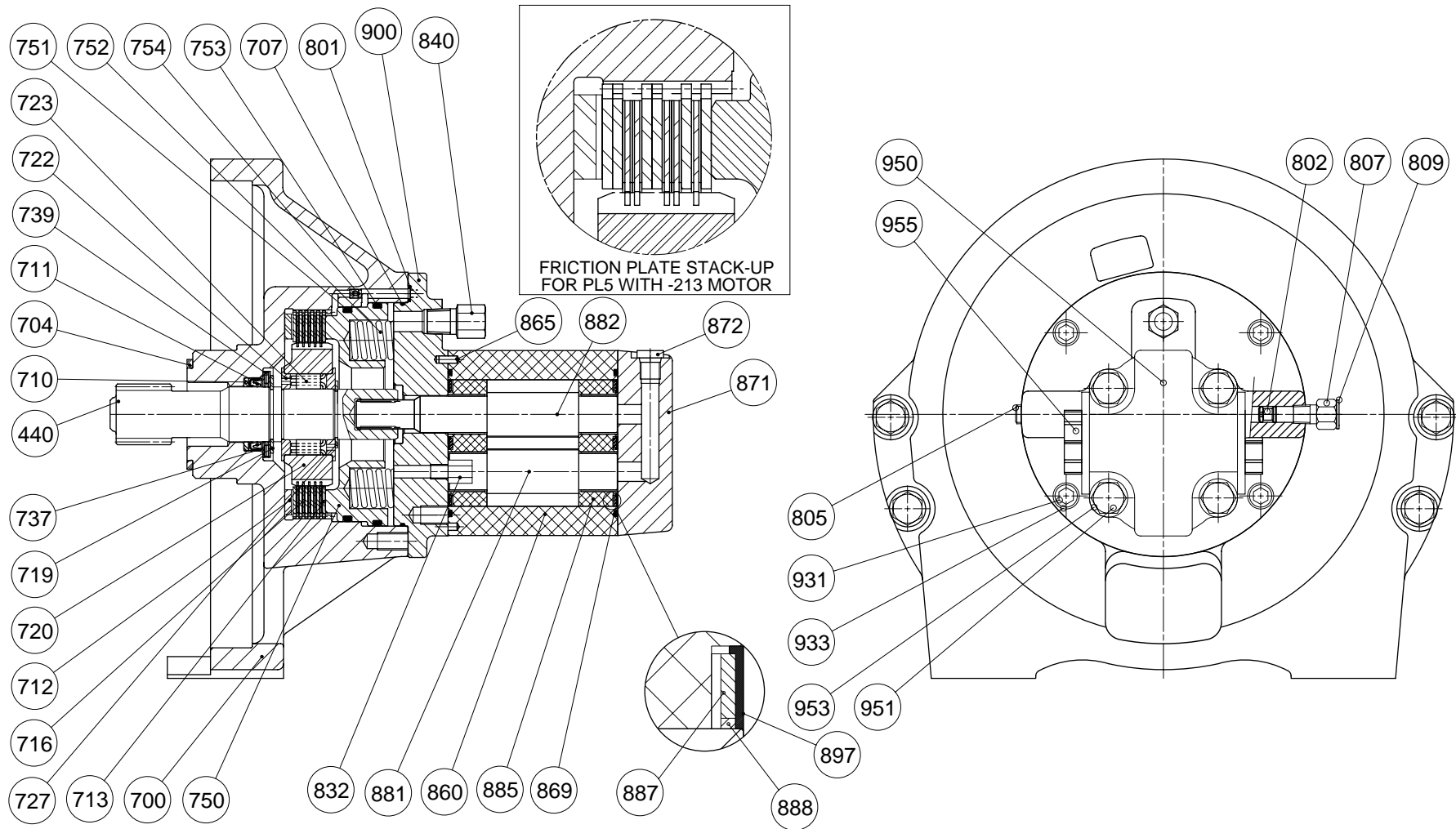

Refer to PAGE 21 for ASSEMBLY DRAWING and PAGE 25 for winch seal kit.

Group drawings may reference more parts than are actually present in a specific assembly. Parts that are referenced on the drawing but are not on the PARTS REFERENCE list should be ignored.

PARTS REFERENCE - BRAKE GROUP

ITEM NO.	QTY.	PART NO.	DESCRIPTION
440	1	***	SUNGEAR
700	1	**	BRAKE HOUSING
704	1	20372	PLANET HUB STOPPER
707	1	25015	O-RING -047 4 1/2" ID 1/16" CS
710	1	20714	BACK UP WASHER FOR OIL SEAL #25278
711	1	25278	OIL SEAL
712	1	21902	BRAKE SPACER
713	6	25024	DIVIDER PLATE
716	5	20034	FRICITION PLATE (OPTIONAL - METALLIC PLATES # 26362)
719	1	25539	CIRCLIP ROTOR CLIP SE-118
720	1	22881	BRAKE HUB
722	2	20183	SPRAG CLUTCH ALIGNER
723	1	25187	SPRAG CLUTCH
727	1	25492	CIRCLIP ROTOR CLIP SH-106
737	2	25483	THRUST WASHER INA # AS 3047
739	1	25537	THRUST BEARING INA # AXK 3047
750	1	23034	PISTON
751	1	25528	O-RING -245 4 3/8" ID 1/8" CS 90 DUROMETER
752	10	20340	BRAKE SPRING
753	1	25261	O-RING -246 4 1/2" ID 1/8" CS 90 DUROMETER
754	1	23044	ORIFICE PLUG
801	2	25792	O-RING -009 7/32" ID 1/16" CS
802	1	*	SHUTTLE
805	1	25040	PIPE PLUG 1/8 - 27 NPT
807	1	*	*
832	2	26785	CHECK VALVE
840	1	20870	SAFETY VALVE
860	1	**	GEAR HOUSING
865	2	26371	DOWEL PIN
869	2	26787	SECTION SEAL
871	1	26378	PORT END COVER
872	1	26379	PLUG - ORB #4
881	1	**	GEAR DRIVEN
882	1	**	GEAR DRIVE
885	4	26788	THRUST BLOCK
887	4	26789	CHANNEL SEAL
888	4	26790	CHANNEL SEAL
897	2	26786	BACKUP SEAL
900	1	24154	MOTOR ADAPTOR
931	4	25772	CAPSCREW
933	4	25298	LOCKWASHER 3/8" HIGH COLLAR
950	1	*	MOTOR
951	4	**	CAPSCREW - HEX HEAD
953	4	26369	WASHER
955	2	25536	PLASTIC CAPLUG 1.0625" -12 THREADED
		23025	WINCH SEAL KIT, CONSISTING OF ITEMS: 505, 531, 539, 707, 710, 711, 751, 753 AND 801.
		24227	MOTOR SEAL KIT, CONSISTING OF ITEMS: 869, 887, 888 AND 897.
			ITEM 950, MOTOR SUB-ASSY CONSISTS OF ITEMS: 900, 802, 805, 807, 809, 832, 860, 865, 869, 871, 872, 881, 885, 887, 888, 897, 951 AND 953.

* These parts vary.
Refer to BRAKE CODE CHART below.
** Refer to APPENDIX B. (Motor Parts)
*** Refer to APPENDIX B. (Reduction Ratio)

BRAKE CODE CHART

BRAKE CODE

ITEM NO.	PART DESCRIPTION	-12	-13	-14	-15
		PART NUMBERS			
802	SHUTTLE	N/A	20849	20849	N/A
807	PIPE PLUG 1/8 - 27 NPT	25040	N/A	N/A	25040
807	PIPE ADAPTOR 1/8 - 27 NPT	N/A	25622	25622	N/A
809	CAPLUG 1/8 NPT	N/A	25374	25374	N/A
950	MOTOR -210 (33cc)	24146	24210	24210	24146
950	MOTOR -211 (27cc)	24147	24211	24211	24147
950	MOTOR -212 (23cc)	24148	24212	24212	24148
950	MOTOR -213 (14cc)	24149	24213	24213	24149

APPENDIX A

PERFORMANCE DATA

Model Number	Hydraulic Requirement		Drum Torque	Drum RPM	Bare Drum		Full Drum	
	Flow	Pressure			Line Pull	Line Speed	Line Pull	Line Speed
PL5-12-210-1	24 (US) gpm 91 l/min	2100 psi 145 bar	17,578 lb-in 1986 Nm	66	4500 lb 20.0 kN	135 fpm 41 m/min	3328 lb 14.8 kN	183 fpm 56 m/min
PL5-12-210-2	24 (US) gpm 91 l/min	2100 psi 145 bar	17,578 lb-in 1986 Nm	66	4500 lb 20.0 kN	135 fpm 41 m/min	2945 lb 13.1 kN	206 fpm 63 m/min
PL5-12-211-1	11 (US) gpm 42 l/min	2250 psi 155 bar	15,625 lb-in 1765 Nm	35	4000 lb 17.8 kN	72 fpm 22 m/min	3098 lb 13.8 kN	92 fpm 63 m/min
PL5-12-211-2	11 (US) gpm 42 l/min	2250 psi 155 bar	15,625 lb-in 1765 Nm	35	4000 lb 17.8 kN	72 fpm 22 m/min	2695 lb 12.0 kN	106 fpm 32 m/min
PL5A-12-212-1	11 (US) gpm 42 l/min	2400 psi 165 bar	19,532 lb-in 2207 Nm	29.5	5000 lb 22.2 kN	60 fpm 18 m/min	3698 lb 16.4 kN	82 fpm 25 m/min
PL5A-12-212-2	11 (US) gpm 42 l/min	2400 psi 165 bar	19,532 lb-in 2207 Nm	29.5	5000 lb 22.2 kN	60 fpm 18 m/min	3272 lb 14.6 kN	92 fpm 28 m/min
PL5-12-213-1	11 (US) gpm 42 l/min	2250 psi 155 bar	7,813 lb-in 883 Nm	69	2000 lb 8.9 kN	142 fpm 43 m/min	1479 lb 6.6 kN	191 fpm 58 m/min
PL5-12-213-2	11 (US) gpm 42 l/min	2250 psi 155 bar	7,813 lb-in 883 Nm	69	2000 lb 8.9 kN	142 fpm 43 m/min	1309 lb 5.8 kN	216 fpm 66 m/min

CABLE STORAGE

DRUM CODE	BARREL DIAMETER	FLANGE DIAMETER	LENGTH	WIRE ROPE DIAMETER						
				1/8"	3/16"	1/4"	5/16"	3/8"	7/16"	1/2"
-2	7.38" 187 mm	12.38" 314 mm	6.56" 167 mm	2146 ft 654 m	975 ft 297 m	510 ft 155 m	354 ft 108 m	234 ft 71 m	177 ft 54 m	130 ft 40 m
-6	7.38" 187 mm	11.00" 279 mm	10.00" 254 mm	2106 ft 642 m	1022 ft 311 m	531 ft 162 m	333 ft 101 m	239 ft 73 m	168 ft 51 m	153 ft 47 m

Performance specifications are based on 7/16 inch diameter wire rope.

Performance data (line pull and line speed) for models with -6 drum is same as equivalent model with -1 drum.

APPENDIX B

WINCH PARTS

DRUM CODE	100	500	511	520	556	700
	END HOUSING	CABLE DRUM	SET SCREW	COUPLING	TIE BAR	BRAKE HOUSING
-1	23026	20361	-	-	23042	23033
-2	23077	22299	-	-	23042	23075
-6	23026	22123	25526	21745	23076	23033

MOTOR PARTS

MOTOR CODE	ITEM			
	860	881	882	951
	GEAR HOUSING	GEAR DRIVEN	GEAR DRIVE	CAPSCREW HEX HEAD
-210	26793	26791	26792	26370
-211	26797	26795	26796	26794
-212	26798	26799	26800	26801
-213	26802	26803	26804	26399

REDUCTION RATIO PART NUMBERS

	400	410	420	440
	PLANET HUB	PLANET PIN	PLANET GEAR	SUNGEAR
STANDARD	23022	20776	23023	23028
"A"	20373	20080	20371	23078

BOLT TORQUE CHART

BOLT DIAMETER Inches	TORQUE Lb-Ft	TORQUE Nm
1/4	9	12
5/16	18	24
3/8	32	43
7/16	50	68
1/2	75	102
9/16	110	149
5/8	150	203
3/4	265	359
7/8	420	569
1	640	868
1 1/8	800	1085
1 1/4	1000	1356
1 3/8	1200	1627
1 1/2	1500	2034

NOTE: Unless otherwise specified, torque bolts per above chart.

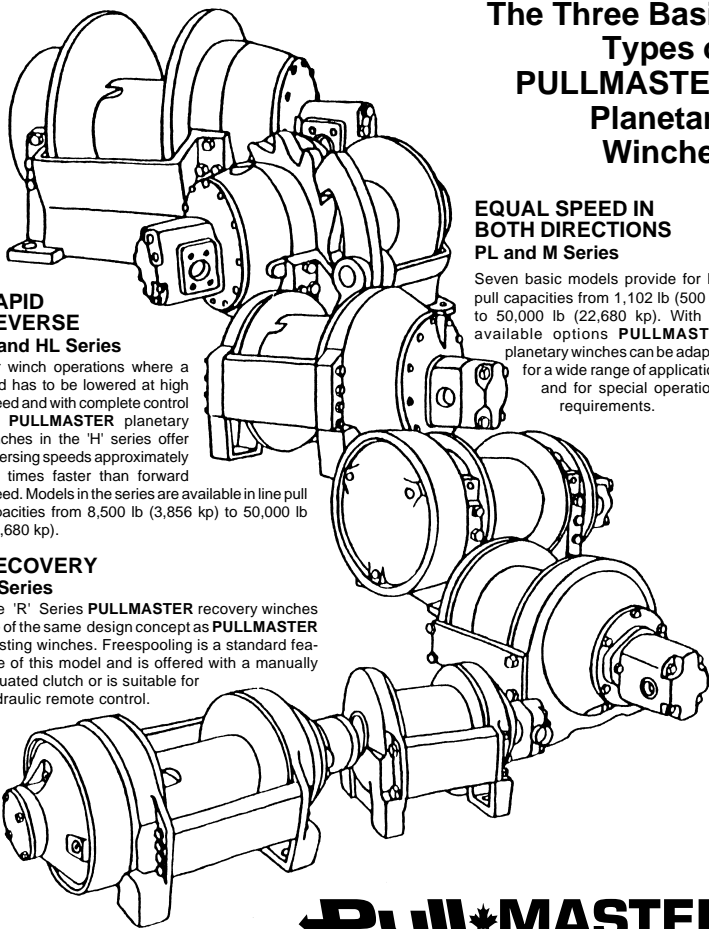

The Three Basic Types of PULLMASTER Planetary Winches

RAPID REVERSE H and HL Series

For winch operations where a load has to be lowered at high speed and with complete control the **PULLMASTER** planetary winches in the 'H' series offer reversing speeds approximately 4.5 times faster than forward speed. Models in the series are available in line pull capacities from 8,500 lb (3,856 kp) to 50,000 lb (22,680 kp).

RECOVERY R Series

The 'R' Series **PULLMASTER** recovery winches are of the same design concept as **PULLMASTER** hoisting winches. Freespooling is a standard feature of this model and is offered with a manually actuated clutch or is suitable for hydraulic remote control.

EQUAL SPEED IN BOTH DIRECTIONS PL and M Series

Seven basic models provide for line pull capacities from 1,102 lb (500 kp) to 50,000 lb (22,680 kp). With the available options **PULLMASTER** planetary winches can be adapted for a wide range of applications and for special operational requirements.

PULLMASTER

A **DOVER** COMPANY

Service for **PULLMASTER** planetary winches can be obtained through a world wide network of **PULLMASTER** distributors. For the distributor nearest to you contact the factory.

Use only authentic **PULLMASTER** replacement parts in the repair of a **PULLMASTER** Planetary winch.

Purchased items such as bearings, seals, O-rings, etc., can be supplied from the factory. However, a cross reference list for such parts is shown in the **PARTS REFERENCE** of this manual.

When in doubt about proper function, installation or repair of a **PULLMASTER** planetary winch please contact your nearest **PULLMASTER** Distributor or the factory.



POWER to Move the World™

TWG Canada

LANTEC and Pullmaster Brands

19350 - 22nd Ave • Surrey, BC V3S 3S6

Voice: + 1 604-547-2100 • Fax: + 1 604-547-2147 • www.team-twg.com

A **DOVER** COMPANY

PMC365

REV.120612