

# CENTIPEDS

## Operation, Maintenance and Service Manual

Complete with Illustrated Parts Lists

## Notice Regarding Non-Atari Parts



Atari, Inc.'s warranty (printed on the inside back cover of this manual) may be voided, if you do any of the following:

- 1.) you substitute non-Atari parts in your coin-operated game, or
- 2.) you modify or alter any circuits in your Atari game by using kits or parts not supplied by Atari.

Not only may the use of any non-Atari parts void your warranty, but any such alteration may also adversely affect the safety of your game, and may cause injury to you and your players.

# Table of Contents

## 1 Location Setup

A. New Features	1
B. Game Inspection	3
C. Game Installation	3
1. Voltage Plug Selection	4
2. Interlock and Power On/Off Switches	4
D. Self-Test Procedure	6
E. Option Switch Settings	9
1. Bonus Play Feature	9
2. Coin Mechanism Multipliers	9
3. Examples of Game Price Settings	9
F. Game Play	13
1. Attract Mode	13
2. Ready-to-Play Mode	14
3. Play Mode	14
4. High Score Initial Mode	16

## 2 Maintenance and Repair

A. Cleaning	18
B. Fuse Replacement	18
C. The Control Panel	18
1. LED Start-Switch Replacement	19
2. Leaf-Switch Replacement	19
3. Mini-Trak Ball™ Maintenance and Repair	19
D. Monitor Removal	21
E. Printed-Circuit Board Removal	22
1. Game PCB Removal	22
2. Regulator/Audio II PCB Removal	22
F. Fluorescent Tube and Speaker Replacement	23
G. Game Operation	24

## 3 Illustrated Parts Lists

illustrations and parts lists begin on page 27

# List of Illustrations

Figure 1	Overview of Game .....	2
Figure 2	Installation Requirements .....	3
Figure 3	International Voltage Plug Selection .....	4
Figure 4	Interlock and Power On/Off Switches .....	5
Figure 5	Location of Self-Test Switch, Volume Control and Option Switches ...	6
Figure 6	Self-Test Procedure .....	7
Figure 7	Game                      Option                      Settings	10
Figure 8	Game Price Settings .....	11
Figure 9	Coin Counter Option Settings .....	13
Figure 10	Opening the Control Panel and Replacing Switches .....	18
Figure 11	Mini-Trak Ball™ Maintenance and Repair. ....	20
Figure 12	Monitor Removal .....	21
Figure 13	Printed-Circuit Board Removal .....	22
Figure 14	Fluorescent Tube Replacement. ....	23
Figure 15	Power Distribution .....	25
Figure 16	Signal Distribution .....	26
<i>Illustrated Parts Lists:</i>		
Figure 17	Cabinet-Mounted Assemblies .....	30
Figure 18	Control Panel Assembly .....	31
Figure 19	Mini-Trak Ball Assembly .....	32
Figure 20	Regulator/Audio II PCB Assembly. ....	34
Figure 21	Centipede™ GamePC <sup>R</sup> Assembly .....	36
Figure 22	Power Supply Assembly. ....	40
Figure 23	Fluorescent Light and Speaker Assembly. ....	42
Figure 24	American-Made Coin Door. ....	44
Figure 25	British-Made Coin Door .....	48

## NOTE

If reading through this manual does not lead to solving a certain maintenance problem, call Tele-Help® at the Atari Customer Service office in your geographical area, as shown below.

### WEST and CENTRAL U.S.A.

Parts for all Atari customers in the U.S.A. Game sales and service

Atari, Inc.  
 California Customer Service Office  
 1105 N. Fair Oaks Avenue  
 P. O. Box 427, Sunnyvale, CA 94086  
 Telex 17-1103  
 (Monday-Friday, 7:30-4:00 pm Pacific Time)

 From California, Alaska or Hawaii  
 (408) 745-2900

 From anywhere else in this area  
 toll-free (800) 538-1611

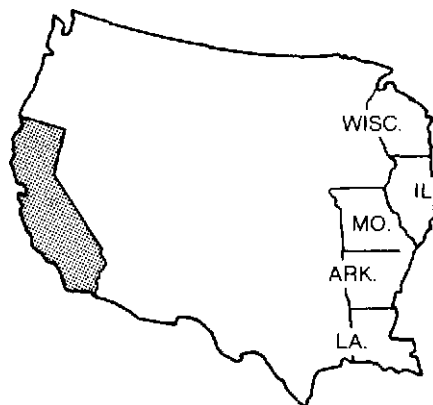

### EAST U.S.A.

Game sales and service only

Atari, Inc.  
 New Jersey Customer Service Office  
 Cottontail Lane, Somerset, NJ 08873  
 Telex 37-9347  
 (Monday-Friday, 7:30-4:00 pm Eastern time)

 From New Jersey  
 (201) 469-5993

 From anywhere else in this area  
 toll-free (800) 526-3849



### EUROPE

Parts for all Atari customers in Western Europe.

Game sales and service

Atari Ireland Limited  
 European Customer Service Office  
 Tipperary Town, Ireland  
 Telex 28165  
 (Monday-Friday, 9:00-6:00 pm GMT)

 062-52155

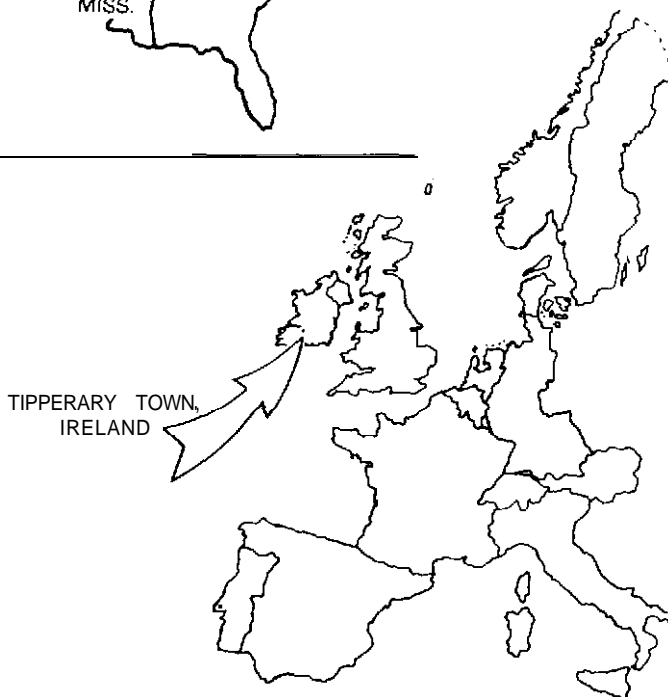

# Location Setup

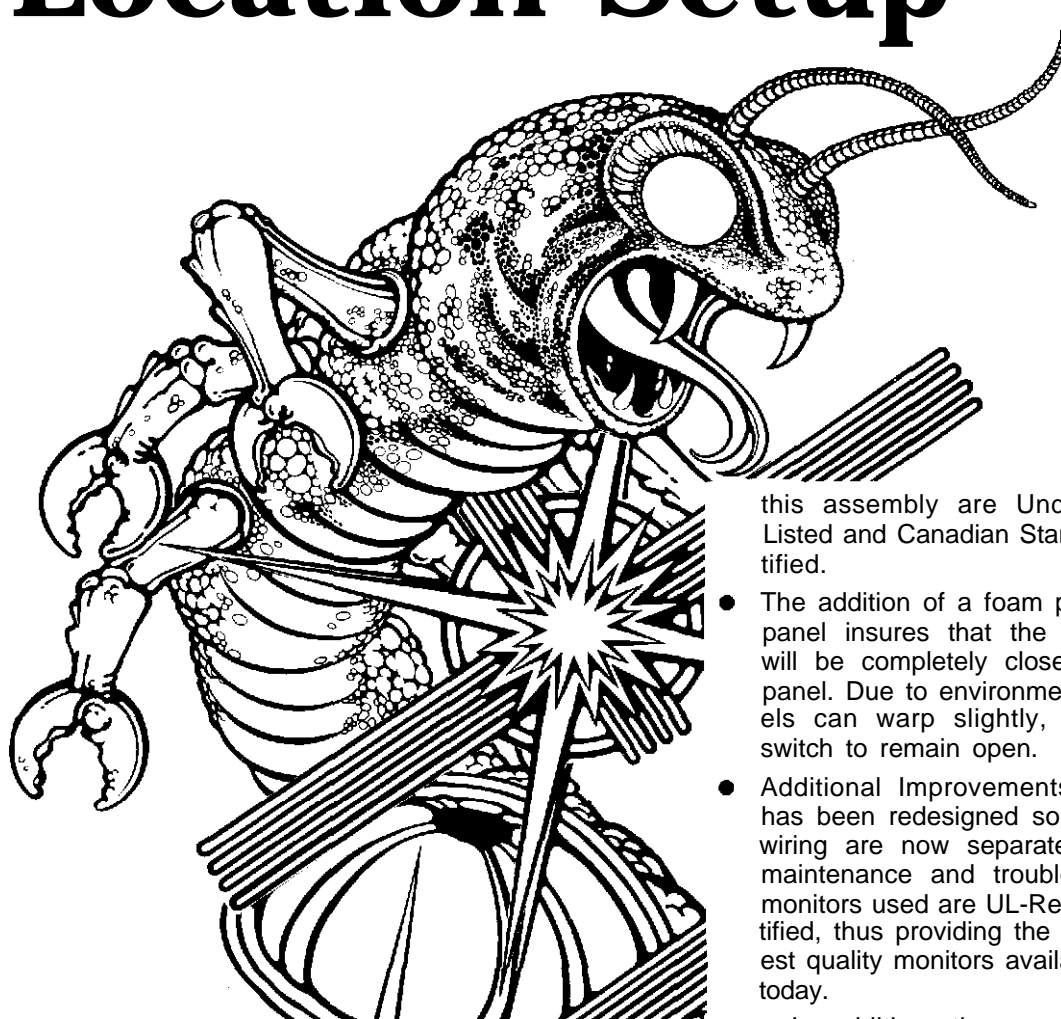

## A. New Features

The Centipede™ game has several new parts. Even if you are familiar with Atari games, you should note these important differences. The new parts are:

- **Mini-Trak Ball™** Assembly. The widely used Trak Ball assembly has been redesigned. The basis for this compact, simplified design is a two-part molded plastic frame. Fewer parts in this control make servicing easier, and its very smooth action is designed for greater player accuracy.
- The circuitry has non-volatile memory for part of the high score table. This means that even if power is removed from the game, the three highest scores will permanently stay in memory. To erase these scores follow the instructions in *Figure 6, Self-Test Procedure*.
- To insure starting, the fluorescent light now includes a large grounded metal plate. In addition, the lampholder and ballast transformer used in

this assembly are Underwriters Laboratories Listed and Canadian Standards Association Certified.

- The addition of a foam pad on the rear access panel insures that the safety interlock switch will be completely closed when you lock this panel. Due to environmental factors, these panels can warp slightly, which could cause a switch to remain open.
- Additional Improvements: The wiring harness has been redesigned so that signal and power wiring are now separated to provide ease of maintenance and troubleshooting. Second, all monitors used are UL-Recognized and CSA-Certified, thus providing the most reliable and highest quality monitors available in the marketplace today.

In addition, the power supply chassis has been fitted with a metal bottom plate making it a totally self-contained unit.

Fourth, the attraction panel and monitor shield are now made of tempered glass to facilitate cleaning and improve visibility.

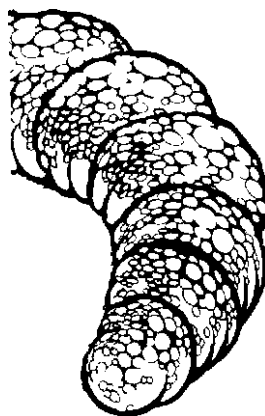

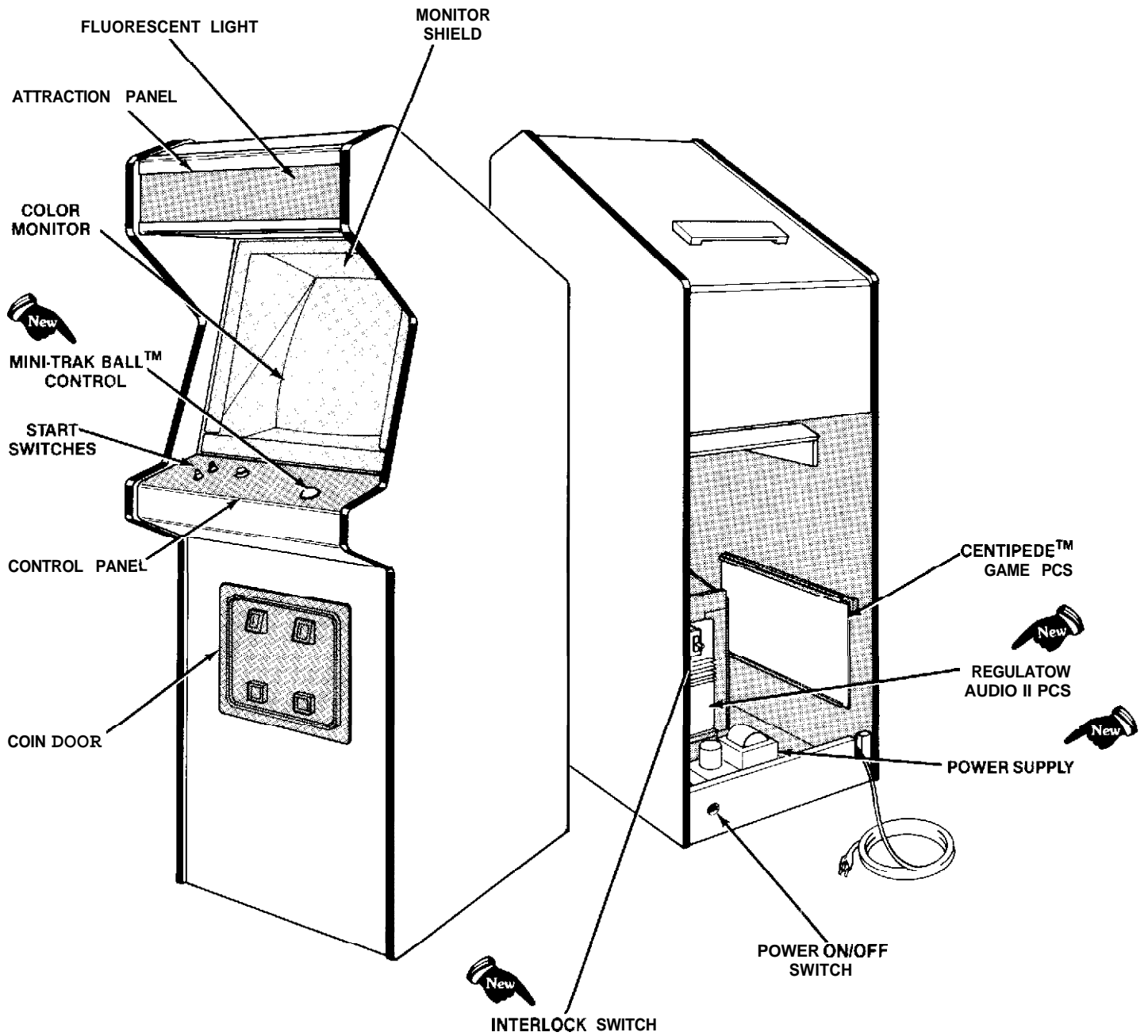

Figure 1 Overview of Game

## WARNING: SHOCK HAZARD

Connect this game only to a grounded 3-wire outlet. If you have only a 2-wire outlet, we recommend you hire a licensed electrician to install a grounded outlet. Players **may** receive **an electric shock** if this game is not properly grounded!

These new parts, as well as all other major parts in the game, are illustrated in Figure 1. Throughout this manual, wherever one of these new parts is mentioned, you will see this symbol:



## B. Game Inspection

This new game is ready to play upon removal from the shipping carton. However, your careful inspection is needed to supply the final touch of quality control. Please follow these steps to help us insure that your new game was delivered to you in good condition.

### NOTE

Do not plug the game in yet!

1. Examine the exterior of the game cabinet for dents, chips, or broken parts.
2. Remove the screws that were used as extra security to seal the rear access panel. Unlock and open this panel, as well as the coin door; inspect the interior of the game as follows:
  - Check that all plug-in connectors (on the game harness) are firmly seated. **Replug** any connectors found unplugged. Don't force connectors together. The connectors are keyed so they only go on in the proper orientation. A reversed edge connector will **damage** a PCB and will void your warranty.
  - Check that all plug-in integrated circuits on the game PCB are firmly seated in their sockets.
  - Remove the tie-wrap that holds the coiled power cord on the inside cabinet wall. Check the cord for any cuts or dents in the insulation. Place the square black metal strain-relief plate in the wood slot at the bottom of the rear panel opening.

## WARNING

To avoid possible unpleasant electrical shock, do not touch internal parts of the monitor with your hands or metal objects held in your hands!

- Note the location of the game's serial number—it is printed on the special label on the outside of the game cabinet. Verify that the serial numbers also stamped on the Centipede™ Game PCB, Regulator/Audio II PCB and monitor are all identical. A drawing of the serial-numbered components is on the inside front cover of this manual. Please mention this number whenever you call your distributor for service.
- Check all major subassemblies such as the power supply, control panel and monitor for secure mounting.

## C. Game Installation

### Figure 2 Installation Requirements

Power	130 watts
Temperature	0 to 38° C (32 to 100°F)
Humidity	Not over 95% relative
Space Required	64 × 82 cm (25¼ × 32¼ in.)
Game Height	181 cm (71¼ in.)

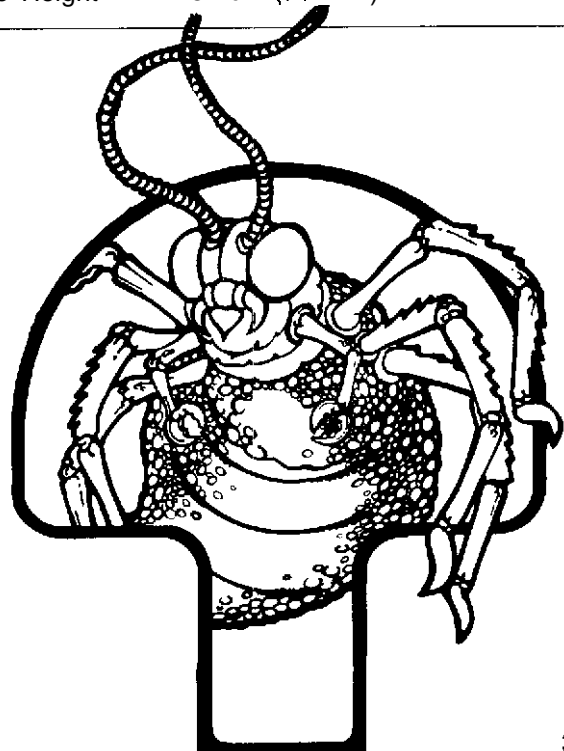



## 1. Voltage Selection

If you live outside the United States, your Centipede™ game has the “international” power supply with three colored plugs. Before plugging in your game, make sure that the voltage selection plug on the power supply (see Figure 3) is correct for your location’s line voltage. Check the wire color on the plug and see if it is correct per Figure 3.

## 2. Interlock and Power On/Off Switches

To minimize the hazard of electrical shock while working on the inside of the game cabinet, an interlock switch has been installed (see Figure 4). One is located behind the rear access panel and one is behind the coin door. These switches remove all AC line power from the game circuitry when a door is opened.

Check for proper operation of the interlock switches by performing the following steps:

- Se sure the access panel and the coin door are closed.
- Plug the AC line power cord into an AC outlet.
- Set the power on/off switch to the on position. Within approximately 30 seconds the monitor should display a picture.
- Slowly open the rear access panel. The monitor picture should disappear when the panel is opened approximately 2% cm (1 inch). Close and lock the access panel and repeat this step with the coin door.
- If the results of the preceding step are satisfactory, the interlock switches are operating properly. If the monitor doesn’t go off as described, check to see if the corresponding interlock switch is broken from its mounting or stuck in the on position.

### Line Voltage Range

90-110 VAC (100)  
 105-135 VAC (120)\*  
 200-240 VAC (225)  
 220-260 VAC (240)

### Voltage Selection Plug Color

Violet  
 Yellow\*  
 Blue  
 Brown

\*This is the *only* plug provided on the U.S. power supply. The international power supply includes the other three plugs.

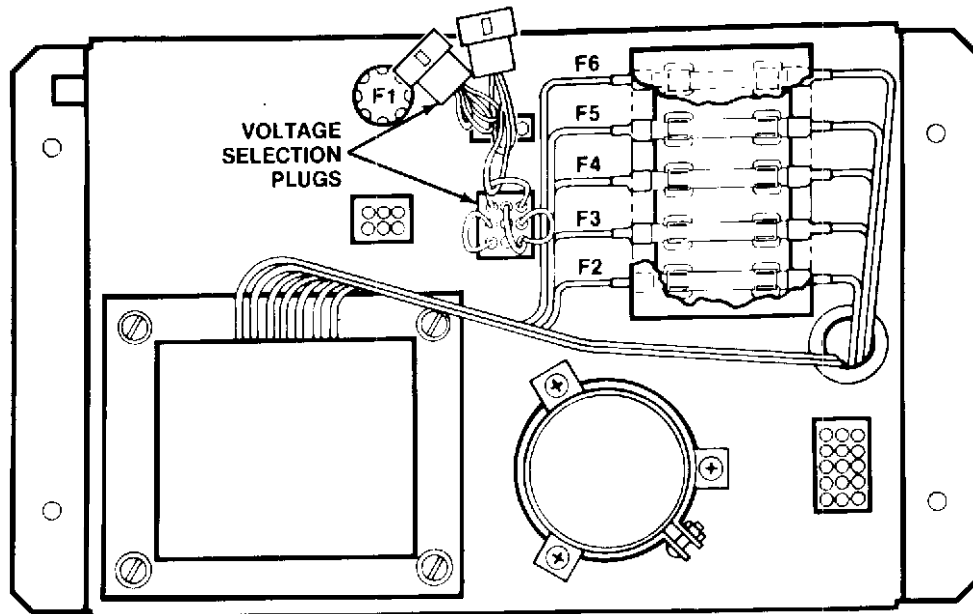
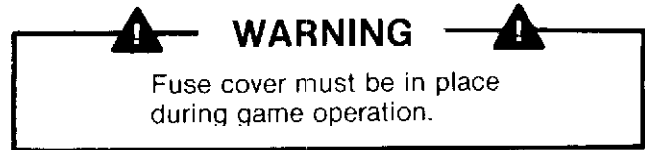

Figure 3 International Voltage Plug Selection

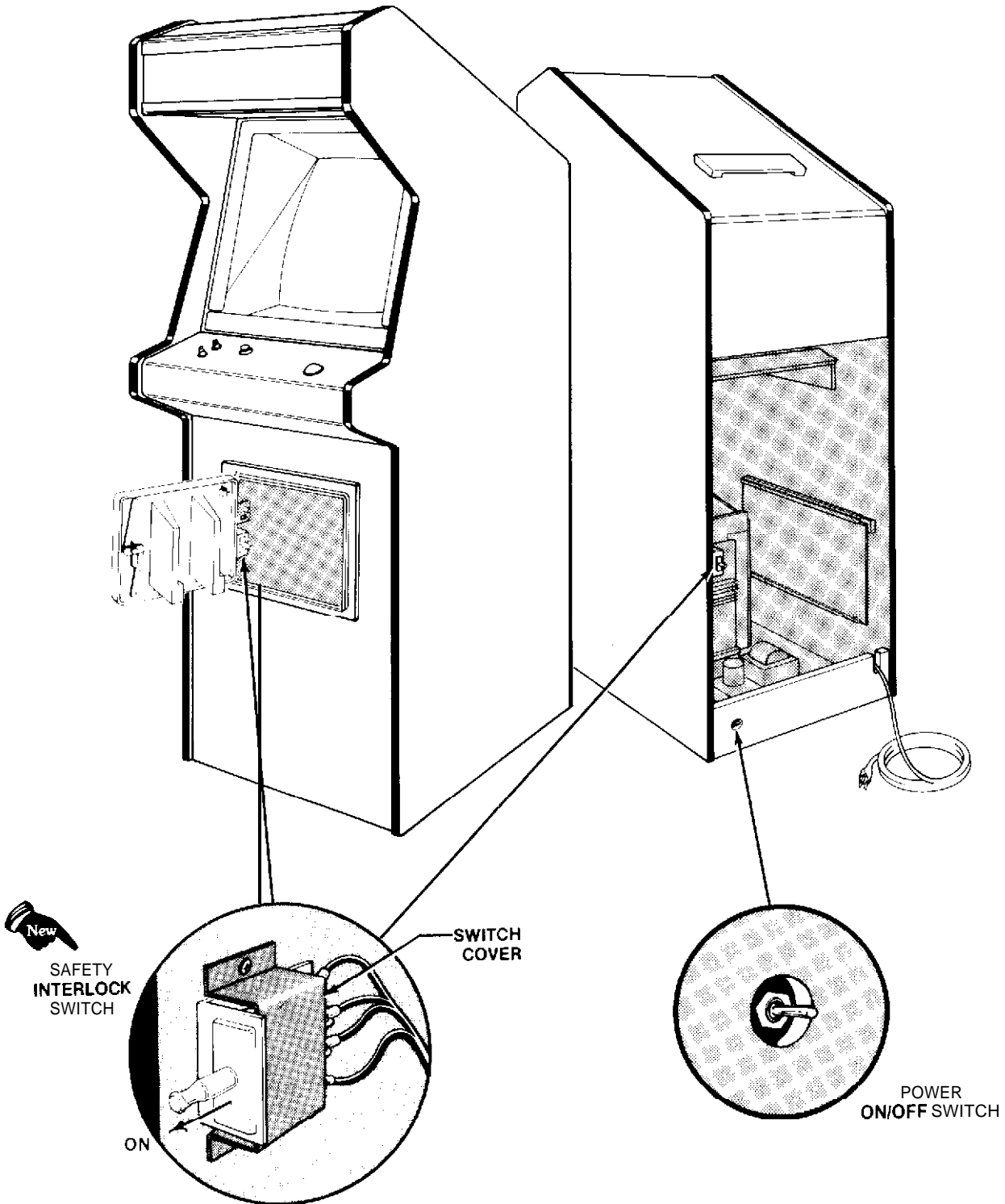

Figure 4 Interlock and Power On/Off Switches

# D. Self-Test Procedure

This game will test itself and provide data to demonstrate that the game's circuitry and controls are operating properly. The data is provided on the monitor, the light-emitting diodes in the start switches, and the game speaker; no additional equipment is necessary.

Part of the self-test procedure includes a display of the operator-selectable game options. Therefore, we suggest you run the self-test procedure anytime you need to change the game's options.

To run the self-test, follow the instructions outlined in Figure 6.

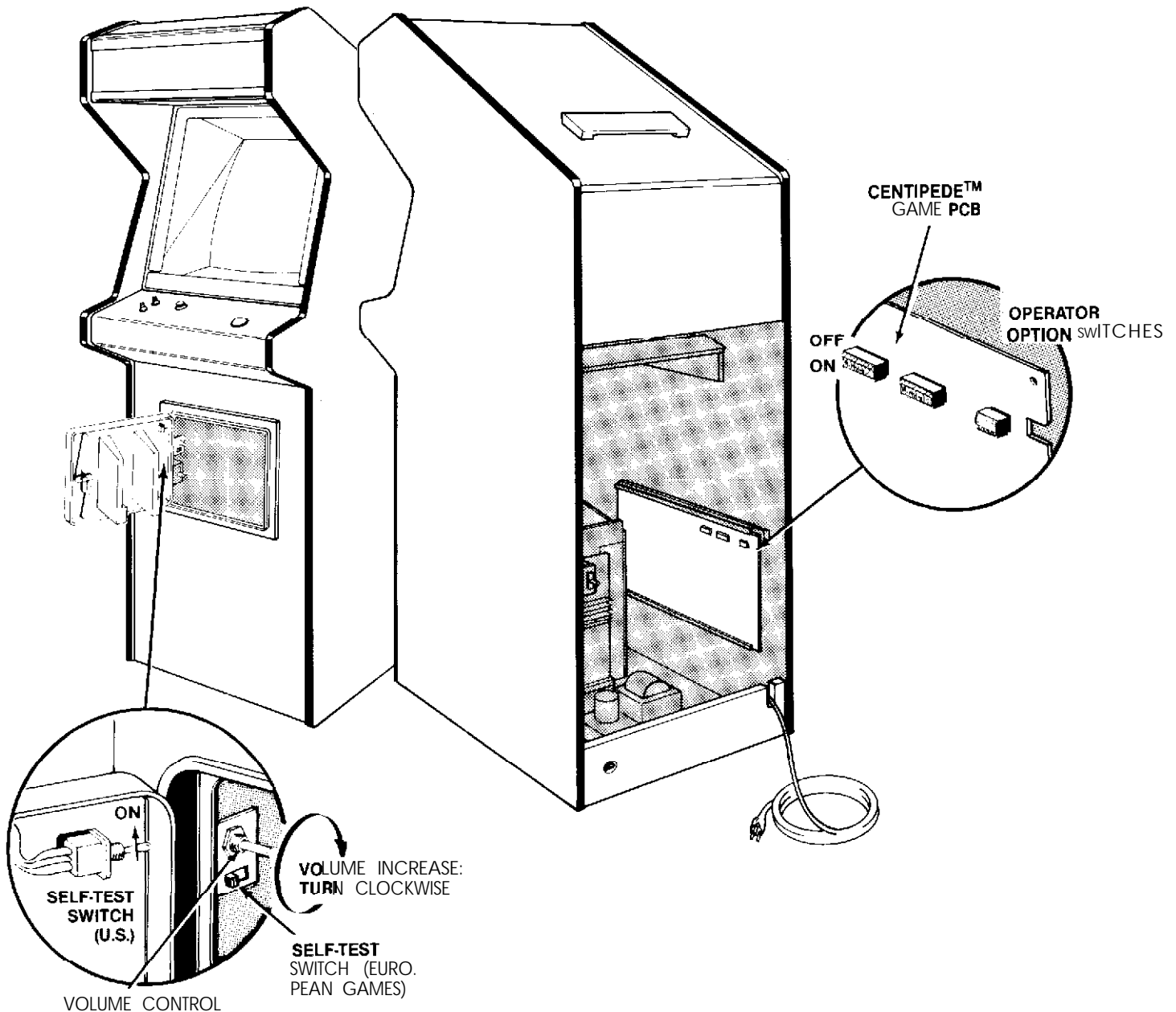
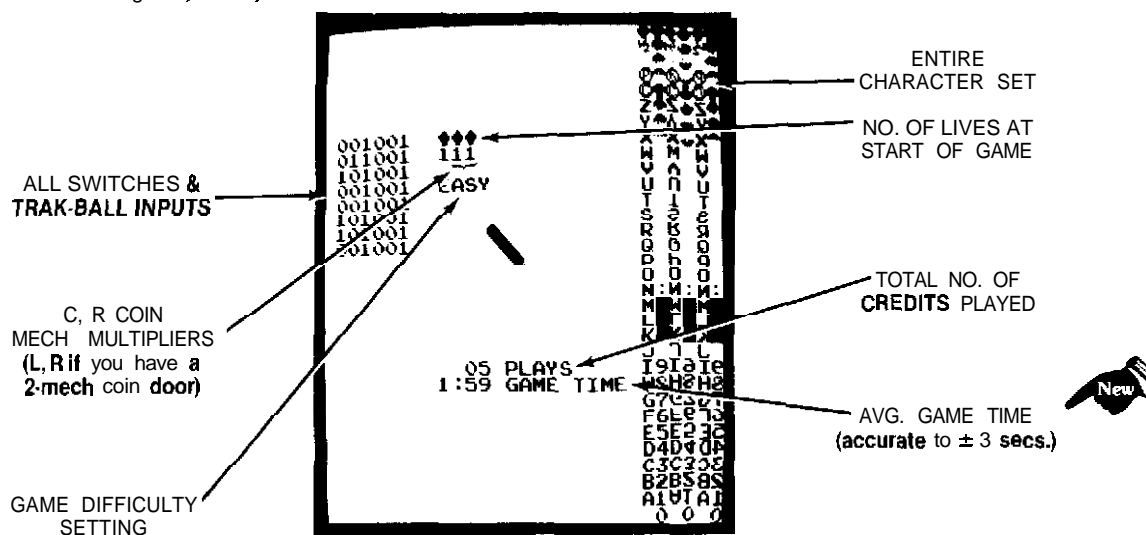

**Figure 5 Location of Self-Test Switch, Volume Control and Option Switches**

## Figure 6 Self-Test Procedure

Instruction	Results if Test Passes (if <b>results</b> are not as indicated, <b>see</b> list of failures that <b>follows</b> )
<b>1. Begin:</b> Set self-test switch to on position (see Figure 5).	The monitor displays the picture below. The game produces no sound at all. The two LEDs will stay on throughout self-test.
<b>2. Trak Ball Test:</b> Roll the Trak Ball control in all directions.	The centipede head moves around on the screen in directions corresponding to Trak Ball control.
<b>3. Switch Test:</b> One after another, activate and release all 3 control-panel switches, the slam switch, and coin door switches.*	As long as you activate (close) each switch, you'll hear a high beep.
<b>4. Audio I/O Chip Test:</b> One after another, press and hold 2 of the control-panel switches and at least one of the coin-door switches.	Volume increase* and pitch decreases with each additional switch that is activated.
<b>5. Audio I/O Channel Test:</b> Press I-player start button four times.	You'll hear a high beep for each press of the button.
<b>6. Background Color Test:</b> Press I-player start button at least eight more times.	Background color changes with each press of the I-player start button.
<b>7. Object Color Test:</b> Press Z-player start button at least 16 times*.	Objects on playfield change color.
<b>8. Moving Object Test:</b> Watch the screen, and move the Trak Ball around. Place the moving object in an open area of the screen. Press fire button several times.	Each press of the fire button changes the moving object to another moving object. At certain points in the series, the object will disappear. This is not a failure indication.
<b>9. Erasing the High Score Table (optional)</b> The current three highest scores are held in permanent memory even if the game is unplugged. If you want to erase these scores, first check that the number 4 is not displayed in the far upper left corner of the screen. If this number is not displayed, then simultaneously press the start and fire buttons. The 4 FF message in the upper left corner of the screen will then be displayed. The average game time data will also be erased, but still displayed on the screen. If 4 is present, then the scores will be erased when you return to the attract mode.	
<b>10. End:</b> When satisfied with test, set self-test switch to off position.	

\* Activate coin switches by inserting at least one coin in each coin slot. You will not trip the coin counters as long as you stay in self-test.



## Figure 6 Self-Test Procedure, continued

### Results if Test Fails

#### 1. Begin:

RAM **FAILURE** is indicated by one to 10 beeps. Note the number of beeps and determine which RAM may be bad. To restart the test; press the reset pushbutton on the game PCB, or set the self-test switch to off, then again to the on position.

Number of Beeps Given	Possible Bad RAM Chip Location
1	H2
2	F2
3	K7
4	K5
5	L7
6	L5
7	M7
8	M5
9	N7
10	N5

Any bad RAM must be replaced before the computer can check the Other RAMs, as well as continue with the self-test.

**ROM/PROM FAILURE** is indicated by two groups of numbers in the upper left corner of the screen. The number at the far left indicates the location of the failing PROM/ROM(s). Identify the bad ROM/PROM with the table below. If the screen displays "garbage," or the logic produces strange audio or randomly activates the coin counters, the chip at location J1 is probably bad.

Ignore the hexadecimal numbers just to the right of the chip-location number.

Displayed Number	Failing ROM/PROM Chip Location
0	D1
1	E1
2	F/H1
3 or "garbage"	J1
4*	E5*
5	B/C/D3



\*If you replace or erase this ROM, the number 4 FF will be displayed throughout the self-test. The next time you enter self-test, the 4 disappears after a game is played. Otherwise the self-test will continue to display the numbers 4 FF.

#### 2. Trak Ball Test:

The character doesn't move in same direction as ball, jumps rather than moves smoothly, or doesn't move at all, one of the Coupler PCBs on Trak Ball control may be bad, harness wires or connector may be loose. Trak Ball reading circuitry on Game PCB may be bad, or Trak Ball bearings may need oiling.

#### 3. Switch Test:

Sound is constantly on, even though you are not activating any switch. Or, no beep is given for any switch, or LED is dark. Indicates a bad switch, loose harness wires, bad LED-driving circuitry, volume turned all the way down, or loose connector.

#### 4. Audio I/O Chip Test:

No increase in volume or decrease in pitch indicates bad custom audio I/O chip at location B/C/D3.

#### 5. Audio I/O Channel Test:

On one out of the four activations, no audio is produced. Indicates one channel is bad in the custom I/O audio chip at location B/C/D3 (replace entire chip).

#### 6. Background Color Test:

Background doesn't change color, or doesn't display all 16 colors. Indicates bad color RAM chip. (RAM failure would have been indicated earlier with from 3 through 10 beeps.)

#### 7. Object Color Test:

Objects don't change color, or don't display all 16 colors. RAM failure.

#### 8. Moving Object Test:

Object doesn't change to another object. ROM/RAM failure.

## E. Option Switch Settings

### 1. Bonus Play Feature

Centipede™ offers a bonus play for certain combinations of coins inserted. This bonus feature is operator-selectable, meaning you may choose to offer it or not.

For example, with your game set at 50¢ per play, players who deposit four successive quarters or a \$1.00 coin, then press the start button, will receive a bonus coin. Therefore, players receive 3 plays for \$1.00.

This bonus feature encourages players to insert more money than just the minimum 50¢ you could require for one game. Various other bonuses are available (see Figure 8).

### 2. Coin Mechanism Multipliers

Available since early in 1980, Atari games have a new coin door which has either two or three mechanisms. All recent Atari game PCBs identify the different mechanisms in a certain pattern.

The right coin mechs are all the same to the game's logic, regardless of whether you have two or three mechs in your door. In addition, the logic sees the left mech in a 2-mech door and the center mech in a 3-mech door as the same. Refer to the diagram below,

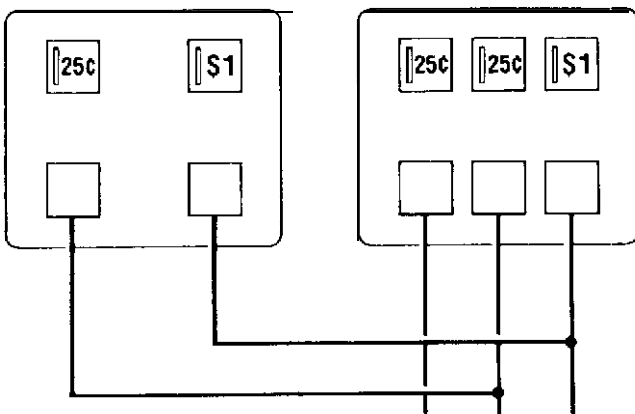

This pattern is important for you to know, so you can correctly set the "multipliers" for each mech. The multipliers determine how much each mechanism will be worth to the game's logic.

The basic unit of measurement is 25¢, which equals a multiplier of  $\times 1$ . Therefore, if you have a 25¢/25¢/\$1 coin door, you will probably want to set the center and right option-switch multipliers at  $\times 1/\times 4$ . (The left mech in a 3-mech door always has a value of  $\times 1$ —you cannot change its value.)

You can set these multipliers with toggles 3 thru 5 on the Centipede Game PCB switch assembly at location N8. For exact settings of these toggles, refer to Figure 8.

### 3. Examples of Game Price Settings

Figure 8 explains the options, giving twelve examples of the most common U.S. situations. The toggles mentioned are all in the switch at location N8; they only relate to game price, coin mechanism multipliers, and bonus play. You should set the toggles relating to other functions as you see fit, although Figure 7, 8, and 9 provide "\$" signs indicating Atari's recommendations.

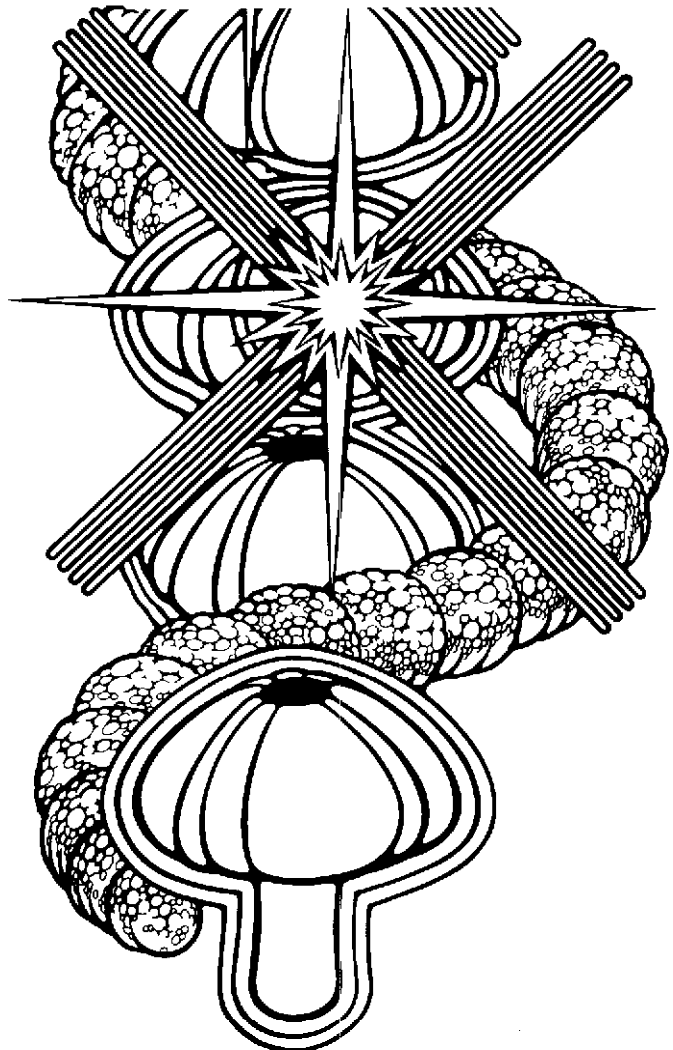

## Figure 7 Game Option Settings

To change toggle positions on the switch assemblies, you need no, remove the game PCS. The switches, usually colored blue, are easily accessible when the Centipede Game PCS is mounted in place.

When changing the options, verify proper results on the monitor display by performing the **self-test**. Note that changing an option on any of the following eight toggles will not cause an immediate change on the monitor screen during the attract mode.

Toggle Settings of &Toggle Switch cm Centipede Game PCS (at N9) (CENTER switch assembly when PCS is in game)								
8	7	6	5	4	3	2	1	Option
						On	On	English \$
						On	Off	German
						Off	On	French
						Off	Off	Spanish
				On	On			2 lives per game
				On	Off			3 live* per game \$
				Off	On			4 lives per game
				Off	Off			5 live* per game
		On	On					Bonus life granted at every:
		0 "	Off					10,000 points
		Off	0 "					12,000 points \$
		off	Off					15,000 points
								20,000 points
	On							Hard game difficulty* 
	Off							Easy game difficulty' \$
On								1-credit minimum \$
Off								2-credit minimum

\$ Manufacturer's suggested settings

\*Refer to **F. Game Play**, for information on game difficulty.

For pricing for "credits," see Figure 8.

Changing toggles 3-7 erases the high score table

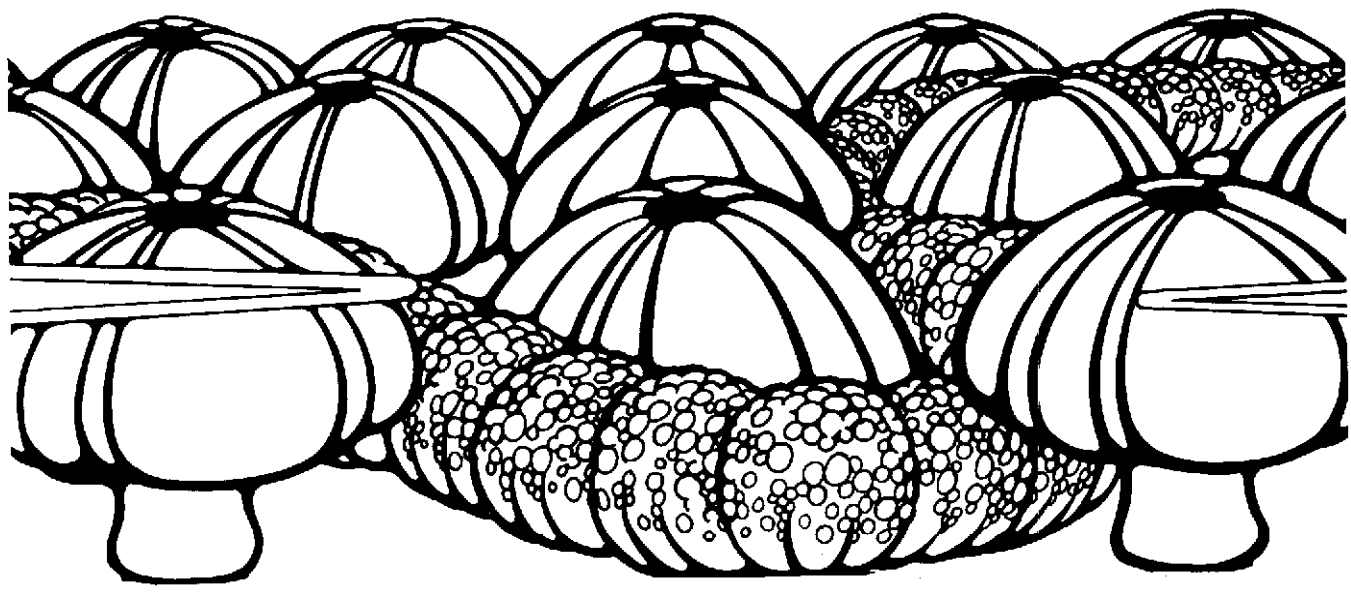

**Figure 8 Game Price Settings**

The white block below contains Atari's suggested settings. All numbers 1 thru 8 are toggle settings on the 8-toggle switch at location N8, on the Centipede™ Game PCS (the LEFT switch assembly).

Circled numbers refer to game pricing labels you should use with each situation (labels are on the following page). Use the label no. 6 (indicated with @) only if you set toggle 8 at PCB switch assembly Ng to off.

**50¢ PER CREDIT**

	No bonus	Bonus \$1.00 = 3 credits	Bonus \$.75 = 2 credits \$1.00 = 3 credits																																																		
<b>Straight 25¢ Door</b>	① <table border="1"> <tr><td>8</td><td>7</td><td>6</td><td>5</td></tr> <tr><td>Off</td><td>Off</td><td>Off</td><td>Off</td></tr> <tr><td>4</td><td>3</td><td>2</td><td>1</td></tr> <tr><td>Off</td><td>Off</td><td>On</td><td>On</td></tr> </table>	8	7	6	5	Off	Off	Off	Off	4	3	2	1	Off	Off	On	On	③ <table border="1"> <tr><td>8</td><td>7</td><td>6</td><td>5</td></tr> <tr><td>Off</td><td>On</td><td>On</td><td>Off</td></tr> <tr><td>4</td><td>3</td><td>2</td><td>1</td></tr> <tr><td>Off</td><td>Off</td><td>On</td><td>On</td></tr> </table>	8	7	6	5	Off	On	On	Off	4	3	2	1	Off	Off	On	On	④ <table border="1"> <tr><td>8</td><td>7</td><td>6</td><td>5</td></tr> <tr><td>Off</td><td>Off</td><td>On</td><td>Off</td></tr> <tr><td>4</td><td>3</td><td>2</td><td>1</td></tr> <tr><td>Off</td><td>Off</td><td>On</td><td>On</td></tr> </table>	8	7	6	5	Off	Off	On	Off	4	3	2	1	Off	Off	On	On		
8	7	6	5																																																		
Off	Off	Off	Off																																																		
4	3	2	1																																																		
Off	Off	On	On																																																		
8	7	6	5																																																		
Off	On	On	Off																																																		
4	3	2	1																																																		
Off	Off	On	On																																																		
8	7	6	5																																																		
Off	Off	On	Off																																																		
4	3	2	1																																																		
Off	Off	On	On																																																		
<b>25¢/\$1.00 Door or 25¢/25¢/\$1.00 Door</b>	① <table border="1"> <tr><td>8</td><td>7</td><td>6</td><td>5</td></tr> <tr><td>Off</td><td>Off</td><td>Off</td><td>Off</td></tr> <tr><td>4</td><td>3</td><td>2</td><td>1</td></tr> <tr><td>Off</td><td>On</td><td>On</td><td>On</td></tr> </table>	8	7	6	5	Off	Off	Off	Off	4	3	2	1	Off	On	On	On	③ <table border="1"> <tr><td>8</td><td>7</td><td>6</td><td>5</td></tr> <tr><td>Off</td><td>On</td><td>On</td><td>Off</td></tr> <tr><td>⑤</td><td>4</td><td>3</td><td>2</td><td>1</td></tr> <tr><td>Off</td><td>On</td><td>On</td><td>On</td></tr> </table>	8	7	6	5	Off	On	On	Off	⑤	4	3	2	1	Off	On	On	On	④ <table border="1"> <tr><td>8</td><td>7</td><td>6</td><td>5</td></tr> <tr><td>Off</td><td>Off</td><td>On</td><td>Off</td></tr> <tr><td>⑤</td><td>4</td><td>3</td><td>2</td><td>1</td></tr> <tr><td>Off</td><td>On</td><td>On</td><td>On</td></tr> </table>	8	7	6	5	Off	Off	On	Off	⑤	4	3	2	1	Off	On	On	On
8	7	6	5																																																		
Off	Off	Off	Off																																																		
4	3	2	1																																																		
Off	On	On	On																																																		
8	7	6	5																																																		
Off	On	On	Off																																																		
⑤	4	3	2	1																																																	
Off	On	On	On																																																		
8	7	6	5																																																		
Off	Off	On	Off																																																		
⑤	4	3	2	1																																																	
Off	On	On	On																																																		

**25¢ PER CREDIT**

	No bonus	□ onus \$.50 = 3 credits	Bonus \$1.00 = 5 credits																																																			
<b>Straight 25¢ Door</b>	② <table border="1"> <tr><td>8</td><td>7</td><td>6</td><td>5</td></tr> <tr><td>Off</td><td>Off</td><td>Off</td><td>Off</td></tr> <tr><td>⑥</td><td>4</td><td>3</td><td>2</td><td>1</td></tr> <tr><td>Off</td><td>Off</td><td>On</td><td>Off</td></tr> </table>	8	7	6	5	Off	Off	Off	Off	⑥	4	3	2	1	Off	Off	On	Off	⑥ <table border="1"> <tr><td>8</td><td>7</td><td>6</td><td>5</td></tr> <tr><td>Off</td><td>Off</td><td>On</td><td>Off</td></tr> <tr><td>⑦</td><td>4</td><td>3</td><td>2</td><td>1</td></tr> <tr><td>Off</td><td>Off</td><td>On</td><td>Off</td></tr> </table>	8	7	6	5	Off	Off	On	Off	⑦	4	3	2	1	Off	Off	On	Off	⑥ <table border="1"> <tr><td>8</td><td>7</td><td>6</td><td>5</td></tr> <tr><td>Off</td><td>On</td><td>Off</td><td>Off</td></tr> <tr><td>⑦</td><td>4</td><td>3</td><td>2</td><td>1</td></tr> <tr><td>Off</td><td>Off</td><td>On</td><td>Off</td></tr> </table>	8	7	6	5	Off	On	Off	Off	⑦	4	3	2	1	Off	Off	On	Off
8	7	6	5																																																			
Off	Off	Off	Off																																																			
⑥	4	3	2	1																																																		
Off	Off	On	Off																																																			
8	7	6	5																																																			
Off	Off	On	Off																																																			
⑦	4	3	2	1																																																		
Off	Off	On	Off																																																			
8	7	6	5																																																			
Off	On	Off	Off																																																			
⑦	4	3	2	1																																																		
Off	Off	On	Off																																																			
<b>25¢/\$1.00 Door or 25¢/25¢/\$1.00 Door</b>	② <table border="1"> <tr><td>8</td><td>7</td><td>6</td><td>5</td></tr> <tr><td>Off</td><td>Off</td><td>Off</td><td>Off</td></tr> <tr><td>⑥</td><td>4</td><td>3</td><td>2</td><td>1</td></tr> <tr><td>Off</td><td>On</td><td>On</td><td>Off</td></tr> </table>	8	7	6	5	Off	Off	Off	Off	⑥	4	3	2	1	Off	On	On	Off	⑥ <table border="1"> <tr><td>8</td><td>7</td><td>6</td><td>5</td></tr> <tr><td>Off</td><td>Off</td><td>On</td><td>Off</td></tr> <tr><td>⑦</td><td>4</td><td>3</td><td>2</td><td>1</td></tr> <tr><td>Off</td><td>On</td><td>On</td><td>Off</td></tr> </table>	8	7	6	5	Off	Off	On	Off	⑦	4	3	2	1	Off	On	On	Off	⑥ <table border="1"> <tr><td>8</td><td>7</td><td>6</td><td>5</td></tr> <tr><td>Off</td><td>On</td><td>Off</td><td>Off</td></tr> <tr><td>⑦</td><td>4</td><td>3</td><td>2</td><td>1</td></tr> <tr><td>Off</td><td>On</td><td>On</td><td>Off</td></tr> </table>	8	7	6	5	Off	On	Off	Off	⑦	4	3	2	1	Off	On	On	Off
8	7	6	5																																																			
Off	Off	Off	Off																																																			
⑥	4	3	2	1																																																		
Off	On	On	Off																																																			
8	7	6	5																																																			
Off	Off	On	Off																																																			
⑦	4	3	2	1																																																		
Off	On	On	Off																																																			
8	7	6	5																																																			
Off	On	Off	Off																																																			
⑦	4	3	2	1																																																		
Off	On	On	Off																																																			



### Figure 8 Game Price Settings, continued

The switch settings below relate to options for game price, coin mechanism multipliers, and bonus play. This information is useful in case you need to temporarily set the Centipede™ game on free play, or if you have German coin mechanisms in your door.

To achieve bonus plays, all coins must be inserted before pressing the start button. The label no. 6 shown below should be used only if you set toggle 8 at PCB switch assembly N9 to off.

Toggle Settings of 8-Toggle Switch on Centipede PCS (at N8), LEFT switch when PCB is in game							1	Option
8	7	6	5	4	3	2		
						On	On	Free play
						On	Off	1 coin' for 2 credits
						Off	On	1 coin* for 1 credit \$
						Off	Off	2 coins' for 1 credit
				On	On			Right coin mech x 1\$
				On	Off			Right coin mech x 4
				Off	On			Right coin mech x 5
				Off	Off			Right coin mech x 6
			On					Left coin mech x 1 \$
			Off					Left coin mech x 2
On	On	On						No bonus coins \$
On	On	Off						For every 2 coins* inserted, game logic adds 1 more coin*
On	Off	On						For every 4 coins' inserted, game logic adds 1 more coin*
On	Off	Off						For every 4 coins* inserted, game logic adds 2 more coins'
Off	On	On						For every 5 coins* inserted, game logic adds 1 more coin*
Off	On	Off						For every 3 coins* inserted, game logic adds 1 more coin*

\*In the U.S., a "coin" is defined as 25¢ In Germany a "coin" is 1 DM.

\$ Manufacturer's suggested settings

#### Game Pricing Labels

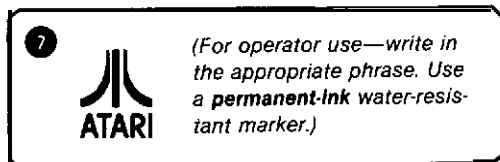
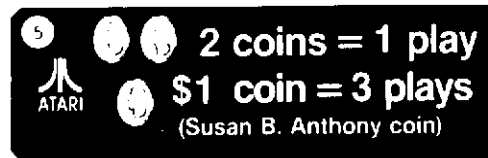
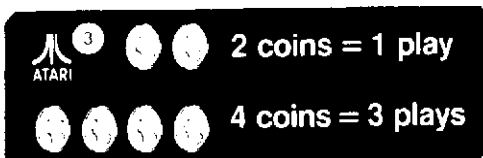

## Figure 9 Coin Counter Option Settings

[These toggles determine which coin mechanisms *activate* which *counters*]

Toggle Settings of 4-Toggle Switch on Game PCS (N11)				Two coin acceptors in <i>the coin door</i> :	Two coin acceptors and a push-button utility coin switch in the <i>game</i> :	Three coin acceptors in <i>the coin door</i> :
4	3	2	1			
		On	On	Both acceptors activate all coin counters simultaneously.	<i>Do not use this setting.</i>	All 3 are same denomination and they activate all coin counters simultaneously.
		On	Off	Both acceptors activate 2 counters separately.	<i>Do not use this setting.</i>	Left and center acceptor activate one coin counter; right acceptor activates another coin counter.
Not Used	Not Used	Off	On	Both acceptors activate all coin counters simultaneously.	Utility coin switch will not activate a coin counter, if you do not hook it up. Both acceptors activate all coin counters simultaneously.	Left acceptor activate* one coin counter; center and right acceptor activate another coin counter. <i>Not for any currently designed 3-mech coin door.</i>
		Off	Off	Both acceptors activate 2 counters separately. \$	Utility coin switch will not activate a coin counter, if you do not hook it up. Left and right acceptors activate 2 coin counters separately.	Left, center and right acceptors activate 3 coin counter* separately. \$

\$ *Manufacturer's suggested settings*

## F. Game Play

Atari's Centipede™ game is a one- or two-player game with a color raster-scan monitor. The fast-moving action includes a variety of creatures dropping down from the top of the screen or flying in from its sides, most of them to attack the player. The player's shooter is represented on the screen by a somewhat humanoid head.

The player's goal is to shoot at and destroy as many of these creatures and mushrooms as possible for a high point score, before the player's lives are used up. Players can maneuver their Trak Ball™ control anywhere within approximately the bottom fifth of the screen. However, they must move around mushrooms, since these are fixed, not "transparent", objects. A fire button shoots individual shots upwards, or fires a hail of shots if pressed constantly. (Only one shot appears on the screen at a time.)

The game has five possible modes of operation: attract, ready-to-play, play, high score initial, and self-test. Self-test is a special mode for checking the game switches and computer functions. You may enter this mode at any time. When entered, all game credits are cancelled. Wait at least eight seconds

after a game has been played before entering self-test or turning off the power. Otherwise, you may erase the high score table.

### 1. Attract Mode

The attract mode begins when power is applied to the game, after a play or high score initial mode, or after self-test. This mode is continuous and is only interrupted when a game is paid for and accepted or when in self-test. In this mode, the monitor displays two pictures simultaneously.

One of the pictures is operator-selectable for one of four languages. Placed in the center of the screen, the picture shows the high score table, game price, and the bonus-life achievement level. If the operator sets the Centipede game for free play, the game will not display a game price message.

The high score table shows the eight highest scores and their matching initials. If you erase the special "permanent" memory (see Figure 6, Self-Test Procedure), then this table will contain fictitious scores and initials. The table is redeveloped from subsequent games with scores of more than 12,102 points. Subsection 4, High Score *Initial Mode*, explains this table in more detail.



Operators may choose one- or two-credit minimums by selecting one of the option switch settings on the game PCB (see Figure 7, Game Option Settings).

If the game is set for a 2-credit minimum, that message will be displayed on the screen. (No special message appears if Centipede is set to the opposite setting, namely i-credit minimum.)

The other picture surrounds the high score table, game price and bonus-life achievement level messages. That picture displays a typical game-play sequence, with a field of colorful mushrooms through which a centipede crawls. The spiders bounce in from the sides of the screen, and fleas occasionally drop down from the top. In addition, scorpions will cross the screen at almost any point.

In this mode, the action exactly duplicates a typical game played by a moderately skilled player: the player's shooter moves freely within the limits of motion, shooting at spiders, centipedes, fleas and scorpions. Periodically the player is "destroyed" when a flea, spider or centipede head or body collides with the player's shooter.

All the colors on the screen change with each wave. A new wave occurs when the player shoots all centipede parts remaining on the screen. At this point, a new centipede starts snaking its way down from the top of the screen.

The attract mode differs from real game play in that no head figures are shown at the top of the screen to represent the number of lives remaining, no sounds are produced, no scores are incremented, and none of the four player controls work.

At any time when the game is powered up, if the coin-door slam switch is closed, you will hear a special alarm sound. This sound alerts location personnel that the game has been abused.

## 2. Ready-to-Play Mode

This mode begins when sufficient coins are accepted for a one- or two-player game. It ends when the i-player start or 2-player start pushbutton is pressed. When this mode begins, the message *CRE-DITS\_ is* displayed in the middle of the screen. The pictures are otherwise the same as those shown in the attract mode.

If you select the two-credit minimum and a player inserts enough *money for only one* credit, the message *2 CREDIT MINIMUM* flashes on the screen until enough coins for the second credit are inserted.

In addition, *CREDITS 0½* is displayed if you have selected the option of two coins per credit, and the player has inserted only one coin. A "credit" is defined as the cost for each player to play one game. In other words, two credits will pay for:

- one player playing two games, or
- two players playing one game.

## 3. Play Mode

The play mode begins when any flashing start pushbutton is pressed. The mode ends when the player's last life is lost.

A player's shooter is enabled at the beginning of the play mode, and the audio starts. The appropriate LED start switch will then stay lighted until the end of the game. At this point it will flash if any credit remains.

The game begins with a playfield of randomly placed mushrooms. A centipede starts snaking its way across from the center top of the screen. The centipede changes direction when it runs into a mushroom or either the left or right boundaries of the playfield.

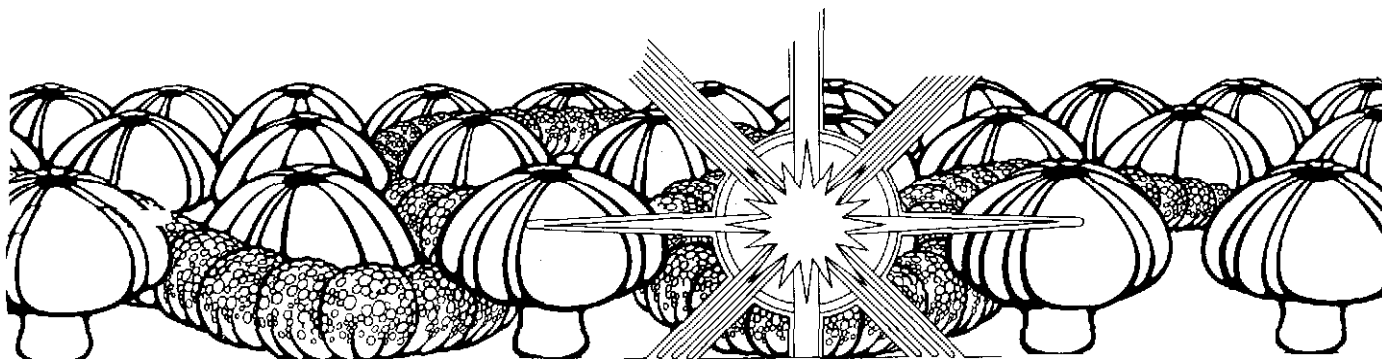

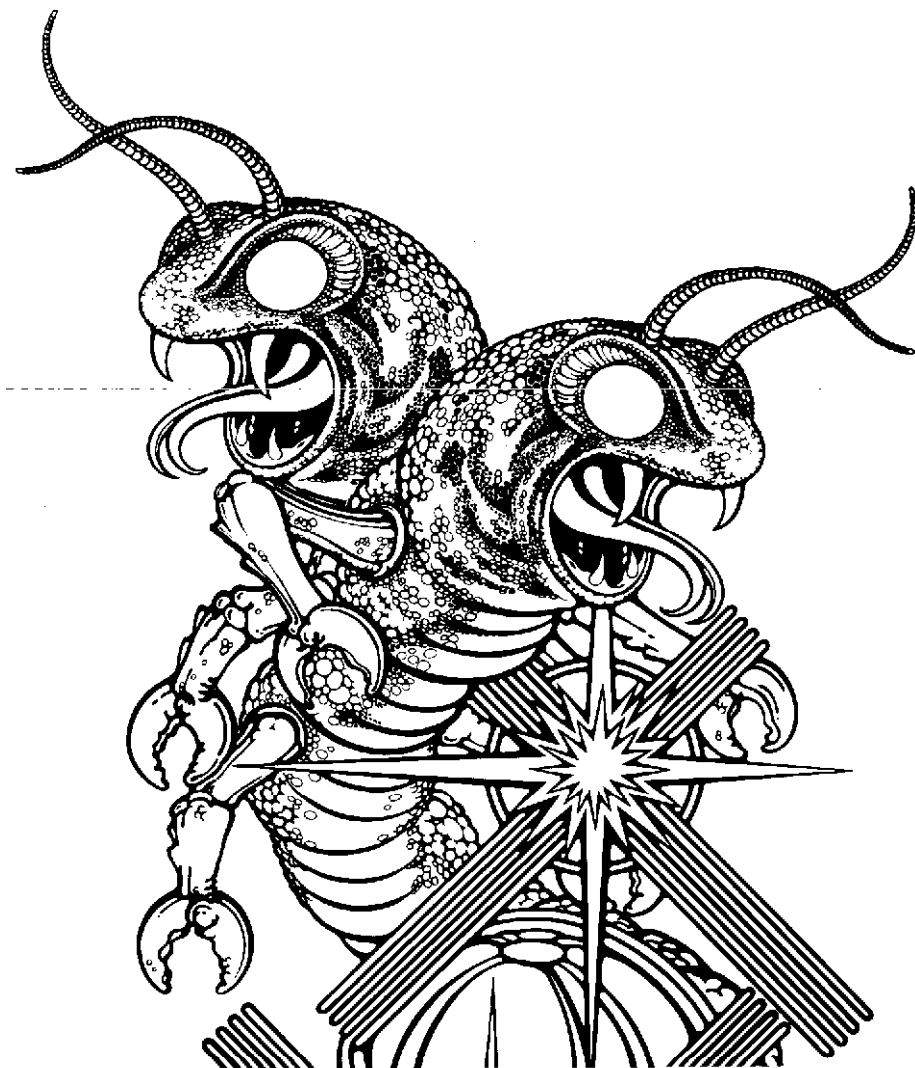

When a centipede is shot, it breaks into two smaller ones, each with a head. Also, the part of the centipede that was shot leaves a mushroom in its place on the screen. When any centipedes reach the bottom of the screen, they start back up, but remain within the area of the player's shooter (the bottom fifth of the screen).

When a large centipede (that hasn't been shot yet) reaches the bottom, it releases its tail, and this part changes into a new head. Also to provide player challenge, if a centipede is still alive when it reaches the bottom, new heads will enter the screen almost at the bottom of the sides. More of these heads will appear as time progresses.

The randomly moving spiders also appear in the first wave. The spiders can destroy a player, as well as any mushrooms they move over. This eliminates many mushroom targets for a player.

The player's shooter is moved by rotating the Trak Ball™ control. The shooter can be moved in all directions, but only within the bottom fifth of the screen. Pressing the fire button causes the shooter to fire shots upwards, either singly or in rapid-fire mode, if held down constantly.

Mushrooms count 1 point when shot, and a player must fire four shots into a mushroom before it is destroyed and disappears. Centipede body parts count 10 points each, and the elusive heads (represented with small eyes on them) are worth 100 points each. Spiders are worth 300, 600 or 900 points, depending on how close they are to the player when shot.

A bombardment of fleas starts in the second wave; as the fleas descend, they leave a trail of new mushrooms behind them.

In the second wave, the fleas appear when a certain number of mushrooms remains at the bottom of the screen. This number increases as the game progresses, meaning fleas appear more often later on in the game.

Fleas have a value of 200 points when shot, and players must hit them twice to destroy them (the first shot just speeds them up).

The scorpion enters from either side starting in the fourth wave; it moves at a relatively slow speed. Later it increases its speed. When shot, a scorpion counts 1000 points—the highest-value target of all.

As it travels across the screen, it "poisons" the mushrooms that it moves over and changes their colors. These mushrooms cause any centipedes that would collide with them to head straight towards the bottom of the screen, rather than continue snaking around. Players can stop a poisoned centipede by shooting its head.

In addition, these poisoned mushrooms as well as any partially shot mushrooms add 5 points to the player's score at the end of each life when the screen is resetting.

If the players are very skilled and earn at least 60,000 points, two things happen to increase player challenge: the fleas descend at a faster speed and the spiders restrict their movement to a smaller area at the bottom of the screen.



An important new feature of this game is the operator option for easy/hard game difficulty. In the easy game, the spider moves slowly up to a 5,000-point score, and then bounces at a higher speed. It also changes direction less often throughout the game than at the hard setting.

In the hard setting, the spider moves slowly only for the first 1,000 points, and then speeds up. It also changes direction more often throughout the game. In either setting, the spider always moves at a 45-degree angle or straight up and down.

Another operator option is the number of lives per game, ranging from 2 to 5 (see Figure 7 for switch settings). This number is displayed as small shooters at the top of the screen. The number is de-

creased by one each time a player is destroyed. The number is increased by one each time the player scores multiples of 10, 12, 15 or 20 thousand points, depending on the operator selection.

### 4. High Score Initial Mode

If a player's score exceeds the minimum on the high score initial list, he or she may put up to three initials on this list at the end of the game. At the beginning of this mode, the characters A \_\_ appear on the screen. The logic will also display the messages *GREAT SCORE* and *ENTER YOUR INITIALS*.

Players enter initials one character at a time, choosing from the characters A thru Z and a blank space. Pressing the fire button selects the letter, and rolling the Trak Ball control changes the letters on the screen.

After the fire button is pressed the third time, the initials and score are transferred to the table. This table contains eight scores and appears during the attract and ready-to-play mode.

All but the highest three scores are erased whenever you enter the self-test, or press the RESET button on the game PCB, or turn off the power. This re-setting replaces the lowest five scores with fictitious scores and initials.



If you erase the special "permanent" memory, the high score table is replaced with eight fictitious scores and initials. In other words, the table will always be displayed on the screen, possibly consisting of one or more realistic scores and players' initials.

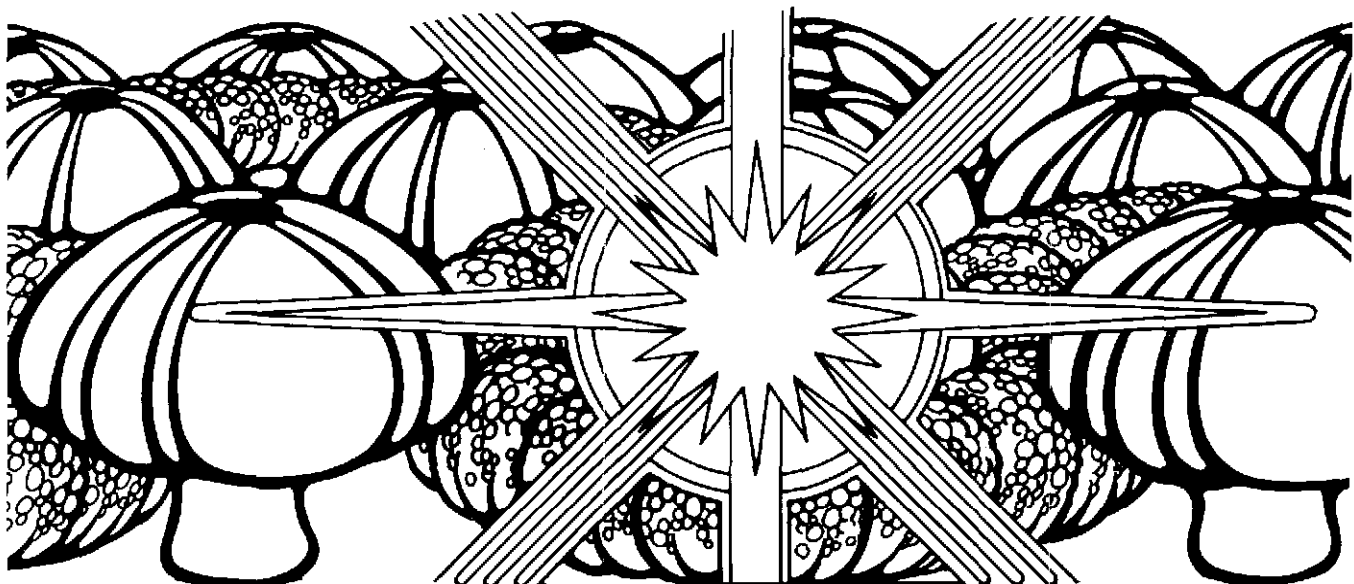

# Maintenance and Repair

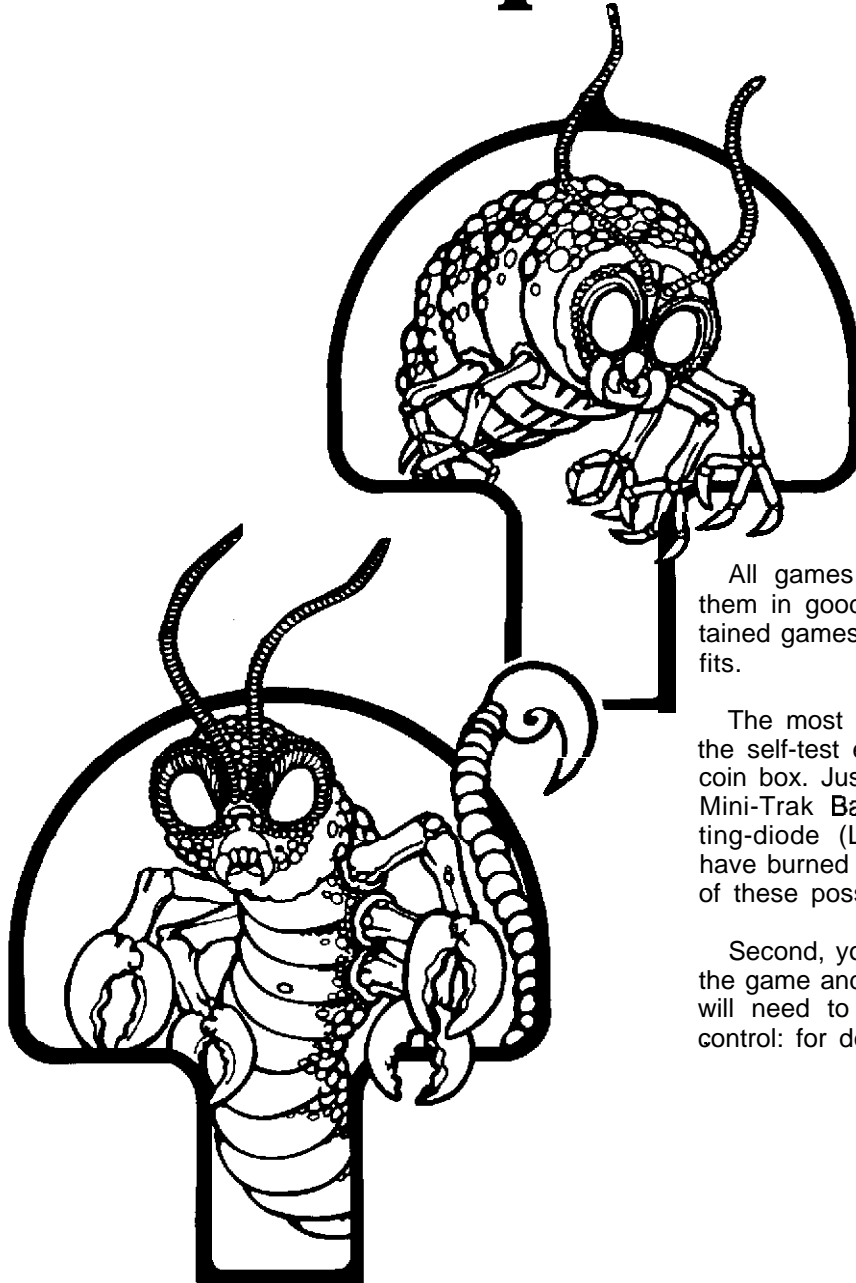

All games require certain maintenance to keep them in good working order. Clean, properly maintained games will attract players and earn more profits.

The most important maintenance item is running the self-test every time you collect money from the coin box. Just looking at a game will not tell you if Mini-Trak Ball™ control, leaf switch or light-emitting-diode (LED) switches are broken, or if LEDs have burned out. The self-test will inform you of any of these possible problems.



Second, you should regularly clean the outside of the game and the coin mechanisms. In addition, you will need to regularly lubricate the Mini-Trak Ball control: for details see this chapter.



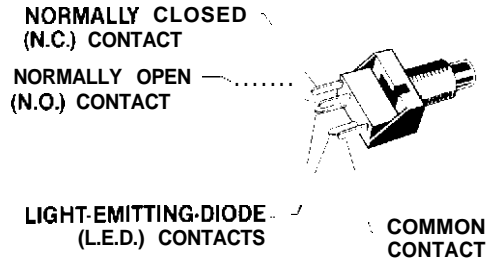

**CAUTION**  
 Players may receive an electric shock if this control panel is not properly grounded! After servicing any parts on the panel, check that the ground wire is firmly attached to the metal tab on the inside of the control panel. Only *then* should you lock up the game.

**To remove LED switch:**

- Remove all wires from the faulty switch.
- Turn the switch counterclockwise while holding the black cone-shaped bushing on the outside of the control panel.
- Install a new switch using the reverse procedure.
- Reconnect the harness wires.

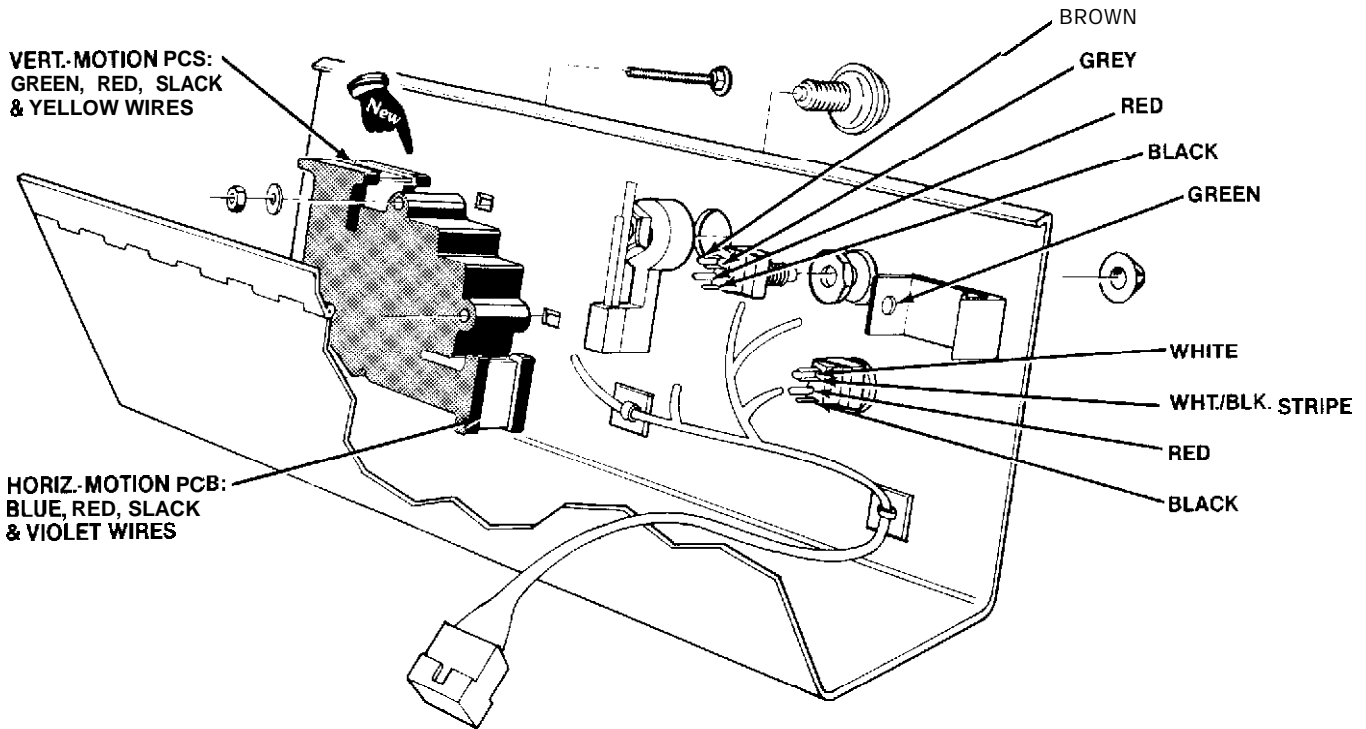

**Figure 10 Opening the Control Panel and Replacing Switches**

## A. Cleaning

The exterior of the game cabinet and the metal and glass surfaces may be cleaned with any non-abrasive household cleaner. If desired, special coin machine cleaners that leave no residue can be obtained from your distributor.

The large monitor shield and the attraction panel are made of tempered glass and should be scratch-resistant: if cleaned without abrasive substances, you should hardly ever have to replace them.

## B. Fuse Replacement

This . . . . game contains six fuses—all on the power supply assembly (not including the monitor fuses). Replace fuses only with the same type as listed in Figure 22 of this manual. See the color monitor manual for the monitor fuse data.

## C. The Control Panel

Prior to repairing or replacing any switch or the Mini-Trak Ball™ on the control panel, unplug the game. Then open the coin door.

Reach through the coin-door opening and open the luggage-style latch, located at each end on the underside of the control panel (see Figure 10). Lift up on the control panel at the topmost edge and tilt it towards you.

The edge of the control panel next to the monitor shield has foam tape applied to it. This tape acts as a cushion for the glass and prevents spilled liquids from entering the cabinet interior. Always make sure this tape is in good condition.

## 1. LED Switch Replacement

The light-emitting diode (LED) switches on the control panel have a very low failure rate. In case a switch should ever be suspect, first test it per the description that follows. To replace the switch, refer to Figure 10.

1. Remove the wires from the suspected switch.
2. Set multimeter to ohms scale. Set ohms scale to Rx1, then zero the meter.
3. Connect multimeter leads to appropriate LED switch contacts (see Figure 10 for designation of switch contacts).
4. Check contacts (push and release the switch button) for closed and open continuity.
5. If the contacts do not operate sharply or always remain closed or open, then replace the LED switch as outlined in the figure.

## 2. Leaf-Switch Replacement

The leaf switch on this game operates on 5 volts at a very low current. Therefore, pitting of the switch would be extremely rare. Probably the only reason that pitting would occur is that the game is in very high-humidity locations.

**Don't** burnish **the** switch contacts. Burnishing them removes their plating, thus increasing the corrosion of the contacts. **The best method of cleaning the switch contacts is to wipe them with a non-abrasive surface.** A business card works very well.

To replace the switch, remove both of its screws with a Phillips-head screwdriver.

If the white button itself needs to be replaced, turn the stamped nut with a wrench in a counter-clockwise direction, as seen from the inside of the control panel. The white ring on the outside of the control panel should not spin, due to its design.

### NOTE

Adjust switch for a narrow gap. When a switch button is depressed, the resulting wiping action of the contacts provides a self-cleaning feature.

## 3. Mini-Trak Ball™ Maintenance and Repair

To maintain this control, lubricate the bearings approximately every 3 months or **every** 6,000 credits. The number of credits can be read off the coin counter, located on the coin door. Use only 2 drops of 3-in-One® oil in each of the ball bearings. (Each Mini-Trak Ball™ control has six bearings.)

For further instructions on how to replace the ball, either coupler PCB or either encoding wheel, see Figure 11.

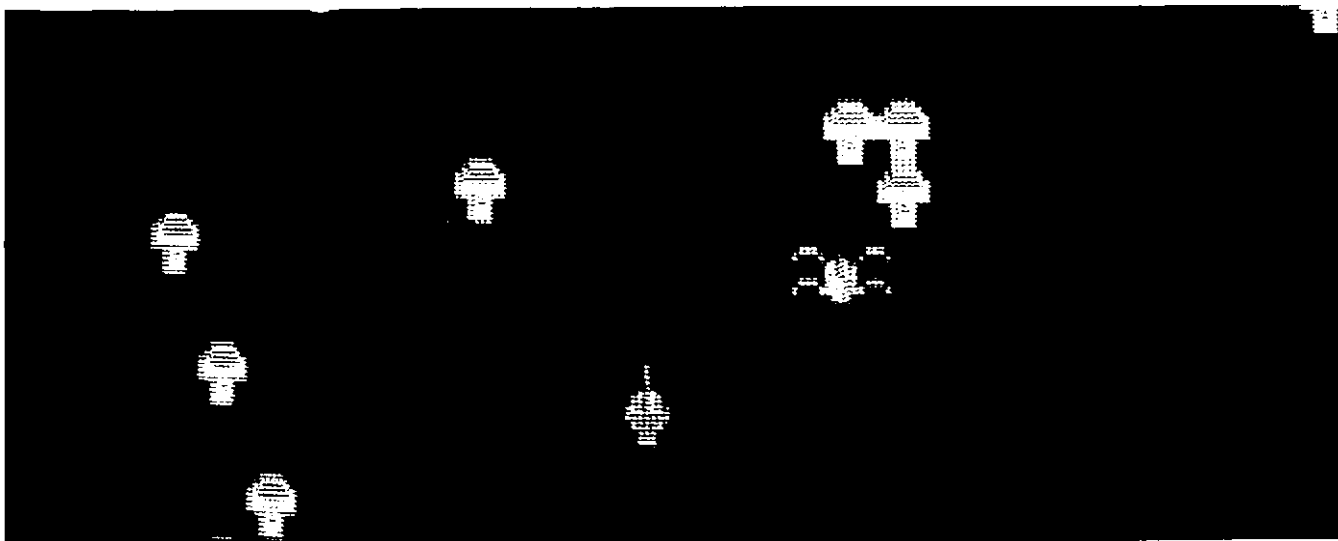



Disassemble in the order indicated. (Circled numbers match the steps described below.)

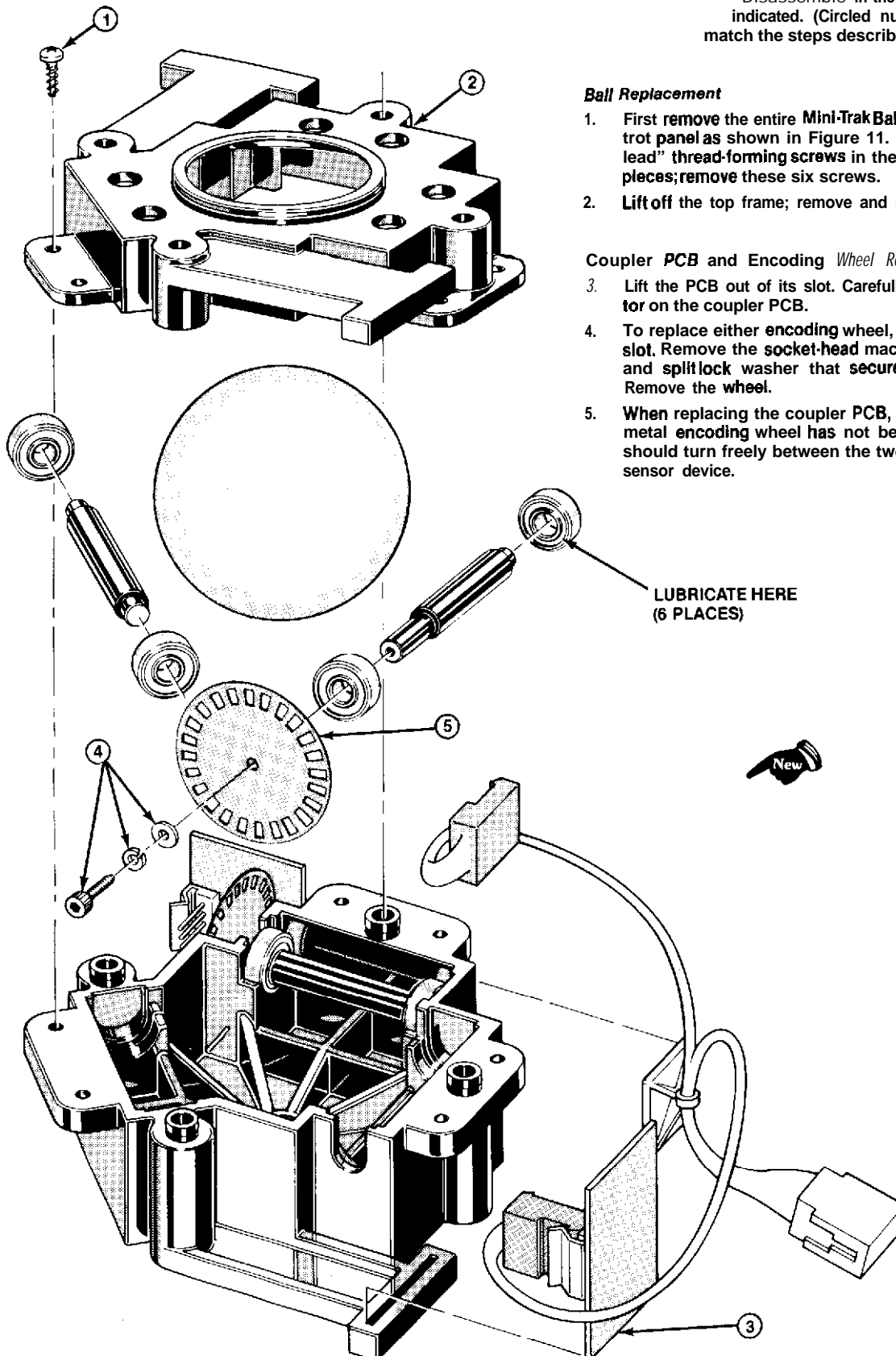

#### Ball Replacement

1. First remove the entire Mini-Trak Ball assembly from the control panel as shown in Figure 11. Now locate the six "twin-lead" thread-forming screws in the black frames or plastic pieces; remove these six screws.
2. Lift off the top frame; remove and replace the ball.

#### Coupler PCB and Encoding Wheel Replacement

3. Lift the PCB out of its slot. Carefully unplug the red connector on the coupler PCB.
4. To replace either encoding wheel, remove the PCB from its slot. Remove the socket-head machine screw, flat washer, and splitlock washer that secure the encoding wheel. Remove the wheel.
5. When replacing the coupler PCB, be certain that the black metal encoding wheel has not been bent or damaged. It should turn freely between the two halves of the red photo-sensor device.

Figure 11 Mini-Trak Ball™ Maintenance and Repair

## D. Monitor Removal

The following procedure should only be performed by a qualified service technician.

### WARNING

#### Shock Hazard

High voltages may exist in any television or monitor, even with power disconnected. Use extreme caution and do not touch electrical parts of the yoke area with your hands or with metal objects in your hands!

#### Implosion Hazard

If you drop the monitor and the picture tube breaks, it will implode! Shattered glass and the yoke can fly 6 feet or more from the implosion. Use care when replacing any monitor.

To remove the color monitor, follow steps 1 thru 6 below. Refer to the accompanying Figure 12.

1. Be sure the game is unplugged from its wall outlet! Unlock and open the rear access panel, coin door, and control panel.
2. Remove the glass monitor shield. Carefully remove the four staples that secure the blue cardboard bezel. As an extra precaution, we highly recommend you discharge the high voltage from the picture tube.
3. Standing at the rear opening of the game, locate the 2-pin and 6-pin harness connectors for the monitor. Unplug both of these.
4. At the bottom rear of the monitor chassis is a wood screw that secures rear part of the chassis. Remove this screw.
5. From the front of the cabinet, locate the flat washers, and self-locking hex nuts (two sets underneath, and two sets above the monitor screen). This hardware attaches the monitor to the cabinet. Remove this hardware.
6. Carefully pull the monitor chassis out of the cabinet towards you.

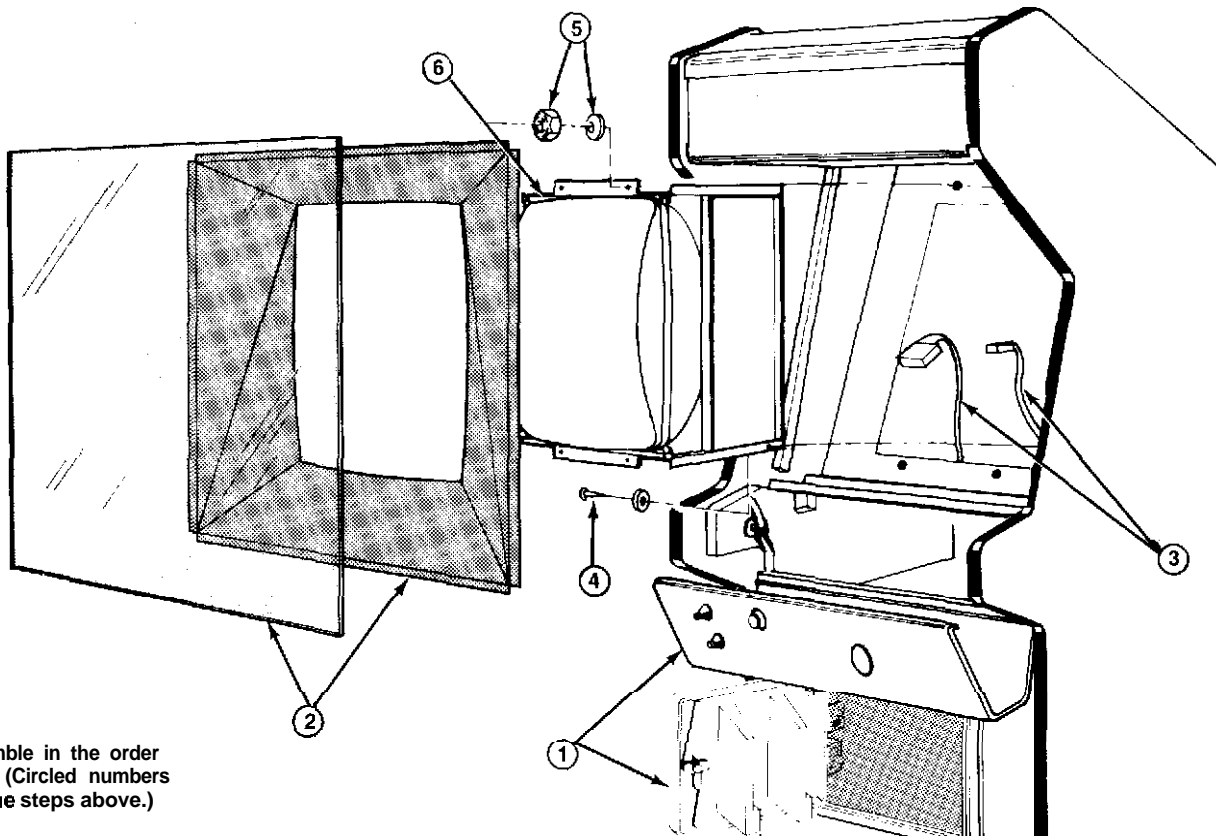

Disassemble in the order indicated. (Circled numbers match the steps above.)

Figure 12 Monitor Removal

## E. Printed-Circuit Board Removal

You may wish to remove the Centipede™ game printed circuit board (PCB) or the Regulator/Audio II PCB for service or inspection. To do this, refer to Figure 13 and proceed as follows:

### 1. Game PCB Removal

- Unlock and open the rear access panel.
- Remove the 24-pin and 44-pin edge connectors from the right side of the game PCB.
- Locate the Phillips-head screw that extends through the PCB and into the two wood blocks (at the right side of the board). Remove and save this screw, as well as the fiber spacers.
- Remove the PCB from the cabinet by carefully sliding it straight out of the plastic PCB retainer. Be careful not to twist the board, as this may loosen connections or components. Replace or repair as necessary.

- After servicing, reinstall the PCB, making sure that the edge connectors are properly plugged in. Note that the connectors are keyed to fit on only one way, so if they don't slip on easily, don't force them! A reversed connector will probably damage your PCB and will void the warranty.
- Check that the operation of the game is correct by performing the **self-test**. It is especially important to do the self-test with any game when you replace a PCB.

### 2. Regulator/Audio II PCB Removal

- Unlock and open the rear access panel.
- Remove the five plug-in connectors on the Regulator/Audio II PCB. Note that all of these connectors are keyed for proper orientation.
- Locate the two Phillips-head screws that extend through the PCB and into the wood behind the PCB. Remove and save these two screws and the two fiber spacers.
- Remove the PCB from the interior wall of the cabinet by lifting it up and out of the wood slot.

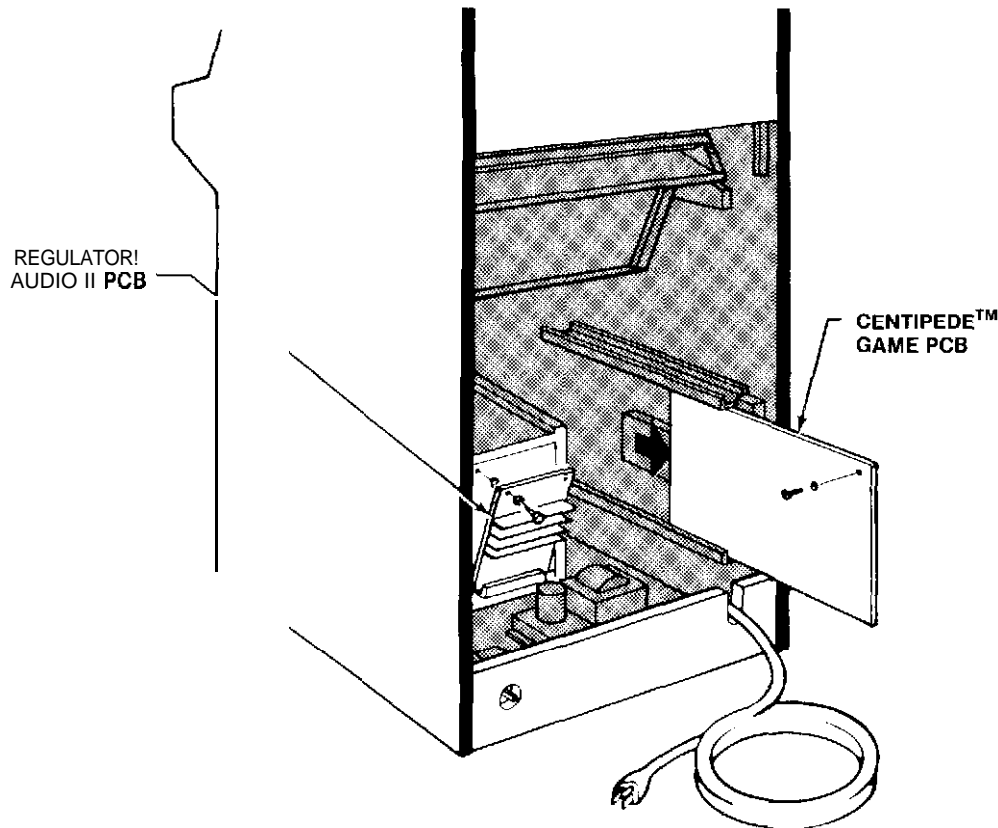

Figure 13 Printed-Circuit Board Removal

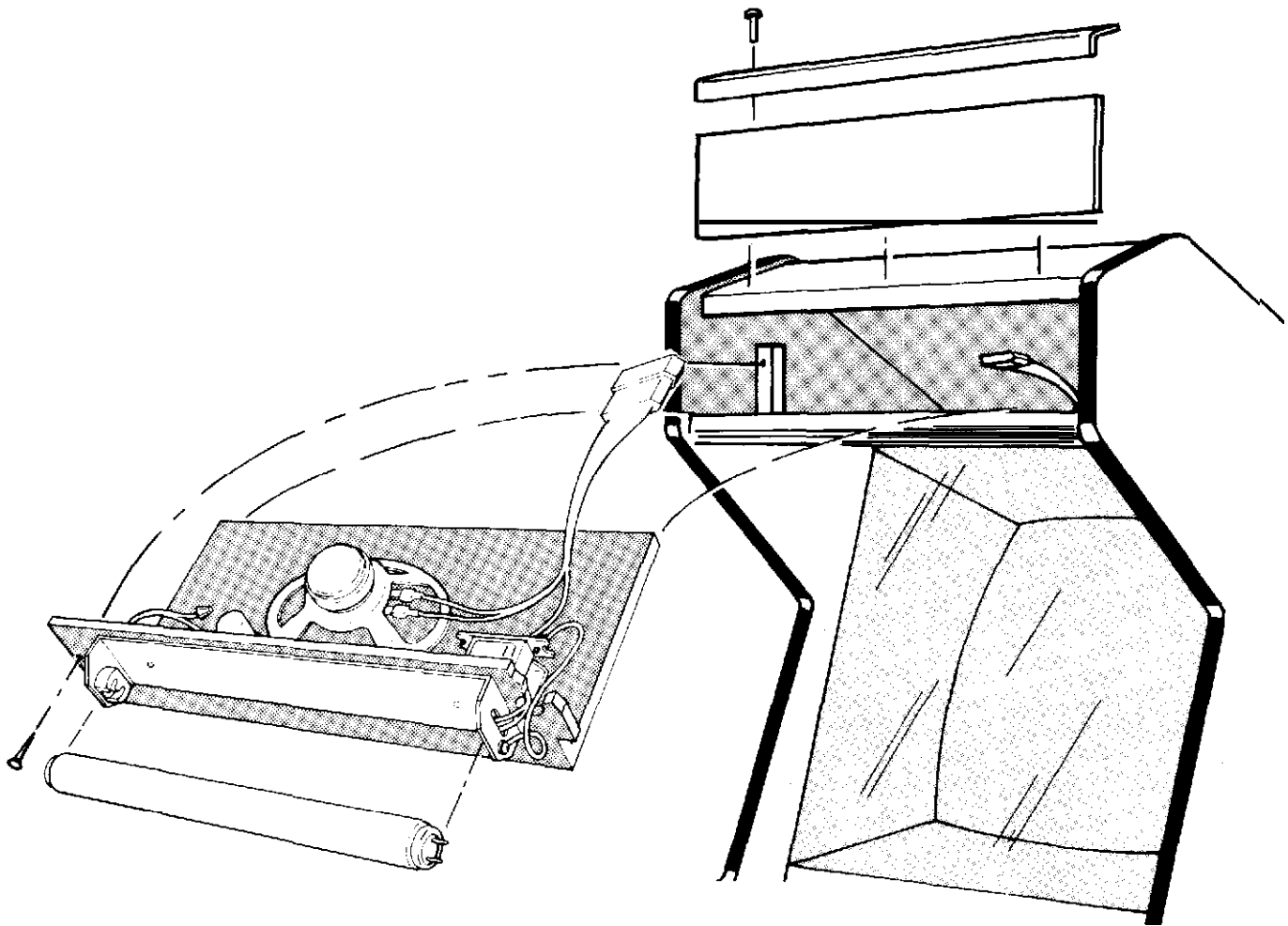

Figure 14 Fluorescent Tube Replacement

## F. Fluorescent Tube and Speaker Replacement

To replace speaker or the white fluorescent tube behind the front graphics attraction panel, follow this procedure (see Figure 14).

1. Be sure the game is unplugged from its wall outlet. Remove the three **Allen-head** screws at the top of the game (they secure the black metal retainer for the attraction panel). Lift the attraction panel up and out of its lower retainer.
2. If you need to replace the speaker, remove the two Phillips screws that secure the light board to the cabinet, and slide out the whole assembly. The fluorescent light and speaker harness has extra length, so you can pull the assembly about one foot out of the game. Unplug the harness connector just behind the board.

### ⚠ WARNING ⚠

If you drop a fluorescent tube and it breaks it will implode! Shattered glass can fly 6 feet or more from the implosion. Use care when replacing any fluorescent tube.

3. Remove the two plug-in connectors on the speaker. Remove the speaker from the wood board and replace it.
4. To replace the fluorescent tube, slightly rotate it up or down, and carefully remove it from the lampholders.
5. Replace with a new tube. Never force the tube into the **lampholders-you may break it, causing an implosion!**
6. **Also** check that the green ground wire is securely attached to the large metal bracket and the ballast transformer behind the wood panel. If the lamp is not grounded, it may not start.
7. If you removed the light and speaker assembly, reconnect the harness connector; then reinstall the assembly. Replace the attraction panel on the front of the game.



## G. Game Operation

With this manual you received two large sheets that contain the wiring and schematic diagrams for the Centipede™ (upright) game. Sheet 1, Side A, includes a "table of contents" that shows the arrangement of these diagrams. They explain the functions

of the circuits; the diagrams also define inputs and outputs.

Atari's Centipede™ is a microprocessor-controlled game. The microprocessor is mounted on the game PCB. The game PCB receives switch inputs from the control panel and coin door. These inputs are processed by the game PCB and output to the monitor, Regulator/Audio II PCB, loudspeaker, and control panel.

The Regulator/Audio II PCB performs two functions: 1) it regulates the +10 VDC from the power supply to +5 VDC, and 2) it amplifies the audio output from the game PCB. The +5 VDC from the Regulator/Audio II PCB provides most logic power to the game PCB. The audio output from the Regulator/Audio II PCB directly drives the game speaker and is controlled by the volume control, mounted on the bracket inside the coin door.



The power supply is the source of all voltages in the game. These voltages are protected by three fuses (F3, F4 and F5) on the power supply chassis. The primary winding of the power supply transformer is protected by the fuses F1 and F2 on the power-supply chassis.

Figure 15 illustrates the distribution of power in this game. Figure 16 illustrates the distribution of signals.

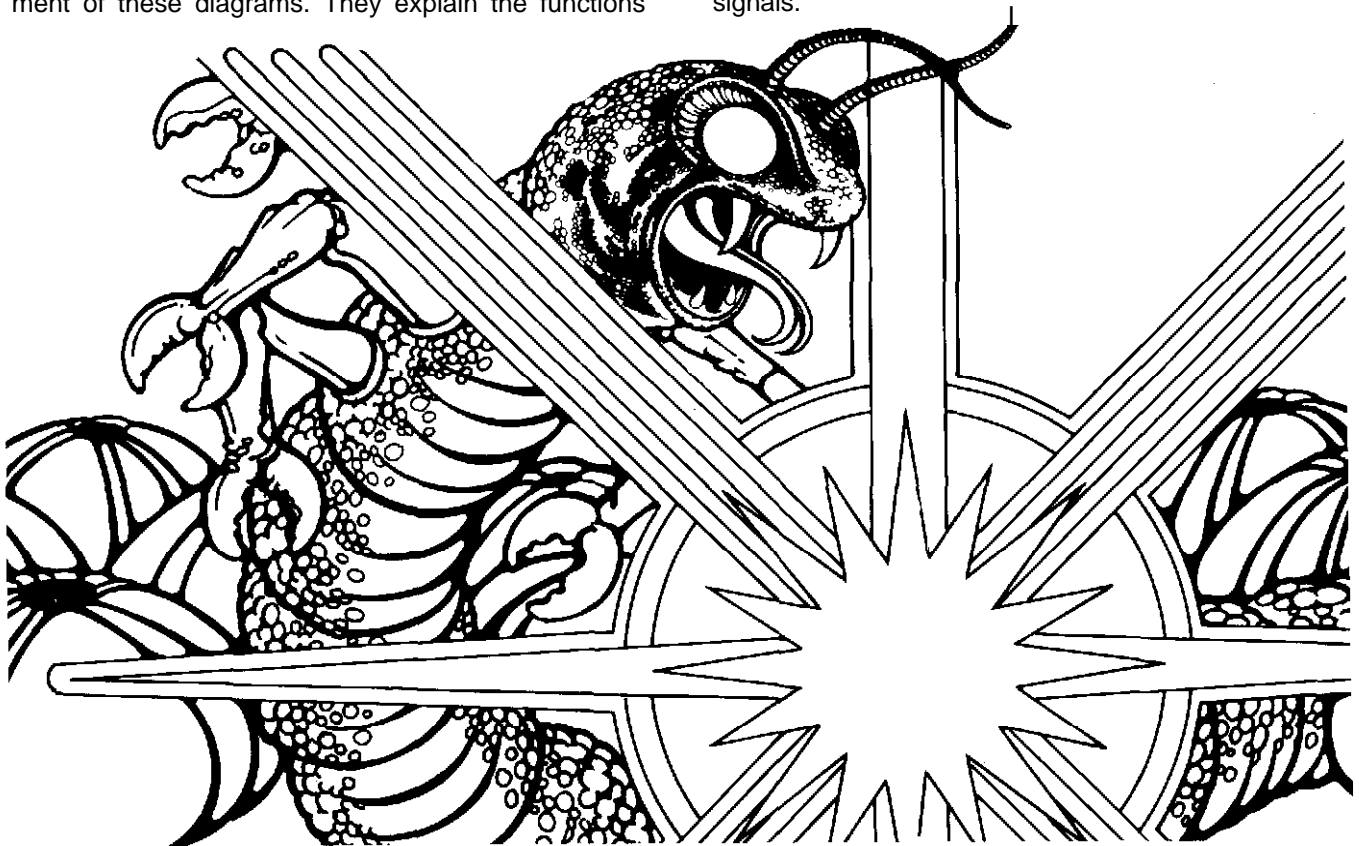

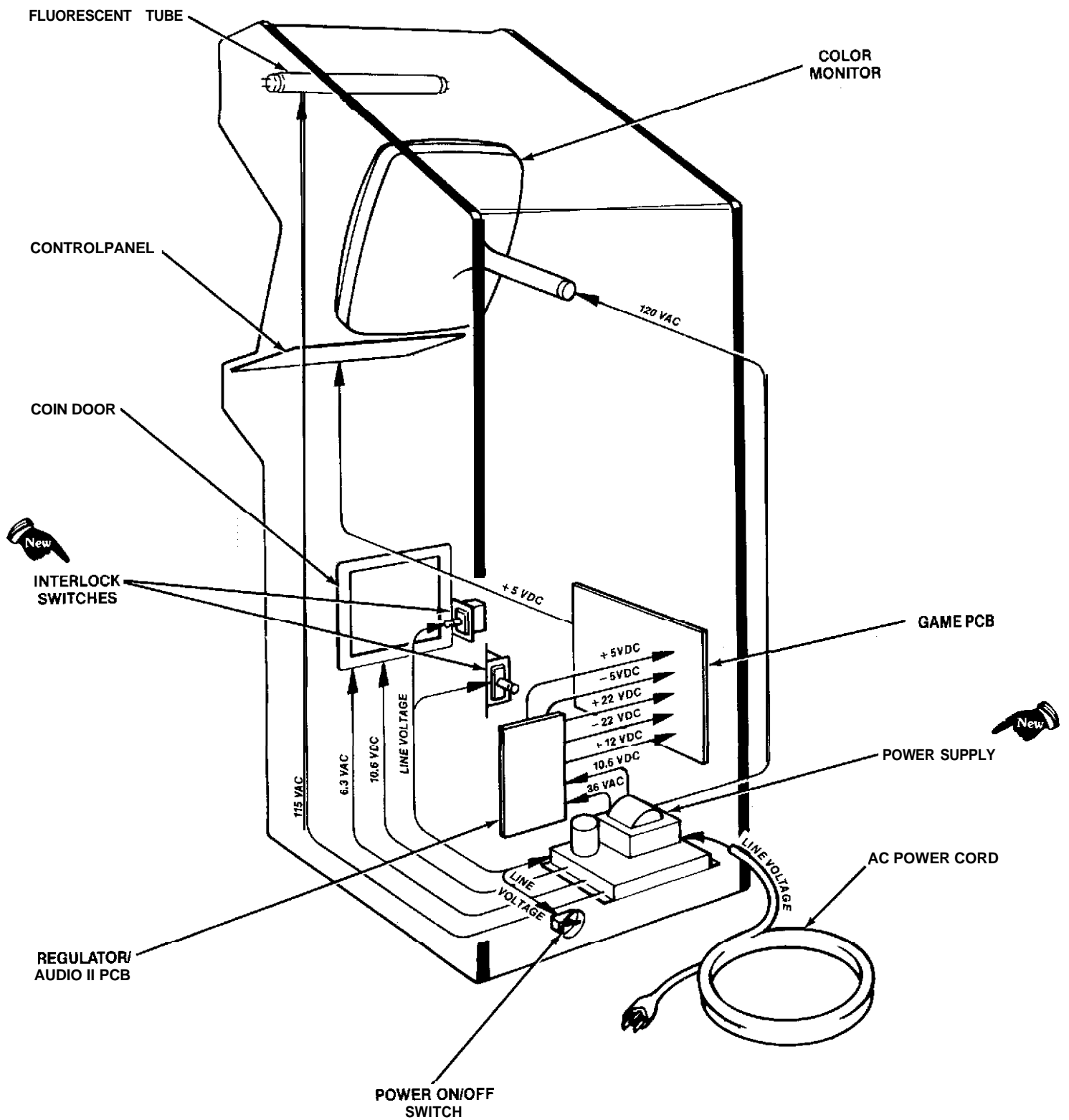

Figure 15 Power Distribution

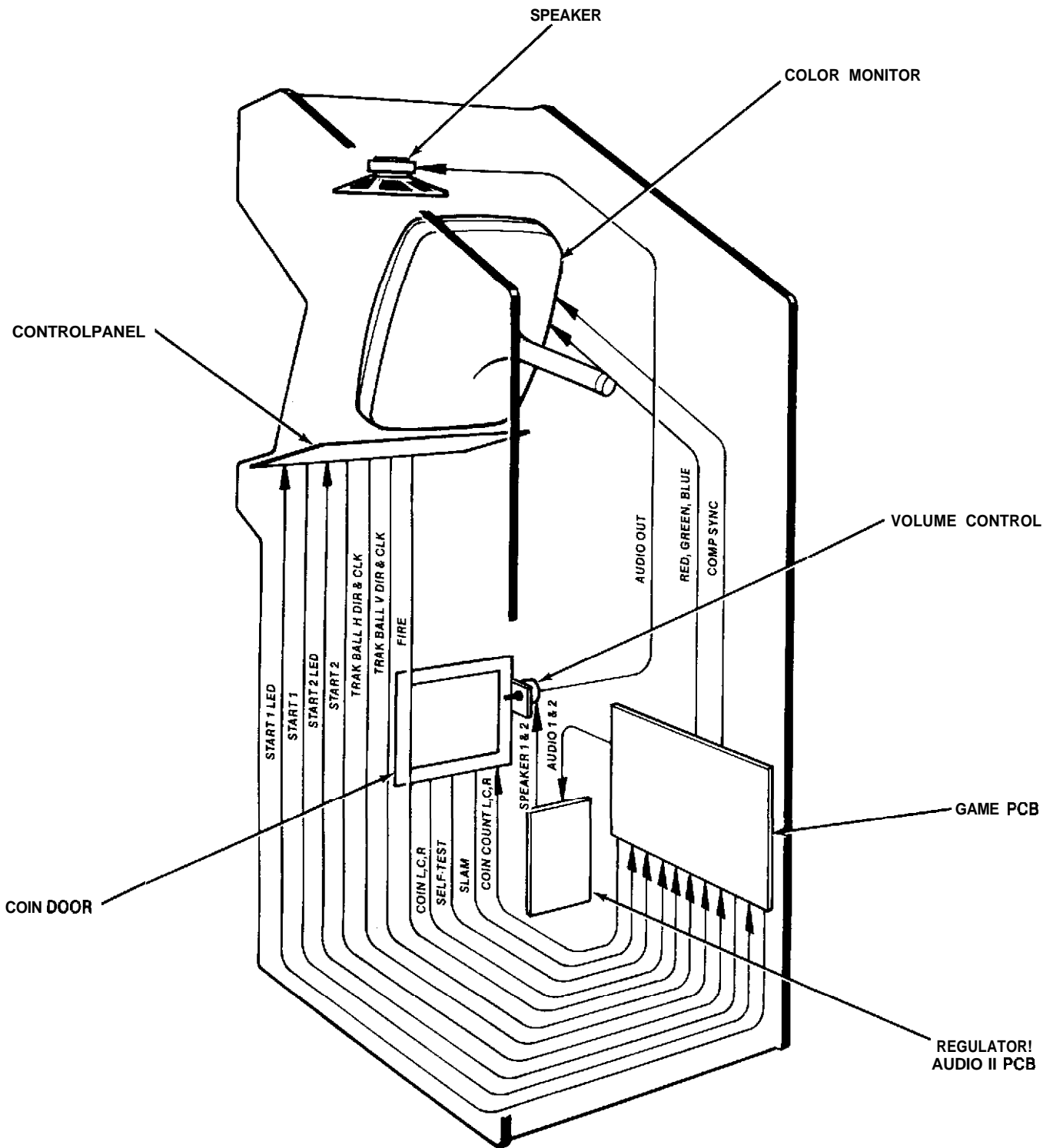

Figure 16 Signal Distribution

# Illustrated Parts Lists



This chapter provides you with the necessary information for ordering replacement parts for your Centipede™ game. Please note that, for simplicity, **common hardware has been deleted** from most of these parts lists. This includes screws, nuts, washers, bolts, etc.

The parts lists are arranged in alphanumeric order. For example, all "A." prefix numbers come first. Following this are numbers in sequence evaluated up to the hyphen, namely 00- thru 99-, then 000598-thru approximately 190000-.

When ordering parts from your distributor, give the part number, part name, applicable figure number of this manual, and serial number of your game. This will help to avoid confusion and mistakes in your order. We hope the results will be less downtime and more profit from your game.





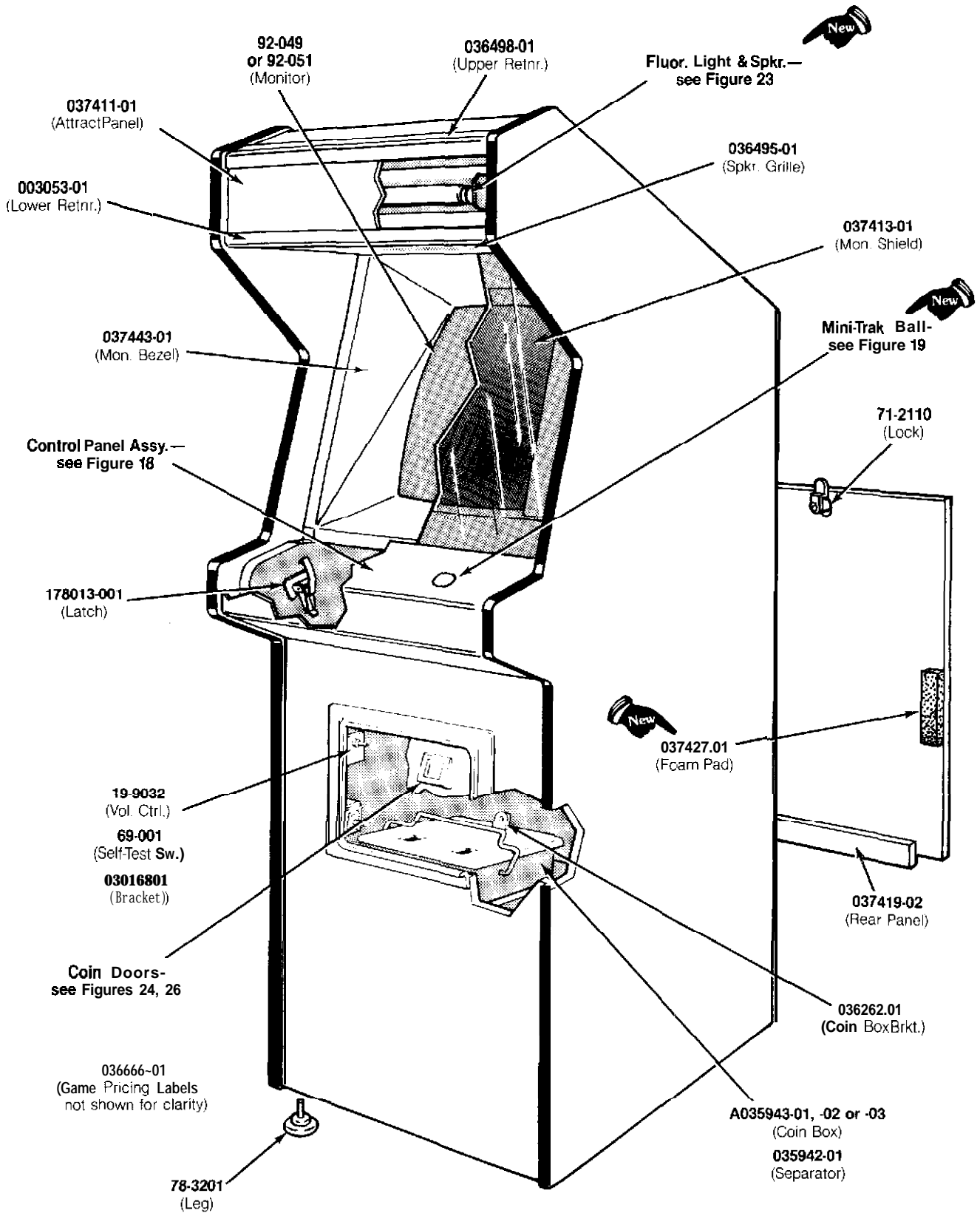
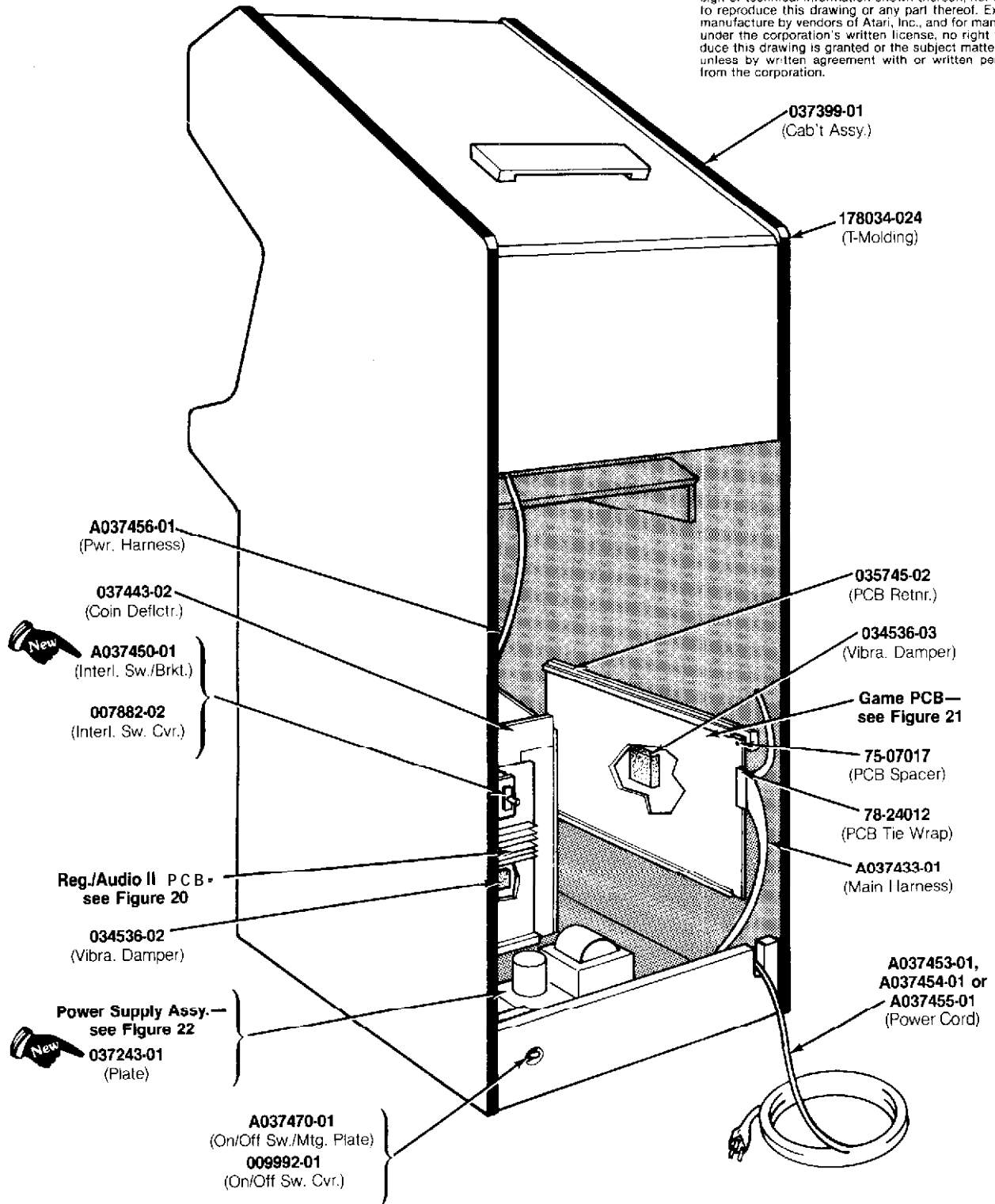

Figure 17 Cabinet-Mounted Assemblies  
A037397-xx A



Schematics, Self-Test Label & Manuals—  
see parts list on following page

**NOTICE TO ALL PERSONS RECEIVING THIS DRAWING**  
CONFIDENTIAL: Reproduction forbidden without the specific written permission of Atari, Inc., Sunnyvale, CA. This drawing is only conditionally issued, and neither receipt nor possession thereof confers or transfers any right in, or license to use, the subject matter of the drawing or any design or technical information shown thereon, nor any right to reproduce this drawing or any part thereof. Except for manufacture by vendors of Atari, Inc., and for manufacture under the corporation's written license, no right to reproduce this drawing is granted or the subject matter thereof unless by written agreement with or written permission from the corporation.



**Figure 17 Cabinet-Mounted Assemblies**  
**A037397-xx A**

## Figure 17 Cabinet-Mounted Assemblies, continued Parts List

Part No.	Description
A035943-01	Deep-Well Coin Box Assembly (for all the same coins)
A03594302	Deep-Well Coin Box Assembly (for two different coin denominations-has one separator)
A03594303	Deep-Well Coin Box Assembly (for three different coin denominations-has two separators)
A037433-01	Main Harness Assembly
A037450-01	Interlock Switch/Bracket Assembly (modified for safety) 
A037453-01	Strain-Relief Power Cord (U.S.)
A037454-01	Strain-Relief Power Cord (Austria, Belgium, Chile, Denmark, Finland, France, Germany, Greece, Indonesia, Italy, Netherlands, Norway, Spain, Sweden, and Uruguay)
A03745501	Strain-Relief Power Cord (Australia and New Zealand)
A037456-01	Power Harness Assembly
A037470-01	Power On/Off Switch/Mounting Plate Assembly
The following six items are the technical information supplements to this game:	
DP.182.01	Centipede™ (Upright) Schematic Drawings (Sheet 1)
DP-182-02	Centipede Schematic Drawings (Sheet 2)
ST-182	Centipede label with Self-Test Procedure and Option Switch Settings
TM-160	Instruction and Service Manual for 19-Inch Electrohome Color Monitor, or
TM-168	Instruction and Service Manual for 19-Inch Wells-Gardner Color Monitor
TM-182	Centipede Operation, Maintenance and Service Manual
19-9032	Volume Control
69.001	DPDT Self-Test Switch (for British-made coin doors)
71-2110	Panel Cartridge Lock Mechanism (for rear access panel)
75.07017	Spacer for Mounting Printed Circuit Boards
78.24012	5-Inch Beaded Nylon Tie Wrap (for game PCB edge connectors)
78-3201	Cabinet-Leveling Leg
78.6900402	Vinyl Foam Single-Coated-Adhesive Tape, 1/8-Inch Thick x 1/4-Inch Wide (2 x 24 in. req'd.)
92.049	19-Inch Electrohome Color Raster-Scan Monitor, or
92.051	19-Inch Wells-Gardner Color Raster-Scan Monitor
00305301	Lower Attraction-Panel Retainer
007882.02	Interlock Switch Cover
009992-01	On/Off Switch Cover
030168-01	Volume Control Mounting Bracket (also holds self-test switch in games with British-made coin doors)
034536.02	Foam Vibration Damper (for Regulator/Audio II PCB)
034536-03	Foam Vibration Damper (for Centipede game PCB)
035745.02	18-Inch Plastic PCB Retainer
035942.01	Deep-Well Coin Box Separator
036262-01	Coin Box Bracket
036495.01	Speaker Grille
036498-01	Upper Attraction-Panel Retainer
036686-01	Card of Game Pricing Labels
037243.01	Metal Base Plate (located underneath power supply) 
037399.01	Cabinet Assembly (includes legs and PCB retainers, but not the rear access panel)
03741 I-01	Attraction Panel with Graphics
037413-01	Monitor Shield with Graphics
037419.02	Rear Access Panel (does not include lock)
037427-01	Rear Access Panel Foam Pad 
03744301	Blue Cardboard Monitor Bezel
037443.02	Cardboard Coin Deflector
178013-001	Spring Draw Latch
178034024	3/4-Inch Black Plastic T-Molding

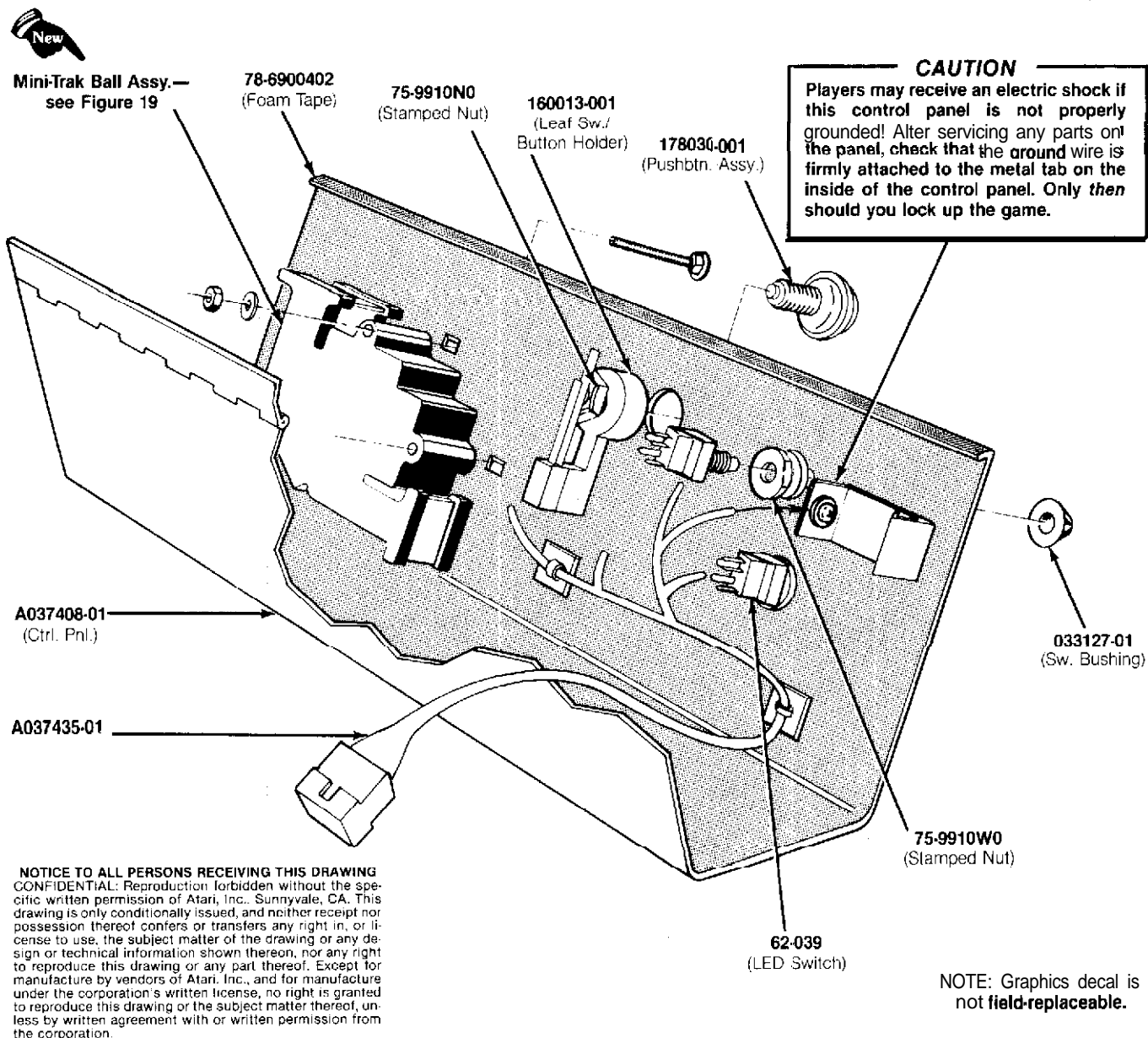
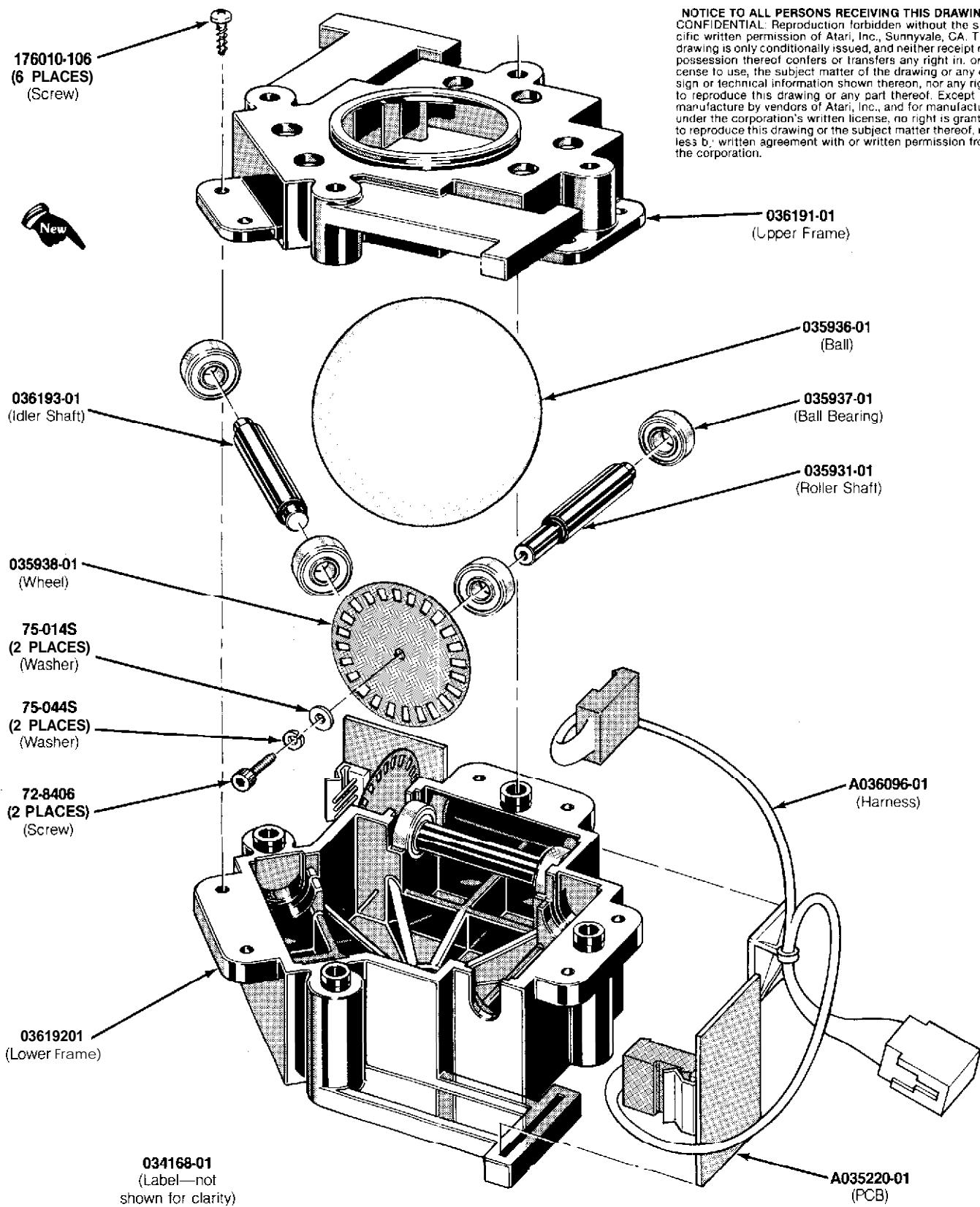

**Figure 18 Control Panel Assembly**  
**A037409-01 A**

**Parts List**

Part No.	Description
A037408-01	Control Panel with Graphics
A03743501	Control-Panel Harness
62-039	SPDT Momentary-Contact Pushbutton Start Switch with Red Light-Emitting Diode
75-9910N0	#5/8-11 Steel Stamped Nut
75-9910W0	#1 1/32-32 Steel Stamped Nut
78.6900402	Vinyl Foam Single-Coated-Adhesive Tape, 1/4-Inch wide x 3/16-Inch thick (24 in. required)
033127-01	Black Molded Switch Bushing
160013001	Leaf Switch and Button Holder (leaf switch only is part no. 160012-001)
178030-001	Pushbutton Assembly

**NOTICE TO ALL PERSONS RECEIVING THIS DRAWING**  
**CONFIDENTIAL.** Reproduction forbidden without the specific written permission of Atari, Inc., Sunnyvale, CA. This drawing is only conditionally issued, and neither receipt nor possession thereof confers or transfers any right in, or license to use, the subject matter of the drawing or any design or technical information shown thereon, nor any right to reproduce this drawing or any part thereof. Except for manufacture by vendors of Atari, Inc., and for manufacture under the corporation's written license, no right is granted to reproduce this drawing or the subject matter thereof, unless by written agreement with or written permission from the corporation.



**Figure 19 Mini-Trak Ball™ Assembly**  
**A0361 90-01 A**

## Figure 19 Mini-Trak Ball™ Assembly Parts List



<i>Part No.</i>	<i>Description</i>
A035220-01	Coupler PCB Assembly
A036096-01	Harness Assembly
72-8406	#4-40 x 3/8 Inch Hex Socket-Head Cap Alloy Steel Machine Screw
75-014s	#4 Flat Plain SAE-Standard Zinc-Plated Steel Washer
75-044s	#4 Zinc-Plated Steel Split Lock Washer
03416801	Label with Lubrication Instructions
035931-01	Roller Shaft (2 per assembly)
035936.01	Mini-Trak Ball™
03593701	Ball Bearing (6 per assembly)
03593801	Etched Encoding Wheel
036191-01	Upper Black Plastic Frame
036192-01	Lower Black Plastic Frame
036193.01	Idler Shaft (1 per assembly)
176010-106	#8 x 3/8 Inch Cross-Recessed Pan-Head Thread-Forming Twin-Lead Zinc-Plated Steel Screw

**NOTICE TO ALL PERSONS RECEIVING THIS DRAWING**  
**CONFIDENTIAL:** Reproduction forbidden without the specific written permission of Atari, Inc., Sunnyvale, CA. This drawing is only conditionally issued, and neither receipt nor possession thereof confers or transfers any right, in, or license to use, the subject matter of the drawing or any design or technical information shown thereon, nor any right to reproduce this drawing or any part thereof. Except for manufacture by vendors of Atari, Inc., and for manufacture under the corporation's written license, no right is granted to reproduce this drawing or the subject matter thereof, unless by written agreement with or written permission from the corporation.

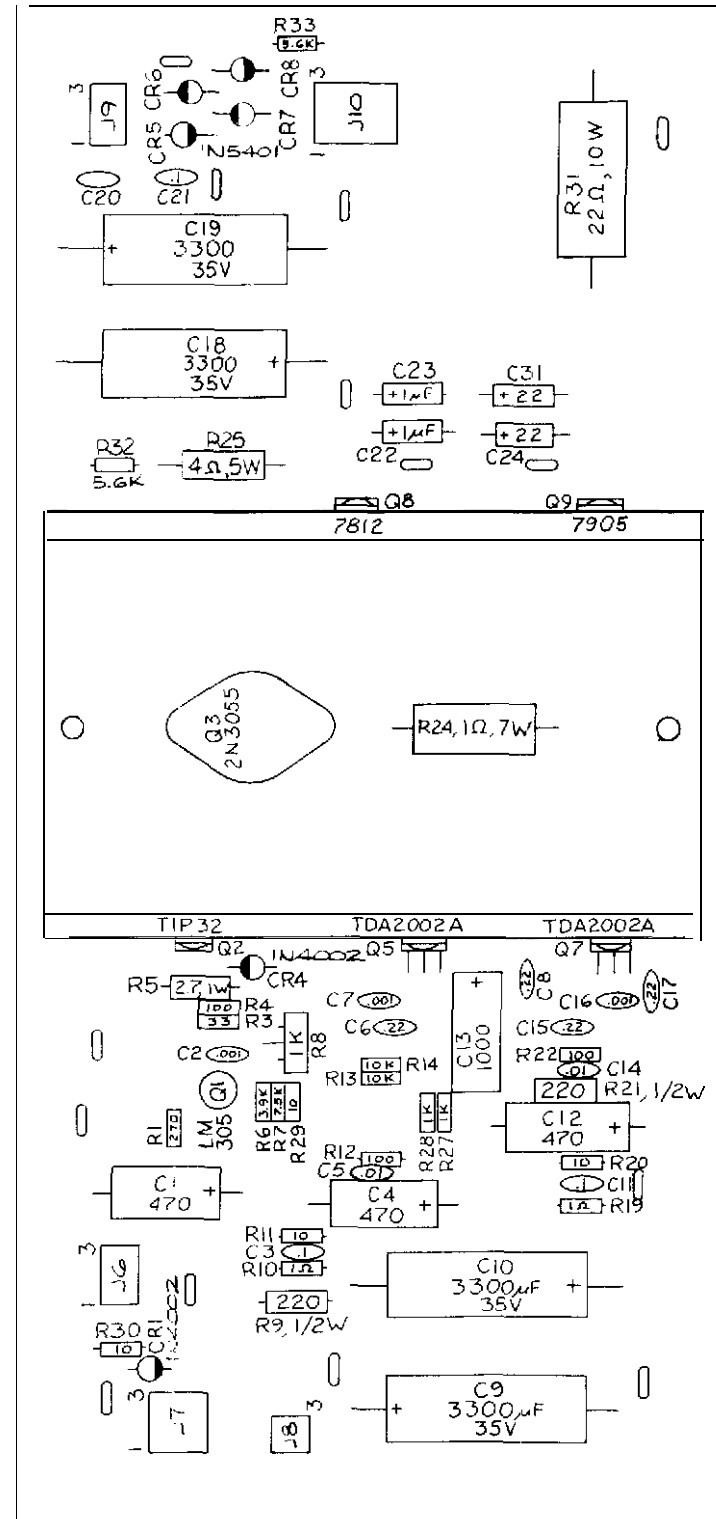
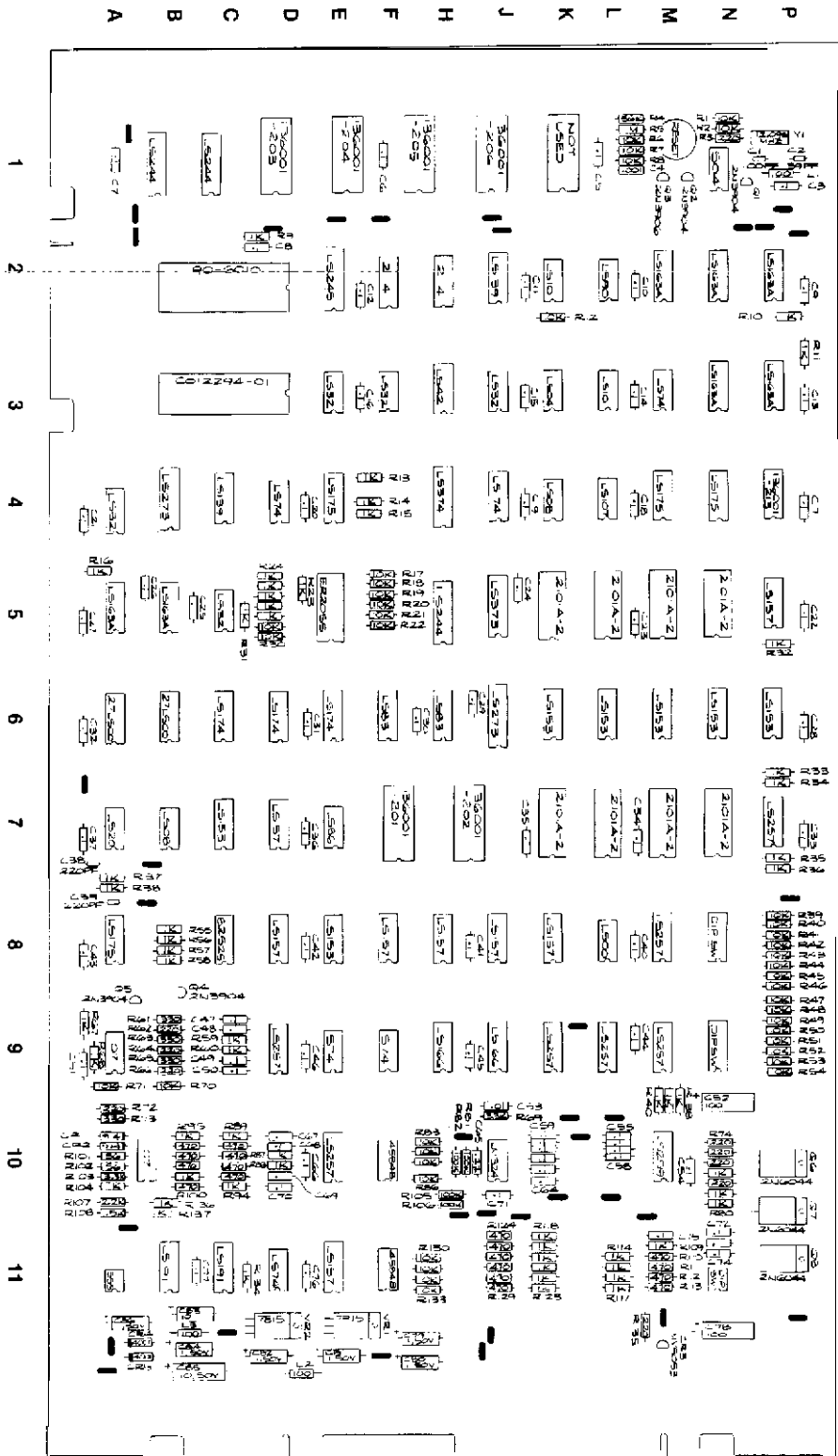

**Figure 20 Regulator/Audio II PCB Assembly  
 A03543502 D**

## Figure 20 Regulator/Audio II PCB Assembly Parts List

Part No.	Description (Reference Designations and Locations in Bold)
12-52P7	2.7 Ohm, $\pm 5\%$ , 1W Resistor (R5)
16-54PO	4 Ohm, $\pm 5\%$ , 5W Wirewound Resistor (R25)
19-100P1015	.1 Ohm, $\pm 3\%$ , 7W Wirewound Resistor (R24)
19315102	1K Ohm Vertical PCB-Mounting Cermet Trimpot (R8)
24-250108	1000 $\mu$ f Aluminum Electrolytic Fixed Axial-Lead 25V Capacitor (C13)
24.250477	470 $\mu$ f Aluminum Electrolytic Fixed Axial-Lead 25V Capacitor (C1, 4, 12)
24-350226	22 $\mu$ f Aluminum Electrolytic Fixed Axial-Lead 35V Capacitor (C24, 31)
24-350338	3300 $\mu$ f Aluminum Electrolytic Fixed Axial-Lead 35V Capacitor (C9, 10, 18, 19)
24.500105	1 $\mu$ f Aluminum Electrolytic Fixed Axial-Lead 50V Capacitor (C22, 23)
29-088	.1 $\mu$ f Ceramic-Disc 25V Radial-Lead Capacitor (C3, 11, 20, 21)
31-1N4002	100V 1-Amp. Silicon Rectifier Type 1N4002 Diode (CR1, 4-8)
31-5401	100V 3-Amp. Silicon Rectifier Type 1N5401 Diode (CR 5-8)
33-TI P32	PNP Power Transistor, Type TIP32 (Q2)
34-2N3055	NPN Silicon Transistor, Type 2N3055 (Q3)
37-LM305	5V Linear Voltage Regulator (Q1)
37-7812	+12V Voltage Regulator, Type 7812 (Q8)
37.7905	-5V Voltage Regulator, Type 7905 (Q9)
72-1608C	#6-32 $\times$ 1/2-Inch Cross-Recessed Pan-Head Corrosion-Resistant Steel Machine Screw
75-F60405	#6-32 $\times$ 1/4-Inch Binder-Head Nylon Screw
75.99516	#6-32 Nut/Washer Assembly
78-16008	Thermally Conductive Compound (Q3)
78-16014	Thermally Conductive Silicon Insulator (Q2, 9)
79-58306	6-Position Connector Receptacle (J6, 9)
79-58308	9-Position Connector Receptacle (J7)
79.58346	12-Position Connector Receptacle (J10)
7458354	4-Position Connector Receptacle (J8)
020670.01	Test Point
034531.01	Heat Sink
100015-103	.01 $\mu$ f Ceramic-Disc 25V Radial-Lead Capacitor (C5, C14)
110000-010	1 Ohm, $\pm 5\%$ , 1/4W Resistor (R10, 19)
110000-100	10 Ohm, $\pm 5\%$ , 1/4W Resistor (R11, 20, 29, 30)
110000-101	100 Ohm, $\pm 5\%$ , 1/4W Resistor (R4, 12, 22)
110000-102	1K Ohm, $\pm 5\%$ , 1/4W Resistor (R27, 28)
110000-103	10K Ohm, $\pm 5\%$ , 1/4W Resistor (R13, 14)
110000-271	270 Ohm, $\pm 5\%$ , 1/4W Resistor (R1)
110000-330	33 Ohm, $\pm 5\%$ , 1/4W Resistor (R3)
110000-392	3.9K Ohm, $\pm 5\%$ , 1/4W Resistor (R6)
110000-562	5.6K Ohm, $\pm 5\%$ , 1/4W Resistor (R32, 33)
110000.752	7.5K Ohm, $\pm 5\%$ , 1/4W Resistor (R7)
110001221	220 Ohm, $\pm 5\%$ , 1/2W Resistor (R9, 21)
116000220	22 Ohm, $\pm 5\%$ , 10W Wirewound Resistor (R31)
122002-102	.001 $\mu$ f Ceramic-Disc Minimum 25V Radial-Lead Capacitor (C2, 7, 16)
122004.224	.22 $\mu$ f Ceramic-Disc 25V Capacitor (C6, 8, 15, 17)
137151-002	Type TDA2002A 8W Linear Audio Amplifier Integrated Circuit (Q5, 7)





**NOTICE TO ALL PERSONS RECEIVING THIS DRAWING**  
 CONFIDENTIAL. Reproduction, for or without the specific written permission of Atari, Inc., Sunnyvale, CA. This drawing is only conditionally issued, and neither receipt nor possession thereof confers or transfers any right in, or license to use, the subject matter of the drawing, or any design or technical information shown thereon, nor any right to reproduce this drawing or any part thereof. Except for manufacture by vendors of Atari, Inc., and for manufacture under the corporation's written license, no right is granted to reproduce this drawing or the subject matter thereof, unless by written agreement with or written permission from the corporation.

Figure 21 Centipede™ Game PCB Assembly  
 A037241 -01 B

## Figure 21 Centipede™ Game PCB Assembly, continued Parts List

Part No.	<i>Description (Reference Designations and Locations in Bold)</i>
C012294-01	Audio I/O N-Channel MOS/LSI Custom Chip <b>(C3)</b>
24-250 106	10uf Aluminum Electrolytic Fixed Axial-Lead 25V Capacitor (C83)
24.250107	100 uf Aluminum Electrolytic Fixed Axial-Lead 25V Capacitor <b>(C52, 78)</b>
24-500105	1 mf Aluminum Electrolytic Fixed Axial-Lead 50V Capacitor <b>(C79-82, 84, 86)</b>
24.500106	10uf Aluminum Electrolytic Fixed Axial-Lead 50V Capacitor <b>(C85)</b>
29-088	.1uf Ceramic-Disc 25V Radial-Lead Capacitor <b>(C3, 5-37, 40-51, 54-64, 66-77)</b>
31-1N914	75V Type-1N914 Switching Diode <b>(CR1, 2)</b>
31-1N4001	75V Type-1N4001 Switching Diode <b>(CR4, 5)</b>
33-2N3906	Type-2N3906 PNP Switching and Amplifying Transistor <b>(Q3)</b>
34-2N3904	Type-2N3904 NPN Silicon Transistor <b>(Q1, 2, 4, 5)</b>
34-2N6044	Type-2N6044 Darlington NPN Transistor <b>(Q6-8)</b>
37-LM324	Type-LM324 Integrated Circuit <b>(J10)</b>
37-4584B	Type-4584B Integrated Circuit <b>(F10, F11)</b>
37.555	Type-555 Timer Integrated Circuit (All)
37-74LS00	Type-74LS00 Integrated Circuit <b>(L8)</b>
37-74LS04	Type-74LS04 Integrated Circuit <b>(K3)</b>
37-74LS08	Type-74LS08 Integrated Circuit (87, <b>K4)</b>
37-74LS10	Type-74LS10 Integrated Circuit (L3, K2)
37-74LS20	Type-74LS20 Integrated Circuit <b>(A7)</b>
37-74LS32	Type-74LS32 Integrated Circuit <b>(A4, C5, E3, F3, J3)</b>
37-74LS42	Type-74LS42 Integrated Circuit (H3)
37-74LS74	Type-74LS74 Integrated Circuit <b>(D4, D11, M3)</b>
37-74LS83	Type-74LS83 Integrated Circuit <b>(F6, H6)</b>
37-74LS86	Type-74LS86 Integrated Circuit <b>(E7)</b>
37-74LS90	Type-74LS90 Integrated Circuit <b>(L2)</b>
37-74LS139	Type-74LS139 Integrated Circuit <b>(C4, J2)</b>
37-74LS153	Type-74LS153 Integrated Circuit <b>(C7, E8, K6, L6, M6, N6, P6)</b>
37-74LS157	Type-74LS157 Integrated Circuit <b>(D7, D8, E11, F8, H8, J8, K8, P5)</b>
37-74LS163A	Type-74LS163A Integrated Circuit (b.5, <b>B5, M2, N2, N3, P2, P3)</b>
37-74LS166	Type-74LS166 Integrated Circuit <b>(H9, J9)</b>
37-74LS174	Type-74LS174 Integrated Circuit <b>(C6, D6, E6, J4)</b>
37-74LS175	Type-74LS175 Integrated Circuit <b>(A8, E4, M4, N4)</b>
37-74LS191	Type-74LS191 Integrated Circuit <b>(B11, C11)</b>
37-74LS244	Type-74LS244 Integrated Circuit <b>(B1, Cl. H5)</b>
37-74LS245	Type-74LS245 Integrated Circuit <b>(E2)</b>
37-74LS257	Type-74LS257 Integrated Circuit <b>(D9, E10, K9, L9, P7, M8, M9)</b>
37-74LS259	Type-74LS259 Integrated Circuit <b>(M10)</b>
37-74LS273	Type-74LS273 Integrated Circuit <b>(B4, J6)</b>
37-74LS373	Type-74LS373 Integrated Circuit <b>(J5)</b>
37-74LS374	Type-74LS374 Integrated Circuit <b>(H4)</b>
37-74S04	Type-74S04 Integrated Circuit <b>(N1)</b>
37-74S74	Type-74S74 Integrated Circuit <b>(E9, F9)</b>
37.7407	Type-7407 Integrated Circuit <b>(A9, A/B10)</b>
37-7815	+ 15V Voltage Regulator <b>(VR2)</b>
37-7915	-15V Voltage Regulator <b>(VR1)</b>
38-MV5053	Type-MV5053 Light-Emitting Diode <b>(CR3)</b>

[Continued on next page]

## Figure 21 Centipede™ Game PCB Assembly, continued Parts List

Part No.	Description (Reference Designations and Locations in Bold)
41-3003	100 $\mu$ H, $\pm 5\%$ , Hot-Molded Plastic Fixed R.F. Choke <b>(L1-3)</b>
62-001	SPST Momentary Pushbutton Switch (Reset)
66-114P1T	4-Station, Single-Throw, Dual-Inline-Package Bit Switch <b>(N11)</b>
66-118P1T	&Station, Single-Throw, Dual-Inline-Package Bit Switch <b>(N8, N9)</b>
79-42C16	16-Contact Medium-Insertion-Force Integrated Circuit Socket <b>(P4)</b>
79-42C22	22-Contact Medium-Insertion-Force Integrated Circuit Socket <b>(E5)</b>
79-42C24	24-Contact Medium-Insertion-Force Integrated Circuit Socket <b>(F7, H/J7, D1, E1, F/H1, J1)</b>
79-42C40	40-Contact Medium-Insertion-Force Integrated Circuit Socket <b>(C2, C3)</b>
61.4302	Nylon Snap-In Fastener
90-102	12.096, $\pm .005\%$ , Crystal <b>(Y1)</b>
90-6010	Microprocessor <b>(C2)</b>
90-7005	Random-Access Memory <b>(C8)</b>
907018	Random-Access Memory <b>(K5, K7, L5, L7, M5, M7, N5, N7)</b>
907033	Random-Access Memory <b>(F2, H2)</b>
020670.01	Test Point
110000-102	1K Ohm, $\pm 5\%$ , $\frac{1}{4}$ W Resistor <b>(R9-11, 13-16, 23-28, 31-38, 55-60, 67, 68, 77, 79, 80, 87-89, 94, 95, 99, 104, 109, 114-123, 134, 136-140)</b>
110000-103	10K Ohm, $\pm 5\%$ , $\frac{1}{4}$ W Resistor <b>(R1, 2, 6-8, 12, 17-22, 29, 30, 39-54, 70, 71, 83-86, 130-133)</b>
110000-104	110K Ohm, $\pm 5\%$ , $\frac{1}{4}$ W Resistor <b>(R81, 82, 105, 106)</b>
110000-105	100 MegOhm, $\pm 5\%$ , $\frac{1}{4}$ W Resistor <b>(R5)</b>
110000-152	1.5K Ohm, $\pm 5\%$ , $\frac{1}{4}$ W Resistor <b>(R108)</b>
110000-221	220 Ohm, $\pm 5\%$ , $\frac{1}{4}$ W Resistor <b>(R3, 62, 64, 66, 72, 74-76, 78, 135)</b>
110000.222	2.2K Ohm, $\pm 5\%$ , $\frac{1}{4}$ W Resistor <b>(R107)</b>
110000-331	330 Ohm, $\pm 5\%$ , $\frac{1}{4}$ W Resistor <b>(R61, 63, 65, 73)</b>
110000-332	3.3K Ohm, $\pm 5\%$ , $\frac{1}{4}$ W Resistor <b>(R69, 103)</b>
110000-471	470 Ohm, $\pm 5\%$ , $\frac{1}{4}$ W Resistor <b>(R90-93, 96-98, 100, 110-113, 124-129)</b>
110000-560	56 Ohm, $\pm 5\%$ , $\frac{1}{4}$ W Resistor <b>(R101, 102)</b>
110000-563	56K Ohm, $\pm 5\%$ , $\frac{1}{4}$ W Resistor <b>(R4)</b>
122002-102	.001 $\mu$ f Ceramic-Disc 50V Radial-Lead Capacitor <b>(C4)</b>
122004.224	.22 $\mu$ f Ceramic-Disc 25V Radial-Lead Capacitor <b>(C65)</b>
122005-103	.01 $\mu$ f Ceramic-Disc 25V Radial-Lead Capacitor <b>(C53)</b>
128002-101	100 pf Radial-Lead Epoxy-Dipped 100V Mica Capacitor <b>(C1)</b>
128002-221	220 pf Radial-Lead Epoxy-Dipped 100V Mica Capacitor <b>(C38, 39)</b>
126002.390	39 pf Radial-Lead Epoxy-Dipped 100V Mica Capacitor <b>(C2)</b>
136001-201 or -211	Read-Only Memory <b>(F7)</b>
136001-202 or -212	Read-Only Memory <b>(H/J7)</b>
136001-203 or -207	Read-Only Memory <b>(D1)</b>
136001.204 or -208	Read-Only Memory <b>(E1)</b>
1X031-205 or -209	Read-Only Memory <b>(F/H1)</b>
136001-206 or -210	Read-Only Memory <b>(J1)</b>
136001-213	Programmable Read-Only Memory <b>(P4)</b>
137161-001	Type-ER2055 Integrated Circuit <b>(E5)</b> Note: If you replace this part, <b>you</b> must erase this ROM before locking up the game. See Figure 6, Self-Test Procedure, in this manual for instructions.
137164001	Type-74LS107 Integrated Circuit <b>(L4)</b>
137170-001	Random-Access Memory <b>(A6, B6)</b> Acceptable substitute is part no. 90-7008 or 90-7035.

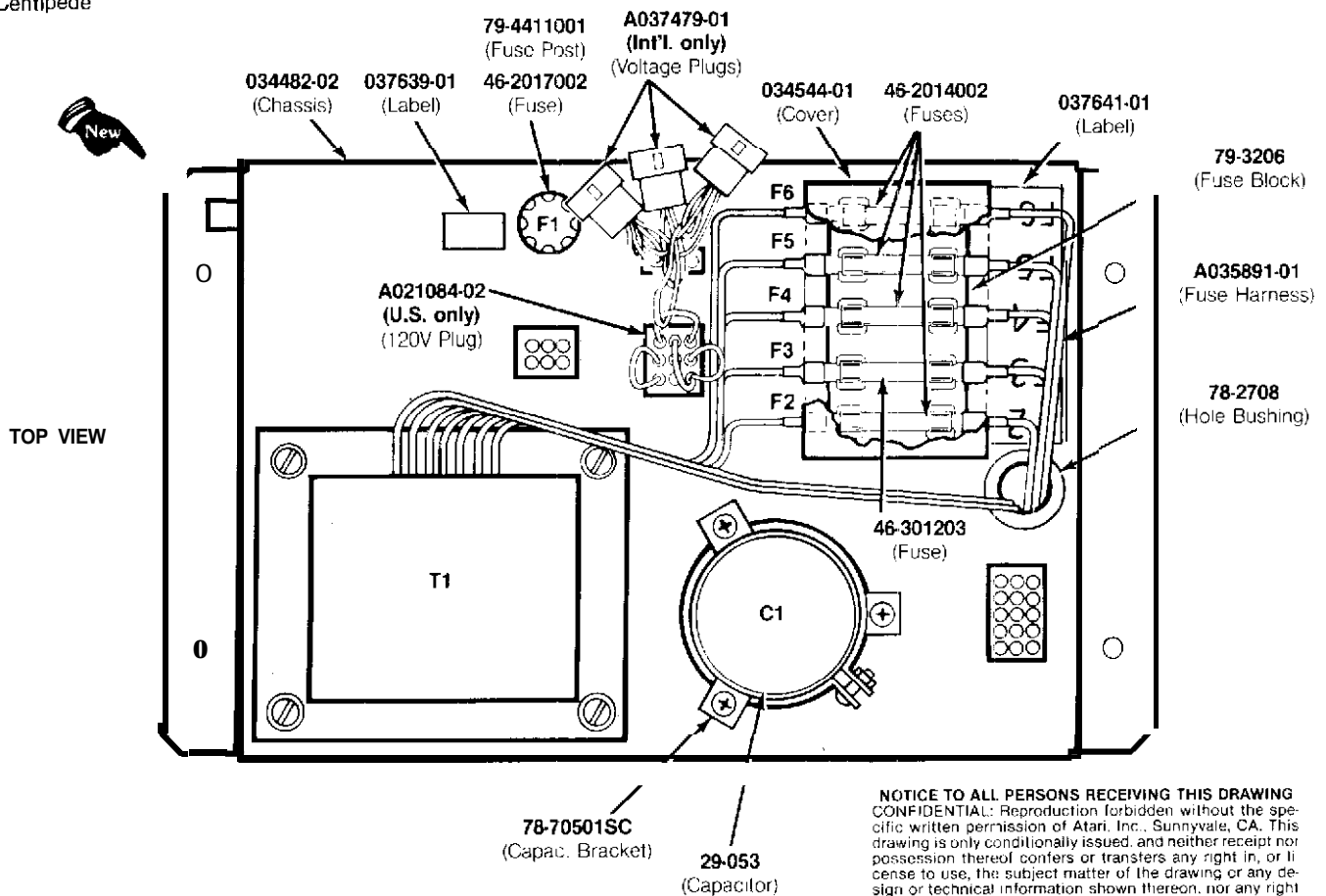

**NOTICE TO ALL PERSONS RECEIVING THIS DRAWING**  
 CONFIDENTIAL: Reproduction forbidden without the specific written permission of Atari, Inc., Sunnyvale, CA. This drawing is only conditionally issued, and neither receipt nor possession thereof confers or transfers any right in, or license to use, the subject matter of the drawing or any design or technical information shown thereon, nor any right to reproduce this drawing or any part thereof. Except for manufacture by vendors of Atari, Inc., and for manufacture under the corporation's written license, no right is granted to reproduce this drawing or the subject matter thereof, unless by written agreement with or written permission from the corporation.

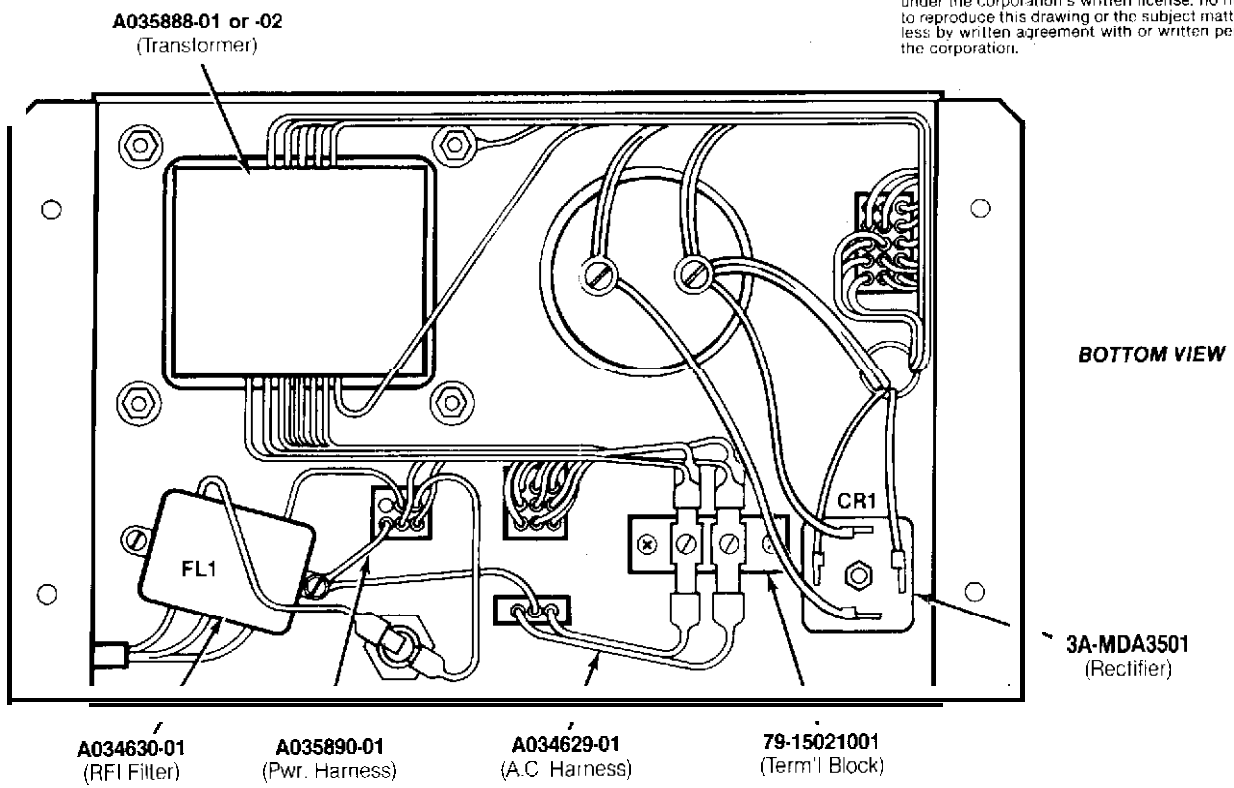

**Figure 22 Power Supply Assembly**  
**A037671-01 (U.S.) A / A037671-02 (International) A**

## Figure 22 Power Supply Assembly Parts List



Part No.	<i>Description (Reference Designations in Bold)</i>
A021084-02	Voltage Plug (120V plug—for U.S. power supply only)
A03462901	A.C. Harness Assembly
A034630-01	RFI Filter Assembly <b>(FL1)</b>
A035888-01 or -02	Transformer Assembly <b>(T1)</b>
A035690-01	Power Harness Assembly
A035691-01	Fuse Harness Assembly
A037479-01	Voltage Plug Assembly (100V, 220V and 240V plugs--international only)
29.053	27,000 uf 15 VDC Electrolytic Capacitor (C1)
3A-MDA3501	Bridge Rectifier, Type MDA 3501 <b>(CR1)</b>
46-2014002	4-Amp. 250 V 3AG Slow-Blow Glass Cartridge-Type Fuse <b>(F2, F4-F6)</b>
46-2017002	7-Amp. 250 V 3AG Slow-Blow Glass Cartridge-Type Fuse <b>(F1)</b>
46-301203	20-Amp. 32 V 3AG Slow-Blow Glass Cartridge-Type Fuse <b>(F3)</b>
78-2708	Nylon Type 616 Hole Bushing with $\frac{5}{8}$ -Inch Inside Diameter $\times \frac{55}{64}$ -Inch Outside Diameter $\times \frac{1}{4}$ -Inch Thick
78-70501SC	2-Inch Diameter Capacitor Mounting Bracket
79-15021001	2-Circuit Single-Row Terminal Block
79.3206	5-Position 3AG Fuse Block with $\frac{1}{4}$ -Inch Quick-Disconnect Terminals
79.4411001	Panel-Mounting Non-Indicating 3AG Cartridge-Type Fuse Post
034482.02	Power Supply Chassis
034544-01	Fuse Block Cover
03763901	Label for Fuse Value <b>(F1)</b>
03764101	Label for Fuse Values <b>(F2-F6)</b>



**NOTE**  
 To ensure that the fluorescent tube starts, make sure the ground wire is firmly attached to both the ballast transformer and the steel lamp bracket.

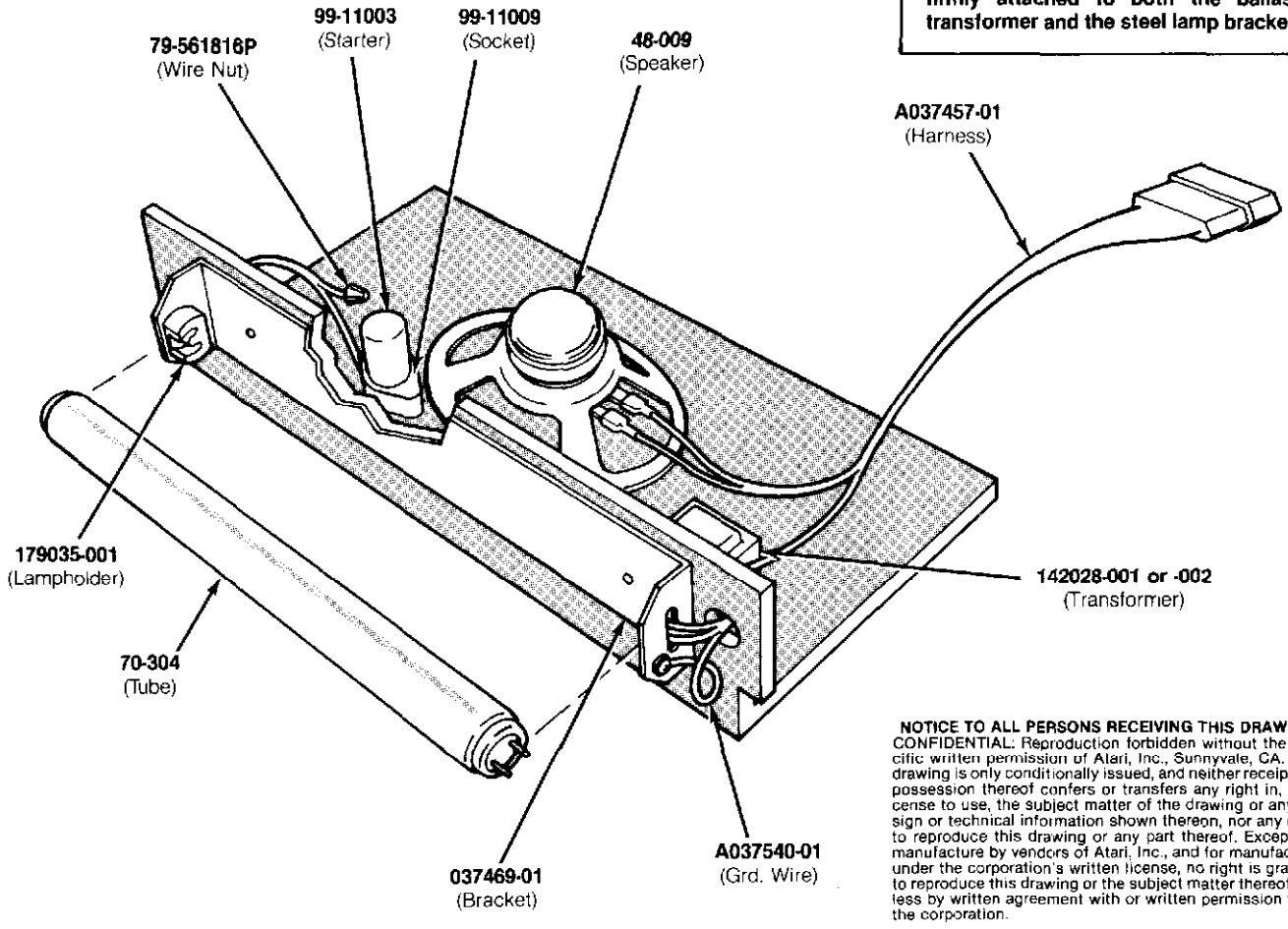

**NOTICE TO ALL PERSONS RECEIVING THIS DRAWING**  
 CONFIDENTIAL: Reproduction forbidden without the specific written permission of Atari, Inc., Sunnyvale, GA. This drawing is only conditionally issued, and neither receipt nor possession thereof confers or transfers any right in, or license to use, the subject matter of the drawing or any design or technical information shown thereon, nor any right to reproduce this drawing or any part thereof. Except for manufacture by vendors of Atari, Inc., and for manufacture under the corporation's written license, no right is granted to reproduce this drawing or the subject matter thereof, unless by written agreement with or written permission from the corporation.

**Figure 23 Fluorescent Light and Speaker Assembly  
 A037417-01 and -02 B**

**Parts List**

Part No.	Description
A037457-01	Light and Speaker Harness
A037540-01	Ground Wire with Ring Lug
48.009	8-Inch High-Fidelity Speaker
70.304	18-Inch 15-Watt Cool White Fluorescent Tube
79-561816P	Spring-Connector Wire Nut for 16- to 18-Gauge Wires
99.11003	Fluorescent Lamp Starter
99-11009	Starter Socket
03746901	Steel Lamp Bracket
142028-001	60-Hz 118-Volt Ballast Transformer (used on A03741701 assembly)
142028002	50-Hz 118-Volt Ballast Transformer (used on A037477-02 assembly)
179035001	2-Pin Fluorescent Lampholder

**NOTICE TO ALL PERSONS RECEIVING THIS DRAWING**  
**CONFIDENTIAL:** Reproduction forbidden without the specific written permission of Atari, Inc., Sunnyvale, CA. This drawing is only conditionally issued, and neither receipt nor possession thereof confers or transfers any right in, or license to use, the subject matter of the drawing or any design or technical information shown thereon, nor any right to reproduce this drawing or any part thereof. Except for manufacture by vendors of Atari, Inc., and for manufacture under the corporation's written license, no right to reproduce this drawing is granted or the subject matter thereof unless by written agreement with or written permission from the corporation.

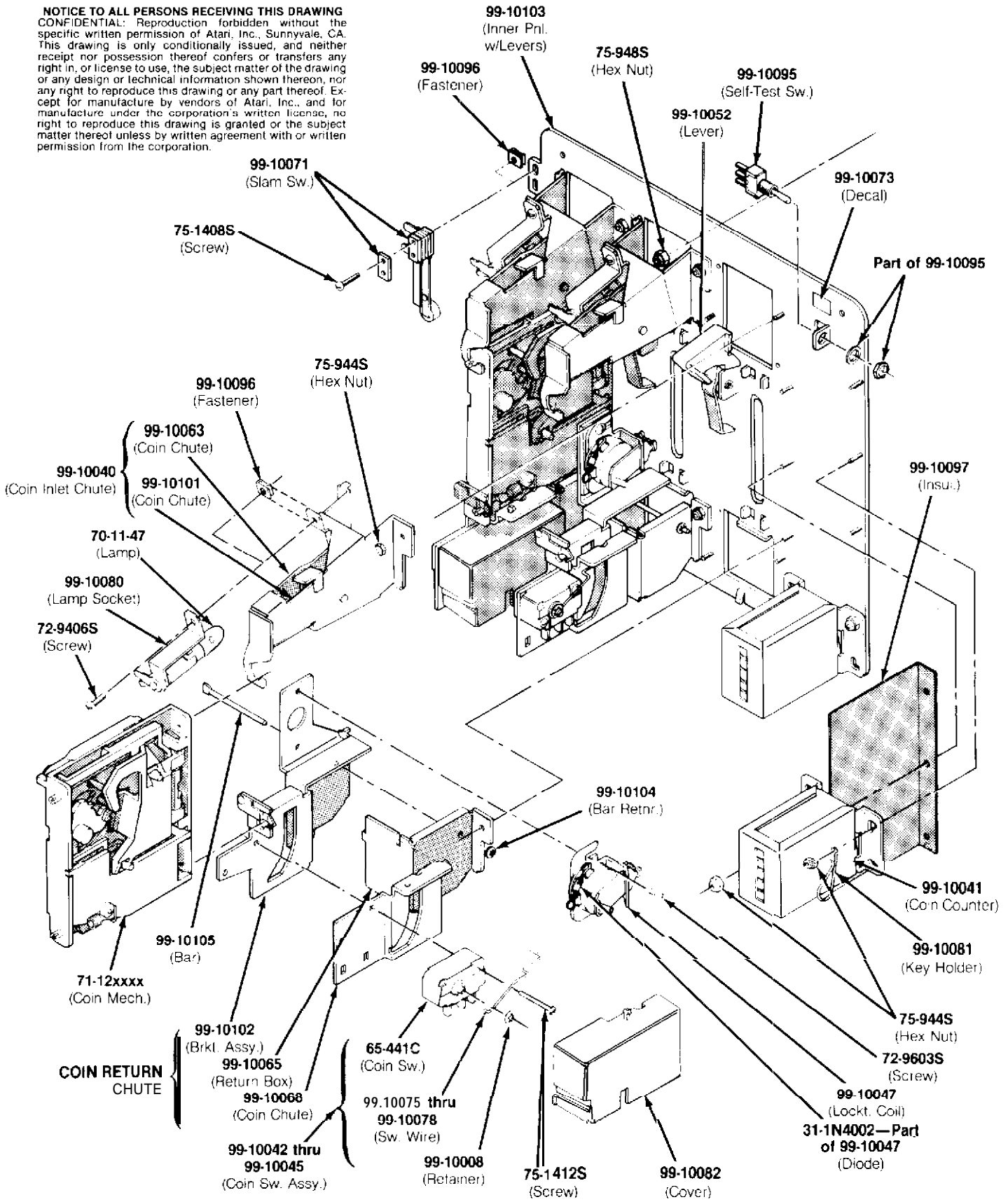

**Figure 24 American-Made Coin Door  
 71-10xxxx D**

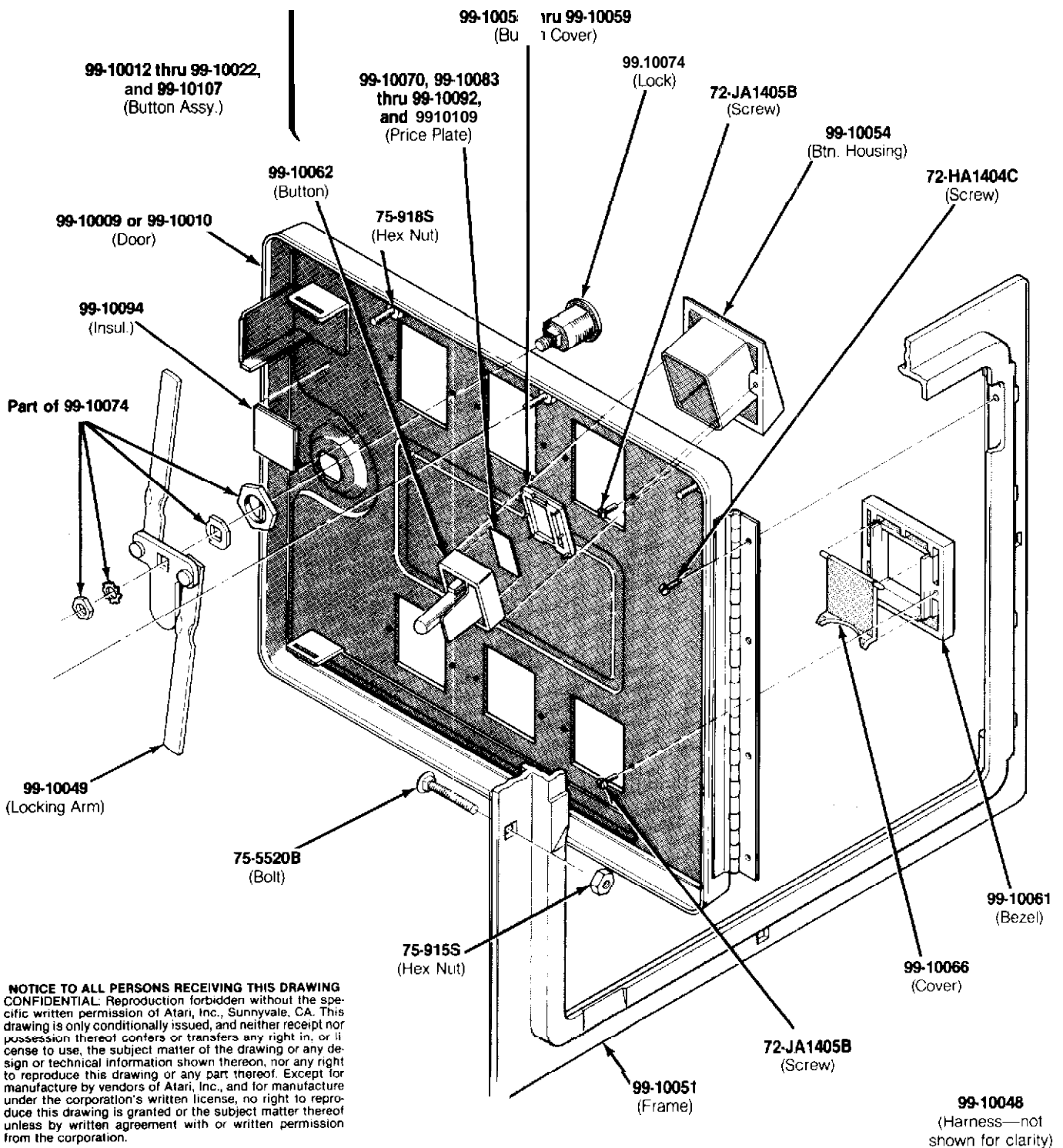

- 71-102201 — U.S. 25¢/25¢ Coin Door
- 71-103202 — U.S. 25¢/25¢/25¢ Coin Door
- 71-103203 — U.S. 25¢/25¢/\$1 Coin Door
- 71-102204 — German 2 DM/1 DM Coin Door
- 71-103205 — German 1/2/5 DM Coin Door

- 71-102206 — German 1 DM/5 DM Coin Door
- 71-102207 — Belgian 5 Fr/5 Fr Coin Door
- 71-102208 — Swiss 1 Fr/1 Fr Coin Door
- 71-102209 — Japanese 100Y/100Y Coin Door
- 71-102210 — British 10 P/10 P Coin Door

- 71-102211 — Australian 20¢/20¢ Coin Door
- 71-102212 — Italian 100 L/100 L Coin Door
- 71-102213 — U.S. 50¢/50¢ (2 × 25¢) Coin Door
- 71-103214 — U.S. 50¢/50¢/50¢ Coin Door
- 71-103215 — U.S. 50¢/50¢/\$1 Coin Door

**Figure 24 American-Made Coin Door  
71-10xxxx D**



## Figure 24 American-Made Coin Door, continued Parts List

Part No.	Description
31-1N4002	100V Silicon Rectifier IN4002 Diode
65.441 c	General-Usage Low-Force Miniature Switch
70-11-47	Miniature Bayonet-Base Incandescent Lamp, Type #47
71-1201ADU	U.S. 51.00 Coin Mechanism
71-1201 FCH	Swiss 1 Fr Coin Mechanism
71-1201MG	German 1 DM Coin Mechanism
71-1202MG	German 2 DM Coin Mechanism
71-1205FB	Belgian 5 Fr Coin Mechanism
71-1205MG	German 5 DM Coin Mechanism
71-1210PE	U.K. 10 P Coin Mechanism
71-1220CA	Australian 20¢ Coin Mechanism
71-1225CU	U.S. 25¢ Coin Mechanism
71-12100LI	Italian 100 Lire Coin Mechanism
71-12100YJ	Japanese Y100 Coin Mechanism
72-HA1404C	#4x 1/4-Inch Slotted Pan-Head Thread-Rolling Tri-Fluted "Taptite" Cadmium-Plated Screw
72-JA1405B	#4x 5/16-Inch Slotted Pan-Head Thread-Rolling Tri-Fluted "Plastite" Black Screw
72-9406S	#4-40 x 5/8-Inch Slotted Truss-Head Steel Machine Screw
72-9603S	#6-32 x 5/16-Inch Slotted Truss-Head Steel Machine Screw
75915s	#1/4-20 Standard-Pattern Cadmium-Plated Steel Hex Nut
75.91 as	#8-32 Standard-Pattern Cadmium-Plated Steel Hex Nut
75-944S	#4-40 Polymer Self-Locking Steel Hex Nut
75-948S	#8-32 Polymer Self-Locking Steel Hex Nut
751406s	#4-40 x M-Inch Slotted Pan-Head Steel Machine Screw
75-1412S	#4-40 x 3/4-Inch Slotted Pan-Head Steel Machine Screw
7555208	#1/4-20 x 1 1/4-Inch Round-Head Square-Neck Steel Bolt with Black Finish
99-10008	Switch Wire Retainer
99-10009	2-Mech Coin Door Only
99-10010	3-Mech Coin Door Only
99-10012	US. 250 Coin Return Button Assembly
99-10013	U.S. \$1.00 Coin Return Button Assembly
99-10014	German 1 DM Coin Return Button Assembly
99.10015	German 2 DM Coin Return Button Assembly
99.10016	German 5 DM Coin Return Button Assembly
99-10017	Belgian 5 Fr Coin Return Button Assembly
99-10018	Swiss 1 Fr Coin Return Button Assembly
99-10019	Japanese Y100 Coin Return Button Assembly
99-10020	U.K. 10 P Coin Return Button Assembly
99-10021	Australian 200 Coin Return Button Assembly
99.10022	Italian 100 Lire Coin Return Button Assembly
99.10040	Coin Inlet Chute Assembly
99-10041	Coin Counter Assembly
99.10042	Coin Switch Assembly for U.S. 250 and Belgian 5 Fr Coins (silver wire)
99.10043	Coin Switch Assembly for German 1 DM, Swiss 1 Fr, and Japanese Y100 Coins (black wire)
9910044	Coin Switch Assembly for U.S. \$1.00, German 2 DM, and Italian 100 Lire Coins (gold wire)
99-10045	Coin Switch Assembly for German 5 DM, U.K. 10 P, and Australian 20¢ Coins (green wire)
99-I 0047	Lockout Coin Assembly
99-10048	Coin Door Harness Assembly

## Figure 24 American-Made Coin Door, continued Parts List

<i>Part No.</i>	<i>Description</i>
9410049	Locking Arm Assembly
<del>99-10051</del>	Coin Door Frame
<del>99-10052</del>	Coin Return Lever
<del>99-10054</del>	Coin Button Housing
9910055	Coin Return Button Cover for Japanese 100Y Coin
99.10056	Coin Return Button Cover for German 1 DM and Swiss 1 Fr Coins
<del>99-10057</del>	Coin Return Button Cover for U.S. 250 and Belgian 5 Fr Coins
<del>99-10058</del>	Coin Return Button Cover for U.S. \$1.00, German 2 DM, and Italian 100 Lire Coins
99.10059	Coin Return Button Cover for German 5 DM, U.K. 10 P, and Australian 20¢ Coins
99.10061	Coin Return Bezel
9910062	Coin Return Button
<del>99-10063</del>	Right Half of Coin Inlet Chute
<del>99-10065</del>	Coin Return Box
99.10066	Coin Return Cover
<del>99-10068</del>	Coin Chute
99-10070	U.S. 25¢ Price Plate
99-10071	Slam Switch Assembly
99.10073	Test Switch Decal
<del>99-10074</del>	Lock Assembly
99.10075	Black Switch Wire for German 1 DM, Swiss 1 Fr and Japanese 100Y Coins
9910076	Silver Switch Wire for U.S. 25¢ and Belgian 5 Fr Coins
99.10077	Gold Switch Wire for U.S. \$1.00, German 2 DM and Italian 100 Lire Coins
<del>99-10078</del>	Green Switch Wire for German 5 DM, U.K. 10 P and Australian 20¢ Coins
9410080	Miniature Bayonet-Base Lamp Socket
99-10081	Wire Key Holder
9410082	Switch Cover
<del>99-10083</del>	U.S. \$1.00 Price Plate
9910084	German 1 DM Price Plate
<del>99-10085</del>	German 2 DM Price Plate
9910086	German 5 DM Price Plate
99-10087	Belgian 5 Fr Price Plate
9410088	Swiss 1 Fr Price Plate
99-10089	Japanese ¥100 Price Plate
9910090	U.K. 10 P Price Plate
9410091	Australian 20¢ Price Plate
99.10092	Italian 100 Lire Price Plate
<del>99-10094</del>	Fish Paper Insulation
<del>99-10095</del>	Toggle Switch
99-10096	"U"-Type Fastener
<del>99-10097</del>	Fish Paper Insulation
<del>99-10101</del>	Left Half of Coin Inlet Chute
99-10102	Switch and Lockout Coil Bracket Sub-Assembly
99-10103	Inner Panel with Levers Sub-Assembly
99-10104	Anti-Penny-Flip Bar Retainer
9910105	Anti-Penny-Flip Bar
99-10107	U.S. 50¢ Coin Return Button Assembly <i>(for two quarters)</i>
99-10108	U.S. 50¢ Price Plate <i>(for two quarters)</i>

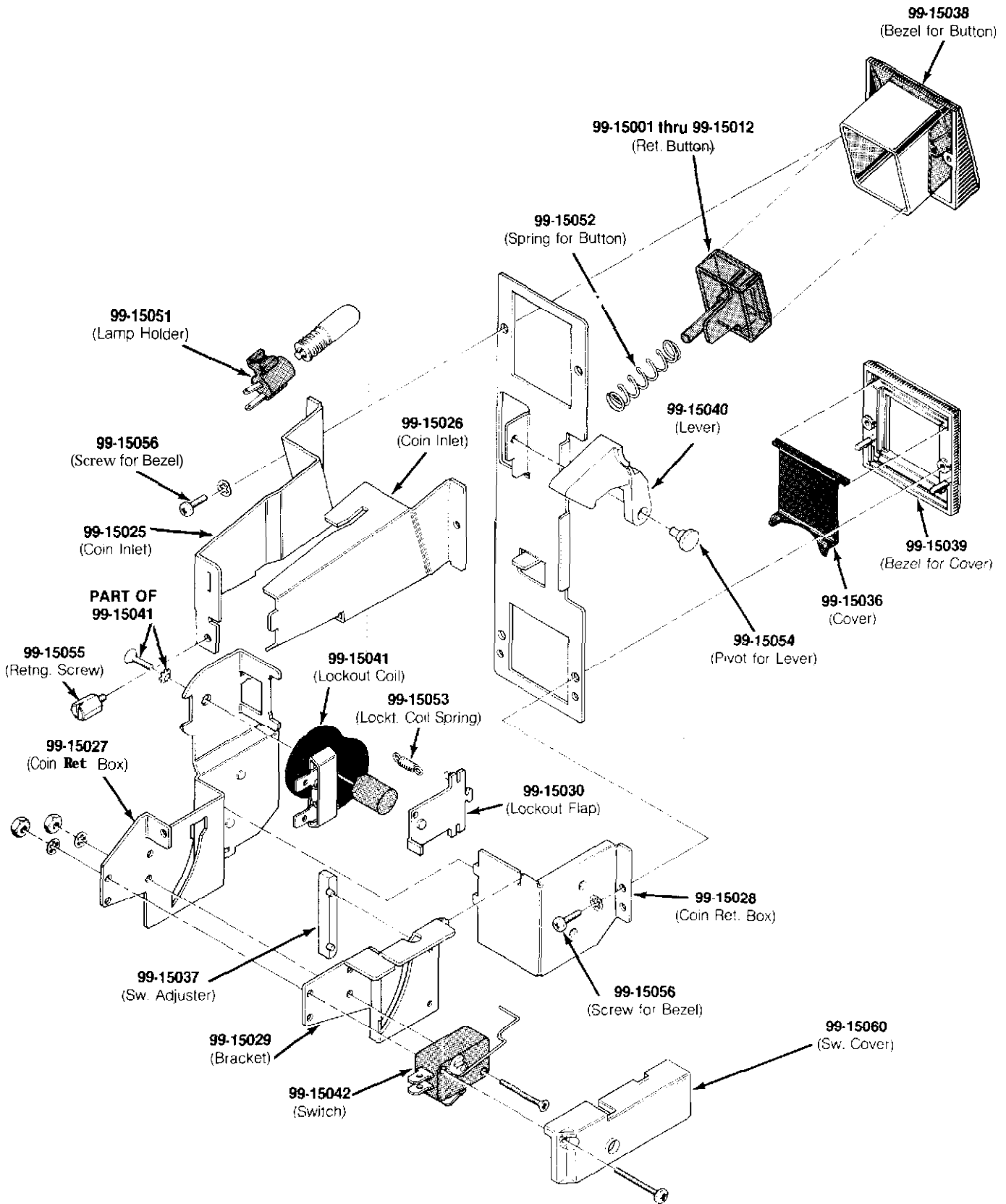
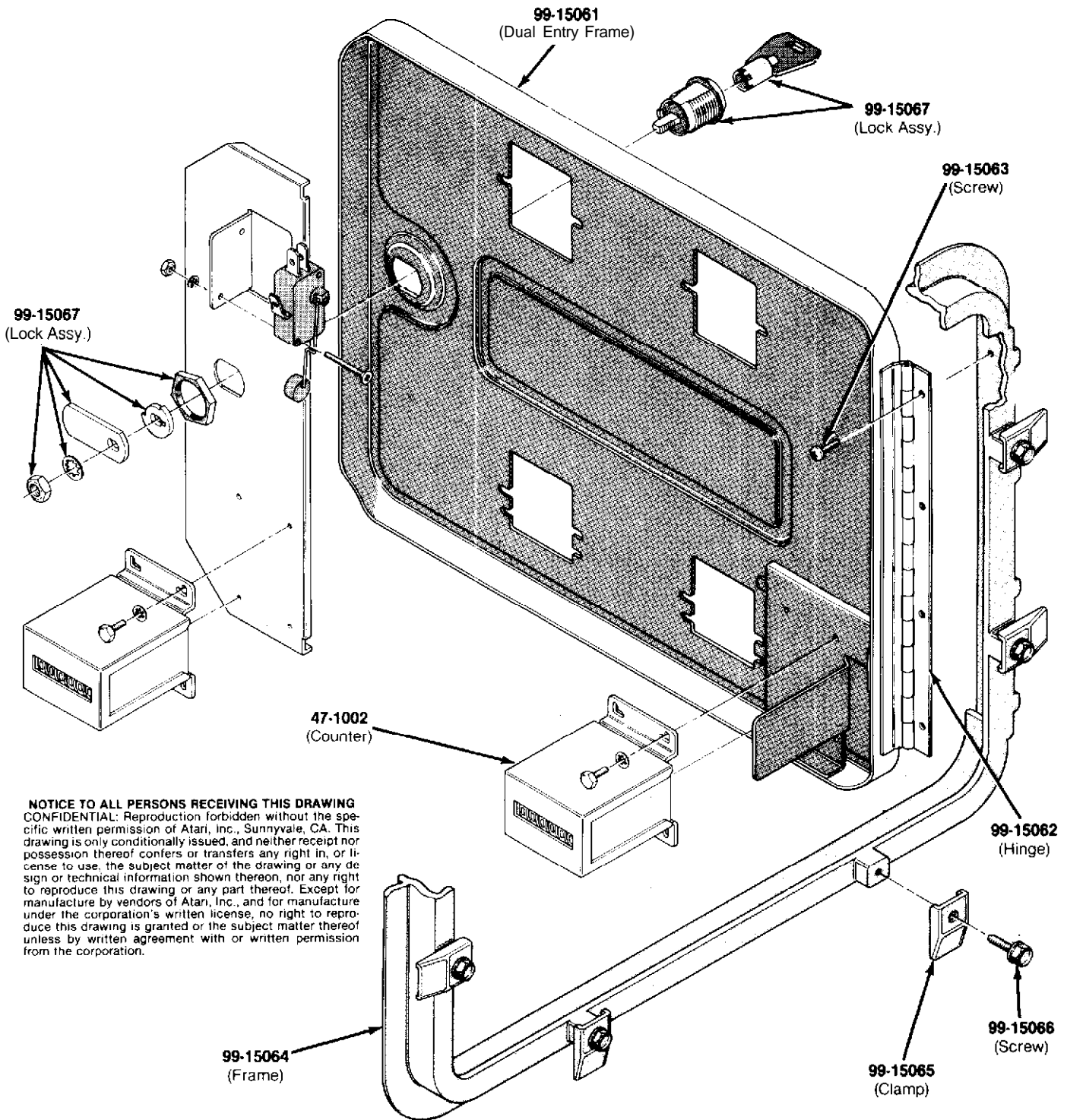

Figure 25 British-Made Coin Door  
171001-xxx A



**NOTICE TO ALL PERSONS RECEIVING THIS DRAWING**  
**CONFIDENTIAL:** Reproduction forbidden without the specific written permission of Atari, Inc., Sunnyvale, CA. This drawing is only conditionally issued, and neither receipt nor possession thereof confers or transfers any right in, or license to use, the subject matter of the drawing or any design or technical information shown thereon, nor any right to reproduce this drawing or any part thereof. Except for manufacture by vendors of Atari, Inc., and for manufacture under the corporation's written license, no right to reproduce this drawing is granted or the subject matter thereof unless by written agreement with or written permission from the corporation.

171001-001 — British 10 P/10 P Coin Door  
 171001-002 — British 10 P/50 P Coin Door  
 171001-003 — British 20 P/50 P Coin Door  
 171001-004 — German 1 DM/1 DM Coin Door  
 171001-005 — German 2 DM/1 DM Coin Door

171000-006 — German 2 DM/5 DM Coin Door  
 171001-007 — Belgian 5 Fr/5 Fr Coin Door  
 171001-008 — French 1 Fr/1 Fr Coin Door  
 171001-009 — French 2 Fr/1 Fr Coin Door  
 171001-010 — Swedish 1 Kr/1 Kr Coin Door

171000-011 — Hong Kong \$1/\$1 Coin Door  
 171001-012 — Canadian 25¢/25¢ Coin Door  
 171001-013 — U.S. 25¢/25¢ Coin Door  
 171001-014 — Spanish 25 Pts/25 Pts Coin Door  
 171001-015 — Swiss 1 Fr/1 Fr Coin Door

**Figure 25 British-Made Coin Door**  
**171001-xxx A**