

QT3619FX

QT3619K

QT3549W

QT3549FX

QT3549K

User manual

Freezer

Thank you for choosing one of our high-quality products.

To ensure optimal and regular performance of your appliance please read this instruction manual carefully. It will enable you to navigate all processes perfectly and most efficiently. To refer to this manual any time you need to, we recommend you to keep it in a safe place. And please pass it to any future owner of the appliance.

We wish you much joy with your new appliance.

## Contents

|                                       |   |  |    |
|---------------------------------------|---|--|----|
| <b>Safety information</b>             | 3 | Freezing fresh food                          | 9  |
| Children and vulnerable people safety |   | Storage of frozen food                       | 9  |
| General safety                        | 3 | Thawing                                      | 10 |
| Daily Use                             | 4 | Shelf above ice maker                        | 10 |
| Care and cleaning                     | 4 | Removing the ice container                   | 10 |
| Installation                          | 4 | Removal of freezing baskets from the freezer | 11 |
| Service                               | 5 | <b>Helpful hints and tips</b>                | 11 |
| <b>Control panel</b>                  | 5 | Hints for freezing                           | 11 |
| Switching on                          | 6 | Hints for storage of frozen food             | 11 |
| Switching off                         | 6 | <b>Care and cleaning</b>                     | 12 |
| Temperature indicator                 | 6 | Periodic cleaning                            | 12 |
| Temperature regulation                | 6 | Cleaning the ice maker                       | 12 |
| Ice maker function                    | 6 | Cleaning the ventilation grille              | 12 |
| Super Action Freeze function          | 6 | Defrosting of the freezer                    | 13 |
| High temperature alarm                | 7 | Periods of non-operation                     | 13 |
| Door open alarm                       | 7 | <b>What to do if...</b>                      | 13 |
| <b>Ice dispenser</b>                  | 7 | Replacing the lamp                           | 15 |
| Child lock function                   | 8 | Closing the door                             | 16 |
| Temporary unlocking                   | 8 | <b>Technical data</b>                        | 16 |
| Permanent unlocking                   | 8 | <b>Installation</b>                          | 16 |
| To activate the child lock function   | 8 | Positioning                                  | 16 |
| Lighting                              | 8 | Location                                     | 17 |
| For continuous lighting               | 8 | Electrical connection                        | 17 |
| Switch off the lighting               | 8 | Removing the transport support               | 17 |
| Delivery of ice                       | 8 | Rear spacers                                 | 18 |
| Switch off the ice maker              | 8 | Connecting the water hose.                   | 18 |
| Night mode                            | 8 | Levelling                                    | 19 |
| To activate the night mode            | 8 | Starting the ice maker for the first time.   | 19 |
| Switch off the night mode             | 9 | Door reversibility                           | 19 |
| <b>First use</b>                      | 9 | <b>Environmental concerns</b>                | 19 |
| Cleaning the interior                 | 9 |  |    |
| <b>Daily use</b>                      | 9 |  |    |



## Safety information

In the interest of your safety and to ensure the correct use, before installing and first using the appliance, read this user manual carefully, including its hints and warnings. To avoid unnecessary mistakes and accidents, it is important to ensure that all people using the appliance are thoroughly familiar with its operation and safety features. Save these instructions and make sure that they remain with the appliance if it is moved or sold, so that everyone using it through its life will be properly informed on appliance use and safety. For the safety of life and property keep the precautions of these user's instructions as the manufacturer is not responsible for damages caused by omission.

### Children and vulnerable people safety

- This appliance is not intended for use by persons (including children) with reduced physical, sensory or mental capabilities, or lack of experience and knowledge, unless they have been given supervision or instruction concerning use of the appliance by a person responsible for their safety.

Children should be supervised to ensure that they do not play with the appliance.

- Keep all packaging well away from children. There is risk of suffocation.
- If you are discarding the appliance pull the plug out of the socket, cut the connection cable (as close to the appliance as you can) and remove the door to prevent playing children to suffer electric shock or to close themselves into it.
- If this appliance featuring magnetic door seals is to replace an older appliance having a spring lock (latch) on the door or lid, be sure to make that spring lock unusable before you discard the old appliance. This will prevent it from becoming a death trap for a child.

### General safety



#### **CAUTION!**

Keep ventilation openings clear of obstruction.

- The appliance is intended for keeping foodstuff and/or beverages in a normal household as explained in this instruction booklet.
- Do not use a mechanical device or any artificial means to speed up the thawing process.
- Do not use other electrical appliances (such as ice cream makers) inside of refrigerating appliances, unless they are approved for this purpose by the manufacturer.
- Do not damage the refrigerant circuit.
- The refrigerant isobutane (R600a) is contained within the refrigerant circuit of the appliance, a natural gas with a high level of environmental compatibility, which is nevertheless flammable.

During transportation and installation of the appliance, be certain that none of the components of the refrigerant circuit become damaged.

If the refrigerant circuit should become damaged:

- avoid open flames and sources of ignition
- thoroughly ventilate the room in which the appliance is situated
- It is dangerous to alter the specifications or modify this product in any way. Any damage to the cord may cause a short-circuit, fire and/or electric shock.

**WARNING!**

Any electrical component (power cord, plug, compressor) must be replaced by a certified service agent or qualified service personnel.

1. Power cord must not be lengthened.
  2. Make sure that the power plug is not squashed or damaged by the back of the appliance. A squashed or damaged power plug may overheat and cause a fire.
  3. Make sure that you can come to the mains plug of the appliance.
  4. Do not pull the mains cable.
  5. If the power plug socket is loose, do not insert the power plug. There is a risk of electric shock or fire.
  6. You must not operate the appliance without the lamp cover<sup>1)</sup> of interior lighting.
- This appliance is heavy. Care should be taken when moving it.
  - Do not remove nor touch items from the freezer compartment if your hands are damp/wet, as this could cause skin abrasions or frost/freezer burns.
  - Avoid prolonged exposure of the appliance to direct sunlight.
  - Bulb lamps<sup>2)</sup> used in this appliance are special purpose lamps selected for household appliances use only. They are not suitable for household room illumination.

## Daily Use

- Do not put hot pot on the plastic parts in the appliance.
- Do not store flammable gas and liquid in the appliance, because they may explode.
- Do not place food products directly against the air outlet on the rear wall.<sup>3)</sup>
- Frozen food must not be re-frozen once it has been thawed out.
- Store pre-packed frozen food in accordance with the frozen food manufacturer's instructions.
- Appliance's manufacturers storage recommendations should be strictly adhered to. Refer to relevant instructions.
- Do not place carbonated or fizzy drinks in the freezer compartment as it creates pressure on the container, which may cause it to explode, resulting in damage to the appliance.
- Ice lollies can cause frost burns if consumed straight from the appliance.

## Care and cleaning

- Before maintenance, switch off the appliance and disconnect the mains plug from the mains socket.
- Do not clean the appliance with metal objects.
- Do not use sharp objects to remove frost from the appliance. Use a plastic scraper.
- Never use a hair drier or other heating appliances to speed up defrosting. Excessive heat may damage the plastic interior, and humidity could enter the electric system making it live.

## Installation



For electrical connection carefully follow the instructions given in specific paragraphs.

1) If the lamp cover is foreseen

2) If the lamp is foreseen

3) If the appliance is Frost Free

- Unpack the appliance and check if there are damages on it. Do not connect the appliance if it is damaged. Report possible damages immediately to the place you bought it. In that case retain packing.
- It is advisable to wait at least four hours before connecting the appliance to allow the oil to flow back in the compressor.
- Adequate air circulation should be around the appliance, lacking this leads to overheating. To achieve sufficient ventilation follow the instructions relevant to installation.
- Wherever possible the back of the product should be against a wall to avoid touching or catching warm parts (compressor, condenser) to prevent possible burn.
- The appliance must not be located close to radiators or cookers.
- Make sure that the mains plug is accessible after the installation of the appliance.
- Connect to potable water supply only.<sup>4)</sup>

## Service

- Any electrical work required to do the servicing of the appliance should be carried out by a qualified electrician or competent person.
- This product must be serviced by an authorized Service Centre, and only genuine spare parts must be used.

## Environment Protection



This appliance does not contain gasses which could damage the ozone layer, in either its refrigerant circuit or insulation materials. The appliance shall not be discarded together with the urban refuse and rubbish. The insulation foam contains flammable gases: the appliance shall be disposed according to the applicable regulations to obtain from your local authorities. Avoid damaging the cooling unit, especially at the rear near the heat exchanger. The materials used on this appliance marked by the symbol are recyclable.

## Control panel

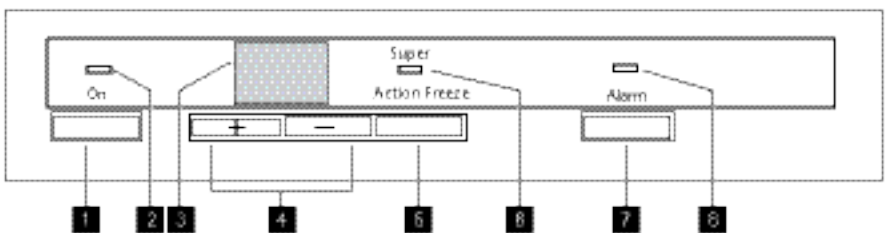

1. On button
2. Pilot light
3. Temperature indicator
4. Temperature regulator, + and - buttons.
5. Super Action Freeze button
6. Super Action Freeze light
7. Alarm reset button

4) If a water connection is foreseen

## 8. Alarm light

### Switching on

Insert the plug into the wall socket.

If the pilot light and the display is not illuminated, press ON/OFF button.

Select a temperature according to "Temperature regulation".



If the door remains open for some minutes, the light will turn off automatically. The light is reset by closing and opening the door.

### Switching off

Press the ON/OFF button until a countdown is completed from -3 -2 -1.

The temperature indicator and the Pilot light switches off.

### Temperature indicator

- During normal operation, the temperature indicator shows the current temperature inside the appliance (ACTUAL temperature).
- During temperature adjusting operation, the temperature indicator flashes the appliance temperature currently set (DESIRED temperature).

### Temperature regulation

To operate the appliance, proceed as follows:

1. Set the required temperature by pressing the corresponding temperature regulator. The temperature indicator flashes the DESIRED temperature.
2. Each time the temperature regulator is pressed the DESIRED temperature is adjusted by 1 °C. The DESIRED temperature is reached within 24 hours.

Once the DESIRED temperature has been set, after a short period (approx. 5 sec.) the temperature indicator will show again the ACTUAL temperature inside the compartment. The temperature indicator will change from flashing to continuous illumination.

For a correct storage of the food the following temperature should be set:

- -18 °C in the freezer.

### Ice maker function

The ice maker is switched on at delivery and starts up automatically when the appliance is connected to water and power supplies.

Press the Alarm reset button to switch on and off the ice maker.

### Super Action Freeze function

The Super Action Freeze function accelerates the freezing of fresh food and, at the same time, protects foodstuffs already stored from undesirable warming.

To activate the function, do these steps:

1. Press the Super Action Freeze button.
2. The Super Action Freeze indicator will light up and the Temperature indicator shows SF (approx. 5 sec).

To deactivate the function, do these steps:

1. Press the Super Action Freeze button.
2. The Super Action Freeze indicator goes out.

The Super Action Freeze function stops automatically after about 52 hours.



## High temperature alarm

Temperature increase in the freezer compartment (for example due to an earlier power failure or door is open) is indicated by:

- Alarm light flashing
- flashing temperature
- sounding of buzzer

When normal conditions are restored:

- the acoustic alarm stops
- the temperature value continues to flash
- the Alarm light continues to flash

When you press the Alarm reset button to deactivate the alarm, the highest temperature reached in the compartment appears on indicator   for some seconds.

Then it returns on the normal operation showing the temperature in the freezer.

During the alarm phase, the buzzer can be switched off by pressing the Alarm reset button.

## Door open alarm

An acoustic alarm will sound if the door is left open for a few minutes. The door open alarm conditions are indicated by:

- Alarm light flashing
- acoustic buzzer

Press the Alarm reset button to cancel the acoustic alarm.

When normal conditions are restored (door closed) the Alarm will stop automatically.

## Ice dispenser

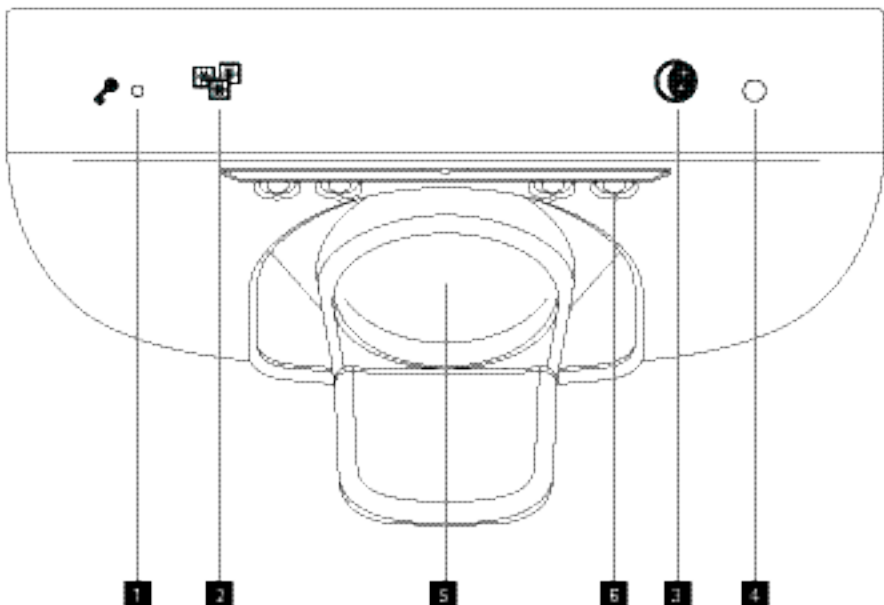

- 1 Child lock indicator
- 2 Locking function button
- 3 Night/lighting button
- 4 Photo electric sensor
- 5 Paddle
- 6 Illumination

## Child lock function

The child lock function is activated at delivery.

## Temporary unlocking

Press button 2 or 3 for about three seconds until the child lock indicator light (1) goes out. The child lock function is reactivated automatically after about three seconds.

## Permanent unlocking

Press buttons 2 and 3 at the same time for about three seconds.

The button 2 or 3 lights up to indicate unlocking and the child lock indicator (1) goes out.

## To activate the child lock function

Press buttons 2 and 3 at the same time for about three seconds.

The child lock indicator is lit when activated.

## Lighting

The ice dispenser lighting (6) illuminates automatically when operated.

## For continuous lighting

1. Make sure that the ice dispenser is unlocked.
2. Press button (3) until the lighting goes on (about three seconds).  
Brightness is now about 50% until the dispenser is used.

## Switch off the lighting

1. Make sure that the ice dispenser is unlocked.
2. Press the button (3) until the lighting goes out (about three seconds).

## Delivery of ice

The delivery of ice start when the paddle (5) is fully depressed and continues until the paddle is released.

Stop delivery by removing the container from the paddle.

## Switch off the ice maker

Refer to "Ice maker function" under Control panel.

## Night mode

This function switches off the noise producing parts of the ice maker during the night

## To activate the night mode

1. Make sure that the ice dispenser is unlocked.



2. Press and release the button (3) and the lighting goes on.

## Switch off the night mode

1. Make sure that the ice dispenser is unlocked.
2. Press and release the button (3) and the lighting goes out.



If increased ice production capacity is desired, it is advantageous to press the Action freeze button in the top panel.

The Action freeze function stops automatically.

## First use

### Cleaning the interior

Before using the appliance for the first time, wash the interior and all internal accessories with lukewarm water and some neutral soap so as to remove the typical smell of a brand-new product, then dry thoroughly.



Do not use detergents or abrasive powders, as these will damage the finish.

## Daily use

### Freezing fresh food

The freezer compartment is suitable for freezing fresh food and storing frozen and deep-frozen food for a long time.

To freeze small amount of fresh foods it is not necessary to change the present setting.

To freeze fresh food activate the Super Action Freeze function at least 24 hours before placing the food to be frozen in the freezer compartment.

Place the fresh food to be frozen in all compartments except the bottom drawer.

The maximum amount of food that can be frozen in 24 hours is specified on the **rating plate**, a label located on the inside of the appliance.

The freezing process lasts 24 hours: during this period do not add other food to be frozen.

### Storage of frozen food

When first starting-up or after a period out of use, before putting the products in the compartment let the appliance run at least 2 hours.

The freezer baskets ensure that it is quick and easy to find the food package you want. If large quantities of food are to be stored, remove all drawers except for the bottom basket which needs to be in place to provide good air circulation. On all shelves except for the top shelf it is possible to place food that protrude until load limit stated on the side of the middle section





In the event of accidental defrosting, for example due to a power failure, if the power has been off for longer than the value shown in the technical characteristics chart under "rising time", the defrosted food must be consumed quickly or cooked immediately and then re-frozen (after cooling).

## Thawing

Deep-frozen or frozen food, prior to being used, can be thawed in the refrigerator compartment or at room temperature, depending on the time available for this operation. Small pieces may even be cooked still frozen, directly from the freezer: in this case, cooking will take longer.

## Shelf above ice maker



The shelf above the ice maker cannot be removed.

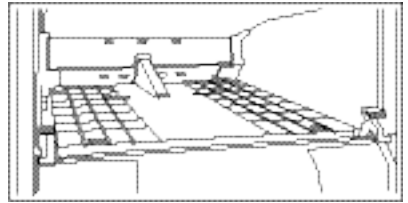

## Removing the ice container

The ice container can be removed.

1. Tilt up and pull the ice container outwards to removal.

When the ice container is pulled out, this stops all the functions of the ice machine.

2. When refitting (if necessary) the ice container feed screw should be positioned against the rear flange.

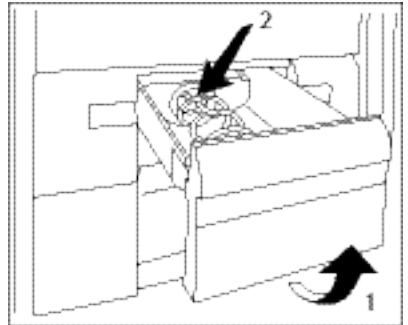

## Removal of freezing baskets from the freezer

The freezing baskets have a limit stop to prevent their accidental removal or falling out. At the time of its removal from the freezer, pull the basket towards yourself and, upon reaching the end point, remove the basket by tilting its front upwards.

At the time of putting it back, slightly lift the front of the basket to insert it into the freezer. Once you are over the end points, push the baskets back in their position.

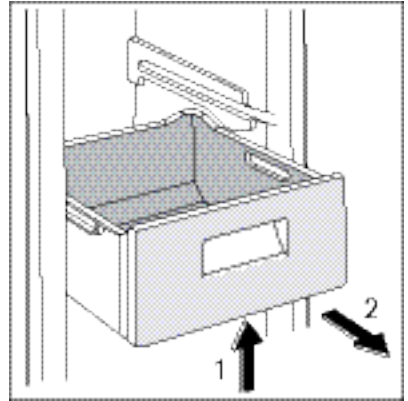

## Helpful hints and tips

### Hints for freezing

To help you make the most of the freezing process, here are some important hints:

- the maximum quantity of food which can be frozen in 24 hrs. is shown on the rating plate;
- the freezing process takes 24 hours. No further food to be frozen should be added during this period;
- only freeze top quality, fresh and thoroughly cleaned, foodstuffs;
- prepare food in small portions to enable it to be rapidly and completely frozen and to make it possible subsequently to thaw only the quantity required;
- wrap up the food in aluminium foil or polythene and make sure that the packages are airtight;
- do not allow fresh, unfrozen food to touch food which is already frozen, thus avoiding a rise in temperature of the latter;
- lean foods store better and longer than fatty ones; salt reduces the storage life of food;
- water ices, if consumed immediately after removal from the freezer compartment, can possibly cause the skin to be freeze burnt;
- it is advisable to show the freezing in date on each individual pack to enable you to keep tab of the storage time.

### Hints for storage of frozen food

To obtain the best performance from this appliance, you should:

- make sure that the commercially frozen foodstuffs were adequately stored by the retailer;
- be sure that frozen foodstuffs are transferred from the foodstore to the freezer in the shortest possible time;
- not open the door frequently or leave it open longer than absolutely necessary.
- Once defrosted, food deteriorates rapidly and cannot be refrozen.
- Do not exceed the storage period indicated by the food manufacturer.

## Care and cleaning



### CAUTION!

Unplug the appliance before carrying out any maintenance operation.



This appliance contains hydrocarbons in its cooling unit; maintenance and recharging must therefore only be carried out by authorized technicians.

## Periodic cleaning

The equipment has to be cleaned regularly:

- clean the inside and accessories with lukewarm water and some neutral soap.
- regularly check the door seals and wipe clean to ensure they are clean and free from debris.
- rinse and dry thoroughly.



Do not pull, move or damage any pipes and/or cables inside the cabinet.

Never use detergents, abrasive powders, highly perfumed cleaning products or wax polishes to clean the interior as this will damage the surface and leave a strong odour.

Clean the condenser (black grill) and the compressor at the back of the appliance with a brush or a vacuum cleaner. This operation will improve the performance of the appliance and save energy consumption.



Take care of not to damage the cooling system.



When moving the cabinet, lift it by the front edge to avoid scratching the floor.

Many proprietary kitchen surface cleaners contain chemicals that can attack/damage the plastics used in this appliance. For this reason use a soft cloth rinsed in warm water and neutral soap emulsion for cleaning external surfaces.



Do not use detergents or abrasive paste as these will damage the paint, or stainless steel anti finger print coating.

After cleaning, reconnect the equipment to the mains supply.

## Cleaning the ice maker

When necessary, clean the surfaces of the dispenser and the ice container that are accessible from the outside, using only a soft cloth and warm water.

Ensure that the ice container is thoroughly dry before being refitted.



Do not use detergents or abrasive paste.

## Cleaning the ventilation grille

The ventilation grille can be removed for washing.

Make sure the door is open and then:

1. Loosen the upper edge of the grille by pulling outward/downward.
2. Pull the grille straight out to completely remove it.
3. Vacuum clean under the cabinet.

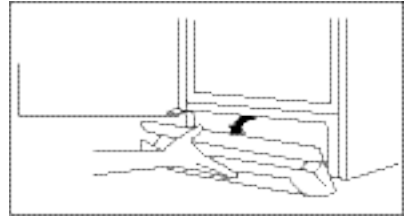

## Defrosting of the freezer

The freezer compartment of this model, on the other hand, is a "no frost" type. This means that there is no buildup of frost when it is in operation, neither on the internal walls nor on the foods.

The absence of frost is due to the continuous circulation of cold air inside the compartment, driven by an automatically controlled fan.

## Periods of non-operation

When the appliance is not in use for long periods, take the following precautions:

1. Switch of the ice machine
2. Turn off the water connection
3. Empty the ice container
4. Disconnect the appliance from electricity supply
5. Remove all food
6. Clean the appliance and all accessories
7. Leave the door/doors open to prevent unpleasant smells.

When the ice maker starts again, do not use ice produced during the first day to ensure fresh taste.



If the cabinet will be kept on, ask somebody to check it once in a while to prevent the food inside from spoiling in case of a power failure.

## What to do if...

During operation of the appliance some smaller but annoying trouble can often occur, which does not require calling a technician out. In the following chart information is given about them to avoid unnecessary charges on service.



The operation of the appliance goes with certain sounds (compressor and circulating sound). This not means a trouble, but a normal operation.



The appliance operates discontinuously, so the stopping of compressor does not mean being no current. That is why you must not touch the electrical parts of the appliance before breaking the circuit.

| Problem                        | Possible cause                           | Solution   |
|--------------------------------|--|--|
| <b>The appliance is noisy.</b> | The appliance is not supported properly. | Check if the appliance stands stable (all feet and wheels should be on the floor). Refer to "Levelling". |

| Problem   | Possible cause  | Solution   |
|---|---|--|
|   | The cushion spacers located between the back of the cabinet and the pipes come loose. | Put them back in place again.  |
| <b>A rattling noise.</b>  | The ice being stirred to prevent it from freezing together.                           | No measure necessary, this sound is normal.<br>As an alternative, refer to "To activate the night setting"                                       |
| <b>The buzzer sounds. The Alarm light flashing.</b>               | The temperature in the freezer is too high.   | Refer to "High Temperature Alarm".   |
|   | The door is not closed correctly.   | Refer to "Door open alarm".  |
| <b>Upper or lower square is shown in the temperature display.</b> | An error has occurred in measuring the temperature.                                   | Call your service representative (the cooling system will continue to keep food products cold, but temperature adjustment will not be possible). |
| <b>The compressor runs continuously.</b>                          | The Temperature regulator may be set incorrectly.                                     | Set a warmer temperature.  |
|   | The door is not closed correctly.   | Refer to "Closing the door".   |
|   | The door has been opened too frequently.  | Do not keep the door open longer than necessary.   |
|   | The food temperature is too high.   | Let the food temperature decrease to room temperature before storage.  |
|   | The room temperature is too high.   | Decrease the room temperature.   |
| <b>There is too much frost and ice.</b>                           | The door is not closed correctly.   | Refer to "Closing the door".   |
|   | The door gasket is deformed or dirty.   | Refer to "Closing the door".   |
| <b>The temperature in the appliance is too cold.</b>              | The Temperature regulator may be set incorrectly.                                     | Set a warmer temperature.  |
| <b>The temperature in the appliance is too warm.</b>              | The Temperature regulator may be set incorrectly.                                     | Set a colder temperature.  |
|   | The door is not closed correctly.   | Refer to "Closing the door".   |
|   | The food temperature is too high.   | Let the food temperature decrease to room temperature before storage.  |
| <b>The temperature in the freezer is too warm.</b>                | Food is too near to each other.   | Store food so that there is cold air circulation.  |
|   | Large quantities of food to be frozen were put in at the same time.                   | Insert smaller quantities of food to be frozen at the same time.   |

| Problem   | Possible cause   | Solution   |
|---|--|--|
| <b>The appliance does not operate.</b>                              | The appliance is switched off.                                       | Switch on the appliance.   |
|   | The mains plug is not connected to the mains socket correctly.       | Connect the mains plug to the mains socket correctly.  |
|   | The appliance has no power. There is no voltage in the mains socket. | Connect another electrical appliance to the mains socket. Check fuse. Contact a qualified electrician.                   |
| <b>No ice.</b>  | The ice maker is not switched on.                                    | Refer to "Switching on and off the ice maker".   |
|   | No water supply.   | Carry out the necessary measures on the water supply.  |
| <b>The ice dispenser lamp and the child lock indicator flashes.</b> | Leakage in the connection box.                                       | Contact service.   |
|   | The ice channel in the door is blocked.                              | Remove the obstacle.   |
|   | No water supply.   | Carry out the necessary measures on the water supply.<br>Reset the system by pressing the button 2 on the ice dispenser. |
| <b>The lamp does not work.</b>                                      | The lamp is defective.   | Refer to "Replacing the lamp".   |
|   | The door has been open too long.                                     | Close the door.  |
| <b>Door interferes with ventilation grill.</b>                      | The appliance is not levelled.                                       | Refer to "Levelling".  |
| <b>Misaligned door.</b>   | The appliance is not levelled.                                       | Refer to "Levelling".  |

As much as the advice does not lead to result, call the nearest brand-mark service.

## Replacing the lamp

1. Disconnect the appliance from the power socket.
2. Press the spring and at the same time pull the cover downwards.
3. Replace the bulb (E14 socket) with one of the same power and specifically designed for household appliances. (the maximum power is shown on the light diffuser).
4. Reconnect the appliance.

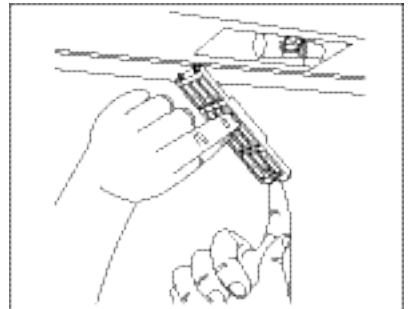

## Closing the door

1. Clean the door gaskets.
2. If necessary, adjust the door. Refer to "Installation".
3. If necessary, replace the defective door gaskets. Contact the Service Center.

## Technical data

|             |        | QT3619FX QT3619K | QT3549W QT3549FX<br>QT3549K |
|-------------|--------|------------------|-----------------------------|
| Dimension   |        |                  |                             |
|             | Height | 1800 mm          | 1800 mm                     |
|             | Width  | 595 mm           | 595 mm                      |
|             | Depth  | 650 mm           | 650 mm                      |
| Rising Time |        | 10 h             | 10 h                        |

The technical information are situated in the rating plate on the internal left side of the appliance and in the energy label.

| Water pressure range                               |  |
|--|--|
| The water pressure must be at least 1 bar (100kPa) | Consult your installer if water pressure is less than 1 bar.   |
| Highest allowed water pressure 10 bar (1000kPa)    | If water pressure exceeds 10 bar a reduction valve must be fitted (available from your specialist shop). |



### WARNING!

Do not connect the appliance in spaces where ambient temperature can decrease to below freezing.

The appliance may only be connected to drinking water supplies.

The appliance may only be connected to cold water supplies.

## Installation



### WARNING!

Read the "Safety Information" carefully for your safety and correct operation of the appliance before installing the appliance.

## Positioning

Install this appliance at a location where the ambient temperature corresponds to the climate class indicated on the rating plate of the appliance:



| Climate class | Ambient temperature |
|---------------|---------------------|
| SN            | +10°C to + 32°C     |
| N             | +16°C to + 32°C     |
| ST            | +16°C to + 38°C     |
| T             | +16°C to + 43°C     |

## Location

To ensure best performance, if the appliance is positioned below an overhanging wall unit, the minimum distance between the top of the cabinet and the wall unit must be at least 40 mm. Ideally, however, the appliance should not be positioned below overhanging wall units.

If the cabinet is placed in a corner and the side with the hinges facing the wall, the distance between the wall and the cabinet must be at least 230 mm to allow the door to open enough so that the equipment can be removed.

The ventilation space can be:

- directly above the appliance
- behind and above the top cupboard.

In this case, the space behind the top cupboard must be at least 50 mm deep.

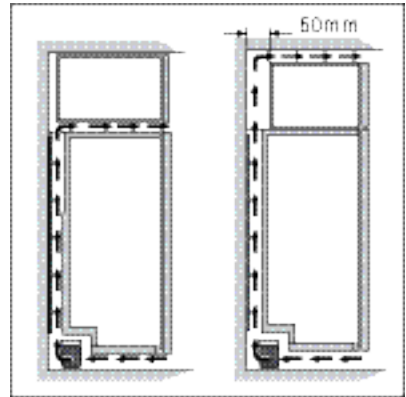

## Electrical connection

Before plugging in, ensure that the voltage and frequency shown on the rating plate correspond to your domestic power supply.

The appliance must be earthed. The power supply cable plug is provided with a contact for this purpose. If the domestic power supply socket is not earthed, connect the appliance to a separate earth in compliance with current regulations, consulting a qualified electrician. The manufacturer declines all responsibility if the above safety precautions are not observed.

This appliance complies with the E.E.C. Directives.

## Removing the transport support

Your appliance is equipped with transport support to secure the door during transportation. To remove them do these steps:

1. Open the door.
2. Remove the transport support from the door sides.
3. Remove the transport support from the lower hinge (some models).



Some models are fitted with a silencing pad under the cabinet. Do not remove this pad.

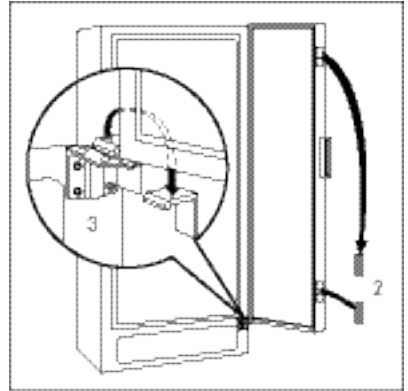

## Rear spacers

Install the spacers provided within the accessory bag as shown in the figure.

Install two spacers on the back side of the panel and two spacers with adhesive on the lower part.

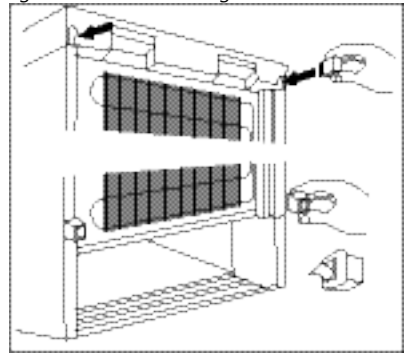

## Connecting the water hose.

Water supply should be provided with a tap and 3/4" male connector within 1,5 m from the appliance.

This work is to be carried out by a skilled plumber.

There are different type-approved taps and tap assemblies on the market.

The water hose must not be cracked, squeezed or put in tight bends.

Before the appliance is placed its final location, ensure that the water connection has been correctly carried out, that there is no leakage at the connection to the water tap.

Tighten the screw enough by hand.

Make sure that the gasket is properly positioned in the connector.

We recommend that the appliance is placed on a "run-off" mat intended for refrigerators and freezers, which makes it easier to detect possible leakage

## Levelling

When placing the appliance ensure that it stands level. If necessary adjust the feet using the adjustment spanner supplied.

Door alignment is dependent on proper levelling.

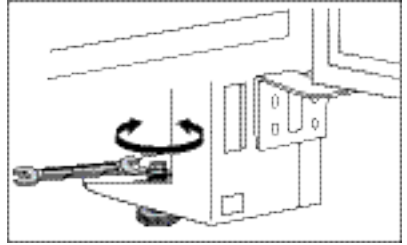

## Starting the ice maker for the first time.

Ensure proper connection to the water supply, refer to "Connecting the water hose".

1. Open the tap on the water connection.
2. Start the freezer and the ice maker starts automatically.

It will start filling water when the temperature is sufficiently low.

Do not use ice produced during the first day to ensure fresh taste.

## Door reversibility

It is not possible to change the opening direction of the door.

The water supply goes through the hinge to the water dispenser. Contact your dealer for more information.

## Environmental concerns

The symbol  on the product or on its packaging indicates that this product may not be treated as household waste. Instead it should be taken to the appropriate collection point for the recycling of electrical and electronic equipment. By ensuring this product is disposed of correctly, you will help prevent potential negative consequences for the environment and human health, which could otherwise be caused by inappropriate waste handling of this product. For more detailed information about recycling of this product, please contact your local council, your household waste disposal service or the shop where you purchased the product.

