



Thank You for purchasing this

Factory Service Manual on EBAY

from PCTECHINFO!



[Click Here](#) for more Factory Service

Manuals for other Computer and

Printer / Copier Manufacturers

from PCTECHINFO!

OKIDATA
an OKI AMERICA company

Microline 590/591

Service Handbook

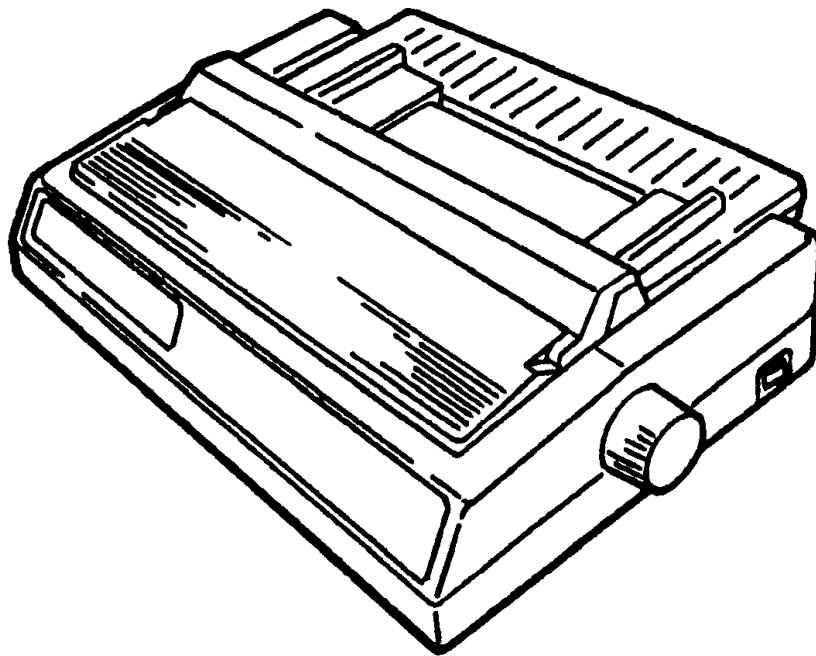

OKI

P/N 59256303

Microline 590/591
Service Handbook

This document may not be reproduced without the written permission of the Okidata Technical Training Group. Every effort has been made to ensure the accuracy of the information contained in this training course. Okidata is not responsible for errors beyond its control.

© 1994 by Okidata All rights reserved.

First Edition	October, 1992	P/N 59256301
Second Revision	March, 1993	
Third Revision	August, 1993	
Second Edition	April, 1994	P/N 59256302
Fourth Revision	April, 1994	
Third Edition	November, 1994	P/N 59256303

Written and produced by the Okidata Technical Training Group

Please address any comments on this publication to:

Technical Training Group

Okidata

532 Fellowship Road

Mount Laurel, NJ 08054-3499

Fax Number: (609) 235-2600, ext. 7034

Okilink Login Name: Technical Training

OKIDATA is a registered trademark of Oki Electric Industry Company, Ltd.; marques deposee de Oki Electric Industry Company, Ltd.; marca registrada, Oki Electric Industry Company, Ltd.

MICROLINE is a registered trademark of Oki Electric Industry Company, Ltd.; marque depose de Oki Electric Industry Company, Ltd.

OkiSmart Paper Handling is a trademark of Oki Electric Industry Company, Inc.

PLUG 'n PRINT is a registered trademark of Oki America, Inc.; marque deposee de Oki America, Inc.

Bitstream is a registered trademark of Bitstream Incorporated.

Epson is a registered trademark of Seiko Epson Corporation.

IBM is a registered trademark of International Business Machine Corporation.

MS-DOS is a registered trademark of Microsoft Corporation.

PC is a registered trademark of International Business Machine Corporation.

Proprinter is a registered trademark of International Business Machine Corporation.

Windows is a trademark of Microsoft Corporation

Table of Contents

COURSE ADMINISTRATION:

OVERVIEW	i-1
RECOMMENDATIONS	i-2
INFORMATION UPDATES.....	i-3
NOTICES.....	i-3
WHERE TO SEND TESTING MATERIALS	i-4
MISSING ITEMS OR MISSING PAGES.....	i-5
COURSE PATH	i-6
SERVICE TRAINING.....	i-7
SERVICE AUTHORIZATION	i-11
General Information.....	i-11
Answer Sheet: Microline 590/591	i-13
Course Critique: Microline 590/591	i-14
Certification Test: Microline 590/591.....	i-16

SECTION ONE: SPECIFICATIONS

1.1	OVERVIEW	1-1
	1.1.01 General Information.....	1-1
1.2	PHYSICAL SPECIFICATIONS	1-2
	1.2.01 Dimensions	1-2
	1.2.02 Printer Weight.....	1-2
1.3	POWER REQUIREMENTS.....	1-3
	1.3.01 Input Power.....	1-3
	1.3.02 Power Consumption.....	1-3
	1.3.03 Power Frequency	1-3
1.4	ENVIRONMENTAL CONDITIONS.....	1-4
	1.4.01 Acoustic Rating.....	1-4
	1.4.01 Altitude	1-4
	1.4.03 Ambient Temperature and Relative Humidity (RH).....	1-4

1.5	AGENCY APPROVALS.....	1-4
1.5.01	Listings.....	1-4
1.6	OPERATIONAL SPECIFICATIONS.....	1-5
1.6.01	Character Matrix Sizes.....	1-5
	Table of Print Speed and Character Matrix	1-5
1.6.02	Characters Per Line.....	1-5
	Microline 590.....	1-5
	Microline 591.....	1-5
1.6.03	Character Pitches	1-6
1.6.04	Character Sets	1-6
1.6.05	Printer Emulations	1-6
1.6.06	Fonts.....	1-7
	Letter Quality	1-7
	Draft.....	1-7
	Bar Code	1-7
1.6.07	Front Panel Switches.....	1-8
1.6.08	Graphics Resolution.....	1-8
1.6.09	Interface	1-8
	Standard	1-8
	Optional.....	1-8
1.6.10	Line Feed Increments.....	1-8
	Fixed	1-8
	Variable.....	1-8
1.6.11	Line Feed Time	1-8
1.6.12	Menu Mode.....	1-9
1.6.13	Paper Feed Methods.....	1-9
	Standard	1-9
	Optional.....	1-9
1.6.14	Paper Feed Paths	1-9
1.6.15	Paper Loading	1-9
1.6.16	Paper Out Detection.....	1-10
1.6.17	Paper Tear Capabilities	1-10
1.6.18	Print Method	1-11
	Printhead Type	1-11
	General Information.....	1-11
	Overheat Protection	1-11
	Printhead Gap Information.....	1-12
1.6.19	Print Modes	1-14
1.6.20	Print Speed.....	1-14
	Table of Print Speed and Character Matrix	1-14

1.7	PAPER SPECIFICATIONS	1-15
1.7.01	Types.....	1-15
	Card Stock.....	1-15
	Continuous Form	1-15
	Cut Sheet.....	1-16
	Envelopes.....	1-16
	Labels.....	1-17
	Transparency.....	1-17
1.7.02	Length.....	1-18
1.7.03	Number of Copies.....	1-18
1.7.04	Thickness	1-18
1.7.05	Weight.....	1-19
1.7.06	Width.....	1-19
	Paper	1-19
	Printing Area.....	1-19
1.8	MEMORY SPECIFICATIONS.....	1-20
1.8.01	EEPROM	1-20
1.8.02	ROM	1-20
1.8.03	RAM	1-20
1.9	CONSUMABLES.....	1-21
1.9.01	Ribbon.....	1-21
1.10	OPTIONS.....	1-22
1.10.01	Cut Sheet Feeders	1-22
1.10.02	Pull Tractor Kit	1-22
1.10.03	Color Ribbon Kit.....	1-22
1.10.04	Bottom Push Tractor Kit	1-23
1.10.05	Serial Interface	1-23
1.10.06	Roll Paper Stand	1-23
1.10.07	Bitstream Facelift 2.0.....	1-23
1.10.08	OKISmart Typer Utility	1-24
1.10.09	OKISmart Panel Utility.....	1-24
1.11	RELIABILITY.....	1-25
1.11.01	Mean Time Before Failure (MTBF)	1-25
1.11.02	Mean Time To Repair (MTTR)	1-25
1.11.03	Printer Life	1-25
1.11.04	Printhead Life.....	1-25
1.11.05	Ribbon Life	1-25
1.11.06	Warranty (Limited)	1-25
1.11.07	Service.....	1-25

SECTION TWO: PRINCIPLES OF OPERATION

2.1	ELECTRICAL OPERATION.....	2-1
2.1.01	General Information.....	2-1
2.1.02	Main Control Board.....	2-1
	Microprocessor (MPU).....	2-1
	Block Diagram.....	2-2
	Program ROM.....	2-3
	RAM.....	2-3
	Character Generator ROM (CG ROM).....	2-4
	Electrically Erasable Programmable ROM (EEPROM).....	2-4
	LSI.....	2-5
2.1.03	Initialization.....	2-6
2.1.04	Parallel Interface Control.....	2-7
2.1.05	Print Control.....	2-8
	LSI/Printhead Interface.....	2-8
	Gap Adjust Control.....	2-9
	Print Compensation Control.....	2-9
2.1.06	Space and Line Feed (SP/LF) Motor Control.....	2-10
	Line Feed Motor Control.....	2-10
	Space Motor Control.....	2-11
	Encoder Disk.....	2-11
2.1.07	Operation Panel.....	2-12
2.1.08	Alarm Circuit.....	2-14
	Driver Circuit Alarm Processing.....	2-14
	Low Motor Drive Voltage Alarm.....	2-14
	Head Drive Time.....	2-15
	Print Speed.....	2-15
	Head Overheat Alarm Processing.....	2-15
2.1.09	Power Supply Circuit.....	2-16
	Table of Output Voltages.....	2-16
2.2	MECHANICAL OPERATION.....	2-17
2.2.01	Printhead Mechanism.....	2-17
	Printhead Gap Information.....	2-18
	Interconnect Diagram: Control Board to Printhead.....	2-20
	Line Feed Motor Resistance.....	2-21
	Space Motor Resistance.....	2-21
	Printhead Operation.....	2-22
2.2.02	Spacing Mechanism.....	2-24
	Spacing Operation.....	2-24

2.2.03	Head Gap Mechanism.....	2-26
	Head Gap Setting Operation	2-26
2.2.04	Ribbon Drive Mechanism	2-28
	Black Ribbon Drive Operation	2-28
	Color Ribbon Shift Mechanism	2-29
2.2.05	Line Feed Mechanism.....	2-30
	Change Lever (Paper Path Selection Lever)	2-30
	Paper Clamp Mechanism	2-30
	Cut Sheet/Continuous Sheet Switching Mechanism.....	2-31
	Top Feed (for cut sheet paper)	2-31
	Rear/Bottom Feed (for continuous feed paper).....	2-31
	Cut Sheet Paper Feed Operation	2-32
	Continuous Paper Feed (Rear Tractor Mechanism).....	2-32
	Continuous Paper Feed (Pull Tractor Mechanism)	2-32
	Continuous Paper Feed (Bottom Tractor Feed Mechanism)	2-33
	Continuous Paper Feed (Push/Pull Tractor Mechanism)	2-33
2.2.06	Paper Detection Mechanism	2-34
	Top Feed Paper Detection.....	2-34
	Rear Feed Detection.....	2-34
	Bottom Feed Detection	2-34
2.2.07	Support Protector Mechanism.....	2-35
2.2.08	Automatic Paper Load	2-36
	Cut Sheet Paper.....	2-36
	Continuous Feed Paper	2-37
2.2.09	Paper Park	2-38
	Paper Park Operation	2-38

SECTION THREE: MAINTENANCE

3.1	OVERVIEW	3-1
	3.1.01 General Information.....	3-1
	3.1.02 Maintenance Tools.....	3-1
	3.1.03 Maintenance Precautions	3-2
3.2	DISASSEMBLY/ASSEMBLY PROCEDURES	3-3
	General Information.....	3-3
	3.2.01 Preliminary Items.....	3-4
	3.2.02 Printhead Assembly	3-6
	3.2.03 Ribbon Protector	3-8
	3.2.04 Gear Case Assembly	3-10
	3.2.05 Pull-up Roller Assembly	3-12
	3.2.06 Upper Cover, Access Cover, and Sheet Guide Assemblies.....	3-14

3.2.07	Control Board (AKGI)	3-16
3.2.08	Power Supply Assembly	3-18
3.2.09	Operator Panel PCB (LEOP)	3-20
3.2.10	PC Connector	3-22
3.2.11	Space Motor and Roller Guide Assemblies	3-24
3.2.12	Carriage Cable	3-26
3.2.13	Space Rack.....	3-28
3.2.14	Roller/Holder Backup Assembly	3-30
3.2.15	Guide Rail and Adjust Cam	3-32
3.2.16	Left Ground Plate.....	3-34
3.2.17	Right Ground Plate	3-36
3.2.18	Rear and Cut Sheet Paper Feed Sensor Levers.....	3-38
3.2.19	Platen Assembly.....	3-40
3.2.20	Paper Chute Assembly	3-42
3.2.21	Line Feed Motor Assembly	3-44
3.2.22	Reset Spring	3-46
3.2.23	Idle Gear and Change Lever	3-48
3.2.24	Pressure Spring	3-50
3.2.25	Carriage Shaft	3-52
3.2.26	Leaf Spring.....	3-54
3.2.27	Bottom Paper Sensor Levers.....	3-56
3.2.28	Front Pressure Roller Assembly	3-58
3.2.29	Tractor Assembly.....	3-60
3.2.30	Main Frame.....	3-62
3.3	PRINTER ADJUSTMENTS	3-65
3.3.01	General Information.....	3-65
3.3.02	Printhead Gap Adjustment.....	3-66
	General Information.....	3-66
	Procedure	3-68
	Setup Phase	3-68
	Printhead Gap Modification Phase	3-68
	Parallel Adjustment Phase	3-68
	Recheck Phase	3-68
3.3.03	Key Combinations	3-70
3.3.04	Menu Operation	3-71
	General Information.....	3-71
	Menu Mode.....	3-71
	Printing the Menu	3-72
	Sample Menu	3-73
	Reset Menu to Factory Defaults	3-75

Limited Operation.....	3-76
General Information.....	3-76
Procedure	3-77
Menu Settings	3-78
3.3.05 Top of Form.....	3-82
General Information.....	3-82
Setting Top of Form.....	3-82
Reset the Top of Form to Factory Default.....	3-82
3.3.06 Paper Park.....	3-83
General Information.....	3-83
Procedure: Continuous Feed to Single Sheet.....	3-83
Procedure: Single Sheet to Continuous Feed.....	3-83
3.3.07 Tear Feature	3-85
General Information.....	3-85
3.3.08 Forms Tear Off	3-86
General Information.....	3-86
Setting.....	3-87
Using.....	3-87
Checking Top of Form with Form Tear Off Activated.....	3-87
3.3.09 Resets.....	3-88
Reset Menu to Factory Defaults	3-88
Reset the Top of Form to Factory Default.....	3-88
3.4 CLEANING	3-89
3.4.01 General Information.....	3-89
3.4.02 Cleaning Schedule	3-89
3.4.03 Cleaning Tools	3-89
3.4.04 Areas to be Cleaned	3-89
3.5 LUBRICATION	3-90
3.5.01 General Information.....	3-90
3.5.02 Lubrication Schedule	3-90
3.5.03 Lubrication Types	3-90
3.5.04 Lubrication Amounts	3-90
3.5.05 Lubrication Table.....	3-91
3.5.06 Areas Not Lubricated.....	3-91
3.6 SHIPPING INSTRUCTIONS.....	3-92
3.6.01 Return for Service.....	3-92
3.6.02 All Other Returns.....	3-93

SECTION FOUR: FAILURE ANALYSIS

4.1	OVERVIEW	4-1
4.1.01	Introduction.....	4-1
4.1.02	Printer Serial Number Identification.....	4-3
4.2	REPORTING PROBLEMS	4-4
4.2.01	General Information.....	4-4
4.2.02	Problem Lists	4-4
4.2.03	Reporting Methods.....	4-5
	Okilink II.....	4-5
	Course Critique	4-5
	Fax Number	4-5
	Mailing Address.....	4-5
	Information Provided.....	4-5
4.3	TROUBLESHOOTING UPDATES.....	4-6
4.3.01	General Information.....	4-6
4.3.02	Okilink II.....	4-6
4.3.03	Faxable Facts	4-6
4.3.04	Technical Service Bulletins	4-6
4.4	TROUBLESHOOTING TIPS.....	4-7
4.4.01	Preliminary Checks.....	4-7
4.4.02	Problem Categories	4-8
	ALARM Lamp Blinks (Fatal Errors).....	4-8
	Operational Errors.....	4-8
	ALARM Lamp Lights (Paper End/Jam Conditions)	4-8
4.4.03	START HERE Flowchart	4-9
4.4.04	Tips for Preventing Image Problems	4-10
4.4.05	Common Problems.....	4-11
4.5	ABNORMAL OUTPUT	4-14
4.5.01	Output Samples.....	4-14
	Light Print on the Entire Page.....	4-15
	Uneven Print Density	4-15
	Smearred Print.....	4-15
	Inconsistent Line Feed	4-15
	Drifting Margin.....	4-15
	Left Margin Drifting Problem.....	4-17

4.6	FAULT ALARMS	4-18
4.6.01	General Information.....	4-18
4.6.02	ALARM/LED Display Troubleshooting Table Index	4-19
4.6.03	ALARM/LED Display Troubleshooting Tables.....	4-20
4.7	REPAIR ANALYSIS PROCEDURES (RAPs).....	4-22
4.7.01	Using the RAPs.....	4-22
4.7.02	RAP Index.....	4-23
	RAP 01 No Power Supplied to Printer.....	4-24
	RAP 02 No Spacing Operation	4-26
	RAP 03 Printhead Homing Error	4-28
	RAP 04 Paper Jam During Paper Loading	4-30
	RAP 05 Printhead Pins Not Firing.....	4-31
	RAP 06 Poor Print Quality.....	4-32
	RAP 07 Ribbon Feed Problem.....	4-33
	RAP 08 Line Feed Problem	4-34
	RAP 09 Operation Panel Malfunction	4-37
	RAP 10 Parallel Interface Problem.....	4-38
	RAP 11 Serial Interface Problem.....	4-40
4.8	PRINTER TESTS	4-43
4.8.01	General Information.....	4-43
4.8.02	Rolling ASCII Test	4-44
	General Information.....	4-44
	Procedure	4-44
	Sample.....	4-45
4.8.03	Font Test	4-46
	General Information.....	4-46
	Procedure	4-46
	Sample.....	4-47
4.8.04	Serial Interface Loopback Test	4-48
	Loopback Connector Configuration	4-49
	Serial Cable Information.....	4-50
	Serial Interface Signal Requirements.....	4-50
	Commonly Used Serial Cable Configurations.....	4-51
	IBM 25-Pin Cable Configuration.....	4-51
	IBM 9-Pin Cable Configuration.....	4-51

4.8.05	Hexadecimal Dump Mode	4-52
	General Information	4-52
	Example	4-52
	Procedure	4-52
	Sample	4-53
4.9	RESISTANCE CHECKS	4-54
4.9.01	General Description	4-54
	Layout Diagram	4-55
4.9.02	Printhead	4-56
	Interconnect Diagram: Control Board to Printhead	4-56
4.9.03	Line Feed Motor Resistance	4-57
4.9.04	Space Motor Resistance	4-57

APPENDIX A: BOARD DIAGRAMS

A.1	OVERVIEW	A-1
A.1.01	General Information	A-1
A.2	INDEX TO CHARTS	A-2
A.2.01	Main Controller Board (AKGI)	A-4
A.2.02	Operator Panel Board (LEOP)	A-6
A.2.03	Power Supply Assembly	A-8
A.2.04	Space Motor Board	A-10
A.2.05	RS232-C Serial Interface Board (LXHI) Option	A-12

APPENDIX B: ILLUSTRATED PARTS LISTING

B.1	OVERVIEW	B-1
B.1.01	General Information	B-1
	Format	B-2
	Current Part Numbers	B-3
B.1.02	Definition of Terms	B-4
	Assemblies	B-4
	Blank	B-4
	Consumable	B-4
	Document	B-4
	Drivers	B-4
	Firmware	B-4
	Option	B-4
	Option RSPL	B-4
	RSPL	B-4
	Technical Service Bulletins	B-5

590.....	B-5
591.....	B-5
Both.....	B-5
B.1.03 Parts Ordering Information	B-6
Service Center Reference Guide	B-6
Placing a Parts Order	B-7
B.2 CHARTS.....	B-8
B.2.01 Printer.....	B-10
B.2.02 Upper Cover Assembly.....	B-12
B.2.03 Printer General Assembly	B-14
B.2.04 Printer Unit (1 of 3).....	B-16
B.2.05 Printer Unit (2 of 3).....	B-18
B.2.06 Printer Unit (3 of 3).....	B-20
B.2.07 Carriage Assembly.....	B-22
B.2.08 Options.....	B-24
B.2.09 Option Parts	B-26
B.2.10 Consumables	B-28
B.2.11 Packing Materials.....	B-30
B.2.12 Documentation.....	B-32
B.2.13 Service Training Kit Revision List	B-34

This page was intentionally left blank.

COURSE ADMINISTRATION

OVERVIEW

Okidata developed this course in order to provide the information necessary to install and maintain the Microline 590 and Microline 591 printers. Upon successful completion of this training course, you will be able to do the following.

- Install and operate the product
- Locate the major assemblies of the product
- Identify fault indications
- Perform corrective and preventive maintenance

The Service Handbook is the primary reference manual for this course. You cannot, however, successfully complete this course by referring only to this manual. Take the time to familiarize yourself with all of the documentation in the training kit. This additional information will greatly simplify working with the product.

Okidata's Technical Training Program is designed to build a knowledgeable and efficient service and support group for Okidata products.

One step in becoming an Authorized Okidata Service Center is obtaining a training kit for the appropriate product. This acquisition allows the Dealership to have reference materials available during service jobs. Having, and using, these reference materials will minimize the time and money spent on repairs.

Technicians complete Certification Tests as part of Okidata's Authorization process. Testing familiarizes the technician with the product and reference materials.

This training course provides *assembly level* repair information to the field technician. No attempt is made to provide basic training in being a technician. This kit strives to train a technician to service the product. Okidata views service technicians as representatives of Okidata. Through this course, Okidata seeks to provide the means and the motivation that will make good service a reality.

Remember

Component level servicing is provided only at Okidata Service Repair Depots!

RECOMMENDATIONS

Prerequisites

Before beginning this course, you should know the following concepts.

Have an understanding of basic electronics

Be familiar with electrostatic principles

Be familiar with dot matrix technology and protocol

Be familiar with the proper procedures for handling circuit boards, Read Only Memory (ROM), and Random Access Memory (RAM)

Be able to use basic tools

Be able to use a digital multimeter (DMM)

Equipment

The following equipment is recommended for the successful completion of this training course.

Microline 590 or Microline 591 (optional)

Tools (optional - refer to Module Three of the Service Handbook)

Personal Computer (for Okilink II connection)

Modem (for Okilink II connection)

Communications Software (for Okilink II connection)

Telephone (for Faxable Facts connection)

Facsimile Machine (for Faxable Facts connection)

Video Cassette Player (for viewing videotape)

Video Monitor (for viewing videotape)

Documentation

You should have access to the following documentation while completing this course.

Okidata Service Center Reference Guide

Service Handbook

Printer Handbook

Service Videotape

INFORMATION UPDATES

Every effort has been made to ensure the accuracy of the information contained in this training course. Okidata is not responsible for errors beyond its control.

Technical updates are made available to authorized Service Centers through the Technical Service Bulletins (TSBs / Okidata's Monthly Technical Mail). The TSBs are distributed via Okidata's Bulletin Board, Okilink II.

Additions and corrections to the training materials are available in the Training Section of Okilink II. Please sign on and check this section before beginning this course.

For information on using Okilink II, please refer to the Service Center Reference Guide.

NOTICES

Pay attention to all notices that appear throughout this training course. They are for your safety! Here are the definitions of the notices.

NOTE:

This notice refers to supplemental information.

CAUTION:

Deviation from the listed procedures may result in damage to the product.

WARNING:

Deviation from the listed procedures may result in personal injury.

WHERE TO SEND TESTING MATERIALS

Refer to the Okidata Service Center Reference Guide for where to send the test materials.

The Okidata Service Center Reference Guide is sent to your dealership along with the Okidata Service Contract materials. It is available from Okidata Dealer Service. It is also available through Okilink II.

MISSING ITEMS OR MISSING PAGES

Missing Items

When you receive the training kit, you *MUST* verify that the kit contains the items listed on the Read Me First sheet.

If any items are missing, please contact Okidata Logistics at the appropriate number listed below.

Facsimile 1-609-424-7423

Voice 1-800-727-8654

You must provide the following information.

- Okidata Authorization Number (Dealer Number)
- Okidata Customer Number
- Order Acknowledgment Number (on the invoice)
- Part Number of kit

Missing Pages

If you find that *pages* are missing from any item in this kit, please contact Okidata Technical Training.

Please FAX your request or use Okilink II.

Fax Number: (609) 235-2600, ext. 7034

Okilink Login Name: Technical Training

You must provide the following information.

- Okidata Authorization Number (Dealer Number)
- Part Number of document with missing pages
- Name of document with missing pages
- Page numbers of missing pages

If it is the Service Handbook, be sure to specify the section (i, 1, 2, 3, 4, a, or b).

- Your facsimile number (with area code)

COURSE PATH

This Course Administration directs you through the training package. Each section covers a different part of the training. Tasks within each section direct you to the portions of the training materials that cover the subject you are studying.

When you have completed one section, move on to the next. You must achieve a score of 80% or greater on your Certification Test to successfully complete this course.

You must return your completed Certification Test Answer Sheet and Course Critique to Okidata within 30 days after the kit is received by your Dealership. If multiple technicians are training at your Dealership, only one technician must complete the testing during the 30 days.

DO NOT STAPLE THE ANSWER SHEET TO THE COURSE CRITIQUE!

Be sure to make a copy of the Answer Sheet for your records.

Your Answer Sheet will be corrected within two days after it is received by Okidata. If you achieve a score of 80% or higher, you will receive a Certificate of Training. The Dealership you work for will become an Authorized Service Center for the products covered in this training package.

Service Authorization is approved once Okidata processes the Answer Sheet. The Certificate of Training will be mailed to you after the Answer Sheet is corrected.

You and your Dealership are responsible for returning the Answer Sheet and Course Critique within 30 days after receiving the training kit. Okidata strongly urges you to keep track of the date you return your Answer Sheet and Course Critique. Certification and Authorization are processed within two days after Okidata receives the testing materials. A certificate for successful completion of the training program will be sent to you within 21 days. If authorization is not updated within two days or a certificate received within 21 days, contact Okidata Dealer Service.

Proceed through each section and perform the assigned tasks.

Learn from the Course and Good Luck!

SERVICE TRAINING

Requirements

You will need the following items.

- Service Center Reference Guide
- Service Handbook
- User's Documentation
- Service Videotape
- Video Cassette Player and Monitor

Service Training is divided into the following six sections.

- General Description
- Installation
- Principles of Operation
- Failure Analysis
- Appendices
- Maintenance
 - Disassembly/Assembly
 - Adjustments and Service Checks
 - Cleaning
 - Lubrication
 - Shipping Instructions

General Description

This section describes the features and specifications of the printers.

Assigned Tasks

- Read Section 1 of the Service Handbook.
- Read Appendix A in the Printer Handbook.

Installation

In this section, you will install the unit. You will also perform various tests.

Assigned Tasks

- Review the Printer Handbook
- Read the Introduction; Chapters 1, 2, 3, 4, and 5; and Appendices B, C, D, E, and F in the Printer Handbook.
- If a product is available, perform the tests listed below. Refer to Section 4 of the Service Handbook.

Rolling ASCII

Font Test

Principles of Operation

This section describes the function of the major assemblies from an electrical and mechanical perspective.

Assigned Tasks

- Read Section 2 of the Service Handbook.

Failure Analysis

This section covers the methods used to identify and correct problems with the unit.

Assigned Tasks

- Read Section 4 of the Service Handbook.
- Read Chapter 6 of the Printer Handbook.
- Study the Board Diagrams in Appendix A of the Service Handbook.
- Check Okilink II for additional troubleshooting information. Refer to the Service Center Reference Guide for information on accessing Okilink II.

Appendices A and B

Appendices A and B contain charts, illustrations, and an illustrated parts list to support you in servicing the product.

Appendix A

Appendix A contains information about the printed circuit boards (PCBs). This appendix includes reference charts which present data regarding function, firmware, fuses, jumpers, sensors, switches, and test points. An illustration of each board is also included.

Appendix B

Appendix B is an illustrated parts listing of the product. This listing is cross-referenced to Section 3 of the Service Handbook.

Assigned Tasks

- Look through Appendix A and Appendix B in the Service Handbook.

Maintenance

Disassembly / Assembly

Assigned Tasks

- Read Section 3.2 of the Service Handbook.
- View the videotape.

CAUTION:

Okidata does not recommend performing the disassembly / assembly procedures on a product which is operating normally. Therefore, you are not required to perform the disassembly / assembly procedures to complete this training.

Adjustments and Service Checks

This section explains the adjustments performed after parts replacement. Hardware replacement may require adjustments to firmware settings. This section also explains viewing and resetting counters.

Assigned Tasks

- Read Section 3.3 of the Service Handbook.
- Perform the procedures listed in Section 3.3 of the Service Handbook.

Cleaning

Assigned Tasks

- Read Section 3.4 of the Service Handbook.

Lubrication

Assigned Tasks

- Read Section 3.5 of the Service Handbook.

Shipping Instructions

Assigned Tasks

- Read Section 3.6 of the Service Handbook.

SERVICE AUTHORIZATION

General Information

Read through the instructions for completing the testing process before you begin.

This section contains the Answer Sheet, Certification Test, and Course Critique for this service training package. These are the only copies of these items you will receive.

DO NOT WRITE ON THESE ITEMS!

PHOTOCOPY EACH ITEM!

Use the photocopies to complete the testing process. Photocopy the Certification Test, Answer Sheet, and Course Critique as required for each technician being trained.

The information provided on the Answer Sheet and Course Critique is used to update your Dealership's Okidata Service Warranty Profile and to process your Certificate of Training. The critique information is used to respond to your questions regarding this training package.

MAKE YOUR RESPONSES COMPLETE AND LEGIBLE!

Feel free to reference the training material as you answer the test questions.

Every attempt has been made to test your knowledge of the product and your ability to use the reference materials in this kit. No attempt has been made to write "trick questions".

If you have a question about a specific test question or answer, please bring it to the attention of Okidata Technical Training. Refer to the Service Center Reference Guide for information on contacting Okidata Technical Training.

In order to improve the quality of future training courses, Okidata welcomes your evaluation of this training program. Please complete the course critique for this training course.

Before returning your completed testing materials, photocopy your completed Answer Sheet for your records.

DO NOT ATTACH ANYTHING TO THE ANSWER SHEET!

Certification Test

Requirements

You must achieve a score of 80% or greater on your Certification Test to successfully complete this course.

You will need the following items.

Service Handbook

User's Documentation

#2 Lead Pencil

Assigned Tasks

- Read through all instructions *BEFORE* completing the testing process.
- Photocopy the Certification Test and Answer Sheet provided in this kit. Use the photocopies to complete the testing process.
- Complete the top section of the Answer Sheet. Make your responses legible.
- Answer the Certification Test Questions by filling in the appropriate block on the Answer Sheet. Use a Number 2 pencil and completely fill in the selected block.

DO NOT ATTACH ANYTHING TO THE ANSWER SHEET!

- Make a copy of the completed Answer Sheet for your records.

Course Critique

Requirements

You will need the following items.

Your photocopy of the Course Critique

Assigned Tasks

- Complete the Course Critique.
- Return the Answer Sheet and Course Critique to Okidata Dealer Service.

DO NOT ATTACH ANYTHING TO THE ANSWER SHEET!

DATE ITEMS RETURNED TO OKIDATA: _____

Answer Sheet: Microline 590/591

Section 1

Dealer Code: _____ Today's Date: _____

Technician's Name: _____

Company: _____

Company's Address: _____

City: _____

State/Province: _____

Zip/Postal Code: _____

Country: _____

Phone #: _____ Fax #: _____

If your Dealership uses Okilink II, please provide your Dealership's Login Name.

First: _____ Last: _____

Section 2

	<u>A</u>	<u>B</u>	<u>C</u>	<u>D</u>		<u>A</u>	<u>B</u>	<u>C</u>	<u>D</u>
1.	<input type="checkbox"/>	<input type="checkbox"/>	<input type="checkbox"/>	<input type="checkbox"/>	11.	<input type="checkbox"/>	<input type="checkbox"/>	<input type="checkbox"/>	<input type="checkbox"/>
2.	<input type="checkbox"/>	<input type="checkbox"/>	<input type="checkbox"/>	<input type="checkbox"/>	12.	<input type="checkbox"/>	<input type="checkbox"/>	<input type="checkbox"/>	<input type="checkbox"/>
3.	<input type="checkbox"/>	<input type="checkbox"/>	<input type="checkbox"/>	<input type="checkbox"/>	13.	<input type="checkbox"/>	<input type="checkbox"/>	<input type="checkbox"/>	<input type="checkbox"/>
4.	<input type="checkbox"/>	<input type="checkbox"/>	<input type="checkbox"/>	<input type="checkbox"/>	14.	<input type="checkbox"/>	<input type="checkbox"/>	<input type="checkbox"/>	<input type="checkbox"/>
5.	<input type="checkbox"/>	<input type="checkbox"/>	<input type="checkbox"/>	<input type="checkbox"/>	15.	<input type="checkbox"/>	<input type="checkbox"/>	<input type="checkbox"/>	<input type="checkbox"/>
6.	<input type="checkbox"/>	<input type="checkbox"/>	<input type="checkbox"/>	<input type="checkbox"/>	16.	<input type="checkbox"/>	<input type="checkbox"/>	<input type="checkbox"/>	<input type="checkbox"/>
7.	<input type="checkbox"/>	<input type="checkbox"/>	<input type="checkbox"/>	<input type="checkbox"/>	17.	<input type="checkbox"/>	<input type="checkbox"/>	<input type="checkbox"/>	<input type="checkbox"/>
8.	<input type="checkbox"/>	<input type="checkbox"/>	<input type="checkbox"/>	<input type="checkbox"/>	18.	<input type="checkbox"/>	<input type="checkbox"/>	<input type="checkbox"/>	<input type="checkbox"/>
9.	<input type="checkbox"/>	<input type="checkbox"/>	<input type="checkbox"/>	<input type="checkbox"/>	19.	<input type="checkbox"/>	<input type="checkbox"/>	<input type="checkbox"/>	<input type="checkbox"/>
10.	<input type="checkbox"/>	<input type="checkbox"/>	<input type="checkbox"/>	<input type="checkbox"/>	20.	<input type="checkbox"/>	<input type="checkbox"/>	<input type="checkbox"/>	<input type="checkbox"/>

Course Critique: Microline 590/591

Dealer Code: _____ Today's Date: _____

Technician's Name: _____

Company: _____

Company's Address: _____

City: _____

State/Province: _____

Zip/Postal Code: _____

Country: _____

Phone #: _____ Fax #: _____

1. Have you completed other Okidata Self-Study Service Training packages?

Yes _____ No _____

2. Please rate this course.

Excellent _____ Below Average _____
Above Average _____ Poor _____
Average _____

3. Does your Dealership use Okilink II?

Yes _____ No _____

If yes, please provide your Dealership's Login Name.

First Name: _____

Last Name: _____

Certification Test: Microline 590/591

1. After installing the space motor assembly, Okidata recommends that you check the printhead gap adjustment.
 - A. True
 - B. False

2. Refer to RAP 01. After turning on the AC power switch, the next thing you should do is
 - A. replace the fuse.
 - B. check the AC cable to see if it is correctly connected.
 - C. replace the space motor assembly.
 - D. remove the printhead.

3. According to Appendix A in the Service Handbook, the +40 vdc needed for the printhead, space motor, and line feed motor drive can be verified at
 - A. CN8 Pins 8 and 9 on the main control board.
 - B. CN3 Pins 1 and 2 on the main control board.
 - C. CN8 Pins 1 and 2 on the main control board.
 - D. CN6 Pins 1 and 2 on the main control board.

4. Which of the following voltages is not supplied to the main control board?
- A. -12 vdc.
 - B. -8 vdc.
 - C. +8 vdc.
 - D. +40 vdc.
5. Which of the following is true about the Color Ribbon Kit for the Microline 590/591?
- A. It **MUST** be removed to use a black ribbon.
 - B. It **MUST** be installed by an Okidata certified service technician.
 - C. It **ONLY** includes the color mechanism. The ribbon **MUST BE** purchased separately.
 - D. It can be installed by the end user.

6. When the printhead temperature exceeds 110 degrees Celsius the printer will
- A. need replacing.
 - B. switch to unidirectional print.
 - C. alternate between unidirectional print and bi-directional print.
 - D. come to an immediate stop.
7. According to the Printer Handbook, the OkiSmart software is comprised of three programs which can be used instead of the printer's front panel to control and/or set many of the printer's parameters.
- A. True
 - B. False
8. Which of the following settings is *not* a factory default setting for the serial interface configuration?
- A. Parity - Even
 - B. Serial Data - 8 bits
 - C. Protocol - Ready/Busy
 - D. Baud Rate - 9600 bps

9. Which of the following FAULT ALARMS (displayed on the operator panel) indicates a PRINthead GAP ALARM?
- A. ALARM lamp flashing, UTILITY (ON), 10 cpi (ON), 20 cpi (ON).
 - B. ALARM lamp flashing, PROP (ON), PRESTIGE (ON).
 - C. ALARM lamp flashing, UTILITY (ON), 10 cpi (ON), SEL (ON).
 - D. ALARM lamp flashing, PROP (ON), 20 cpi (ON).
10. The customer states that the left margin position drifts during printing. Your first troubleshooting action is to
- A. replace the main control board.
 - B. make sure that the printhead cable connections are solid.
 - C. replace the space motor.
 - D. manually slide the carriage assembly to check for "drag".

11. What is the recommended ambient temperature and relative humidity (RH) for the Microline 590/591 while operating?
- A. 41°F to 104°F 20% to 80% (RH).
 - B. 41°F to 104°F 10% to 70% (RH).
 - C. 41°F to 104°F 20% to 50% (RH).
 - D. 41°F to 104°F 20% to 90% (RH).
12. The Rolling ASCII Test is a continuous printout of all ninety-six ASCII characters. Use this test to check
- A. left margin alignment.
 - B. that the correct data is being sent from the host computer.
 - C. the ability of the printer to select various fonts.
 - D. All of the above.

13. Which of the following is *not* part of the OkiSmart software programs?
- A. OKISmart Manager.
 - B. OKISmart Control.
 - C. OKISmart Panel Emulator.
 - D. OKISmart Setup.
14. Refer to RAP 02. After determining that the carriage is jammed and the ribbon is not jammed, your next step should be to
- A. install a new space motor.
 - B. turn the power Off, then On.
 - C. remove the space motor assembly and inspect the teeth on the space rack and space motor gear.
 - D. replace fuse F1 on the main controller board.

15. You are replacing the line feed motor assembly. The line feed idle gear is part of this assembly.

You can remove the line feed idle gear from the motor assembly **WITHOUT** breaking the claws.

The **EXACT SAME** gear can be re-installed.

- A. True
 - B. False
16. To reset **TOP OF FORM** to the factory default setting (1 inch), power **OFF** the printer. Then, press and hold the **QUIET** and **FORM FEED / Load** switches while powering **ON** the printer.
- A. True
 - B. False
17. Which of the following areas should be lubricated?
- A. Tractor pins
 - B. Pressure roller (Rubber Face)
 - C. Platen assembly (Rubber Face)
 - D. Visible bearings of gears of the gear case assembly

18. The printhead gap adjustment is set by turning the adjusting screw, located on the space motor assembly. Turning the adjusting screw counter-clockwise will increase the gap. Turning it clockwise will decrease the gap.
- A. True
 - B. False
19. Unexpectedly, the printer stops printing. The ALARM lamp is flashing. The 15 cpi LED is lit. According to the FAULT ALARM section of the Service Handbook, which of the following should be replaced *first*?
- A. Printhead and the main control board.
 - B. Line feed motor and space motor.
 - C. Interface (LXHI) board and the feed mechanism.
 - D. ROM and / or main control board

20. According to the Service Handbook, before resetting the printer menu to factory defaults, you should always
- A. run a self test.
 - B. perform the hex dump test.
 - C. print the menu.
 - D. perform the ASCII test.

**SECTION ONE
SPECIFICATIONS**

1.1 OVERVIEW

1.1.01 General Information

The Microline 590 and Microline 591 are letter quality dot-matrix printers which utilize *OKISMART* paper handling. Patented Okidata technology does away with the manual head gap adjustment. The Microline 590/591 actually "reads and learns" the media you feed in, then automatically adjusts the head gap to the optimum distance. This autogapping process leads to longer printhead life.

An optional, user-installable Color Kit (coupled with a customer-provided color software package) allows the printers to add impact to graphics, charts, transparencies and text presentations.

Additional options include the Bottom Feed Push Tractor, Cut-Sheet Feeder, Pull Tractor and Serial Interface Board.

The Microline 590 is an 80 column printer.

The Microline 591 is a 132 column printer.

Okidata's extended two year limited warranty covers the parts, labor and printhead on both printers.

The following items are included with the printer.

OKISMART Typewriter - software which provides the flexibility for the Microline 590/591 to function like a typewriter on checks, labels and envelopes.

OKISMART Panel - a utility program that lets you control selected printer functions from your personal computer.

Scalable Fonts - 14 scalable fonts, available on diskette.

NOTE:

The OkiSmart software includes three programs.

1. *OkiSmart Control*
2. *OkiSmart Panel Emulator*
3. *OkiSmart Setup*

Refer to the Printer Handbook for more information.

1.2 PHYSICAL SPECIFICATIONS

1.2.01 Dimensions

NOTE:

Dimensions INCLUDE the platen knob, acoustic cover, and paper separator.

Microline 590

Width: 18.35 inches (466 millimeters)

Depth: 17.24 inches (438 millimeters)

Height: 6.52 inches (165 millimeters)

Microline 591

Width: 24.41 inches (620 millimeters)

Depth: 17.24 inches (438 millimeters)

Height: 6.52 inches (165 millimeters)

1.2.02 Printer Weight

Microline 590

16.5 pounds (6.5 kilograms)

Microline 591

19.8 pounds (8.9 kilograms)

1.3 POWER REQUIREMENTS

1.3.01 Input Power

120 VAC: +5.5 / -15%

230/240 VAC: +10 / -14%

1.3.02 Power Consumption

Operating: 110 VA

Idle: 40 VA

1.3.03 Power Frequency

120 VAC: 60 Hz +/- 2%

230/240 VAC: 50/60 Hz +/- 2%

1.4 ENVIRONMENTAL CONDITIONS

1.4.01 Acoustic Rating

Letter Quality Mode: 53 dBA

Quiet Mode: 50 dBA

1.4.01 Altitude

10,000 feet (3,050 meters)

1.4.03 Ambient Temperature and Relative Humidity (RH)

While operating: 41° to 104° F (5° to 40° C)

Operating humidity: 20% to 80% RH

While in storage: 14° to 122° F (-10° to 50° C)

Storage humidity: 5% to 95% RH

1.5 AGENCY APPROVALS

1.5.01 Listings

UL No: UL Standard No. 1950

CSA No: CSA Standard 22.2-950

FCC: FCC Certified per Part 15, Subject J, Class B

IEC: IEC 950

VDE: VDE 0805 VDE 0875 Class B

BS: BS 7002

1.6 OPERATIONAL SPECIFICATIONS

1.6.01 Character Matrix Sizes

Table of Print Speed and Character Matrix

Mode	LQ	Utility	High Speed Draft
Speed	120 (12 cpi)	360 (12 cpi)	450 (15 cpi)
Matrix (H x V)	29 x 18	9 x 17	7 x 17

1.6.02 Characters Per Line

Microline 590

Characters Per Line	Characters Per Inch	Utility	Letter Quality
80	10	164	65
96	12	161	65
120	15	148	65
136	17.1	96	65
160	20	95	65

Microline 591

Characters Per Line	Characters Per Inch	Utility	Letter Quality
136	10	105	40
163	12	96	40
204	15	88	40
233	17.1	59	40
272	20	59	40

1.6.03 Character Pitches

5, 6, 8.5, 10, 12, 15, 17.1, 20

1.6.04 Character Sets

Standard ASCII

EPSON Character Set I & II

IBM Character Set I, II & All Characters

Foreign Character Substitution

International Character Sets

Code Page 850, 860, 863 and 865

Bar Code

Code 39

UPC A

UPC E

EAN 8

EAN 13

Interleaved 2 of 5

Code 128

POSTNET

1.6.05 Printer Emulations

NOTE:

The emulations are co-resident

Epson LQ

IBM XL 24E (AGM)

IBM Proprinter

1.6.06 Fonts

Letter Quality

Courier
Letter Gothic
Prestige
Orator
Roman
Swiss

Draft

Utility
High Speed Draft (15 cpi)

Bar Code

Code 39
UPC A
UPC E
EAN 8
EAN 13
Interleaved 2 of 5
Code 128
POSTNET

1.6.07 Front Panel Switches

Select	Micro Feed Up / Down
Menu Mode	Paper Park
Line Feed	Pitch Selection
Form Feed	Print Quality Selection
Top of Form	Tear
Quiet	

1.6.08 Graphics Resolution

Graphics Resolution: 360 x 360 DPI maximum

1.6.09 Interface

Standard

Parallel

Optional

RS232C Serial

1.6.10 Line Feed Increments

Fixed

6 lines per inch (lpi) [0.167 inch (4.23 millimeters)]

8 lines per inch (lpi) [0.125 inch (3.175 millimeters)]

Variable

n/60 inch

n/72 inch

n/180 inch

n/216 inch

n/360 inch

1.6.11 Line Feed Time

65 milliseconds 6 lines per inch (lpi)

6 milliseconds 8 lines per inch (lpi)

1 second 5.0 inches (Continuous paper feed rate)

1.6.12 Menu Mode

Print: Prints the entire menu.

Group: Selects Group Function

Item: Selects Item

Set: Selects Item Value

Exit: Exits Menu Mode, Enters Select

1.6.13 Paper Feed Methods

Standard

Friction Feed (Top)

Rear Push Tractor (Rear)

Optional

Pull Tractor (Bottom)

Bottom Push Tractor (Bottom)

Single-Bin Cut Sheet Feeder (Top)

CSF 5000 - Narrow

CSF 5001 - Wide

1.6.14 Paper Feed Paths

Top Feed (Standard)

Rear Feed (Standard)

Bottom Feed (by using an Optional feed mechanism)

Special Features

Paper Park

Automatic Paper Loading

Forms Tear Off

1.6.15 Paper Loading

Auto Loading (Top Feed)

Press LOAD switch for Bottom/Rear Feed

1.6.16 Paper Out Detection

Distance from end of paper

Rear Feed: 0.5 inches (12.7 mm)

Bottom Feed: 0.5 inches (12.7 mm)

Top Feed: 0.5 inches (12.7 mm)

1.6.17 Paper Tear Capabilities

Forms Tear-Off (sharp edge on access cover)

Metal Tear Bar (with optional bottom tractor unit)

1.6.18 Print Method

Printhead Type

General Information

Impact: Dot Matrix

24 pin printhead

.0079 inch (.20 millimeter) diameter pins

Overheat Protection

When printhead temperature exceeds 110 degrees Celsius, the printer stops bi-directional printing. Uni-directional printing begins.

If the temperature exceeds 115 degrees Celsius, printing stops.

Printing will resume when the printhead temperature drops below 115 degrees Celsius.

NOTE:

Refer to Section Two for more information on printhead operation.

Printhead Gap Information

Three items factor into printhead gap information.

1. Printhead Gap Adjustment

This is a SERVICE ADJUSTMENT made by a technician.

It is covered in Section 3.3 of this Service Handbook.

The Adjustment measures 0.014, +/- 0.001 inches (0.35, +/- 0.03 mm).

2. Printhead Gap Adjust

This is a MENU ITEM in the SET-UP Group.

It fine tunes the automatic setting of the printhead gap.

The settings are 0, 1, and -1.

0 is the factory default.

Use 1 to *darken* print (if output is *consistently light*).

Use -1 to *lighten* print (if output is *consistently dark*).

3. Gap Control

This is a MENU ITEM in *each* [Paper Feed] Group.

The Groups are REAR FEED, BOTTOM FEED, and TOP FEED.

Gap Control determines how the printhead gap is set.

The settings are listed below.

Auto Gap, Semi Auto Gap, 1, 2, 3, 4, 5, 6, 7, 8, 9

An explanation of each setting follows.

Auto Gap

This is the factory default.

Automatically determines paper thickness of the first page.

During single-sheet feed, each page's thickness is checked *while* a job is printing.

Semi Auto Gap

Similar to Auto Gap.

Automatically determines paper thickness of the first page.

During single-sheet feed, each page's thickness IS NOT checked "while" a job is printing.

1, 2, 3, 4, 5, 6, 7, 8, 9

Used when the same paper is used ALL of the time.

Bypasses the automatic head gap adjustment.

1 is the narrowest gap setting.

9 is the widest gap setting.

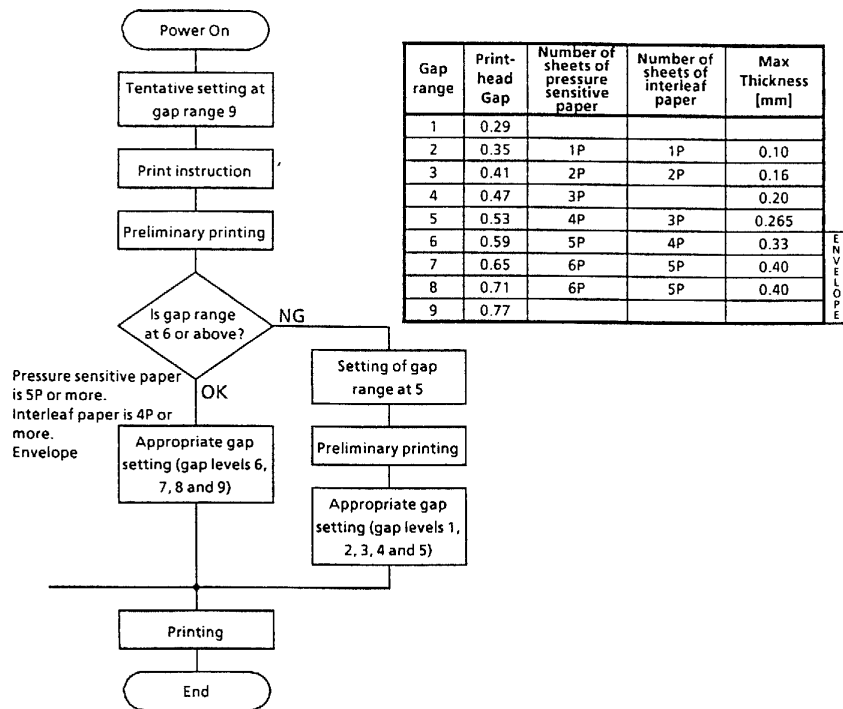

1-7-01.tif

1.6.19 Print Modes

Letter Quality

Utility

High Speed Draft

1.6.20 Print Speed

Table of Print Speed and Character Matrix

Mode	LQ	Utility	High Speed Draft
Speed	120 (12 cpi)	360 (12 cpi)	450 (15 cpi)
Matrix (H x V)	29 x 18	9 x 17	7 x 17

1.7 PAPER SPECIFICATIONS

CAUTION:

Use Bottom Feed and/or optional Pull Tractor for card stock and labels.

1.7.01 Types

Card Stock

Weight:	120 lbs. (450 g/m ²)	Maximum
Width:	Microline 590	5 to 8 inches (12.7 to 20.3 centimeters)
	Microline 591	5 to 14 inches (12.7 to 35.6 centimeters)
Length:	3 to 17 inches (7.62 to 43.18 centimeters)	
Thickness:	.017 inches (0.44 millimeters)	
Paper Feed Path:	Bottom	
Printhead Gap Information:	Refer to the Printhead Gap Information, Section 1.6	

Continuous Form

Weight:		
Single Part	12 - 24 lb. (45 to 90 g/m ²)	
Multi-Part, Carbonless	9 - 11 lb. (35 to 40 g/m ²)	
Multi-Part, Interleaf		
Paper	10 - 12 lb. (38 to 45 g/m ²)	
Carbon	9 lb. (35 g/m ²)	
Width:	Microline 590	3.5 to 10.5 inches (8.8 to 26.6 centimeters)
	Microline 591	3.5 to 16.5 inches (8.8 to 41.9 centimeters)
Length:	3 to 17 inches (7.62 to 43.18 centimeters)	
Thickness:	0.014 inches (0.36 millimeters)	Rear Feed
	0.017 inches (0.44 millimeters)	Bottom Feed
Paper Feed Path:	Rear or Bottom	
Printhead Gap Information:	Refer to the Printhead Gap Information, Section 1.6	

Cut Sheet

Weight:	12 to 24 lbs. (45 to 90 g/m ²)
Width:	7.2 to 14.3 inches (18.3 to 36.3 centimeters)
Width:	Microline 590 7.2 to 8.5 inches (18.2 to 21.5 centimeters)
	Microline 591 7.2 to 14.3 inches (18.2 to 36.3 centimeters)
Length:	3 to 17 inches (7.62 to 43.18 centimeters)
Thickness:	0.014 inches (0.325 millimeters) Maximum
Paper Feed Path:	Top
Printhead Gap Information:	Refer to the Printhead Gap Information, Section 1.6.

Envelopes

Weight:	24 lbs. (90 g/m ²) Maximum
Size:	
Single Feed	
Minimum:	6.5 x 3.6 inches (16.5 x 9.1 centimeters)
Maximum:	9.5 x 4.1 inches (24.1 x 10.4 centimeters)
Continuous	
Non-overlap type	
Thickness:	.014 inches (.325 millimeters) Maximum
Paper Feed Path:	Bottom
Printhead Gap Information:	Refer to the Printhead Gap Information, Section 1.6.

Labels

Weight:	N/A	
Width:	Microline 590	3.5 to 10.5 inches (8.8 to 26.6 centimeters)
	Microline 591	3.5 to 16.5 inches (8.8 to 41.9 centimeters)
Length:	3 to 17 inches (7.62 to 43.18 centimeters)	
Thickness:	.011 inches (0.28 mm)	Maximum (including backing)
Paper Feed Path:	Bottom	
Printhead Gap Information:	Refer to the Printhead Gap Information, Section 1.6.	

CAUTION:

Use Bottom Feed and/or optional Pull Tractor for card stock and labels.

Transparency

NOTE:

Roller marks may mar the transparency under high temperature / high humidity conditions.

Weight:	12 to 24 lbs. (45 to 90 g/m ²)	
Width:	Microline 590	7.2 to 8.5 inches (18.2 to 21.5 centimeters)
	Microline 591	7.2 to 14.3 inches (18.2 to 36.3 centimeters)
Length:	3 to 17 inches (7.62 to 43.18 centimeters)	
Thickness:	0.14 inches (0.36 millimeters)	
Paper Feed Path:	Top	
Printhead Gap Information:	Refer to the Printhead Gap Information, Section 1.6.	

1.7.02 Length

NOTE:

The recommended length is specific to paper type.

Rear Feed

Minimum 3 inches (7.62 centimeters)

Maximum 17 inches (43.18 centimeters)

Bottom Feed

Minimum 3 inches (7.62 centimeters)

Maximum 17 inches (43.18 centimeters)

Top Feed

Minimum 3 inches (7.62 centimeters)

Maximum 17 inches (43.18 centimeters)

1.7.03 Number of Copies

Original + 4 Interleaf

Original + 4 Carbonless

Original Cut Sheet

1.7.04 Thickness

0.014 inches / 0.36 mm Maximum Thickness, Rear Feed

0.017 inches / 0.44 mm Maximum Thickness, Bottom Feed

1.7.05 Weight

NOTE:

The recommended weight is specific to paper type.

Minimum: 9 lb. (35 g/m²)

Maximum: 24 lb. (90 g/m²)

1.7.06 Width

NOTE:

The recommended width is specific to paper type.

Paper

Microline 590

Minimum: 3.5 inches (8.8 centimeters)

Maximum: 10.5 inches (26.6 centimeters)

Microline 591

Minimum: 3.5 inches (8.8 centimeters)

Maximum: 16.5 inches (41.9 centimeters)

Printing Area

Microline 590 8 inches Maximum

Microline 591 13.6 inches Maximum

1.8 MEMORY SPECIFICATIONS

1.8.01 EEPROM

1 Kbit serial EEPROM (used to store Menu data)

1.8.02 ROM

"Older" Configuration

1 Mbit, Character Generator ROM (located on main control board, 05C)

1 Mbit, Printer Control EPROM (located on main control board, 05D)

"New" Configuration

4 Mbit (located on main control board, 05D)

1.8.03 RAM

Receive Buffer Size is selected through the Menu.

Settings are: 64 K, 32 K, 1 line

1.9 CONSUMABLES

1.9.01 Ribbon

CAUTION:

Using a non-Okidata ribbon may damage the printhead and void any warranties.

Material

Cartridge Fabric

Types

Black Ribbon

Color Ribbon

Magenta

Yellow

Cyan

Black

Life (On average, at 10 characters per inch, Utility Mode)

Black Ribbon 4 million characters

Color Ribbon

Magenta 1.5 million characters

Yellow 0.8 million characters

Cyan 1.5 million characters

Black 1.5 million characters

1.10 OPTIONS

1.10.01 Cut Sheet Feeders

The CSF-5000 is a narrow feeder for the Microline 590.

Single Bin with envelope capability

Paper Width: 7.2" to 8.5" (18.3 cm to 36.3 cm)

Paper Length: 10.1" to 14" (25.6 cm to 35.6 cm)

Capacity: 170 sheets (16 lb.), 100 sheets (20 lb.)

The CSF-5001 is a wide feeder for the Microline 591.

Single Bin with envelope capability

Paper Width: 7.2" to 14.3" (18.3 cm to 36.3 cm)

Paper Length: 10.1" to 14" (25.6 cm to 35.6 cm)

Capacity: 170 sheets (16 lb.), 100 sheets (20 lb.)

1.10.02 Pull Tractor Kit

NOTE:

The Pull Tractor Kit (P/N 70023001) is a narrow feeder for the Microline 590.

The Pull Tractor Kit (P/N 70023201) is a wide feeder for the Microline 591.

Bottom Feed

Rear Feed (For Push/Pull Operation)

Paper Types: Continuous Feed and Labels

1.10.03 Color Ribbon Kit

Includes:

Color mechanism

Color Ribbon

End user installable

1.10.04 Bottom Push Tractor Kit

NOTE:

The Bottom Push Tractor Kit (P/N 70022901) is a narrow feeder for the Microline 590.

The Bottom Push Tractor Kit (P/N 70023101) is a wide feeder for the Microline 591.

Bottom Feed

Paper Type: Continuous Feed

Includes: Stand and Metal Tear Bar

1.10.05 Serial Interface

Super-Speed 19.2K RS-232C

Ready/Busy/X-On/X-Off Protocols

Can be configured through the Menu or OKISmart Utility Program

1.10.06 Roll Paper Stand

Adapts printer for use with roll-type paper (Model 590 only)

Includes: Stand, Support, Cord and DIN plug for connection to printer

1.10.07 Bitstream Facelift 2.0

For Windows 3.0 and 3.1

Includes: 14 scalable fonts

1.10.08 OKISmart Typer Utility

Packaged with printer

Includes: Typewriter Mode, Form Creation Utility and Barcode Utility

1.10.09 OKISmart Panel Utility

Packaged with printer

Includes: Front Panel Control Utility and Drivers for Windows 3.0 & 3.1

NOTE:

The OkiSmart software includes three programs.

- 1. OkiSmart Control*
- 2. OkiSmart Panel Emulator*
- 3. OkiSmart Setup*

Refer to the Printer Handbook for more information.

1.11 RELIABILITY

1.11.01 Mean Time Before Failure (MTBF)

Approximately 6,000 hours: 25% duty cycle / 35% page density

1.11.02 Mean Time To Repair (MTTR)

Approximately 15 minutes to major sub-assembly level

1.11.03 Printer Life

Approximately 16,000 hours of power-on time: 25% duty cycle / 35% page density

1.11.04 Printhead Life

Average 200 million characters in 10 cpi utility mode @ normal 25% duty,
35% page density

1.11.05 Ribbon Life

Black: Approximately 4 million characters

Color:

Black: Approximately 1.5 million characters

Cyan: Approximately 1.5 million characters

Magenta: Approximately 1.5 million characters

Yellow: Approximately 0.8 million characters

1.11.06 Warranty (Limited)

Two years, parts and labor

1.11.07 Service

Authorized Okidata Service Centers

This page was intentionally left blank.

SECTION TWO
PRINCIPLES OF OPERATION

2.1 ELECTRICAL OPERATION

2.1.01 General Information

The printer is made of the following electrical components.

- Main Control Board
- Power Supply Assembly
- Operator Panel
- Space Motor / Line Feed Motor
- Printhead

2.1.02 Main Control Board

The main control board is made up of the microprocessor, peripheral circuits, drive circuits, sensors and interface connectors.

The power to the main control board is supplied by the power supply assembly through a wire harness. The power to other electrical parts, such as the line feed motor, space motor and printhead, is supplied by the power supply assembly through the connectors on the main control board.

Microprocessor (MPU)

Location 04D: 67X640

16 bit MPU, using CMOS technology.

The MPU contains a 20 bit address bus, a 16 bit data bus.

The MPU can access 1 Mbyte of program memory space and 1 Mbyte of data memory space.

The microprocessor controls the entire printer by executing the control program through the LSI and the driver circuit.

Block Diagram

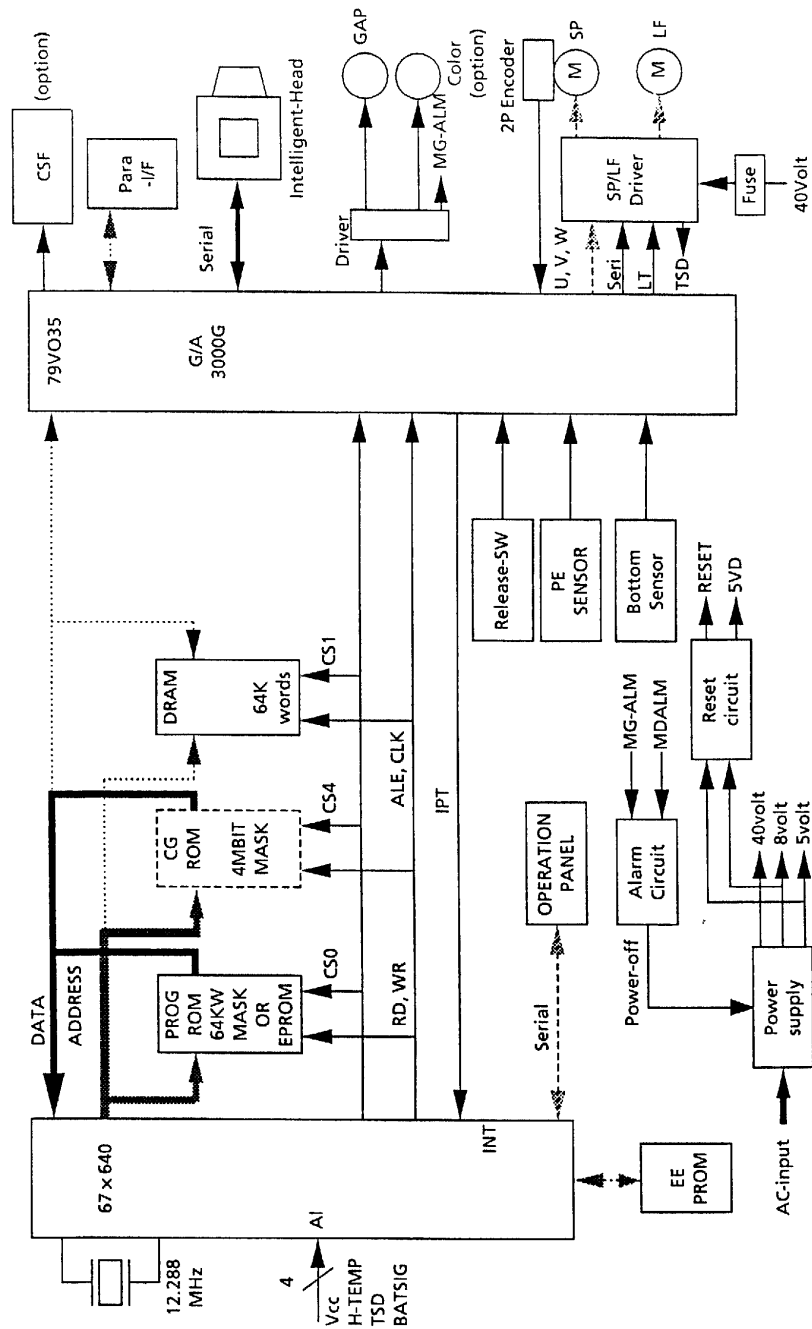

ML590/591 BLOCK DIAGRAM

Program ROM

Location 05D: 27C1024

This 64k x 16 bit (Mbit) EPROM contains the control program for the printer. The MPU executes the instructions contained in this program.

The Program ROM is assigned to the program memory area of the MPU and instructions are fetched by the PSEN signal of the MPU.

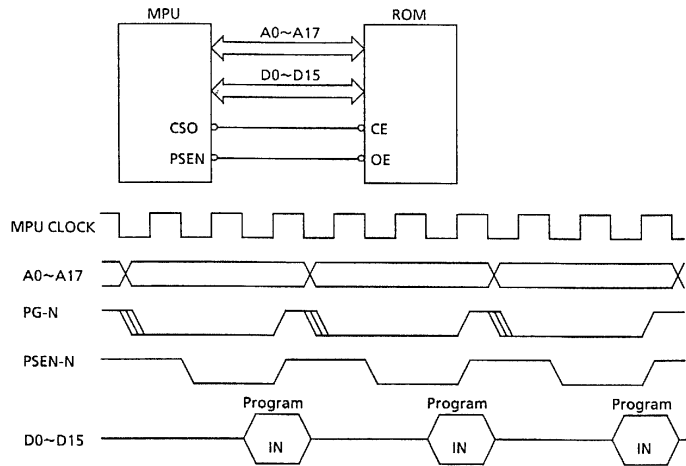

2-02.tif

RAM

Location 05E: 511664Z.

The RAM is CMOS dynamic RAM with 65,536 words x 16-bit configuration, and is used as a receive buffer, print buffer and work buffer.

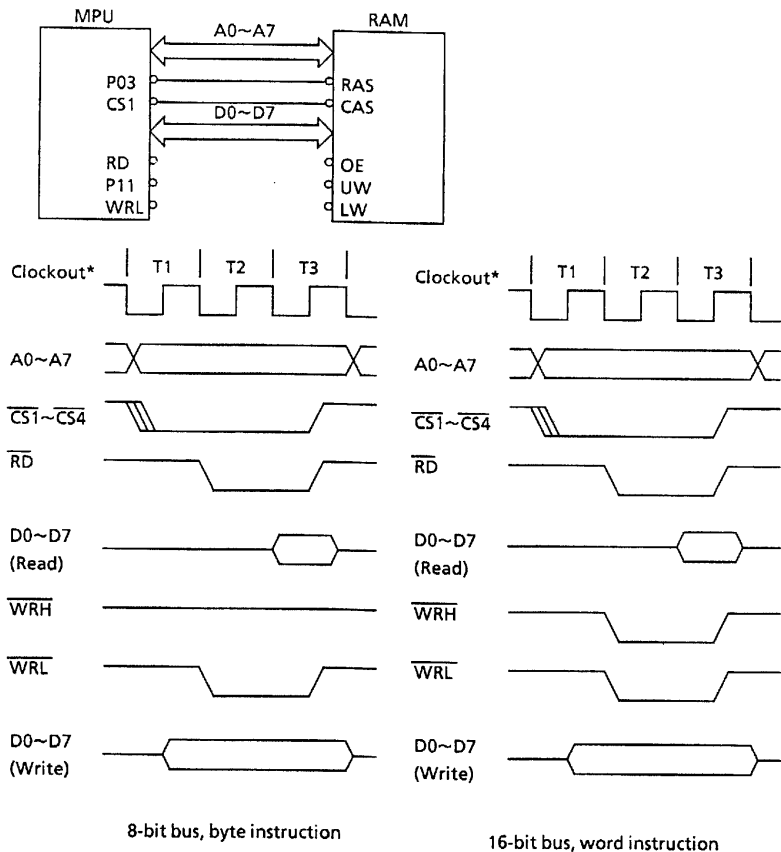

*Clockout is provided when the original excitation is selected.

2-03.tif

Character Generator ROM (CG ROM)

Location 05C: 27C4096.

This 256k x 16 bits (4 Mbit) masked EPROM contains the character data for the various fonts.

The CG ROM is assigned to the program memory area of the MPU. The data is accessed by the PSEN signal of the MPU.

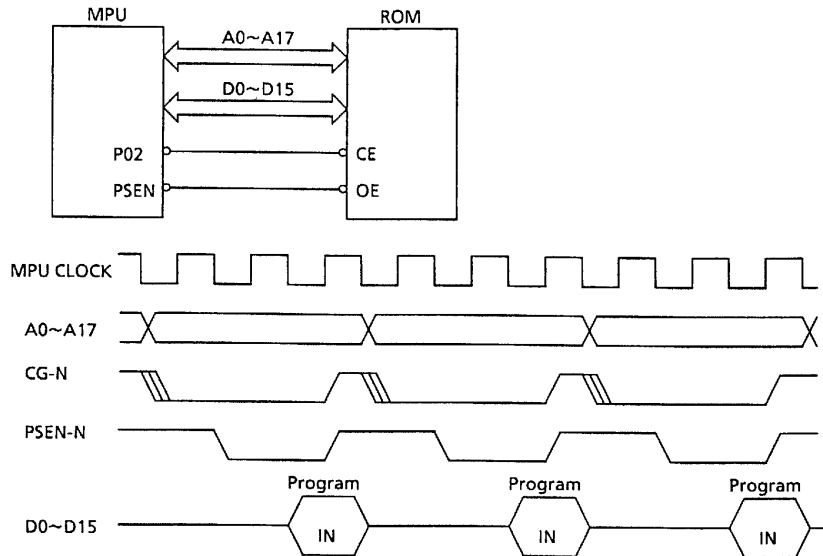

2-04.tif

Electrically Erasable Programmable ROM (EEPROM)

Location 03C: 93CS46.

The EEPROM is a CMOS serial I/O type memory which is capable of electrically erasing and writing 1,024 bits.

The EEPROM contains the menu data and the head drive time correction data.

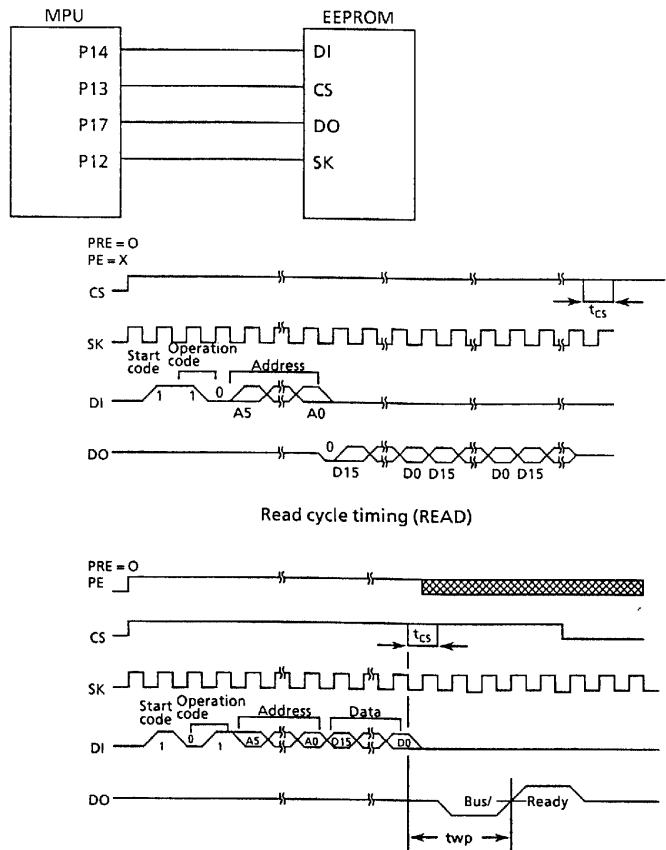

2-05.tif

LSI

Location 02D: MSM(79V035).

Detects the output of the two-phase sensor on the DC space motor to control the motor drive phase.

Transmits and receives serial data to and from the printhead based on the dot timing (which is derived from the space motor speed).

Controls the external interface. The LSI is connected to the MPU.

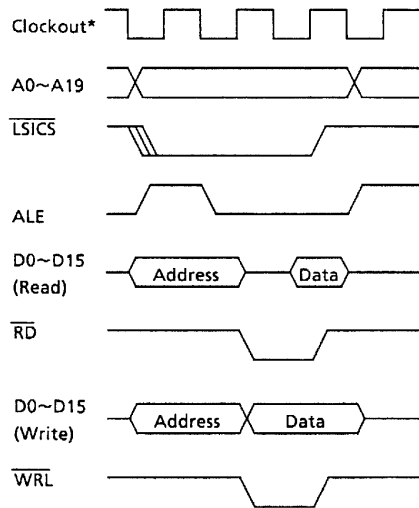
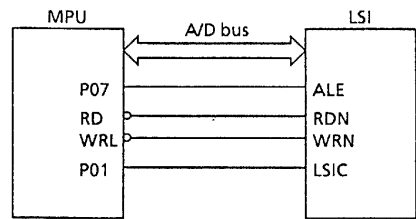

* Clockout is provided when the original excitation is selected.

2-06.tif

2.1.03 Initialization

This printer is initialized when the printer is powered on or when the I-PRIME-N signal is input from the host via the parallel interface.

Printer Initialization occurs as listed below.

The RST-N signal is output from the Reset circuit to reset the MPU and LSIs.

The program is executed and the LSIs are reset by the MPU via IORST-N.

NOTE:

A Reset operation initiated by I-PRIME does not reset the MPU.

The program sets the LSI (02D) mode, checks the memory (ROM/RAM), then executes carriage homing and determines the phase of the line feed motor.

Finally, the program establishes the interface signals (P-I/F: ACK-P signal sending, and S-I/F: BUSY-N signal off) and lights the SELECT lamp to indicate that the printer is in the ON-LINE state.

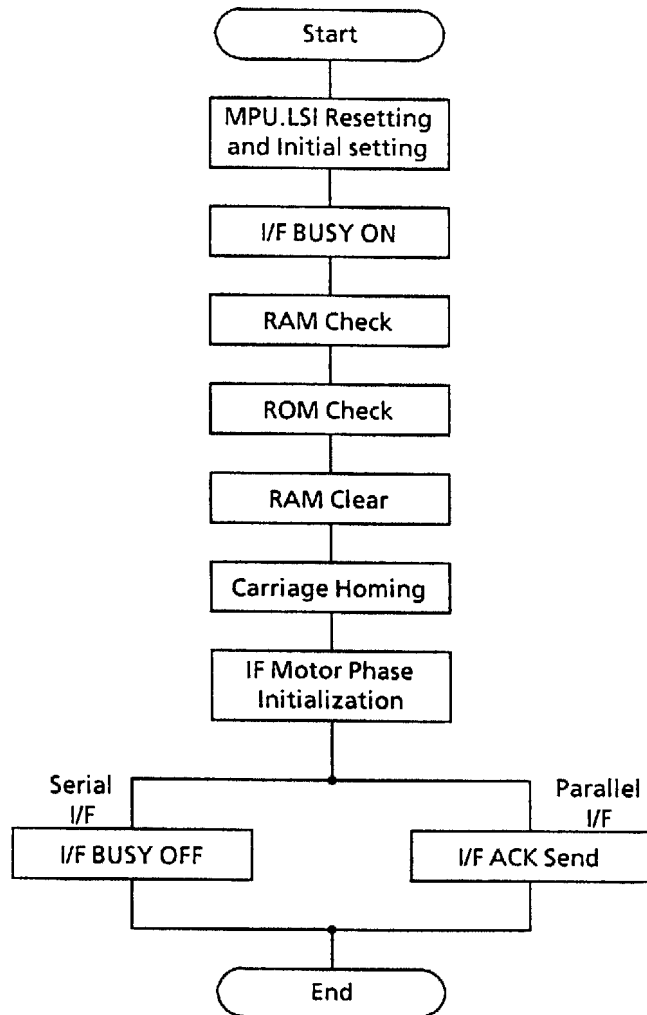

2-07.tif

2.1.04 Parallel Interface Control

The parallel data input from the host to the interface LSI is latched to the internal register by the falling edge of the STROBE-N signal.

The LSI sets the BUSY-N signal to inform the host that the data is being processed. The LSI also outputs the RXD-N signal to inform the MPU of data reception. The data is read upon receiving the RD-N signal from the MPU.

When the data processing is complete, the BUSY-N signal is disabled and the ACK-N signal is sent to request the next data. When the buffer is full and reception is not desired, the BUSY signal is sent to request data transmission be stopped.

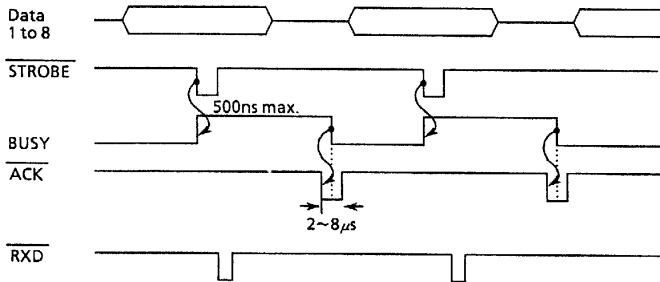
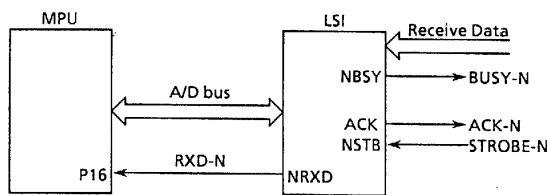

NOTE:

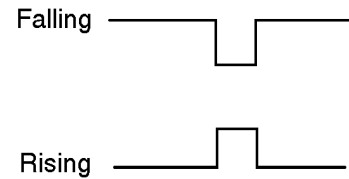

2-1-03.pcx

2-08.tif

2.1.05 Print Control

The print data is transmitted as serial data from the LSI to the control circuit and the driver contained in the printhead.

After the data is printed, the sensor analog circuit controlling each pin returns the pin stroke data to the MPU. The MPU will make an automatic head gap adjustment. This feedback system sets the optimum drive time for each pin in order to maintain high print quality.

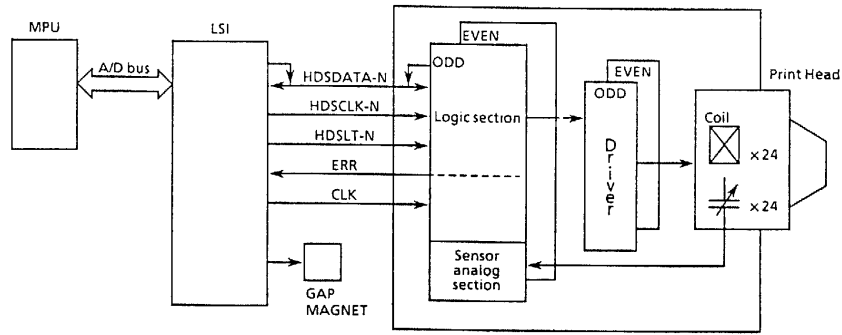

2-09.tif

LSI/Printhead Interface

The connection between the LSI and the printhead is made with the bi-directional serial data bus. The LSI transmits the print data as serial data to the logic circuit of the printhead. The printhead returns serial data from the printhead sensor analog circuit to the LSI. This information is used to determine the optimum drive time for the next print request.

The logic circuit of the printhead signals the LSI if a parity error is detected in the print data.

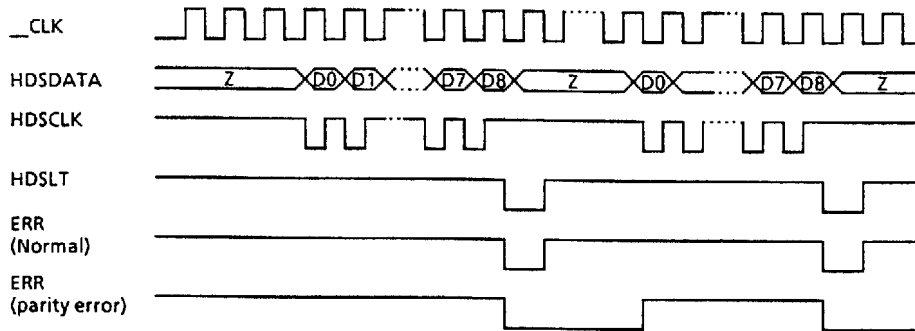

2-10.tif

Gap Adjust Control

The Gap Adjust LSI receives stroke length information for all of the printhead pins from the sensor analog circuit. The Gap Adjust LSI then sets the optimum printhead gap for the printing medium.

NOTE:

Refer to Section 2.2.03 for a description of the mechanical process.

All values in the chart are in millimeters

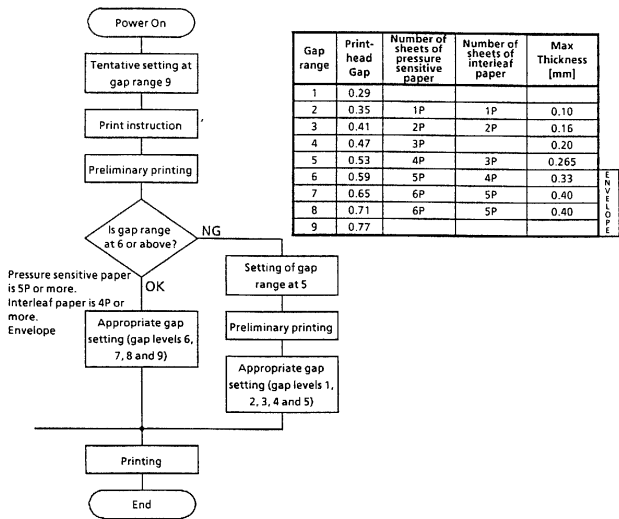

2-11.pcx

Print Compensation Control

The printhead compensates for the shape of the platen as shown below.

NOTE:

Refer to Section 2.1.08 - Head Drive Time

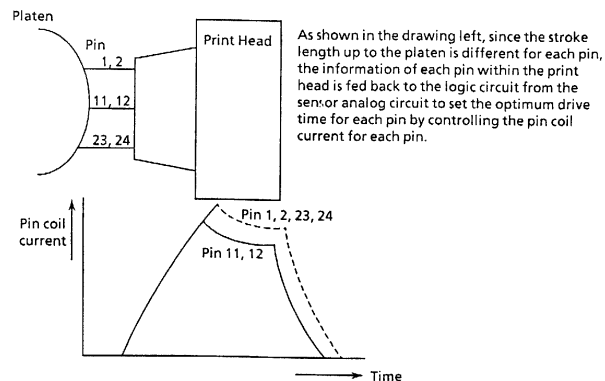

2-12.pcx

2.1.06 Space and Line Feed (SP/LF) Motor Control

The LSI (Location 02D: MSM79V035) generates the space motor and the line feed motor control signals according to commands received from the MPU. These signals are sent to the SP/LF motor driver.

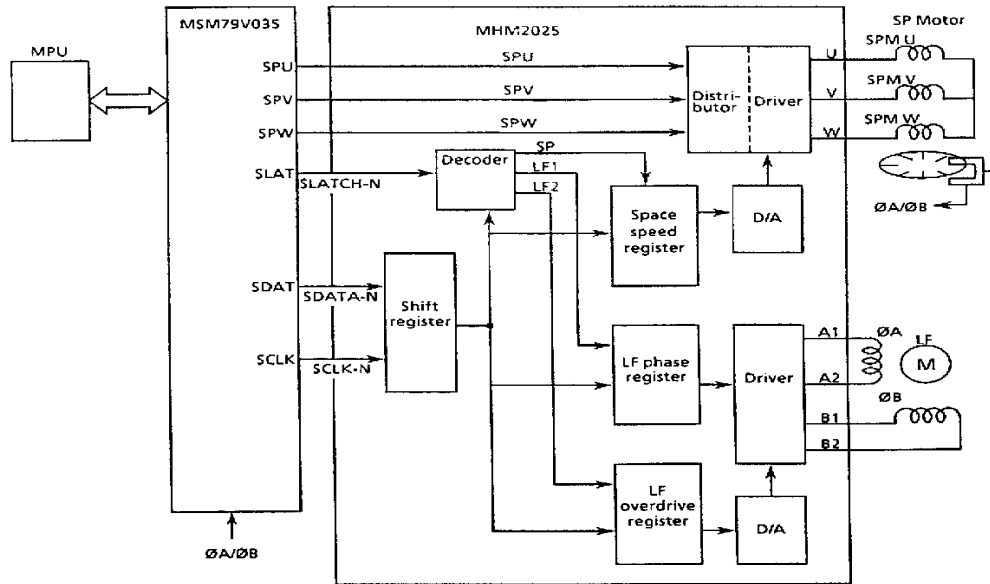

Transmission of SP/LF Motor Control Data

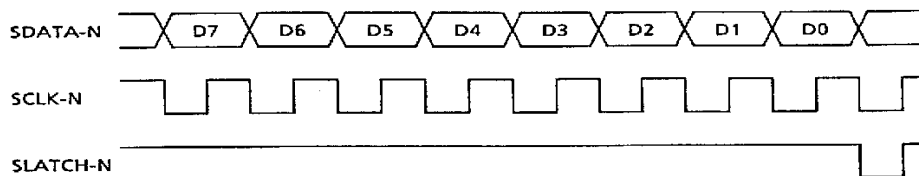

2-13.pcx

Line Feed Motor Control

The SP/LF motor driver (Location 5A: MHM2025) drives the line feed motor in two-phase bipolar, based on the phase changeover data output from the LSI.

The serial data from the LSI (02D:MSM79V035) is processed by a register contained in the SP/LF motor driver to measure the overdrive time and to change the phase.

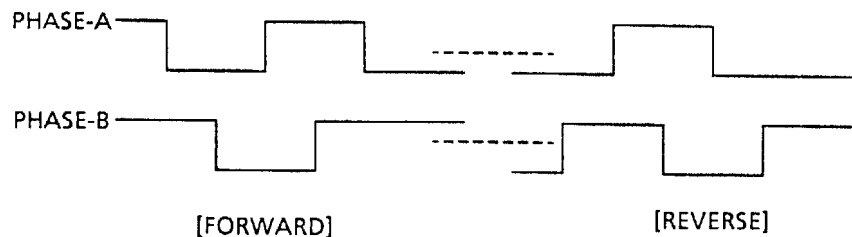

2-15.pcx

Space Motor Control

The SP/LF motor driver (Location 5A: MHM2025) drives the three-phase brushless motor. Motor movement is based on the phase signal (SPU,SPV and SPW) and the speed instruction data from the LSI. The MPU can identify the current speed of the space motor by measuring the pulse width of the output (Phase A, Phase B) of the encoder disk sensor.

After comparing the target speed for each print mode with the actual speed, the motor is accelerated or decelerated to maintain the desired speed for each print mode.

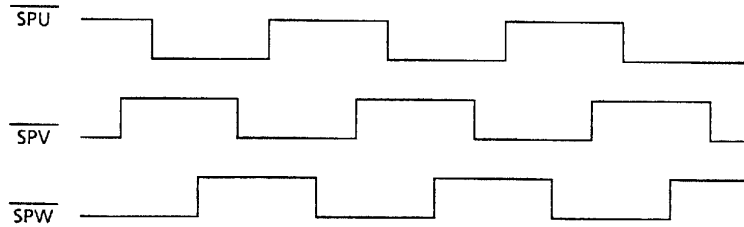

SP truth table

HALL AMP INPUT			OUTPUT		
SPU	SPV	SPW	U	V	W
H	H	L	OPEN	L	H
H	L	L	L	OPEN	H
H	L	H	L	H	OPEN
L	L	H	OPEN	H	L
L	H	H	H	OPEN	L
L	H	L	H	L	OPEN

2-14.pcx

Encoder Disk

As the space motor operates, the encoder disk spins. When the encoder disk interrupts the photo sensors, the signals Phase A and Phase B are generated. The LSI (Location 02D: MSM79V035) divides these edge pulse signals (the frequency division is based on the selected print pitch) to generate the signal IPT. The IPT signal provides dot-on timing and carriage position detection timing.

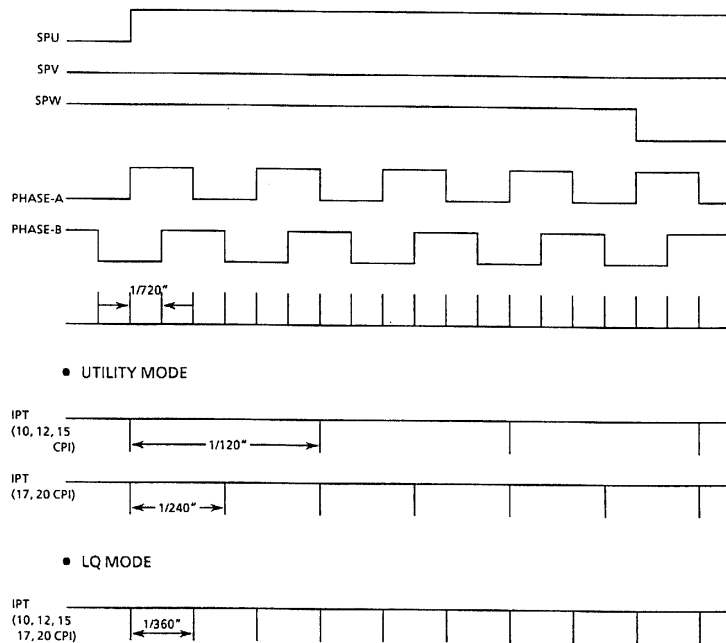

2-16.pcx

2.1.07 Operation Panel

The Serial I/O Port (Ports 20 - 23) of the MPU reads the operation panel switch data from the operation panel control LSI (Location IC1: BUS148S). The Serial I/O Port also outputs LED data to the operation panel control LSI.

A two byte (15 bits +1 parity bit (even parity)) command (OPTXD) is transmitted from the MPU to the operation panel LSI in synchronization with the OPCLK signal. Once the LSI decodes the command, the command must pass a command code check and have no parity errors. Then, the specified I/O control will return the two byte command response to the MPU.

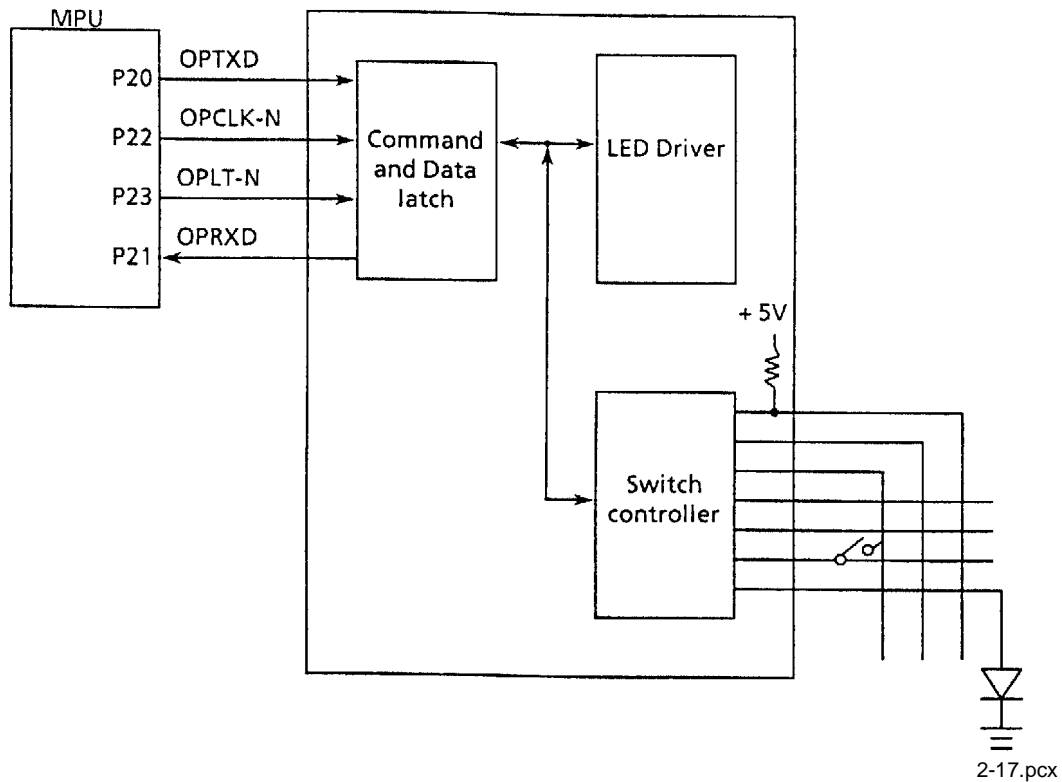

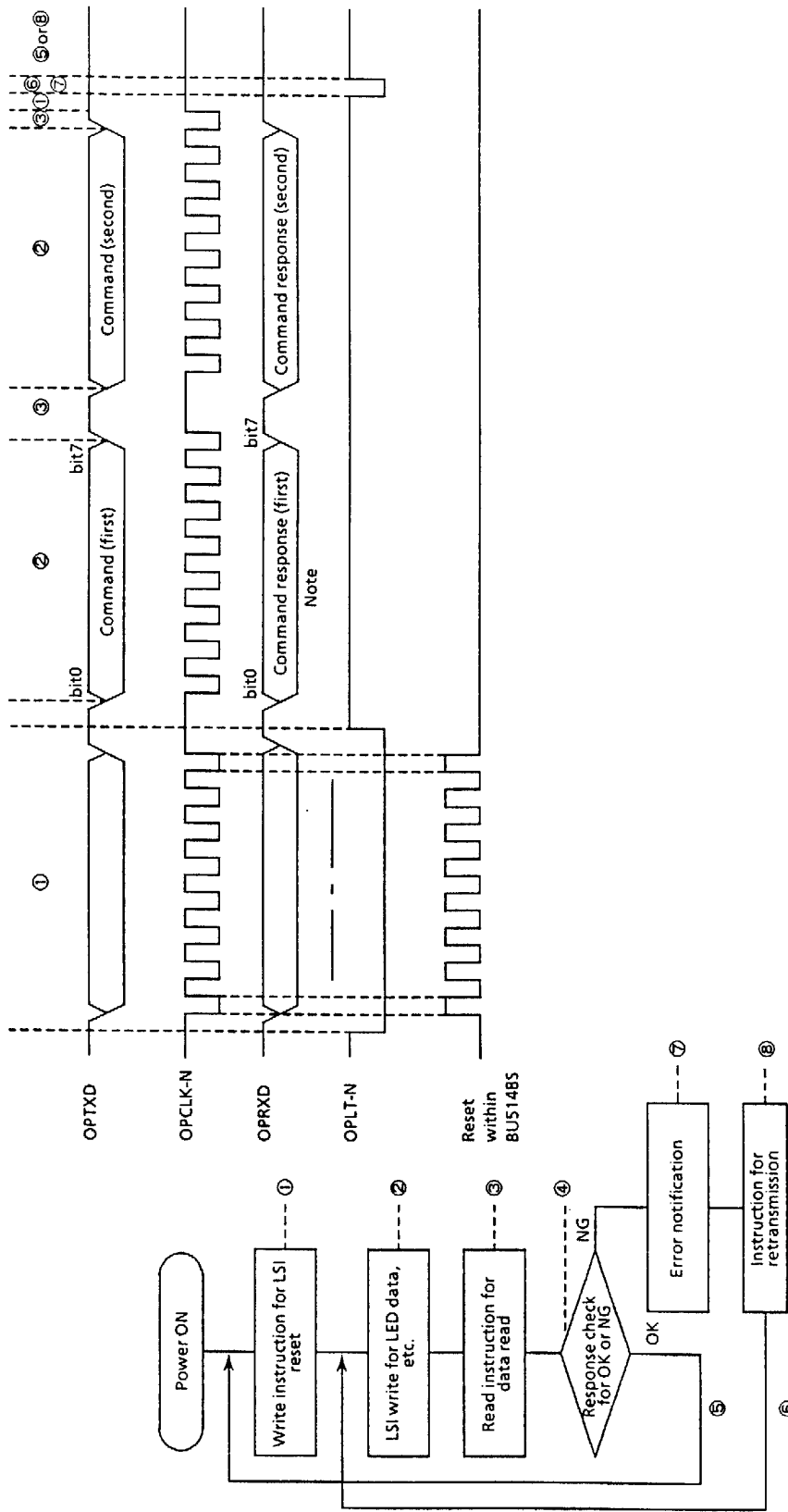

Note : From the illustration above, you can see that the command and the command response are output at the same time. This is because the bit 0 to bit 3 of OPRXD are fixed so that the response can be returned before decoding the command.

2.1.08 Alarm Circuit

Driver Circuit Alarm Processing

The printhead driver output, the head gap magnet output and the color ribbon magnet drive signal are monitored at R670 and C15, and the POWER OFF-P signal is output by the comparator (Location 01A: IC2901) when driven for more than the specified time. This signal becomes the ALM signal. The ALM signal is sent to the power supply board and causes the DC voltages to be turned off.

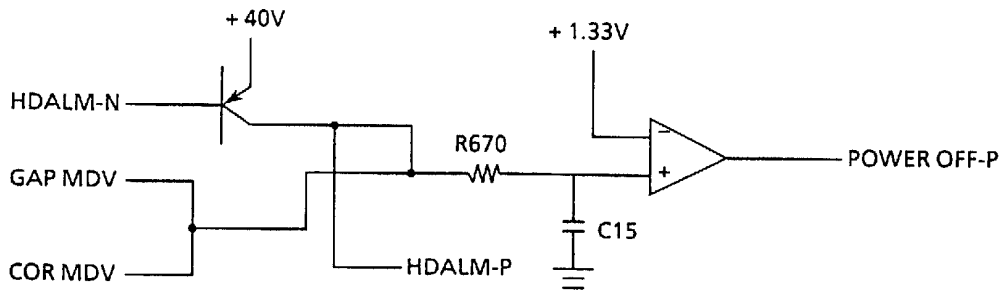

Low Motor Drive Voltage Alarm

+40V is converted into the POWLEV signal (0 vdc to +5 vdc) by the voltage divider network of R533 and R537, then input to the A/D port of the MPU. The value of this voltage is used to control the drive time and the print speed (pass number) of the head.

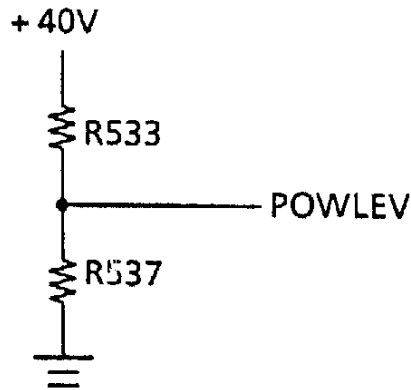

2-20.pcx

2-21.pcx

Head Drive Time

The head drive time is modified to compensate for the amount of the voltage drop of the POWLEV signal. By monitoring the voltage drop every 500 microseconds, the MPU is able to control and maintain the impact necessary for each printhead pin.

Print Speed

Actual Voltage (+40 vdc)	Passes Required	Relative Print Speed
+34 vdc or greater	1	100%
+32 vdc to +34 vdc	1	Approximately 85%
+30 vdc to +32 vdc	1	Approximately 50%
+30 vdc or less	2	Less than 50%

Head Overheat Alarm Processing

Two thermistors are used to monitor the printhead temperature. One is contained in the printhead and the other in the printhead driver. The voltage of the TSD signal is monitored at the MPU A/D port to control the pass number and print method (unidirectional / bi-directional) at each of seven levels. If the printhead temperature exceeds 110 degrees Celsius, the printer will switch to unidirectional print. If the temperature exceeds 115 degrees Celsius, printing will stop. Once the printhead cools, printing will resume.

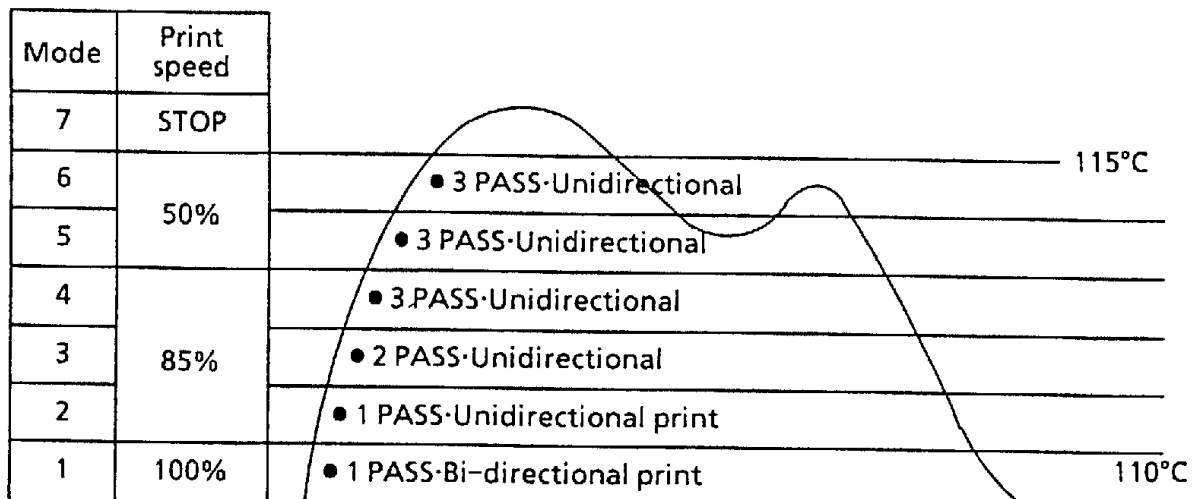

2-22.pcx

2.1.09 Power Supply Circuit

The switching type power supply circuit supplies the +5 vdc, +/-8 vdc, +12 vdc and +40 vdc.

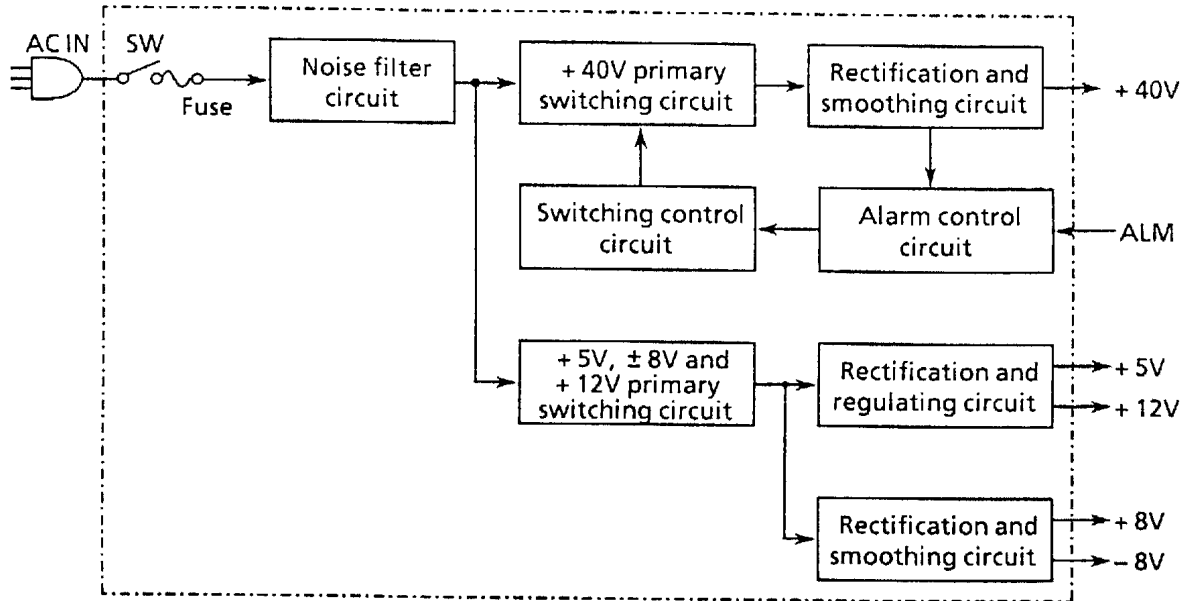

2-23.pcx

Table of Output Voltages

Voltage / Signal	Purpose
+5 vdc	IC logic levels, LED drive voltages
+8 vdc	Serial interface line voltage, comparator IC
-8 vdc	Serial interface line voltage
+12 vdc	Printhead analog circuit
+40 vdc	Printhead, space motor and line feed motor drive voltage
ALM	Output from the main control board upon detection of an abnormality in the printhead, head gap or color ribbon drive circuits. This signal will cause all DC voltages to be turned off.

2.2 MECHANICAL OPERATION

2.2.01 Printhead Mechanism

The printhead is a spring charged 24-pin printhead. It is attached to the carriage, which moves parallel to the platen. Electrically, the printhead is controlled by the main control board via the carriage cable and the space motor.

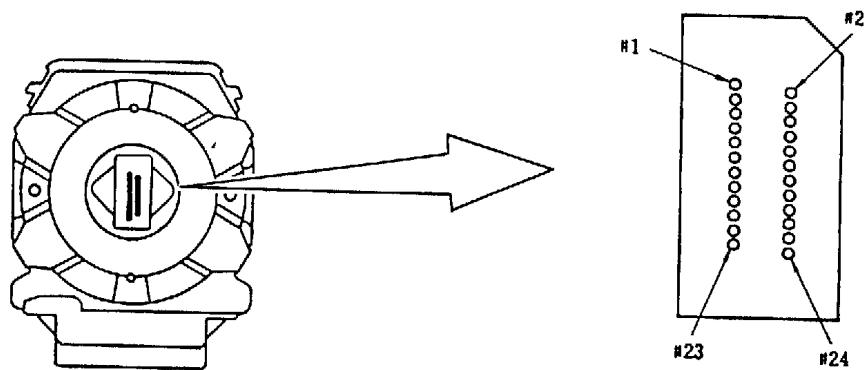

Arrangement of the head pins
View from the tip of the printhead

2-24.tif

The printhead is composed of the following parts.

Wire Guide

Spring Assembly (Wire, Armature, Spring, Yoke, Spacer)

Magnet Assembly (Magnet, Core, Coil, Yoke)

Printed Circuit Board (Logic Control, Print Driver, Analog Sensor Control and Thermistor)

Cooling Fin

Printhead Gap Information

Three items factor into printhead gap information.

1. Printhead Gap Adjustment

This is a SERVICE ADJUSTMENT made by a technician.

It is covered in Section 3.3 of this Service Handbook.

The Adjustment measures 0.014, +/- 0.001 inches (0.35, +/- 0.03 mm).

2. Printhead Gap Adjust

This is a MENU ITEM in the SET-UP Group.

It fine tunes the automatic setting of the printhead gap.

The settings are 0, 1, and -1.

0 is the factory default.

Use 1 to *darken* print (if output is *consistently light*).

Use -1 to *lighten* print (if output is *consistently dark*).

3. Gap Control

This is a MENU ITEM in *each* [Paper Feed] Group.

The Groups are REAR FEED, BOTTOM FEED, and TOP FEED.

Gap Control determines how the printhead gap is set.

The settings are listed below.

Auto Gap, Semi Auto Gap, 1, 2, 3, 4, 5, 6, 7, 8, 9

An explanation of each setting follows.

Auto Gap

This is the factory default.

Automatically determines paper thickness of the first page.

During single-sheet feed, each page's thickness is checked *while* a job is printing.

Semi Auto Gap

Similar to Auto Gap.

Automatically determines paper thickness of the first page.

During single-sheet feed, each page's thickness IS NOT checked "while" a job is printing.

1, 2, 3, 4, 5, 6, 7, 8, 9

Used when the same paper is used ALL of the time.

Bypasses the automatic head gap adjustment.

1 is the narrowest gap setting.

9 is the widest gap setting.

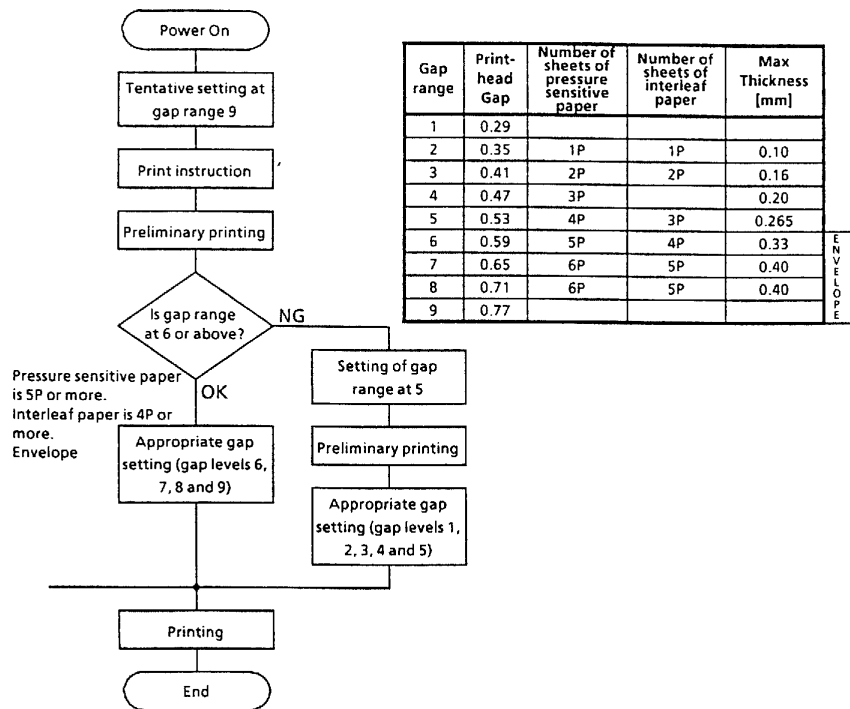

2-2-01d.tif

Interconnect Diagram: Control Board to Printhead

NOTE:

The printhead coil resistance values ARE NOT LISTED.

The individual printwire control lines CANNOT be accessed on this printhead.

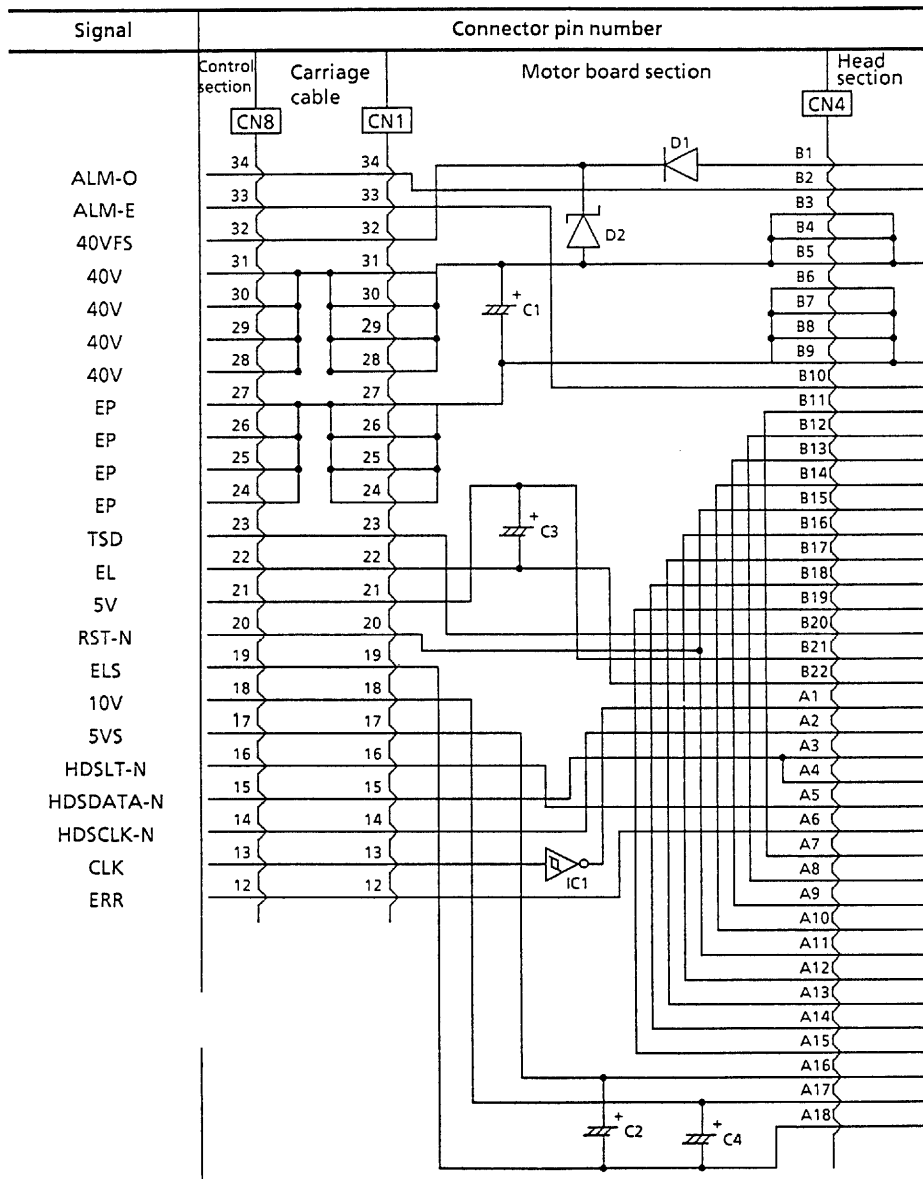

2-2-01A.pcx

Line Feed Motor Resistance

The resistance of each coil should be approximately 13 ohms.

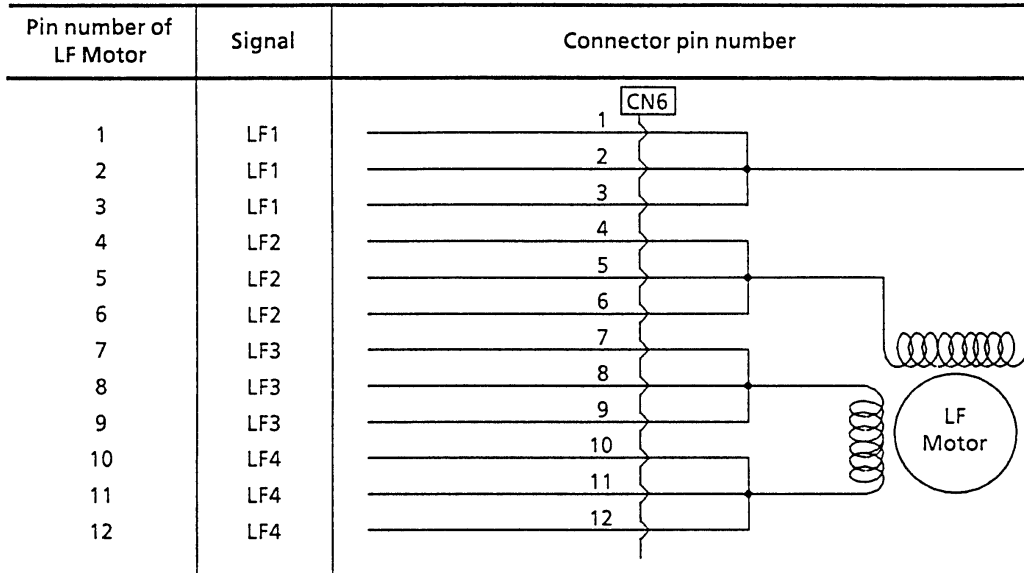

2-2-01B.pcx

Space Motor Resistance

The resistance of each coil should be approximately 5 ohms.

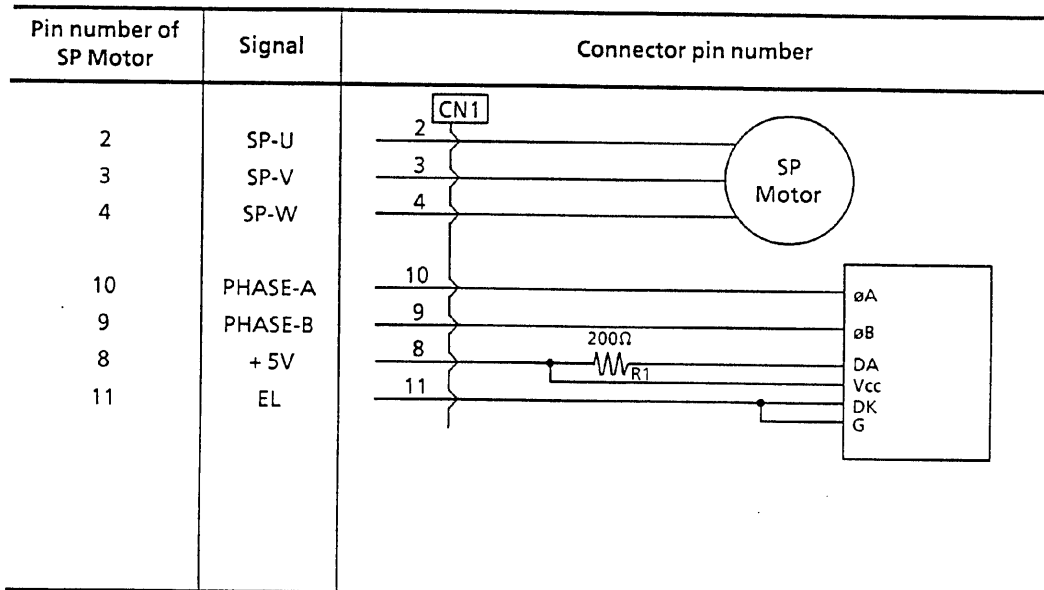

2-2-01C.pcx

Printhead Operation

When the printhead is idle, the armature is attracted to the permanent magnet. The print wires, which are attached to each armature, are then concealed inside the wire guide.

When a signal to print a character is received, current flows through a coil. The magnetic field generated by the coil opposes the magnetic field between the armature and the permanent magnet. The armature is then driven in the direction of the platen by the force of the armature spring. The print wire, which is attached to the armature, protrudes from the tip of the wire guide, strikes the paper through the ribbon and prints a dot on the paper.

As the armature gets closer to the electrode of the analog sensor, the capacitance between them increases and a small amount of current flows. This current is amplified and sent to the logic control LSI to indicate armature activity. In order to attain optimum drive time, this information is transferred to the MPU. The MPU continually modifies the head gap to maintain the optimum drive time condition.

The analog sensor element monitors all of the pins. The difference in pin stroke due to the curvature of the platen is compensated for at the logic control section of the printhead and is not transferred to the MPU.

After the character has been printed, the permanent magnet attracts the armature and the print wires are retracted into the wire guide.

Two thermistors are used to monitor the printhead temperature.

A thermistor in the printhead prevents over-heating of the coil during periods of continuous bi-directional printing. If the printhead temperature exceeds 110 degrees Celsius, the printer will switch to unidirectional print. If the temperature exceeds 115 degrees Celsius, printing will stop. Once the printhead cools, printing will resume. When the temperature of the coil exceeds the pre-determined limits, the control circuit detects the thermistor signal (TSD).

A thermistor in the printhead driver monitors the temperature of the driver. If the temperature of the driver exceeds the pre-determined limits (110 degrees Celsius - unidirectional printing / 115 degrees Celsius - printing stops) the control circuit detects the thermistor signal (TSD). The voltage of the TSD signal is monitored at the MPU A/D port to control the pass number and print method (unidirectional / bi-directional) at each of seven levels.

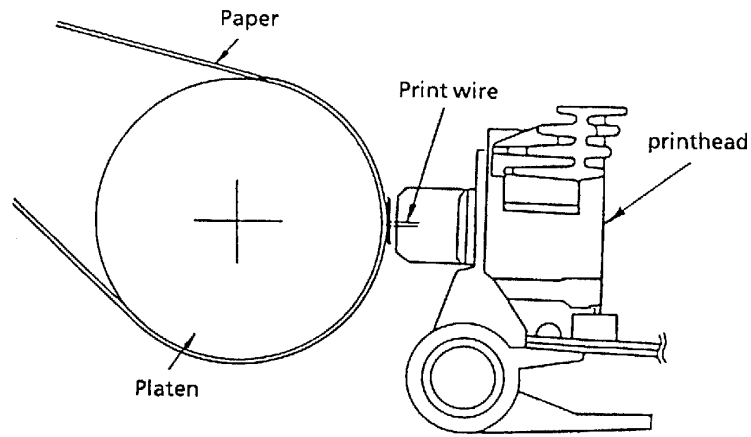

(1) When printing

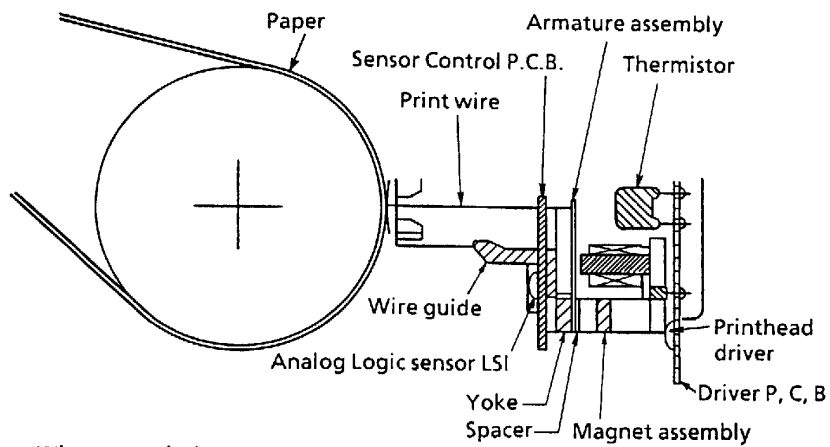

(2) When not printing

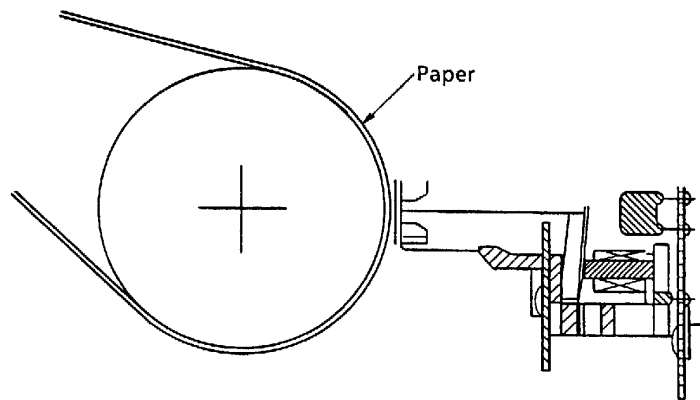

2-25.tif

2.2.02 Spacing Mechanism

The spacing mechanism consists of a carriage shaft (mounted parallel to the platen), and a carriage frame which moves along the shaft. The carriage frame is driven by a DC servo motor mounted on the carriage frame. Items included in the spacing mechanism are listed below.

Space Motor Assembly

DC Servo Motor

Motor gear

Sensor

Encoder Disk

Carriage Frame

Carriage Shaft

Space Rack

Spacing Operation

The carriage frame, which contains the printhead and space motor, moves along the carriage shaft parallel to the platen. When the space motor rotates, the driving force is transmitted to the motor gear. As the motor gear rotates, the carriage moves along the platen. For every revolution of the DC servo motor, the carriage frame moves 0.8 inch (20.32 mm).

As the DC servo motor rotates, a slotted disk (called the encoder disk), passes between a light source and two photosensors. The position of the carriage frame can be determined by counting the pulses generated by the photosensors.

In the same way, the rotation of the space motor can be recognized and controlled by measuring the phase relationship and the pulse width of the signals generated by the photosensors.

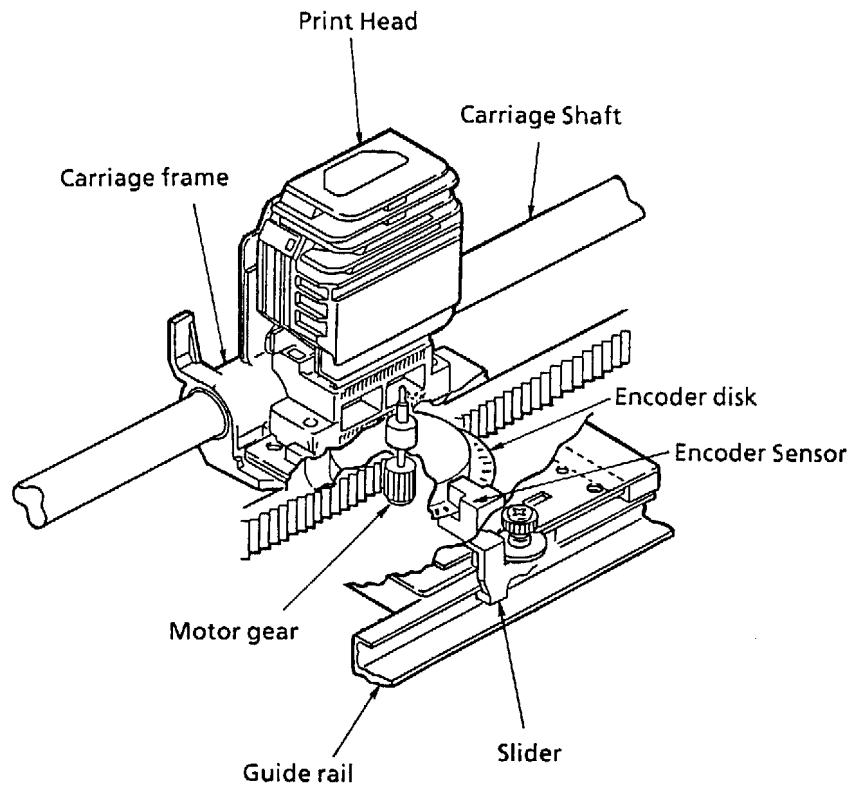

2-26.tif

2.2.03 Head Gap Mechanism

The head gap is automatically set for the thickness of the medium loaded in the printer. In the case of envelopes, where the medium thickness varies as the printhead moves along the platen, the head gap changes to compensate for the differences in thickness.

Head Gap Setting Operation

Once printing starts, the space motor rotates the ribbon gear, causing idle gear C to turn the change gear.

When the MPU requests a change in the head gap setting, the GAP-P signal causes the armature (which is holding the change gear) to be attracted to the pranger magnet. The gap reset spring can now push the change gear so it contacts the gap change gear.

The rotation of the gap change gear causes idle gear D to turn the adjust gear. The adjust gear turns the adjusting screw, resulting in a new head gap setting.

NOTE:

As the adjusting screw turns counter-clockwise, the gap narrows.

As the adjusting screw turns clockwise, the gap widens.

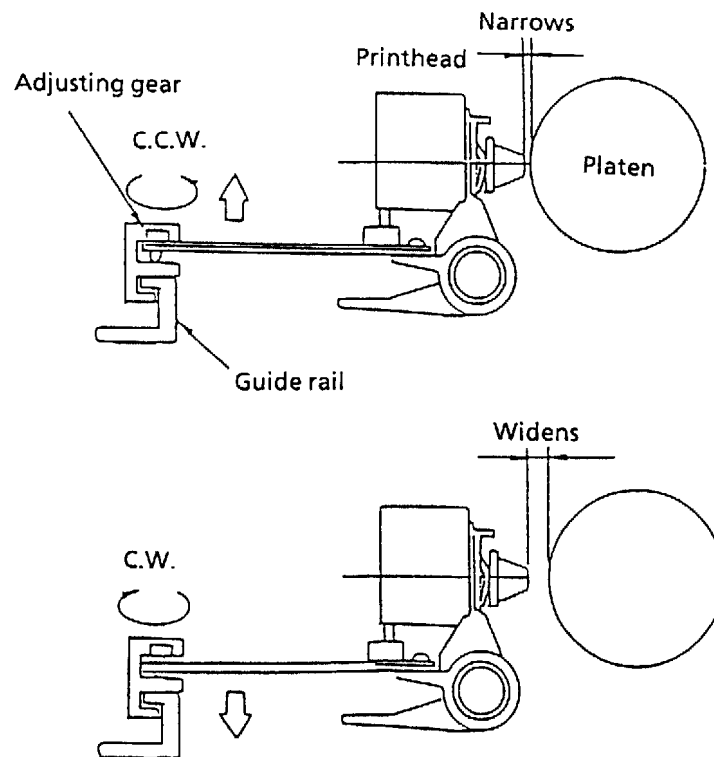

2-28.tif

There is a cam at each setting of the gap change gear. When the change gear is at the top of the cam, the change gear disengages from the gap change gear. At this time, the armature resets, changing the head gap by one setting.

The head gap is modified in .06 mm units for each range setting.

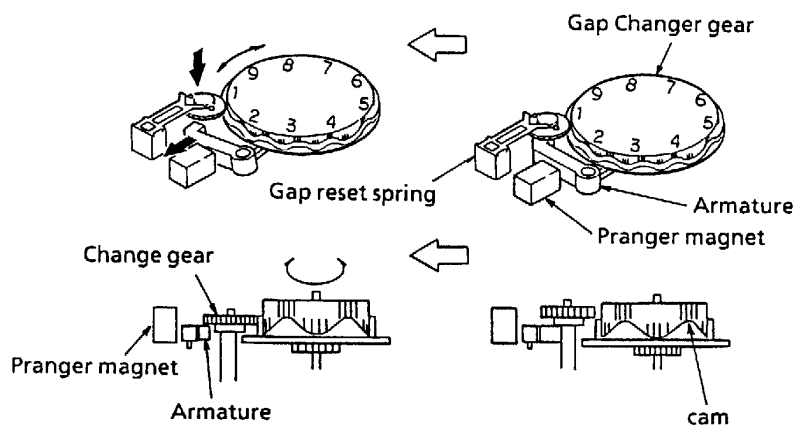
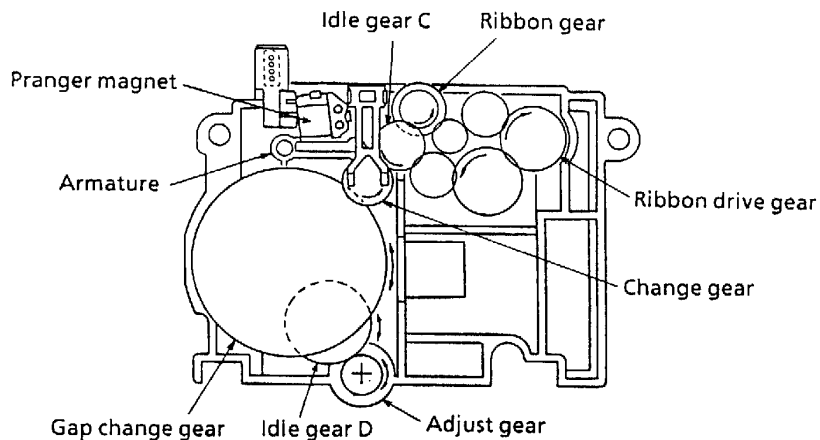

2-27.tif

2.2.04 Ribbon Drive Mechanism

Black Ribbon Drive Operation

The ribbon drive mechanism feeds the ribbon in synchronization with the spacing operation. The force required to drive the ribbon is obtained from the space motor.

The ribbon drive mechanism is composed of the following items.

- Ribbon drive gear assembly

- Ribbon gear (located on the space motor assembly)

- Ribbon cartridge

A continuous loop ribbon with unidirectional feed is used. Ink is supplied from an ink tank, which is built into the ribbon cartridge.

When the space motor turns, the ribbon gear on the spacing motor shaft rotates. The rotation is transmitted via a combination of gears, from the ribbon drive gear assembly to the drive gear in the ribbon cartridge.

Although the space motor moves in both the forward and reverse directions during bi-directional printing, the gears in the ribbon drive assembly maintain unidirectional ribbon feed by switching the rotation direction of the gears.

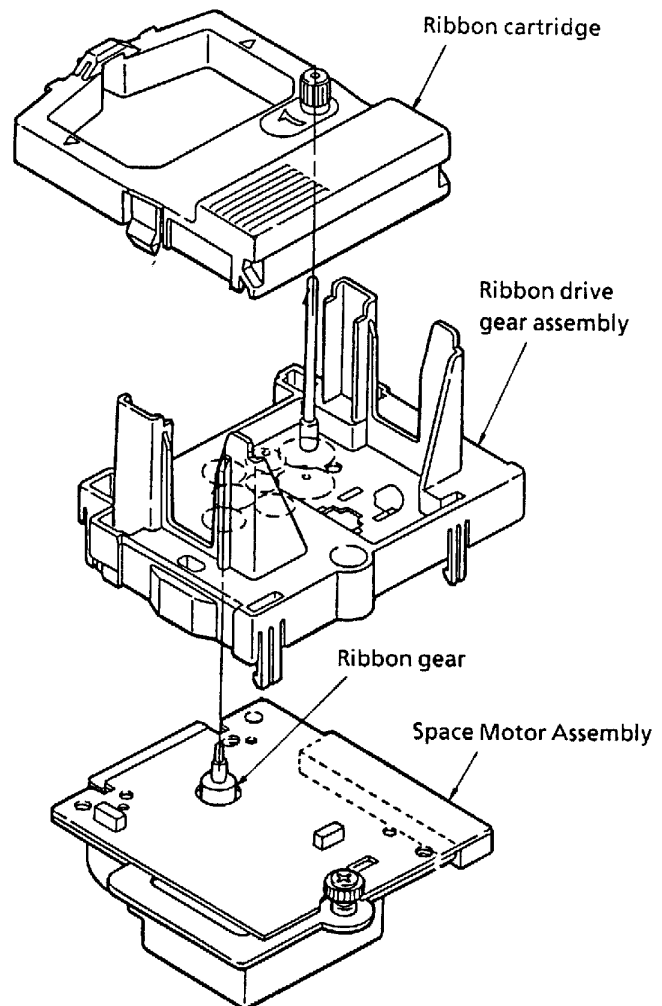

2-29.tif

Color Ribbon Shift Mechanism

Items of the color ribbon unit option are listed below.

- Color shift unit
- Color ribbon (4 colors)

Four colors can be selected by sliding the color ribbon holder up or down. Here is a description of how the ribbon holder is shifted.

As the space motor moves, idle gear C on the ribbon drive unit rotates. Idle gear C rotates the color idle gear, located in the color shift unit.

When the color-P signal from the main control board activates the pranger magnet, the magnet attracts the armature. This causes the reset spring to force the change gear downward. The color idle gear rotates the change gear, which turns the color change gear. The color change gear turns the color cam shaft. The rotation of the color cam shaft moves the color ribbon holder up/down to select the desired ribbon color.

There is a cam at each setting of the color change gear. When the change gear is at the top of the cam, the change gear disengages from the color change gear. At this time, the armature resets, changing the color band selection by one setting.

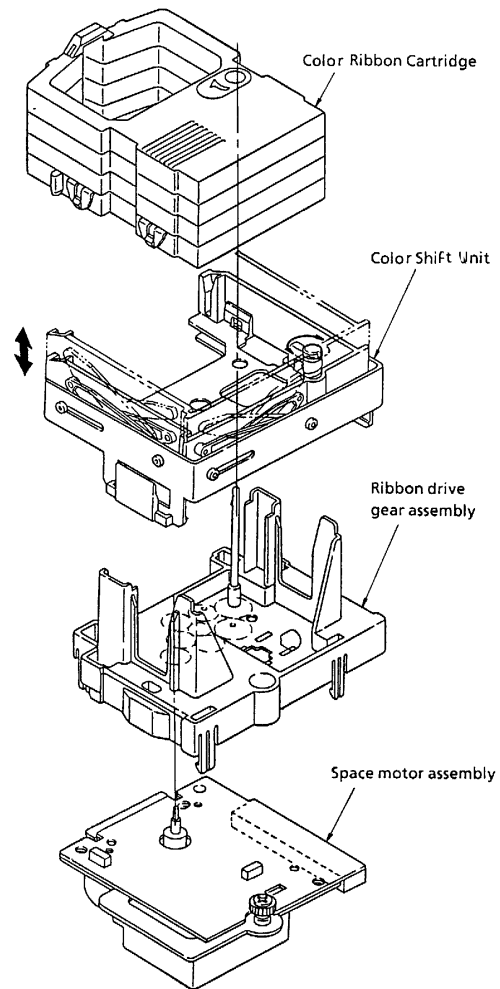

2-30.tif

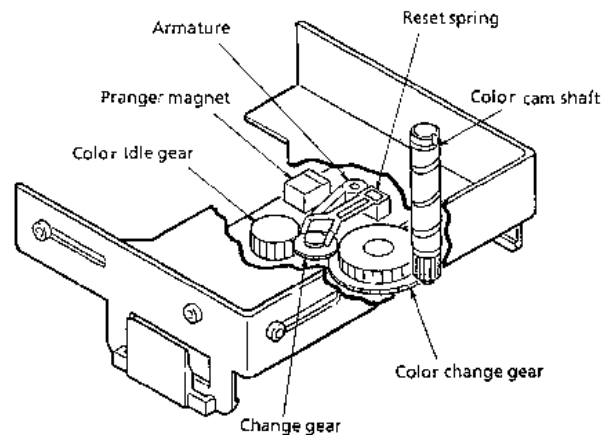

2-31.tif

2.2.05 Line Feed Mechanism

The line feed operation is accomplished by activating the line feed motor which turns the platen. The rotation of the platen is used to feed paper from the selected paper path.

Components of the paper feed mechanism are listed below.

- Line Feed Motor (pulse motor) with Gears
- Line Feed Idler Gear
- Platen
- Rear Tractor Feed Unit
- Pressure Roller

Change Lever (Paper Path Selection Lever)

The change lever is used to select one of three different paper paths; top, rear or bottom.

Paper Clamp Mechanism

Moving the Change Lever between the Bottom, Top and Rear positions, changes the positions of the Front Release Gear Arm and the Release Cam.

The movement of the Front Release Gear Arm changes the position of the Front Release Gear Shaft. This causes the Front Pressure Roller to open or close.

The movement of the Release Cam causes the Rear Pressure Roller to open or close.

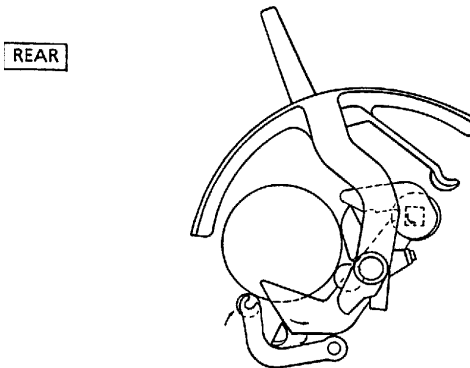
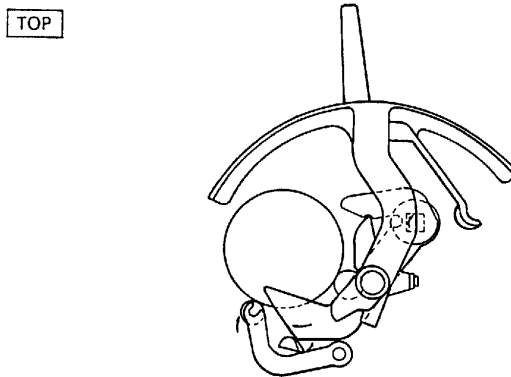
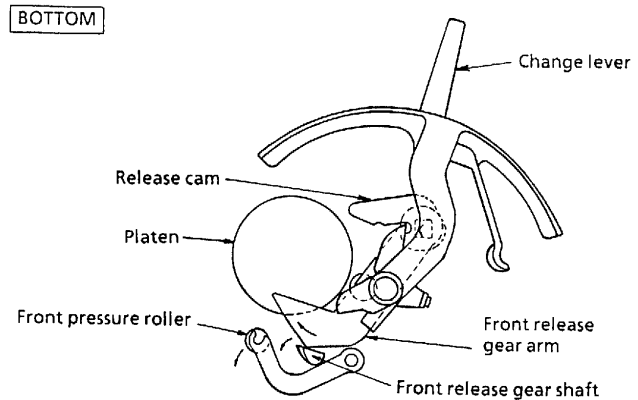

2-38.tif

Position of Change Lever	Status of Front Pressure Roller	Tension of Front Pressure Roller	Status of Rear Pressure Roller	Tension of Rear Pressure Roller
Bottom	OPEN	N/A	OPEN	N/A
Top	CLOSED	250 g	CLOSED	700 g
Rear	CLOSED	90 g	OPEN	N/A

Cut Sheet/Continuous Sheet Switching Mechanism

Top Feed (for cut sheet paper)

When cut sheet paper is used, place the change lever in the Top Feed position.

As the platen turns, the platen gear causes the idle gear to rotate.

At this time, the rear and front pressure rollers press against the platen and feed the cut sheet.

The cut sheet detection lever enables the cut sheet detection switch, which is located on the main control board. This places the printer in the cut sheet mode.

When cut sheet paper is placed between the platen and the paper chute, the printer automatically feeds the sheet to the print start position.

Rear/Bottom Feed (for continuous feed paper)

When the continuous feed paper is used, either with the rear tractor, optional bottom tractor or optional pull tractor, place the change lever in the Rear/Bottom Feed position.

When the change lever is placed in this position, the reset spring pushes the change gear. In this position, the idle gear is engaged with the bottom tractor unit drive gear and the tractor gear. As the platen turns, power is transferred from the platen gear - to the idle gear - to the change gear - and to the push tractor shaft.

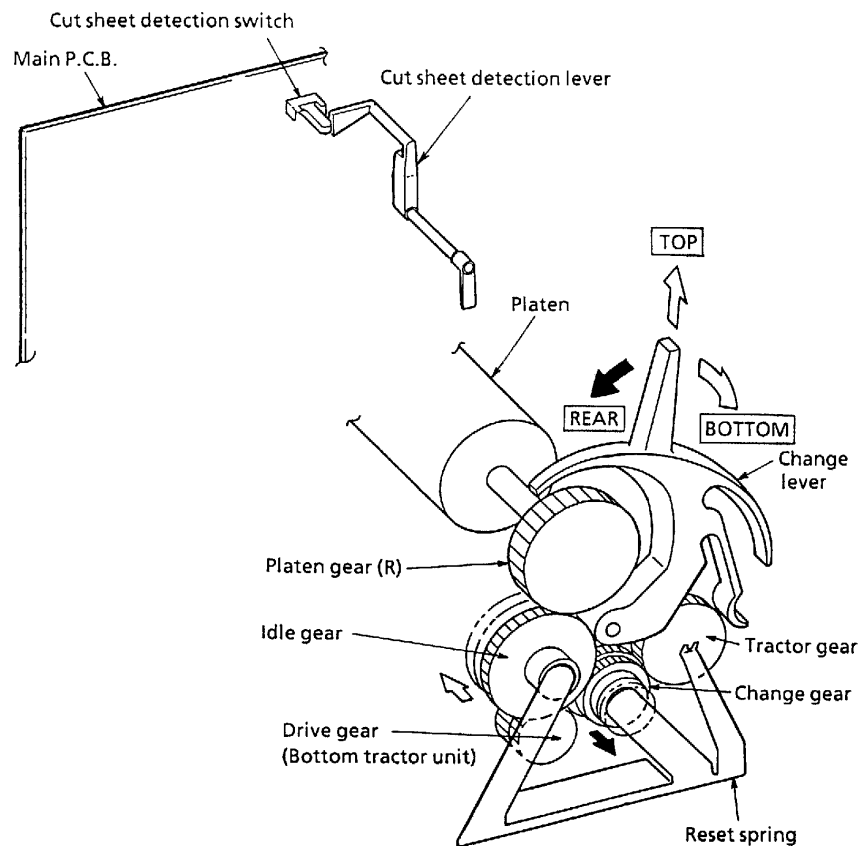

2-32.tif

Cut Sheet Paper Feed Operation

As the line feed motor rotates, power is transferred through decelerating gears (line feed idler gear, platen gear) to the platen.

When using cut sheet paper, the change lever must be in the TOP position so the platen and pressure rollers can feed the paper. This also disengages the push tractor.

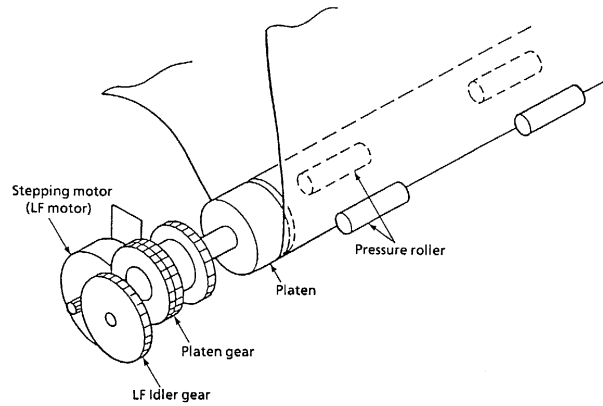

Continuous Paper Feed (Rear Tractor Mechanism)

2-33.tif

As the platen rotates, power is transferred to the tractor gear from the platen gear, the idler gear and the change gear. The tractor gear drives the pin tractor belts which feed the continuous paper.

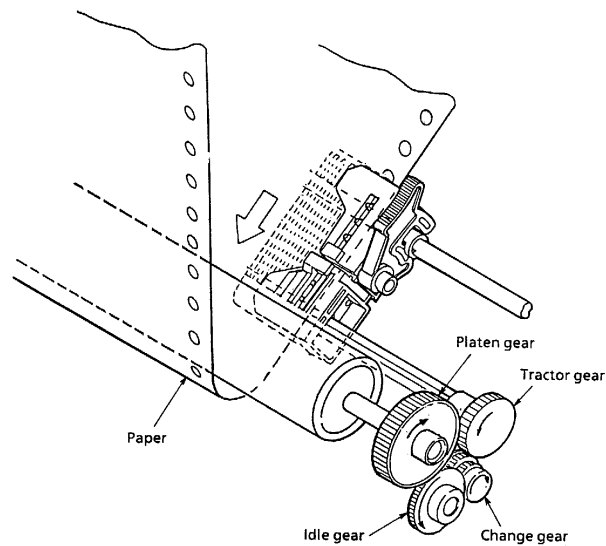

Continuous Paper Feed (Pull Tractor Mechanism)

2-34.tif

Bottom feed of continuous sheets is possible only when an optional pull tractor unit is installed.

As the platen rotates, power is transferred to the drive gear from the LF idler gear, the platen gear, idler gear B and idler gear A. The drive gear turns the pull tractor assembly which feed the continuous paper.

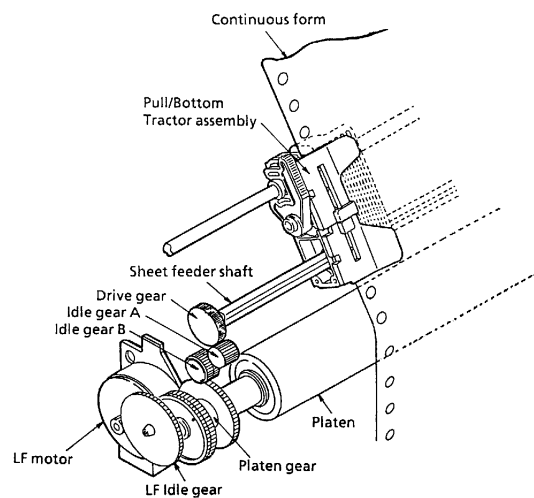

2-36.tif

Continuous Paper Feed (Bottom Tractor Feed Mechanism)

As the platen rotates, power is transferred to the drive gear from the platen gear, the idle gear and the tractor change gear. The drive gear turns the pin tractor belts on the bottom tractor feed unit to feed the continuous paper.

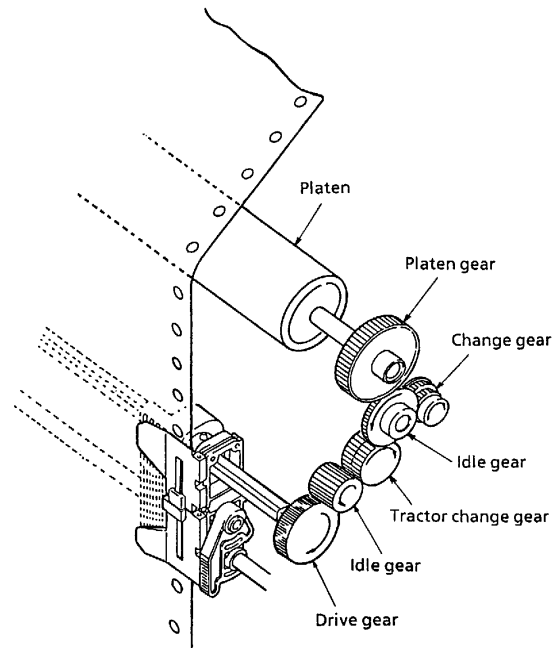

2-37.tif

Continuous Paper Feed (Push/Pull Tractor Mechanism)

This mechanism consists of an optional pull tractor and a standard push tractor mechanism.

Continuous paper is fed by these two tractors at the same time.

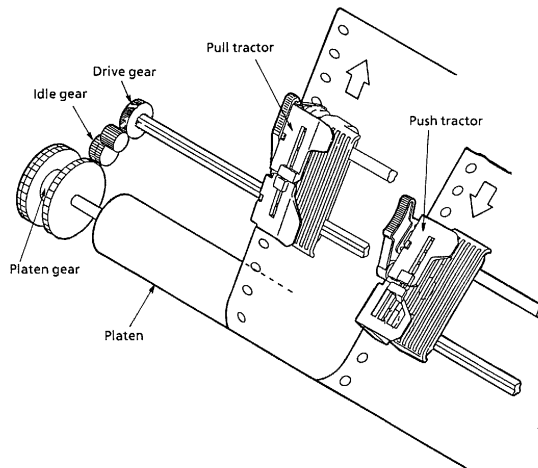

2-35.tif

2.2.06 Paper Detection Mechanism

Top Feed Paper Detection

When the cut sheet paper is inserted into the printer, Point A of Paper Near End Lever - B is pushed backward rotating Paper Near End Lever - A.

As Paper Near End Lever - A rotates, it contacts the Rear Sensor Lever, rotating it.

The Rear Sensor Lever rotates, unblocking the Rear / Top Paper End Sensor.

Rear Feed Detection

When paper is fed from the rear push tractor, Point B is pushed backward rotating Paper Near End Lever - A.

As Paper Near End Lever - A rotates, it contacts the Rear Sensor Lever, rotating it.

The Rear Sensor Lever rotates, unblocking the Rear / Top Paper End Sensor.

Bottom Feed Detection

When the paper is fed from the bottom of the printer, Point C is pushed, rotating the Bottom Paper End Lever.

As the Bottom Paper End Lever rotates, it contacts and rotates the Bottom Sensor Lever.

The Bottom Sensor Lever rotates, unblocking the Bottom Paper End Sensor.

NOTE:

The method for detecting a paper-end condition is in the reverse order, that is, paper-end is detected when the Paper End Sensor is blocked.

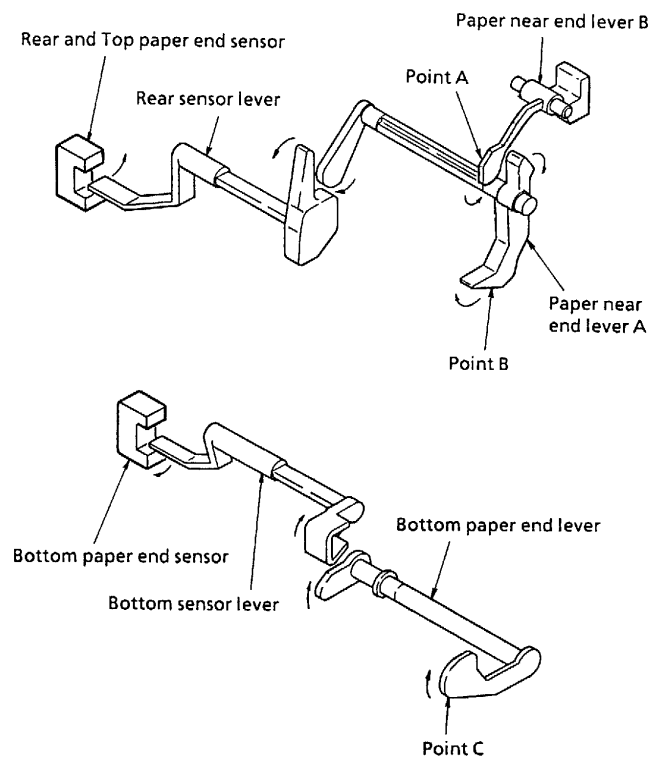

2-39.tif

2.2.07 Support Protector Mechanism

During printer initialization, the support protector is latched in the stored position (approximately 5 mm from the left bracket of the main frame).

Just before paper is loaded, the printhead moves towards the left bracket and unlatches the support protector.

As the printhead moves to the right, the support protector reset spring pushes the support protector toward the center of the platen. With the support protector in this position, the ribbon protector and the support protector prevent the leading edge of the paper from curling or folding.

Once the paper is ejected, the printhead slowly moves towards the left bracket. The support protector is latched in the stored position when it is pushed to approximately 5 mm from the left bracket.

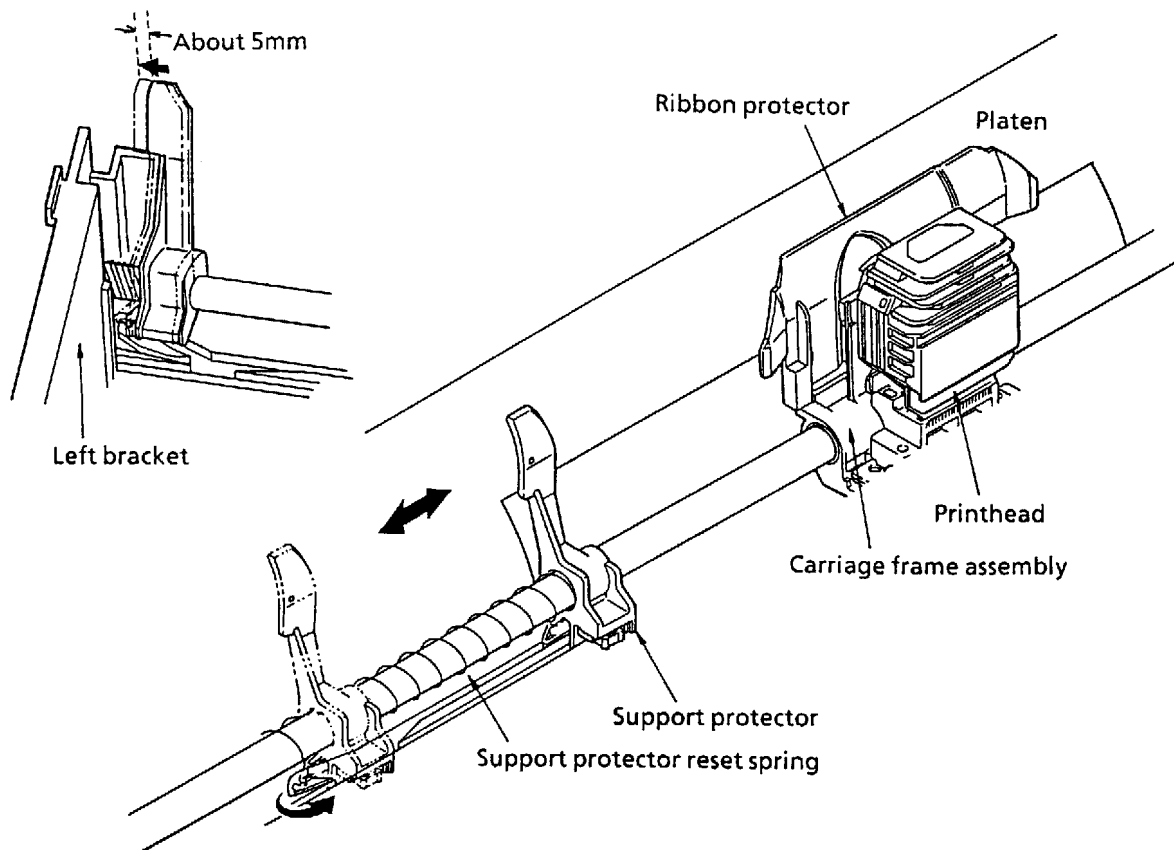

2.2.08 Automatic Paper Load

The Microline 590/591 printers will automatically detect cut sheet paper and feed the paper to the TOP OF FORM position.

Cut Sheet Paper

Set the change lever to the TOP FEED position.

NOTE:

When the change lever is in the TOP FEED position, the cut sheet detection lever contacts the cut sheet detection switch (BASW) which is located on the main control board.

Insert the sheet of paper between the platen and the paper chute.

Once paper is detected at the paper end sensor and the amount of time selected on the *Wait Time* setting of the menu has lapsed, the line feed motor will feed the paper until the leading edge of the paper reaches the top of form position.

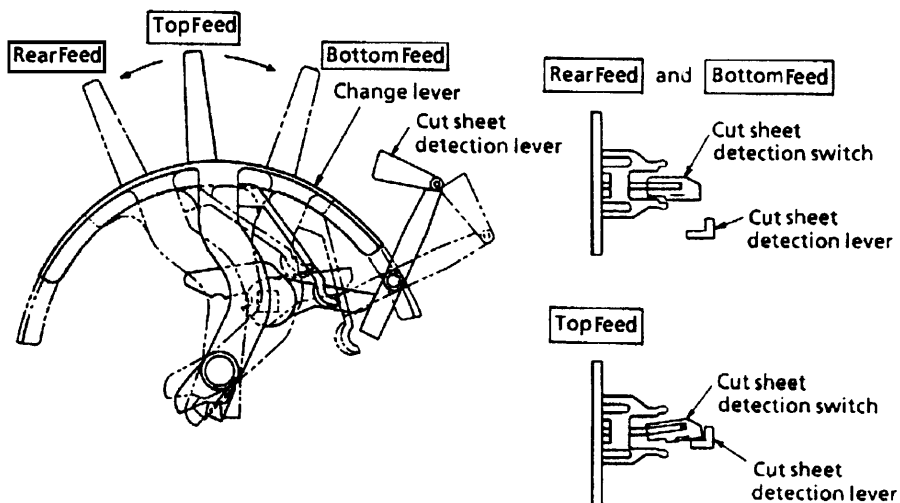
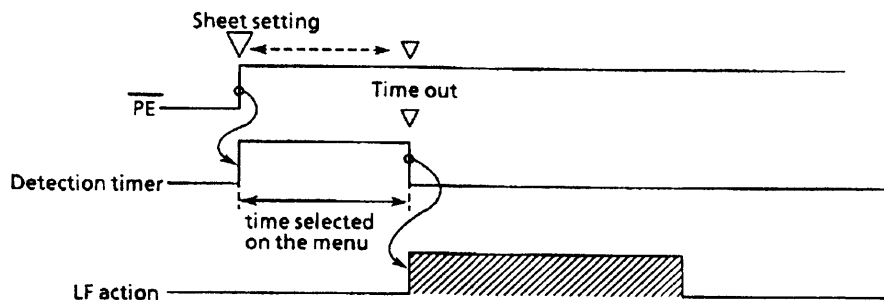

2-2-08.pcx

Continuous Feed Paper

Set the change lever to either the REAR FEED or BOTTOM FEED position.

NOTE:

When the change lever is in the REAR FEED or BOTTOM FEED position, the cut sheet detection lever does not contact the cut sheet detection switch (BASW) which is located on the main control board.

Place continuous feed paper in the appropriate tractor.

Press the "FF/LOAD" switch.

The line feed motor will feed the paper until the leading edge of the paper to the top of form position.

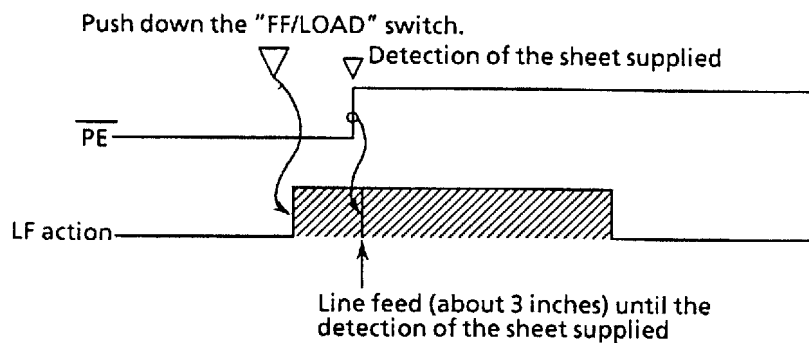

2-42.tif

2.2.09 Paper Park

If continuous feed paper is installed and printing on cut sheet paper is desired, it is not necessary to unload the continuous feed paper. The Paper Park feature provides a means of retracting the continuous feed paper from the paper path, to allow feeding of the cut sheet paper.

Paper Park Operation

Make sure the change lever is in the REAR FEED or BOTTOM FEED position.

Press the "PARK" switch on the operation panel.

A reverse line feed operation retracts the paper until paper-end occurs or 19 inches of paper have been retracted.

NOTE:

Retracting 19 inches of paper without detecting a paper-end condition causes the line feed operation to stop. The line feed operation stops because the printer assumes a jam has occurred.

The operator can press the SEL switch to reset the ALARM LED and press the PARK switch to continue the park operation.

This operation may be useful when length of the paper to be parked is greater than 19 inches.

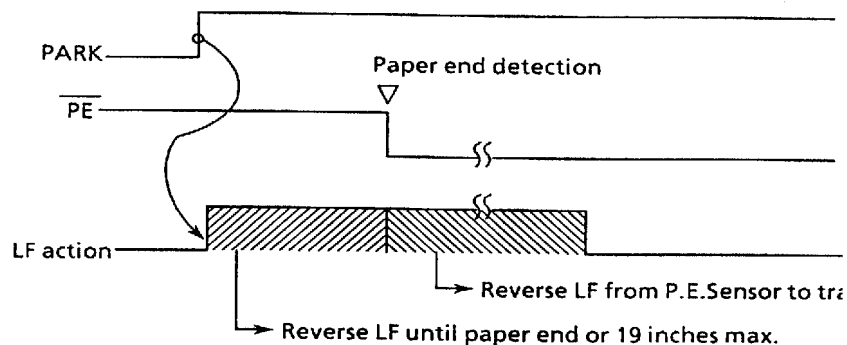

2-43.tif

SECTION THREE
MAINTENANCE

3.1 OVERVIEW

3.1.01 General Information

This section lists the parts replacement, adjustment, cleaning, lubrication, and shipping procedures.

Disassembly should not be performed unless absolutely necessary. **NEVER** perform disassembly on a malfunctioning printer until you have followed the failure analysis procedures in Section Four of this Service Handbook.

Follow the procedures listed in *Adjustments and Service Settings*. Adjustments may be required when either consumable or parts are replaced. Failure to perform these procedures could result in unnecessary service calls.

Proper performance of maintenance and cleaning will help to achieve the best possible print quality from the printer.

3.1.02 Maintenance Tools

The following tools are required to service the printer.

- #2 Phillips Screwdriver (with magnetic tip)
- Straight-slot Screwdriver
- Needle Nose Pliers (4 Inch)
- Wire Cutters
- Digital Multimeter
- Feeler Gauge (capable of measuring .014 inches)
- Shop Vacuum
- Clean, soft, and lint-free Cloth
- All-Purpose Cleaner
- Contact Kleen (Okidata P/N 51802301)
- Platen Cleaner
- Machine Grease
- Machine Oil

3.1.03 Maintenance Precautions

1. Do not disassemble the unit if it is operating normally.
2. Before starting disassembly and assembly, always turn the AC power switch OFF and pull out the AC plug.
3. Detach the interface cable, if installed.
4. Do not remove parts unnecessarily. Try to keep disassembly to a minimum.
5. Use the recommended maintenance tools.
6. When disassembling, follow the listed sequence. Failure to follow the correct sequence may result in damaged parts.
7. Since screws, collars and other small parts are easily lost, they should be temporarily attached to the original positions.
8. When handling circuit boards use extreme care. Integrated circuits (microprocessors, ROM, and RAM) can be destroyed by static electricity.
9. Do not place printed circuit boards directly on conductive surfaces.
10. Follow the recommended procedures when replacing assemblies and units.
11. Perform the printhead gap adjustment procedure (Refer to Section 3.3 of this Service Handbook) when the any of the following occur.

Print Quality is darker on one side of the document.

Parts are replaced

1. Printhead (3.2.02)
2. Space Motor Assembly (3.2.11)
3. Space Rack (3.2.13)
4. Guide Rail (3.2.15)
5. Platen Assembly (3.2.19)
6. Carriage Shaft (3.2.25)

3.2 DISASSEMBLY/ASSEMBLY PROCEDURES

General Information

This section contains the printer disassembly procedures. Only the removal procedures are explained here. Reverse the procedure for the installation.

At the bottom of each procedure is a listing of the parts covered in that procedure. The Okidata part number, item description, comment (RSPL, Option, Consumable) and cross-reference to Appendix B is provided for each part. Items included in the Recommended Spare Parts List are indicated by the acronym RSPL. N/A will appear where a part number is not available.

590 indicates that the item is specific to the Microline 590.

591 indicates that the item is specific to the Microline 591.

Both indicates that the item is common to both printers.

<input type="checkbox"/> Part Number	Item Description	Comment	Appendix B Reference
---	---------------------	---------	-------------------------

This Service Handbook lists the disassembly procedures for major components of the unit. Okidata DOES NOT recommend disassembling a unit which is operating normally. If you decide to perform disassembly during this training, Okidata recommends that you perform *only* the disassembly procedures for RSPL items. All other procedures are provided to assist you in identifying parts. It is not likely that you will perform these procedures while servicing the unit.

Be sure to read all notes, cautions, and warnings, as they contain important information regarding disassembly / assembly.

3.2.01 Preliminary Items

1. Press the AC switch (1) and power off the printer.
2. Remove the paper, if installed (2).
3. Detach the AC power cord (3).
4. Detach the interface cable, if installed (4).

<input type="checkbox"/>	P/N 56609701	Cord: AC	RSPL	Both	B.2.02
<input type="checkbox"/>	P/N 56624101	Cord: AC 220V (ML Series) Right Angle	Option RSPL	Both	B.2.02
<input type="checkbox"/>	P/N 56624401	Cord: AC 240V	Option RSPL	Both	B.2.07
<input type="checkbox"/>	P/N 70000803	Kit: Parallel Interface Plug'n'Play Accessory	Option	Both	B.2.07
<input type="checkbox"/>	P/N 70012801	Kit: RS232-C Serial Interface	Option	Both	B.2.07

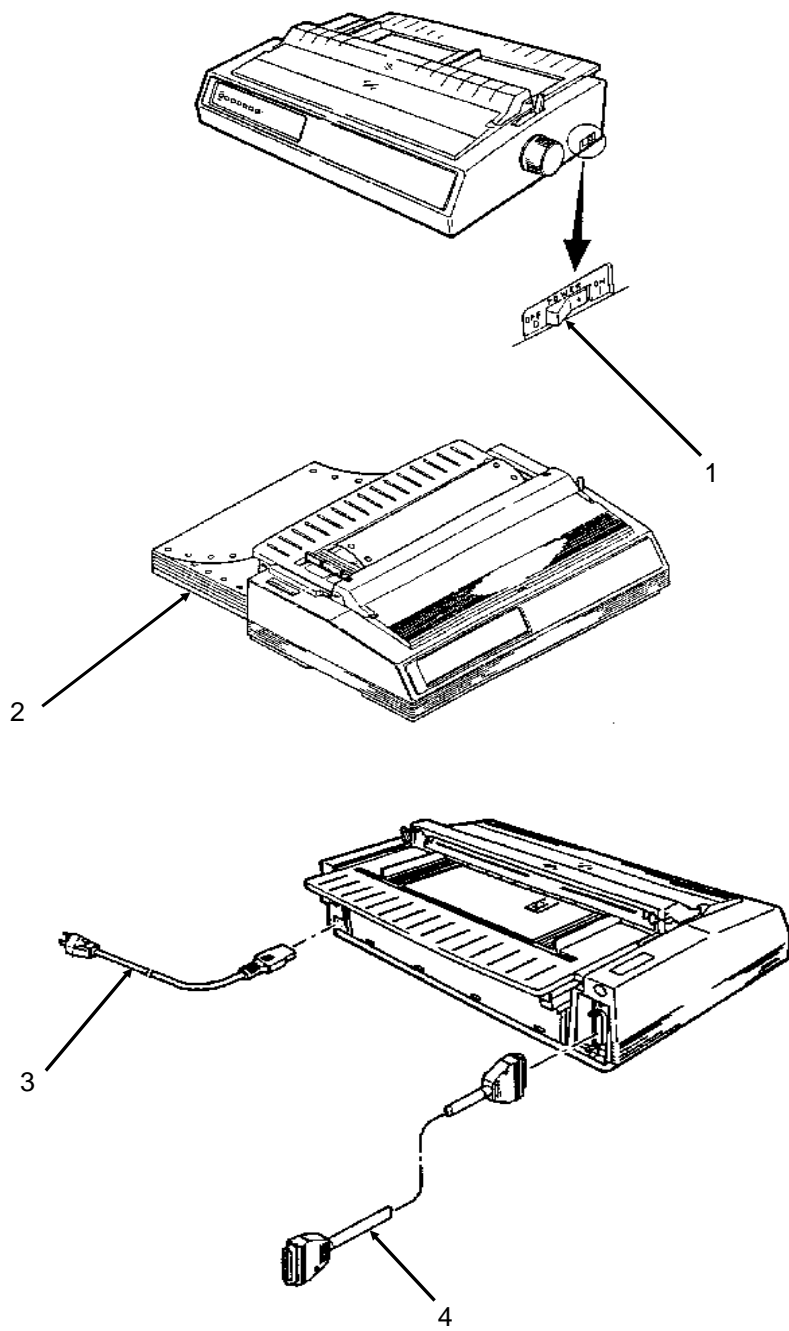

3-2-01.pcx

3.2.02 Printhead Assembly

1. Perform this procedure: 3.2.01.
2. Open the access cover (1).
3. Lift and remove the ribbon. (*Not shown*)
4. Pull the head clamp (2) towards the right and then rotate it up to release the printhead (3).
5. Pull the printhead straight up to remove it.

NOTE:

Installation

After installing the printhead, check the printhead gap adjustment. Refer to Section 3.3 of this Service Handbook.

<input type="checkbox"/>	P/N 52106001	Ribbon: Black	Consumable	Both	B.2.09
<input type="checkbox"/>	P/N 52106002	Ribbon: Color	Consumable	Both	B.2.09
<input type="checkbox"/>	P/N 50707401	Clamp: Head	RSPL	Both	B.2.06
<input type="checkbox"/>	P/N 50217201	Assembly: Printhead	RSPL	Both	B.2.02

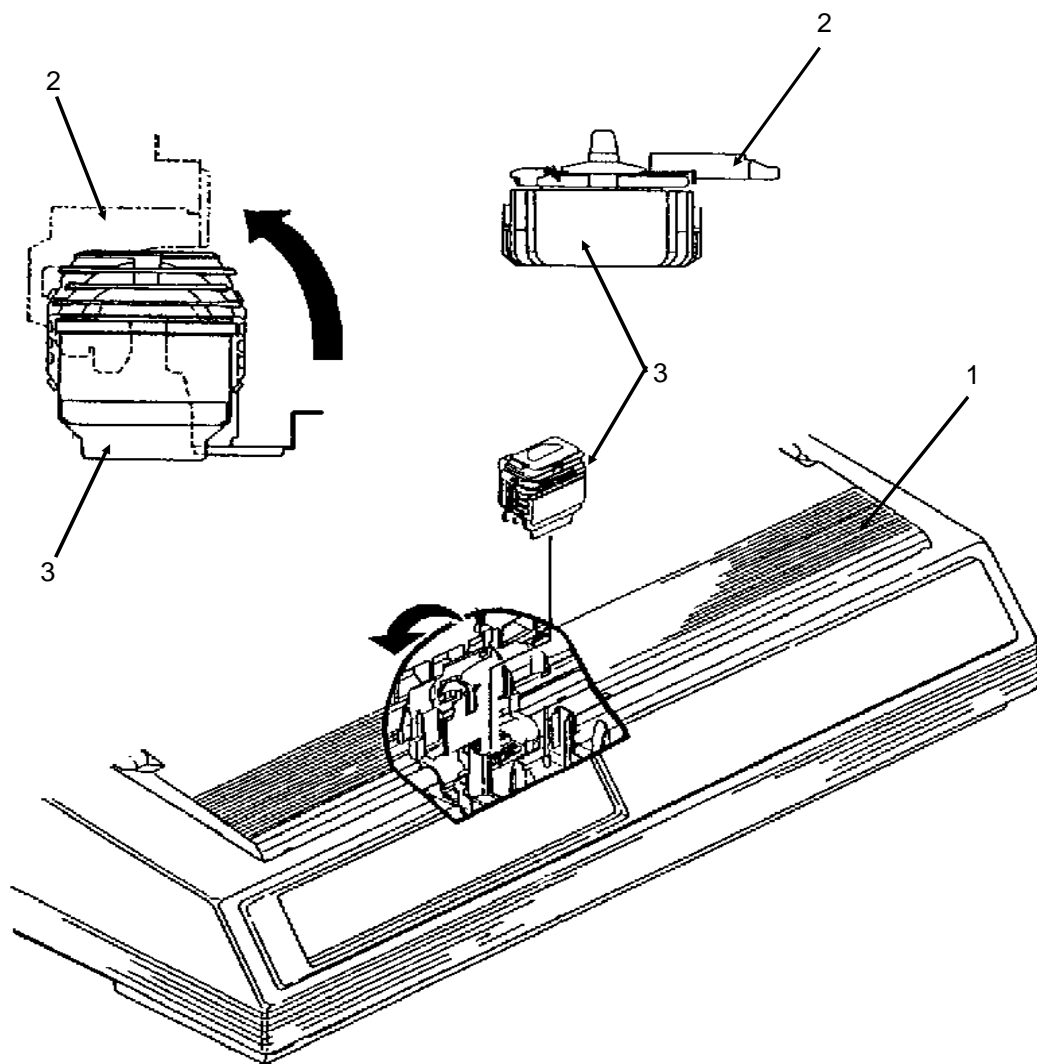

3-2-02.pcx

3.2.03 Ribbon Protector

CAUTION

You MUST use a straight slot screwdriver to release the ribbon protector. If you attempt to lift the protector without releasing the tabs, the protector will break.

1. Perform these procedures: 3.2.01, and 3.2.02.
2. Open the pull-up roller cover (1).
3. Use a straight-slot screwdriver to release the extensions (2) from the carriage frame set (3).
4. Lift the ribbon protector (4) straight up and remove it.

P/N 53562801 Protector: Ribbon RSPL Both B.2.06

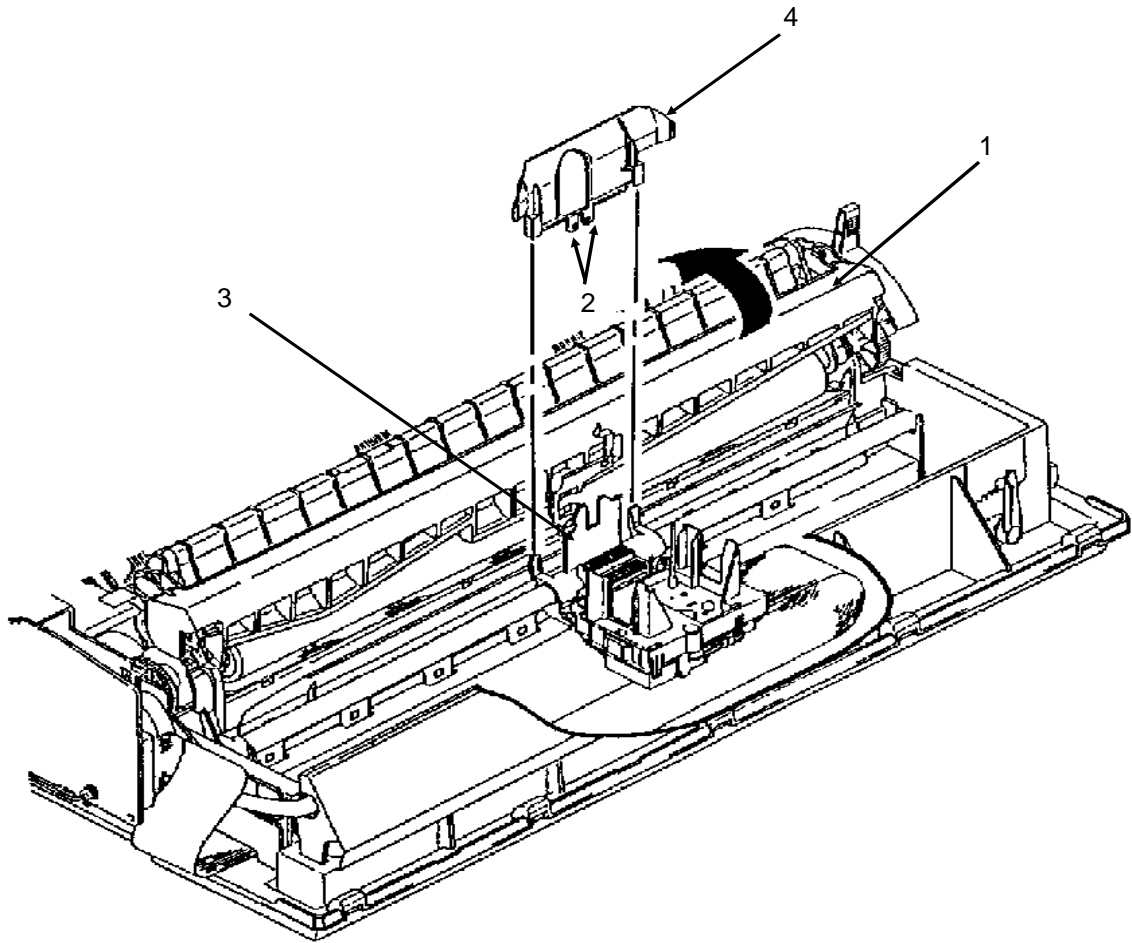

3-2-03.pcx

3.2.04 Gear Case Assembly

1. Perform these procedures: 3.2.01, and 3.2.02.
2. Use a straight-slot screwdriver to release the four claws (1) of the gear case assembly (2).
3. Lift and remove the gear case assembly.

NOTE:

Lubrication

When lubricating, refer to Section 3.5 of this Service Handbook.

P/N 51228501 Gear: Case (Assembly) RSPL Both B.2.06

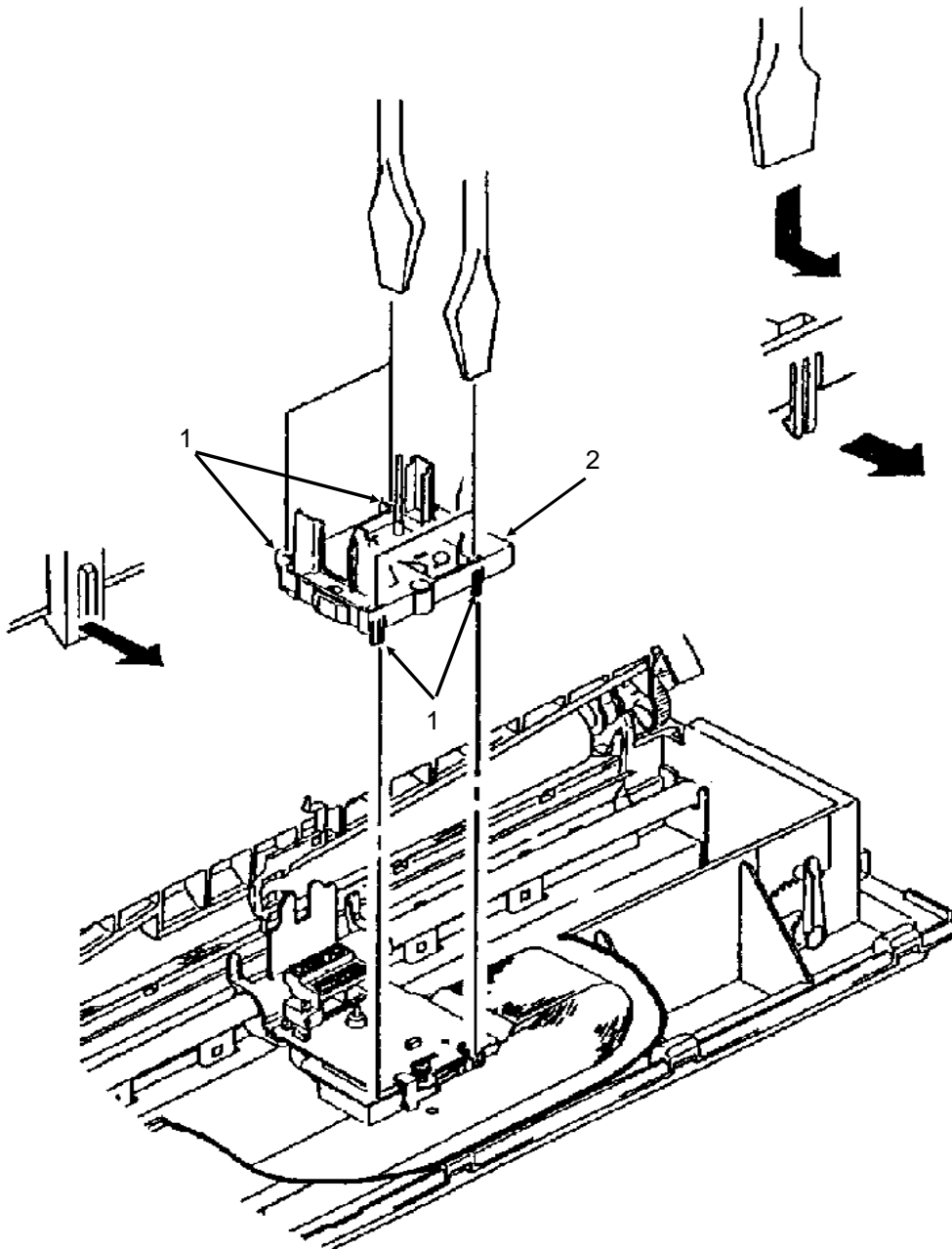

3-2-04.pcx

3.2.05 Pull-up Roller Assembly

1. Perform this procedure: 3.2.01.
2. Open the access cover (1).
3. Open the cover of the pull-up roller assembly (2).
4. Press at A while rotating the assembly towards the back of the printer.
5. Remove the assembly.

NOTE:

Lubrication

When lubricating, refer to Section 3.5 of this Service Handbook.

<input type="checkbox"/>	P/N 53341501 (Narrow)	Roller: Pull Up Assembly	RSPL	590	B.2.04
<input type="checkbox"/>	P/N 53341601	Roller: Pull Up Assembly (Wide)	RSPL	591	B.2.04

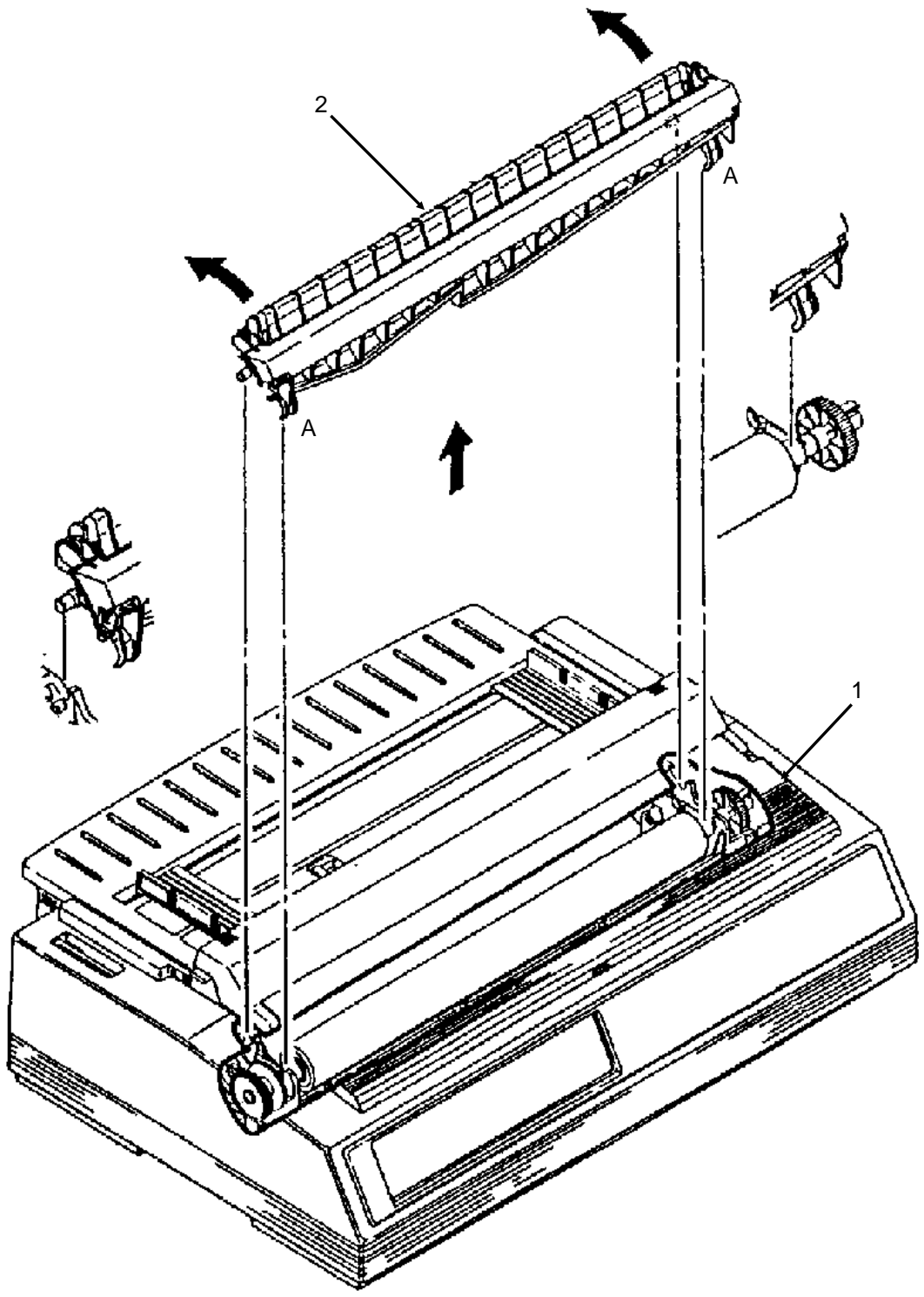

3-2-05.pcx

3.2.06 Upper Cover, Access Cover, and Sheet Guide Assemblies

1. Perform this procedure: 3.2.01.
2. Pull the platen knob (1) straight out and remove it.
3. Set the change lever (2) to the bottom feed position (toward the rear of the printer).
4. Insert a flat-blade screwdriver into the grooves (3) of the frame and pry the upper cover (4) away from the frame.
5. Raise the front side of the upper cover assembly.
6. Tilt the upper cover assembly toward the rear to disengage the claws (not shown) at the rear of the frame.
7. Lift the upper cover assembly and remove it.

CAUTION:

Do not rotate the access cover past the vertical when removing it or you will break the tab extensions.

8. Raise the access cover assembly (5) until it is vertical, then lift it straight up to remove it.
9. Remove the sheet guide assembly (6).
10. Note the position of the cover (B) <for card slot> (7). This is part of the upper cover and should not be removed. No font cards are currently available.

NOTE:

When cleaning, refer to Section 3.4 of this Service Handbook.

<input type="checkbox"/>	P/N 51009401	Guide: Sheet (Narrow)	RSPL	590	B.2.01
<input type="checkbox"/>	P/N 51009501	Guide: Sheet (Wide)	RSPL	591	B.2.01
<input type="checkbox"/>	P/N 53066901	Cover: Upper (Narrow)	RSPL	590	B.2.01
<input type="checkbox"/>	P/N 53067001	Cover: Upper (Wide)	RSPL	591	B.2.01
<input type="checkbox"/>	P/N 53067101	Cover: Access (Narrow)	RSPL	590	B.2.01
<input type="checkbox"/>	P/N 53067201	Cover: Access (Wide)	RSPL	591	B.2.01
<input type="checkbox"/>	P/N 53067301	Cover: (B) for card slot	RSPL	Both	B.2.02
<input type="checkbox"/>	P/N 53562601	Knob: Platen (ML500 Series)	RSPL	Both	B.2.02

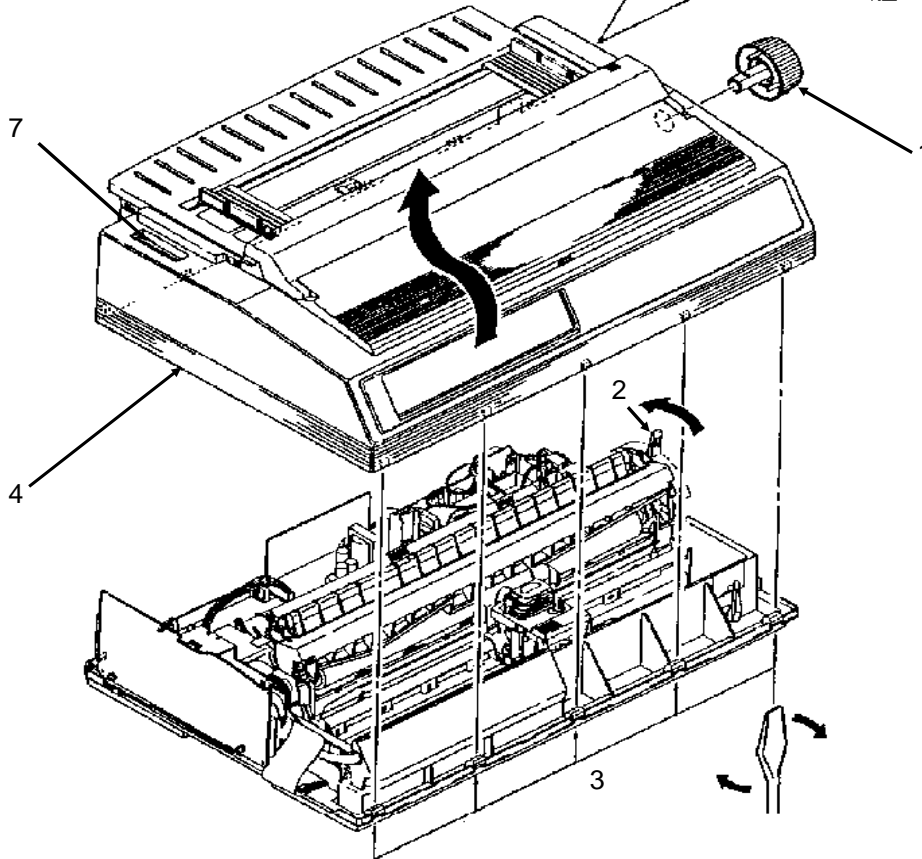
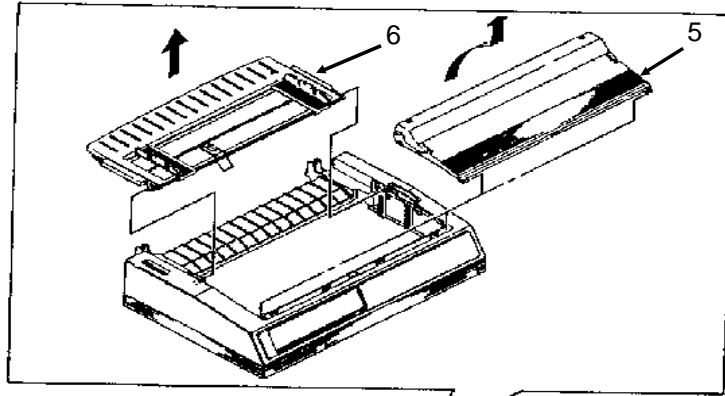

3-2-06.pcx

3.2.07 Control Board (AKGI)

1. Perform these procedures: 3.2.01, and 3.2.06.
2. Remove the two screws (1).
3. Release the control board (AKGI) (2) from the bracket (3).
4. Tilt the board to access the connectors.
5. Detach connectors CN7 - operator panel (4), CN8 - carriage cable (5), CN3 - power supply (6), and CN6 - line feed motor (7).
6. Remove the board.

NOTE:

Installation

The bottom sensor lever must be positioned in the SNS3 sensor (8).

The rear sensor lever must be positioned in the SNS1 sensor (9).

The cut sheet/continuous sensor lever must be positioned below the BASW sensor (10). The lever should contact the sensor only when the change lever is in the top feed (middle) setting.

The IC: EEPROM is soldered in on the board.

<input type="checkbox"/>	P/N 55937401	PCB: AKGI (w/o ROM)	RSPL	Both	B.2.02
<input type="checkbox"/>	P/N 55938301	IC: EEPROM BR93CC46A	RSPL	Both	B.2.02

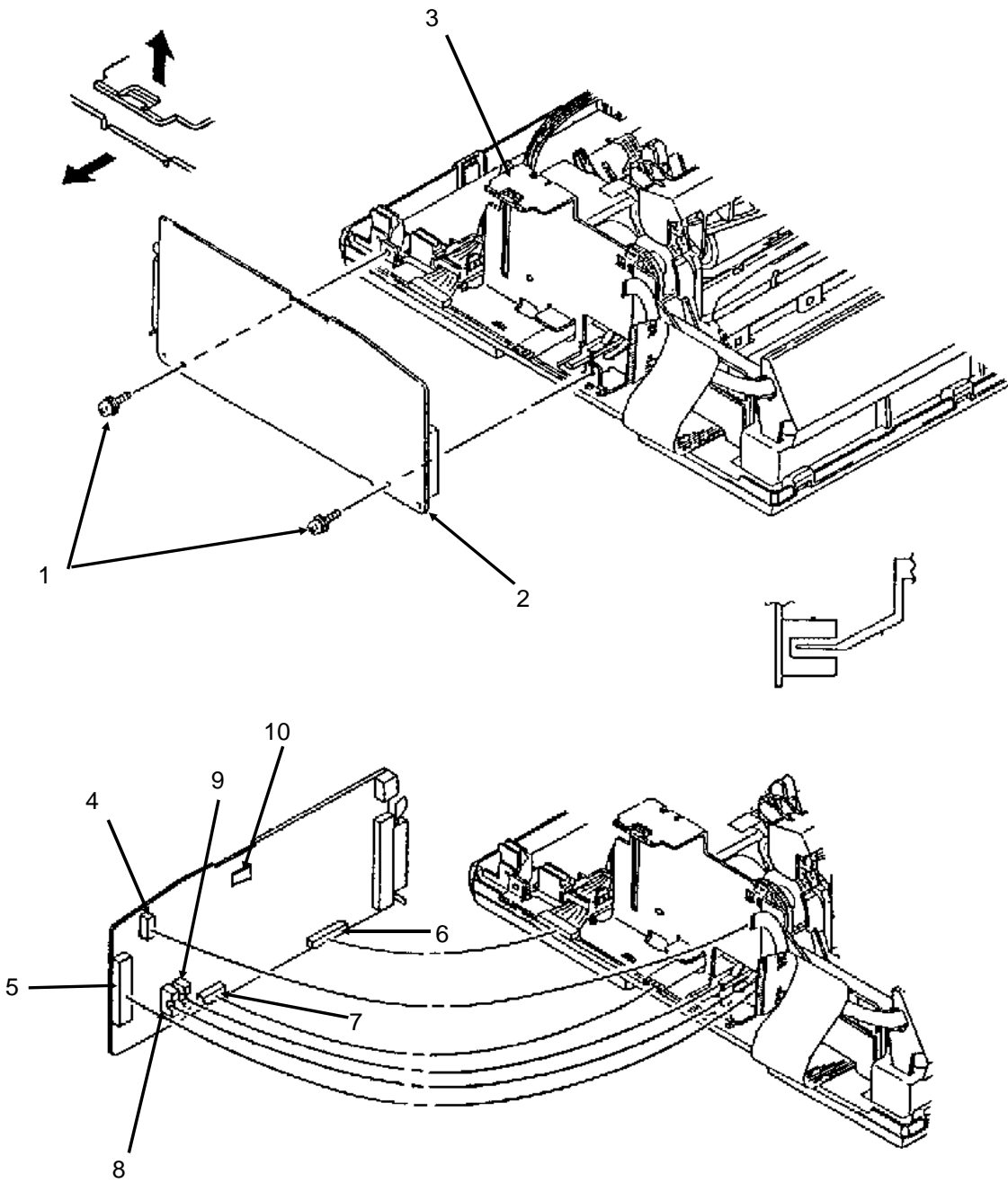

3-2-07.pcx

3.2.08 Power Supply Assembly

1. Perform these procedures: 3.2.01, and 3.2.06.
2. Detach the cable from connector CN2 (1) of the power supply board (2).
3. Detach the cable from connector CN3 (3) of the control board (4).
4. Use a straight slot screwdriver to release the claws and remove the cable clamp (5).
5. Remove the cable (6).
6. Release the tab and remove the cover (7).
7. Remove the screw (8) and detach the ground cable (9).
8. Lift the AC inlet (10) and the AC switch (11) from the main frame (12).
9. Remove the two screws (13).
10. Slide the power supply in the direction of arrow A to clear the claws of the base frame.
11. Lift and remove the power supply assembly.

NOTE:

The 5 amp fuse is on the end of the board facing the AC inlet and the AC switch.

The 2.5 amp fuse is near the middle of the board.

When installing, verify that the AC inlet and AC switch are oriented correctly.

<input type="checkbox"/>	P/N 50707501	Clamp: Cord	RSPL	Both	B.2.02
<input type="checkbox"/>	P/N 56302901	Fuse: 2.5A 120V	RSPL	Both	B.2.02
<input type="checkbox"/>	P/N 56305901	Fuse: (GGS 5) 120V	RSPL	Both	B.2.02
<input type="checkbox"/>	P/N 56306001	Fuse: 3.15 A (230/240V)	Option RSPL	Both	B.2.08
<input type="checkbox"/>	P/N 56306001	Fuse: 3.15 A (230/240V)	Option RSPL	Both	B.2.02
<input type="checkbox"/>	P/N 56412101	Power Supply 120V	RSPL	590	B.2.02
<input type="checkbox"/>	P/N 56412102	Power Supply 120V	RSPL	591	B.2.02
<input type="checkbox"/>	P/N 56412201	Power Supply 230-240V	Option RSPL	590	B.2.02/07
<input type="checkbox"/>	P/N 56412202	Power Supply 230-240V	Option RSPL	591	B.2.02/07

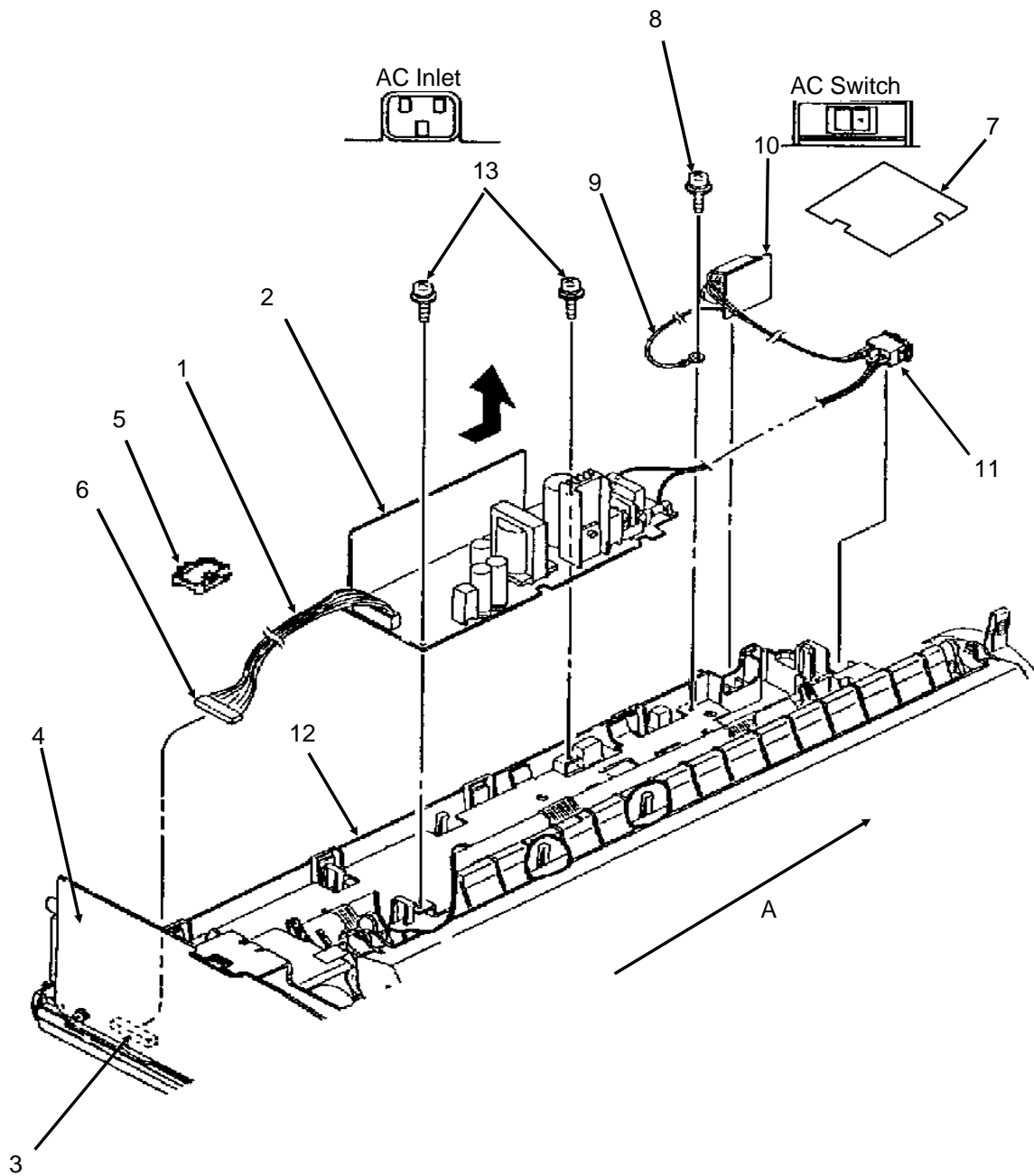

3-2-08.pcx

3.2.09 Operator Panel PCB (LEOP)

1. Perform these procedures: 3.2.01, 3.2.06. and 3.2.07.
2. Cut the nylon tie and release the cable. (*Not shown*)
3. Disengage the claws (1) on both sides of the frame.
4. Lift the operator panel assembly (2) straight up and remove it.
5. Open eight claws (3) and remove the operator panel PCB (LEOP) (4) from the operator panel (5).

<input type="checkbox"/>	P/N 53562701	Panel: Operator	RSPL	Both	B.2.02
<input type="checkbox"/>	P/N 55937501	PCB: LEOP (Operator Panel)	RSPL	Both	B.2.02

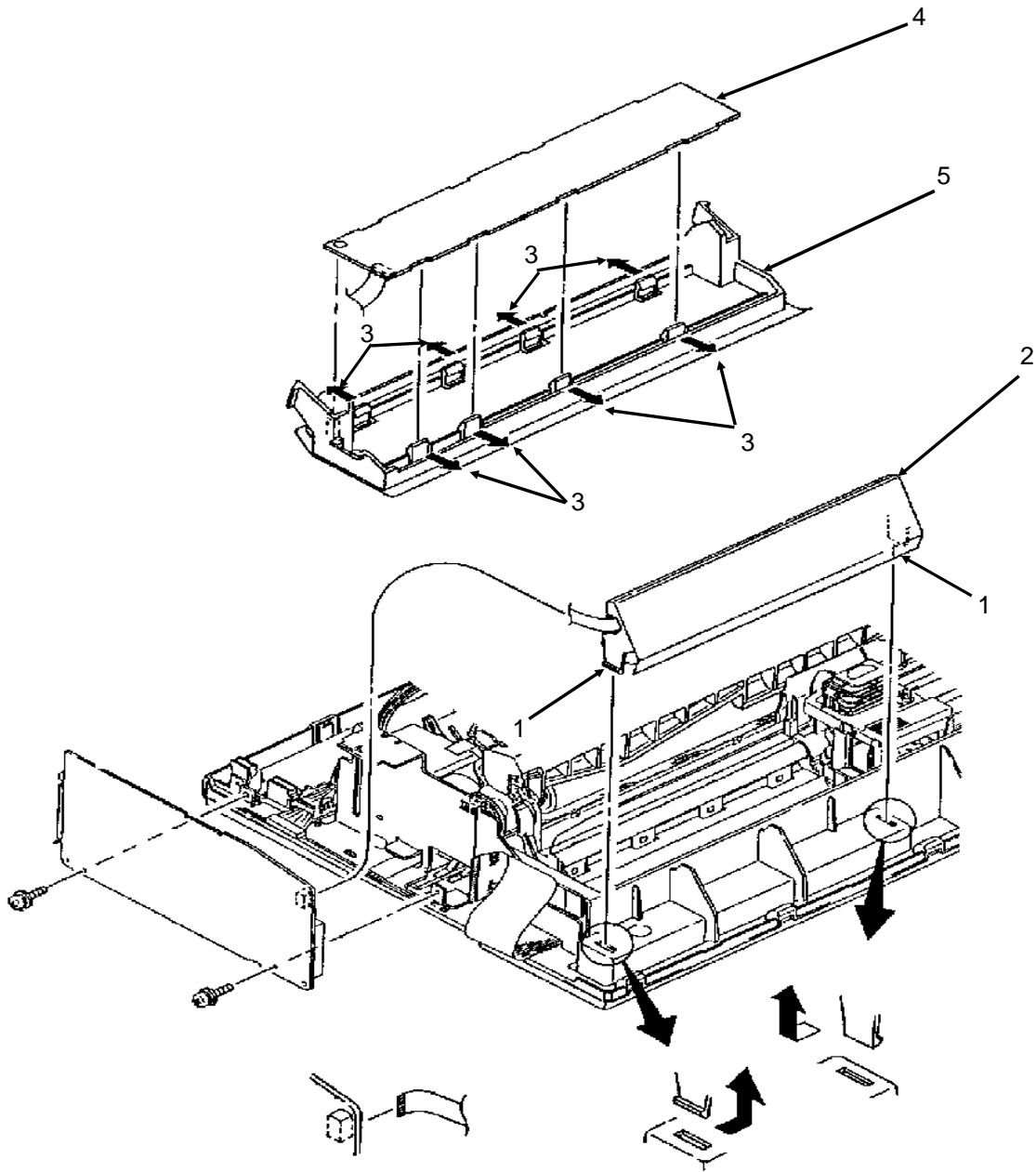

3-2-09.pcx

3.2.10 PC Connector

1. Perform these procedures: 3.2.01, 3.2.02, and 3.2.04.
2. Remove the two screws (1).
3. Remove the PC connector (2).

NOTE:

Installation

Do not touch the contacts of the PC connector.

Do not touch the contacts of the space motor (3).

Cleaning

When cleaning, refer to Section 3.4 of this Service Handbook.

P/N 56729601 Connector: PC HD40 RSPL Both B.2.06

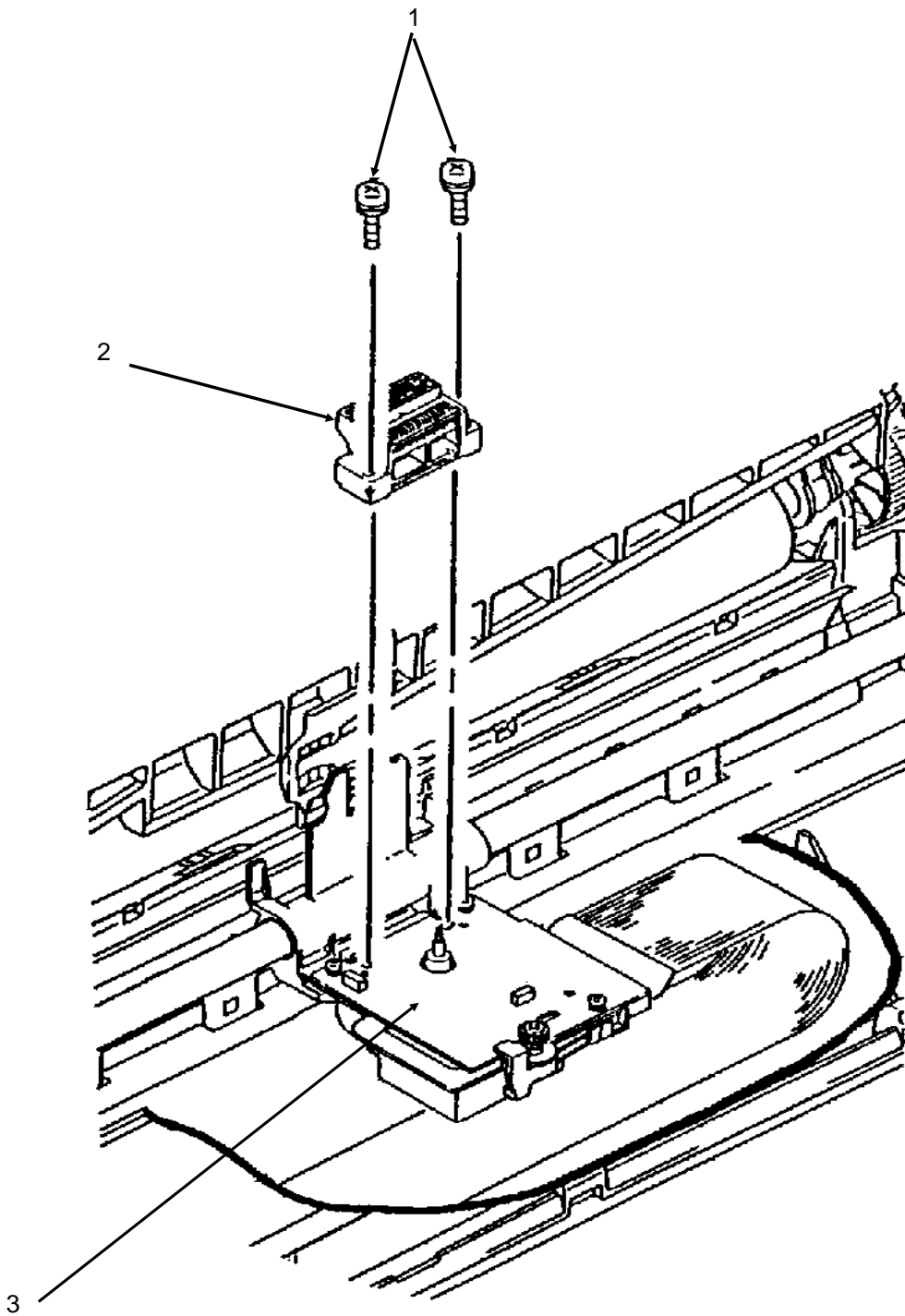

3-2-10.pcx

3.2.11 Space Motor and Roller Guide Assemblies

1. Perform these procedures: 3.2.01, 3.2.02, 3.2.04, and 3.2.10.
2. Remove the three screws (1).
3. Lift the space motor assembly (2).
4. Remove the left (3) and right connector holders (4).
5. Remove the roller guide assembly (5) and guide roller spring (6).
6. Use firm pressure to pull the carriage cable (7) out to detach the cable from the space motor assembly.
7. Remove the space motor assembly.

NOTE:

The guide roller assembly includes the guide roller (8), the guide roller holder (9), and the pin (10).

Installation: Position the guide roller assembly first.

The contact side of the cable faces down when the carriage cable is inserted into the connector on the space motor assembly. Work the cable from side to side until it is fully seated in the connector. No contacts should be visible.

After installing the space motor assembly, check the printhead gap adjustment. Refer to Section 3.3 of this Service Handbook.

When lubricating, refer to Section 3.5 of this Service Handbook.

<input type="checkbox"/>	P/N 53343001	Holder: Connector (L)	RSPL	Both	B.2.06
<input type="checkbox"/>	P/N 53343101	Holder: Connector (R)	RSPL	Both	B.2.06
<input type="checkbox"/>	P/N 56510401	Motor: Space Assembly	RSPL	Both	B.2.06
<input type="checkbox"/>	P/N 53343301	Guide: Roller Assembly		Both	B.2.06
<input type="checkbox"/>	P/N 53341901	Roller: Guide	RSPL	Both	B.2.06
<input type="checkbox"/>	P/N 53342001	Holder: Guide Roller	RSPL	Both	B.2.06
<input type="checkbox"/>	P/N N/A	Pin		Both	B.2.06

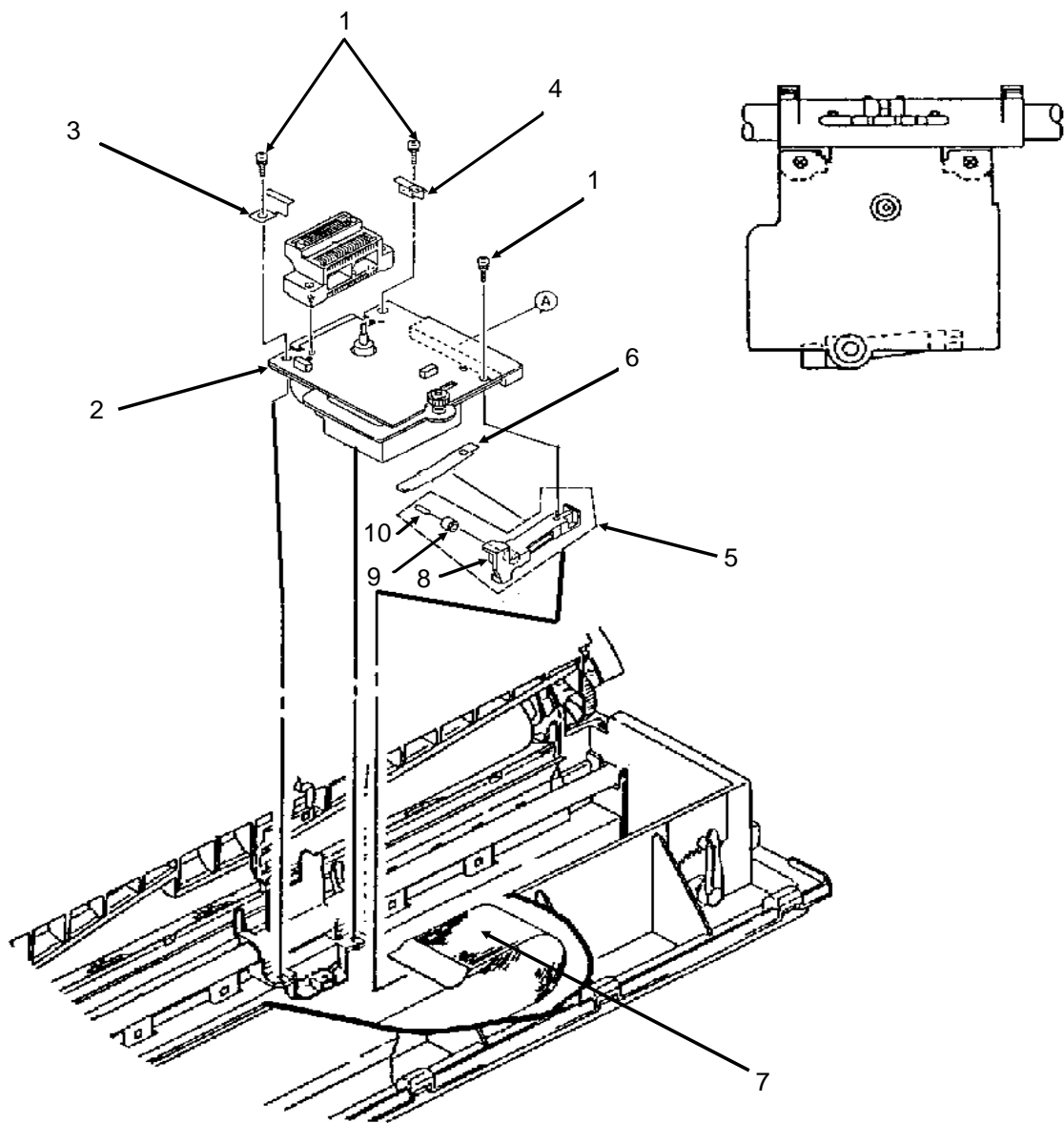

3-2-11.pcx

3.2.12 Carriage Cable

1. Perform these procedures: 3.2.01, 3.2.06, 3.2.07, and 3.2.11.
2. Slightly bow the carriage cable (1) to release it from the claws (2) and the projection on the main frame (3).
3. Remove the carriage cable.

NOTE:

Installation

The contacts on the cable face up when the cable is positioned on the main frame.

The cable end with the 45° angled contacts connects to the gear case assembly.

Do NOT sharply bend the carriage cable. You will slightly bow the cable to position it under the claws and over the projection.

<input type="checkbox"/>	P/N 56627301	Cable: Carriage (Narrow)	RSPL	590	B.2.06
<input type="checkbox"/>	P/N 56627302	Cable: Carriage (Wide)	RSPL	591	B.2.06

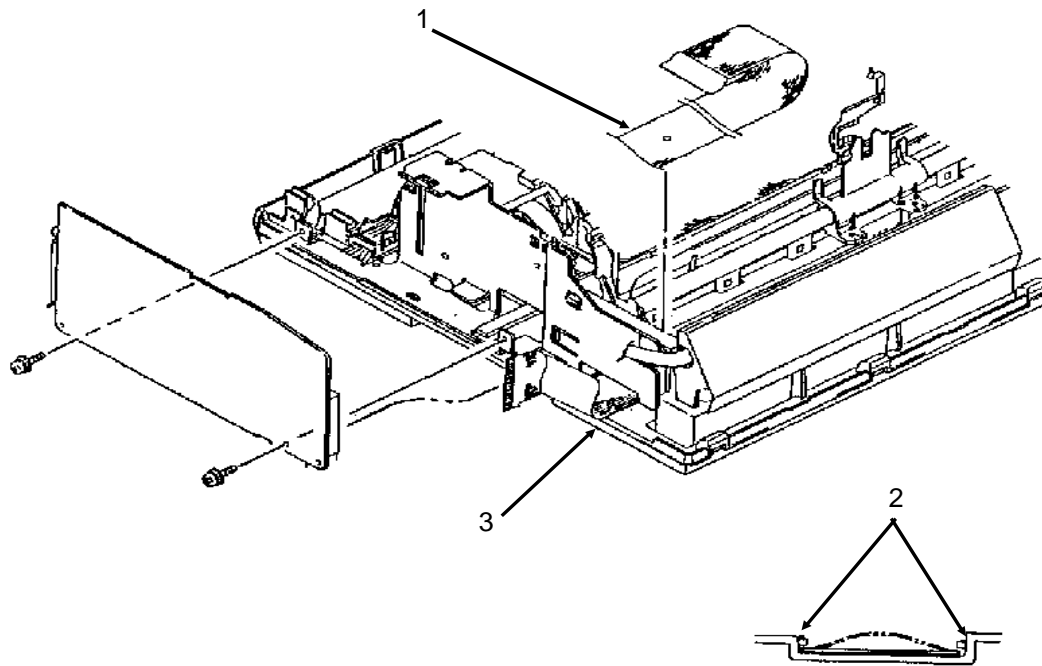

3-2-12.pcx

3.2.13 Space Rack

1. Perform these procedures: 3.2.01, 3.2.02, 3.2.04, 3.2.10, and 3.2.11.
2. Remove the spring (1).
3. Disengage the claws (2) on the both ends of the space rack (3).
4. Pull the space rack straight up and remove it.

NOTE:

Installation

After installing the space rack, check the printhead gap adjustment. Refer to Section 3.3 of this Service Handbook.

Cleaning

When cleaning, refer to Section 3.4 of this Service Handbook.

CAUTION

Do NOT lubricate the space rack. Lubricating the space rack will attract dust. If enough dust accumulates on the space rack, printing problems will occur.

<input type="checkbox"/>	P/N 50923501	Spring: Tension (Space Rack)	RSPL	Both	B.2.03
<input type="checkbox"/>	P/N 53563301	Rack: Space (Narrow)	RSPL	590	B.2.03
<input type="checkbox"/>	P/N 53563401	Rack: Space (Wide)	RSPL	591	B.2.03

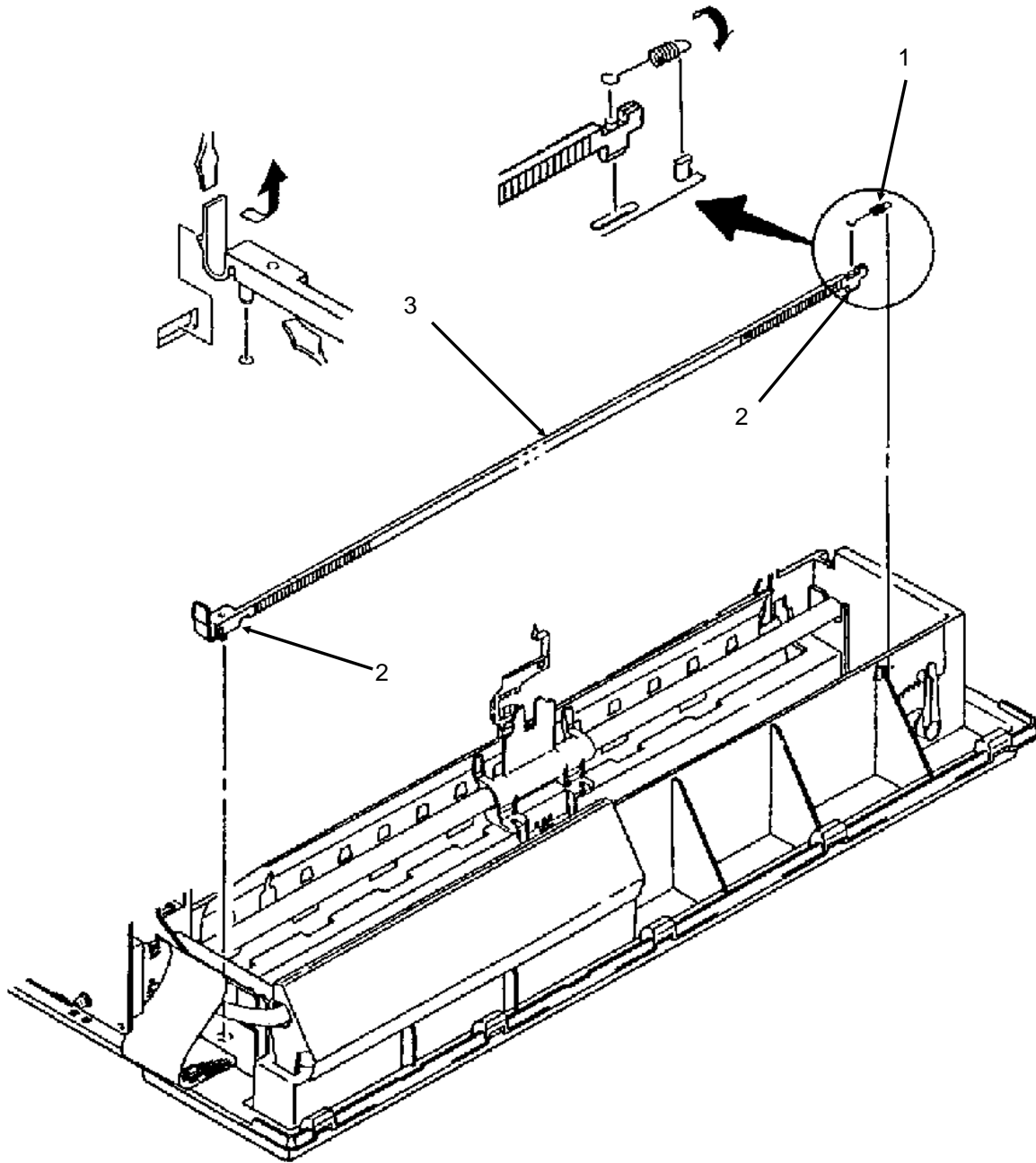

3-2-13.pcx

3.2.14 Roller/Holder Backup Assembly

1. Perform these procedures: 3.2.01, 3.2.02, 3.2.04, and 3.2.11.
2. Use a small straight slot screwdriver to disengage the claws of the backup roller holder spring (1) from the carriage frame (2).
3. Remove the roller/holder backup assembly (3).

NOTE:

The roller/holder backup assembly includes the backup roller (4), the backup roller holder (5), and the pin (6).

<input type="checkbox"/>	P/N 53343201	Assembly: Roller/Holder Backup		Both	B.2.06
<input type="checkbox"/>	P/N 53341701	Roller: Back Up	RSPL	Both	B.2.06
<input type="checkbox"/>	P/N 53341801	Holder: Back Up Roller	RSPL	Both	B.2.06
<input type="checkbox"/>	P/N N/A	Pin		Both	B.2.06
<input type="checkbox"/>	P/N N/A	Backup Roller Holder Spring		Both	B.2.06

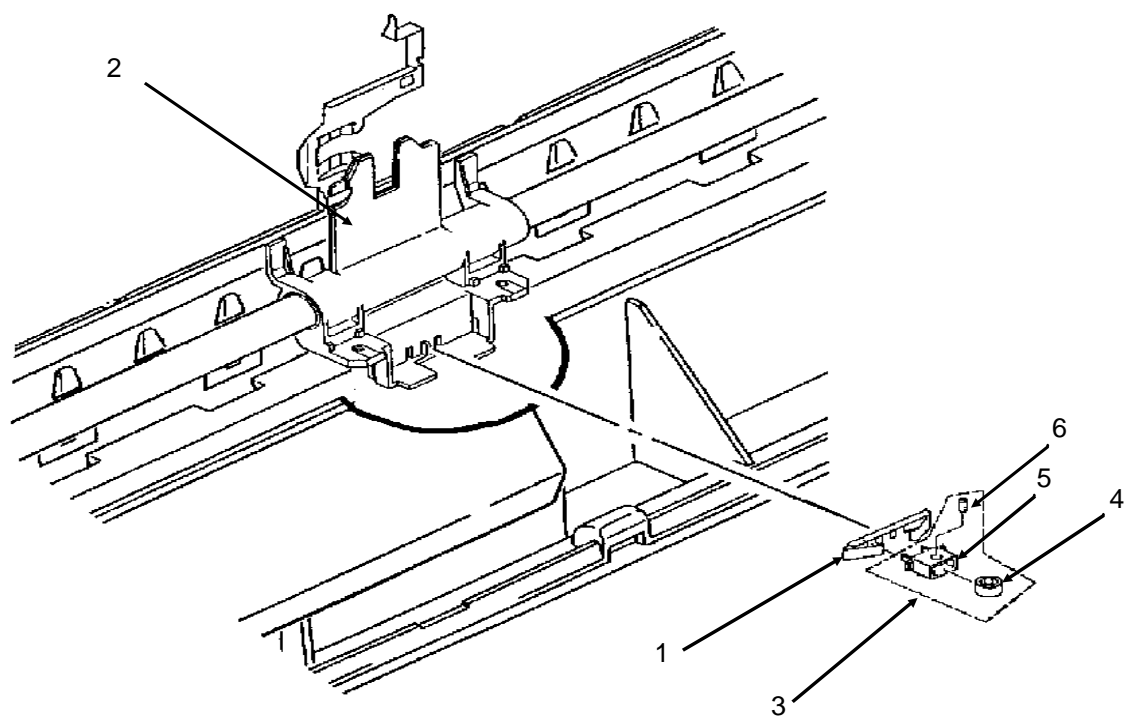

3-2-14.pcx

3.2.15 Guide Rail and Adjust Cam

1. Perform these procedures: 3.2.01, 3.2.02, 3.2.04, 3.2.11, and 3.2.14.
2. Rotate the adjust cam (1) in the direction of arrow A as far as possible.
3. Pull the cam out and remove it.
4. Carefully press the claw (2 *location only*) in the base frame down to release the guide rail (3). Do not press too hard or the claw will break.
5. Use a straight slot screwdriver to slide the guide rail in direction of arrow A.
6. Lift the guide at position B and work the other end of the guide free to remove the guide rail.
7. Remove the ground clip (4)

NOTE:

Installation

After installing the guide rail, check the printhead gap adjustment. Refer to Section 3.3 of this Service Handbook.

<input type="checkbox"/>	P/N 51009701	Guide: Rail Ground Clip	RSPL	Both	B.2.03
<input type="checkbox"/>	P/N 51009801	Guide: Rail (Narrow)	RSPL	590	B.2.03
<input type="checkbox"/>	P/N 51009901	Guide: Rail (Wide)	RSPL	591	B.2.03
<input type="checkbox"/>	P/N 53067701	Cam: Adjust	RSPL	Both	B.2.03

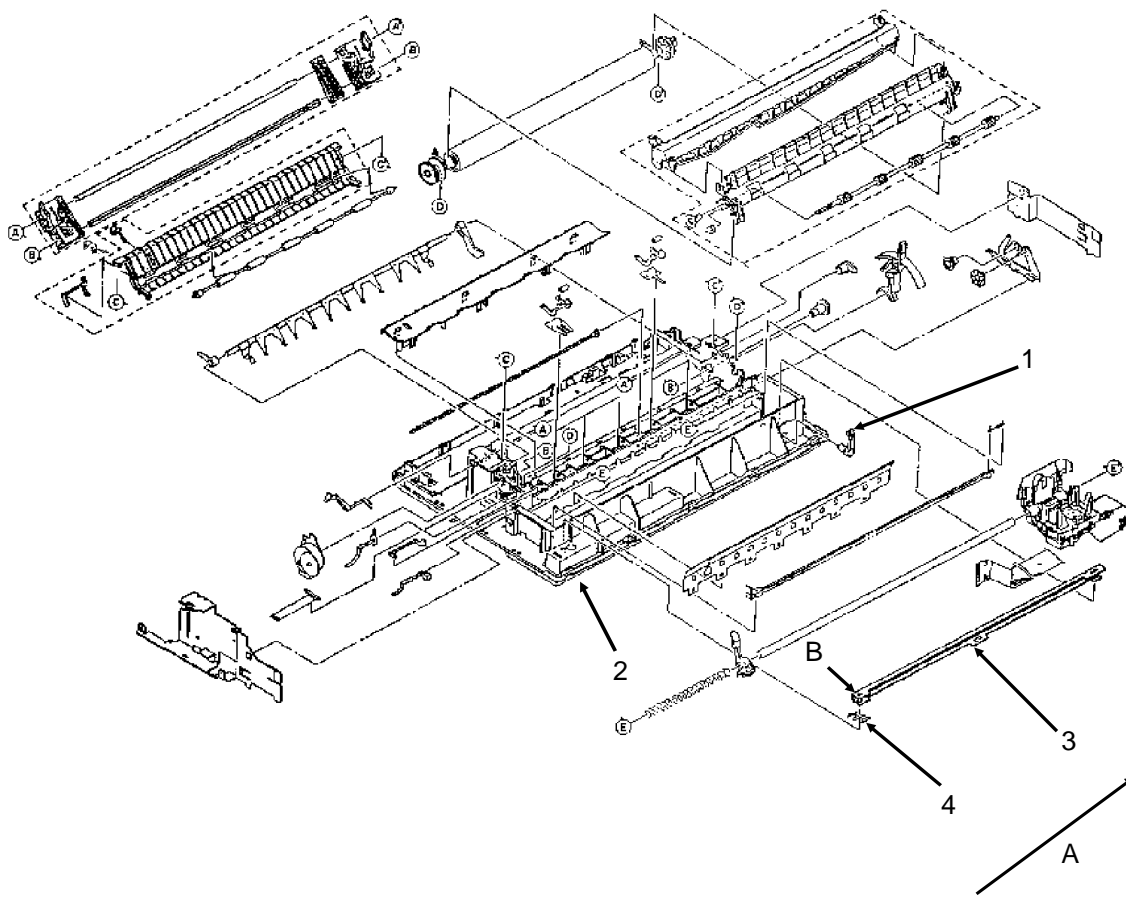

3-2-15.pcx

3.2.16 Left Ground Plate

1. Perform these procedures: 3.2.01, 3.2.06, and 3.2.07.
2. Cut the nylon tie and release the cable. (Not shown).
3. Work the left ground plate (1) up, and then out, to remove it.

P/N 51010301 Plate: Left Ground RSPL Both B.2.03

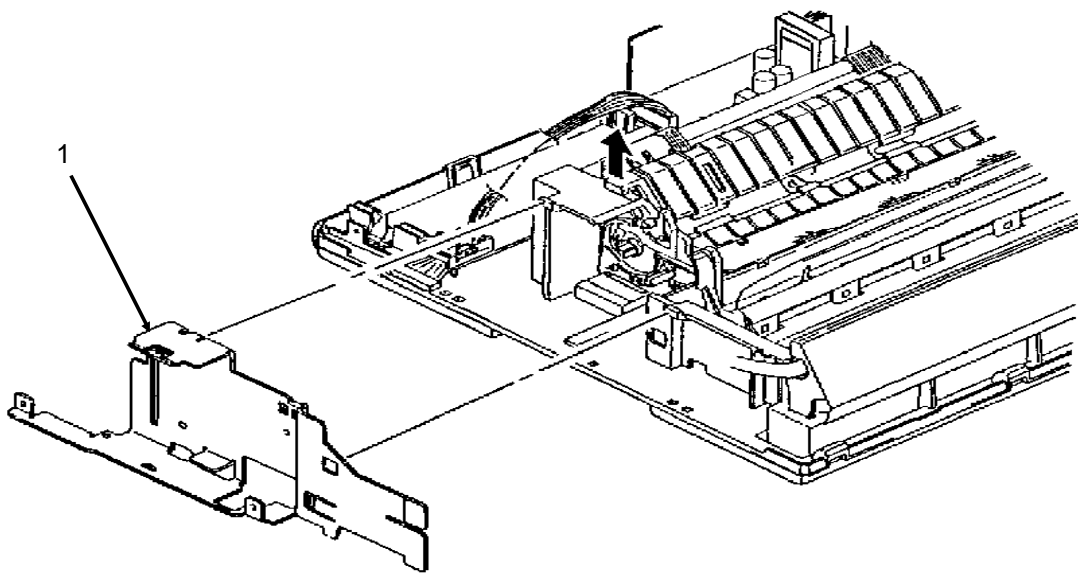

3-2-16.pcx

3.2.17 Right Ground Plate

1. Perform these procedures: 3.2.01, and 3.2.06.
2. Pull the top tabs (1) of the right ground plate (2) out to free the plate from the claws of the base frame. You may have to use a screwdriver to work the plate tabs free.
3. Lift the plate and remove it.

NOTE:

Installation

The plate must be securely seated under the claws.

P/N 51010201 Plate: Right Ground RSPL Both B.2.04

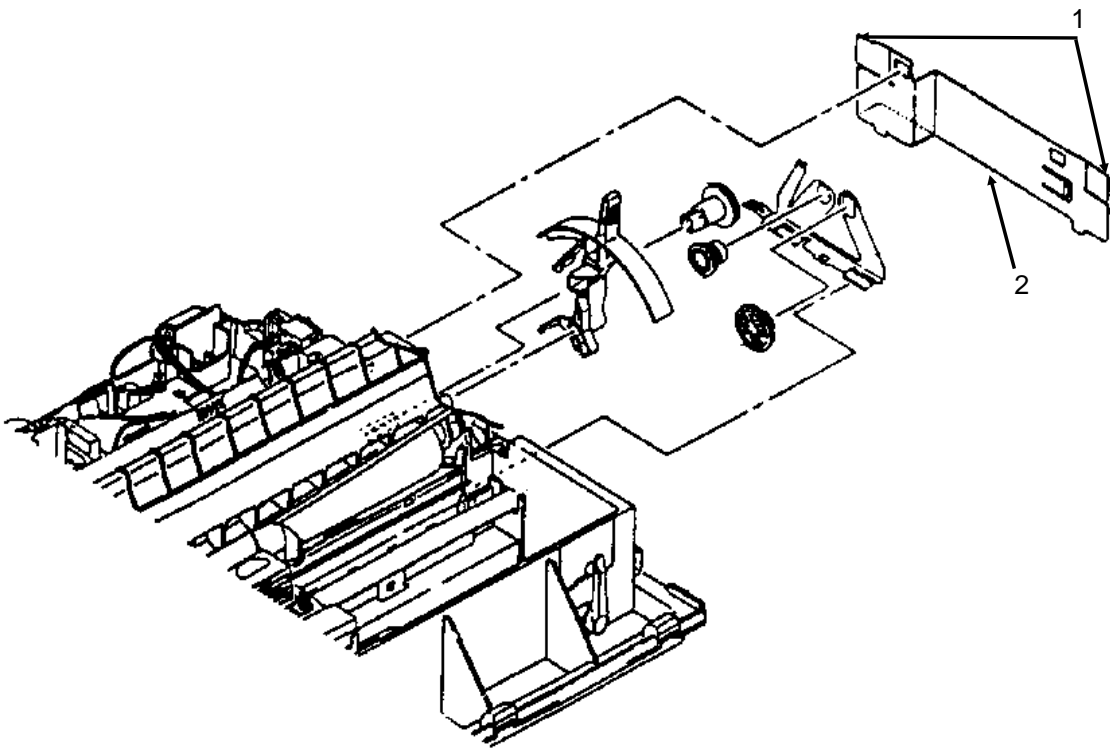

3-2-17.pcx

3.2.18 Rear and Cut Sheet Paper Feed Sensor Levers

1. Perform these procedures: 3.2.01, 3.2.06, 3.2.07, and 3.2.16.
2. Turn the cut sheet/continuous feed paper sensor lever (1) until the flag is at the top, then work the lever free.
3. Remove the lever.
4. Turn the rear feed paper sensor lever (2) until the flag is at the top, then work the lever free.
5. Remove the lever.

<input type="checkbox"/>	P/N 50804902	Lever: Sensor Cut Sheet/Continuous	RSPL	Both	B.2.03
<input type="checkbox"/>	P/N 50804801	Lever: Rear Sensor	RSPL	Both	B.2.03

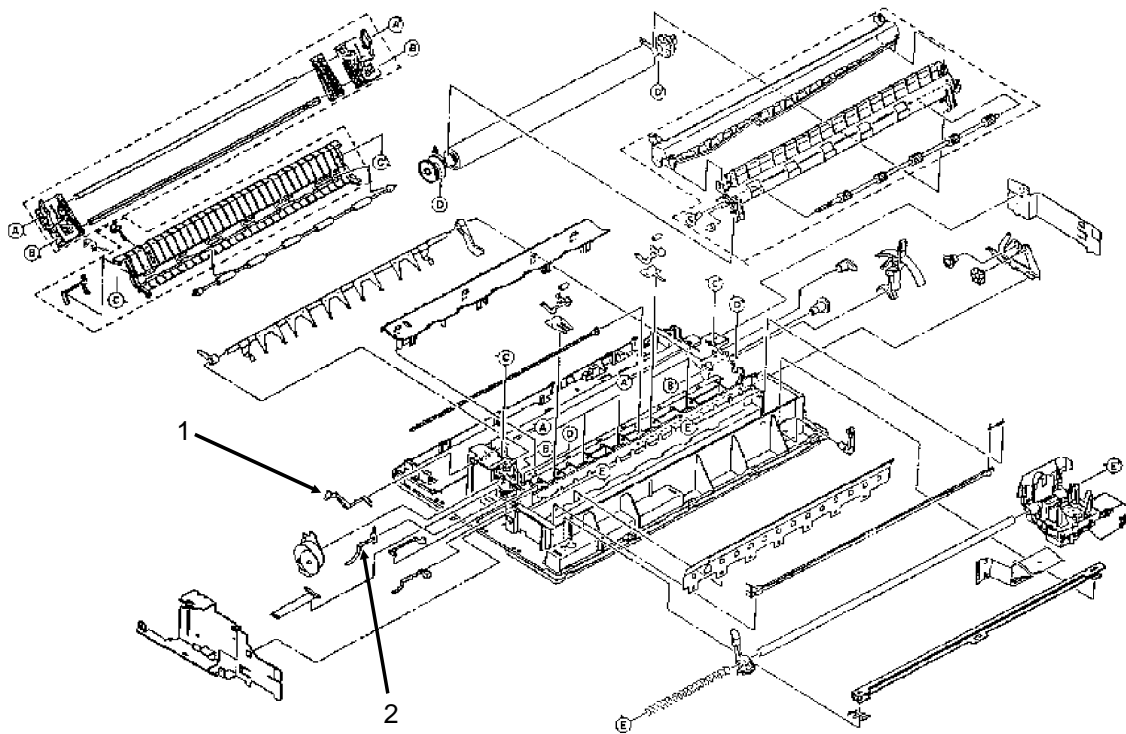

3-2-15.pcx

3.2.19 Platen Assembly

1. Perform these procedures: 3.2.01, and 3.2.06.
2. Move the change lever (1) to the bottom feed position (to the rear of the printer).
3. Push the lock levers (2) in, then rotate them towards the front to unlock them from the frame.
4. The levers should be vertical.
5. Lift the platen assembly (3) straight up and remove it.

NOTE:

Installation

After installing the platen assembly, check the printhead gap adjustment. Refer to Section 3.3 of this Service Handbook.

Cleaning

When cleaning, refer to Section 3.4 of this Service Handbook.

Lubrication

When lubricating, refer to Section 3.5 of this Service Handbook.

<input type="checkbox"/>	P/N 50098301	Platen Assembly (Narrow)	RSPL	590	B.2.04
<input type="checkbox"/>	P/N 50098302	Platen Assembly (Wide)	RSPL	591	B.2.04

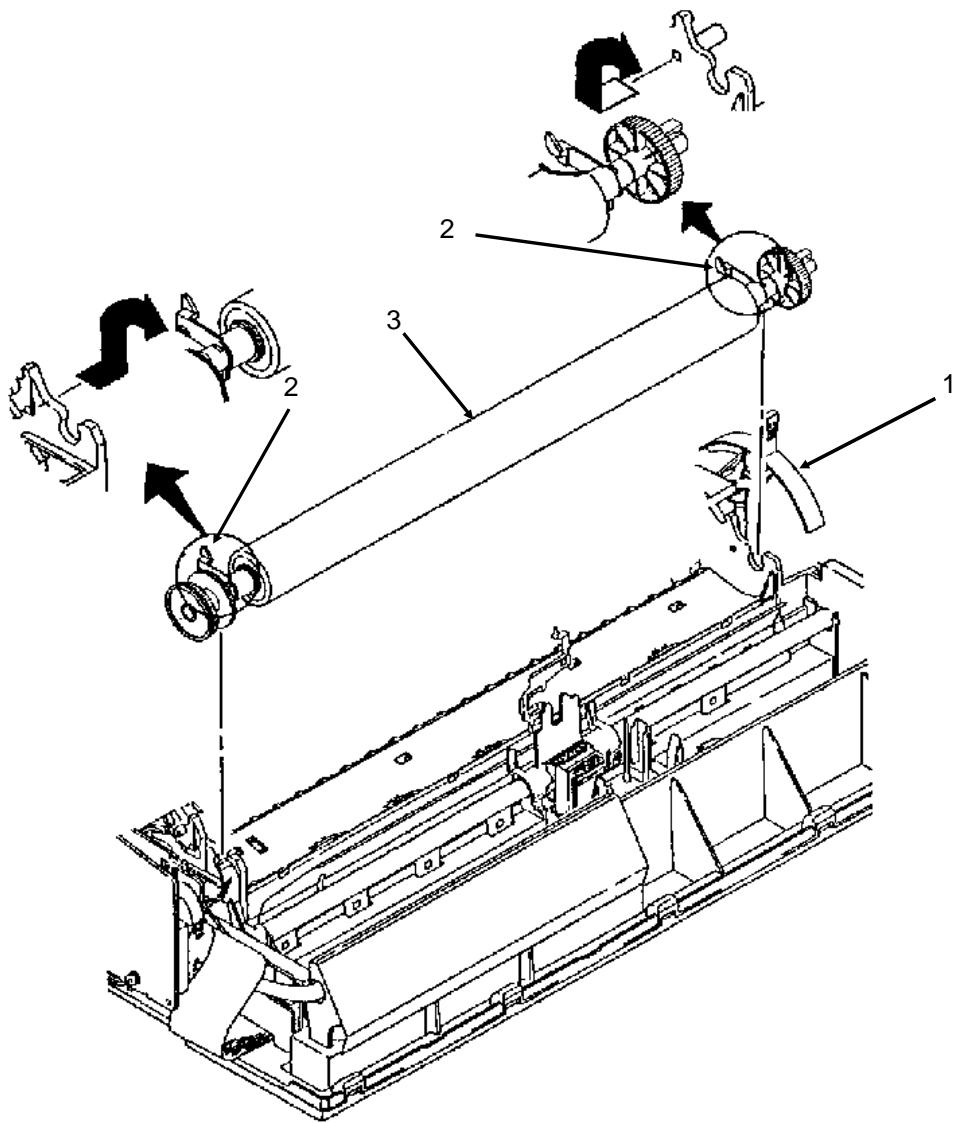

3-2-19.pcx

3.2.20 Paper Chute Assembly

1. Perform these procedures: 3.2.01, 3.2.06, and 3.2.19.
2. Remove the rear pressure roller (1).
3. Use a straight slot screwdriver to release the claws of the lock spring (2) and remove the spring.
4. Remove the paper chute assembly (3).

NOTE:

The paper chute assembly includes the levers for the rear and top paper feed paths.

<input type="checkbox"/>	P/N 53341301	Roller: Pressure Rear (Narrow)	RSPL	590	B.2.05
<input type="checkbox"/>	P/N 53341401	Roller: Pressure Rear (Wide)	RSPL	591	B.2.05
<input type="checkbox"/>	P/N 50924701	Spring: Lock	RSPL	Both	B.2.05
<input type="checkbox"/>	P/N 50097701	Paper Chute Assembly N	RSPL	590	B.2.05
<input type="checkbox"/>	P/N 50097801	Paper Chute Assembly W	RSPL	591	B.2.05

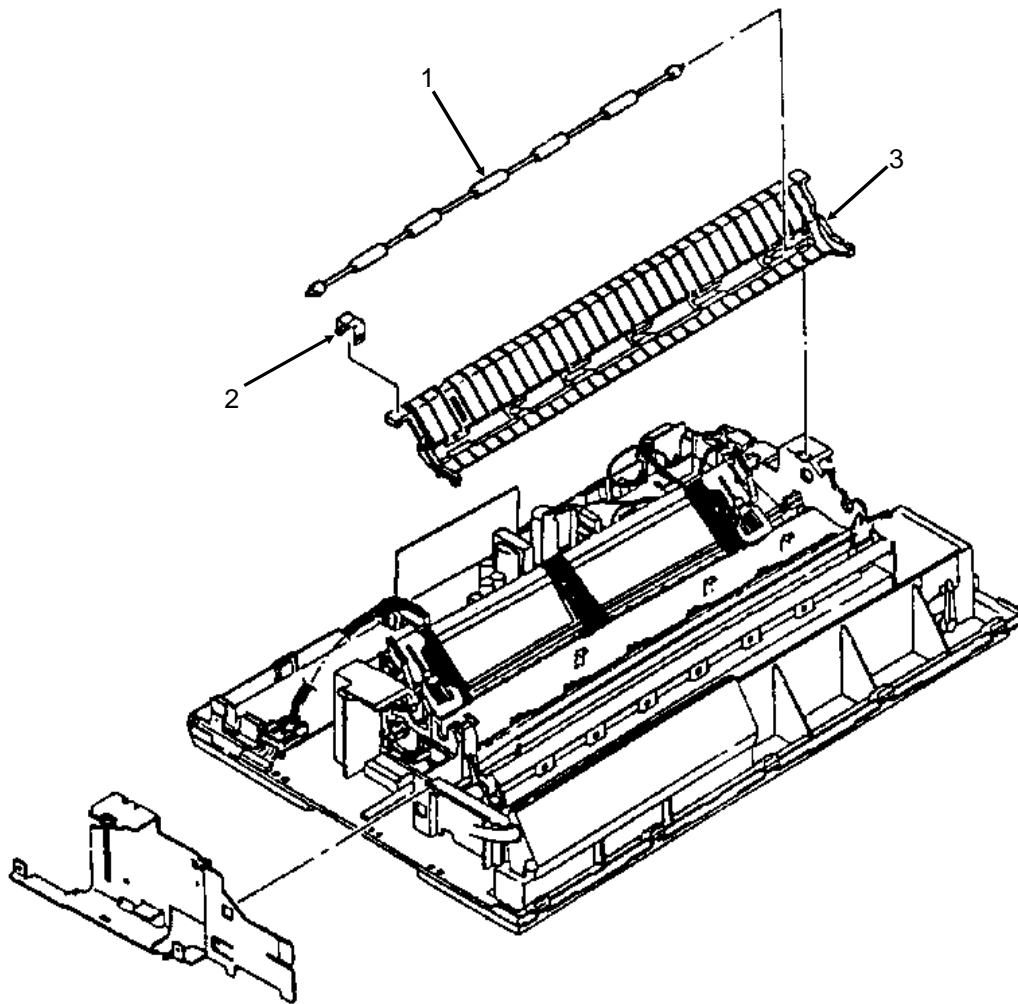

3-2-15.pcx

3.2.21 Line Feed Motor Assembly

1. Perform these procedures: 3.2.01, 3.2.06, 3.2.07, 3.2.16, 3.2.20, and 3.2.21.
2. Firmly press down on the line feed motor assembly (1) while tilting the assembly out.
3. Remove the line feed motor assembly.
4. Remove the line feed connection cord (2).

CAUTION:

The line feed idle gear (3) should be removed only if it must be replaced. The claws will break when the gear is removed. A new gear must be installed.

<input type="checkbox"/>	P/N 51228401	Gear: Line Feed Idle	RSPL	Both	B.2.03
<input type="checkbox"/>	P/N 56510301	Motor: Line Feed (Assembly)	RSPL	Both	B.2.03
<input type="checkbox"/>	P/N 56627201	Cord: Connection Line Feed	RSPL	Both	B.2.03

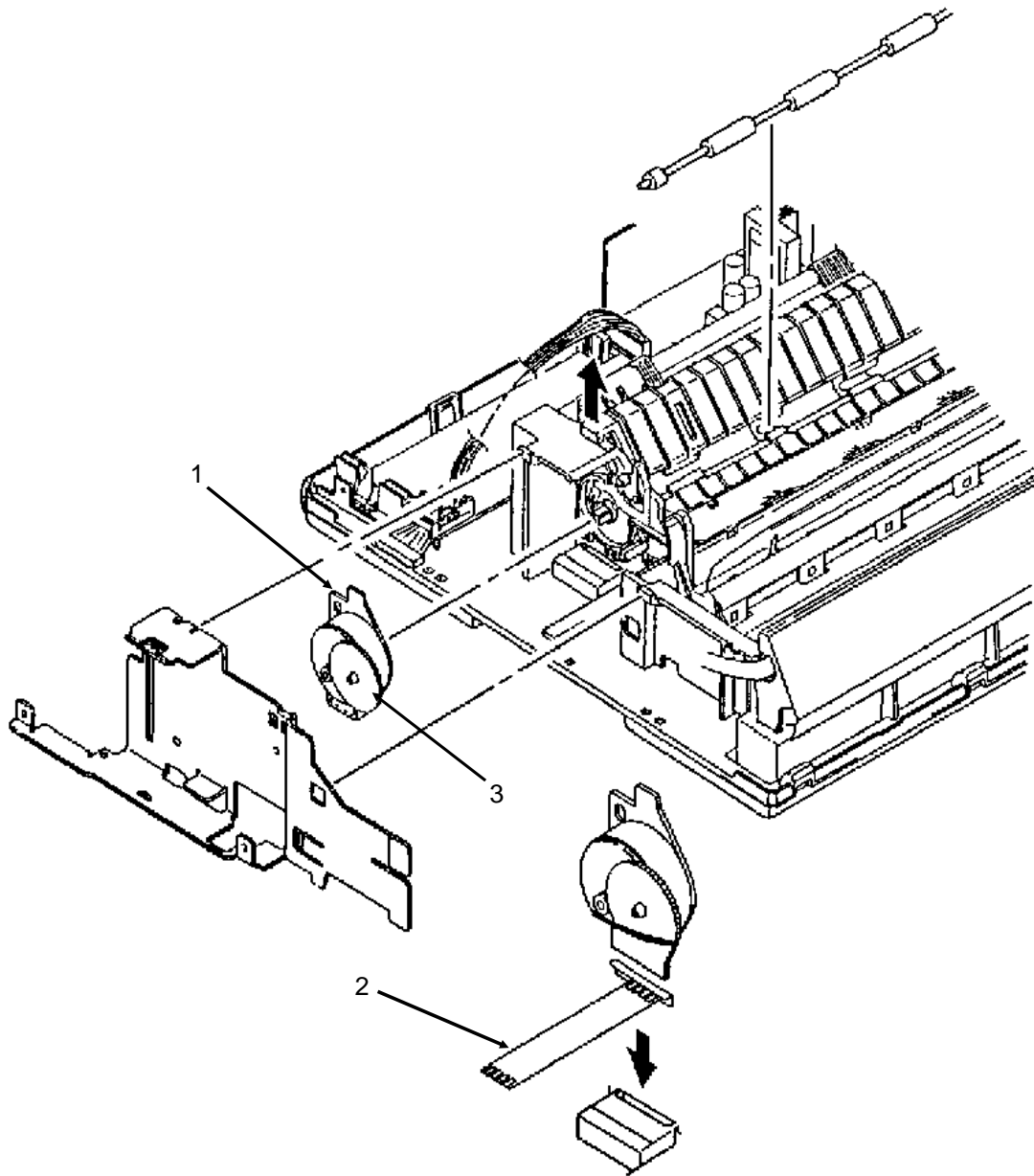

3-2-21.pcx

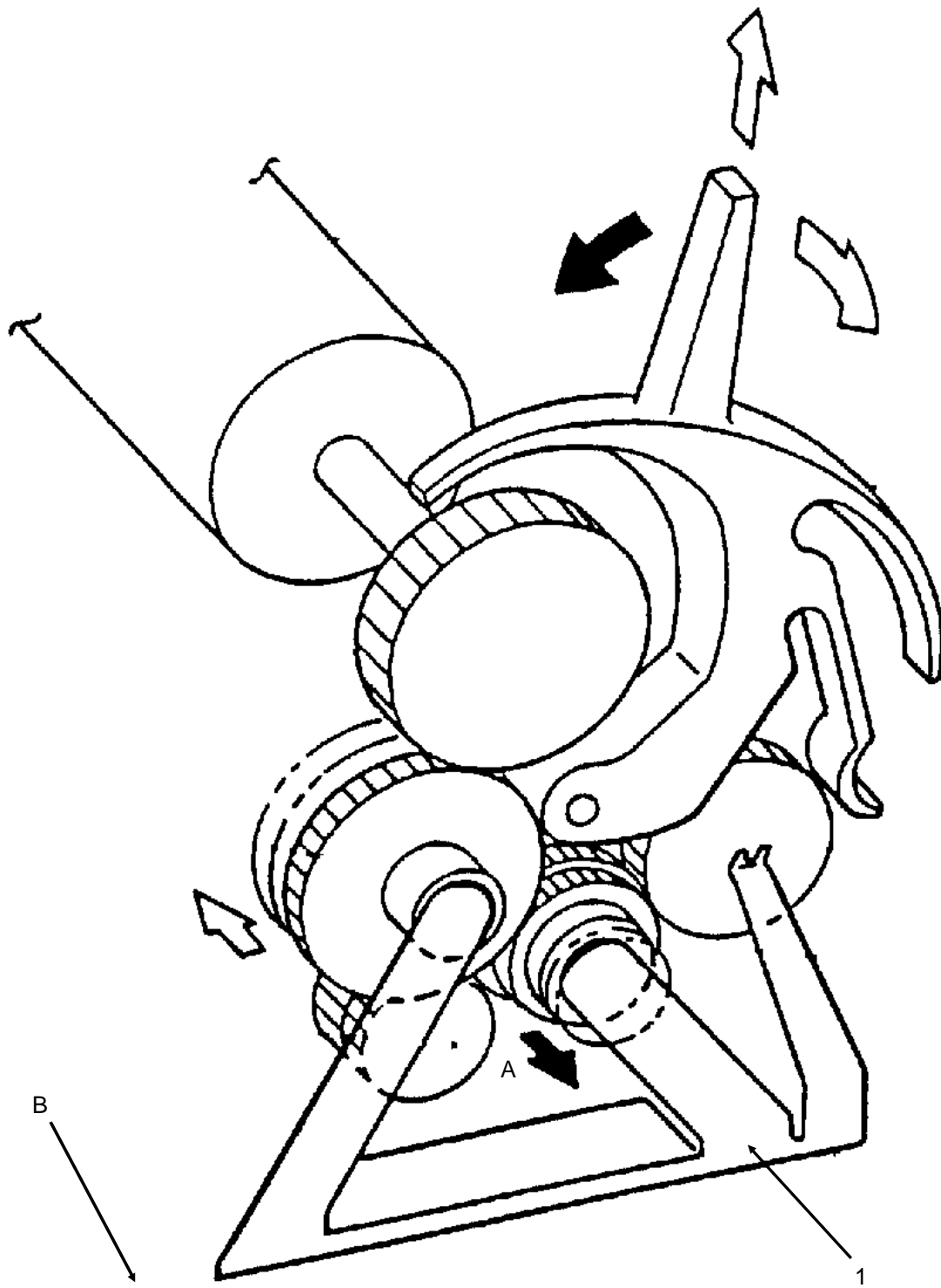

3-2-22.pcx

3.2.23 Idle Gear and Change Lever

1. Perform these procedures: 3.2.01, 3.2.06, 3.2.07, 3.2.16, 3.2.17, 3.2.19, 3.2.20, and 3.2.22.
2. Remove the idle gear (1). The idle gear is a large narrow gear.
3. Release the claw (2) of the change lever (3). The claw is accessed from inside the unit.
4. Remove the change lever.

NOTE:

Lubrication

When lubricating, refer to Section 3.5 of this Service Handbook.

<input type="checkbox"/>	P/N 50805101	Lever: Change	RSPL	Both	B.2.04
<input type="checkbox"/>	P/N 51228201	Gear: Idle	RSPL	Both	B.2.04

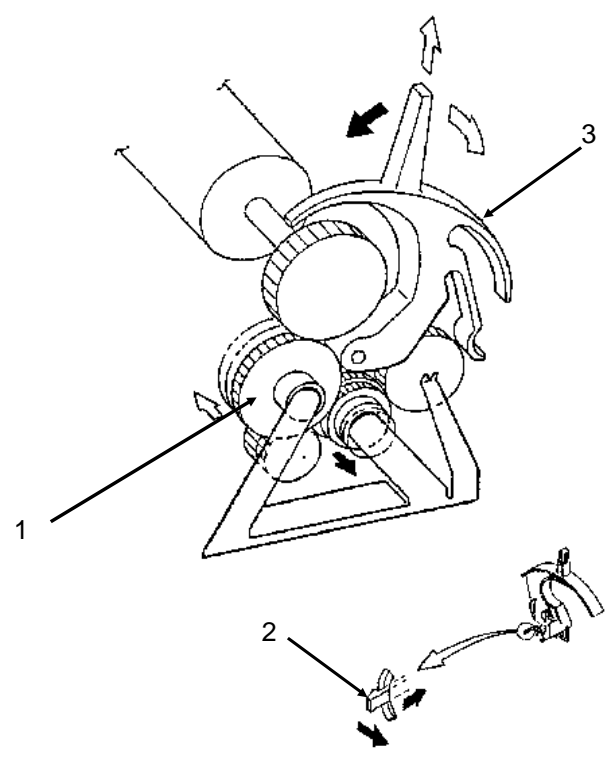
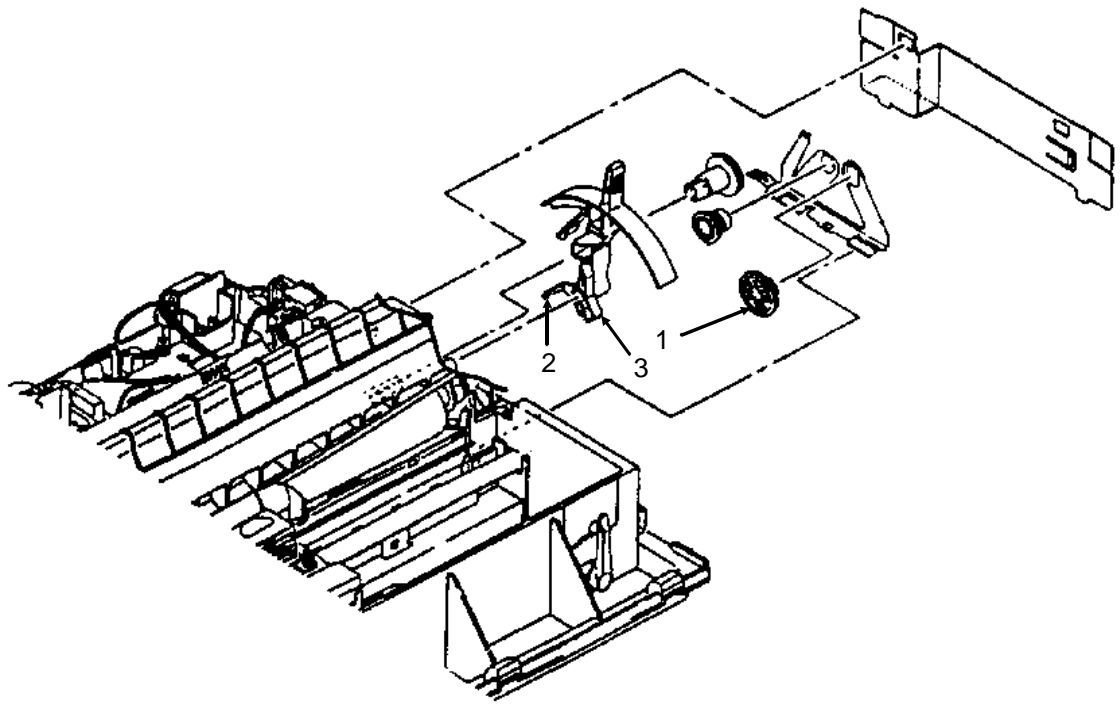

3-2-23.pcx

3.2.24 Pressure Spring

1. Perform these procedures: 3.2.01, 3.2.06, 3.2.07, 3.2.16, 3.2.17, 3.2.19, 3.2.20, 3.2.22, and 3.2.23.
2. Turn the front release gear arm (1) until it is disengaged.
3. Remove the release cam (2). This is the medium size, thick cam.
4. Work the end of the pressure spring (3) free and remove the spring.
5. Remove the front release gear arm. This arm is long, with a serrated edge.
6. Remove the switch lever (4). This is the small lever.

NOTE:

Installation

Install the release cam first.

Then install one end of the pressure spring into the release cam.

Slide the cam and spring away from the base frame until the opposite end of the spring can be installed into the frame.

Make sure that the front release gear arm is engaged as shown (A).

Lubrication

When lubricating, refer to Section 3.5 of this Service Handbook.

<input type="checkbox"/>	P/N 50805201	Lever: Switch	RSPL	Both	B.2.05
<input type="checkbox"/>	P/N 50805301	Cam: Release	RSPL	Both	B.2.04
<input type="checkbox"/>	P/N 50923301	Spring: Pressure (Narrow)	RSPL	590	B.2.05
<input type="checkbox"/>	P/N 50923401	Spring: Pressure (Wide)	RSPL	591	B.2.05
<input type="checkbox"/>	P/N 51228301	Arm: Front Release Gear	RSPL	Both	B.2.05

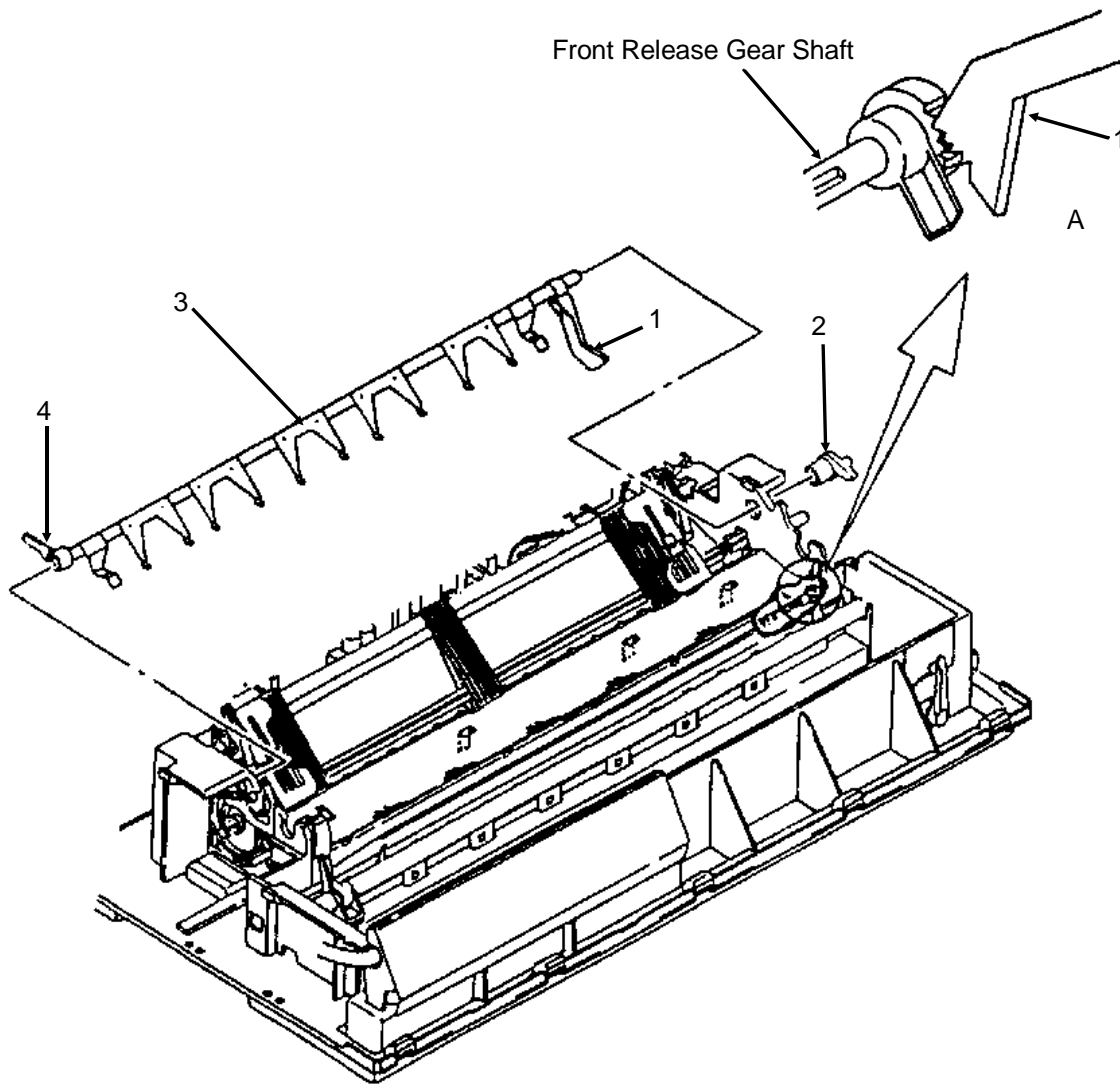

3-2-24.pcx

3.2.25 Carriage Shaft

CAUTION

The space motor assembly, etc. may be left in place when removing the carriage shaft. However, use extra care when doing so.

The carriage cable should be detached from the space motor before removing the carriage shaft.

1. Perform these procedures: 3.2.01, 3.2.06, 3.2.07, and 3.2.16.
2. Push the end (A) of the carriage shaft (1) until it clears the base frame.
3. Pull the carriage shaft free of the base frame.
4. Remove the support protect reset spring (2).
5. Remove the support protector assembly (3).
6. Remove the frame set carriage (4).

NOTE:

Installation

After installing the carriage shaft, check the printhead gap adjustment. Refer to Section 3.3 of this Service Handbook.

Cleaning

When cleaning, refer to Section 3.4 of this Service Handbook.

Lubrication

When lubricating, refer to Section 3.5 of this Service Handbook.

<input type="checkbox"/>	P/N 50098901	Carriage: Frame Set	RSPL	Both	B.2.06
<input type="checkbox"/>	P/N 50923601	Spring: Support Protect Reset	RSPL	Both	B.2.03
<input type="checkbox"/>	P/N 53067601	Protector: Support (Assembly)	RSPL	Both	B.2.03
<input type="checkbox"/>	P/N 53563501	Shaft: Carriage (Narrow)	RSPL	590	B.2.03
<input type="checkbox"/>	P/N 53563502	Shaft: Carriage (Wide)	RSPL	591	B.2.03

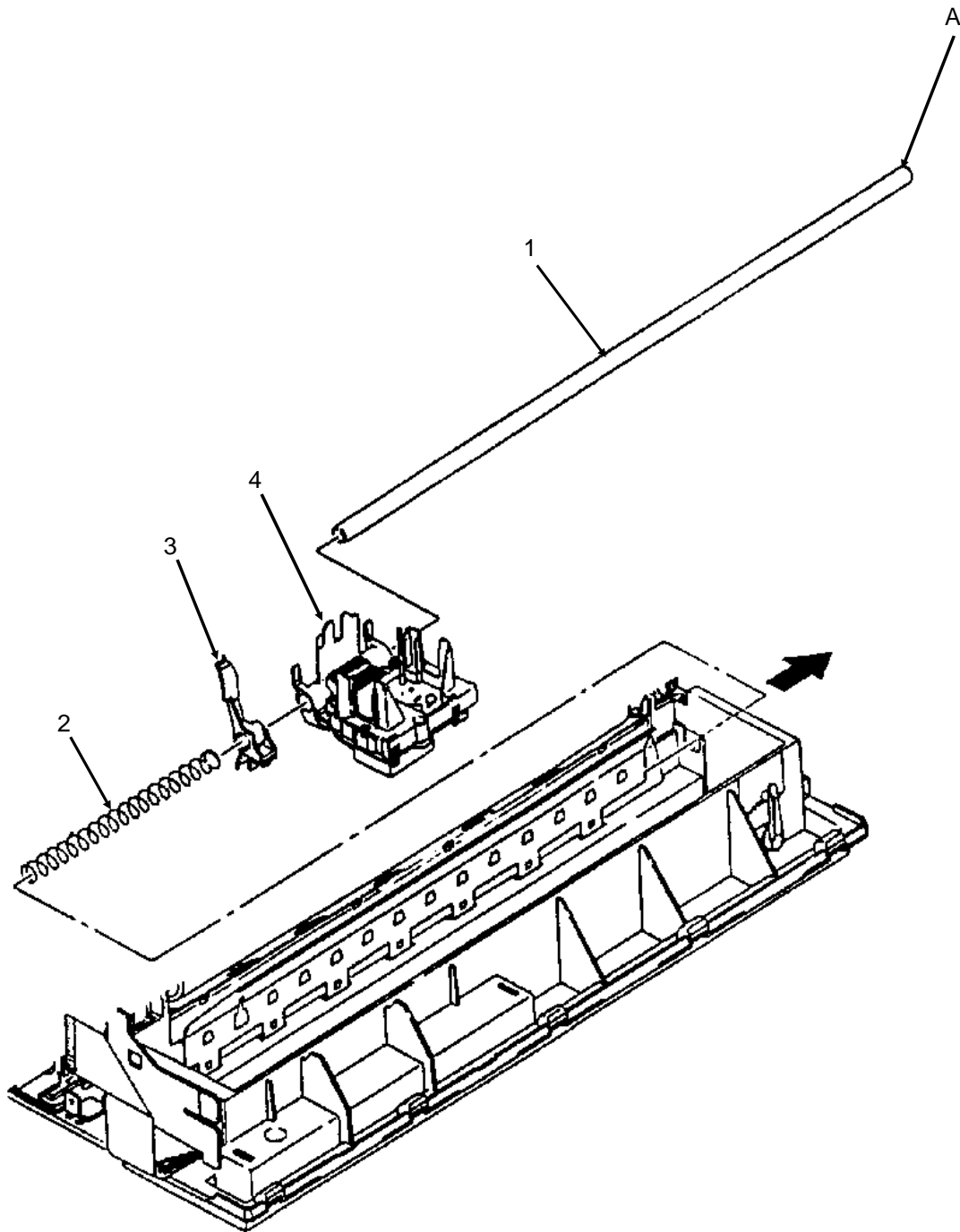

3-2-15.pcx

3.2.26 Leaf Spring

1. Perform these procedures: 3.2.01, 3.2.06, 3.2.07, 3.2.16, and 3.2.25.
2. Position the unit so you can access the top and bottom of the leaf spring (1).
3. Start at one end of the spring.
4. Use a straight slot screwdriver to release the bottom extension (2) from the claw of the base frame.
5. Pull the spring up to release the top of the spring from the upper claw.
6. Repeat the above two steps, working towards the opposite end of the spring.
7. Remove the spring.

<input type="checkbox"/>	P/N 50923001	Spring: Leaf (Narrow)	RSPL	590	B.2.03
<input type="checkbox"/>	P/N 50923101	Spring: Leaf (Wide)	RSPL	591	B.2.03

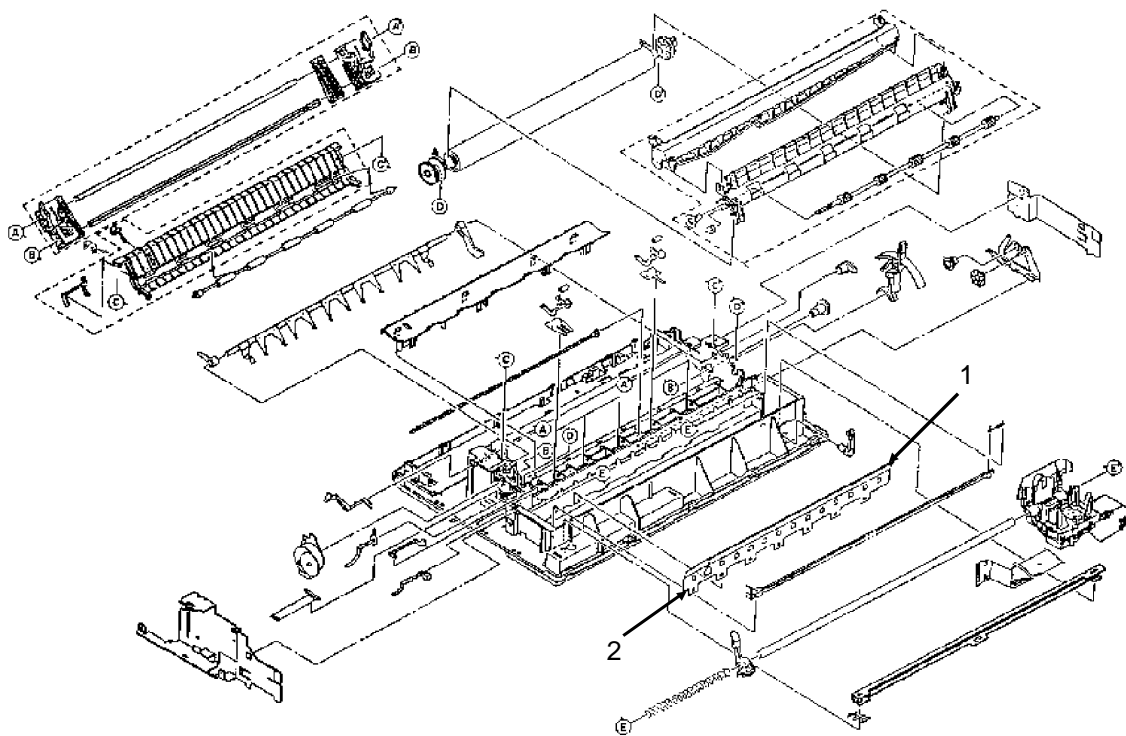

3-2-15.pcx

3.2.27 Bottom Paper Sensor Levers

1. Perform these procedures: 3.2.01, 3.2.06, 3.2.07, 3.2.16, 3.2.17, 3.2.19, 3.2.20, 3.2.22, 3.2.23, and 3.2.24.
2. Working from the underside of the unit, release the claws of the paper pan (1). When you release a claw, push on the claw to move the paper pan away from the main frame.
3. Remove the pan.
4. Rotate the bottom sensor lever (2) until the flag is at the top. Then, lift the lever and work it free of the frame to remove it. This lever has a box end.
5. Remove the bottom paper end lever (3).
6. Work the front release gear shaft (4) free of the tabs and remove it.

NOTE:

Lubrication

When lubricating, refer to Section 3.5 of this Service Handbook.

<input type="checkbox"/>	P/N 50097301	Pan: Paper (Narrow)	RSPL	590	B.2.05
<input type="checkbox"/>	P/N 50097401	Pan: Paper (Wide)	RSPL	591	B.2.05
<input type="checkbox"/>	P/N 50804601	Lever: Bottom Paper End	RSPL	Both	B.2.03
<input type="checkbox"/>	P/N 50804701	Lever: Bottom Sensor	RSPL	Both	B.2.03
<input type="checkbox"/>	P/N 51227801	Shaft: Front Release Gear (Narrow)	RSPL	590	B.2.05
<input type="checkbox"/>	P/N 51227901	Shaft: Front Release Gear (Wide)	RSPL	591	B.2.05

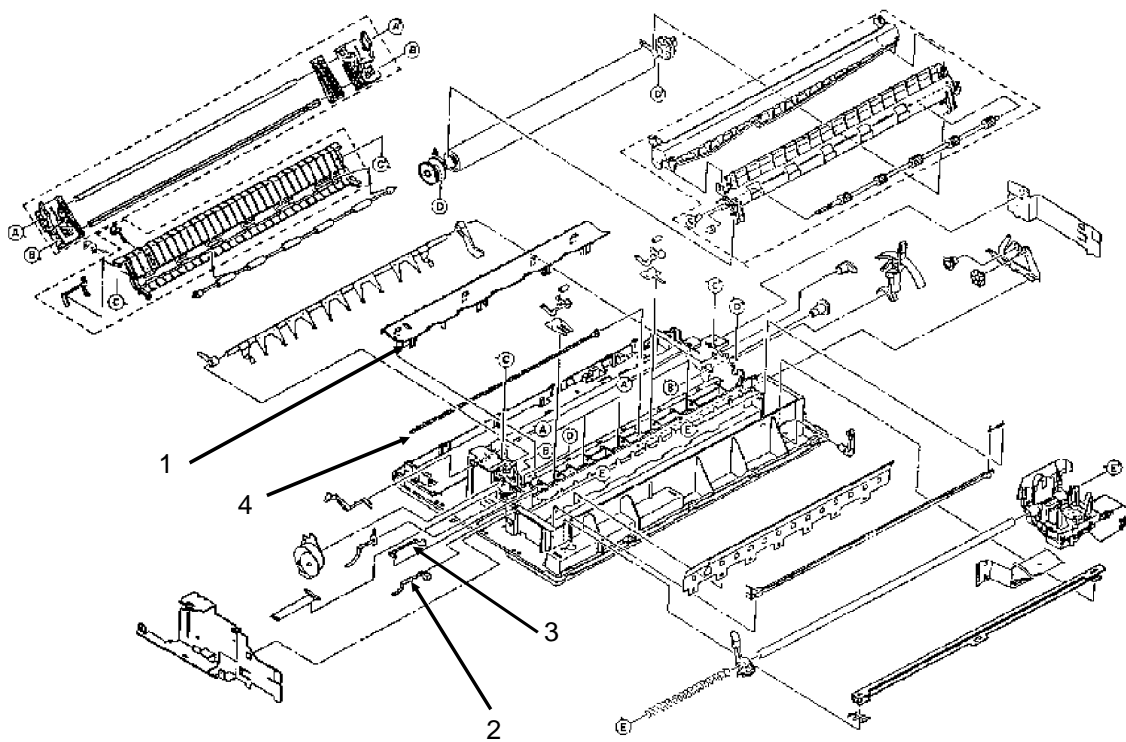

3-2-15.pcx

3.2.28 Front Pressure Roller Assembly

1. Perform these procedures: 3.2.01, 3.2.06, 3.2.07, 3.2.16, 3.2.17, 3.2.19, 3.2.20, 3.2.22, 3.2.23, and 3.2.24, 3.2.27.
2. Separate the arms of the front roller holders (1) and remove the front pressure roller (2).
3. Squeeze the extensions of the front roller holders together and remove the holders.
4. Lift and remove the front pressure springs (3A and 3B).

NOTE:

The front pressure springs for the Microline 590 (3A) have three extensions. The front pressure springs for the Microline 591 (3B) have one extension. The Microline 591 uses both springs.

Lubrication

When lubricating, refer to Section 3.5 of this Service Handbook.

<input type="checkbox"/>	P/N 50922901	Spring: Front Pressure (Narrow)	RSPL	590	B.2.05
<input type="checkbox"/>	P/N 50922801	Spring: Front Pressure (Wide)	RSPL	591	B.2.05
<input type="checkbox"/>	P/N 53341101	Holder: Front Roller	RSPL	Both	B.2.05
<input type="checkbox"/>	P/N 53341202	Roller: Front Pressure	RSPL	Both	B.2.05

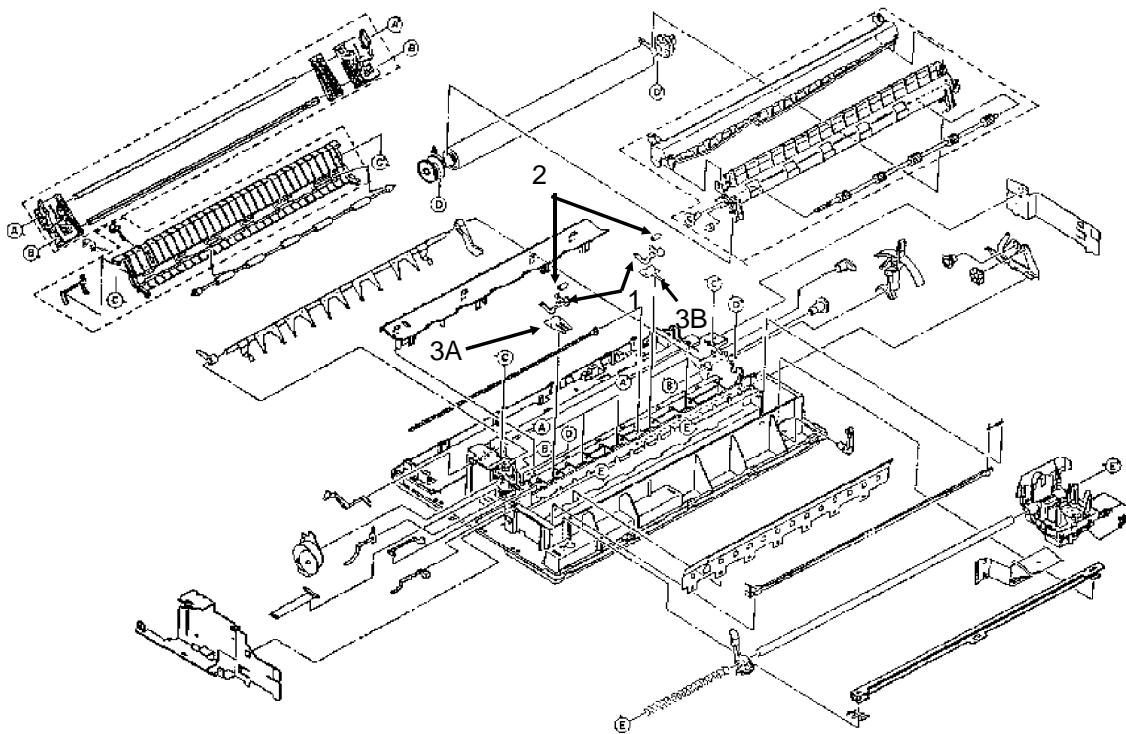

3-2-15.pcx

3.2.29 Tractor Assembly

1. Perform these procedures: 3.2.01, 3.2.06, 3.2.07, 3.2.16, 3.2.17, 3.2.19, 3.2.20, 3.2.22, 3.2.23, and 3.2.24.
2. Use a needle nose pliers to release the claw of the tractor gear (1) and remove the gear.
3. Remove the change gear (2).
4. Raise the lock levers (3) on the left (4) and right (5) tractor assemblies.
5. Slide the lower tractor feed shaft (6) in the direction of arrow A and remove the shaft. This shaft is square.
6. Slide the upper tractor feed shaft (7) in the direction of arrow A and remove the shaft. This shaft is round.
7. Remove the left tractor assembly, the guide (8), and the right tractor assembly.

NOTE:

Installation

The tractors must be synchronized. Align the synchronization marks (9) in the same direction.

Verify that the guide holes (10) in the tractor drive gears are facing the same direction.

The left tractor assembly must be positioned to the left (line feed motor side) of the plastic tab and ground plate.

Lubrication

When lubricating, refer to Section 3.5 of this Service Handbook.

<input type="checkbox"/>	P/N 50097501	Tractor: Assembly (Narrow)	RSPL	590	B.2.05
<input type="checkbox"/>	P/N 50097502	Tractor: Assembly (Wide)	RSPL	591	B.2.05
<input type="checkbox"/>	P/N 51228001	Gear: Change	RSPL	Both	B.2.04
<input type="checkbox"/>	P/N 51228101	Gear: Tractor	RSPL	Both	B.2.04

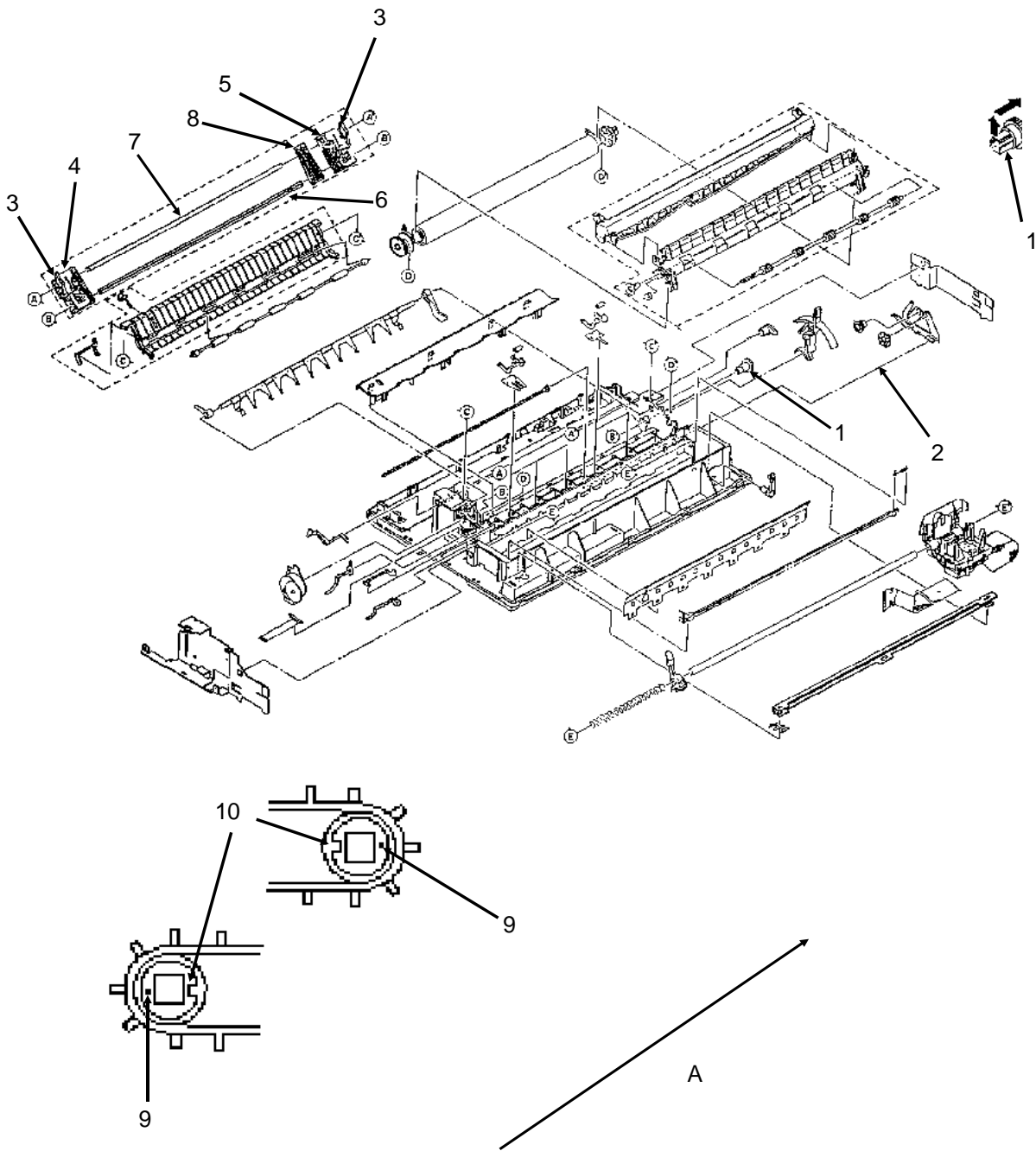

3-2-29.pcx

3.2.30 Main Frame

1. All disassembly procedures must be carried out to reach the base frame (1).

<input type="checkbox"/>	P/N 53563101	Frame: Main (Narrow)	RSPL	590	B.2.03/4/5
<input type="checkbox"/>	P/N 53563201	Frame: Main (Wide)	RSPL	591	B.2.03/4/5

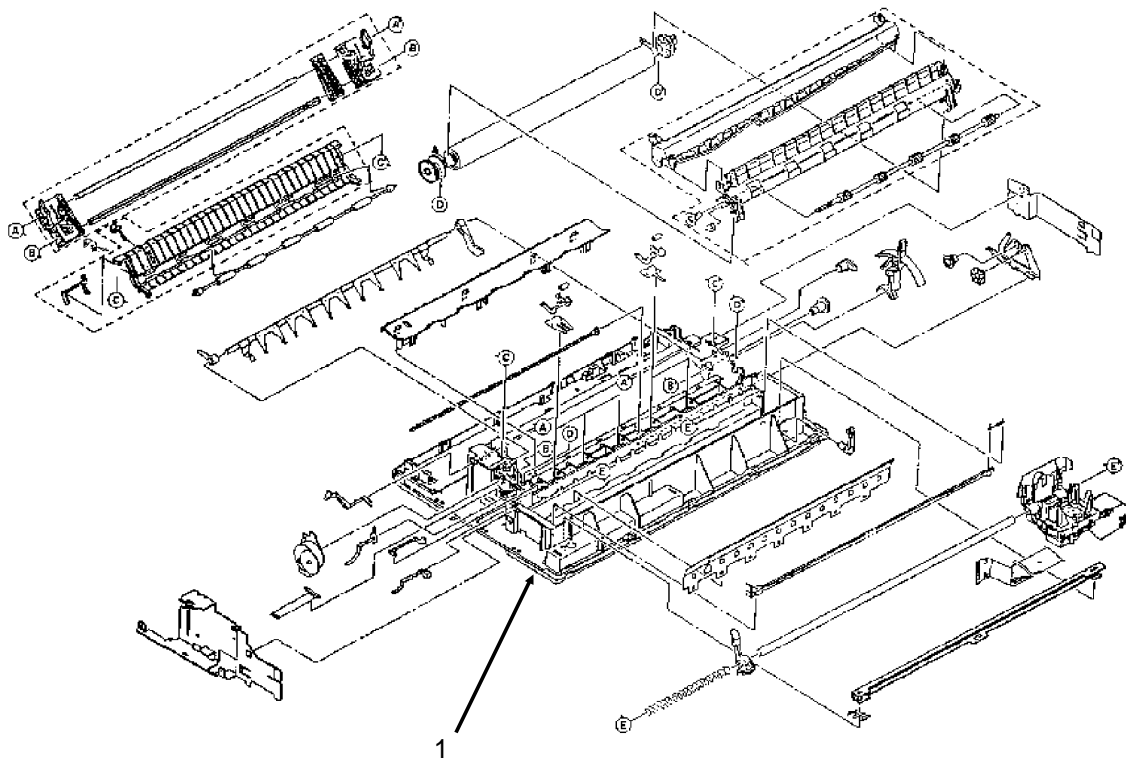

3-2-15.pcx

This page was intentionally left blank.

3.3 PRINTER ADJUSTMENTS

3.3.01 General Information

This section contains the procedures for performing adjustments on the printer. These procedures may be required when replacing either consumables or parts. The disassembly/assembly procedures list the required adjustments and refer you to this section. Failure to perform these procedures may result in unnecessary service calls.

3.3.02 Printhead Gap Adjustment

General Information

Before performing this adjustment, always verify that the printhead is properly installed. This adjustment should be performed when the following parts are replaced.

1. Printhead (3.2.02)
2. Space Motor Assembly (3.2.11)
3. Space Rack (3.2.13)
4. Guide Rail (3.2.15)
5. Platen Assembly (3.2.19)
6. Carriage Shaft (3.2.25)

NOTE:

Place a new ribbon cartridge in the printer before testing for parallelism.

If the density of the top portion of the characters differ from that of the bottom portion, follow steps 10 - 12.

This adjustment is comprised of four phases.

1. Setup Phase

Steps 1-6

The cover is removed and the printhead is placed at a known reference point.

2. Printhead Gap Modification Phase

Steps 7 - 9

The distance between the printhead and the platen (at the left side of the platen) is modified by turning the adjust screw which varies the vertical position of the space motor.

3. Parallel Adjustment Phase

Steps 10 - 11

The adjust cam lever is moved to ensure the printhead moves parallel to the platen.

4. Recheck Phase

Steps 12 -13

Verifies that the parallel adjustment phase did not affect the printhead gap modification phase.

Procedure

Setup Phase

1. Remove the upper cover and pull roller assembly.
2. Move the change lever to the rear paper feed position.
3. Rotate the platen.
4. Set the gap change gear (Figure 1 A) to Range 2 by turning the adjust screw using a small phillips screwdriver. Turn this screw slowly while moving the carriage (1) to the left (if turning the screw counter clockwise) or (2) to the right (if turning the screw clockwise). This will allow easier rotation of the gears and prevent the gears from being stripped.

DO NOT DISENGAGE THE ADJUST GEAR!

Printhead Gap Modification Phase

5. Slide the carriage assembly to the left side of the platen.
6. Check the printhead gap. Use a 0.014 inch or 0.35 mm feeler gauge. The printhead gap must measure 0.014 +/- 0.001 inch (0.35 +/- 0.03 mm).
7. Use a large, straightened paper clip (Figure 1 B) to push down on the adjust gear. This will disengage the adjust gear from idle gear D.
8. Use a small phillips screwdriver to turn the adjust screw. (Figure 1 C)
Turning the screw **CLOCKWISE** will increase the printhead gap.
Turning the screw **COUNTERCLOCKWISE** will decrease the gap.
9. Slide the carriage assembly to the right side of the platen.

Parallel Adjustment Phase

10. Check the printhead gap at the right side of the platen.
11. If the gap measurements are different between the left and right positions, turn the adjust cam as follows. (Figure 2 B)
Turning the cam **CLOCKWISE** will increase the printhead gap.
Turning the cam **COUNTERCLOCKWISE** will decrease the printhead gap.

Recheck Phase

12. Check the printhead gap adjustment at the left, right, and center of the platen.
13. If the printhead gap is not the same at all three positions, return to step 6.

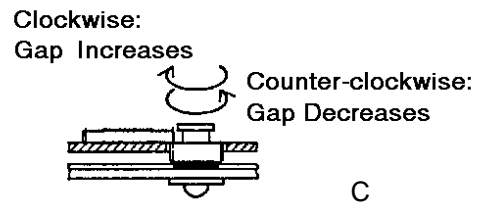
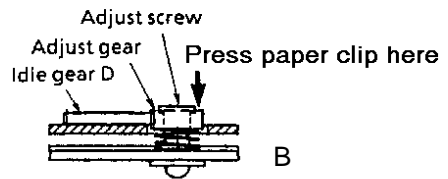
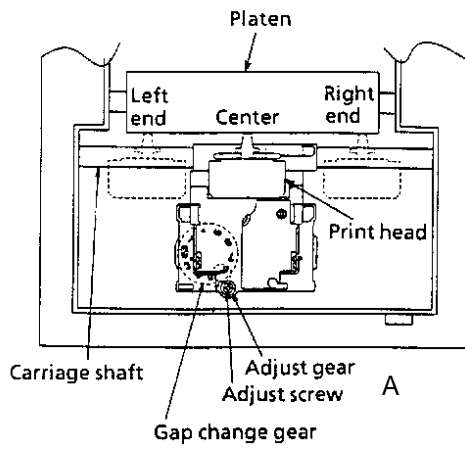

Figure 1

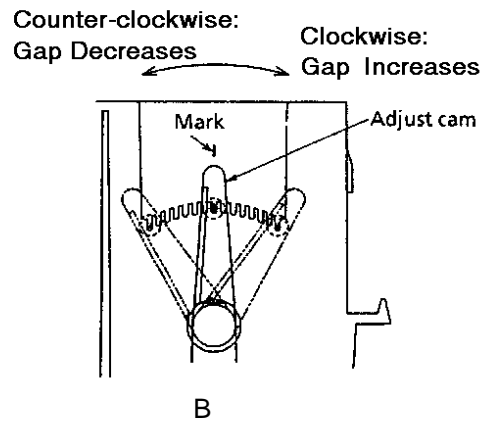
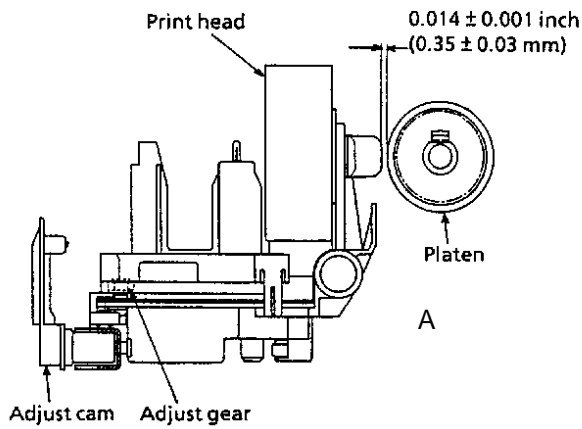

Figure 2

3-3-01a.tif

3.3.03 Key Combinations

Key Combinations	Description
SEL + LF (Hold during Power-ON)	Reset Menu to Factory Defaults.
SEL (Hold during Power-ON)	Access Menu (if Menu set to LIMITED OPERATION)
QUIET + FF/LOAD (Hold during Power-ON)	Reset Top of Form to Factory Default (1 inch)
QUIET (Hold during Power-ON)	Activate Rolling ASCII Test
LF (Hold during Power-ON)	Activate Font Test
SEL + FF/LOAD (Hold during Power-ON)	Activate Hexadecimal Dump Test

3.3.04 Menu Operation

General Information

The menu is used to customize the printer's settings and features.

The Menu is made up of a number of Groups.

Each Group has a list of Items.

Each Item has several Settings.

Menu Mode

To place the printer in the Menu Mode, follow this procedure.

1. Verify that continuous feed paper is installed.
2. Verify that the ribbon is correctly installed.
3. Verify that the width of the installed paper matches the paper width menu setting.

CAUTION:

If the Menu is set for wide paper, and narrow paper is used, the printhead will print on the platen. This could damage / destroy the printhead, platen, and ribbon.

4. Press and hold the SHIFT switch while pressing the SEL switch.
5. The MENU lamp will light. If the printer was selected, the SELECT lamp will light.
When in Menu Mode, the functions printed below the operator panel switches are active.
6. Press GROUP until the desired Group prints.
7. Press ITEM until the desired Item prints.
8. Press SET until the desired Setting prints.
9. Press EXIT to save the change and exit Menu Mode.

Printing the Menu

Printing the Menu provides a reference of current menu settings.

This will help you move through the menu.

Okidata **STRONGLY RECOMMENDS** printing the Menu *before* resetting the Menu to factory defaults.

Once the Menu is reset, all customized settings are LOST.

To print the Menu, follow this procedure.

1. Verify that continuous feed paper is installed.
2. Verify that the ribbon is correctly installed.
3. Verify that the width of the installed paper matches the paper width menu setting.

CAUTION:

If the Menu is set for wide paper, and narrow paper is used, the printhead will print on the platen. This could damage / destroy the printhead, platen, and ribbon.

4. Press and hold the SHIFT switch while pressing the SEL switch.
5. The MENU lamp will light. If the printer was selected, the SELECT lamp will light.
When in Menu Mode, the functions printed below the operator panel switches are active.
6. Press the PRINT switch.
7. The Menu will print.
8. Press EXIT to exit Menu Mode.

For more information regarding the menu, please refer to the Printer Handbook.

Sample Menu

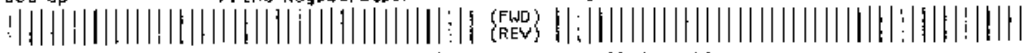
Printer Control	Emulation Mode	EPSON LQ
Font	Print Mode	LQ Courier
Font	Pitch	10 CPI
Font	Proportional Spacing	No
Font	Style	Normal
Font	Size	Single
Symbol Sets	Character Set	Set I
Symbol Sets	Language Set	American
Symbol Sets	Zero Character	Slashed
Symbol Sets	Code Page	USA
Rear Feed	Line Spacing	6 LPI
Rear Feed	Form Tear-Off	Off
Rear Feed	Skip Over Perforation	No
Rear Feed	Page Length	11 "
Rear Feed	Gap Control	Auto Gap
Bottom Feed	Line Spacing	6 LPI
Bottom Feed	Form Tear-Off	Off
Bottom Feed	Skip Over Perforation	No
Bottom Feed	Page Length	11 "
Bottom Feed	Gap Control	Auto Gap
Top Feed	Line Spacing	6 LPI
Top Feed	Bottom Margin	Valid
Top Feed	Page Length	11 "
Top Feed	Gap Control	Auto Gap
Top Feed	Wait Time	1 sec
Set-Up	Graphics	Uni-directional
Set-Up	Receive Buffer Size	64K
Set-Up	Paper Out Override	No
Set-Up	Print Registration	0
		
Set-Up	Operator Panel Function	Full Operation
Set-Up	Reset Inhibit	No
Set-Up	Print Suppress Effective	Yes
Set-Up	Auto LF	No
Set-Up	Time Out Print	Valid
Set-Up	Auto Select	No
Set-Up	Smoothing	Valid
Set-Up	Ribbon Selection	Black
Set-Up	Printhead Gap Adjust	0
Set-Up	Graphics Speed	Low
Parallel I/F	I-Prime	Buffer Print
Parallel I/F	Pin 16	+5v
Parallel I/F	Auto Feed XT	Invalid
Printer Control	Emulation Mode	EPSON LQ
Printer Control	Emulation Mode	EPSON LQ

3-3-06.tif

This page was intentionally left blank.

Reset Menu to Factory Defaults

CAUTION:

Once the menu has been reset, all customized menu settings will be lost.

Always print the menu before resetting the printer to factory defaults.

To reset the menu to factory default settings:

1. Before resetting the Menu, Okidata **STRONGLY RECOMMENDS** printing the Menu.
Printing the Menu provides a reference of customized settings.
When the Menu is reset, all customized settings are **LOST**.
2. Power off the printer.
3. Press and hold SEL and LF while powering ON the printer.

Limited Operation

General Information

One of the menu selections that may be set by the end user is the operator panel function. This is found in the Set-up Group of the menu. Operator Panel Function is an item in the Set-up Group. This item may be set to either Full Operation or Limited Operation.

If the Operator Panel Function is set to Limited Operation the menu cannot be accessed and the operator panel switches listed below are not active.

1. Print Quality
2. Character Pitch

The Operator Panel Function item is frequently set to Limited Operation on networks or other areas where many users share a printer. Limited Operation prevents the printer settings from being changed.

This item cannot be changed through the OKISMART software. However, the print quality and character pitch may be set through your software application packages.

Procedure

To return the printer to Full Operation, you must modify the menu.

CAUTION:

Determine the preference of the end user regarding this feature. If the printer is on a network, do not reset this item without discussing the change with the network supervisor.

To access the menu when the printer is set to Limited Operation, follow this procedure.

1. Verify that continuous feed paper is installed.
2. Verify that the ribbon is correctly installed.
3. Verify that the width of the installed paper matches the paper width menu setting.

CAUTION:

If the Menu is set for wide paper, and narrow paper is used, the printhead will print on the platen. This could damage / destroy the printhead, platen, and ribbon.

4. Power off the printer.
5. Press and hold the SEL switch while powering on the printer.
6. The MENU lamp will light. If the printer was selected, the SELECT lamp will light.
When in Menu Mode, the functions printed below the operator panel switches are active.
7. Press GROUP until Set-Up prints.
8. Press ITEM until Operator Panel Function prints.
9. Press SET until FULL OPERATION prints.
10. Press EXIT to save the change and exit Menu Mode.

Menu Settings

Factory default settings are printed in ***Bold Italic***.

The tables show *all* possible menu settings available with the Microline 590/591.

What you will actually see depends on the active emulation and the options installed.

Group	Item	Setting
Printer Control	Emulation Mode	IBM PPR, IBM AGM, <i>Epson LQ</i>
Font	Print Mode	LQ Courier, LQ Roman, LQ Swiss, LQ Swiss Bold, LQ Orator, LQ Gothic, LQ Prestige, Utility
	Pitch	<i>10</i> , 12, 15, 17.1, 20 cpi
	Proportional Spacing	<i>No</i> , Yes
	Style	<i>Normal</i> , Italic
	Size	<i>Single</i> , Double
Symbol Sets	Character Set	<i>Set I</i> , Set II
	Language Set	<i>American</i> , French, German, British, Danish I, Swedish, Italian, Spanish I, Japanese, Norwegian, Danish II, Spanish II, Latin American, French Canadian, Dutch, Publisher
	Zero Character	<i>Slashed</i> , Unslashed
	Code Page	<i>USA</i> , Canada French, Multilingual, Portugal, Norway

- * Model 591 only
- ** Appears only when optional Roll Paper Stand is installed
- *** Appears only when IBM Proprinter emulation is selected
- **** Optional color ribbon must be installed to print colors other than black
- ***** Appears only when Epson LQ emulation is selected
- ***** Appears only when optional Serial Interface is installed
- ***** Appears only when optional Cut Sheet Feeder is installed

Factory default settings are printed in ***Bold Italic***.

The tables show *all* possible menu settings available with the Microline 590/591.

What you will actually see depends on the active emulation and the options installed.

Group	Item	Setting
Rear Feed	Line Spacing	6, 8 LPI
	Form Tear-Off	<i>Off</i> , 500 ms, 1 sec, 2 sec
	Skip Over Perforation	<i>No</i> , Yes
	Page Width *	<i>13.6"</i> , 8"
	Page Length	11 , 11 2/3, 12, 14, 17, 3 3.5, 4, 5.5, 6, 7, 8, 8.5 "
	Gap Control	<i>Auto Gap</i> , Semi Auto Gap, 1, 2, 3, 4, 5, 6, 7, 8, 9
Bottom Feed	Line Spacing	6, 8 LPI
	Form Tear-Off	<i>Off</i> , 500 ms, 1 sec, 2 sec
	Skip Over Perforation	<i>No</i> , Yes
	Page Width *	<i>13.6"</i> , 8"
	Page Length	11 , 11 2/3, 12, 14, 17, 3 3.5, 4, 5.5, 6, 7, 8, 8.5 "
	Gap Control	<i>Auto Gap</i> , Semi Auto Gap, 1, 2, 3, 4, 5, 6, 7, 8, 9
Top Feed	Line Spacing	6, 8 LPI
	Form Tear-Off * *	<i>Off</i> , 500 ms, 1 sec, 2 sec
	Bottom Margin	<i>Valid</i> , Invalid
	Page Width *	<i>13.6"</i> , 8"
	Page Length	11 , 11 2/3, 12, 14, 17, 3 3.5, 4, 5.5, 6, 7, 8, 8.5 "
	Gap Control	<i>Auto Gap</i> , Semi Auto Gap, 1, 2, 3, 4, 5, 6, 7, 8, 9
	Wait Time	1 sec , 2 sec, 500 ms
	Page Length Control	<i>by MENU Setting</i> , by Actual Page Length

- * Model 591 only
- ** Appears only when optional Roll Paper Stand is installed
- *** Appears only when IBM Proprinter emulation is selected
- **** Optional color ribbon must be installed to print colors other than black
- ***** Appears only when Epson LQ emulation is selected
- ***** Appears only when optional Serial Interface is installed
- ***** Appears only when optional Cut Sheet Feeder is installed

Factory default settings are printed in ***Bold Italic***.

The tables show *all* possible menu settings available with the Microline 590/591.

What you will actually see depends on the active emulation and the options installed.

Group	Item	Setting
Set-Up	Graphics	<i>Uni-directional</i> , bi-directional
	Receive Buffer Size	64K, 1 line, 32 K
	Paper Out Override	No , Yes
	Print Registration	0 0.05 mm Left 0.10 mm Left 0.15 mm Left 0.20 mm Left 0.25 mm Left 0.25 mm Right 0.20 mm Right 0.15 mm Right 0.10 mm Right 0.05 mm Right
	Operator Panel Function	<i>Full Operation</i> , Limited Operation
	Reset Inhibit	No , Yes
	Print Suppress Effective	Yes , No
	Auto LF	No , Yes
	Auto CR * * *	No , Yes
	SI Select Pitch (10 CPI) * * *	<i>17.1</i> , 15 cpi
	SI Select Pitch (12 CPI) * * *	<i>20</i> , 12 cpi
	Time Out Print	<i>Valid</i> , Invalid
	Auto Select	No , Yes
	Smoothing	<i>Valid</i> , Invalid
	Ribbon Selection * * * *	<i>Black Ribbon</i> , Black, Yellow, Magenta, Cyan, Violet, Orange, Green
	Printhead Gap Adjust	0 , - 1, + 1
	Graphics Speed	High, <i>Low</i>

- * Model 591 only
- * * Appears only when optional Roll Paper Stand is installed
- * * * Appears only when IBM Proprinter emulation is selected
- * * * * Optional color ribbon must be installed to print colors other than black
- * * * * * Appears only when Epson LQ emulation is selected
- * * * * * * Appears only when optional Serial Interface is installed
- * * * * * * * Appears only when optional Cut Sheet Feeder is installed

Factory default settings are printed in ***Bold Italic***.

The tables show *all* possible menu settings available with the Microline 590/591.

What you will actually see depends on the active emulation and the options installed.

Group	Item	Setting
Parallel I/F	I-Prime	<i>Buffer Print</i> , Buffer Clear, Invalid
	Pin 18	<i>+5v</i> , Open
	Auto Feed XT * * * * *	<i>Invalid</i> , Valid
Serial I/F * * * * * *	Parity	<i>None</i> , Odd, Even
	Serial Data 7/8 Bits	<i>8 Bits</i> , 7 Bits
	Protocol	<i>Ready / Busy</i> , X-ON / X-OFF
	Diagnostic Test	No, Yes
	Busy Line	<i>SSD-</i> , SSD+, DTR, RTS
	Baud Rate	19200, <i>9600</i> , 4800, 2400, 1200, 600, 300 bps
	DSR Signal	<i>Valid</i> , Invalid
	DTR Signal	<i>Ready on Power Up</i> , Ready on Select
	Busy Time	<i>200 ms</i> , 1 sec.
CSF Bin 1 * * * * * *	Line Spacing	<i>6 LPI</i> , 8 LPI
	Bottom Margin	<i>Valid</i> , Invalid
	Page Width *	<i>13.6"</i> , 8"
	Page Length	<i>11</i> , 11 2/3, 12, 14, 17, 3 3.5, 4, 5.5, 6, 7, 8, 8.5 "
	Gap Control	<i>Auto Gap</i> , Semi Auto Gap, 1, 2, 3, 4, 5, 6, 7, 8, 9
CSF Bin 2 * * * * * *	Line Spacing	<i>6 LPI</i> , 8 LPI
	Bottom Margin	<i>Valid</i> , Invalid
	Page Width *	<i>13.6"</i> , 8"
	Page Length	<i>11</i> , 11 2/3, 12, 14, 17, 3 3.5, 4, 5.5, 6, 7, 8, 8.5 "
	Gap Control	<i>Auto Gap</i> , Semi Auto Gap, 1, 2, 3, 4, 5, 6, 7, 8, 9

* Model 591 only

** Appears only when optional Roll Paper Stand is installed

*** Appears only when IBM Proprinter emulation is selected

**** Optional color ribbon must be installed to print colors other than black

***** Appears only when Epson LQ emulation is selected

***** Appears only when optional Serial Interface is installed

***** Appears only when optional Cut Sheet Feeder is installed

3.3.05 Top of Form

General Information

Top of Form is the distance from the top edge of the paper to the first print position on the page. The red line on the ribbon protector indicates the baseline of the Top of Form.

Setting Top of Form

1. Deselect the printer. The SEL lamp must not be lit.
2. To set the TOF further down the page, press and hold the SHIFT switch while pressing the FF/LOAD switch. This will advance the paper in micro increments.
3. To set the TOF higher on the page, press and hold the SHIFT switch while pressing the LF switch. This will retract the paper in micro increments.
4. This setting will be kept in memory until you power off the printer or until you change the setting.
5. To maintain this setting in the printer's memory (even when the printer is powered off), press and hold the SHIFT switch while pressing the QUIET/TOF switch.
6. Press the SEL switch.

Reset the Top of Form to Factory Default

1. Power off the printer.
2. Press and hold the QUIET and FF/LOAD switches while you power on the printer.

NOTE:

The factory default Top of Form Setting is 1 inch.

3.3.06 Paper Park

General Information

Paper Park allows the user to print using single (cut) sheet pages without removing continuous forms from the printer.

Procedure: Continuous Feed to Single Sheet

1. Remove any printed pages from the printer.
2. Press PARK to retract the continuous forms paper from the paper path.
3. Lift the paper separator to the upright position.
4. Move the paper lever to the TOP (Single Sheet) position.
5. Load the single sheet paper.

Procedure: Single Sheet to Continuous Feed

1. Remove any single sheet pages from the printer.
2. Lower the paper separator to the Continuous Forms position (rear feed).
3. Move the paper lever to the REAR or BOT position, as appropriate.
4. Lower the paper support.
5. Press FORM FEED to load the continuous forms paper into the printer.

NOTE:

When the printer is set to a different paper path, the printhead will travel back and forth. The pins are "gently" fired to sense paper thickness and set the printhead gap.

This page was intentionally left blank.

3.3.07 Tear Feature

NOTE:

Tear is activated by pressing TEAR. It is a manual procedure.

FORMS TEAR OFF is activated by changing a setting in the Menu. It is an automatic procedure.

General Information

This feature allows a printed page (rear or bottom feed, continuous form) to be torn off without wasting paper or adjusting the printer.

Tear Feature advances the paper from the initial printing position to the tear off position. The top of the page (perforation) will be even with the tear bar. The tear bar is located under the clear top of the access cover.

Paper will remain in the tear off position until the printer receives data. Then, the paper is retracted to the initial print position.

To activate the Tear Feature, press TEAR.

3.3.08 Forms Tear Off

NOTE:

Tear is activated by pressing TEAR. It is a manual procedure.

FORMS TEAR OFF is activated by changing a setting in the Menu. It is an automatic procedure.

General Information

This feature allows a printed page (rear or bottom feed, continuous form) to be torn off without wasting paper or adjusting the printer.

Forms Tear Off automatically advances the paper from the initial printing position to the tear off position. The top of the page (perforation) will be even with the tear bar. The tear bar is located under the clear top of the access cover.

Paper will remain in the tear off position until the printer receives data. Then, the paper is retracted to the initial print position.

When printing stops, the paper will advance to the tear off position.

NOTE:

If the software package being used "pauses" while sending data to the printer, Forms Tear Off may be activated (if it is enabled through the Menu). The pause must be for two or more seconds. No data is lost. Uneven print registration will occur due to the paper movement. If the problem occurs, deactivate Forms Tear Off through the Menu.

DO NOT use Forms Tear Off with labels or multi-part forms.

Remember to activate the Form Tear Off for the paper path you are using (rear feed or bottom feed).

Setting

1. Verify that continuous feed paper is installed.
2. Verify that the ribbon is correctly installed.
3. Verify that the width of the installed paper matches the paper width menu setting.
4. Power ON the printer.
5. Press and hold the SHIFT switch while pressing the SEL switch to place the printer in Menu Mode.

When in Menu Mode, the functions printed *below* the operator panels switches are active.

6. Press GROUP until the desired Group prints (Rear Feed or Bottom Feed).
7. Press ITEM until the desired Item prints (Form Tear Off)
8. Press SET until the desired setting prints (Off, 500 mS, 1 sec, 2 sec).
9. Press EXIT to save the change and exit Menu Mode.

Using

1. Load paper.
2. Press FORM FEED
3. The paper will advance past the start print position (Top of Form) to the tear bar position.
4. The paper stays in this position until the printer receives data. Then, the paper will be retracted to the appropriate Top of Form position.
5. A few seconds after printing stops, the paper advances to the tear bar position.

Checking Top of Form with Form Tear Off Activated

1. Load paper.
2. Press and *hold* TEAR. When you release TEAR, the paper will return to the tear off position.
3. The paper will retract to the Top of Form position.
4. Release TEAR.
5. The paper advances to the tear bar position.

3.3.09 Resets

Reset Menu to Factory Defaults

CAUTION:

Once the menu has been reset, all customized menu settings will be lost.

Always print the menu before resetting the printer to factory defaults.

To reset the menu to factory default settings, follow this procedure.

1. Before resetting the Menu, Okidata **STRONGLY RECOMMENDS** printing the Menu.
Printing the Menu provides a reference of customized settings.
When the Menu is reset, all customized settings are **LOST**.
2. Power off the printer.
3. Press and hold SEL and LF while powering ON the printer.

NOTE:

Refer to the Printer Handbook for a list of the factory default settings.

Reset the Top of Form to Factory Default

1. Power off the printer.
2. Press and hold the QUIET and FF/LOAD switches while you power on the printer.

NOTE:

The factory default Top of Form Setting is 1 inch.

3.4 CLEANING

3.4.01 General Information

An accumulation of paper dust is the most frequent cause of print quality problems in a dot matrix printer. Small pieces of paper can cause paper jams. A dirty platen will smudge paper. It is important to clean the printer regularly, paying particular attention to the printhead area and the paper paths.

If the lubrication procedures are not performed properly, the printer will require more frequent cleaning. Excessive lubricant attracts dust and accumulations build up quickly.

Keeping the covers in place and performing the cleaning procedures correctly will help ensure the highest quality printer output.

3.4.02 Cleaning Schedule

Routine inspection and cleaning should be performed:

1. every six months
or
2. every 300 hours of operating time.

3.4.03 Cleaning Tools

1. Clean, soft, lint-free cloth
2. All-purpose cleaner
3. Vacuum cleaner
4. Platen cleaner

3.4.04 Areas to be Cleaned

Area	Procedure	Cleaning Tool(s)
Carriage Shaft	3.2.25	Cloth and All-purpose cleaner
Area around carriage shaft	3.2.25	Vacuum, Cloth, and All-purpose cleaner
Space Rack	3.2.13	Vacuum
Paper Paths	N/A	Vacuum, Cloth, and All-purpose cleaner
Platen	3.2.19	Cloth and Platen cleaner
Covers	3.2.06	Cloth and All-purpose cleaner

3.5 LUBRICATION

3.5.01 General Information

If the lubrication procedures are not performed properly, the printer will require more frequent cleaning. Excessive lubricant attracts dust and accumulations build up quickly. An accumulation of paper dust is the most frequent cause of print quality problems in a dot matrix printer.

3.5.02 Lubrication Schedule

Routine inspection and lubricating should be performed:

1. once a year
or
2. every 600 hours of operating time.

3.5.03 Lubrication Types

1. Machine Oil or equivalent
2. Moly-lube Grease or equivalent

3.5.04 Lubrication Amounts

Do NOT over-lubricate the printer. Operational problems are caused by excess lubricant. The excess lubricant causes dust to accumulate. These accumulations can jam gears or cause print problems.

The Lubrication Table will direct you to use the following amounts of lubricant.

1. Medium
 - Oil: three to four drops
 - Grease: thin coating (approximately .015 inch)
2. Small
 - Oil: one drop
 - Grease: extremely thin coating (approximately .008 inch)

3.5.05 Lubrication Table

Area to be Lubricated	Disassembly Procedure	Lubricant	Amount
Visible Bearings of Gears in Gear Case Assembly	3.2.04	Oil	Small
Bearing of Pull-up Roller Shaft	3.2.05	Grease	Medium
Contact between Idle Gear Bearing and Pull-up Roller Shaft	3.2.05	Grease	Medium
Contact of Space Motor Assembly Gear and Space Rack	3.2.11	Oil	Small
Contact between Platen Shaft and Platen Ground Spring	3.2.19	Grease	Small
Contact between Bias Gear and Platen Gear	3.2.19	Oil	Small
Bearing of Change Lever	3.2.23	Grease	Medium
Bearing and Pivot Point of Change Lever	3.2.23	Grease	Medium
Pivot Point of Release Cam	3.2.24	Grease	Medium
Holder on Pressure Spring	3.2.24	Grease	Medium
Bearing of Front Release Gear Arm	3.2.24	Grease	Medium
Carriage Shaft NOTE: Place a small amount on the surface, then wipe clean.	3.2.25	Oil	See NOTE
Front Release Gear Shaft	3.2.27	Grease	Medium
Contact between Front Roller Holder and Front Pressure Roller	3.2.28	Oil	Small
Bearing of Tractor Gear	3.2.29	Grease	Medium
Contact between Lower Tractor Feed Shaft and Main Frame	3.2.29	Grease	Medium

3.5.06 Areas Not Lubricated

Lubricant should never contact the parts listed below.

1. Ribbon
2. Platen Assembly (Rubber Face)
3. Pressure Roller (Rubber Face)
4. Tractor Pins
5. Head Cable
6. Space Motor Printed Circuit Board
7. Electrical Contacts and Connections
8. Space Rack

3.6 SHIPPING INSTRUCTIONS

3.6.01 Return for Service

CAUTION:

When shipping the printer, use the original packaging to prevent damage.

Be sure to secure the printhead so it will not move during shipment.

1. Locate the original packaging or order replacement packaging from Okidata. (Refer to Appendix B)
2. Make sure the printhead is secured so it will not move during shipment.
3. Remove the platen knob. Be sure to place it in the shipping container.
4. Pack the unit, using the materials from Step 1.

3.6.02 All Other Returns

CAUTION:

The product MUST be returned in the original packaging.

The product MUST be returned with ALL originally supplied factory items.

Be sure to secure the printhead so it will not move during shipment.

1. Locate the original packaging or order replacement packaging from Okidata. (Refer to Appendix B)
2. Locate the originally supplied factory items.
(Refer to Setting Up in the Printer Handbook)
3. Make sure the printhead is secured so it will not move during shipment.
4. Pack the unit, using the materials from Step 1.

This page was intentionally left blank.

SECTION FOUR
FAILURE ANALYSIS

4.1 OVERVIEW

4.1.01 Introduction

This section is used to isolate problems to the assembly level. Application problems and detection of faulty components on the printed circuit boards are NOT addressed.

When troubleshooting a defective unit, follow these steps.

1. Refer to Section 4.3, which explains where to check for updates to the troubleshooting information.
2. Section 4.4 contains tips on preventing problems, as well as a list of common problems.
3. Section 4.5 shows samples of abnormal outputs.
4. Section 4.6 provides tables of error messages.
5. Section 4.7 contains the Repair Analysis Procedures (RAPs). Each RAP will ask you questions or require you to make observations. The answers to these questions and the results of your observations determine your next course of action. Use the RAP Index to identify which RAP should be used to resolve the problem with the machine.
6. Section 4.8 provides the procedures for various printer tests.
7. Section 4.9 lists the resistance check points.
8. Section 4.2 lists methods for reporting problems. If you encounter a situation that is NOT addressed by the documentation in this kit, please report the problem to Okidata, using one of the methods listed.

Refer to the Service Center Reference Guide for information on contacting Okidata.

This page was intentionally left blank.

4.1.02 Printer Serial Number Identification

To identify the revision level of a printer, record the serial number from the back of the printer. Refer to the following to decode the serial number.

Example Printer Serial Number: 401A0154693

Date Code 401 (4 = year. 01 = month)

Revision A

Serial Number 0154693

4.2 REPORTING PROBLEMS

4.2.01 General Information

Okidata strives to provide accurate and detailed service information through its training materials. The Technical Training Group realizes that service technicians have valuable experience, knowledge, and opinions. Okidata strongly encourages you to report any problems you may encounter when using the materials of this training kit. Please be as specific and detailed as possible. Your comments, suggestions, and criticisms are used to update and revise training kits.

You should reference the training materials when servicing Okidata products. Most problems can be solved by using the information provided in the training materials. If you encounter a situation that cannot be solved, please let Okidata know.

Refer to the Service Center Reference Guide for information on contacting Okidata.

4.2.02 Problem Lists

Technicians frequently request a list of common problems specific to a product. Technical Training Kits are written before a product is shipped to customers. Therefore, such information is NOT available when a product is first released.

However, Okidata wants to respond to these requests. Okilink II provides round-table discussions on technical problems. Errors and corrections in the training materials are listed in the Training Section of Okilink II. The Technical Service Bulletins (also known as Okidata's Monthly Mail) are available via Okilink II. Situations that are NOT addressed in the reference documentation, technical service bulletins, or round-tables may be reported to the Dealer Service and Support Engineers (Contact Technical Support) or the Technical Training Group. You will receive a response to your message within one business day.

The information on Okilink II is the most accurate and up-to-date technical information available from Okidata. This is only possible with your assistance. By reporting your suggestions, concerns, and problems, Okidata can provide the best possible information.

Your cooperation is greatly appreciated. Thank you for your help!

4.2.03 Reporting Methods

Okilink II

You may use Okilink II to report your findings. Refer to the Service Center Reference Guide for information on using Okilink II.

Course Critique

Use the Course Critique to report any problems you find as you are completing the self-paced training.

Fax Number

If you wish to fax your response, please use the numbers listed in the Service Center Reference Guide.

Mailing Address

If you respond by mail, please use the appropriate address listed in the Service Center Reference Guide.

Information Provided

Please provide the following information when reporting problems.

Okidata Dealer Number

Technician's Name

Company Name

Company's Address (Street, City, State/Province, ZIP / Postal Code, Country)

Telephone and Fax Numbers (with area / country access codes)

Product Name

Unit's Serial Number

Firmware Revision Level

Description of Problem

Document Name (with page number or procedure) with error or problem.

4.3 TROUBLESHOOTING UPDATES

4.3.01 General Information

Okidata distributes updated troubleshooting information in three ways.

Okilink II

Faxable Facts

Technical Service Bulletins

4.3.02 Okilink II

Okilink II is Okidata's Bulletin Board Service. This service is available to all Okidata Certified Service Technicians. Okilink II provides troubleshooting and service information. Technicians can download files, ask questions of Okidata's technical support personnel, and participate in round table discussions about Okidata products and services. Technical Service Bulletins, Recommended Spare Parts Lists, Printer Drivers, Product Specifications, and Service Training Information are also available.

Refer to the Service Center Reference Guide for information on accessing Okilink II.

4.3.03 Faxable Facts

Okidata's Faxable Facts is an automated fax document retrieval system. It is maintained by Okidata's Customer Information Center. Answers to common questions about Okidata products are available through Faxable Facts.

Refer to the Service Center Reference Guide for information on accessing Faxable Facts.

4.3.04 Technical Service Bulletins

Okidata's Technical Service Bulletins (TSBs) contain technical information developed after product release. Firmware updates, part number changes, and procedural changes are some of the subjects covered by these bulletins. The TSBs are distributed through Okilink II.

Refer to the Service Center Reference Guide for information on accessing Okilink II.

4.4 TROUBLESHOOTING TIPS

4.4.01 Preliminary Checks

1. Is the product being operated under the proper ambient conditions?
2. Does the paper being used meet the specifications for this product?
3. Has the ribbon been replaced as recommended?
4. Has the ribbon been installed properly?
5. Is an Okidata ribbon being used?
6. Is the printhead gap correctly set?
7. Is the firmware the latest (current) revision?
8. Are the printer drivers being used correct for the printer?
9. Is the printer driver being used the latest (current) release?

4.4.02 Problem Categories

There are three categories of problems that you might encounter when servicing the printer.

ALARM Lamp Blinks (Fatal Errors)

The following can cause the ALARM lamp to blink.

- Open Bail Arm
- Jammed Paper
- Printhead Cannot Move
- Other Fatal Error

When the ALARM Lamp is blinking, check the items listed below.

1. Close the bail arm.
2. Check for a paper jam.
3. Verify that the printhead moves freely.
4. Record the status of the ALARM, PRINT QUALITY, and CHARACTER PITCH Lamps.
5. Refer to the Alarm Lamp Codes Table. (Section 4.6)
6. Locate the error.
7. Perform the designated corrective action.

Operational Errors

An Operational Error is usually not accompanied by an ALARM Lamp.

Refer to the Start Here Flowchart (Section 4.4.03) and perform the corrective action.

ALARM Lamp Lights (Paper End/Jam Conditions)

A solid ALARM Lamp usually indicates a cover open, paper jam or paper-end (out of paper) condition.

4.4.03 START HERE Flowchart

START

Power ON the unit.

Does the printer initialize?

No Is the ALARM Lamp Blinking?

No Refer to RAP 01.

Yes Refer to Section 4.6 of the Service Handbook.

Yes Load the printer with paper.

Does the paper load without jamming?

No Refer to Rap 04.

Yes Perform the Rolling ASCII test. Refer to Section 3 of the Service Handbook.

Is the output satisfactory?

No Refer to RAP 06.

Yes Are all operator panel switches operating properly?

No Refer to RAP 09.

Yes Has the problem been resolved?

Yes End of procedure.

No Does the parallel or serial interface port receive data from the host PC properly?

Yes End of procedure.

No Which port is not receiving data?

Parallel Refer to RAP 10.

Serial Refer to RAP 11.

4.4.04 Tips for Preventing Image Problems

1. Make sure that the ribbon is not "dried out". If the printer output is faded, install a new ribbon, then print another sample.
2. Make sure that the paper you are using is within specifications. Paper specifications can be found in Section 1 of this Service Handbook.

4.4.05 Common Problems

1. Nothing happens when the unit is powered on.

The unit may not be plugged in. Check the power cord connection to the outlet and to the printer. If a power strip is being used, make sure that it is powered ON. Check to be sure that an external fuse hasn't blown or that a circuit breaker hasn't tripped.

2. The printer does not print when the computer sends data.

The printer may be deselected. If the SEL light is out, press the SEL button to select the printer.

The printer cable may not be securely connected. Check the cable to be sure that it is properly connected to both the PC and the printer.

If you have installed the serial interface board, check to be sure that the board is firmly seated in the printer.

3. A brand new ribbon has been installed and the printing is smeared and streaked.

The plastic shield on the ribbon is either loose or missing. The shield must be left on the ribbon when you are installing the cartridge. To remedy this situation, move the printhead to the center of the platen (careful - the printhead may be HOT!) and lift off the ribbon cartridge. Check the ribbon shield. If it is loose, secure it in place properly. If it is missing, locate it and install.

4. Static electricity causes the paper to stick.

In cold, dry weather, static charges can build up on continuous-form paper. This can make the paper cling to the paper separator. If you have this problem during high-volume printing jobs, try moving the single sheet paper guides on the separator together so that the paper rests on the guides rather than on the separator itself.

5. The Print Quality and Character Pitch buttons on the front panel won't work.

The Operator Panel Function Item on the printer MENU can be used to disable these buttons. If the printer is part of a customized system or if it is used by a number of people, the system manager may have used this option to make sure the printer is always set properly.

NOTE:

This feature also prevents access to the Menu. To access the Menu, power OFF the printer, then hold down the SEL key while powering ON.

6. Strange symbols and incorrect fonts appear on the output when a document is printed.

The printer driver that is engaged does not agree with the emulation selected for the printer.

To check the emulation selected, first make sure that paper is loaded. Then, press the SEL and SHIFT buttons simultaneously to enter the Menu Mode. Next, press the GROUP button. This will print the emulation selected.

If the emulation is not the one you want to use, press the SET button to change it to the one you want before exiting the Menu Mode. To exit, press the SEL and SHIFT buttons.

If the emulation is correct, check your software documentation on how to select a printer driver. Then, check to be sure that you have selected one of the drivers listed for that emulation. Refer to the Printer Handbook for emulation/driver selections. The closer the driver is to the top of the list in the Printer Handbook, the more compatible it will be with your printer. If your software does not have any of the indicated drivers available, check with the software manufacturer to see if they have added any additional drivers since you purchased your software.

If you have embedded any printer commands in your software, check to be sure that you have entered them correctly.

7. Printing on the right side of the page is lighter or darker than the rest of the print on the page.

Although the printer automatically sets the head gap, it sometimes may need a minor adjustment. To make this adjustment, enter the Menu Mode. Press SEL and SHIFT buttons simultaneously. To change the setting for the Printhead Gap Adjust under the Setup Group, use the following procedure.

Press GROUP until Setup Group prints.

Press ITEM until Printhead Gap prints.

Press SEL to change the setting. The default setting is 0. If the printing is sometimes lighter, change the setting to - 1. If it is sometimes darker, change it to + 1.

Press SEL and SHIFT buttons simultaneously to exit Menu Mode.

8. There are vertical spacing problems when using continuous forms and Forms Tear Off.

The Microline 590/591 does not have a bail arm, so pages do not feed as high as printers with bail arms. The first page does not line up correctly. Enter Menu Mode and disable Form Tear Off. Exit Menu Mode. Deselect the printer and set the paper position, using the Micro Feed buttons (hold SHIFT while pressing MICRO FEED UP or DOWN). Enter Menu Mode and enable Form Tear Off. Exit Menu Mode.

9. The ALARM light is not on, but paper needs to be loaded.

If the ALARM light is off, the printer "thinks" that paper is loaded. To correct this problem, press and release the SEL button. Then, hold the SHIFT button and press the RESET (Character Pitch) button. The ALARM light will come on and you will be able to load paper.

10. The ALARM light is on and the Character Pitch 15 light is flashing.

This indicates a paper loading error. To stop the flashing light, press the SEL button. Before trying to load paper, check to be sure that you have the paper lever in the correct position (BOT, TOP, REAR) for the path that you are using.

CAUTION:

Always power OFF the printer before you turn the platen knob.

If the paper lever is in the correct position and you are using rear feed, lift up the paper separator and check to be sure that the paper is properly on the tractors and has not jammed.

If the paper lever is in the correct position and you are using the optional bottom-feed push tractor, check the bottom tractor unit to be sure that the paper is properly installed on the tractors and that the paper has not jammed.

Once the paper is correctly loaded, press and release the SEL button, then hold the SHIFT button and press the RESET (Character Pitch) button.

11. Word processor files do not print the way the MENU and front panel are set.

Before sending a file to the printer, many word processors send either an initialization string or an I-Prime signal to the printer.

The initialization string contains codes that reset the printer to a default set of features. Otherwise, the printer might accidentally print using features set for a previous job. These codes will override the panel or MENU settings. To set your printer to ignore the reset codes, enter the printer MENU (hold down the SHIFT button while pressing SEL/MENU button) and change the Reset Inhibit item (in the Setup Group) to Yes. Please note that while this will stop the reset code from resetting your printer, other codes in the initialization string may still override the printer MENU and / or front panel settings.

The I-Prime signal is sent over the parallel interface (pin 31) and will automatically override any settings you have made using the front panel buttons. To eliminate this problem, enter the Menu Mode (hold down the SHIFT button while pressing SEL/MENU button) and change the I-Prime item (in the Parallel I/F Group) to Invalid.

4.5 ABNORMAL OUTPUT

4.5.01 Output Samples

Light Print on the Entire Page

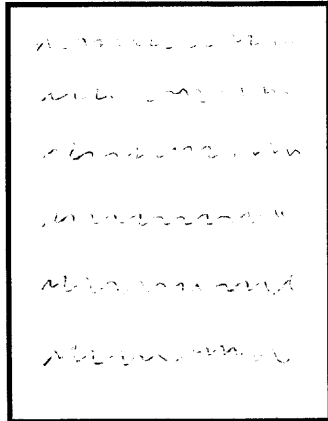

Uneven Print Density

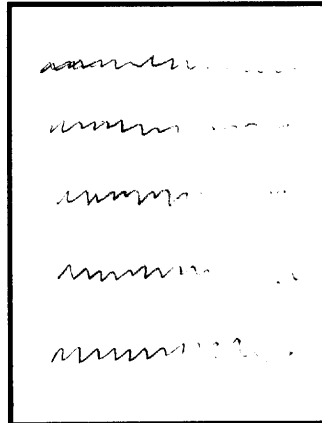

Smeared Print

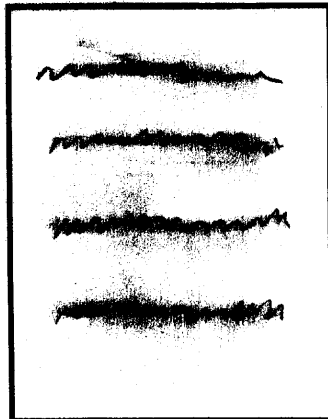

Inconsistent Line Feed

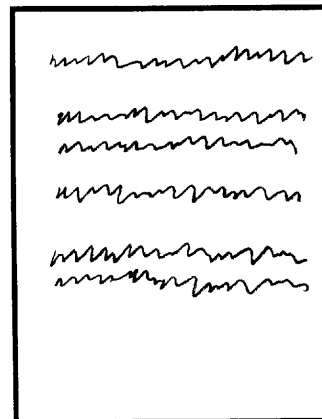

Drifting Margin

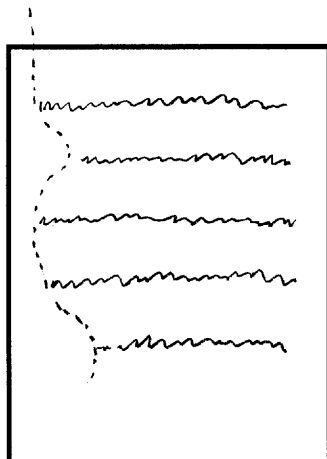

4-5-01.pcx

Light Print on the Entire Page

Possible Causes:

1. Ribbon is "dried out". Replace the ribbon.
2. Verify that the headgap menu setting is appropriate for the type of paper being used.
3. Check / perform the printhead gap adjustment.
4. Paper is not within specification. Refer to Section One for paper specification.

Uneven Print Density

Possible Causes:

1. Printhead gap not within specification. Perform the printhead gap adjustment.
2. Defective platen. Replace the platen.

Smearred Print

Possible Causes:

1. Ribbon protector is missing or broken. Replace the ribbon protector.
2. Verify that the headgap menu setting is appropriate for the type of paper being used.
3. Check / perform the printhead gap adjustment.
4. Paper is not within specification. Refer to Section One for paper specification.

Inconsistent Line Feed

Possible Causes:

1. Power OFF the printer. Turn the platen knob. The platen should rotate smoothly. If it does not, remove the cause of the binding.
2. Defective line feed motor. Replace the line feed motor.

Drifting Margin

Possible Causes:

1. Power OFF the printer. Move the carriage assembly. The carriage should move smoothly. If it does not, remove the cause of the binding.
2. Refer to the next section and / or Technical Service Bulletin 3309.

This page was intentionally left blank.

Left Margin Drifting Problem

NOTE:

This information is also provided in Technical Service Bulletin 3309.

To correct a problem with the left margin drifting during print operations, follow this procedure.

1. Manually slide the carriage assembly back and forth along the full length of the carriage shaft.

Check for "drag" caused by the ribbon, a dirty space rack, or other obstructions.

If you suspect that the ribbon is causing movement problems, check the movement of the carriage assembly with the ribbon removed *OR* with a new ribbon installed.

2. Check the contact between the carriage frame and the space motor board assembly.

Contact is made at the front edge of the board.

Any gap will keep the space motor gear from fully engaging with the space rack. This will result in slippage problems, which will affect spacing operations.

3. Check the printhead cable connections between the main control board and the space motor. Solid contact *MUST BE* made at all connections or print problems will occur.
4. Check the condition of the printhead cable. If it is broken, torn, or sharply bent, replace the cable.
5. If the problem continues, check the parts listed below (in the order given). Replace the suspected part. Be sure to test the printer after replacing each part.

1. Carriage: Frame Set
2. Motor: Space
3. Rack: Space
4. Cable: Printhead
5. Board: Main Control

6. If the problem continues, check all assemblies and connections. Then, contact Okidata Technical Information for further assistance.

4.6 FAULT ALARMS

4.6.01 General Information

Follow these guidelines when using the Troubleshooting Tables.

1. Record the status (OFF, solidly ON, Flashing) of the Operator Panel LEDs.
2. Go to to the Troubleshooting Table Index (Section 4.6.02).
3. Look for the LED Indications you have observed.
4. The Reference Number in the column at the right side of the Troubleshooting Table Index directs you to the appropriate item in the Troubleshooting Tables (Section 4.6.03).
5. The Troubleshooting Tables will provide a Failure Description, Probable Cause and Recommended Action.
6. The Recommended Action will direct you to the actions listed below.

Follow a specific RAP

Replace items in a listed order.

4.6.02 ALARM/LED Display Troubleshooting Table Index

ALARM	UTILITY	PROP	PRESTIGE	ORATOR	10	12	15	17	20	SEL	MENU	Reference Number
												1
												2
												3
												4
												5
												6
												7
												8
												9
												10
												11
												12
												13
												14
												15
												16
												17
												18
												19
												20
												21
												22
												23
												24
												25
												26

Shading	Lamp Status
	OFF
	ON - Solid
	ON - Flashing

NOTE:

Reference Numbers 25 and 26 use identical Operator Panel displays

4.6.03 ALARM/LED Display Troubleshooting Tables

Reference Number	Failure Description	Cause	Recommended Action
1	Space Motor Alarm	Space motor IPT does not occur in specified time	Refer to RAP 02.
2	Printhead Detection Alarm	Printhead does not home	Refer to RAP 03.
3	Printhead A/D Alarm	Thermistor is open, or +5 vdc shorted	Check the printhead connection then, replace, main control board, carriage cable, printhead
4	Printhead Gap Alarm	Self adjustment was not successful	Check the printhead connection then, replace the main control board, carriage cable, printhead
5	Printhead Data Transfer Alarm	Printhead parity error	Replace main control board, carriage cable, printhead
6	Printhead Type Alarm	9 pin printhead is connected in a 24 pin printer	Replace the printhead with a 24 pin printhead
7	Printhead Connection Alarm (1)	Drive current is detected during no overdrive signal	Check the printhead connection then, replace, main control board, carriage cable, printhead
8	Printhead Connection Alarm (2)	Overdrive signal is active but no current is detected	Check the printhead connection then, replace main control board, carriage cable, printhead
9	Line Feed / Space Motor Driver Alarm	High driver temperature, the TSD signal has not changed	Replace the following: main control board, linefeed motor, space motor
10	MPU Internal RAM Alarm	Read/write error	Replace the main control board
11	Program ROM Alarm	Checksum error	Replace the ROM and / or main control board.
12	RAM on Main Control Board	Read/write error	Replace the main control board

Reference Number	Failure Description	Cause	Recommended Action
13	CG ROM Alarm	Checksum error	Replace the main control board, and/or CG ROM
14	EEPROM Alarm	No reaction when the MPU reads data	Replace the main control board
15	Watchdog Timeout Alarm	MPU hung up	Power OFF, then ON
16	NMI Signal Alarm	NMI port of MPU kept low	Replace the main control board
17	BRK Instruction Alarm	FFFF data detected due to MPU hang up	Replace the ROM on the main control board
18	MPU Internal RAM Alarm	Read/write error	Replace the interface board
19	ROM alarm	Check sum error	Replace the interface board
20	RAM on I/F board alarm	Read/write error	Replace the interface board, then, the main control board
21	Interface not connected	Serial interface board not detected	Replace the interface board, replace the main control
22	Paper End Alarm	From the cut sheet feed or bottom feed paper end	Check paper supply. Refer to RAP 04
23	Paper Change Lever Alarm	Change lever is set for top feed while paper is inserted from rear or bottom	Set the lever to the specified position, check the rear sensor lever, replace the main control board
24	Cut Sheet Jam	Cut sheet could not be fed properly	Remove the paper check the feed mechanism, Press SEL
25	Printhead Thermal Alarm	Printhead temperature exceeds 115 degrees	Wait until the printhead cools. The printer should resume printing. If the problem persists, replace the printhead, replace the main board
26	Space Motor Thermal Alarm	Temperature of space motor exceeds specified value	Wait until the printhead cools. The printer should resume printing. If the problem persists, replace the space motor, then replace the main control board

4.7 REPAIR ANALYSIS PROCEDURES (RAPs)

4.7.01 Using the RAPs

When using the Repair Analysis Procedures, follow these steps.

1. Go to the RAP Index.
2. Find the RAP which is associated with the printer's problem.
3. Go to the appropriate RAP.
4. All RAPs begin with a START statement, followed by questions or another type of statement.

4.7.02 RAP Index

RAP Number	Description
1	No Power Supplied to Printer
2	No Spacing Operation
3	Printhead Homing Error
4	Paper Jam During Paper Loading
5	Printhead Not Firing Pins
6	Poor Print Quality
7	Ribbon Feed Problem
8	Line Feed Problem
9	Operator Panel Malfunction
10	Parallel Interface Problem
11	Serial Interface Problem

RAP 01 No Power Supplied to Printer

START

The printer does not power On when the AC switch is turned ON.

Check the AC cable.

Is it correctly connected?

Yes Check the fuse on the power supply board and F1 of the main control board.
Are they open?

No Go to A.

Yes Replace the fuse(s) with fuse(s) of the same rating.

Is the problem resolved?

Yes End of procedure.

No Go to A.

B

No Remove the cable from CN3 on the main control board.

Refer to Appendix A of this Service Handbook for voltage check points on CN3 of the main control board. Check the output voltages of the secondary of the transformer.

Replace the following in the order listed below. Check operation before replacing next item in list.

1. Operation Panel.
2. Power Transformer.

Has the problem been resolved?

Yes End of procedure.

No Contact Technical Support.

A

Remove the cable from CN7 of the main control board. Then, power ON the unit.

Do the operation panel LEDs light?

No Go to B.

Yes Power OFF the unit. Remove the printhead. Power ON the unit.

Has the problem been resolved?

Yes Replace the printhead.

Has the problem been resolved?

Yes End of procedure.

No Go to B.

No Replace the following in the order listed below. Check operation before replacing next item in list.

1. Ribbon Feed Mechanism.
2. Carriage Cable.
3. Main Control Board
4. PROM 05CA

Has the problem been resolved?

Yes End of procedure.

No Contact Technical Support.

RAP 02 No Spacing Operation

START

The alarm LED blinks.

Is the carriage assembly binding or jammed?

No Make sure the carriage cable is properly connected to the space motor assembly and CN7 on the main control board.

Go to A.

Yes 1. Remove the ribbon to verify that the ribbon is not jammed.
2. Remove the space motor assembly
3. Inspect the teeth on the space rack and the space motor gear.
4. Go to A.

A

Has the problem been resolved?

Yes End of procedure.

No Is the fuse F2 on the main control board open?

No Go to B.

Yes Replace the main control board.

Has the problem been resolved?

Yes End of procedure.

No Go to B.

B

Verify that +40 volts is present on CN7 main control board (Refer to Appendix A of the Service Handbook).

Has the problem been resolved?

Yes End of procedure.

No Replace the carriage cable.

Has the problem been resolved?

Yes End of procedure.

No Replace the ribbon feed mechanism

Has the problem been resolved?

Yes End of procedure.

No Replace the PROM (O5CA)

Has the problem been resolved?

Yes End of procedure.

No Contact Technical Support.

RAP 03 Printhead Homing Error

START

Printhead does not return to the home position.

Make sure the carriage cable is properly connected to the space motor assembly and CN8 on the main control board.

Make sure the power connector cable is properly connected to CN3 on the main control board.

Does the space motor assembly move manually?

No Remove the space motor assembly and inspect the space motor and space rack for dirt and worn teeth.

Go to A

Yes Are there any breaks in the carriage cable?

Yes Replace the carriage cable assembly.

Go to A

No Verify that ribbon feed mechanism is properly fastened to the space motor assembly.

Go to A

A

Does the carriage move slightly to the left after turning the power on?

No Replace the space motor assembly.

 Has the problem been resolved?

 Yes End of procedure.

 No Contact Technical Support.

Yes Replace the ribbon feed assembly.

 Has the problem been resolved?

 Yes End of procedure.

 No Replace the main control board.

 Has the problem been resolved?

 Yes End of procedure.

 No Replace the space motor assembly.

 Has the problem been resolved?

 Yes End of procedure.

 No Contact Technical Support.

RAP 04 Paper Jam During Paper Loading

START

Check paper path release lever for proper position. Make sure the paper path is clear.

Which of the following paper jams have occurred?

1. Paper bent at top left corner.

Check the support protector to see if it covers the left side of the paper properly.

Go to A.

2. Paper has torn ends.

Check the ribbon protector.

Check the pull up roller cover to see that it is closed properly.

Go to A.

3. Paper squeezed from either end.

Check around the pressure roller mechanism.

Check the front pressure springs to see that they are mounted properly. There are three springs in the Microline 590 and five springs in the Microline 591.

Check the tension of all the front pressure rollers to see if they are the same. Top springs: 250 g. Rear Springs: 90 g.

Make sure that the front release gear arm and the gear of the front release gear shaft are in the proper position.

Go to A.

A

Has the problem been resolved?

Yes End of procedure.

No Check that the head gap is set properly.

Has the problem been resolved?

Yes End of procedure.

No Contact Technical Support.

RAP 05 Printhead Pins Not Firing

START

Missing dots on output.

Verify that the printhead gap is set correctly.

Ensure the carriage cable is making firm contact with CN7 on the main control board and the space motor assembly. Inspect both ends of the carriage cable for worn edges.

Has the problem been resolved?

Yes End of procedure.

No Replace the printhead.

Has the problem been resolved?

Yes End of procedure.

No Replace the main control board

Has the problem been resolved?

Yes End of procedure.

No Replace the carriage cable.

Has the problem been resolved?

Yes End of procedure.

No Replace the space motor assembly.

Has the problem been resolved?

Yes End of procedure.

No Contact Technical Support.

RAP 06 Poor Print Quality

START

Is the print head gap properly set?

Yes Go to A

No Go to B

A Replace the printhead

Has the problem been resolved?

Yes End of procedure.

No Go to C.

C Replace the main control board.

Has the problem been resolved?

Yes End of procedure.

No Check that the carriage cable is making good contact with the main control board and the carriage assembly. Replace the cable if it is worn or bent.

Has the problem been resolved?

Yes End of procedure.

No Contact Technical Support.

B Adjust the print head gap (See Section 3 of the Service Handbook).

Has the problem been resolved?

Yes End of procedure.

No Power ON the unit and view the head gap indicator.

Does the head gap indicator display a range of 9?

Yes Go to A

No Replace the ribbon feed mechanism.

Has the problem been resolved?

Yes End of procedure.

No Go to C

RAP 07 Ribbon Feed Problem

START

The ribbon feed does not function properly.

Verify that both ends of the carriage cable are connected correctly.

Make sure the ribbon shield is fastened properly.

Remove the ribbon cartridge.

Grasp the carriage. Manually move the carriage left and right.

Does the ribbon drive shaft rotate?

Yes Change the ribbon cartridge.

End of procedure.

No Remove the ribbon feed mechanism.

Manually move the carriage left and right.

Does the space motor shaft rotate freely?

Yes Replace the ribbon feed mechanism.

End of procedure.

No Replace the space motor assembly.

Has the problem been resolved?

Yes End of procedure.

No Replace the main control board.

Has the problem been resolved?

Yes End of procedure.

No Contact Technical Support.

RAP 08 Line Feed Problem

START

No line feed operation.

Make sure that the line feed cable is properly connected to the line feed motor and CN5 of the main control board.

Power OFF the printer. Manually rotate the platen.

Does the platen rotate smoothly?

Yes Go to A

No Is the left platen gear broken?

Yes Replace the platen assembly.

End of procedure.

No Is the line feed idle gear broken?

Yes Replace the line feed motor assembly or the line feed idle gear.

End of procedure.

No Are the right platen gear, idle gear and/or change gear broken?

Yes Replace the respective assembly.

End of procedure.

No Set the change lever to the rear position.

Does the platen rotate smoothly?

Yes Replace the tractor feed assembly.

End of procedure.

No Check the gears on the tractor feed assembly and platen assembly for broken or missing teeth. Replace the defective assembly.

Go to A

A

Replace the line feed motor assembly.

Has the problem been resolved?

Yes End of procedure.

No Replace the main control board.

Has the problem been resolved?

Yes End of procedure.

No Contact Technical Support.

This page was intentionally left blank.

RAP 09 Operation Panel Malfunction

START

The operation panel does not function properly.

Do the operation panel LEDs light when power is applied?

Yes Make sure the cable from CN1 of the operation panel is properly connected to CN7 on the main control board.

Go to A

No Check the F1 fuse on the main control board and the fuse on the power supply board. Are they open?

Yes Replace the open fuse with one that has the proper rating.

Go to A

No Replace the power supply unit.

Go to A

A

Has the problem been resolved?

Yes End of procedure.

No Replace the operation panel board.

Has the problem been resolved?

Yes End of procedure.

No Replace the main control board.

Has the problem been resolved?

Yes End of procedure.

No Contact Technical Support.

RAP 10 Parallel Interface Problem

START

No parallel port communication.

Is the SEL LED blinking?

Yes The printer is in the Print Suppress mode.

Disable the menu item Print Suppress if the function is not required.

End of procedure.

No Does the SEL LED light ?

Yes Go to A

No Press SEL key.

Has the problem been resolved?

No Disconnect the cable.

Does the SEL LED light ?

Yes Change the menu item I-prime to invalid.

No Go to A

Yes Is data being received properly?

Yes End of procedure.

No Check that the cable is properly connected to the Host PC and the correct LPT port is selected.

Does the SEL LED light?

No Go to A

Yes Change the menu item I-prime to invalid.

End of procedure.

A

Replace the interface cable.

Has the problem been resolved?

Yes End of procedure.

No Replace the main control board.

Has the problem been resolved?

Yes End of procedure.

No Contact Technical Support.

RAP 11 Serial Interface Problem

START.

Are you using a cable with proper number of pins?

No Change the interface cable.

Has the problem been resolved?

Yes End of procedure

No Go to A

Yes Is the ALARM LED blinking?

Yes Refer to Section 4.6 of the Service Handbook.

Has the problem been resolved?

Yes End of procedure

No Go to A

No Check the following parameters for the RS232C: baud rate, bit length, parity, protocol, busy signal and parity.

Has the problem been resolved?

Yes End of procedure

No Go to A

A

Check the voltages on the main control board.

Is 10 VAC being supplied to the main control board?

Yes Replace the RS232C board.

Has the problem been resolved?

Yes End of procedure.

No Replace the main control board.

Has the problem been resolved?

Yes End of procedure.

No Contact Technical Support.

No Replace the power supply unit.

Has the problem been resolved?

Yes End of procedure.

No Replace the RS232C board.

Are + 8 vdc / - 8 vdc present on the main control board?

Yes Replace the RS232C board.

Has the problem been resolved?

Yes End of procedure.

No Contact Technical Support.

No Replace the main control board.

Has the problem been resolved?

Yes End of procedure.

No Contact Technical Support.

This page was intentionally left blank

4.8 PRINTER TESTS

4.8.01 General Information

This section covers the tests listed below.

- Rolling ASCII Test
- Font Test
- Serial Interface Loopback Test
- Hexadecimal Dump Mode

The Rolling ASCII and Font Tests check print operations.

The Serial Interface Loopback Test checks the operation of the serial interface board.

The Hexadecimal Dump Mode checks the data transfer between the computer and printer.

4.8.02 Rolling ASCII Test

General Information

The rolling ASCII test is a continuous printout of all 96 ASCII characters.

Use this test to check the following items.

1. Print Quality
 - Across the entire length of a line
 - Down the entire page
2. Line Spacing
3. Left Margin Alignment

At the top of the test is the printer type (1), emulation (2), country (3), and firmware revision level (4). This information is often required while performing service or when contacting Okidata. Have this test available during your service call.

CAUTION

Before running this test, make sure that continuous feed paper is loaded.

If you are running this test on a Microline 591, use wide paper or have the page width set for 8.5" x 11" in the printer menu.

Running the test without paper loaded or having the wrong width paper loaded will allow the printhead to print on the platen. This will dirty the platen, cause excessive wear on the ribbon, and may damage the platen, ribbon, and printhead.

Procedure

Follow these steps to print the Rolling ASCII Test.

1. Load the correct size continuous feed paper.
2. Power off the printer.
3. Press and hold the QUIET switch while powering on the printer. You must hold the QUIET switch until the test starts to print.
4. The test will continue to print until you press the SEL switch or run out of paper.

4.8.03 Font Test

General Information

The font test is a one page sample printout of each available typeface.

10 cpi Letter Quality Courier

10 cpi Letter Quality Roman

10 cpi Letter Quality Swiss

10 cpi Letter Quality Orator

10 cpi Letter Quality Gothic

10 cpi Letter Quality Prestige

10 cpi Utility

18 point Letter Quality Swiss

12 cpi Letter Quality Superscript/Subscript

At the top of the test is the printer type (1), emulation (2), country (3), and firmware revision level (4). This information is often required while performing service or when contacting Okidata. Have this test available during your service call.

CAUTION

Running the test without paper loaded will allow the printhead to print on the platen. This will dirty the platen, cause excessive wear of the ribbon, and may damage the platen, ribbon, and printhead.

Procedure

Follow these steps to print the font test.

1. Load the paper.
2. Power off the printer.
3. Press and hold the LF switch while powering on the printer. You must hold the LF switch until the test starts to print.
4. The one page test will print, then stop.

Sample

1 2 3 4

ML590 EY A F/W 01.22 YR4084-8066-83
CG 01.02

```
LQ Courier 10CPI
! "$%&'()*+,-./0123456789:;<=>?@ABCDEFGHIJKLMNopqrstuvwxyz[\]^_`abcdefghijklmnopqrstu
vwxyz{|}~ !"#$%&'()*+,-./0123456789:;<=>?@ABCDEFGHIJKLMNopqrstuvwxyz[\]^_`
abcdefghijklmnopqrstu vwxyz{|}~ !"#$%&'()*+,-./0123456789:;<=>?@ABCDEFGHIJKLMNO
PQRSTUVWXYZ[\]^_`abcdefghijklmnopqrstu vwxyz{|}~

LQ Roman 10CPI
! "$%&'()*+,-./0123456789:;<=>?@ABCDEFGHIJKLMNopqrstuvwxyz[\]^_`abcdefghijklmnopqrstu
vwxyz{|}~ !"#$%&'()*+,-./0123456789:;<=>?@ABCDEFGHIJKLMNopqrstuvwxyz[\]^_`
abcdefghijklmnopqrstu vwxyz{|}~ !"#$%&'()*+,-./0123456789:;<=>?@ABCDEFGHIJKLMNO
PQRSTUVWXYZ[\]^_`abcdefghijklmnopqrstu vwxyz{|}~

LQ Swiss 10CPI
! "$%&'()*+,-./0123456789:;<=>?@ABCDEFGHIJKLMNopqrstuvwxyz[\]^_`abcdefghijklmnopqrstu
vwxyz{|}~ !"#$%&'()*+,-./0123456789:;<=>?@ABCDEFGHIJKLMNopqrstuvwxyz[\]^_`
abcdefghijklmnopqrstu vwxyz{|}~ !"#$%&'()*+,-./0123456789:;<=>?@ABCDEFGHIJKLMNO
PQRSTUVWXYZ[\]^_`abcdefghijklmnopqrstu vwxyz{|}~

LQ Orator 10CPI
! "$%&'()*+,-./0123456789:;<=>?@ABCDEFGHIJKLMNopqrstuvwxyz[\]^_`abcdefghijklmnopqrstu
vwxyz{|}~ !"#$%&'()*+,-./0123456789:;<=>?@ABCDEFGHIJKLMNopqrstuvwxyz[\]^_`
abcdefghijklmnopqrstu vwxyz{|}~ !"#$%&'()*+,-./0123456789:;<=>?@ABCDEFGHIJKLMNO
PQRSTUVWXYZ[\]^_`abcdefghijklmnopqrstu vwxyz{|}~

LQ Gothic 10CPI
! "$%&'()*+,-./0123456789:;<=>?@ABCDEFGHIJKLMNopqrstuvwxyz[\]^_`abcdefghijklmnopqrstu
vwxyz{|}~ !"#$%&'()*+,-./0123456789:;<=>?@ABCDEFGHIJKLMNopqrstuvwxyz[\]^_`
abcdefghijklmnopqrstu vwxyz{|}~ !"#$%&'()*+,-./0123456789:;<=>?@ABCDEFGHIJKLMNO
PQRSTUVWXYZ[\]^_`abcdefghijklmnopqrstu vwxyz{|}~

LQ Prestige 10CPI
! "$%&'()*+,-./0123456789:;<=>?@ABCDEFGHIJKLMNopqrstuvwxyz[\]^_`abcdefghijklmnopqrstu
vwxyz{|}~ !"#$%&'()*+,-./0123456789:;<=>?@ABCDEFGHIJKLMNopqrstuvwxyz[\]^_`
abcdefghijklmnopqrstu vwxyz{|}~ !"#$%&'()*+,-./0123456789:;<=>?@ABCDEFGHIJKLMNO
PQRSTUVWXYZ[\]^_`abcdefghijklmnopqrstu vwxyz{|}~

Utility 10CPI
! "$%&'()*+,-./0123456789:;<=>?@ABCDEFGHIJKLMNopqrstuvwxyz[\]^_`abcdefghijklmnopqrstu
vwxyz{|}~ !"#$%&'()*+,-./0123456789:;<=>?@ABCDEFGHIJKLMNopqrstuvwxyz[\]^_`
abcdefghijklmnopqrstu vwxyz{|}~ !"#$%&'()*+,-./0123456789:;<=>?@ABCDEFGHIJKLMNO
PQRSTUVWXYZ[\]^_`abcdefghijklmnopqrstu vwxyz{|}~

LQ Swiss 18Point
! "$%&'()*+,-./0123456789:;<=>?@ABCDEFGHI
HIJKLMNopqrstuvwxyz[\]^_`abcdefghijklmnop
pqrstuvwxyz{|}~ !"#$%&'()*+,-./012345678
9:;<=>?@ABCDEFGHIJKLMNopqrstuvwxyz[\]^_`
abcdefghijklmnopqrstu vwxyz{|}~

LQ Super/Sub 12CPI
! "$%&'()*+,-./0123456789:;<=>?@ABCDEFGHIJKLMNopqrstuvwxyz[\]^_`abcdefghijklmnopqrstu
vwxyz{|}~ !"#$%&'()*+,-./0123456789:;<=>?@ABCDEFGHIJKLMNopqrstuvwxyz[\]^_`
abcdefghijklmnopqrstu vwxyz{|}~ !"#$%&'()*+,-./0123456789:;<=>?@ABCDEFGHIJKLMNO
PQRSTUVWXYZ[\]^_`abcdefghijklmnopqrstu vwxyz{|}~
```

4.8.04 Serial Interface Loopback Test

NOTE:

In order to run this test, the serial interface board must be installed with a serial loopback test connector attached to it.

To perform the serial interface loopback test, follow these steps.

1. Place the printer in the Serial Diagnostic mode.

Set the Diagnostic Test menu item to YES.

2. Power off the printer.
3. Attach the loopback connector to the serial port.
4. Install continuous feed paper.
5. Power on the printer.
6. The message LOOP TEST will be printed.
7. The size of the Message Buffer will be printed.
8. Three different messages may be printed next.

If the message **OK** is printed next, the message buffer has been tested and no problems were found.

If the message **BAD** is printed next, there is a problem with the message buffer.

If the message **IF BAD** is printed, the signal logic was tested and a problem was found.

9. Hexadecimal characters 20 through 7F are transmitted through the transmit data line.
10. The receive data line receives the characters.
11. The message buffer then stores the characters.
12. The data is then printed.
13. The test will run until the printer is powered off or the SELECT switch is pressed.

Loopback Connector Configuration

1. Jumper the following pins together:

Pin 2 to Pin 3

Pin 4 to Pin 5

Pin 8 to Pin 11

Pin 6 to Pin 20

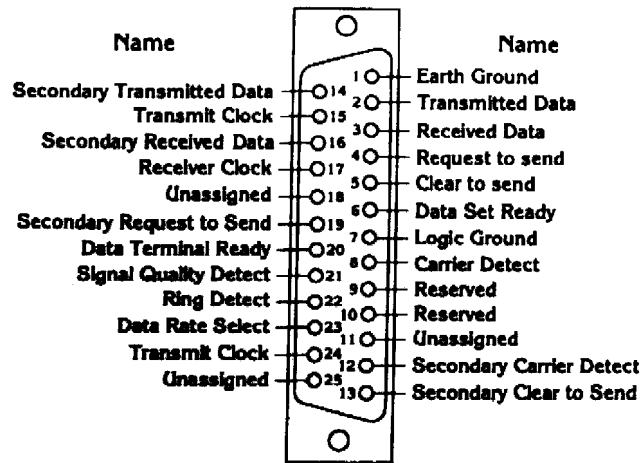

RS232-C Serial Loopback Test Connector

(DB25P Plug)

4-8-04.tif

Serial Cable Information

The information in this section will help you make a serial cable to connect between the printer and computer.

Refer to the computer documentation to determine the cable requirements on the computers end.

The printer has the following cable requirements.

- Shielded, RS-232C cable
- UL and CSA approved
- No more than 50 feet long
- Cannon DB-25P plug (or equivalent) with 25 pins
- Cannon DB-C2-J9 (or equivalent) connector shell

Serial Interface Signal Requirements

Pin	Signal	Symbol	Direction	Description
1	Protective Ground	PG	Ground	Connected to the printer frame
2	Transmit Data	TD	From Printer	Serial data transmitted to the system
3	Receive Data	RD	To Printer	Serial data received by the printer
4	Request to Send	RTS	From Printer	Always set to low (mark)
5	Not Used			
6	Data Set Ready	DSR	To Printer	Indicates that data can be sent
7	Signal Ground	SG	Ground	Ground
8 to 10	Not Used			
11	Supervisory Send Data	SSD	From Printer	Indicates that the printer is not ready to receive data
12 to 19	Not Used			
20	Data Terminal Ready	DTR	From Printer	Indicates that the printer is not ready to receive data
21 to 25	Not Used			

Commonly Used Serial Cable Configurations

IBM 25-Pin Cable Configuration

Computer		Printer	
PG	1	1	PG
TD	2	3	RD
RD	3	2	TD
CTS	5	11	SSD
DSR	6	20	DTR
		6	DSR
SG	7	7	SG
		4	RTS
		5	CTS

IBM 9-Pin Cable Configuration

Computer		Printer	
RD	2	2	TD
TD	3	3	RD
SG	5	7	SG
DSR	6	20	DTR
		6	DSR
CTS	8	11	SSD
		4	RTS
		5	CTS

4.8.05 Hexadecimal Dump Mode

General Information

The hexadecimal dump mode allows you to view the data sent from a computer to the printer. When the printer is in hex dump mode, all data received (both printable characters and control codes) will be printed in both hexadecimal and ASCII format.

NOTE:

In the ASCII format, all non-printable characters will be represented by a period.

Example

Below is a line of BASIC code.

```
LPRINT CHR$(27) ;"0";CHR$(30);"This is an example of hexadecimal dump."
```

Below is the same line as it would appear in Hexadecimal Dump Mode.

1B 30 1E 54 68 69 73 20 69 73 20 61 6E 20 65 78 .0.	This is an ex
61 6D 70 6C 65 20 66 20 61 20 68 65 78 61 64	ample of a hexad
65 63 69 6D 61 6C 20 64 75 6D 70 2E 0D 0A	ecimal dump

Procedure

Follow these steps to engage the Hexadecimal Dump Mode.

1. Make sure the printer is connected to a computer.
2. Verify that paper is loaded.
3. Verify that the ribbon and printhead are correctly installed.
4. Power OFF the printer.
5. Press and hold the SEL and FF/LOAD switches while powering on the printer.
6. Hold the switches until the printer prints the line:

Hex Data Dump

7. The printer is ready to receive data in the Hexadecimal Dump Mode.
8. Send data to the printer from the computer.
9. To exit Hexadecimal Dump Mode, power OFF the printer.

Sample

Hex	Data	Dump
1B 7B 42 1B 74 01 1B 49 01 1B 36 1B 52 00 1B 78		.[B.t.I..6.R..x
01 1B 19 30 1B 43 00 0B 0D 1B 4A A2 1B 24 3C 00		...0.C....J[.3<
1B 72 00 1B 55 01 1B 2A 27 49 03 00 00 30 00 00		-r..U..*!I...0..
30 00 00 30 00 00 30 00 00 30 00 00 30 00 00 3F		0..0..0..0..0..?
00 00 3F 00 00 30 00 00 30 00 00 30 00 00 30 00		..?.0..0..0..0..
00 30 00 00 30 00 00 30 00 00 30 00 00 3F 00 00		..0..0.....?..
3F 00 00 00 00 00 00 00 00 01 00 00 01 00 00 01		?.....
00 00 01 00 00 00 00 00 00 00 00 00 00 00 00 00	
00 00 00 00 00 00 00 00 00 00 00 00 00 00 00 00	
01 00 00 01 00 00 01 00 00 01 00 00 01 00 00 00	
00 00 00 00 00 00 00 00 00 00 00 00 00 00 00 00	
00 00 00 00 00 00 00 00 00 00 00 00 00 00 00 00	
00 00 00 00 00 00 00 00 00 3F 00 00 3F 00 00 1F	?.?.0..
00 00 07 00 00 00 00 00 00 00 00 00 00 00 00 00	
00 00 00 00 00 00 00 00 00 00 07 00 00 1F 00 00	
3B 00 00 3F 00 00 3F 00 00 00 00 00 00 00 00 00		0..?..?.....
00 00 00 00 00 31 00 00 31 00 00 00 00 00 00 00	1..1.....
00 00 00 00 00 00 00 00 00 00 00 00 00 01 00 00	
01 00 00 01 00 00 01 00 00 01 00 00 01 00 00 00	
00 00 00 00 00 00 00 00 00 00 00 00 00 00 01 00	
00 01 00 00 00 00 00 00 01 00 00 01 00 00 01 00 00	
00 00 00 00 00 00 00 00 00 00 00 00 01 00 00 01	
00 00 01 00 00 01 00 00 01 00 00 01 00 00 00 00	
00 00 00 00 00 00 00 00 00 00 00 00 00 00 00 00	
3F 00 00 3F 00 00 00 00 00 00 00 00 00 00 00 00		7..?.?.....
00 00 31 00 00 31 00 00 00 00 00 00 00 00 00 00		..1..1.....
00 00 00 00 01 00 00 01 00 00 00 00 00 00 00 00	
01 00 00 01 00 00 01 00 00 01 00 00 00 00 00 00	
00 00 00 00 00 00 00 00 00 00 00 00 00 00 00 00	
00 00 00 00 00 00 00 00 01 00 00 01 00 00 01 00 00	
01 00 00 01 00 00 01 00 00 01 00 00 00 00 00 00	
00 00 00 00 00 00 00 00 00 00 00 00 00 00 00 00	
00 00 00 00 00 00 00 00 00 00 00 00 00 00 00 00	
2B 00 00 00 00 00 00 00 00 00 00 00 00 0F 00 00	
3F 00 00 30 00 00 30 00 00 30 00 00 30 00 00 30		7..0..0..0..0..0
00 00 30 00 00 30 00 00 30 00 00 00 00 00 00 00		..0..0..0.....
00 00 00 00 00 00 00 00 0F 00 00 1C 00 00 30 00 00	0..
30 00 00 30 00 00 30 00 00 30 00 00 10 00 00 1C		0..0..0..0.....
00 00 0F 00 00 03 00 00 00 00 00 00 00 00 03 00	0..0..0..
00 0F 00 00 1C 00 00 30 00 00 30 00 00 30 00 00	0..0..0..
30 00 00 30 00 00 30 00 00 1C 00 00 0F 00 00 03		0..0..0.....
00 00 00 00 00 00 00 00 00 00 00 00 00 00 01 00	
00 0F 00 00 3F 00 00 30 00 00 00 00 00 00 00 00	?.0.....
0F 00 00 3F 00 00 30 00 00 30 00 00 30 00 00 30		..7..0..0..0..0
0E 00 30 00 00 30 00 00 30 00 00 30 00 00 00 00		..0..0..0..0.....
00 00 00 00 00 00 00 00 07 00 00 0F 00 00 1C 00 00	
3B 00 00 30 00 00 30 00 00 30 00 00 30 00 00 10		0..0..0..0..0..0
00 00 1C 00 00 0F 00 00 03 00 00 00 00 00 00 00	
00 00 00 00 03 00 00 03 00 00 07 00 00 0E 00 00	
0C 00 00 3F 00 00 3F 00 00 00 00 00 00 00 00 00		...?.?.?.....
00 00 00 00 00 00 00 00 00 00 00 00 00 00 00 00	
00 00 00 00 00 00 00 00 00 00 00 00 00 00 00 00	

4.9 RESISTANCE CHECKS

4.9.01 General Description

The charts on the following pages provide information needed to determine if the printhead and motors used in the printer are defective.

NOTE:

The printhead coil resistance values ARE NOT LISTED.

The individual printwire control lines CANNOT be accessed on this printhead.

Layout Diagram

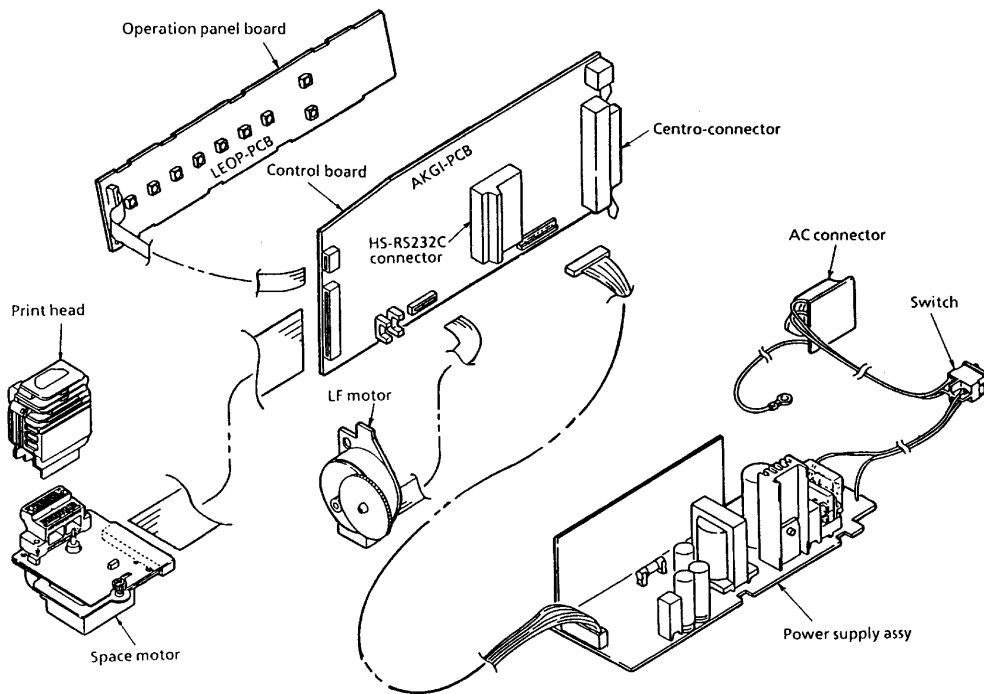

4-6-01a.pcx

4.9.02 Printhead

Interconnect Diagram: Control Board to Printhead

NOTE:

The printhead coil resistance values ARE NOT LISTED.

The individual printwire control lines CANNOT be accessed on this printhead.

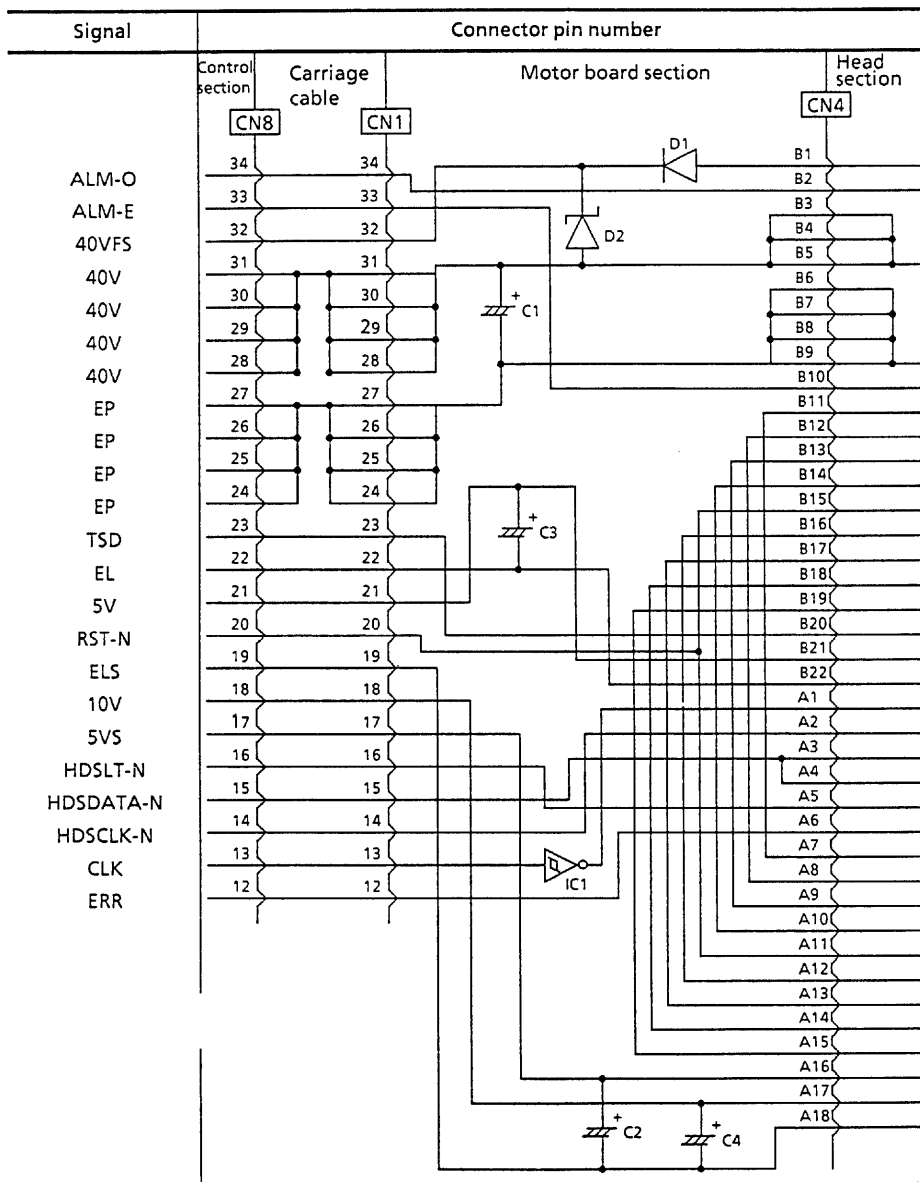

4-9-02.pcx

4.9.03 Line Feed Motor Resistance

The resistance of each coil should be approximately 13 ohms.

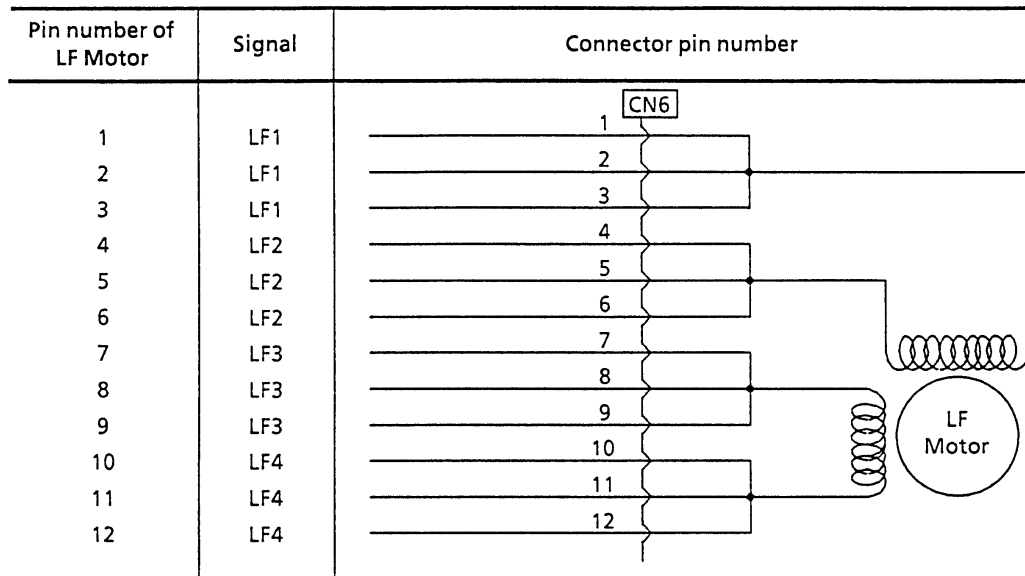

4-9-03.pcx

4.9.04 Space Motor Resistance

The resistance of each coil should be approximately 5 ohms.

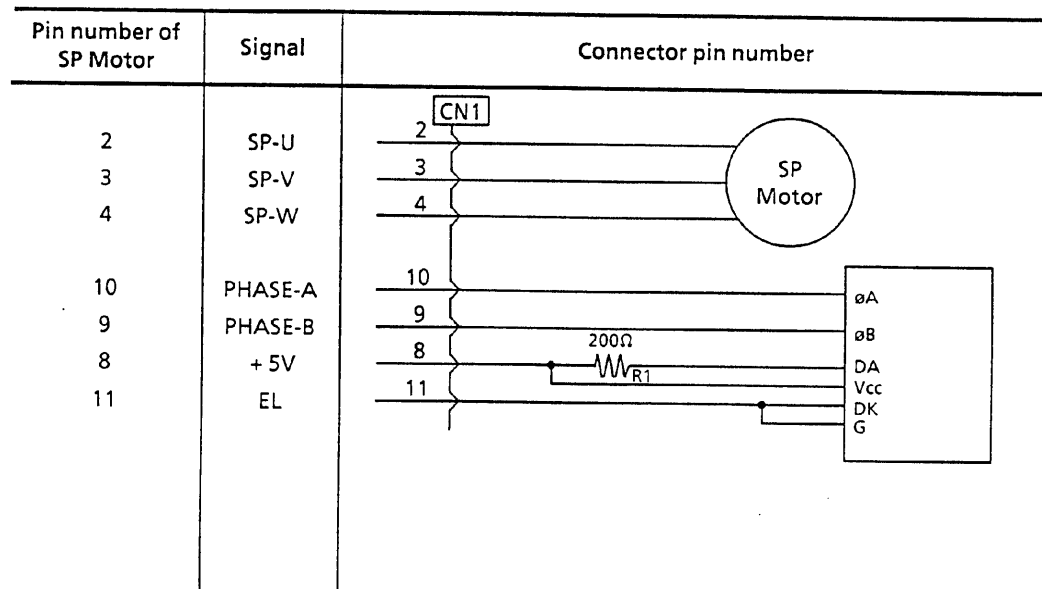

4-9-04.pcx

This page was intentionally left blank.

APPENDIX A
BOARD DIAGRAMS

A.1 OVERVIEW

A.1.01 General Information

This section describes the characteristics of the printed circuit boards (PCBs) used in the printer.

The following areas are covered.

Firmware

Fuses

Jumpers

Sensors

Switches

Test Points

Where an item is not applicable, the word *NONE* will be listed.

A.2 INDEX TO CHARTS

Description	Board Designation	Section
Main Controller Board	AKGI	A.2.01
Operator Panel Board	LEOP	A.2.02
Power Supply Assembly	N/A	A.2.03
Space Motor PCB	N/A	A.2.04
RS232-C Serial Interface Board	LXHI	A.2.05

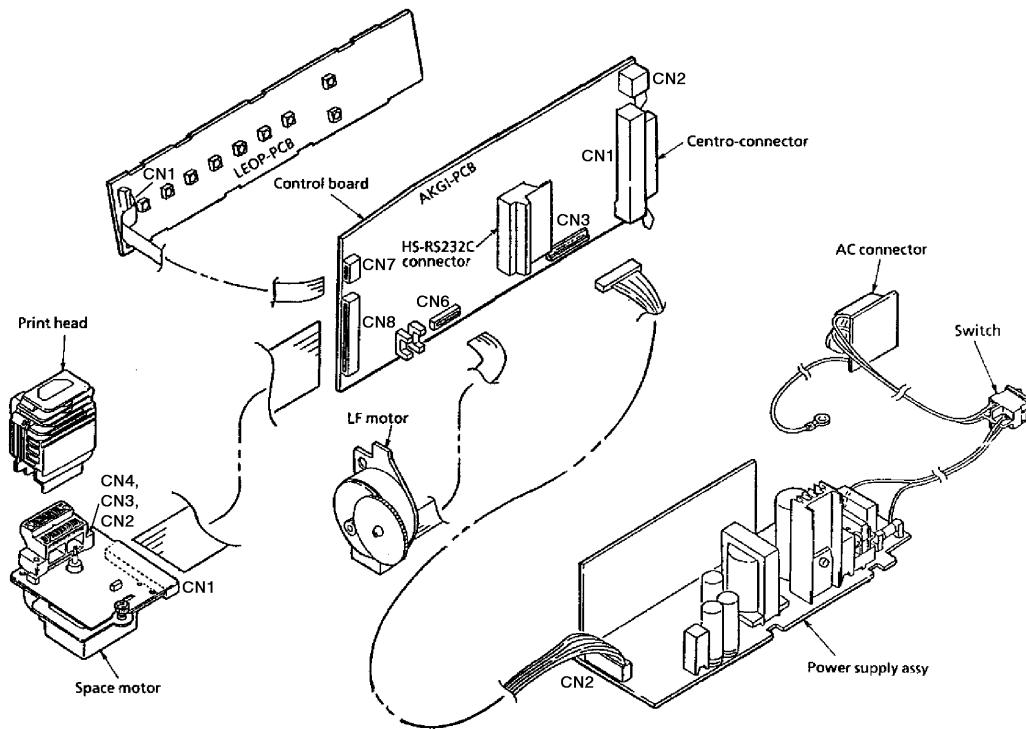

A-2-00.pcx

A.2.01 Main Controller Board (AKGI)

Firmware

05C: CG ROM (Character Generator)

05D: EPROM (Printer Control Program)

NOTE:

If a 4 Mbit Masked ROM is in location 05D, there SHOULD NOT be a ROM in location 05C.

However, make sure that jumper SP1 is placed on the A Side.

Fuses

F1: soldered - 1 amp. (protects the +40 vdc motor drive circuit)

Jumpers

SP1: EPROM Address Select Jumper

A Side: 4 Mbit Masked ROM is in location 05D

B Side: CGROM (Location 05C) and EPROM (Location 05D) are installed

Sensors

SNS1: Rear / Top Feed Paper Out Sensor

SNS3: Bottom Feed Paper Out Sensor

Switches

BASW: Paper Path Select Switch

Test Points

+5 vdc: (Logic, LED Drive Voltage) CN3 - Pins 5 and 6

- 8 vdc: (Serial Interface Line Voltage) CN3 - Pin 11

+8 vdc: (Serial Interface Line Voltage, Comparator Voltage) CN3 - Pin 10

+12 vdc: (Printhead Analog Voltage) CN3 - Pin 9

+40 vdc: (Printhead, Space Motor / Line Feed Motor Drive Voltage) CN3 - Pins 1 and 2

Frame Ground: CN3 - Pins 3 and 4

Logic Ground: CN3 - Pins 7 and 8

ALM: (Alarm Signal to the Power Supply Board) CN3 - Pin 12

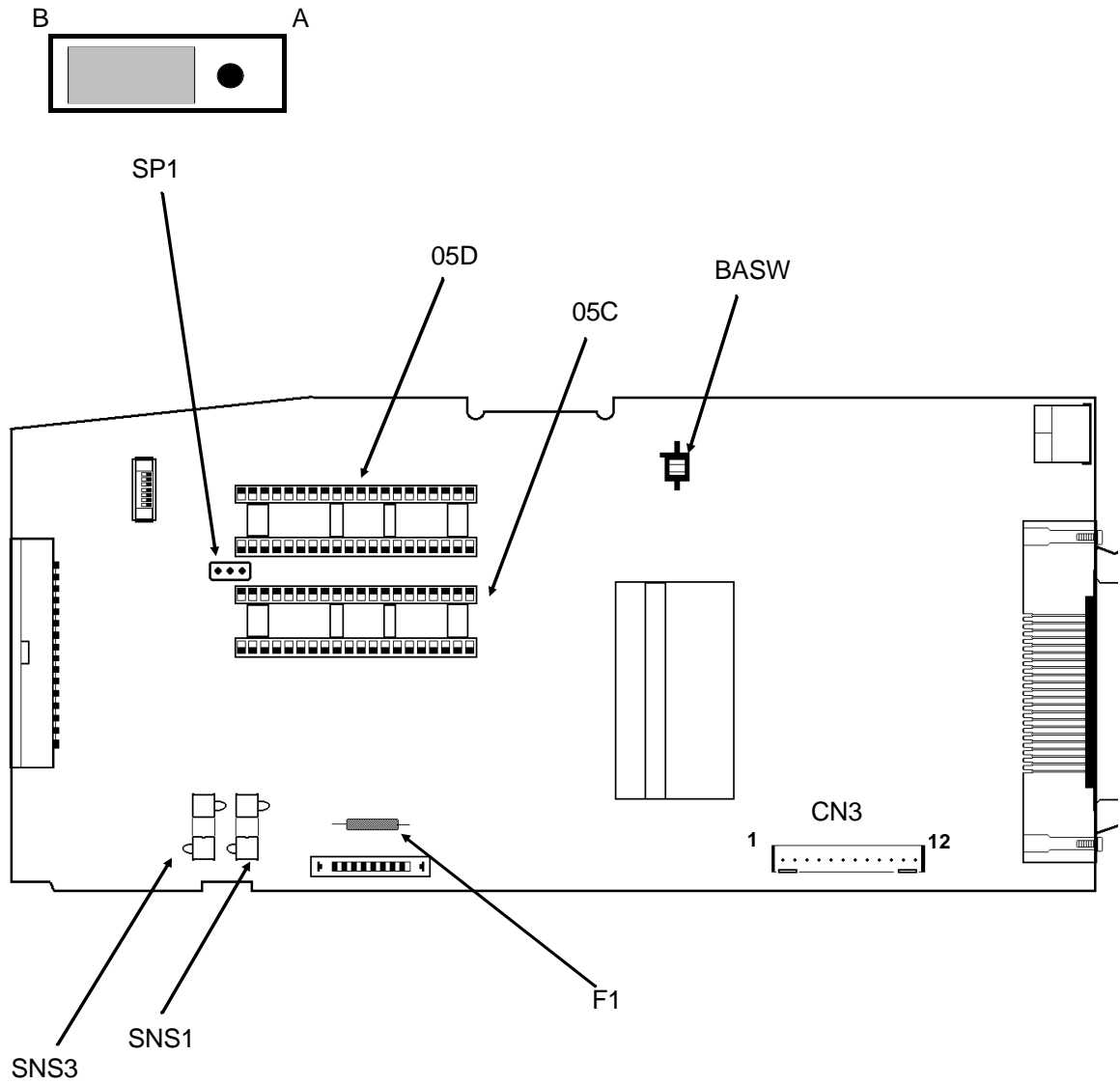

A-2-01.pcx

A.2.02 Operator Panel Board (LEOP)

Firmware

NONE

Fuses

NONE

Jumpers

NONE

Sensors

NONE

Switches

SEL: (Select)

SHIFT:

LF: (Line Feed)

FF: (Form Feed)

TEAR:

PARK:

QUIET:

PQ: (Print Quality)

CP: (Character Pitch)

Test Points

NONE

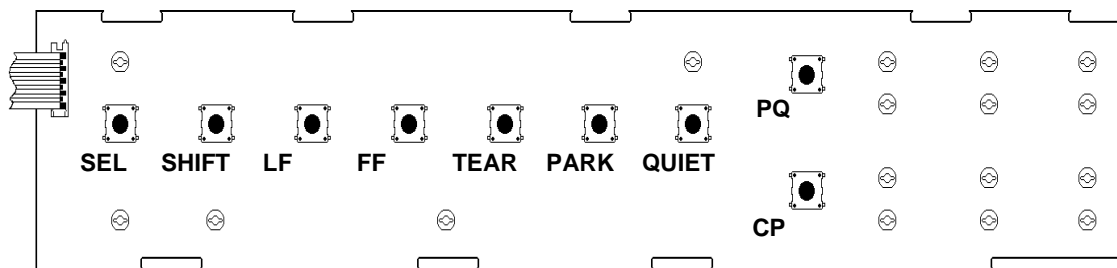

A-2-02.pcx

A.2.03 Power Supply Assembly

Firmware

NONE

Fuses

F1: 125/250V 5 amp. (AC LINE Fuse)

F2: 125/250V 2.5 amp. (Protects +5 vdc circuit)

Jumpers

NONE

Sensors

NONE

Switches

SW: Power Switch

Test Points

+5 vdc: (Logic, LED Drive Voltage) CN2 - Pins 5 and 6

- 8 vdc: (Serial Interface Line Voltage) CN2 - Pin 11

+8 vdc: (Serial Interface Line Voltage, Comparator Voltage) CN2 - Pin 10

+12 vdc: (Printhead Analog Voltage) CN2 - Pin 9

+40 vdc: (Printhead, Space Motor / Line Feed Motor Drive Voltage) CN2 - Pins 1 and 2

Frame Ground: CN2 - Pins 3 and 4

Logic Ground: CN2 - Pins 7 and 8

ALM: (Alarm Signal from Main Control Board) CN2 - Pin 12

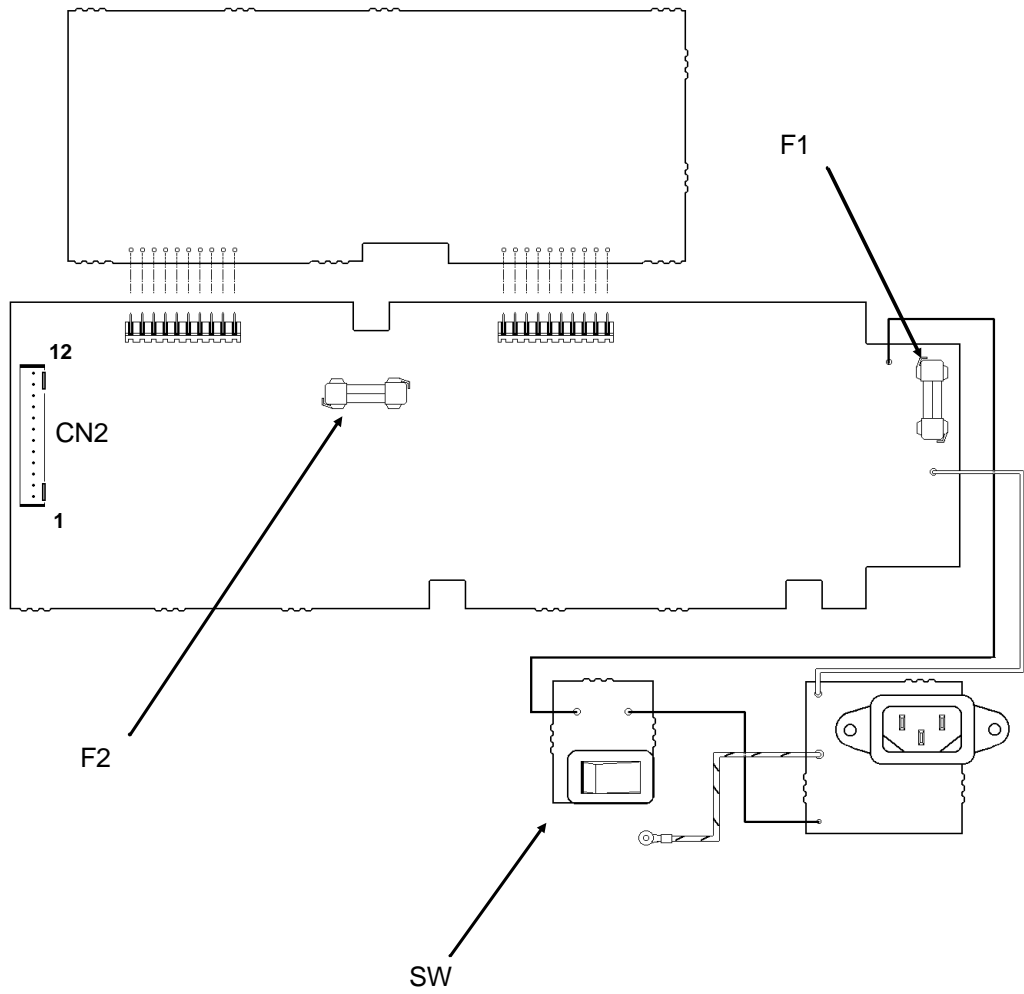

A-2-03.pcx

A.2.04 Space Motor Board

Firmware

NONE

Fuses

NONE

Jumpers

NONE

Sensors

SNS2: Encoder Disk Sensor

Switches

NONE

Test Points

NONE

Connector
(Auto-Gap Mechanism)

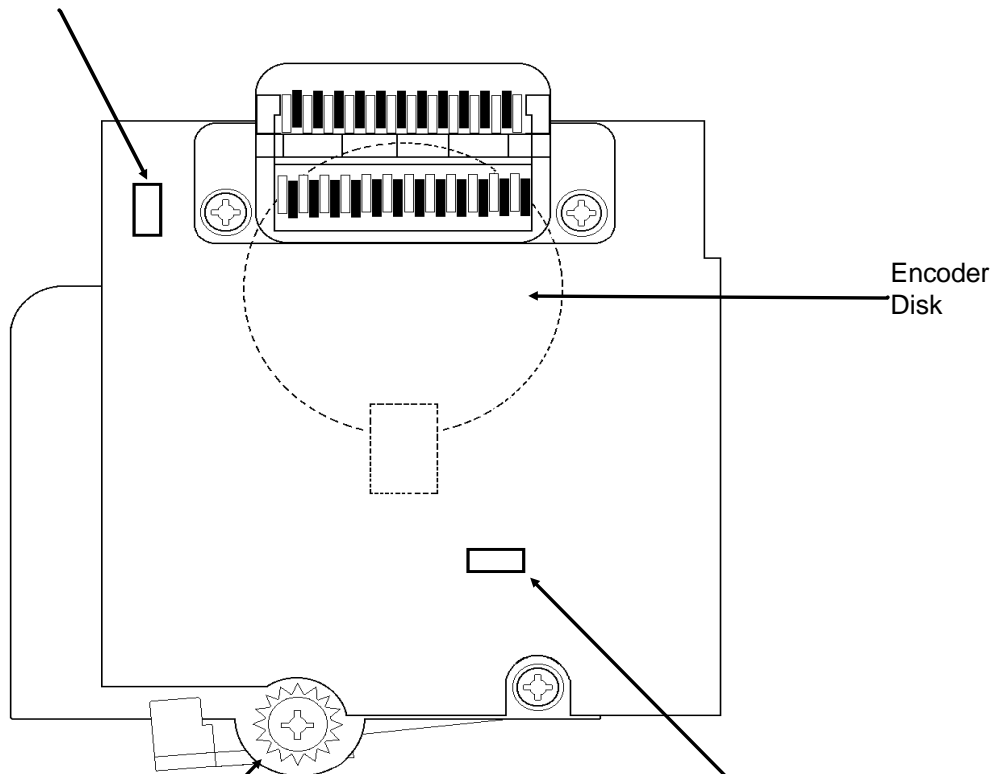

Encoder
Disk

Printhead Gap
Adjusting Screw

Connector
(Color Ribbon
Shift Mechanism)

A-2-04.pcx

A.2.05 RS232-C Serial Interface Board (LXHI) Option

Firmware

Masked to the MPU: Socket is empty

Fuses

NONE

Jumpers

SP1:

EPROM Address Select Jumper (position as shown)

EPROM is masked to MPU

Sensors

NONE

Switches

NONE

Test Points

NONE

Default Setting

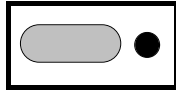

SP1

MPU

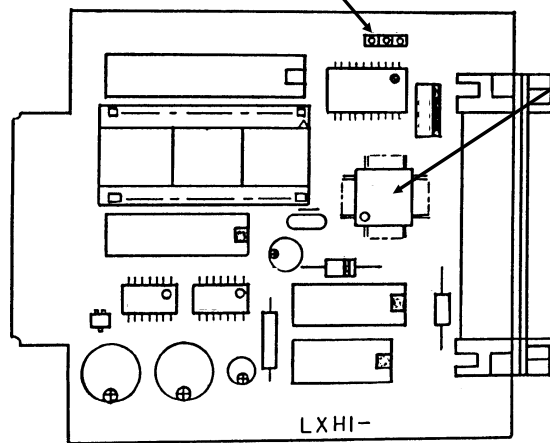

A-2-05.tif

This page was intentionally left blank.

APPENDIX B
ILLUSTRATED PARTS LISTING

B.1 OVERVIEW

B.1.01 General Information

This appendix will assist you in identifying the assemblies and parts of the product.

Use Section Four (Failure Analysis) to determine the defective part(s).

Locate the part and its part number in this section.

Appendix B is cross-referenced to Section Three (Maintenance).

Format

The format for this appendix is a series of tables with diagrams. The tables contain the item reference number, the Okidata and Oki-Japan (Oki-J) part numbers, the part description, a comments section, and the disassembly procedure.

Item	Okidata P/N Oki-J P/N	Description	Comments Refer to B.1.02	Disassembly Procedure
------	--------------------------	-------------	-----------------------------	--------------------------

Items with the comments RSPL (Recommended Spare Parts List), Consumable, Document, or Option are available from Okidata. Items without these comments are usually not stocked.

Some items are only available as assemblies. Every effort has been made to clearly indicate which items are in assemblies and which are not.

N/A will appear where a part number is not available.

Current Part Numbers

Okidata has made every effort to include current part numbers in this Service Handbook *at the time of publishing*.

However, technical information frequently changes. These changes often include new or modified parts, with new or modified part numbers.

Please refer to the following resources for current part numbers and pricing.

- Okidata's Electronic Bulletin Board (Okilink II) contains current part numbers, prices, and recommended stocking levels for each item listed as a recommended spare part. For instructions on accessing Okilink II, refer to the Service Center Reference Guide.
- Okidata's Faxable Facts is an automated fax document retrieval system. Part numbers and pricing are available through Faxable Facts. For instructions on accessing Faxable Facts, refer to the Service Center Reference Guide.
- Okidata's Technical Information Group is a telephone support line reserved for Authorized Dealers. Part numbers and pricing are available through Technical Information. For instructions on accessing Technical Information, refer to the Service Center Reference Guide.

REMEMBER

Current part numbers, recommended stocking levels, and pricing information are available through Okilink II, Faxable Facts, and Technical Information. Refer to the Service Center Reference Guide for information on accessing these resources.

B.1.02 Definition of Terms

Assemblies

Assemblies are parts grouped under a single description and/or part number. Generally, individual items in an assembly are not available from Okidata.

Assemblies are surrounded by broken line boxes in the diagrams.

Assemblies will say "Includes xx xx" under the *Comments* section of the tables.

Parts in assemblies will say "Part of xx" under the *Comments* section of the tables.

Blank

Okidata does not recommend stocking this item. This item should be purchased on an **As Required Basis** *only*.

The availability of this item is *NOT* guaranteed by Okidata.

Consumable

A consumable is a supply item which has a specified life and must be periodically replaced. It is purchased and installed by the end user. Okidata machines are designed to work *exclusively* with Okidata consumables. By using genuine Okidata consumable products, the investment made in the equipment is protected.

Document

A document is a printed item which supports the service and marketing of a product. Various documents are available from Okidata.

Drivers

Printer drivers are updated frequently. Please refer to Okilink II for the latest printer driver information.

Firmware

Firmware is revised frequently. Please refer to Okilink II for the latest firmware information.

Option

An option is a part/assembly which is added to a product. The option expands the product's functionality. An option may or may not be installed by the end user. Instructions for installation accompany each option.

Option RSPL

Okidata recommends that this part/assembly be on hand for servicing installed options.

RSPL

Okidata recommends that this part/assembly be on hand for servicing.

Technical Service Bulletins

Technical Service Bulletins (TSBs) are also referred to as Okidata's monthly mail.

The TSBs contain the latest information on firmware revisions, procedure changes, and technical information updates.

Okidata distributes the TSBs through Okilink II. The TSBs are issued monthly.

590

This part is specific to the Microline 590 printer.

591

This part is specific to the Microline 591 printer.

Both

This part is used by both the Microline 590 and Microline 591 printers.

B.1.03 Parts Ordering Information

Service Center Reference Guide

When a technician has successfully completed a Service Training Course for a product and the Dealer has become Service Authorized, an information package is provided to the Dealer. The Okidata Service Center Reference Guide outlines the following items.

- Responsibilities of Okidata Service Centers
- Spare parts and consumables information
- Procedures for warranty repairs
- Product Training, Certification, and Authorization
- Product Support information
- Okidata Depot information and services
- Third Party Service information
- Information about Okidata's Customer Information Center
- Okidata Service and Support telephone numbers.

The Service Center Reference Guide contains the procedures to follow for ordering parts. Please *read, understand, and follow* these procedures. Service Authorization for a specific product *must* be obtained before a Dealer can submit warranty claims.

Direct questions regarding the Service Center Reference Guide to Okidata Dealer Service. Refer to the Service Center Reference Guide for information on contacting Okidata.

Placing a Parts Order

All authorized Okidata resellers may order spare parts and consumables for Okidata products. Orders are placed through Okidata's Logistics Department.

Please refer to your Service Center Reference Guide for details on ordering parts.

You should have the following information available *before* you place your order.

- Okidata Dealer Authorization Number
- Okidata Customer Number
- Your Purchase Order Number
- Okidata Part Number(s)

Use this Appendix, Okilink II, Faxable Facts, or contact Okidata Technical Support to find the correct part number. Refer to the Service Center Reference Guide for information on contacting Okidata.

B.2 CHARTS

Below is an index to the illustrated parts breakdown charts.

Section	Description
B.2.01	Printer
B.2.02	Upper Cover Assembly
B.2.03	Printer General Assembly
B.2.04	Printer Unit (1 of 3)
B.2.05	Printer Unit (2 of 3)
B.2.06	Printer Unit (3 of 3)
B.2.07	Carriage Assembly
B.2.08	Options
B.2.09	Option Parts
B.2.10	Consumables
B.2.11	Packing Materials
B.2.12	Documentation
B.2.13	Service Training Kit Revision List

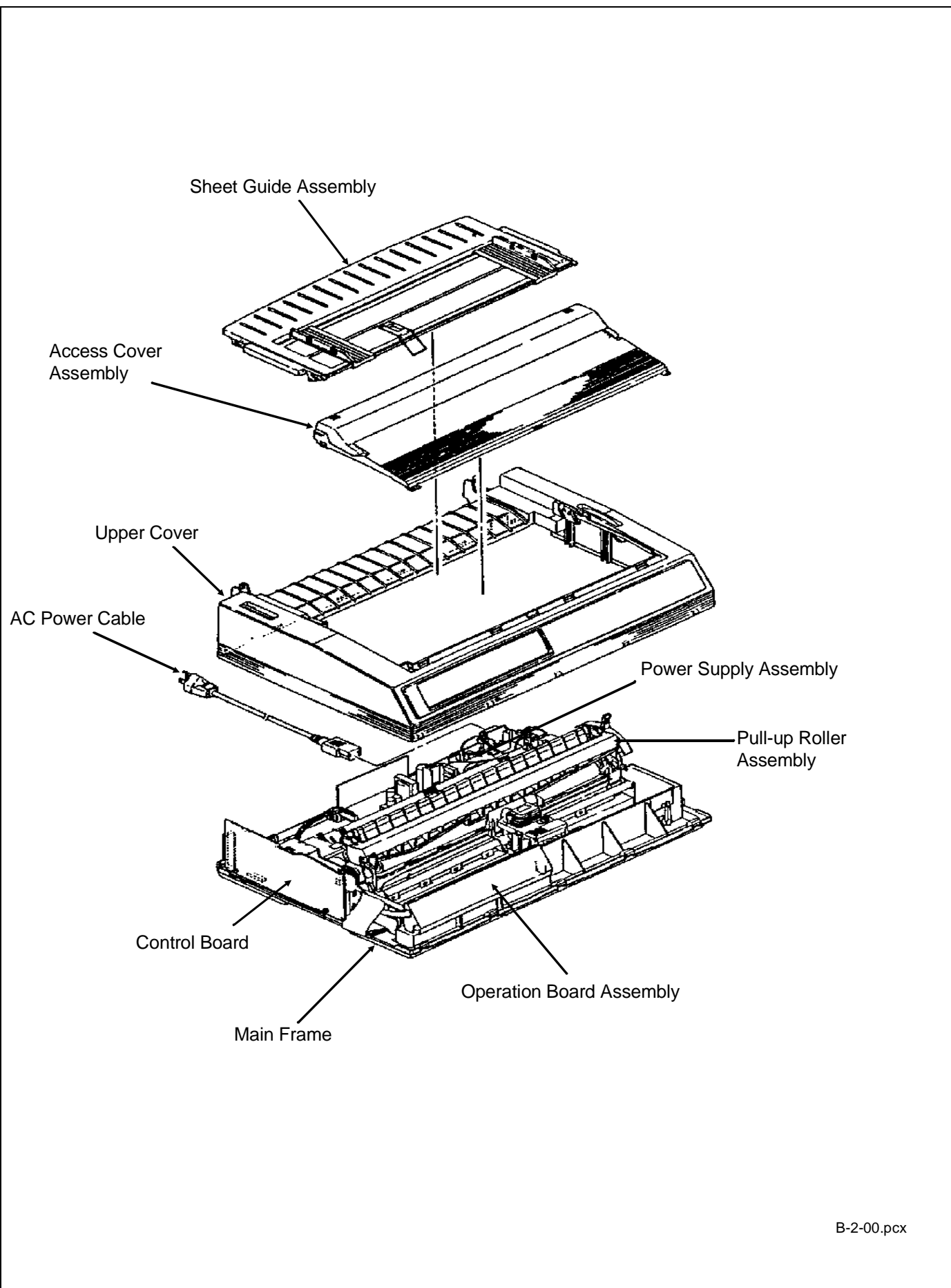

B-2-00.pcx

B.2.01 Printer

Part numbers are subject to change. Refer to Okilink II for current part numbers and pricing information.

Item	Okidata P/N Oki-J P/N	Description	Comments Refer to B.1.02	Disassembly Procedure
1	62409201 N/A	Printer: ML590 Parallel (Epson/IBM Comp.) 120 V		N/A
2	62409202 N/A	Printer: ML590 Parallel (Epson/IBM Comp.) 220 V		N/A
3	62409301 N/A	Printer: ML591 Parallel (Epson/IBM Comp.) 120 V		N/A
4	62409401 N/A	Printer: ML591 Parallel (Epson/IBM Comp.) 220 V		N/A

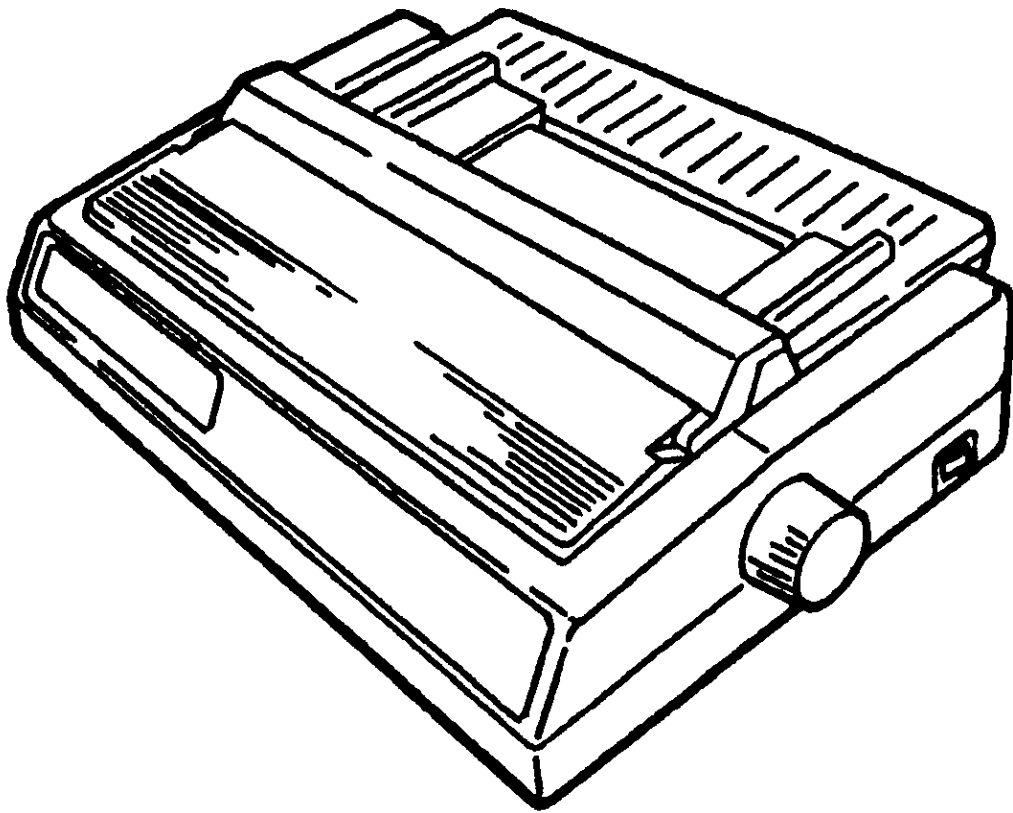

B-2-30.pcx

B.2.02 Upper Cover Assembly

Part numbers are subject to change. Refer to Okilink II for current part numbers and pricing information.

Item	Okidata P/N Oki-J P/N	Description	Comments Refer to B.1.02	Disassembly Procedure
1	53066901 1PP4094-6501P1	Cover: Upper (Narrow)	RSPL 590	3.2.06
1	53067001 1PP4094-7201P1	Cover: Upper (Wide)	RSPL 591	3.2.06
2	51009401 N/A	Guide: Sheet (Narrow)	RSPL 590	3.2.06
2	51009501 N/A	Guide: Sheet (Wide)	RSPL 591	3.2.06
3	53067101 2PA4094-7381G1	Cover: Access (Narrow)	RSPL 590	3.2.06
3	53067201 2PA4094-7382G1	Cover: Access (Wide)	RSPL 591	3.2.06

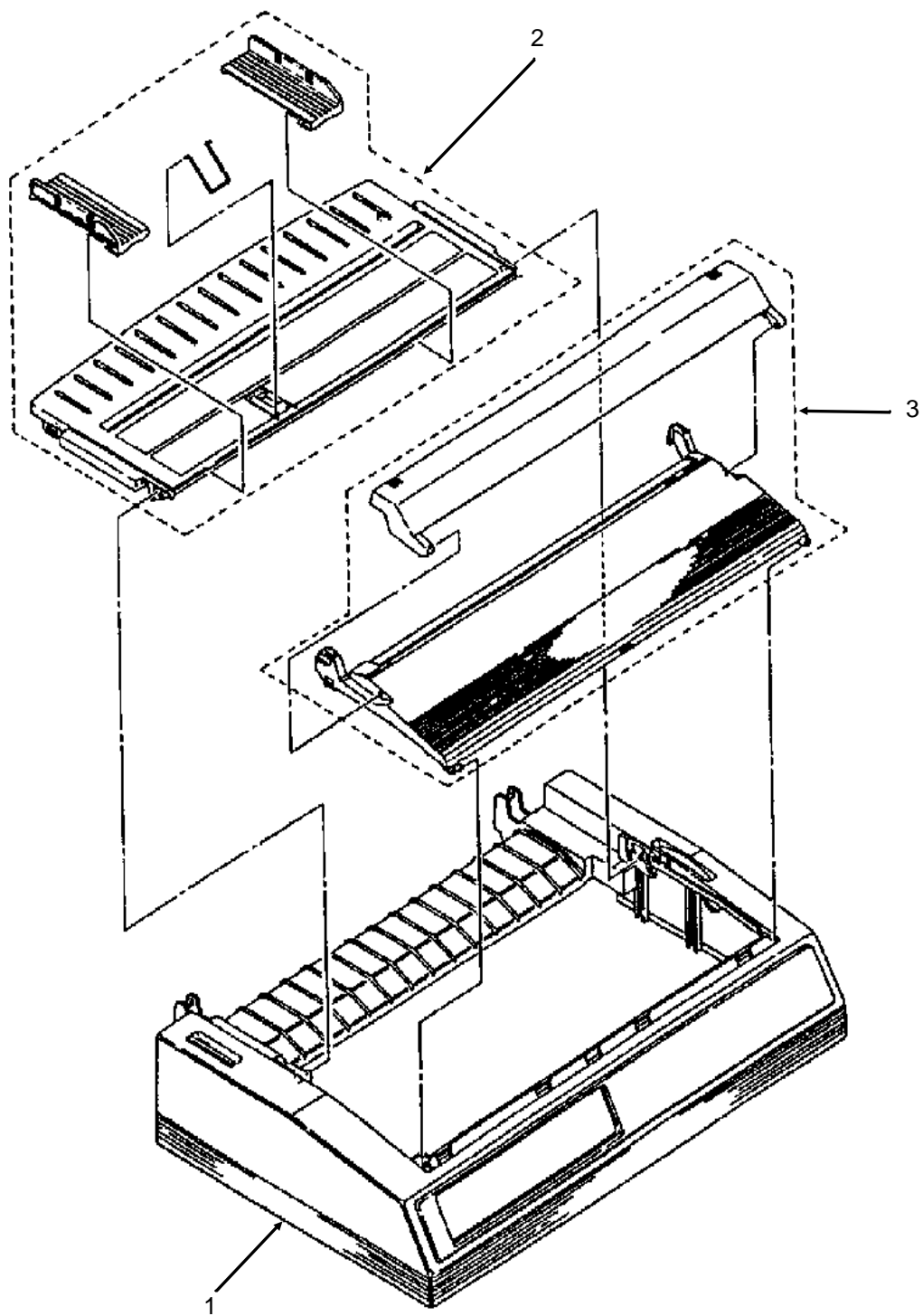

B-2-01.pcx

B.2.03 Printer General Assembly

Part numbers are subject to change. Refer to Okilink II for current part numbers and pricing information.

Item	Okidata P/N Oki-J P/N	Description	Comments Refer to B.1.02	Disassembly Procedure
1	53562601 2PP4094-6507P3	Knob: Platen (ML 500 Series)	RSPL Both	3.2.06
2	53067301 2PP4094-6506P2	Cover: (B) for card slot	RSPL Both	3.2.06
3	55937401 4YA4042-1514G301	PCB: AKGI (w/o ROM)	RSPL Both	3.2.07
4 *	55938301 N/A	IC: EEPROM BR93LC46A	RSPL Both	3.2.07
5	55937501 4YA4042-1516G1	PCB: LEOP (Operator. Panel)	RSPL Both	3.2.09
6	53562701 3PP4025-3670G1	Panel: Operator	RSPL Both	3.2.09
7	56412101 4YB4049-1707P1	Power Supply 120V	RSPL 590	3.2.08
7	56412102 N/A	Power Supply 120V	RSPL 591	3.2.08
7	56412201 4YB4049-1708P1	Power Supply 230-240V	Option RSPL 590	3.2.08
7	56412202 4YB4049-1708P2	Power Supply 230-240V	Option RSPL 591	3.2.08
8	56609701 3YS4011-1315P1	Cord: AC	RSPL Both	3.2.01
9	56624101 3YS4011-1265P1	Cord: AC (220V) (ML) Right Ang	Option RSPL Both	3.2.01
10	56624401 3YS4011-1268P1	Cord: AC 240V	Option RSPL Both	3.2.01
11	50217201 4YA4023-2601G1	Assembly: Printhead	RSPL Both	3.2.02
12	50707501 4PP4025-3621P1	Clamp: Cord	RSPL Both	3.2.08
13	56305901 540A2036M1502	Fuse: (GGS 5) 120V	RSPL Both	3.2.08
13	56306001 4YB4021-1146P1	Fuse: 3.15 A (for 230/240V)	Option RSPL Both	3.2.08
14	56302901 540A2036M1252	Fuse: 2.5A 120V	RSPL Both	3.2.08

* This chip is soldered in on the Main Board, AKGI.

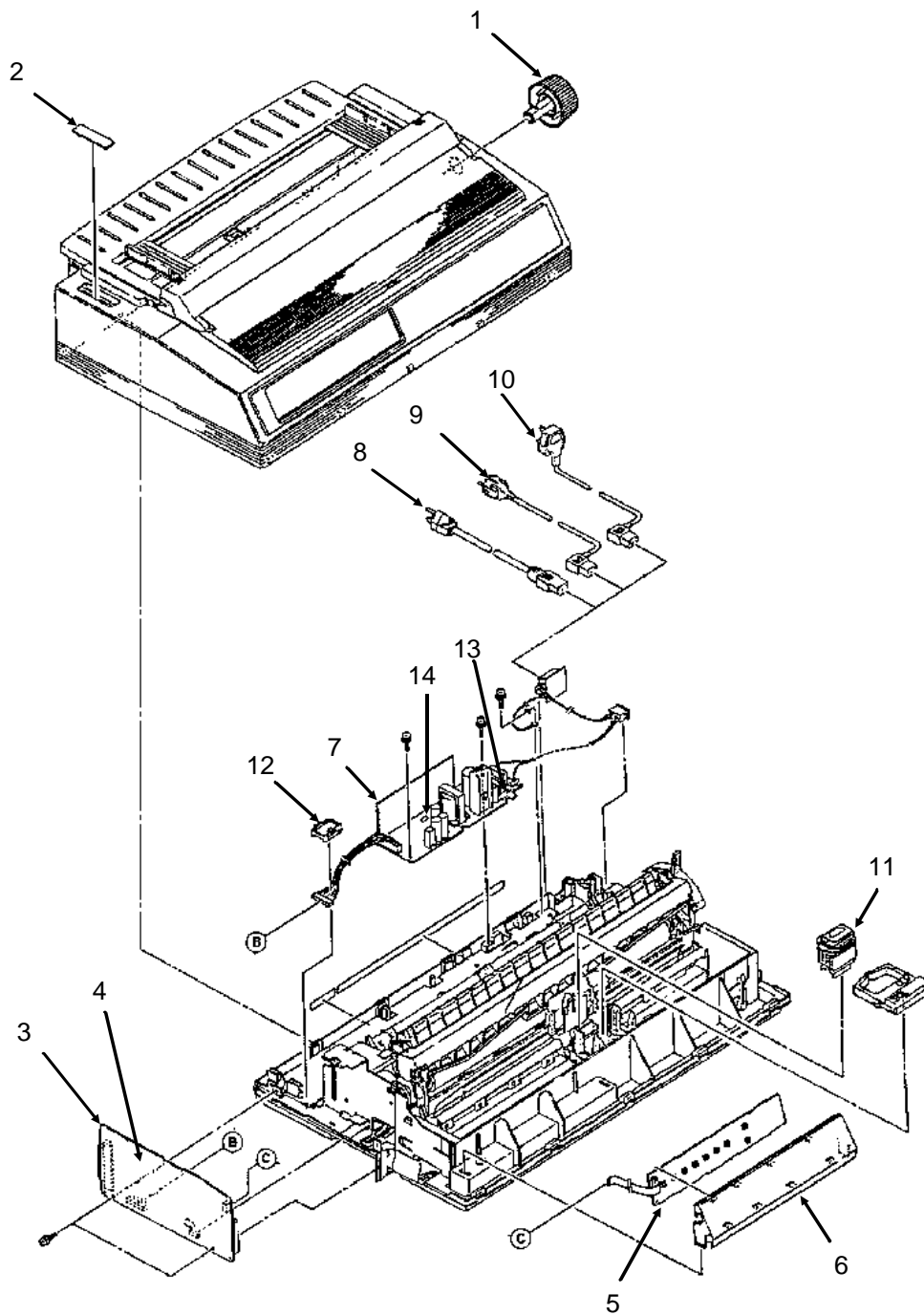

B-2-02.pcx

B.2.04 Printer Unit (1 of 3)

Part numbers are subject to change. Refer to Okilink II for current part numbers and pricing information.

Item	Okidata P/N Oki-J P/N	Description	Comments Refer to B.1.02	Disassembly Procedure
1	53563101 3PA4025-3720G1	Frame: Main (Narrow)	RSPL 590	3.2.30
1	53563201 3PA4025-3721G1	Frame: Main (Wide)	RSPL 591	3.2.30
2	50804601 3PP4025-3315P1	Lever: Bottom Paper End	RSPL Both	3.2.27
3	50804701 3PP4025-3322P1	Lever: Bottom Sensor	RSPL Both	3.2.27
4	50804801 3PP4025-3321P1	Lever: Rear Sensor	RSPL Both	3.2.18
5	50804902 4PP4025-3323P2	Lever: Sensor Cut Sheet/Continuous	RSPL Both	3.2.18
6	56627201 3PB4025-3356P1	Cord: Connection Line Feed	RSPL Both	3.2.21
7	56510301 N/A	Motor: Line Feed (Assembly)	RSPL Both	3.2.21
8	51228401 3PB4055-2887P1	Gear: Line Feed Idle	RSPL Both	3.2.21
9	51010301 3PA4025-3387G1	Plate: Left Ground	RSPL Both	3.2.16
10	50923001 3PP4025-3320P1	Spring: Leaf (Narrow)	RSPL 590	3.2.26
10	50923101 3PP4025-3507P1	Spring: Leaf (Wide)	RSPL 591	3.2.26
11	53067701 3PP4025-3380P1	Cam: Adjust	RSPL Both	3.2.15
12	53563301 3PP4025-3376P1	Rack: Space (Narrow)	RSPL 590	3.2.13
12	53563401 3PP4025-3522P1	Rack: Space (Wide)	RSPL 591	3.2.13
13	50923501 4PB4025-3377P1	Spring: Tension (Space Rack)	RSPL Both	3.2.13
14	51009701 4PP4025-3378P1	Guide: Rail Ground Clip	RSPL Both	3.2.15
15	51009801 3PP4025-3379P1	Guide: Rail (Narrow)	RSPL 590	3.2.15
15	51009901 3PP4025-3523P1	Guide: Rail (Wide)	RSPL 591	3.2.15
16	53563501 4PP4025-3381P1	Shaft: Carriage (Narrow)	RSPL 590	3.2.25
16	53563502 4PP4025-3381P2	Shaft: Carriage (Wide)	RSPL 591	3.2.25
17	53067601 4PA4025-3382G1	Protector: Support (Assembly)	RSPL Both	3.2.25
18	50923601 4PB4025-3385P1	Spring: Support Protect Reset	RSPL Both	3.2.25

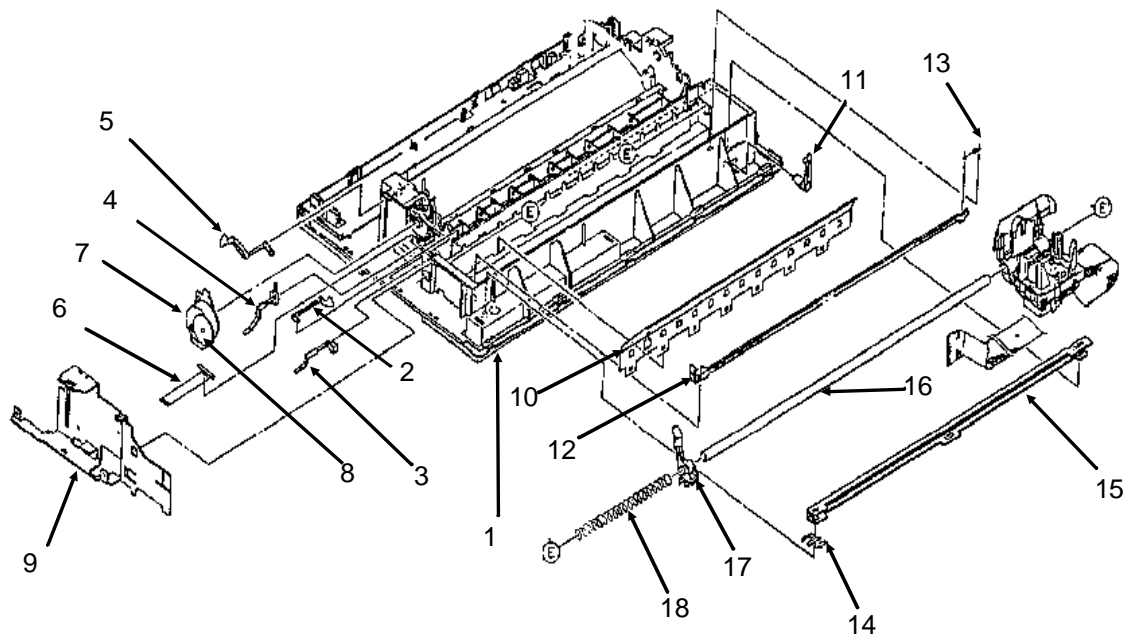

B.2.05 Printer Unit (2 of 3)

Part numbers are subject to change. Refer to Okilink II for current part numbers and pricing information.

Item	Okidata P/N Oki-J P/N	Description	Comments Refer to B.1.02	Disassembly Procedure
1	53563101 3PA4025-3720G1	Frame: Main (Narrow)	RSPL 590	3.2.30
1	53563201 3PA4025-3721G1	Frame: Main (Wide)	RSPL 591	3.2.30
2	51228001 4PP4025-3340P1	Gear: Change	RSPL Both	3.2.29
3	51228101 3PP4025-3341P1	Gear: Tractor	RSPL Both	3.2.29
4	50805301 3PP4025-3352P1	Cam: Release	RSPL Both	3.2.24
5	51228201 4PP4025-3353P1	Gear: Idle	RSPL Both	3.2.23
6	50805101 2PP4025-3354P3	Lever: Change	RSPL Both	3.2.23
7	50923201 3PP4025-3355P1	Spring: Reset	RSPL Both	3.2.22
8	51010201 3PP4025-3386P1	Plate: Right Ground	RSPL Both	3.2.17
9	50098301 3PA4025-3370G1	Platen Assembly (Narrow)	RSPL 590	3.2.19
9	50098302 N/A	Platen Assembly (Wide)	RSPL 591	3.2.19
10	53341501 3PA4025-3440G2	Roller: Pull Up Assembly (Narrow)	RSPL 590	3.2.05
10	53341601 3PA4025-3530G2	Roller: Pull Up Assembly (Wide)	RSPL 591	3.2.05

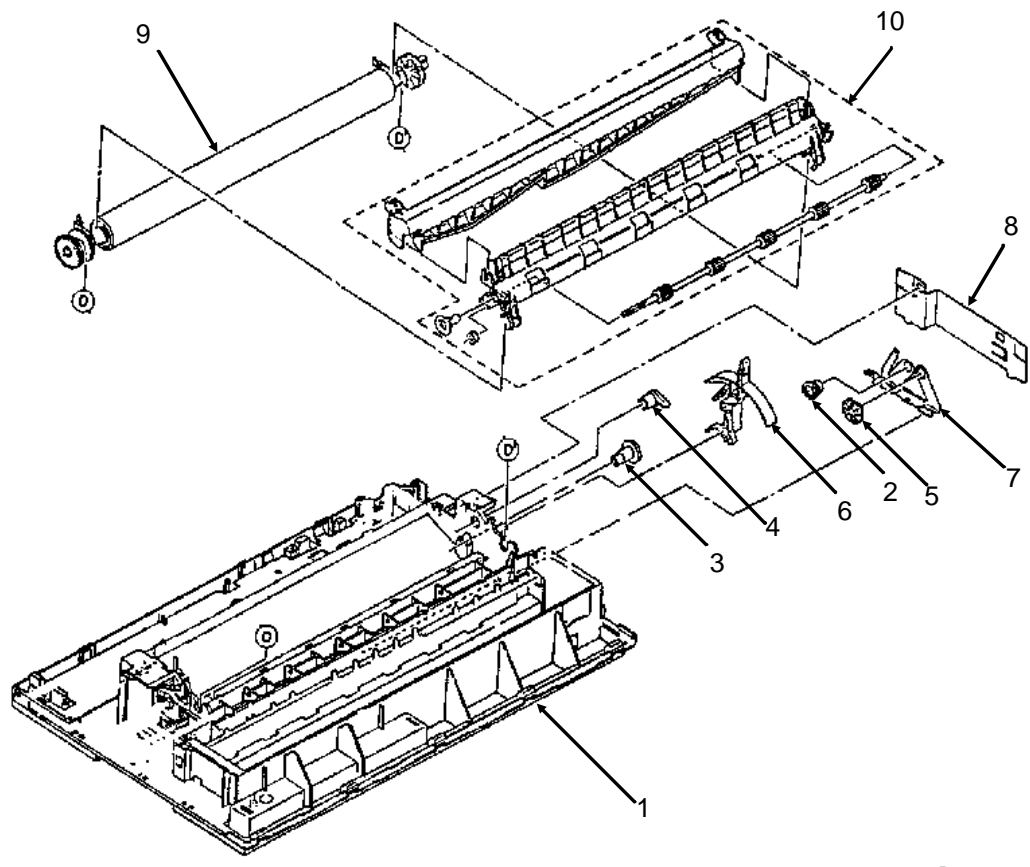

B-2-04.pcx

B.2.06 Printer Unit (3 of 3)

Part numbers are subject to change. Refer to Okilink II for current part numbers and pricing information.

Item	Okidata P/N Oki-J P/N	Description	Comments Refer to B.1.02	Disassembly Procedure
1	53563101 3PA4025-3720G1	Frame: Main (Narrow)	RSPL 590	3.2.30
1	53563201 3PA4025-3721G1	Frame: Main (Wide)	RSPL 591	3.2.30
2	50922901 4PP4025-3316P1	Spring: Front Pressure (Narrow)	RSPL 590	3.2.28
3	50922801 4PP4025-3324P1	Spring: Front Pressure (Wide)	RSPL 591	3.2.28
4	53341101 4PP4025-3317P1	Holder: Front Roller	RSPL Both	3.2.28
5	53341202 4PP4025-3327G1	Roller: Front Pressure	RSPL Both	3.2.28
6	51227801 3PP4025-3318P1	Shaft: Front Release Gear (Narrow)	RSPL 590	3.2.27
6	51227901 3PP4025-3505P1	Shaft: Front Release Gear (Wide)	RSPL 591	3.2.27
7	50097301 N/A	Pan: Paper (Narrow)	RSPL 590	3.2.27
7	50097401 1PP4025-3506P2	Pan: Paper (Wide)	RSPL 591	3.2.27
8	50923301 3PP4025-3346G1	Spring: Pressure (Narrow)	RSPL 590	3.2.24
8	50923401 3PP4025-3511G1	Spring: Pressure (Wide)	RSPL 591	3.2.24
9	50805201 4PP4025-3351P1	Lever: Switch (Cut Sheet/Continuous)	RSPL Both	3.2.24
10	51228301 4PP4025-3350P1	Arm: Front Release Gear	RSPL Both	3.2.24
11	50924701 4PP4025-3365P1	Spring: Lock	RSPL Both	3.2.20
12	50097701 3PA4025-3360G2	Paper Chute Assembly (Narrow)	RSPL 590	3.2.20
12	50097801 3PA4025-3515G2	Paper Chute Assembly (Wide)	RSPL 591	3.2.20
13	53341301 3PB4025-3364P1	Roller: Pressure Rear (Narrow)	RSPL 590	3.2.20
13	53341401 3PB4025-3517P1	Roller: Pressure Rear (Wide)	RSPL 591	3.2.20
14	50097501 3PA4025-3330G1	Tractor: Assembly (Narrow)	RSPL 590	3.2.29
14	50097502 3PA4025-3330G2	Tractor: Assembly (Wide)	RSPL 591	3.2.29

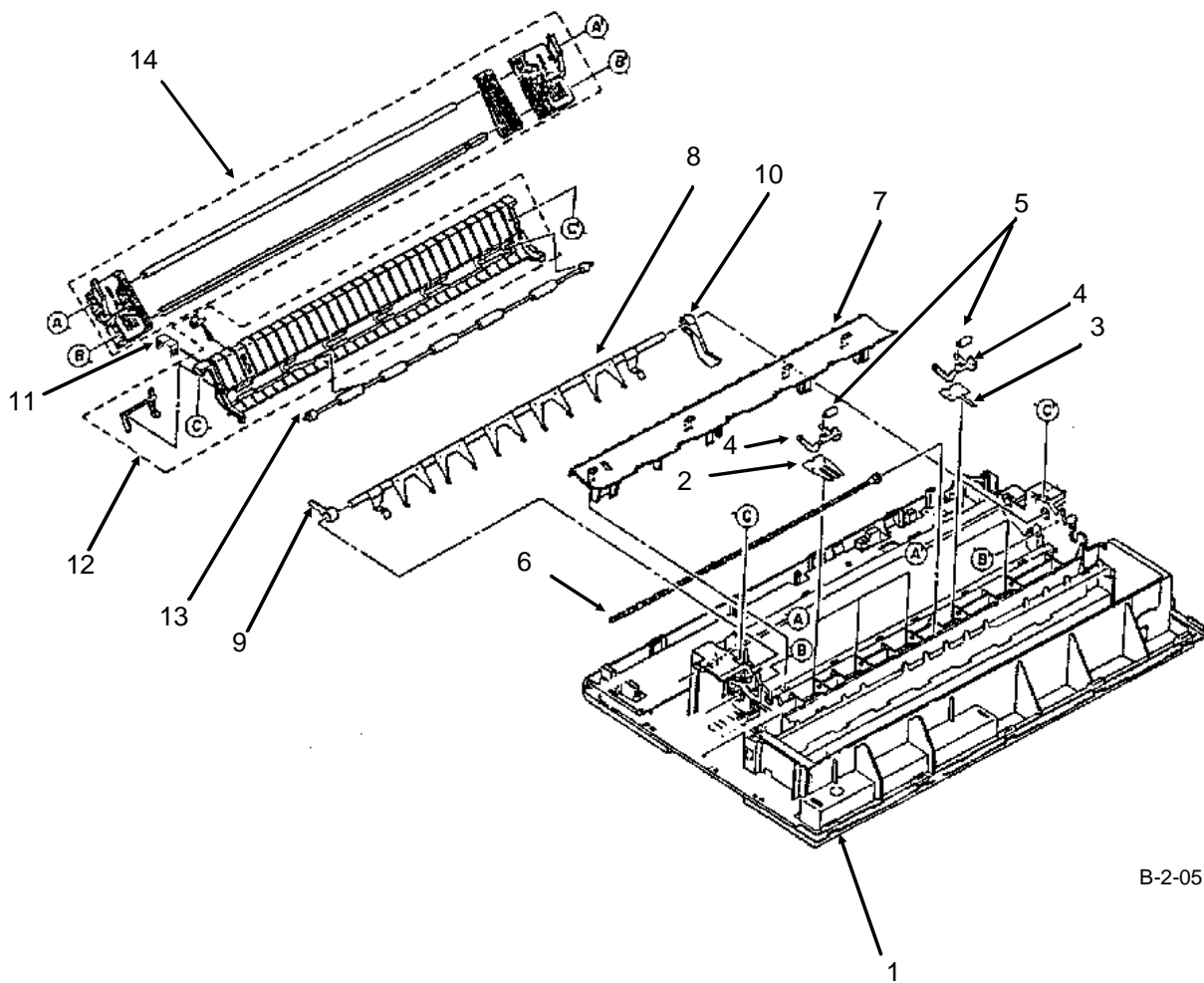

B-2-05.pcx

B.2.07 Carriage Assembly

Part numbers are subject to change. Refer to Okilink II for current part numbers and pricing information.

Item	Okidata P/N Oki-J P/N	Description	Comments Refer to B.1.02	Disassembly Procedure
1	50707401 3PP4025-3431P1	Clamp: Head	RSPL Both	3.2.03
2	53562801 3PP4025-3430P1	Protector: Ribbon	RSPL Both	3.2.03
3	51228501 3PA4025-3406G1	Gear: Case (Assembly)	RSPL Both	3.2.04
4	56729601 224A1285P0400	Connector: PC HD40	RSPL Both	3.2.10
5	53343001 4PP4025-3433P1	Holder: Connector (L)	RSPL Both	3.2.11
6	53343101 4PP4025-3434P1	Holder: Connector (R)	RSPL Both	3.2.11
7	56510401 4YA4025-3250G1	Motor: Space (Assembly)	RSPL Both	3.2.11
8	53343301 4PA4025-3719G1	Guide: Roller Assembly	Both	3.2.11
9	53341901 4PP4025-3398P1	Roller: Guide	RSPL Both	3.2.11
10	53342001 3PP4025-3399P1	Holder: Guide Roller	RSPL Both	3.2.11
11	N/A N/A	Pin	Both	3.2.11
12	N/A 4PP4025-3401P1	Guide Roller Spring	Both	3.2.11
13	56627301 2PU4007-1193P1	Cable: Carriage (Narrow)	RSPL 590	3.2.12
13	56627302 N/A	Cable: Carriage (Wide)	RSPL 591	3.2.12
14	53343201 4PA4025-3718G1	Assembly: Roller/Holder Backup	Both	3.2.14
15	53341701 4PP4025-3392P1	Roller: Back Up	RSPL Both	3.2.14
16	53341801 3PP4025-3393P1	Holder: Back Up Roller	RSPL Both	3.2.14
17	N/A N/A	Pin	Both	3.2.14
18	N/A 4PP4025-3397P1	Backup Roller Holder Spring	Both	3.2.14
19	50098901 4PP4025-3394G1	Carriage: Frame Set	RSPL Both	3.2.25

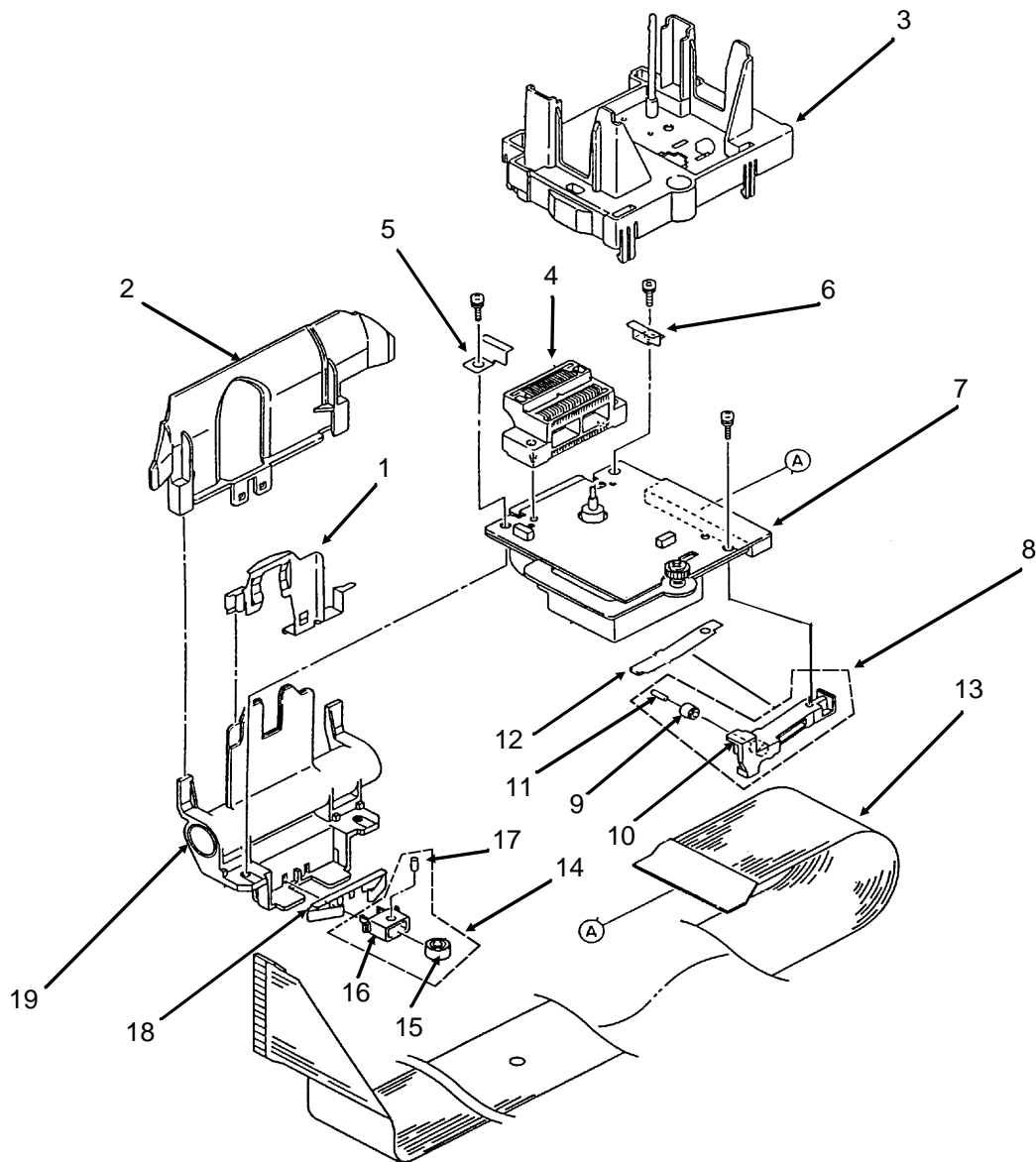

B-2-06.pcx

B.2.08 Options

Part numbers are subject to change. Refer to Okilink II for current part numbers and pricing information.

Item	Okidata P/N Oki-J P/N	Description	Comments Refer to B.1.02	Disassembly Procedure
1	70022501 N/A	Kit: Single Bin CSF Narrow	Option 590	N/A
1	70022701 N/A	Kit: Single Bin CSF Wide	Option 591	N/A
2	70023001 N/A	Kit: Pull Tractor Narrow	Option 590	N/A
2	70023201 N/A	Kit: Pull Tractor Wide	Option 591	N/A
3	70022901 N/A	Kit: Push Tractor (Bottom) Narrow	Option 590	N/A
3	70023101 N/A	Kit: Push Tractor (Bottom) Wide	Option 591	N/A
4	52106003 N/A	Color Kit (Incl color ribbon and ribbon shift bracket)	Option Both	N/A
5	52106002 N/A	Ribbon: Color	Consumable Both	N/A
6	51709101 3PA4025-3581G1	Bracket: Ribbon Shift (Color)	Option RSPL Both	N/A
7	70023301 N/A	Kit: Roll Paper Stand	Option 590	N/A
8	70016301 N/A	Buffer Expansion Card	Option Both	N/A
9	70000803 N/A	Kit: Parallel Interface Plug'n'Play Accessory	Option Both	N/A
10	70012801 N/A	Kit: RS232-C Serial Interface	Option Both	N/A
11	56412201 4YB4049-1708P1	Power Supply 230-240V	Option RSPL 590	3.2.08
11	56412202 4YB4049-1708P2	Power Supply 230-240V	Option RSPL 591	3.2.08
12	56624101 3YS4011-1265P1	Cord: AC (220V) (ML) Right Ang	Option RSPL Both	3.2.01
13	56624401 3YS4011-1268P1	Cord: AC 240V	Option RSPL Both	3.2.01

NOTE:

The Microline 590/591 printers are not shipped with an interface cable. The end user must purchase an interface cable separately from the printer.

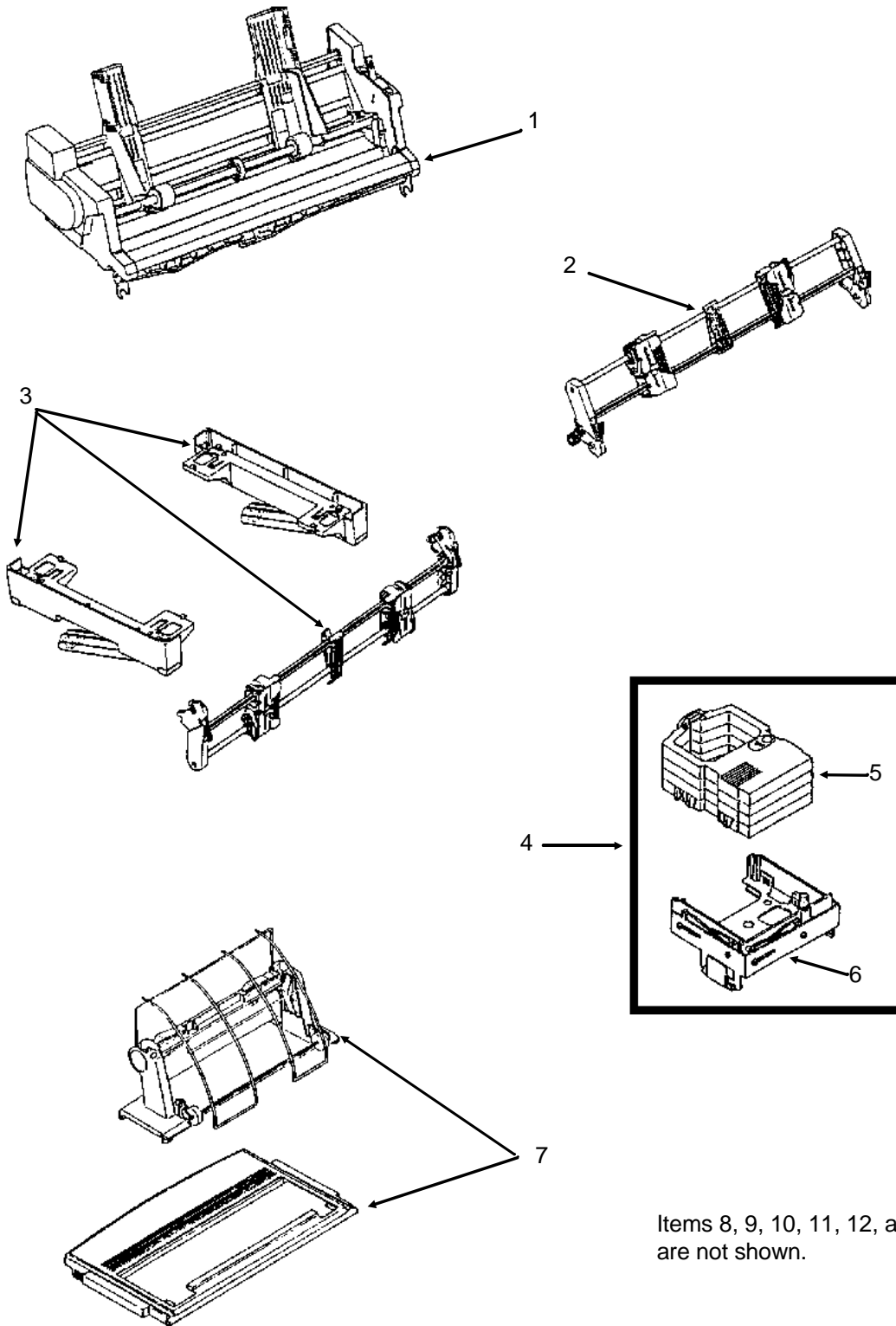

Items 8, 9, 10, 11, 12, and 13 are not shown.

B-2-07.pcx

B.2.09 Option Parts

Part numbers are subject to change. Refer to Okilink II for current part numbers and pricing information.

Item	Okidata P/N Oki-J P/N	Description	Comments Refer to B.1.02	Disassembly Procedure
1	50097901 N/A	Tractor: Pull and Bottom Assembly (Right)	Option RSPL Both	N/A
2	50098001 4PA4025-3608G1	Tractor: Pull and Bottom Assembly (Left)	Option RSPL Both	N/A
3	50098501 2PA4094-6510G3	Stand: Bottom Push (Right)	Option RSPL Both	N/A
4	50098502 2PA4094-6510G4	Stand: Bottom Push (Left)	Option RSPL Both	N/A
5	50098701 4PP4094-7385G1	Knife: Paper (N) Bottom Push Tractor	Option RSPL 590	N/A
5	50098801 4PP4094-7386G1	Knife: Paper (W) Bottom Push Tractor	Option RSPL 591	N/A
6	50098101 2PP4094-7383G1	Tractor: Cover Assembly (N) Pull Tractor	Option RSPL 590	N/A
6	50098201 2PP4094-7384G1	Tractor: Cover Assembly (W) Pull Tractor	Option RSPL 591	N/A
7	53067401 1PP4053-2574P1	Cover: Side (Left) Cut-Sheet Feeder	Option RSPL Both	N/A
8	53067501 1PP4053-2575P1	Cover: Side (Right) Cut-Sheet Feeder	Option RSPL Both	N/A
9	53563001 4PP4053-2547G1	Shoe: Brake Cut-Sheet Feeder	Option RSPL Both	N/A
10	55937301 4YA4050-3026G1	PCB: NCSF Cut-Sheet Feeder	Option RSPL Both	N/A
11	56627501 3YS4011-5120G1	Cable: CSF Cut-Sheet Feeder	Option RSPL Both	N/A
12	51010001 1PP4053-2570P2	Guide: Front Sheet (N) Cut-Sheet Feeder	Option RSPL 590	N/A
12	51010101 1PP4053-2571P2	Guide: Front Sheet (W) Cut-Sheet Feeder	Option RSPL 591	N/A
13	56510501 3PB4053-2560P1	Motor Pulse Cut-Sheet Feeder	Option RSPL Both	N/A
14	53562901 1PP4053-2576P1	Supporter: Front Sheet (N) Cut-Sheet Feeder	Option RSPL 590	N/A
14	53480901 1PP4043-1891P4	Supporter: Front Sheet (W) Cut-Sheet Feeder	Option RSPL 591	N/A
15	50062801 4PB4053-1705G1	Roller: Hopping (L.H.) Cut-Sheet Feeder	Option RSPL Both	N/A
16	50062802 4PB4053-1705G2	Roller: Hopping (R.H.) Cut-Sheet Feeder	Option RSPL Both	N/A
17	53321501 3PB4025-1941P1	Support: Rear Sheet Cut-Sheet Feeder	Option RSPL Both	N/A
18	53448501 4PB4025-1914P1	Sheet: Friction Cut-Sheet Feeder	Option RSPL Both	N/A
19	56306001 4YB4021-1146P1	Fuse: 3.15 A for 230/240V Power Supply	Option RSPL Both	3.2.08
20	55038901 4YA4021-1050G1	PCB: LXHI (RS232-C)	Option RSPL Both	N/A

No pictures were available at press time.

B.2.10 Consumables

Part numbers are subject to change. Refer to Okilink II for current part numbers and pricing information.

Item	Okidata P/N Oki-J P/N	Description	Comments Refer to B.1.02	Disassembly Procedure
1	52106001 N/A	Ribbon: Black	Consumable Both	3.2.02
2	52106002 N/A	Ribbon: Color	Consumable Both	3.2.02

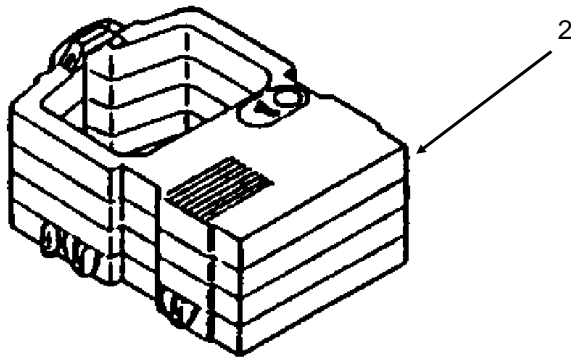
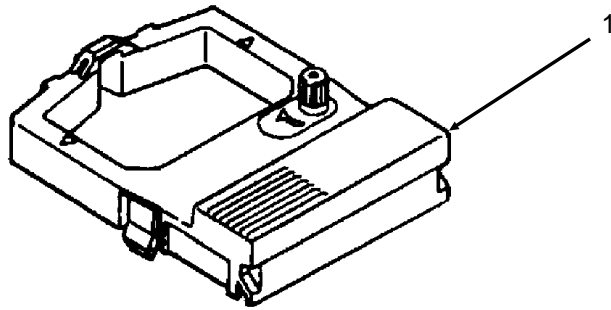

B-2-09.pcx

B.2.11 Packing Materials

Part numbers are subject to change. Refer to Okilink II for current part numbers and pricing information.

Item	Okidata P/N Oki-J P/N	Description	Comments Refer to B.1.02	Disassembly Procedure
1	53564901 N/A	Box: Graphic	RSPL 590	N/A
1	53565001 N/A	Box: Graphic	RSPL 591	N/A
2	53565401 N/A	Foam: Molded (Left)	RSPL Both	N/A
3	53565402 N/A	Foam: Molded (Right)	RSPL Both	N/A

No pictures were available at press time.

B.2.12 Documentation

Part numbers are subject to change. Refer to Okilink II for current part numbers and pricing information.

Item	Okidata P/N Oki-J P/N	Description	Comments Refer to B.1.02	Disassembly Procedure
1#	58229001 N/A	Kit: ML590/591 Service Training	Document Both	N/A
1#	58229002 N/A	Kit: ML590/591 Service Training	Document Both	N/A
1#	58229003 N/A	Kit: ML590/591 Service Training	Document Both	N/A
2	58233302 N/A	Package: User's Documentation	Document Inc. 3 4 5 6 7	N/A
3	52033001 N/A	Card: QA Reply	Document Part of 2	N/A
4	53436029 N/A	Bag: Poly 9" x 12"	Document Part of 2	N/A
5	52050806 N/A	Card: Reply (OkiSmart)	Document Part of 2	N/A
6	58078001 N/A	Card: Registration	Document Part of 2	N/A
7	59254703 N/A	Handbook: Printer	Document Part of 2	N/A
8	59254201 N/A	Manual: Maintenance	Document Both	N/A
9	59254301 N/A	Manual: Troubleshooting	Document Both	N/A
10	59253901 N/A	Product Specifications	Document Both	N/A

* To order Marketing Literature, complete an Okidata Marketing Literature Order Form. Fax the completed form to Okidata Marketing Communications.

** Obtain this form by faxing a request to Okidata Marketing Communications. Refer to the Service Center Reference Guide for information on contacting Okidata.

See the following pages

Item	Okidata P/N Oki-J P/N	Description	Comments Refer to B.1.02	Disassembly Procedure
11	N/A N/A	Okidata Service Center Reference Guide	Document	N/A
12	53547501 N/A	Okidata Support 3-Ring Binder	Document	N/A
13	58067201 N/A	ABCD Warranty Claim Forms (Pkg of 20)	Document	N/A
14	58052401 N/A	Warranty Summary Forms (Pkg of 20)	Document	N/A
15	N/A N/A	Printer Drivers	Refer to Okilink	N/A
16	N/A N/A	Product Updates	Document Refer to Okilink	N/A
17	N/A N/A	Recommended Spare Parts List	Document Refer to Okilink	N/A
18	N/A N/A	Software	Refer to Okilink	N/A
19	N/A N/A	Technical Service Bulletins	Document Refer to Okilink	N/A
20 *	N/A N/A	Marketing Literature	Document	N/A
21 **	N/A N/A	Okidata Marketing Literature Order Form	Document	N/A

* To order Marketing Literature, complete an Okidata Marketing Literature Order Form. Fax the completed form to Okidata Marketing Communications.

** Obtain this form by faxing a request to Okidata Marketing Communications. Refer to the Service Center Reference Guide for information on contacting Okidata.

See the following pages

B.2.13 Service Training Kit Revision List

P/N 58229001 Microline 590/591 Service Training Kit

This kit was replaced by P/N 58229001.

Items in the training kit (except for the Printer Handbook) are NOT available separately.

Item	Okidata P/N Oki-J P/N	Description	Comments Refer to B.1.02	Disassembly Procedure
1 A	58229001 N/A	Kit: ML590/591 Service Training	Document Both	N/A
2 A	52062701 N/A	Label: Box	Document	N/A
3 A	58229101 N/A	Administration Package	Document	N/A
4 A	58088001 N/A	Envelope: Administration Package	Document	N/A
5 A	58088101 N/A	Cover Letter	Document	N/A
6 A	59256201 N/A	Training Guide	Document	N/A
7 A	58088201 N/A	Printhead Gap Adjustment Material	Document	N/A
8 A	58088301 N/A	Certification Test	Document	N/A
9 A	58088401 N/A	Certification Test Answer Sheet	Document	N/A
10 A	58088501 N/A	Course Critique	Document	N/A
11 A	58088601 N/A	Envelope: Pre-Printed Return	Document	N/A
12 A	59256301 N/A	Service Handbook	Document	N/A
13 A	59256401 N/A	User's Documentation	Document	N/A
14 A	52033001 N/A	Card: QA Reply	Document Both	N/A
15 A	52050806 N/A	Card: Reply (OkiSmart)	Document Both	N/A
16 A	58078001 N/A	Card: Registration	Document Both	N/A
17 A	59254703 N/A	Handbook: Printer	Document Both	N/A
18 A	57519501 N/A	Service Videotape	Document	N/A
19 A	52062702 N/A	Label: Service Videotape Case	Document	N/A
20 A	52062703 N/A	Label: Service Videotape Front	Document	N/A
21 A	52062704 N/A	Label: Service Videotape Spine	Document	N/A
22 A	57517101 N/A	Red Vinyl Case (VHS Videotape)	Document	N/A
23 A	53567001 N/A	Storage Box	Document	N/A
24 A	53567101 N/A	Cardboard Sleeve	Document	N/A

P/N 58229002 Microline 590/591 Service Training Kit

This kit was replaced by P/N 58229003.

Items in the training kit (except for the Printer Handbook) are NOT available separately.

Item	Okidata P/N Oki-J P/N	Description	Comments Refer to B.1.02	Disassembly Procedure
1 B	58229002 N/A	Kit: ML590/591 Service Training	Document Both	N/A
2 B	52062702 N/A	Label: Kit	Document	N/A
3 B	58088102 N/A	Read Me First	Document	N/A
4 B	59256302 N/A	Service Handbook	Document	N/A
5 B	59254703 N/A	Printer Handbook	Document	N/A
6 B	57519501 N/A	Service Videotape	Document	N/A
7 B	52062704 N/A	Label: Service Videotape Spine	Document	N/A
8 B	53570401 N/A	Sleeve: Videotape (Cardboard)	Document	N/A

P/N 58229003 Microline 590/591 Service Training Kit

This kit replaces P/N 58229002.

Items in the training kit (except for the Printer Handbook) are NOT available separately.

Item	Okidata P/N Oki-J P/N	Description	Comments Refer to B.1.02	Disassembly Procedure
1 C	58229003 N/A	Kit: ML590/591 Service Training	Document Both	N/A
2 C	52062706 N/A	Label: Kit	Document	N/A
3 C	58088103 N/A	Read Me First	Document	N/A
4 C	59256303 N/A	Service Handbook	Document	N/A
5 C	59254703 N/A	Printer Handbook	Document	N/A
6 C	57519502 N/A	Service Videotape	Document	N/A
7 C	52062704 N/A	Label: Service Videotape Spine	Document	N/A
8 C	53570401 N/A	Sleeve: Videotape (Cardboard)	Document	N/A

This page was intentionally left blank.



Microline 590/591 Service Handbook

P/N 59256303