

Spicer® Single Drive Axles

**SPICER**®

---



# Service Manual

---

**Spicer® Drive Axles**

**AXSM-8941**

**September 2007**

## General Information

The description and specifications contained in this service publication are current at the time of printing. Dana Corporation reserves the right to discontinue or to modify its models and/or procedures and to change specifications at any time without notice.

Any reference to brand names in this publication is made simply as an example of the types of tools and materials recommended for use and should not be considered an endorsement. Equivalents, if available, may be used.

### Important Notice

This symbol is used throughout this manual to call attention to procedures where carelessness or failure to follow specific instructions may result in personal injury and/or component damage.

Departure from the instructions, choice of tools, materials and recommended parts mentioned in this publication may jeopardize the personal safety of the service technician or vehicle operator.



**WARNING:** Failure to follow indicated procedures creates a high risk of personal injury to the servicing technician.

**CAUTION:** Failure to follow indicated procedures may cause component damage or malfunction.

**IMPORTANT:** Highly recommended procedures for proper service of this unit.

---

**NOTE:** Additional service information not covered in the service procedures.

**TIP:** Helpful removal and installation procedures to aid in the service of this unit.

*Always use genuine Dana replacement parts.*

Table of Contents - Visual

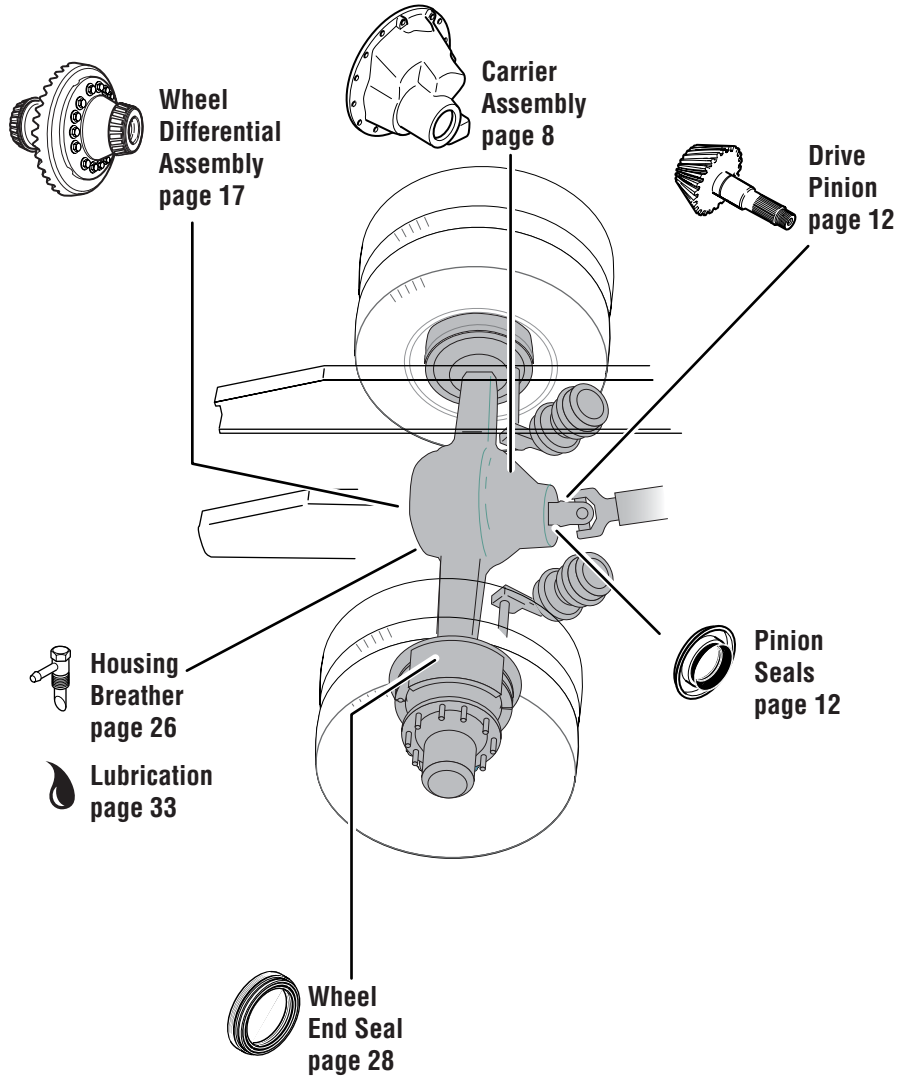

## Table of Contents

### General Information

Introduction	1
Model Identification	2
Parts Identification	3
Ring Gear and Pinion	4

### Inspection

Failure Analysis	5
Prepare the Parts for Inspection	6
Inspection	7
Clean	7
Inspect Axle Housing	7
Inspect Primary Gearing	7

### Differential Carrier Assembly

Differential Carrier Assembly - Exploded View	8
Removal of Differential Carrier From Axle Housing	9
Install Differential Carrier	10
Remove Wheel Differential	11

### Pinion Assembly

Rear Axle Pinion Assembly - Exploded View	12
Remove Pinion Assembly	13
Install Pinion Assembly	15

### Wheel Differential Assembly

Wheel Differential Assembly - Exploded View	17
Disassemble, Overhaul and Assemble Wheel Differential	18
Disassemble Wheel Differential	18
Overhaul and Assemble Wheel Differential	20

### Wheel Differential Adjustments

Measure and Adjust Carrier Assembly (Adjust Backlash and Preload)	22
Change Backlash Setting	23

### Adjust Tooth Contact Pattern

Adjust Ring and Pinion Tooth Contact Pattern	24
Adjust Ring Gear Position (Backlash)	25

### Housing Breather

Install New Axle Housing Breather - (Metal and Plastic)	26
---	----

### Axle Housing

Axle Housing - Exploded View	27
------------------------------	----

### Wheel End Seal

Wheel End Seal Parts - Exploded View	28
Remove and Overhaul Wheel End Seal	29
Install Wheel End Seal	29

### Wheel Adjustment Systems

Adjust Wheel Bearing	30
----------------------	----

### Wheel Ends

Verify Wheel End-Play Procedure	32
---------------------------------	----

### Lubrication

Lubricate Wheel End	33
General Lubrication Information	35
Approved Lubricants	35
Recommendations for Viscosity/ Ambient Temperature	35
Lube Change Intervals	36
Change Lube	37
Drain	37
Fill	37

### Proper Vehicle Towing

With Truetrac Limited Slip Differential	38
Torque Flow	39

### Parts Identification

Rear Drive Axle Parts - Exploded View	40
---------------------------------------	----

### Torque Specifications

Fastener Torque Specifications	41
--------------------------------	----

### Service Tools

Recommended Service Tools	42
---------------------------	----

## Introduction

Dana Corporation presents this publication to aid in maintenance and overhaul of Dana single reduction drive axles. Instructions contained cover the models listed below. Their design is common, with differences in load capacity. Capacity variations are achieved by combining basic differential carrier assemblies with different axle housings, axle shafts, and wheel equipment.

### Model Listing

The following models are included in this publication:

Dana Single Reduction Axles With Standard Wheel Differential		
S135L	S135N	S135S
S150L	S150N	S150S

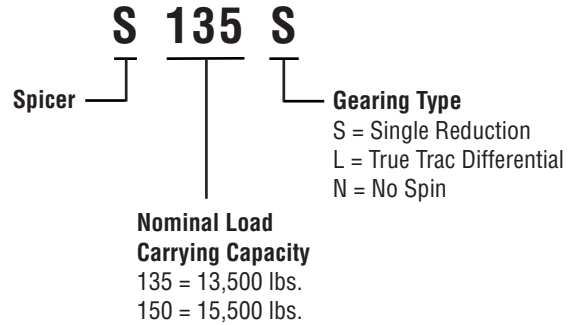

Model Identification

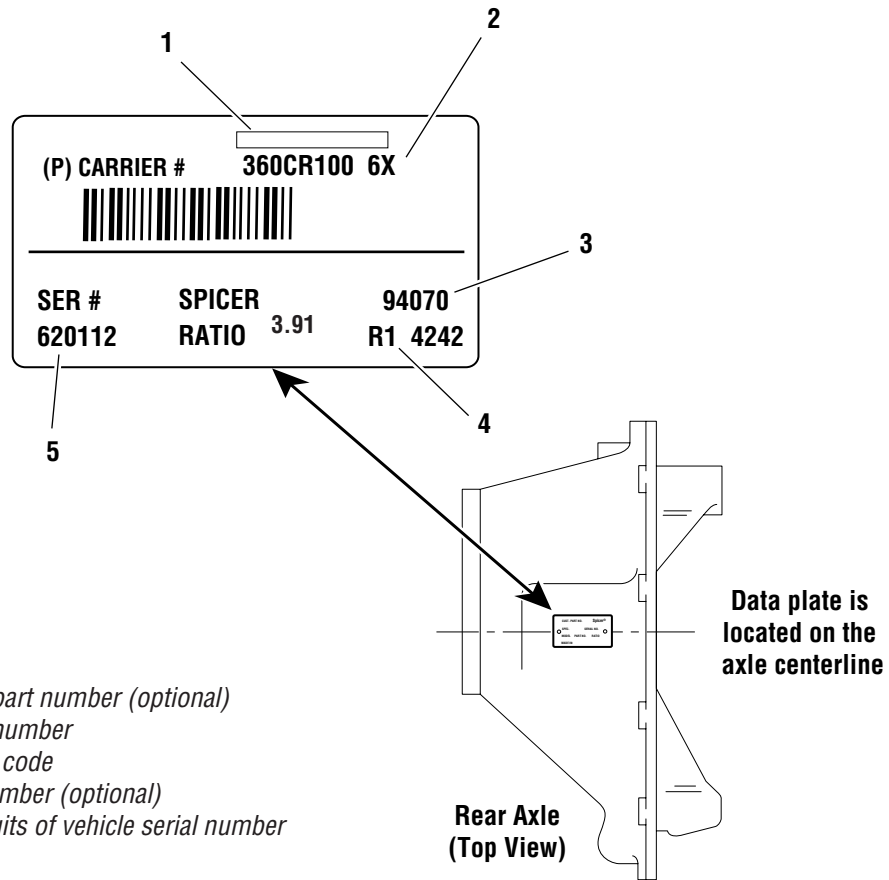

- 1 - Customer part number (optional)
- 2 - Dana part number
- 3 - Julian date code
- 4 - Line set number (optional)
- 5 - Last six digits of vehicle serial number (optional)

## Parts Identification

### Axle Housing

### Julian Date Code

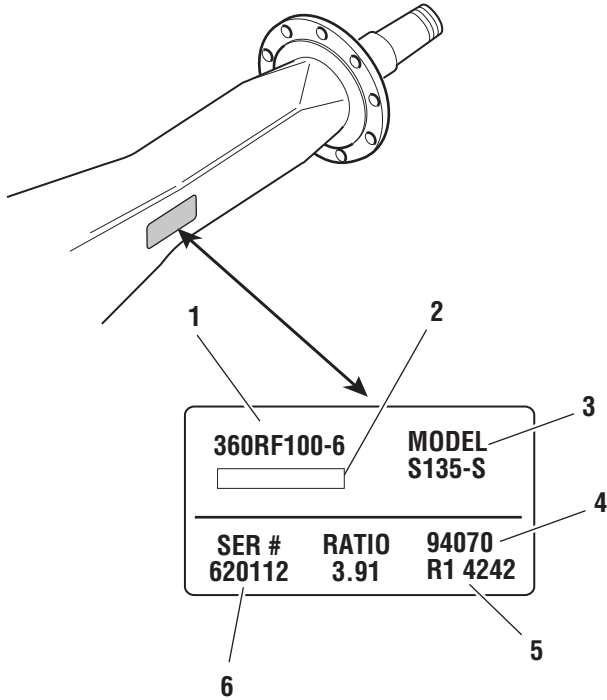
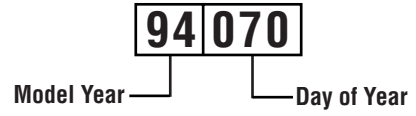

- 1 - Dana part number
- 2 - Customer part number (optional)
- 3 - Model
- 4 - Julian date code
- 5 - Line set number (optional)
- 6 - Last six digits of vehicle serial number (optional)

### Axle Shaft

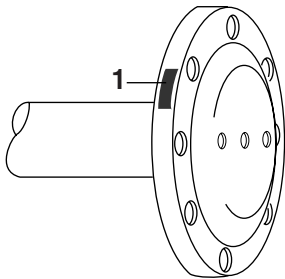

- 1 - Axle shaft part number

## Ring Gear and Pinion

Manufacturer's Date - Date gear set was made.

**Spicer Trademark** - Company logo and location of manufacturing facility.

**360GP104** - Part number of pinion gear. (TYPICAL)

**Tooth Combination (i.e. 41-11)** - Indicates the pinion has 11 teeth and the ring gear has 41 teeth which results in a 3.73:1 ratio.

**Matched Set Number** - Spicer ring and pinions are manufactured as matched sets. Both ring and pinion are marked with a corresponding number (i.e. 260), which identifies them as a matched set.

A gear set that does not have the same match set numbers should not be mated together. If either ring gear or pinion require replacement, a new matched set must be used.

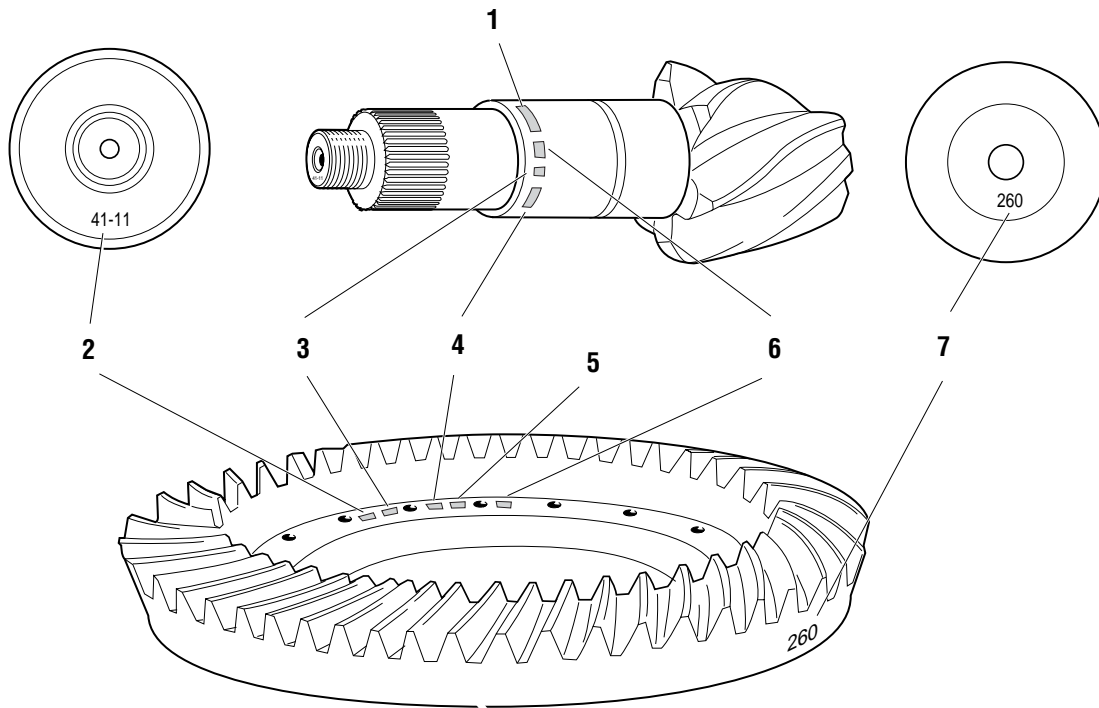

- 1 - Spicer trademark
- 2 - Tooth combination
- 3 - Part number
- 4 - Heat code

- 5 - Spicer trademark
- 6 - Manufacturer's date
- 7 - Matched set number



## Failure Analysis

Failure analysis is the process of determining the original cause of a component failure in order to keep it from happening again. Too often, when a failed component is replaced without determining its cause, there will be a recurring failure. If a carrier housing is opened, revealing a ring gear with a broken tooth, it is not enough to settle on the broken tooth as the cause of the carrier failure. Other parts of the carrier must be examined. For a thorough understanding of the failure and possible insight into related problems, the technician needs to observe the overall condition of the vehicle.

No one benefits when a failed component goes on the junk pile with the cause unknown. Nothing is more disturbing to a customer than a repeat failure. Systematically analyzing a failure to prevent a repeat occurrence assures quality service by avoiding unnecessary downtime and further expense to the customer.

The true cause of a failure can be better determined by knowing what to look for, determining how a piece of the equipment was running and learning about previous problems. In the case of a rebuilt rear axle, mismatched gears may have been installed.

The more successful shops prevent repeat equipment failures by developing good failure analysis practices. Knowing how to diagnose the cause of a premature failure is one of the prerequisites of a good heavy-equipment technician.

### How to Diagnose a Failure

The following five steps are an effective approach to good failure diagnostics:

1. Document the problem.
2. Make a preliminary investigation.
3. Prepare the parts for inspection.
4. Find the cause of the failure
5. Correct the cause of the problem.

### Document the Problem

Here are some guidelines for starting to learn about a failure, including questions to ask:

- Talk to the operator of the truck.
- Look at the service records.
- Find out when the truck was last serviced.
- Ask: In what type of service is the truck being used?
- Ask: Has this particular failure occurred before?
- Ask: How was the truck working prior to the failure?

You need to be a good listener. Sometimes, insignificant or unrelated symptoms can point to the cause of the failure.

- Ask: Was the vehicle operating at normal temperatures?
- Ask: Were the gauges showing normal ranges of operation?
- Ask: Was there any unusual noise or vibration?

After listening, review the previous repair and maintenance records. If there is more than one driver, talk to all of them and compare their observations for consistency with the service and maintenance records. Verify the chassis Vehicle Identification Number (VIN) number from the vehicle identification plate, as well as the mileage and hours on the vehicle.

### Make a Preliminary Investigation

These steps consist of external inspections and observations that will be valuable when combined with the results of the parts examination.

- Look for leaks, cracks, or other damage that can point to the cause of the failure.
- Make note of obvious leaks around plugs and seals. A missing fill or drain plug would be an obvious cause for concern.
- Look for cracks in the carrier housing (harder to see, but sometimes visible).
- Does the general mechanical condition of the vehicle indicate proper maintenance or are there signs of neglect?
- Are the tires in good condition and do the sizes match?
- If equipped with a torque-limiting device, is it working properly?

During the preliminary investigation, write down anything out of the ordinary for later reference. Items that appear insignificant now may take on more importance when the subassemblies are torn down.

---

## Prepare the Parts for Inspection

After the preliminary investigation, locate the failure and prepare the part for examination. In carrier failure analysis, it may be necessary to disassemble the unit.

- When disassembling subassemblies and parts, do not clean the parts immediately since cleaning may destroy some of the evidence.
- When tearing down the drive axle, do it in the recommended manner. Minimize any further damage to the unit.
- Ask more questions when examining the interior of the carrier. Does the lubricant meet the manufacturer specifications regarding quality, quantity, and viscosity? As soon as you have located the failed part, take time to analyze the data.

### Find the Cause of the Failure

Here begins the real challenge to determine the exact cause of the failure. Keep in mind that there is no benefit to replacing a failed part without determining the cause of the failure. For example, after examining a failed part and finding that the failure is caused by a lack of lubrication, you must determine if there was an external leak. Obviously, if there is an external leak, just replacing the failed gear is not going to correct the situation.

Another important consideration here is to determine the specific type of failure which can be a valuable indicator for the cause of failure. The following pages show different types of failures and possible causes. Use this as a guide in determining types of failures and in correcting problems.

### Correct the Cause of the Problem

Once the cause of the problem has been determined, refer to the appropriate service manual to perform the repairs.

## Inspection

### Clean

1. Wash steel parts with ground or polished surfaces in solvent. There are many suitable commercial solvents available. Kerosene and diesel fuel are acceptable.

**WARNING:** Gasoline is not an acceptable solvent because of its extreme combustibility. It is unsafe in the workshop environment.

2. Wash castings or other rough parts in solvent or clean in hot solution tanks using mild alkali solutions.

**Note:** If a hot solution tank is used, make sure parts are heated thoroughly before rinsing.

3. Rinse thoroughly to remove all traces of the cleaning solution.
4. Dry parts immediately with clean rags.
5. Oil parts.
  - If parts are to be reused immediately: Lightly oil.
  - If parts are to be stored: Coat with oil, wrap in corrosion resistant paper and store in a clean, dry place.

### Inspect Axle Housing

Axle housing inspection and repairs are limited to the following checks or repairs:

- Visually inspect axle housing for cracks, nicks and burrs on machined surfaces.
- Check carrier bolt holes and studs for foreign material.
- Replace damaged fasteners. Look for loose studs or cross threaded holes.

**CAUTION:** Any damage which affects the alignment or structural integrity of the housing requires housing replacement. Do not repair by bending or straightening. This process can affect the material's properties and cause it to fail completely under load.

- Check all seals and gaskets.

**Note:** Replace conventional gaskets with silicone rubber gasket compound (included in many repair kits). The compound provides a more effective seal against lube seepage and is easier to remove from mating surfaces when replacing parts.

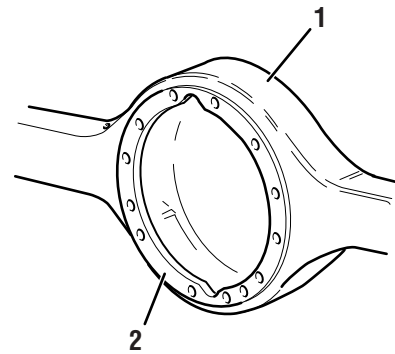

1 - Axle Housing  
2 - Machined Surface

#### Inspect all steel parts for:

- Notches, visible steps or grooves created by wear.
- Pitting or cracking along gear contact lines.
- Scuffing, deformation, or discolorations. These are signs of excessive heat in the axle and are usually related to low lubrication levels or improper lubrication practices.

#### In addition, inspect the following for damage:

- Differential gearing.
- Bearings for loose fit on drive pinion, pilot bearing, and differential bearings.
- All fasteners for rounded heads, bends, cracks or damaged threads.
- Inspect machined surfaces of cast or malleable parts. They must be free of nicks, burrs, cracks, scoring, and wear.
- Look for elongation of drilled holes, wear on surfaces machined for bearing fits and nicks or burrs in mating surfaces.

### Inspect Primary Gearing

Before reusing a primary gear set, inspect teeth for signs of excessive wear. Check tooth contact pattern for evidence of incorrect adjustment.

## Differential Carrier Assembly - Exploded View

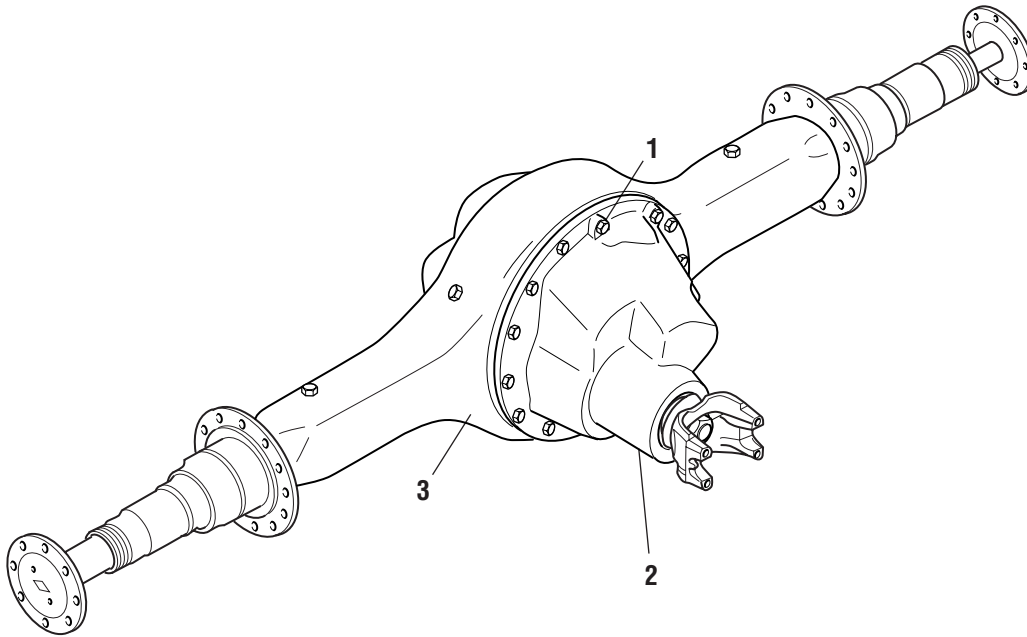

- 1 - Carrier fasteners
- 2 - Carrier assembly
- 3 - Single axle assembly

## Removal of Differential Carrier From Axle Housing

1. Block wheels.
2. Remove axle housing drain plug and drain lubricant.
3. Disconnect drive shafts at the rear U-joint.

**Note:** If end yoke and/or seal is to be replaced, loosen yoke nut at this time.

4. Remove axle shaft flange nuts.
5. Hold a large brass drift or a brass hammer against the center of the axle shaft flange. Strike the drift with a large hammer or sledge until the axle shaft separates from the hub.

**CAUTION:** Do not strike the flange directly with a steel hammer or sledge. This may crack and splinter material, possibly causing serious or fatal injury. Do not pry or chisel axle flange away from hub; damage to sealing surfaces could occur.

6. Remove axle shafts.
7. Support the differential carrier assembly on a roller jack. Secure as necessary to prevent it from falling off the jack when removed from the housing.

8. Loosen all but the top two carrier-to-housing mounting bolts. Remove all bolts except the top two. These two bolts will prevent the carrier assembly from falling.
9. Separate the differential carrier from the housing using the removal slots. Make sure the carrier is balanced properly on jack. Remove the top two carrier mounting bolts. Remove the differential carrier assembly from the axle housing.

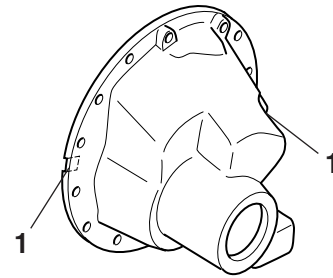

1 - Removal slots

10. Mount carrier assembly in a suitable rebuild stand.

## Install Differential Carrier

**IMPORTANT:** Before installing the carrier assembly, inspect and thoroughly clean interior of axle housing using an appropriate solvent and clean rag.

1. Apply Dana approved RTV compound on axle housing mating surface as shown in the illustration. Completely remove all old gasket material prior to applying new material. Compound will set in 20 minutes. Install carrier before compound sets or reapply.

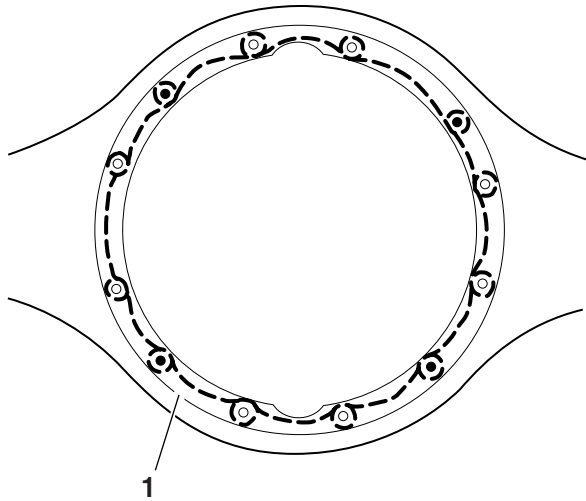

1 - Apply silicone gasket in this pattern

**TIP:** To assist in installing complete differential carrier use two pieces of threaded rod threaded into carrier cap screw holes. Rod should be approximately 6" long. Use these to pilot the carrier into the housing.

2. Install carrier to housing, washers, cap screws, and nuts. Torque to proper specifications. See torque chart of page 41.
3. Install axle shafts and axle stud nuts (if used, also install lock washers and tapered dowels).
4. Add axle lubricant. Fill to the bottom of the fill hole.
5. Connect inter-axle driveline, making sure all yokes are in phase. Lubricate U-joints.

## Remove Wheel Differential - All Standard Models

1. Mount differential carrier in repair stand.

**Note:** Omit this step if the gear set is to be replaced. If gear set is to be reused, check tooth contact pattern and ring gear backlash before disassembling differential carrier. When checking backlash, a yoke or helical gear must be installed and torqued to get an accurate reading. Best results are obtained when established wear patterns are maintained in used gearing.

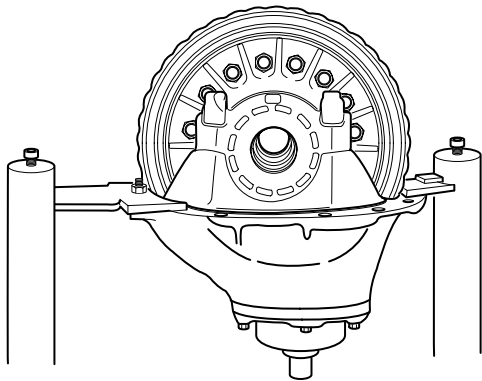

2. If reusing gear set, also punch mark bearing adjusters for reference during assembly.

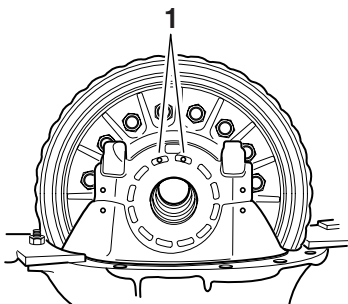

3. Remove cap screws, flat washers, and bearing caps. Loosen bearing adjusters and remove adjusters and bearing cups.

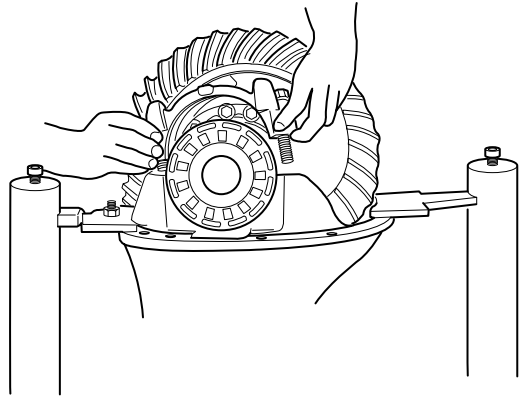

4. Using a chain hoist, lift ring gear and differential assembly out of carrier.

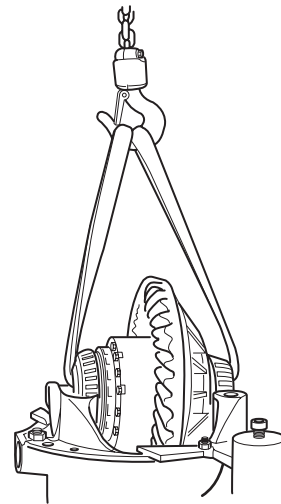

## Rear Axle Pinion Assembly - Exploded View

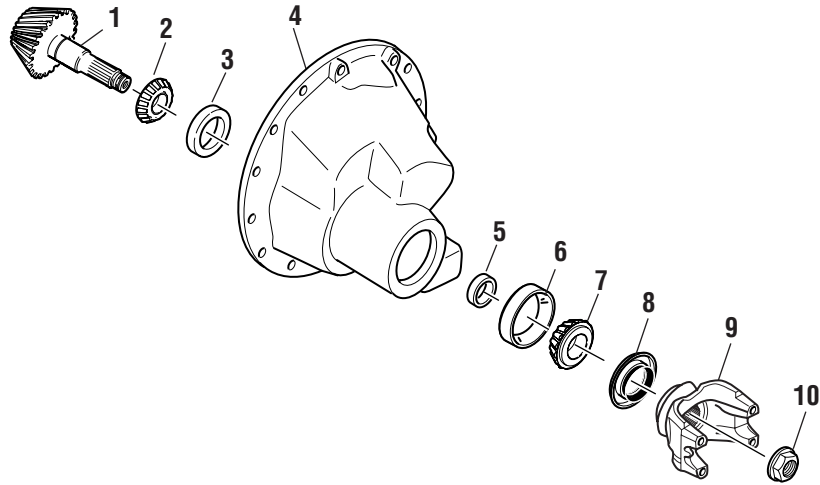

- 1 - Pinion
- 2 - Inner pinion bearing cone
- 3 - Inner pinion bearing cup
- 4 - Carrier housing
- 5 - Pinion preload spacer (Selective)

- 6 - Outer pinion bearing cup
- 7 - Outer pinion bearing cone
- 8 - Pinion seal
- 9 - End yoke assembly
- 10 - Pinion hex nut



## Remove Pinion Assembly

1. Remove yoke nut.

**Note:** Use of a torque multiplier is recommended as torque specification on input nut is 700-900 lbs. ft. (950-1,220 N•m).

2. Remove yoke using a yoke puller service tool.

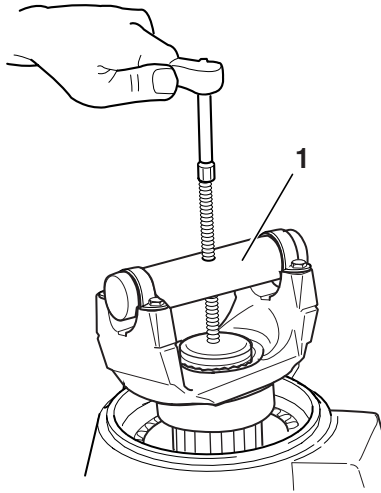

1 - Yoke puller

3. Remove oil seal.

4. Place carrier in a press with threaded end of pinion face up.

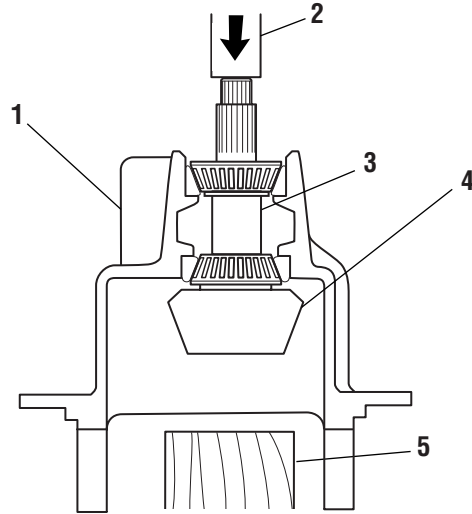

1 - Carrier assembly  
 2 - Press  
 3 - Bearing preload spacer  
 4 - Pinion  
 5 - Wood block

5. Place a wood block under pinion to avoid damage to gear teeth.
6. Press pinion through outer bearing and out of carrier casting.
7. Remove bearing preload spacer and save for use in reassembly.
8. If the gearset is to be reused, remove inner bearing at this time with a suitable puller. If the gearset is to be replaced, new bearings must be installed.

9. If bearings are to be replaced, remove bearing cups from carrier casting at this time.
  - a. Mount puller vertically to separate the bearing. This action will force puller halves under bearing and start moving bearing off pinion.

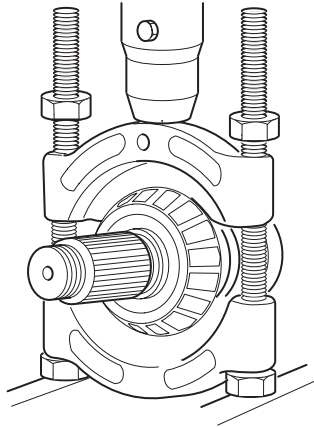

- b. Mount puller horizontally to press pinion out of bearing.

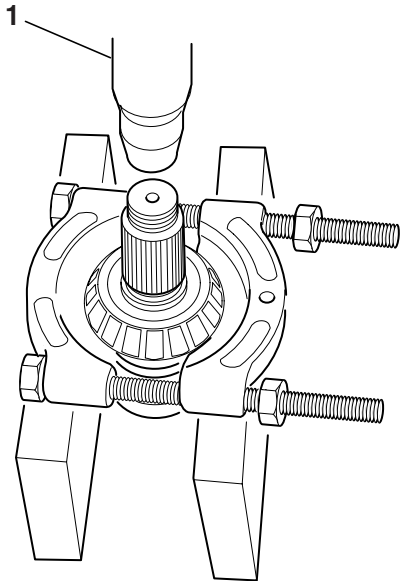

1 - Press

## Install Pinion Assembly

1. Press inner bearing cone onto pinion.

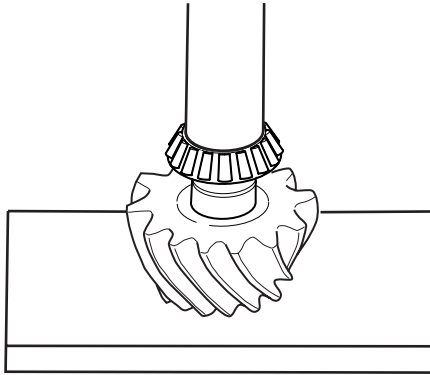

2. Press inner and outer bearing cups into the carrier until seated. Use a feeler gage (approximately 0.0015") to make sure bearing cups are fully seated in bearing bores. Apply lubricant to both cup and cone.
3. Place carrier housing in press with the pinion supported by wood block (6" X 6" X 6"), so the inner pinion bearing is mated to the cone.

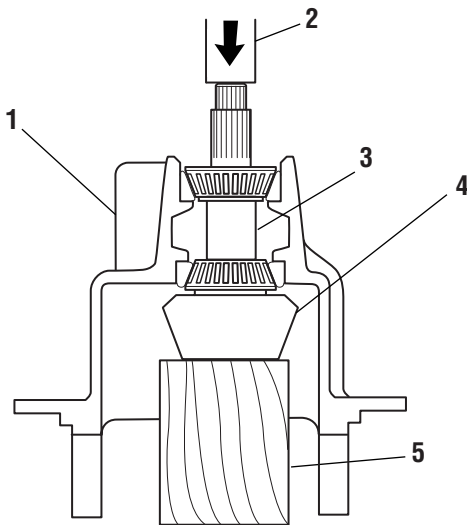

- 1 - Carrier assembly
- 2 - Press
- 3 - Bearing preload spacer
- 4 - Pinion
- 5 - Wood block

4. Insert original preload spacer and outer bearing onto pinion.
5. Press outer bearing onto pinion until completely seated.

6. Inspect end yoke or flange for grooves in seal surface caused by contaminants. If grooves can be detected with fingernail, then end yoke must be repaired with a CR approved repair sleeve or replaced.
7. Use yoke installer service tool and install yoke without seal.

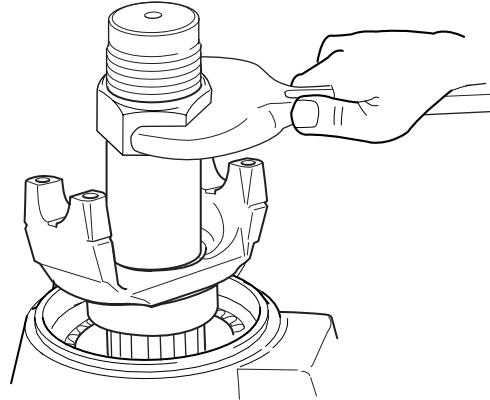

8. Use torque multiplier and torque pinion nut to 700-900 lbs. ft. (950-1,220 N•m).
9. Measure torque to rotate with an inch-pound torque wrench. Torque measurements should be taken every fourth revolution and should read between 10-40 lbs. in. of bearing preload.

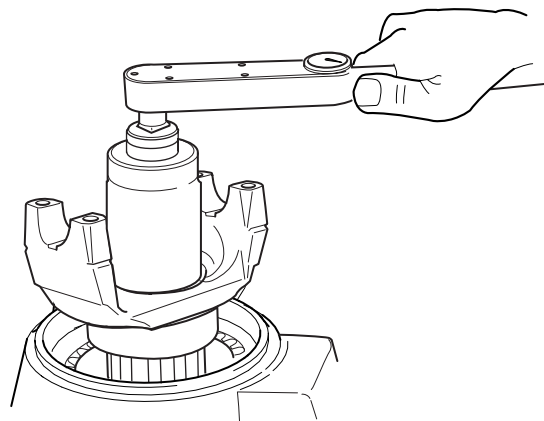

**Note:** If bearing preload does not fall within allowed limits, preload can be increased by using a thinner spacer and decreased by using a thicker spacer.

0.001" change in preload spacer thickness will change torque to rotate approximately 30 lbs. in.

**Note:** Individual carriers may vary slightly.

Pinion bearing preload spacers are available in the following thicknesses 0.286"-0.315" (7.26-8.00 mm). Refer to S135/S150 service parts booklet for kits of commonly used preload spacers.

Always measure each spacer before assembly to ensure correct thickness.

**Note:** Closer adjustment can be made by sanding the next thicker spacer to desired thickness using emery cloth on a flat surface.

**CAUTION:** Wash spacer thoroughly of emery cuttings before installing on pinion.

10. Repeat process until torque to rotate is between 10-40 lbs. in. After proper preload is achieved, remove yoke and install new seal with proper service tool.
11. Install pinion oil seal with proper service tool. (Acceptable torque to rotate is 15-45 lbs. in. when pinion seal is installed.)

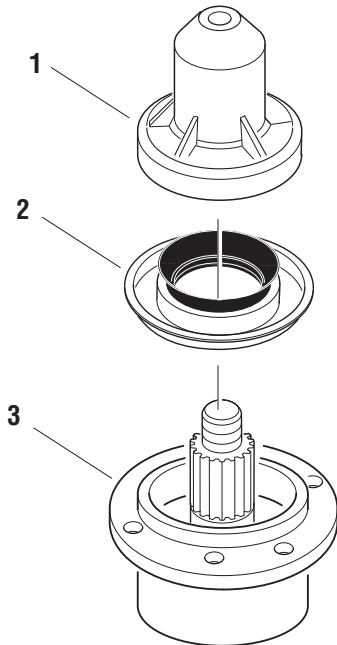

- 1 - Tool
- 2 - Seal
- 3 - Pinion bearing cage

**Note:** Dana strongly recommends using seal drivers when installing new seals. Use the proper driver to ensure the seal is square and installed to the proper depth.

**CAUTION:** Oil seals can be easily damaged prior to installation. Use care when handling the new seal to prevent damage or contamination. Leave the seal in its package until installation. On new yokes, leave the protector on the yoke until it is installed on the shaft to prevent damage or contamination.

12. Install end yoke using yoke installer service tool DST1009.

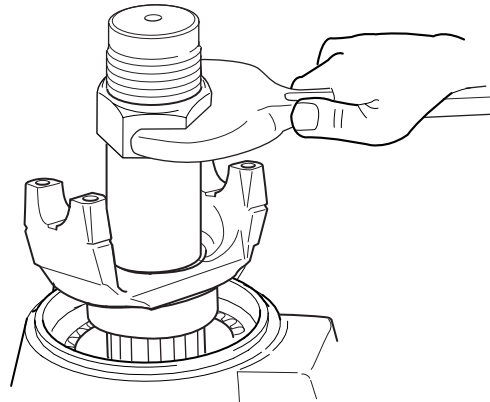

**Note:** Spicer recommends that new torque prevailing nuts be used.

13. Apply Loctite 680 (green) to threads.
14. Use torque multiplier and torque pinion nut to 700-900 lbs. ft. (950-1,220 N•m).

## Wheel Differential Assembly - Exploded View

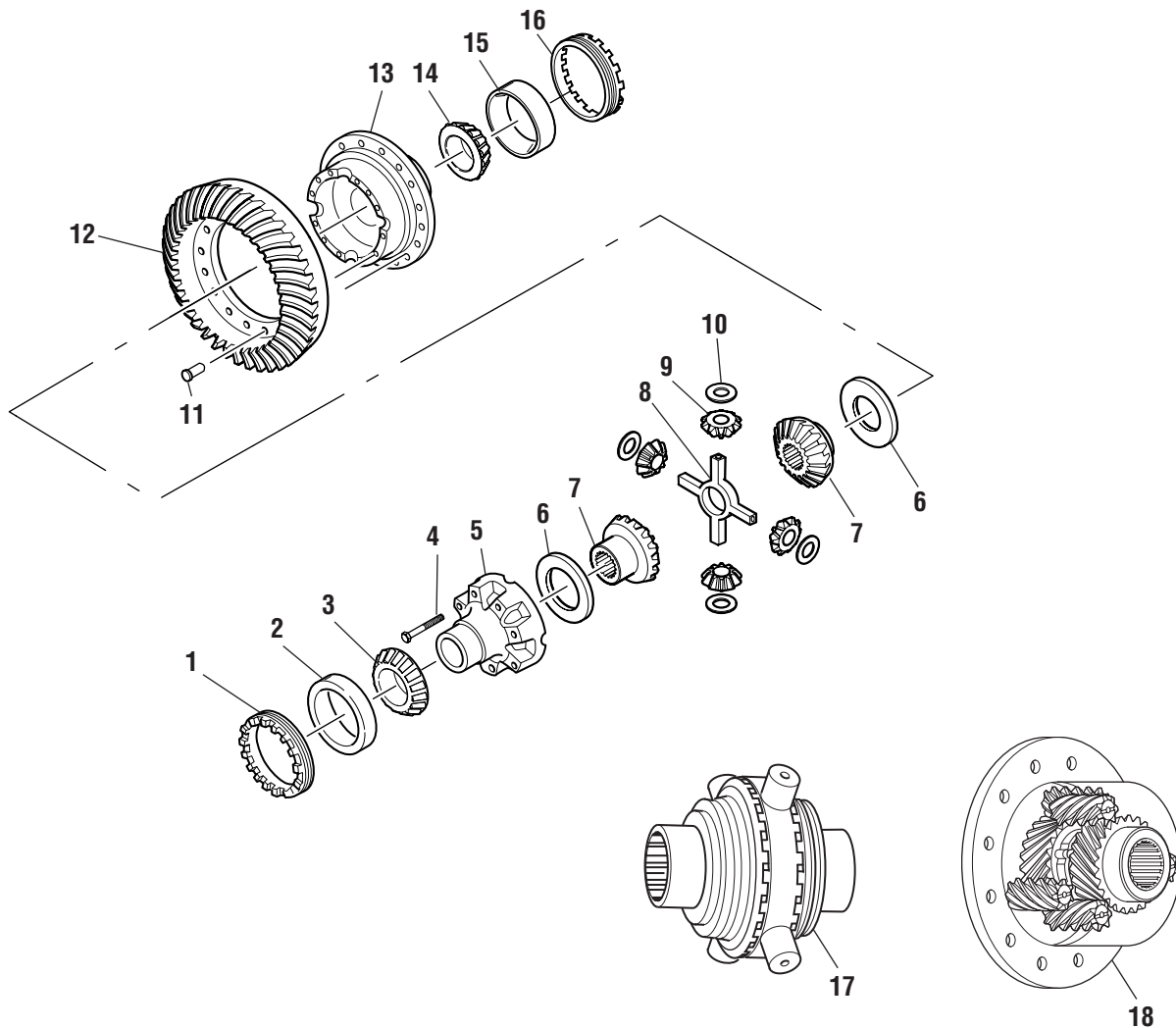

- 1 - Differential bearing adjusting ring
- 2 - Differential bearing cup
- 3 - Differential bearing cone
- 4 - Differential case bolt
- 5 - Differential case half
- 6 - Thrust washer

- 7 - Differential side gear
- 8 - Differential cross shaft
- 9 - Differential pinion mate
- 10 - Thrust washer
- 11 - Ring gear rivet
- 12 - Ring gear

- 13 - Differential case half
- 14 - Differential bearing cone
- 15 - Differential bearing cup
- 16 - Differential bearing adjusting ring
- 17 - No-Spin (optional)
- 18 - Truetrac (optional)

## Disassemble, Overhaul and Assemble Wheel Differential

### Disassemble Wheel Differential



**CAUTION:** During following procedure, place differential assembly on malleable surface to prevent damage when ring gear falls off its mounting position.

**Note:** Inspect all parts, including the machined surfaces of the case half.

If any gears are to be replaced, they must be replaced in sets. Inspect thrust washers for scoring and excessive wear. Replace all worn or damaged parts.

1. When it is necessary to remove ring gear from the differential case, carefully center punch each rivet head. Using a 9/16" drill bit, drill through rivet heads to depth shown. Next, use a rounded type punch to drive out remaining portion of the rivet.

#### Correct Procedure

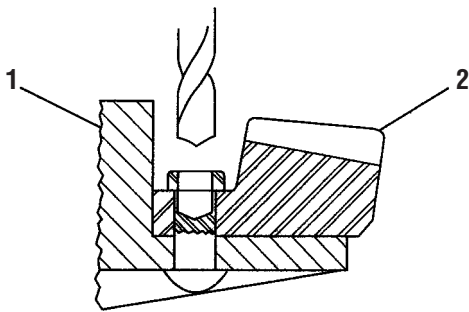

1 - Case  
2 - Ring gear



**CAUTION:** Always use a soft hammer or H.D. plastic head hammer to strike punch.

**Note:** Do not use a chisel to remove rivet heads, damage to differential case may result.

#### Incorrect Procedure

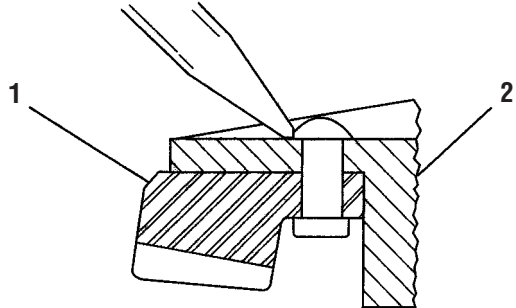

1 - Ring gear  
2 - Case

2. Punch mark differential cases for correct location during reassembly. Remove cap screws and lift off plain differential case half.

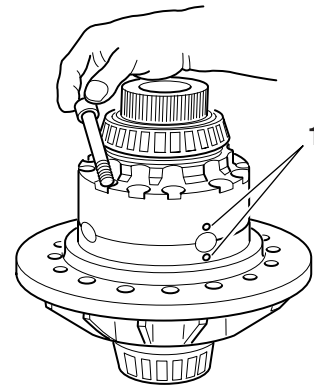

1 - Punch marks

3. Lift out side gear and thrust washer.

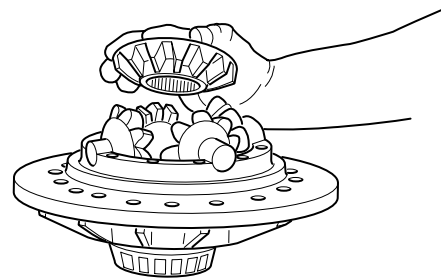

4. Lift out spider, side pinions, and thrust washers.

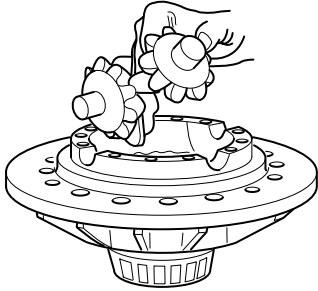

5. Remove remaining side gear and thrust washer.
6. Remove bearing cones from case halves using suitable puller.

7. Remove bearing cone from plain case half in two steps:

- a. Mount puller vertically to split bearing. This action will start moving the bearing off the case.

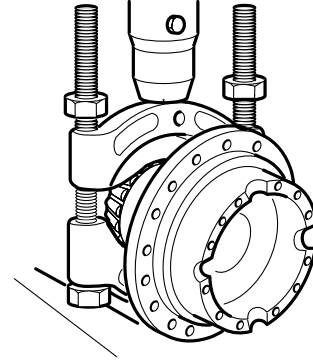

- b. Mount the puller horizontally to remove the cone.

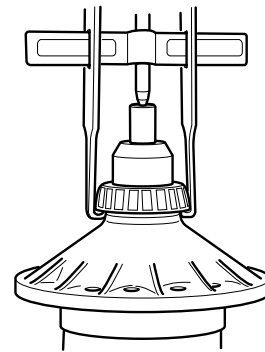

8. Remove the bearing cone from the flanged case half using a suitable puller.

## Overhaul and Assemble Wheel Differential

**CAUTION:** To prevent bearing damage, use suitable sleeve that only contacts the inner race of the cone. A used bearing race would be a suitable tool. This tool should have a slit cut if the ID is the same as the flange OD.

1. Press new flange half bearing cones on differential case halves.

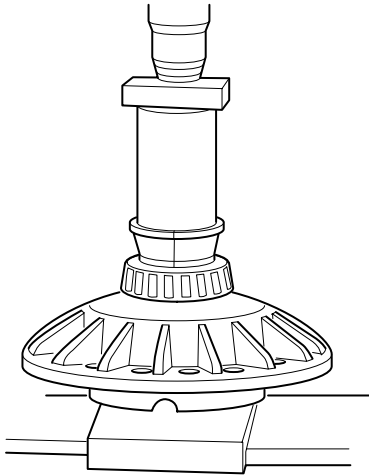

2. Press new plain half bearing cones on differential case halves.

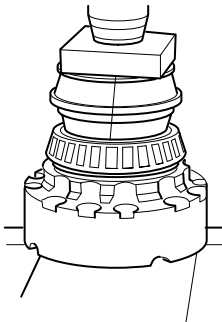

3. Place thrust washer and side gear in flanged differential case.

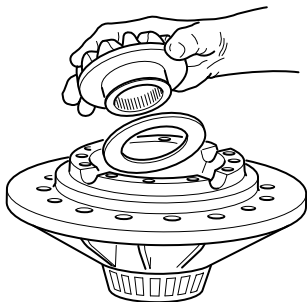

4. Lubricate all differential parts.
5. Assemble side pinion and thrust washers on spider. Place this assembly in flanged differential case. Rotate gears and check for proper mesh.

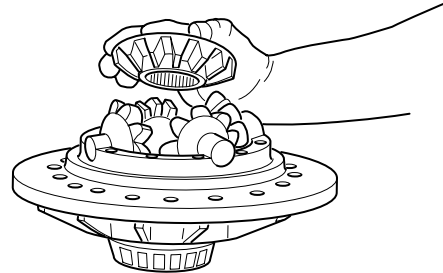

6. Place side gear and thrust washer on side pinions.

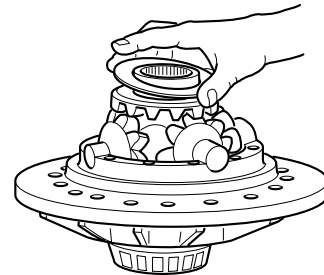

7. Align punch marks and install plain case half. Install cap screws and tighten to proper specifications as outlined in the back of this publication. Check differential for free rotation by turning side gear hub.

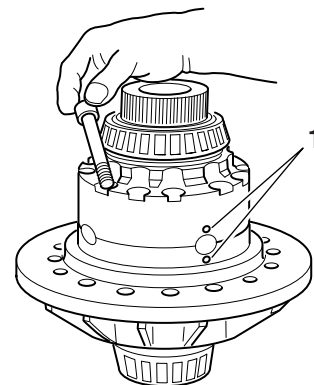

1 - Punch marks

8. Install ring gear. Secure with bolts and nuts.



**Note:** Use the bolt kit 360KY100-X 0.625"-180NF bolt. Torque bolt to 300-320 lbs. ft. (406-434 N•m).

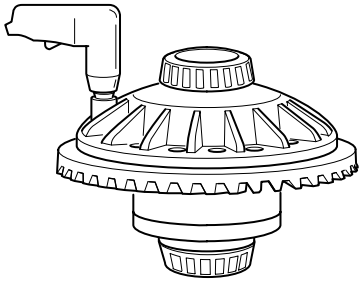

9. Lower assembled differential assembly into the carrier using a hoist and a strap. Be careful not to damage the differential bearings lowering the assembly.

10. Install the bearing cup and bearing adjuster to the flange half side first.

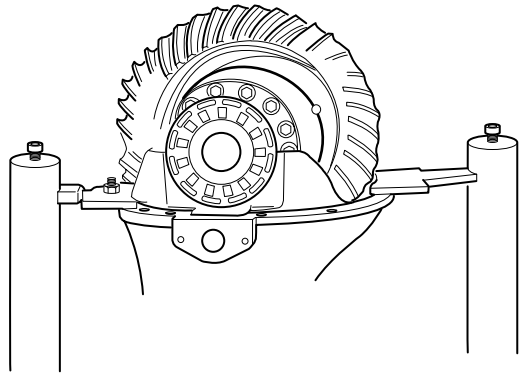

11. Install the bearing cup and bearing adjuster to the plain half side. Use a long screwdriver or bar to lift the differential up while installing the cup and bearing adjuster.

## Measure and Adjust Carrier Assembly (Adjust Backlash and Preload)

1. Turn the flange half bearing adjuster in until the ring gear contacts the pinion (zero backlash) then back the adjuster out two notches of the adjuster lugs.

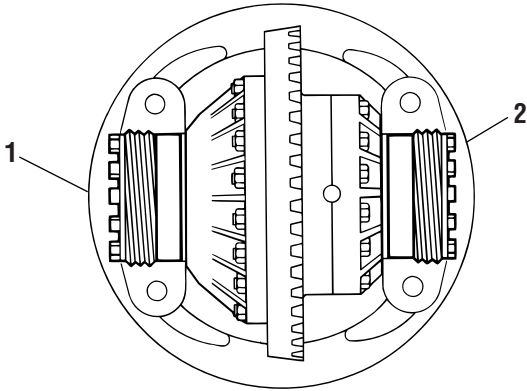

1 - Flange half  
2 - Plain half

2. Tighten the plain half adjuster until the bearing cup just starts to turn, this is a zero bearing preload.

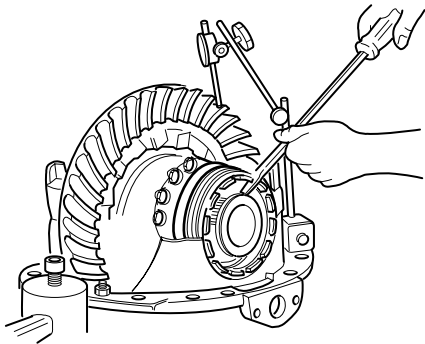

3. Tighten the plain half adjuster two lug notches. Start with the notch at the top, count two notches counterclockwise on the adjuster, and turn the adjuster so the notch is facing straight up. You now have a two notch preload.

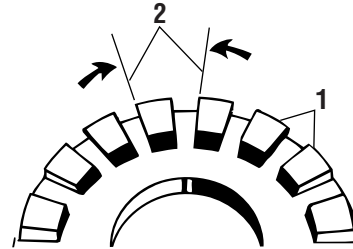

1 - Lugs  
2 - One notch

4. Use a rubber mallet to make certain both bearing adjusters are fully seated.
5. Measure backlash. Make sure it is within specification of 0.008"–0.018".

**TIP:** To give yourself room to adjust contact pattern, set it between 0.010"–0.012".

## Change Backlash Setting

If you have too much backlash the ring gear needs to move closer to the pinion. Back off the plain half adjuster, and count the number of notches you backed it off. Each notch equals about 0.003" of backlash.

**IMPORTANT:** In order to maintain the differential bearing preload you will need to turn the flange half bearing adjuster the same amount in the same direction. If you need more backlash reverse this procedure.

### Recheck Backlash

1. Install carrier bearing caps and torque carrier cap bolts to specifications outlined in the back of this publication.
2. If the bearing adjusters were not in straight or fully seated the backlash will change.
  - a. Used Gearing: Reset to backlash recorded before disassembly.
  - b. New Gearing: Backlash should be between 0.008" and 0.018".

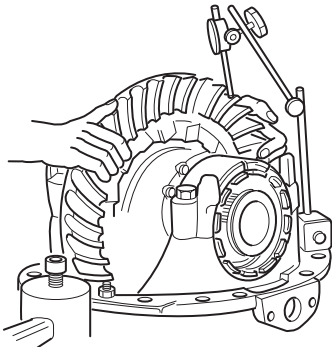

3. Check ring gear tooth contact pattern. Paint ring gear teeth and check tooth contact pattern. Correct tooth patterns. Check adjusting procedures outlined in this section.
4. Install bearing adjuster cotter pins.

## Measure Ring Gear Runout

1. Measure ring gear total radial run out. (Indicator reading should not exceed 0.010").

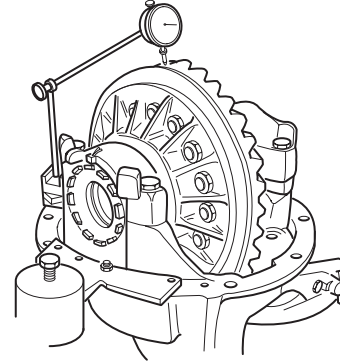

2. Measure ring gear total backface runout. (Indicator reading should not exceed 0.010").

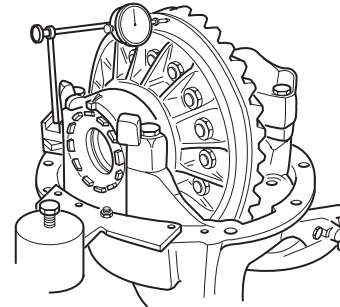

## Adjust Ring and Pinion Tooth Contact Pattern

**Note:** Rear axle gearing is shown in the following instructions. Correct tooth contact patterns and adjustments are the same for forward and rear axles.

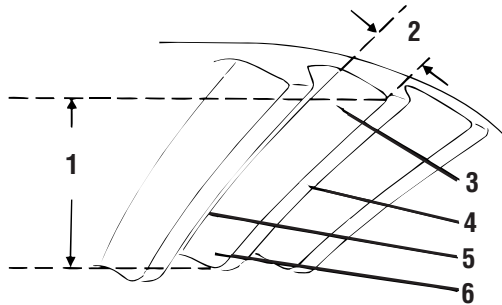

- 1 - Face width
- 2 - Tooth depth
- 3 - Heel
- 4 - Top land
- 5 - Root
- 6 - Toe

1. Identify if new or used gearing.
2. Check tooth contact pattern (new or used gearing).

### New Gearing - Correct Pattern

Paint six ring gear teeth 180° apart with marking compound and roll the gear to obtain a contact pattern. The correct pattern is slightly below center on the ring gear tooth with lengthwise contact up off the toe. The length of the pattern in an unloaded condition is approximately one-half to two-thirds of the ring gear tooth in most models and ratios.

The pattern could vary in length and should cover 1/2 tooth or more (face width). The pattern should be evenly centered between tooth top land and root and should be up off the tooth toe.

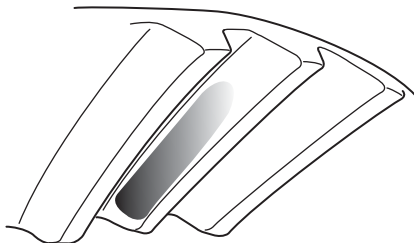

### Used Gearing - Correct Pattern

Used gearing will not usually display the square, even contact pattern found in new gear sets. The gear will normally have a "pocket" at the heel end of the gear tooth. The more use a gear has had, the more the line becomes the dominant characteristic of the pattern.

Adjust used gear sets to display the same contact pattern observed before disassembly. A correct pattern is up off the toe and centers evenly along the face width between the top land and root. Otherwise, the length and shape of the pattern are highly variable and is considered acceptable as long as it does not run off the tooth at any point.

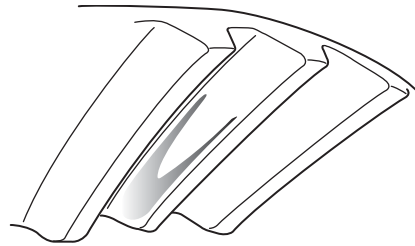

- 1 - Pattern along the face width could be longer

### Adjust Contact Pattern

If necessary, adjust the contact pattern by moving the ring gear and drive pinion.

- Ring gear position controls the backlash. This adjustment moves the contact pattern along the face width of the gear tooth.
- Pinion position is determined by the size of the pinion bearing cage shim pack. It controls contact on the tooth depth of the gear tooth.

These adjustments are interrelated. As a result, they must be considered together even though the pattern is altered by two distinct operations. When making adjustments, first adjust the pinion, then the backlash. Continue this sequence until the pattern is satisfactory.

## Adjust Ring Gear Position (Backlash)

**Note:** Tooth contact pattern can be moved only by adjusting backlash. The tooth contact pattern can be moved in the direction of heel-to-toe, and toe-to-heel; depth of the pattern cannot be adjusted. If an acceptable tooth contact pattern cannot be established within limits of backlash, contact Spicer Service at 1-800-826-HELP (4357).

If the gear pattern shows incorrect face width contact, change backlash by adjusting the ring gear.

If the pattern is too close to the edge of the tooth toe, move the ring gear away from the pinion to increase backlash.

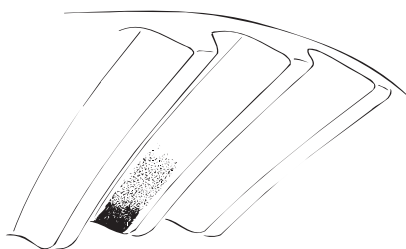

1. Loosen the bearing adjuster on the teeth side of the ring gear several notches.
2. Loosen the opposite adjuster one notch.

3. Return to adjuster on teeth side of ring gear and tighten adjuster until it contacts the bearing cup.
4. Continue tightening the same adjuster 2 or 3 notches and recheck backlash.

If the pattern is concentrated at the heel (too far up the tooth), move the ring gear toward the pinion to decrease backlash.

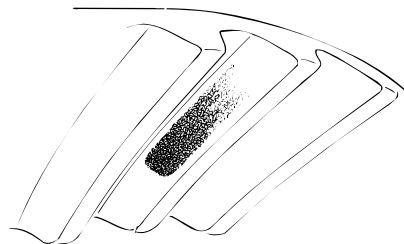

5. Loosen the bearing adjuster on the teeth side of the ring gear several notches.
6. Tighten the opposite adjuster one notch.
7. Return to adjuster on teeth side of ring gear and tighten adjuster until it contacts the bearing cup.
8. Continue tightening the same adjuster 2 or 3 notches and recheck backlash.

## Install New Axle Housing Breather - (Metal and Plastic)

Dana uses an axle housing breather that consists of a fitting, hose, and clamp assembly. This breather design has improved resistance to water ingestion, and clogging caused by dirt, ice, or snow buildup around the base of the breather. See installation instructions below (all views from rear).

1. Install fitting in breather hole.

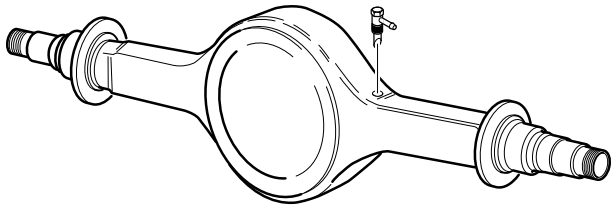

2. Tighten fitting finger tight.

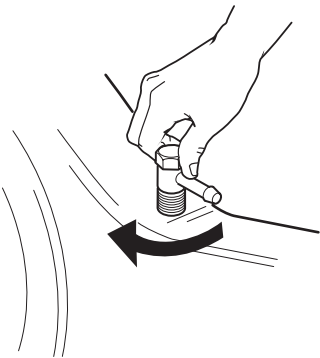

3. Using a 3/4" wrench:

**Metal only:** Rotate the fitting at least 1/2 turn until nipple points to rear.

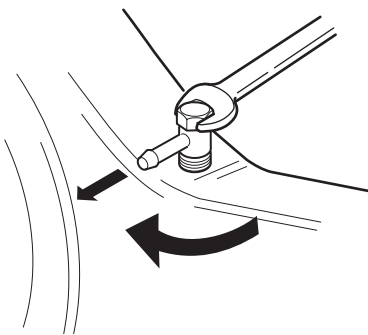

**Plastic only:** Tighten until one thread is showing.

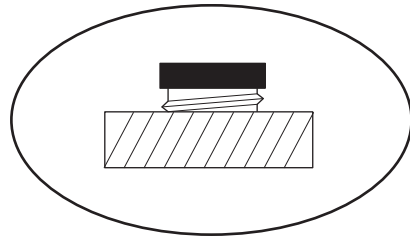

4. Insert hose onto fitting, long end down.

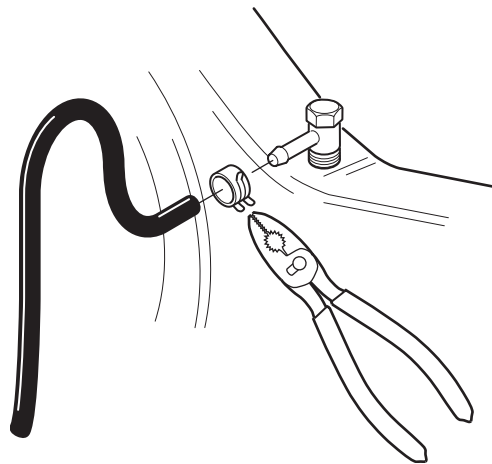

5. Push hose firmly against fitting. Rotate hose to point down.

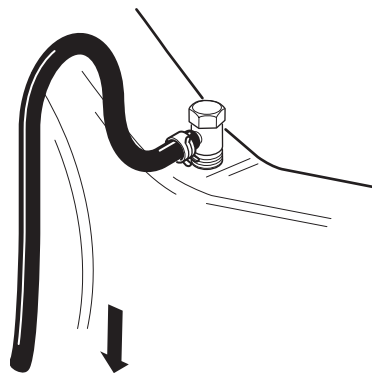

**Axle Housing - Exploded View**

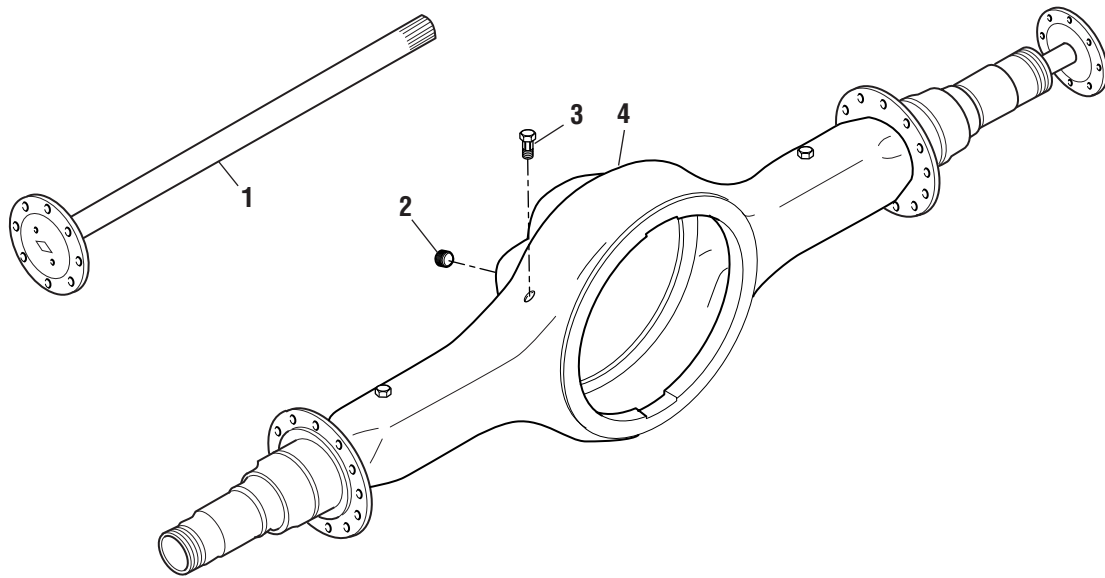

- 1 - Axle shaft
- 2 - Fill plug
- 3 - Breather
- 4 - Housing

## Wheel End Seal Parts - Exploded View

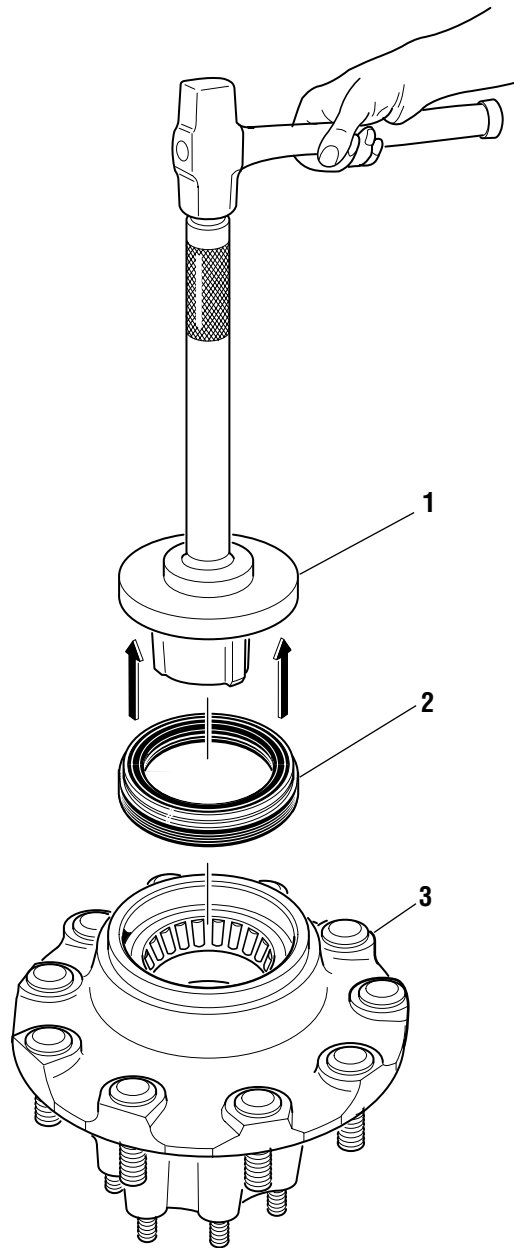

- 1 - Installation tool
- 2 - Seal
- 3 - Rear hub



## Remove and Overhaul Wheel End Seal

 **WARNING:** Never work under a vehicle supported by only a jack. Always support vehicle with stands. Block the wheels and make sure the vehicle will not roll before releasing the brakes.

 **CAUTION:** Wheel end seals can be easily damaged during handling. Leave the seal in its package until installation to prevent damage or contamination.

1. Remove outer bearing and wheel.
2. Remove oil seal.
3. Remove inner bearing.
4. Remove old wear sleeve (2-piece design only) with a ball peen hammer and discard.

 **CAUTION:** Do not cut through the old wear sleeve. Damage to the housing may result.

**Note:** Deep gouges can be repaired by filling gouge with hardening gasket cement and smoothing with emery cloth.

5. Inspect spindle journal and hub bore for scratches or burrs. Recondition with an emery cloth as required.
6. Clean hub cavity and bearing bores before reassembly. Be sure to remove contaminants from all recesses and corners.
7. Clean bearings thoroughly with solvent and examine for damage. Replace damaged or worn bearings.

 **CAUTION:** Always use the seal installation tool specified by the seal manufacturer. Using an improper tool can distort or damage the seal and cause premature seal failure.

## Install Wheel End Seal

1. Before installation, lubricate the following with the same lubricant used in the axle sump:
  - Inner bearing
  - Wheel seal (follow the directions provided by the seal supplier)
2. Place the seal on the installation tool.
3. Drive the seal with the installation tool onto the hub.

## Adjust Wheel Bearing

**WARNING:** Do not mix spindle nuts and lock washers from different systems. Mixing spindle nuts and lock washers can cause wheel separation.

**Note:** The lock washer for a four-piece tang/dowel-type wheel nut system is thinner than the lock washer for a three-piece tang-type wheel nut system and is not designed to bear against the inner nut.

1. Inspect the spindle and nut threads for corrosion and clean thoroughly or replace as required.

**Note:** Proper assembly and adjustment is not possible if the spindle or nut threads are corroded.

2. Inspect the tang-type washer (if used). Replace the washer if the tangs are broken, cracked, or damaged.
3. Install the hub and drum on the spindle with care to prevent damage or distortion to the wheel seal.

**CAUTION:** A wheel dolly is recommended during installation to make sure the wheel seal is not damaged by the weight of the hub and drum. Never support the hub on the spindle with just the inner bearing and seal. This can damage the seal and cause premature failure.

4. Completely fill the hub cavity between the inner and outer bearing races with the same lubricant used in the axle sump.
5. Before installation, lubricate the outer bearing with the same lubricant used in the axle sump.

**Note:** Lubricate only with clean axle lubricant of the same type used in the axle sump. Do not pack the bearings with grease before installation. Grease will prevent the proper circulation of axle lubricant and may cause wheel seal failure.

6. Install the outer bearing on the spindle.
7. Install the inner nut on the spindle. Tighten the inner nut to 200 lbs. ft. (271 N•m) while rotating the wheel hub.

**CAUTION:** Never use an impact wrench to adjust wheel bearings. A torque wrench is required to assure the nuts are properly tightened.

8. Back off the inner nut one full turn. Rotate the wheel hub.
9. Retighten the inner nut to 50 lbs. ft. (68 N•m) while rotating the wheel hub.
10. Back off the inner nut exactly 1/4 turn.

**Note:** This adjustment procedure allows the wheel to rotate freely with 0.001" -0.005" (0.025 mm–0.127 mm) end-play.

11. Install the correct lock washer for the wheel nut system being used.

### Three-piece Dowel-type Lock Washer System

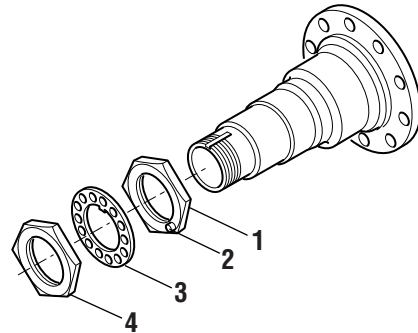

- 1 - Inner nut
- 2 - Dowel pin
- 3 - Dowel-type lock washer
- 4 - Outer nut

- a. Install the dowel-type lock washer on the spindle.

**Note:** If the dowel pin and washer are not aligned, remove washer, turn it over, and reinstall. If required, loosen the inner nut just enough for alignment.

**Note:** Never tighten the inner nut for alignment. This can preload the bearing and cause premature failure.

- b. Install the outer nut on the spindle and tighten to 350 lbs. ft. (475 N•m).
- c. Verify end-play, see "Verify Wheel End Play Procedure".

## Three-piece Tang-type Lock Washer System

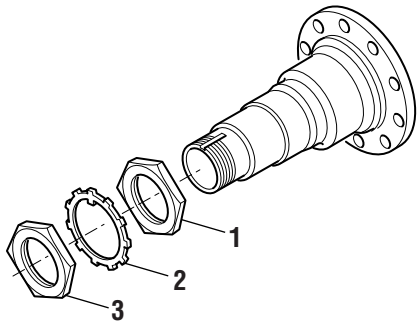

- 1 - Inner nut
- 2 - Tang-type lock washer 0.123" (3.124 mm) thick
- 3 - Outer nut

- a. Install the tang-type lock washer on the spindle.

**Note:** Never tighten the inner nut for alignment. This can preload the bearing and cause premature failure.

- b. Install the outer nut on the spindle and tighten to 250 lbs. ft. (339 N•m).
- c. Verify end-play, see "Verify Wheel End Play Procedure".
- d. After verifying end-play, secure wheel nuts by bending one of the locking washer tangs over the outer wheel nut and another tang over the inner wheel nut.
- e. Go to step 12.

## Four-piece Tang/Dowel-type Lock Washer System

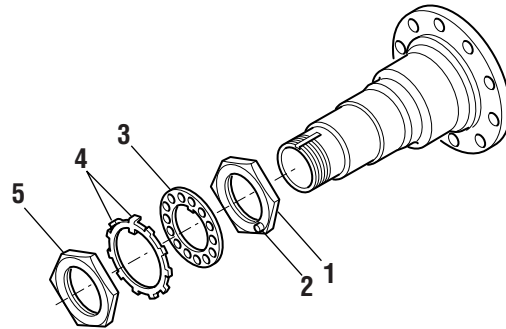

- 1 - Inner nut
- 2 - Dowel pin
- 3 - Dowel-type lock washer
- 4 - Tang-type lock washer 0.0478" (1.2065 mm) thick
- 5 - Outer nut

- a. Install the dowel-type lock washer on the spindle.

**Note:** If the dowel pin and washer are not aligned, remove washer, turn it over and reinstall. If required, loosen the inner nut just enough for alignment.

**Note:** Never tighten the inner nut for alignment. This can preload the bearing and cause premature failure.

- b. Install the tang-type lock washer on the spindle.
- c. Install the outer nut on the spindle and tighten to 250 lbs. ft. (339 N•m).
- d. Verify end-play, see "Verify Wheel End Play Procedure".
- e. After verifying end-play, secure the outer nut by bending two opposing tangs (180° apart) of the locking washer over the outer nut.

12. Install the following:

- New gasket at axle shaft flange.
- Axle shaft.
- Axle flange nuts and tighten to specified torque.

13. Lubricate axle wheel ends.

## Verify Wheel End-Play Procedure

Verify end-play meets specification using a dial indicator. An indicator with 0.001" (0.03 mm) resolution is required. Wheel end play is the free movement of the tire and wheel assembly along the spindle axis.

Correct end-play is 0.001" - 0.005" (0.025 - 0.125 mm).

### Adjust End-Play with Tire and Wheel Assembly

1. Attach a dial indicator with its magnetic base to the hub or brake drum.
2. Adjust the dial indicator so its plunger or pointer is against the end of the spindle with its line of action approximately parallel to the axis of the spindle.
3. Grasp the wheel assembly at the 3 o'clock and 9 o'clock positions. Push the wheel assembly in and out while oscillating it to seat the bearings. Read bearing end-play as the total indicator movement.

**CAUTION:** If end-play is not within specification, readjustment is required.

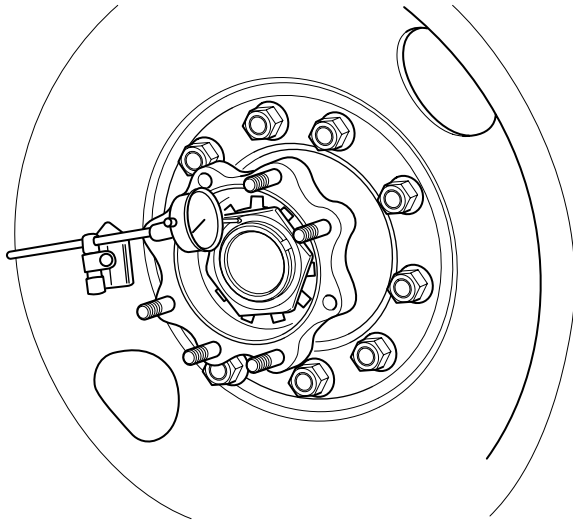

### Adjust End-play with Wheel Hub

**Insufficient End-play** - If end-play is not present, remove the outer nut and pull the lock washer away from the inner nut, but not off the spindle. Loosen the inner nut to the next adjustment hole of the dowel-type washer (if used). Reassemble the washer and re-torque the outer nut. Verify end-play with a dial indicator.

**Excessive End-play** - If end-play is greater than 0.005" (0.127 mm), remove the outer nut and pull the lock washer away from the inner nut, but not off the spindle. Tighten the inner nut to the next alignment hole of the dowel-type washer (if used). Reassemble the washer and re-torque the outer nut. Verify end-play with a dial indicator.

**Fine Tuning the End-play** - If, after performing the readjustment procedures, end-play is still not within the 0.001" - 0.005" (0.025 - 0.127 mm) range, disassemble and inspect the components. If parts are found to be defective, replace the defective parts, reassemble and repeat wheel bearing adjustment procedure. Verify end-play with a dial indicator.

## Lubricate Wheel End

**CAUTION:** Before operating the axle, the wheel hub cavities and bearings must be lubricated to prevent failure.

When wheel ends are serviced, follow Dana's wheel end lubrication procedure before operating the axle.

Dana axles may be equipped with either of two wheel end designs:

- Wheel ends **with** an oil fill hole.
- Wheel ends **without** an oil fill hole.

### Wheel Ends With Oil Fill Hole

1. Rotate the wheel end hub until the oil fill hole is up.
2. Remove the oil fill plug.
3. Pour 1/2 pint of axle sump lubricant into each hub through the wheel end fill hole.
4. Install oil fill plug and tighten to specified torque.

Wheel End with Oil Fill Hole

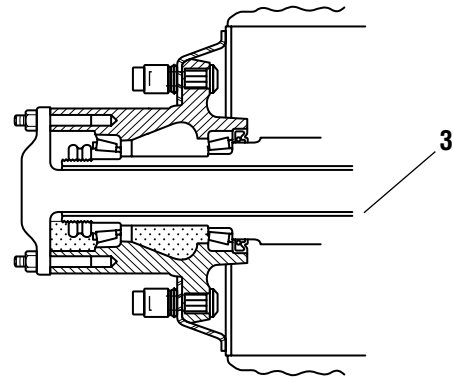
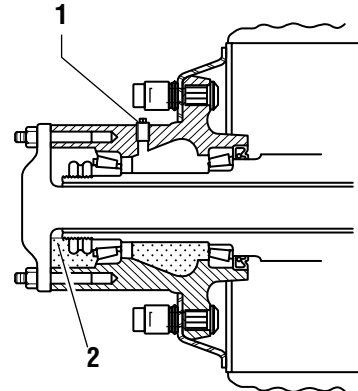

- 1 - Wheel end oil fill hole
- 2 - Proper lubricant level
- 3 - Lubricant flow from sump

## Wheel Ends Without Oil Fill Hole

1. With axle level and wheel ends assembled, add lubricant through filler hole in axle housing cover until fluid is level with the bottom of filler hole.
2. Raise the right side of the axle 6" or more. Hold axle in this position for one minute.
3. Lower the right side.
4. Raise the left side of the axle 6" or more. Hold axle in this position for one minute.
5. Lower the left side.
6. With axle on a level surface, add lubricant through housing cover oil filler hole until fluid is level with the bottom of the hole.

**Note:** Axles without wheel end fill holes will require approximately 2.5 additional pints of lubricant to bring the lube level even with the bottom of fill hole.

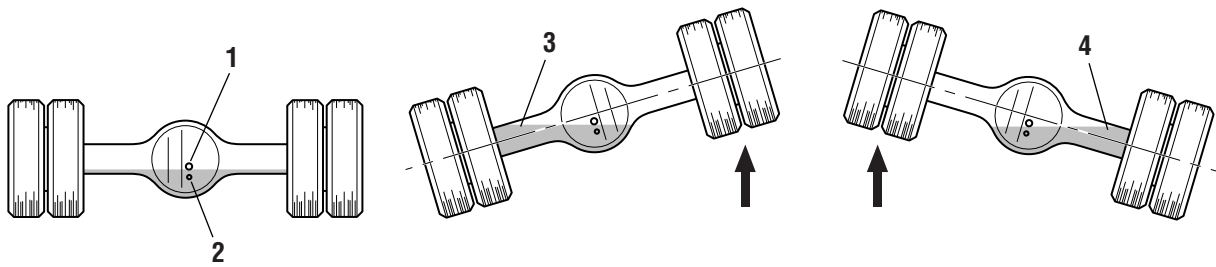

- 1 - Lubricant filler hole
- 2 - Temperature sensor mounting hole
- 3 - Oil will run into wheel end
- 4 - Oil will run into wheel end

## General Lubrication Information

The ability of a drive axle to deliver quiet, trouble-free operation over a period of years is largely dependent upon the use of good quality gear lubrication in the correct quantity. The most satisfactory results can be obtained by following the directions contained in this manual.

The following lubrication instructions represent the most current recommendations from the Commercial Vehicle Division of Dana Corporation.

## Approved Lubricants

**General** - Gear lubrications acceptable under military specification (MILSPEC) MIL-L-2105D (Lubricating Oils, Gear, Multipurpose) are approved for use in Dana Drive Axles. The MIL-L-2105D specification defines performance and viscosity requirements for multigrade oils. It supersedes both MIL-L-2105B, MIL-L-2105C and cold weather specification MIL-L-10324A. This specification applies to both petroleum-based and synthetic based gear lubricants if they appear on the most current "Qualified Products List" (QPL-2105) for MIL-L-2105D.

**Note:** The use of separate oil additives and/or friction modifiers are not approved in Dana Drive Axles.

**Synthetic based** - Synthetic-based gear lubricants exhibit superior thermal and oxidation stability, and generally degrade at a lower rate when compared to petroleum-based lubricants. The performance characteristics of these lubricants include extended change intervals, improved fuel economy, better extreme temperature operation, reduced wear and cleaner component appearance. The family of Dana Spicer™ gear lubricants represents a premium quality synthetic lube which fully meets or exceeds the requirements of MIL-L-2105D. These products, available in both 75W-90 and 80W-140, have demonstrated superior performance in comparison to others qualified under the MILSPEC, as demonstrated by extensive laboratory and field testing. For a complete list of Spicer® approved synthetic lubricants contact your local Dana representative. See back cover of this manual for appropriate phone number.

**Makeup Lube** - Maximum amount of non-synthetic makeup lube is 10%.

## Recommendations for Viscosity/Ambient Temperature

The following chart lists the various SAE Grades covered by MIL-L-2105D and the associated ambient temperature range from each. Those SAE grades shown with an asterisk (\*) are available in the Spicer family of synthetic gear lubricants.

The lowest ambient temperatures covered by this chart are -40°F and -40°C. Lubrication recommendations for those applications which consistently operate below this temperature range, must be obtained through Dana Corporation by contacting your local Dana representative.

GRADE	AMBIENT TEMPERATURE RANGE
75W	-40°F to -15°F (-40°C to -26°C)
75W-80	-40° to 80° (-40°C to 21°C)
75W-90*	-40°F to 100°F (-40°C to 38°C)
75W-140	-40°F and above (-40°C and above)
80W-90	-15°F to 100°F (-26°C to 38°C)
80W-140*	-15°F and above (-26°C and above)
85W-140	10°F and above (-12°C and above)

\* Available in the Spicer family of synthetic gear lubricants.

## Lube Change Intervals

This product combines the latest manufacturing and part washing technology. **When filled with Jëser approved synthetic lubricant at the factory, the initial drain is not required.**

**Change the lubricant within the first 5,000 miles of operation when not using a Jëser approved synthetic lubricant in either a new axle or after a carrier head replacement.** Base subsequent lubricant changes on a combination of the following chart and user assessment of the application and operating environment.

Guidelines - Lube Change Intervals for Drive Axles

LUBRICANT TYPE	ON-HIGHWAY MILES	MAXIMUM CHANGE INTERVAL	ON/OFF HIGHWAY SEVERE SERVICE MILES	MAXIMUM CHANGE INTERVAL
Mineral Based	100,000	Yearly	40,000	Yearly
Spicer Approved Synthetic	250,000	3 Years	100,000	Yearly

**Severe Service Lubrication Change Intervals** - Severe service applications are those where the vehicle consistently operates at or near its maximum GCW or GVW ratings, dusty or wet environments, or consistent operation on grades greater than 8%. For these applications, the ON/OFF HIGHWAY portion of the chart should be used. Typical applications are construction, logging, mining and refuse removal.

**Note:** Clean metallic particles from the magnetic filler plug and drain plugs. Clean or replace the breather yearly to avoid lube contamination due to water ingestion.

For additional lubrication information, see TCMT-0021.



## Change Lube

### Drain

1. Drain when the lube is at normal operating temperature. It will run freely and minimize the time necessary to fully drain the axle, this insures the axle is flushed. Drain into suitable container with lube at normal operating temperature. Inspect drain plug for excessive metal particle accumulation symptomatic of extreme wear. Clean and replace plug after draining
2. Unscrew the magnetic drain plug on the underside of the axle housing and allow the lube to drain into a suitable container.

**Note:** Dispose of all used lubricants properly by following disposal methods approved for mineral or synthetic based oils.

3. After initial oil change, inspect drain plug for large quantities of metal particles. These are signs of damage or extreme wear in the axle. Clean the drain plug and replace it after the lube has drained completely. Inspect breather for clogging or corrosion. Clean or replace as necessary.

**Note:** After initial lube change, the entire unit should be inspected if excessive particle accumulation is observed.

### Fill

1. With vehicle on level ground, remove the filler hole plug from the axle housing cover and fill the axle with approved lubricant until level with the bottom of the hole.
2. If wheel ends were removed, follow instructions in wheel end servicing section.

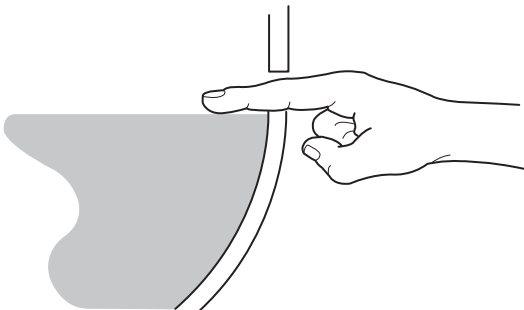

Always use the filler hole as the final reference. If lube is level with the bottom of the hole, the axle is properly filled.

**Note:** Lube fill capacities (see chart) are basic guidelines and will vary based on the angle the axle is installed in a particular chassis. Torque fill plug to 40–60 lbs. ft. (54–82 N•m).

**TIP:** The axle can be filled through the axle housing breather hole. Fill until lube level is even with the bottom of filler hole in axle housing rear cover.

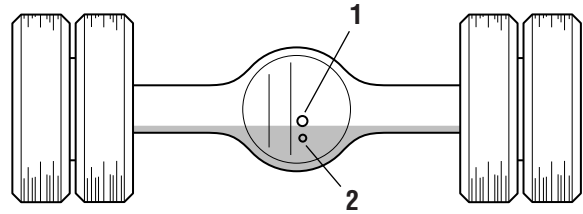

1 - Lubricant filler hole  
2 - Temperature sensor mounting hole

Lube Capacities (Approximate\*) - DO NOT OVERFILL AXLES

MODEL	PINTS	LITERS
S135S / S150S	24.5	11.6
* Lube capacity will vary depending upon the housing angle in each vehicle. Capacities given above are for an angle of 4°. Fill to the lower edge of the fill hole in the axle housing as shown above.		

Axles installed at angles exceeding 6° or operated regularly on grades exceeding 12% may require stand-pipes to allow proper fill levels. For specific information, contact Axle & Brake Engineering Department.

## Proper Vehicle Towing

Lift the drive wheels completely off of the ground or damage will occur.



**WARNING:** Do not lift the front wheels (non-drive wheels). This alters the oil's position in the drive axle, draining it away from the drive pinion and its bearings. If the pinion is rotated under these conditions for any period of time, bearings will overheat resulting in axle damage or failure.

If it is impossible to lift the drive wheels, remove all axle shafts to prevent gear rotation and cap the wheel hubs to prevent loss of lubricant and a possible road hazard. See the following section Proper Vehicle Towing with Wheel Differential Lock for removal procedure.

### With Truetrac Limited Slip Differential

These differentials perform like conventional (open) differentials under normal driving conditions - until traction control is needed. Then the imbalanced gear forces automatically apply resistance to the wheel (or axle) with the lesser traction.

Planetary pinion gears are supported in pockets of the case. Each pinion meshes with its side gear and with a mating pinion of the opposite planetary gear set.

When the vehicle experiences unequal side to side traction (for instance on wet, muddy, icy or sand/gravel terrain), the pinions resist rotation in the case and transfer torque from one side gear to the other. All mating pinions tend to separate from each other and from the side gears and they wedge into their case pockets. This provides a friction force that retards or prevents the wheel with lesser traction from rotating and spinning out.

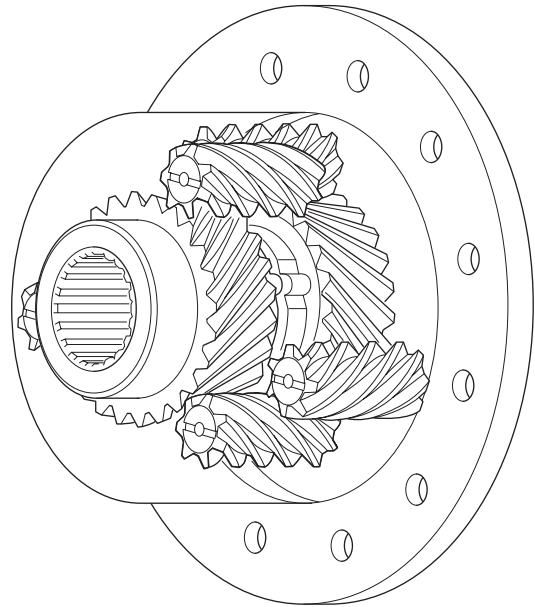

## Torque Flow

While driving with equal load on and equal traction under both drive wheels, the Truetrac differential provides equal torque to each wheel.

With unequal load and/or traction on each drive wheel, a major portion of the torque will be transferred from one side to the other to reduce the chance of a one wheel spin-out.

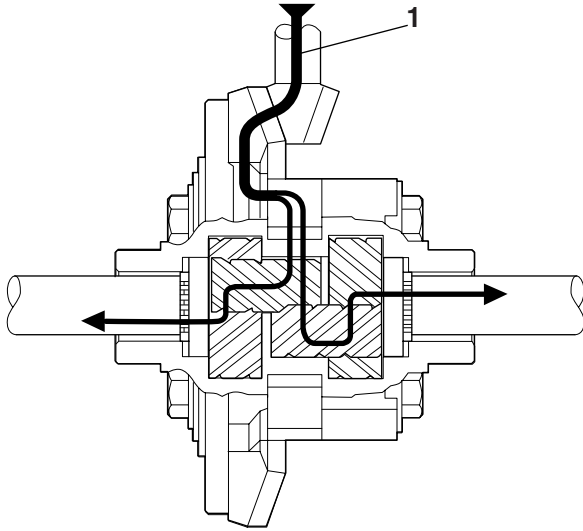

*1 - Torque flow distribution while operating with equal loading and ground coefficient*

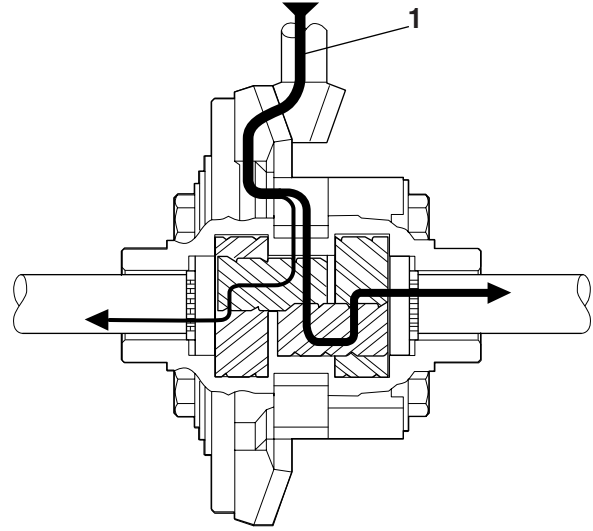

*1 - Torque flow distribution with less load over or ground coefficient under left wheel*

Rear Drive Axle Parts - Exploded View

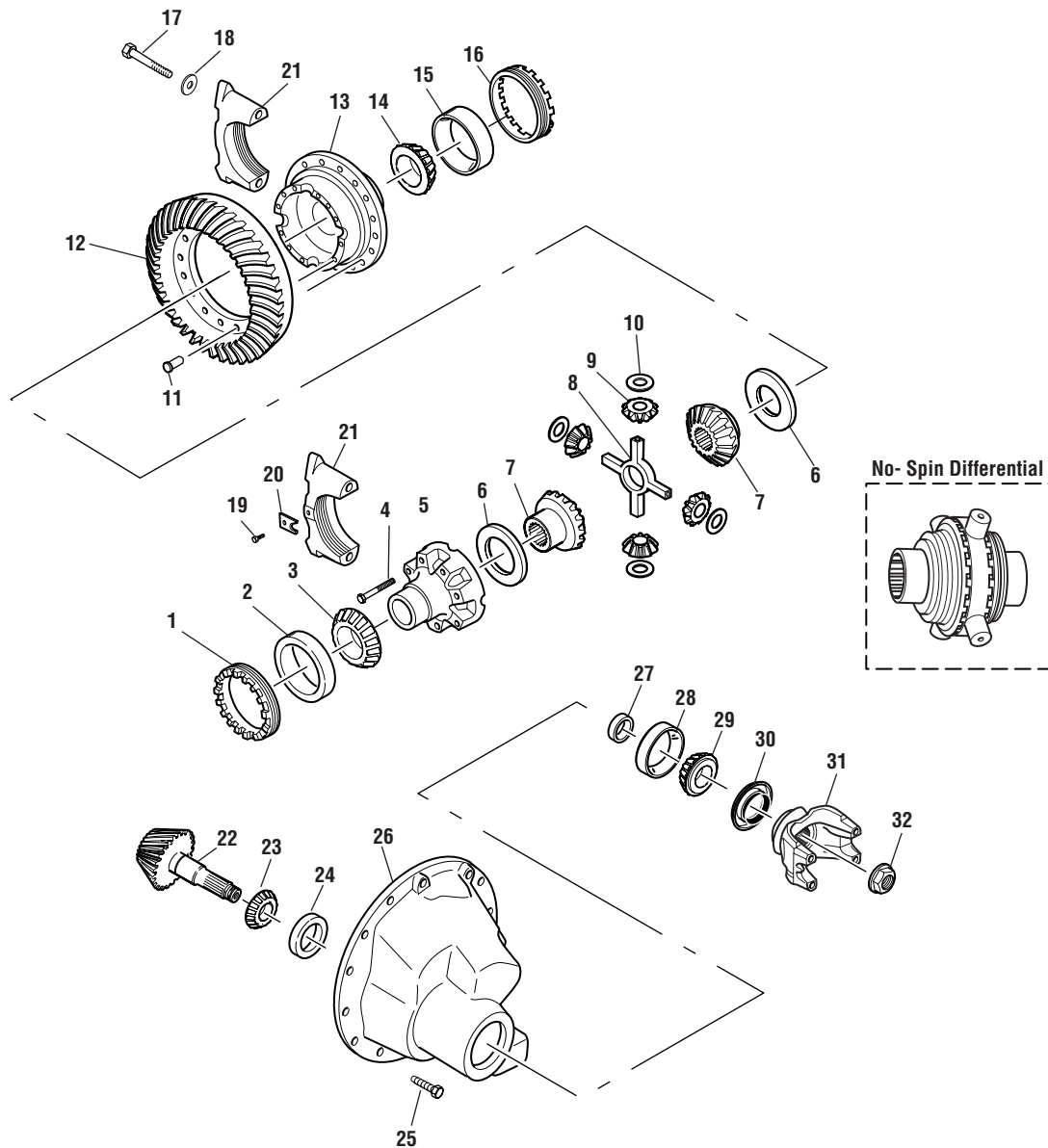

- 1 - Differential bearing adjusting ring
- 2 - Differential bearing cup
- 3 - Differential bearing cone
- 4 - Differential case bolt
- 5 - Differential case half
- 6 - Thrust washer
- 7 - Differential side gear
- 8 - Differential cross shaft
- 9 - Differential pinion mate
- 10 - Thrust washer
- 11 - Ring gear rivet

- 12 - Ring gear
- 13 - Differential case half
- 14 - Differential bearing cone
- 15 - Differential bearing cup
- 16 - Differential bearing adjusting ring
- 17 - Differential bearing cap bolt
- 18 - Washer
- 19 - Adjusting ring lock bolt
- 20 - Adjusting ring lock
- 21 - Differential bearing cap
- 22 - Pinion

- 23 - Inner pinion bearing cone
- 24 - Inner pinion bearing cup
- 25 - Carrier mounting bolt
- 26 - Carrier housing
- 27 - Pinion preload spacer (selective)
- 28 - Outer pinion bearing cup
- 29 - Outer pinion bearing cone
- 30 - Pinon seal
- 31 - End yoke assembly
- 32 - Pinion hex nut

## Fastener Torque Specifications

### S135 / S150 Fasteners

Position	Thread Size	Grade	lbs. ft.	N•m
Pinion Nut	1 1/4" - 12	8	700 - 900	950 - 1,220
Adjusting Ring Lock Bolts	3/8" - 16	8	20 - 30	27 - 41
Carrier Mounting Bolts	1/2" - 13	8	100 - 120	136 - 163
Differential Bearing Cap Bolts	9/16" - 18	8	115 - 135	160 - 183
Differential Cases Bolts	1/2" - 13	8	100 - 120	136 - 163
Fill Plug	3/4" - 14	---	35 - 45	47 - 61
Drain Plug	3/4" - 14	---	35 - 45	47 - 61
Axle Shaft to Wheel Hub Nuts	1/2" - 20	---	55 - 71	75 - 96
	5/8" - 18	---	170 - 190	230 - 258
	3/4" - 16	---	285 - 345	386 - 468

**Note:** Refer to vehicle manufacturer specifications for axle Flange-Wheel Nut Fastener torque.

### S135 / S150 Specifications

Position	U.S.	Metric
Pinion		
Pinion Bearing Preload*	10 - 40 lbs. in.	1.13 - 4.50 N•m
Differential		
Ring Gear to Pinion Backlash	0.006" - 0.012"	0.15 - 0.33 mm
Ring Gear Rivet Pressure	45 - 50 tons	41 - 45 tonnes
Lubrication**		
Lube capacity (Approx.***)	24.5 pints	11.6 liters
* Pinion bearing preload is established prior to installation of pinion seal. ** For additional lubrication information, see TCMT-0021. *** Capacity will vary depending on the housing angle in each vehicle.		

**Recommended Service Tools**

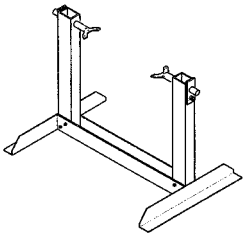
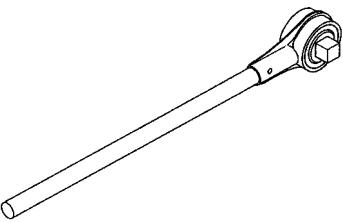
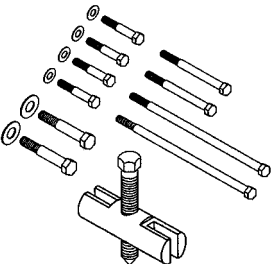
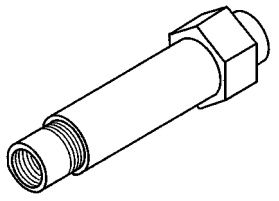
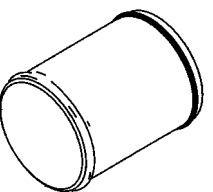
<i>Order Number</i>	<i>Illustration</i>	<i>Description</i>
<i>DST1001</i>		<i>Carrier Stand</i>
<i>DST1002</i> <i>DST1003</i> <i>DST1004</i> <i>DST1005</i>		<i>Torque Multipliers</i> <i>Maximum 1,000 lbs. ft.</i> <i>Maximum 2,000 lbs. ft.</i> <i>Maximum 4,000 lbs. ft.</i> <i>Maximum 12,000 lbs. ft.</i>
<i>DST1006</i>		<i>Yoke Remover, Bar Type</i>
<i>DST1009</i>		<i>Installer, Differential Yoke (1 1/4" - 12)</i>
<i>DST1000-1</i>		<i>Seal Installation Tube Handle</i>

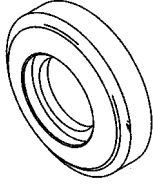
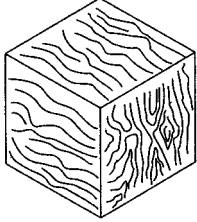
<b>Order Number</b>	<b>Illustration</b>	<b>Description</b>
<b>DST1000-2</b>		<b>Pinion Seal Installer</b>
<b>No Part Number</b>		<b>Wooden Block (Approx. 6" x 6" x 6")</b>

**All service tools available from OTC Division:**

Service Tools  
 655 Eisenhower Drive  
 Owatonna, MN 55060  
 Telephone: 1-800-533-0492  
 Fax Number: 507-455-7011









## **SPICER®**

*Drivetrain Products*

Axles  
Driveshafts  
Off-Highway Transmissions

## **LONG®**

*Thermal Products*

Transmission Oil Coolers  
Engine Oil Coolers

## **VICTOR REINZ®**

*Sealing Products*

Gaskets and Seals  
Cylinder-Head Cover Modules  
Thermal-Acoustic Protective Shielding



Dana Aftermarket Group  
PO Box 321  
Toledo, Ohio 43697-0321

Warehouse Distributor: 1.800.621.8084  
OE Dealers: 1.877.777.5360

[www.spicerparts.com](http://www.spicerparts.com)

# **SPICER®**

