

Tata Indica - V2

XETA LPG

Owner's Manual & Service Book

TATA MOTORS
Passenger Car Business Unit
• Mumbai • Pune •

(This owner's manual is advised to be kept in the vehicle at all times)

-
- Should any question or query exist regarding any aspect of your car, please contact the nearest **TATA MOTORS** dealers, who will be pleased to assist wherever possible.
 - The recommended routine maintenance servicing along with any running repairs that may be required, should be entrusted to **TATA MOTORS** dealerships or to **TATA MOTORS Authorised Service Centres (TASCs)** or **TATA MOTORS Authorised Service Points (TASPs)** to ensure that only latest methods and genuine **TATA MOTORS** replacement parts are used for the continued reliability, safety and performance of the vehicle.
 - In the event of the vehicle being sold, please ensure that this manual is left in the vehicle for the reference of the new owner.
 - This Owner's manual and service book includes information of the operation and maintenance of various equipment installed on the different versions of Tata Indica V2 car. Please note that this manual applies to all the models and explains all equipment including options not installed on your car.

© Copyright 2004 **TATA MOTORS**

All rights reserved. The material in this manual may not be reproduced or copied, in whole or in part, in any form without written permission from **TATA MOTORS**.

Dear Customer,

*Thank you for selecting **Tata Indica V2 XETA LPG** - an Eco Friendly car of your choice*

We welcome you to the world of advanced automotive engineering in a form especially suited to your operating conditions. Tata Indica LPG incorporates the latest generation LPG Injection Technology.

This Supplement gives you all the information necessary for making your ownership of this car a thoroughly satisfying and enjoyable experience.

To assist you in maintaining your car as per recommended schedule, we have a widespread network of dealers and service centres. The list is included in this book for your convenience.

If you need any special assistance, please call on our Regional / Zonal level offices which are also listed in this book.

Please note that by adhering to the correct operating procedures and by availing the scheduled maintenance services at our authorised service centres, you can obtain the maximum performance from your car.

We request you to go through the book and derive many miles of motoring pleasure.

We wish you Safe and Happy Driving

TATA MOTORS LIMITED



CONTENTS

INTRODUCTION	7	MAINTENANCE & CAR CARE	91
24 X 7 ON ROAD ASSISTANCE	8a	<ul style="list-style-type: none">• Engine Compartment Lamp• Windshield Washer• Air Filter • Engine Cooling System• Engine Belt Tension • Oil & Oil Filter• Fuel Filter • Transaxle • Fuel Filling Cap• Clutch & Brakes • Power Steering• Battery • Catalytic Converter• Spark Plug • EGR System (Diesel Engine)• Fuses & Relays • Wheels & Tyres	
VALUE ADDED SERVICE	9	EMERGENCY SERVICE TIPS	129
TAKING CARE OF THE ENVIRONMENT	17	<ul style="list-style-type: none">• Engine • Clutch • Transaxle • Brakes• Steering System • Electrical • Suspension	
We request you to spend a few minutes in going through our environmental concern		IMPORTANT INFORMATION	137
WARRANTY	19	<ul style="list-style-type: none">• Location of Aggregate Numbers• Fuel, Coolants & Lubricants• Technical Specifications• Service Schedule• Car Record Sheet	
INFORMATION AT A GLANCE	21	LIST OF LPG FILLING STATIONS	155
<ul style="list-style-type: none">• Filling Station Information• Car Dimensions		CUSTOMER SUPPORT NETWORK	175
INTRODUCTION - LPG	23	<ul style="list-style-type: none">• Tata Motors Offices & Network• Names & Address of Tata Motors Main Dealers (MDs), Tata Motors Authorised Service Centres (TASCs), Tata Motors Authorised Service Points (TASPs)	
<ul style="list-style-type: none">• Know your Indica LPG • Safety• Compliance to Motor Vehicle rules• Location of LPG system • Location of fuses			
BEFORE DRIVING	33		
<ul style="list-style-type: none">• Controls • Instrument Panel• Heating, Ventilation & Air Conditioning• Interiors and Accessories			
STARTING & DRIVING THE CAR	75		
<ul style="list-style-type: none">• Check List • Starting & Stopping• Preparing to Drive • Fuel Economy• Driving in adverse conditions• Driving Petrol cars • Driving safety			

TATA MOTORS

Rely on us... always.

Call Us : 1 800 209 7979

Mail Us : customercare@tatamotors.com

Visit Us: www.customercare.tatamotors.com



INTRODUCTION

Congratulations on acquiring the **Tata Indica V2 XETA LPG** and welcome to the family of **Tata Indica car** owners.

This owner's manual has been prepared to acquaint you with the operation and maintenance of your new **Tata Indica V2 XETA LPG** and to provide you with important safety information and tips for effective driving. Please refer to it from time to time for enjoyable, safe and troublefree driving pleasure.

This manual is an essential part of your car and should always be kept in the car.

Regular servicing of your car ensures its road worthiness and troublefree operation.

To assist you in maintaining your **Tata Indica V2 XETA LPG** we have a network of dealers and Service Centres throughout the country. The list is included in this manual for your convenience.

Happy motoring

TATA MOTORS

Tata Indica V2 XETA LPG is a safe car designed for quality performance. In order to maintain the level of performance and reliability, it is important that only Tata Motors genuine accessories are to be fitted. Any accessory that is fitted or modification that is carried out without authorisation can hamper the safety & performance of the car besides depriving you of your warranty benefits.

Use of genuine parts, designed and manufactured to our exacting standards, is the best way to maintain your **Tata Indica V2 XETA LPG** in peak operating condition. Please do not use substitutes. They always prove costlier in the long run.

Failure to use genuine parts can invalidate warranty claims.

The information and specifications given in this book are valid as on the date of printing. Tata Motors reserves the right to make changes in design and specifications and/or to make additions to or improvements in this product without obligation to install them on products previously sold.



Indicates "CAUTION"

24X7 ON ROAD ASSISTANCE



Dear Customer,

It is our responsibility and our endeavour to ensure that you have our complete service backup if ever, wherever and whenever you need the same. When you have a road network that spans 33.80 kms, the probability of a breakdown happening within hailing distance of a **TATA MOTORS** Authorized Workshop is very low. It is Precisely for this reason, we have tied up with MyTVS, who will provide breakdown assistance including towing to the nearest **TATA MOTORS** Authorized Workshop through their Authorized Service Providers (ASP)

The **24X7 On Road Assistance** Program shall be automatically available to your vehicle for the duration of Warranty period. The program shall also be available for Extended Warranty period if you avail the same at the time of buying of your vehicle.

Response Time ** for the On Road Assistance Program

Within City Limits	60 minutes
On State or National Highways	90 minutes
Ghat Roads and other places	120 minutes +/-

(The response time will depend on the location, terrain, traffic density and the time of the day.)

Standard procedure when calling for On Road Assistance in case of a breakdown:

- Dial the toll free help line number – **1 800 209 7979**
- Identify your vehicle with the Vehicle chassis number that is available in the Owners Service manual or on the Helpline sticker on the dashboard, near the steering wheel.
- Explain your exact location with landmarks and tell us about the problem you face with the vehicle.
- Park your vehicle on the edge of the road, open the bonnet and put on the hazard warning signal.
- Place the caution sign supplied with the vehicle approx. 3 m from the vehicle in the direction of on coming traffic.

24X7 ON ROAD ASSISTANCE

Coverage under the 24 X 7 On road Assistance Program

- I. The **24x7 On Road Assistance** Program Service covers the following services on your vehicle during warranty period.
- Wheel change through spare wheel.
 - Arrangement of fuel. (Fuel cost will be chargeable at actual cost)
 - Re-opening the vehicle in cases of key lock out.
 - Rectification of electrical problems related to battery, fuses etc.
 - On spot repairs for complaints repairable at site. ^
 - Car to car towing or winching & towing for non accident cases up to a maximum of 15 kms to the nearest Tata Motors authorized workshop. Towing charges at actual cost beyond the same to be paid to the ASP in cash. (Any ferry or toll charges levied in relation to the vehicle being towed to be paid by the customers in actuals in cash).

II. The **24x7 On Road Assistance** Program coverage as indicated above during the extended warranty period of your vehicle is up to a maximum of 3 events for 18/12 months extended warranty period & 4 events for 30/24 months extended warranty period.

III. The **24x7 On Road Assistance** Program as indicated above covers Tata Motors Assured vehicles during the extended warranty period up to a maximum of 3 events.

Exclusions

24x7 On Road Assistance Program does not apply to

- Cost of parts consumables and labour for such repairs not covered under warranty*. These charges are to be settled with ASP in cash.
- Toll or ferry charges paid by ASP in reaching to the breakdown site to be settled with ASP in actuals in cash.
- Cases involving accident, fire, theft, vandalism, riots, lightening, earthquake, windstorm, hail, tsunami, unusual weather conditions, other acts of God, flood, etc.
- Vehicles that are unattended, un-registered, impounded or abandoned.

24X7 ON ROAD ASSISTANCE

- Breakdown/defects caused by misuse, abuse, negligence, alterations or modifications made to the vehicle.
- Lack of maintenance as per the maintenance schedule as detailed in the owner's manual.
- Cases involving racing, rallies, vehicle testing or practice for such events.

Disclaimer

- The service is not available in the states of Arunachal Pradesh, Assam (Except Guwahati City), Meghalaya, Manipur, Mizoram, Nagaland, Sikkim, Tripura, J&K and in Union Territories of Andaman & Nicobar Islands and Lakshwadeep.
- **The reach time is indicative & the actual reach time will be conveyed by the call centre at the time of breakdown call.
- The reach time can vary depending on the traffic density & time of the day.
- The reach time indicated does not account for delays due to but not limited to acts of God, laws, rules & regulations for time being in force, orders of statutory

or Govt. authorities, industrial disputes, inclement weather, heavy down pour, floods, storms, natural calamities, road blocks due to accidents, general strife and law & order conditions viz. fire, arson, riots, strikes, terrorist attacks, war etc.

- ^ On spot repairs at breakdown site shall depend on nature of complaints & will be as per the discretion of the ASP.
- *The decision for free of charge repairs will be as per the warranty policy & procedures of **TATA MOTORS LTD.** and as per the interpretation of the same by ASP. You will be duly informed by the ASP & call centre for the change applicable if any.
- All charges wherever applicable need to be settled directly with the ASP.

24X7 ON ROAD ASSISTANCE

EXCLUSION OF LIABILITIES :

- It is understood that **TATA MOTORS** shall be under no liability whatsoever in respect of any loss or damage arising directly or indirectly out of any delay in or non delivery of, defect/deficiency in service/parts provided by ASP.
- In case vehicle cannot be repaired on-site, customers are advised to use the towing facility for taking their vehicle to the nearest **TATA** authorized workshop only. In no condition will the vehicle be towed to any unauthorized workshop. **TATA MOTORS** will not be responsible for any repairs carried out in such unauthorized workshop.
- Customer are advised to take acknowledgment from the ASP for the list of accessories/extra fittings and other belongings in the vehicle as well as the current condition related to dents/scratches breakages of parts/fitments of the vehicle at the time of ASP taking possession of the vehicle & to verify these items when delivery is taken back by them, Claim for loss of or damage to items, if any should be taken up with ASP directly. **TATA MOTORS** shall not be responsible for any such claims, damages/loss or any deficiency of service of the ASP.
- Vehicles will be handled, repaired & towed as per the customer's risk & **TATA MOTORS** shall not be liable for any damages / claims as a result of the same.
- Services entitled to the customers can be refused or cancelled on account of abusive behaviour, fraudulent representation, malicious intent and refusal to pay the charges for any charges related services and spare parts during service or on previous occasion on part of the customer.
- On site repairs may be temporary in nature. The completion of repairs does not certify the road worthiness of the vehicle. The customer is advised to ensure temporary repairs carried out onsite is followed by permanent repairs at **TATA MOTORS** Authorized Workshop at the earliest.
- Terms and conditions and service coverage, exclusions etc. are subject to change without notice.

Dear Customer,

It is our never ending responsibility and endeavor to ensure that our customer's expectations are fulfilled comprehensively. To fulfill your vehicle service needs, we recommend the following :

- 1) Extended Warranty*
- 2) Anti Rust / Sound Deadening / Engine waxing treatment*
- 3) Iftex Fuel Additive : System D (For diesel) and System G (For Petrol)*
- 4) Car detailing programming : Exterior Enrichment and Interior Enrichment Program*

These products shall help maintain optimum vehicle performance and shall enhance vehicle life.

We have tied up with best in the Class companies, who would bring you the above world class products at affordable prices. The above products are available with all our Dealers, TASCs and TASP.

Our Dealer Service marketing executive shall explain to you the benefits of the above mentioned products.



EXTENDED WARRANTY

Tata Motors recommends the purchase of Extended Warranty, a product of **M/s Global Administration Services and United India Insurance.**

Coverage : Mechanical + Electrical + Emission

Benifits :

- Insures you against unforeseen break down repair bills.
- Documentation is simple and hassle free.
- Near cashless & speedy claim settlement.

Term :

- 18 + 18 or 150000 kms whichever occurs first (For Indica, Indigo & Sumo).
- 18 + 30 or 150000 kms whichever occurs first (For Indica, Indigo, Sumo and Safari Dicor).
- 50000 kms + 50000 kms or 36 months whichever occurs first (For Taxis).
- 50000 kms + 100000 kms or 36 months whichever occurs earlier (for Taxis-Indica, Indigo, Marina).

EMISSION WARRANTY : Emission warranty is limited to the period of the Extended Warranty or 80,000 kms whichever is earlier.

Extended Warranty available in the dealership from where you have purchased your vehicle. We strongly recommend purchase of Extended Warranty at time of purchase of your vehicle. Surcharge applicable on purchase of Extended Warranty after 30 days of purchase of vehicle. The **Dealer Service Marketing Executive** shall explain to you the Terms and conditions, Coverage and Owner's responsibility.

Extended Warranty Booklet & Cover Note :

The Extended Warranty booklet and cover note is the basis of the contract between United India Insurance Co. and the Owner of the vehicle shown on the Extended Warranty Cover note. The Customer to retain this booklet and the same to be produced to the dealer while claiming benefits under Extended Warranty.



Note :

- The 18 / 30 month extended warranty does not follow the 18 month Manufacturer's warranty.
- The extended warranty comes into force once the manufacturer's warranty expires e.g. after 18 Months.
- It is more restrictive as by the time it comes into force the vehicle is already 18 months old.

What is covered ?

- Mechanical / Emission / Electrical break down as defined in this warranty and confirmed by the dealer within the stipulated terms and conditions.
- Tata Motors dealer shall either repair or replace any part found to be defective with a new part or an equivalent at no cost to the owner for parts or labour.
- Such defective parts which have been replaced will become property of United India Insurance Company.
- Comprehensive list of parts covered is mentioned in the page 9-12 of the Extended Warranty Booklet.

What is not covered ?

Pages 6 – 7 of the Extended Warranty Booklet provided details of the exclusion list.

Owner's Responsibility :

- Proper use, maintenance and care of the vehicle in accordance with the instructions contained in the Owner's Manual and Service Booklet. The records of the same to be ensured in Owner's Manual.
- Retention of maintenance service bills.
- Always produce extended warranty booklet while servicing & claim in a warranty..

I / We have been explained the Terms and conditions, Coverage and Owner's responsibility by the Dealer Service Marketing Executive.

I wish to avail / Do not wish to avail extended warranty

Customer's Sign

Dealer's Sign

FUEL ADDITIVES

IFTEX: Triple action diesel additive :

One Additive, multiple benefits

- For diesel cars: Iftex System D
- For Petrol cars: Iftex System G

Benefits:

- Cleans injector and fuel system.
- Maintains peak engine performance.
- Saves diesel / petrol and maintenance cost.
- Reduces smoke and harmful emission.
- Helps Smooth running of the engine
- Reduces deposit on intake manifold and combustion chamber.
- Reduces deposit on injector tips.

**Approved for use in TATA INDICA, INDIGO, SUMO & SAFARI
TREAT YOUR CAR TO EXPERIENCE, THE ULTIMATE PERFORMANCE**

Directions of use :

- Remove cap, squeeze lightly till dispenser fills to 10 ml mark. Add before filling up the tank.
- Use at the rate of 1 ml per litre of fuel. For best results, regular use is recommended.

I / We have been explained the Terms and conditions, Coverage and Owner's responsibility by the Dealer Service Marketing Executive.

I wish to use / Do not wish to use this treatment

Customer's Sign

Dealer's Sign



Why are Corrosion Protection Waxes necessary?

Corrosion is caused by:

Water / salt water acid rain & atmospheric fallouts.

Critical areas are:

Cavities: joints, crevices, spot welds, underbody

- Corrosion is the most important factor when we talk about the vehicle life. If you treat your car you can prolong the life.
- It is very dangerous to drive around in a corroded car.
- The corrosion creeps onto the car from the inside and from the outside. The most dangerous kind of corrosion is often not discovered until it is too late.

Benefits of Anti -Rust treatment :

- A professionally applied range of world class products offering real value to the new and used car customer.
- The treatment has been developed to withstand the harshest environmental and climatic conditions (rust, Pollutants, stone and gravel impact, etc)
- Insulate cabin space from external noises.
- Expensive tin work and Denting / Painting avoided.
- Higher resale value for the car.
- Higher safety – uncorroded vehicle
- Upto 60 months warranty & 10 free checkups available



ANTI RUST, SOUND DEADENING & ENGINE WAXING

Engine Wax Treatment :

Engine Wax is a beige coloured transparent lacquer coating on the engine compartment.

- Corrosion Prevention for the Engine compartment
- Neat, clean and New Look to Engine compartment
- No effect on MPFI vehicles
- Engine wax can withstand upto 200 degrees temp
- No need of cleaning the engine compartment with diesel once engine wax is sprayed
- Life of over a year

Sound Deadening System :

Door vibration deadeners - These pads when stuck on the insides of the sheet metal increase sheet metal rigidity, reduce vibrations and increase riding comfort.

- Used for reducing the sheet metal vibration in a vehicle.
- Product to be used once in the life of the vehicle - Life Time Warranty
- Effect is Life long i.e. until & unless pads are physically removed.
- Negligible increase in Weight & hence no effect on fuel consumption.
- Areas covered - four doors, rear quarter panels & dicky. In case of diesel vehicles, can be used in the bonnet.

Tata Motors has tied up with **M/s Wuerth and M/s STS Chemicals (Dinitrol)** for this world class treatment at affordable prices. This treatment is available in all authorized workshops. The Dealer Service Marketing Executive will explain to you the benefits and terms and conditions of this treatment.

I / We have been explained the Terms and conditions, Coverage and Owner's responsibility by the Dealer Service Marketing Executive.

I wish to avail / Do not wish to avail these treatment

Customer's Sign

Dealer's Sign

Vehicle Exterior Enrichment :

Why vehicles are painted?

- For Corrosion protection of the metal surfaces.
- Ease of application from other corrosion protection treatments.
- Cheaper than other corrosion protection methods eg.galvanizing, anodizing.
- For decoration and identification.

Various Environmental Hazards affecting paints :

- Environmental hazards: destroy your vehicle's finish.
- Even as your new vehicle rolls off the assembly line, the paint is not protected.

The enemy :

Ultraviolet Rays, Pollution, Tree Sap, Bird Droppings, Car Wash Chemicals, Road Salt, Acid Rain.

Benefits: Vehicle Exterior Enrichment

- Removal of medium scratches, orange peel, oxidation , dust nibs etc & swirl marks from painted surface.
- Restoration of original gloss levels UV protection after gloss is restored.
- Cleaning & dressing of tyres, Bumpers & all exterior plastic moldings/trims.

Tata Motors has tied up with **M/s Opulent (Waxoyl brand)** and **M/s 3M** for this world class treatment at affordable prices. This treatment is available in all authorized workshops. The Dealer Service Marketing Executive will explain to you the benefits and terms and conditions of this treatment.



EXTERIOR AND INTERIOR ENRICHMENT PROGRAM

Vehicle Interior Enrichment

Why protect your new car's fabric interior ?

- Someone will soil your vehicle's fabric carpet or seats.
- A significant detractor from your vehicle's resale value.
- A permanent stain on your vehicle's interior fabric.

The enemy :

Drink Spills - Food Stains - Mud - Ultraviolet Rays Pets - Traffic

Benefits: Vehicle Interior Enrichment

- Removal of medium stains and dirt from all interior parts of the car i.e carpet, upholstery and roof lining.
- Cleaning of windshield and all windows (inside and outside)
- Dressing of all internal plastics (eg: door pad trims)and rubber parts.
- The treatment involves cleaning and dressing of All parts of the exposed interiors.
- Specialised protection for seat fabric from liquid spills.

Tata Motors has tied up with **M/s Opulent (Waxoyl brand and M/s 3M** for this world class treatment at affordable prices. This treatment is available in all authorized workshops. The Dealer Service Marketing Executive will explain to you the benefits and terms and conditions of this treatment.

I / We have been explained the Terms and conditions, Coverage and Owner's responsibility by the Dealer Service Marketing Executive.

I wish to avail / Do not wish to avail these treatment

Customer's Sign

Dealer's Sign

ENVIRONMENTAL PROTECTION

Taking Care of the Environment

Taking care of the Environment

Tata Motors is committed to producing cars using environmental friendly technology. A number of features have been incorporated in our passenger cars which are specifically designed to ensure environmental compatibility throughout the life cycle of the car. We would like to inform you that your car meets Emission norms and is being regularly validated at the manufacturing stages to keep up with the stringent emission norms.

As a user you too can protect the environment by operating your car in a proactive manner. A lot depends on your driving style and the way you maintain your car. Listed below are few tips that will help you do so.

WHILE DRIVING :

- Avoid frequent and violent acceleration.
- Do not carry any unnecessary weight on the vehicle as it overloads the engine.
- Avoid using devices requiring high power consumption during slow traffic condition.
- It is not advisable to warm up the engine during the first start of the day by idling, as cold temperatures

within the engine could cause rise in the emission such as CO & HC particulate.

- Monitor the car's fuel consumption regularly. If it shows a rising trend get the car immediately attended to at the TATA MOTORS Authorised Service Centre.
- Switch off the engine during long stops at traffic jams or signals. If you need to keep the engine running, avoid unnecessarily revving or stopping and starting.
- Use only **unleaded fuel** in petrol cars.
- It is not necessary to rev up the engine before turning it off as it unnecessarily burns the fuel.
- For petrol cars switch off the ignition only when engine is at idling and when the vehicle is stationary, not when the vehicle is running.
- Shift to higher gears as soon as it is possible. Use each gear upto 2/3rd of it's maximum engine speed. A chart indicating gear shifting speeds is given in this book.

MAINTENANCE OF THE CAR :

- Ensure that recommended maintenance is carried out on the car regularly at the TATA MOTORS Authorised Service Outlets.

ENVIRONMENTAL PROTECTION

- As soon as you notice any leakage of oil or fuel in the car we recommend that you get it attended immediately.
- Use only recommended brands and grades of lubricants & coolants and clean/uncontaminated fuels.
- Get your vehicle checked for emission periodically by our authorised dealer and regularly renew the P.U.C. Certificate.
- Ensure that fuel filter, oil filter, breathers are periodically checked and if required, replace the same using only genuine recommended brands.
- Do not pour used oils or coolants into sewage drains, garden soil or open streams. Dispose of the used filters and batteries in compliance with the current legislation.
- Do not allow any unauthorised person to tamper with the engine settings or to carry out modifications on the car.
- Never allow the vehicle to run out of fuel. This will result in misfiring of the engine and could cause harm to the catalytic converter.

Taking Care of the Environment

- Parts like brake liners and clutch disc should be vacuum cleaned. Do not use compressed air for cleaning these parts which may spread the dust in the atmosphere.

While carrying out the servicing or repairs of your car, you should pay keen attention to some of the important engine aggregates which greatly affect emission. These components are :-

1. **Fuel pump, Injectors / LPG Fuel System**
2. **Air intake & Exhaust system especially for leakages**
3. **Cylinder head for valve leakage**
4. **All filters such as air, oil & fuel filters (check periodically)**
5. **Catalytic converter**
6. **Ignition system - Spark plug gap**

This Owner's Manual & Service Book contains further information on driving precautions and maintenance care leading to environment protection. Please familiarise yourself with these aspects before driving.

WARRANTY

We WARRANT each **Tata Indica Xeta LPG** car and parts thereof manufactured by us to be free from defect in material and workmanship subject to the following conditions -

1. This warranty shall be for 18 months from the date of sale of the car irrespective of the distance covered. However, for the cars used for commercial applications (used for hire or reward viz those operating with a yellow number plate), the warranty shall be limited to 18 months or 50,000 kms, whichever occurs earlier.
2. Our obligation under this warranty shall be limited to repairing or replacing, free of charge, such parts of the car which, in our opinion, are defective, on the car being brought to us or to our dealers within the warranty period. The parts so repaired or replaced shall also be warranted for quality and workmanship but such warranty shall be co-terminus with this original warranty.
3. Any part which is found to be defective and is replaced by us under the warranty shall be our property.
4. As for such parts as tyres, batteries, electrical equipment, fuel injection equipment, etc. not manufactured by us but supplied by other parties, this warranty shall not apply, but buyers of the car shall be entitled to, so far as permissible by law, all such rights as we may have against such parties under their warranties in respect of such parts.
5. This warranty shall not apply if the car or any part thereof is repaired or altered otherwise than in accordance with our standard repair procedure or by any person other than from our sales or service establishments, our authorised dealers, service centres or service points in any way so as, in our judgement which shall be final and binding, to affect

Terms and Conditions

its reliability, nor shall it apply if, in our opinion which shall be final and binding, the car is subjected to misuse, negligence, improper or inadequate maintenance or accident or loading in excess of such carrying capacity as certified by us, or such services as prescribed in our Owner's Manual and Service Book are not carried out by the buyer through our sales or service establishments, our authorised dealers, service centres or service points.

6. This warranty shall not cover normal wear and tear or any inherent normal deterioration of the car or any of its parts arising from the actual use of the car or any damage due to negligent or improper operation or storage of the car. This warranty shall not apply to normal maintenance services like oils & fluid changes,

WARRANTY

head lamps focussing, fastener retightening, wheel balancing, tyre rotation, adjustment of valve clearance, fuel timing, ignition timing and consumables like bulbs, fuel filters & oil filters, etc. This warranty shall not apply to any damage or deterioration caused by environmental pollution or bird droppings. This warranty shall not apply to V-belts, hoses and gas leaks in case of air conditioned cars. Slight irregularities not recognised as affecting the function or quality of the vehicle or parts, such as slight noise or vibration, defects appearing only under particular or irregular operations are items considered characteristic of the vehicle.

7. This warranty shall be null and void if the car is subjected to abnormal use such as rallying, racing or participation in any other competitive sport. This warranty

shall not apply to any repair or replacements as a result of accident or collision.

8. This warranty is expressly in lieu of all warranties, whether by law or otherwise, expressed or implied, and all other obligations or liabilities on our part and we neither assume, nor authorise any person to assume on our behalf, any other liability arising from the sale of the car or any agreement in relation thereto.
9. The buyer shall have no other rights except those set out above and have, in particular, no right to repudiate the sale, or any agreement or to claim any reduction in the purchase price of the car, or to demand any damages or compensation for losses, incidental or indirect, or inconvenience or consequential damages, loss of car, or loss of time, or otherwise, incurred or accrued.

Terms and Conditions

10. Any claim arising from this warranty shall be recognised only if it is notified in writing to us or to our authorised dealer without any delay soon after such defects as covered and ascertained under this warranty.
11. This warranty shall stand terminated if the car is transferred or otherwise alienated by the buyer without our prior written consent.
12. We reserve our rights to make any change or modification in design of the car or its parts or to introduce any improvement therein or to incorporate in the car any additional part or accessory at any time without incurring any obligation to incorporate the same in the cars previously sold.



INFORMATION AT A GLANCE

Filling Station Information

ENGINE OIL UPTO DIPSTICK MAX.MARK ~ 4.0 Ltrs.

FUEL TANK CAPACITY

PETROL 37 Ltrs.
LPG 31 Ltrs.

* Premixed ready
to use Engine
Coolant = 6 Litres

Windshield Washer
reservoir Capacity= 3.5
Litres (for GLX) and 1.5 Litre
(for GL/GLE/GLS/GLG)

Brake fluid = 0.265 Litres

TRANSAXLE OIL

3.3 Ltrs.

TYRE PRESSURE

33 PSI (2.3 bar) / 30 PSI (2.1 bar)
FRONT / REAR

IMPORTANT : For petrol cars fitted with catalytic converter always use only unleaded petrol with an octane rating not less than RON 87.

For recommended oil grades and change intervals, refer lubricants chart and service schedule

INFORMATION AT A GLANCE

Dimensions

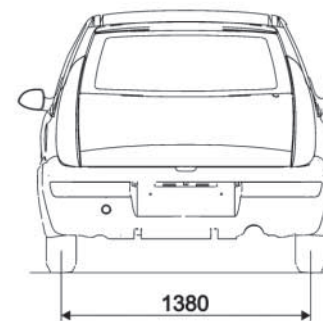
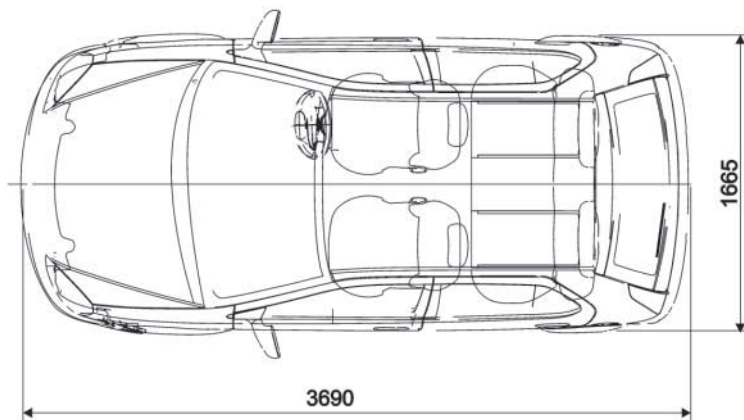
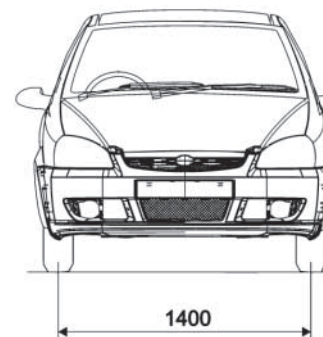
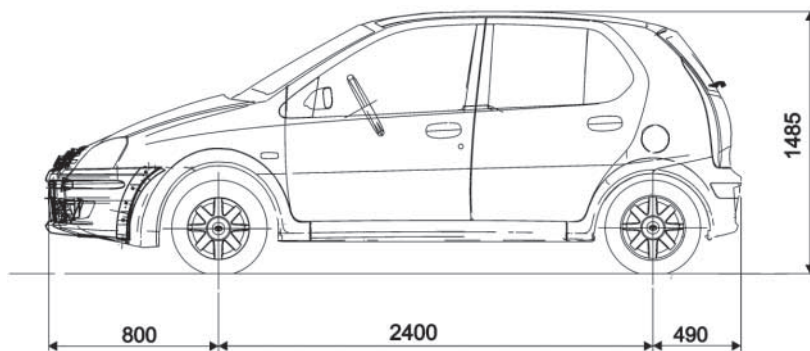

Note : Co-driver's side rear view mirrors for Deluxe version only.



INTRODUCTION - LPG

- **INTRODUCTION - LPG**
- **KNOW YOUR INDICA LPG**
 - Starting the engine
 - Fuel (LPG) filling
 - Running on LPG
 - Fuel Selector Switch
 - Shifting the fuel mode
 - Do's and Dont's
- **SAFETY**
 - In case of gas leakage
 - Fire Extinguisher
 - Manual shut off knob / lever
 - Level Indicator
- **COMPLIANCE TO MOTOR VEHICLE RULES**
- **LOCATION OF LPG SYSTEM COMPONENTS**
- **LOCATION OF FUSES**

INTRODUCTION

In addition to the full capacity of petrol the Indica Xeta now comes with LPG as additional fuel choice.

WHAT IS LPG?

LPG or Liquefied Petroleum Gas is a safe and environment friendly fuel. It is a liquid under pressure and turns into gaseous state when exposed to the atmospheric pressure.

LPG is a non-toxic, non-corrosive; lead-free gas and is produced by refinery fractionation of oil or is stripped from naturally occurring Natural Gas.

LPG fuel system and the components are as safe as those in other fuel systems.

For LPG operation, press the Fuel Selector Switch provided on the dashboard. The fuel change over happens automatically.

The switching between fuels (Petrol-LPG-Petrol) can be done at any time, even on the move.

Your car starts in petrol / auto mode when the engine is cold. Hence it is essential to have at least 10 litres of petrol at all times to ensure trouble free operation.

WARNING

DO NOT USE DOMESTIC GAS CYLINDERS IN CAR because...

- Domestic cylinders are **NOT** designed for Car application and this makes them vulnerable in a crash situation.
- The chemical composition of domestic LPG is different from that of Auto LPG, which may lead to premature failure of engine and its related components
- The gas outlet 'valve' arrangement on the domestic cylinder doesn't meet the car fuel supply standards and hence makes them more dangerous in the car. For example the valve is not provided with excess flow protection. This means that if the valve or supply line gets disconnected in a crash situation, there will be an uncontrolled flow of LPG into the car interior.
- When using domestic gas cylinder, your car's engine gets less supply of fuel when load on engine is increased (e.g. while climbing a ghat). This is because the cylinder cannot supply adequate LPG from the tank to the engine.

STARTING THE ENGINE

Irrespective of the position of the fuel selector switch (Petrol or LPG), your car's engine will start using petrol when the engine is cold and later switch over to LPG once the engine warms up (if LPG mode is selected).

Starting time in LPG will be longer than in petrol due to the physical characteristics of the fuel.

To start, turn the ignition "ON", press the clutch pedal fully and crank. Do not press the accelerator pedal.

NOTICE

The Starter Protection System fitted in this car does not allow you to crank the engine until you press the clutch pedal fully.

NOTICE

The Starter Protection System switches off the starter when it is cranked for more than 10 secs. In such a case, get the key back to OFF position and wait for 30 secs before cranking again. This safeguards the starter motor as cranking continuously for more than 10 secs can damage the starter motor. Also immediately release the key after the engine has started, otherwise the flywheel ring/ starter motor may get damaged.

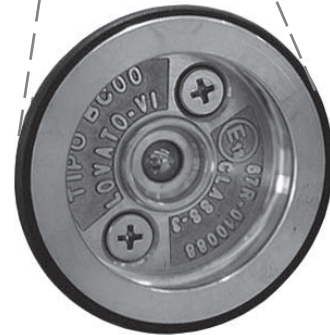
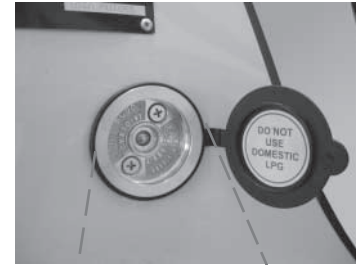

LPG Fuel Filling Cap

KNOW YOUR INDICA LPG

Running on LPG

RUNNING ON LPG :

A Fuel Selector Switch is provided on the dashboard. By toggling this switch, you can choose your fuel option for running. If LPG mode is selected, a green light indicating “LPG” illuminates on the instrument cluster. If Petrol mode is selected, the “LPG” light on instrument cluster turns OFF.

If petrol mode is selected, the engine starts and runs using petrol as fuel.

If LPG mode is selected, there are two stages of starting.

- The engine starts by using petrol when the engine is cold and automatically switches over to LPG once the engine warms up.
- After attaining the warm up temperature, the engine starts and runs by using LPG as fuel.

IMPORTANT

Ensure that your car has sufficient petrol in the tank as petrol is used for starting until the engine warms up.

IMPORTANT

Ensure that you run your car in petrol mode for atleast 30kms for every 300kms covered in LPG mode.



GAS Selector Switch

Petrol to LPG mode :

You can shift to LPG fuel mode by pressing the Fuel Selector Switch till the “LPG” light on the instrument cluster starts flashing. On successful transition to LPG mode, the green “LPG” light glows permanently indicating that the car is running using LPG as fuel

LPG to Petrol mode

Similarly you can switch from LPG to petrol mode by pressing the Fuel Selector Switch till the “LPG” light switches OFF. This indicates that the car is running using petrol as fuel.

NOTICE

1. In case of fuel mode switching from Petrol to LPG mode during normal running, initially the LPG LIGHT toggle indicating the transition and when the LPG LIGHT glows permanently, this indicates the completion of the transition to the required fuel mode.
2. Fast flashing of the LPG LIGHT indicates fault in the LPG system. Car will automatically switch to Petrol mode. Please get car checked/repared at the nearest Authorised TATA service center.
3. Very slow flashing of the LPG LIGHT indicates the empty tank / no LPG supply (loss of pressure). Get the LPG tank re-filled.

DO'S

- Always get the car repaired/serviced at the **Authorised TATA Service center** only.
- Never carry out any repair work on your own or from any other personnel other than from **Authorised TATA Service center**.
- Check LPG fuel system periodically for leakages
Even though the Safety Solenoid valve (on tank & pressure regulator) closes automatically when you switch off Ignition, it is recommended to close the manual service valves during any service/repair activity on the car.
- Ensure adequate ventilation around the car during repair works.
- Ensure the LPG in the pipe lines is consumed by running the engine with closed manual service valves before any repair work on the gas lines/joints.
- Remove the LPG tank during the welding/brazing work on the Car.
- Fast flashing of "LPG" light on the instrument cluster means fault in the LPG system, please get the car repaired at the nearest Authorised TATA Service center.
- Immediately repair/replace any damaged fuel or system component.

- Use the fire extinguishers provided with the car in case of unlikely event of fire. Two of these are provided, one near the driver seat and the other in the boot. Read instructions on Fire extinguisher to know how to use it.

DON'TS

- Over filling the LPG Tank can cause safety issues like gas leakage . Please DONOT over fill the tank beyond its capacity of 31 litres.
- Keep the car away from any Fire source.
- **Never use naked flame/fire to check gas leakages.**
- Never carry out any welding/brazing on the LPG tanks.
- Avoid direct contact with LPG as it may cause frost burns.
- **Wash instructions** - Do not direct high pressure washer fluid/water jets at electrical devices & their connectors during washing. This is to prevent malfunction / failure of electrical system due to water ingress.
- Do not tamper any electrical or mechanical settings.
- Do not scrap / gas cut the LPG cylinder as it contains pressurised gas which is flammable.
- Do not leave the LPG tank cover open.

For any clarifications please contact the **Authorised TATA Service center**

IN CASE OF GAS LEAKAGE :

- Do not panic.
- The ECU automatically switches-off the LPG supply from the tank.
- As a safety precaution, close the manual shut - off valves provided on the 'Multifunction valve' located on the LPG tank. Ensure that the tank cover is properly fitted.
- Roll down all the windows and keep the doors fully open.
- The ECU will automatically switch the fuel mode to Petrol.
- The ECU will not allow you to switch to LPG mode until the leakage is rectified.
- Contact the nearest Tata Authorised service station and get car repaired.

FIRE EXTINGUISHER :

Two fire extinguishers are provided on the car, one near driver seat and another in the luggage compartment.

Method of operation:

1. Check if the pressure gauge needle in green zone.
2. Hold upright and pull the pin.
3. Press the lever.
4. Direct discharge at base of flame with rapid sweeping motion.
5. Recharge the fire extinguisher after use.

Maintenance :

Check pressure on the gauge every week, needle should remain in green region. If it comes to red region, please send for recharging. **The Fire Extinguisher is to be refilled every three years even if it is not used.**



Fire extinguisher near Driver's Seat



Fire extinguisher behind Rear Seat

MANUAL SHUT OFF KNOB / LEVER

This knob is used to shut OFF LPG flow & is located on the Multifunction valve, on the Auto LPG Tank. This valve should always be in open position (as per figure), so that there is unrestricted flow of LPG to the engine. When the valve is in the closed position, LPG flow to the engine is stopped.

This Valve must be closed during any service/ repair activity on the car. Ensure that the tank's cover is tightened / closed properly.

LEVEL INDICATOR

A multivalve is mounted on the LPG tank which also has a gauge that shows LPG level in the tank. LPG level can also be known by fuel gauge on instrument cluster based on the fuel selector switch position (Gas mode or Petrol mode).

NOTE : The LED indication is an additional indication of LPG quantity in tank.

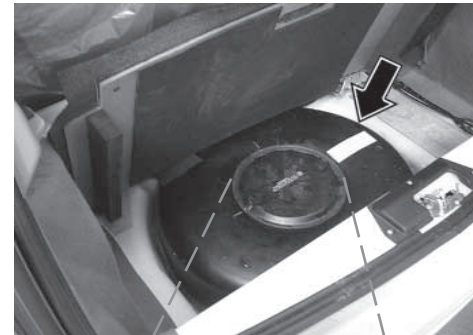

LPG Tank

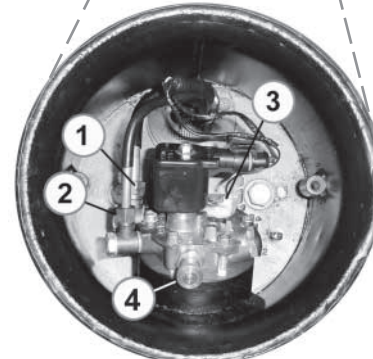

1. Inlet
2. Outlet
3. Level Indicator (Dial type)
4. Manual Shut Off Valve

KNOW YOUR INDICA LPG

Your car's LPG tank needs to be recertified every five years as per CMVR (AIS 24, 25 and 26)

Please ensure that it is done by a TATA Authorised Service Outlet and the new date is engraved on the plate.



Compliance to Motor Vehicle rules

TATA

VEHICLE CHASSIS NO. _____

AUTO LPG TANK ID. NO. _____

DATE OF INSTALLATION _____

WATER CAPACITY (LITRES) _____

DATE OF LAST RETEST _____

1st RECERTIFICATION * _____

2nd RECERTIFICATION * _____

EXPIRY DATE OF TANK _____

* THIS INFORMATION TO BE ENGRAVED IN THE FIELD
THIS INSTALLATION COMPLIES WITH SAFETY
REQUIREMENTS OF AIS 026

INSTALLED BY _____

KNOW YOUR INDICA LPG

Location of LPG system components

- 01. LPG FILLER VALVE
- 02. VENT TUBE
- 03. COUPLING JOINT
- 04. HIGH PRESSURE TUBE (8mm)
- 05. LPG TOROIDAL TANK
- 06. MULTIFUNCTION VALVE
- 07. UNDERBODY JOINT
- 08. HIGH PRESSURE TUBE (6mm)
- 09. FILTER - LPG
- 10. LOW PRESSURE LINE
- 11. PRESSURE REGULATOR
- 12. HEAT SHIELD.
- 13. INJECTOR
- 14. INJECTOR LINES
- 15. FUEL RAIL (LPG)

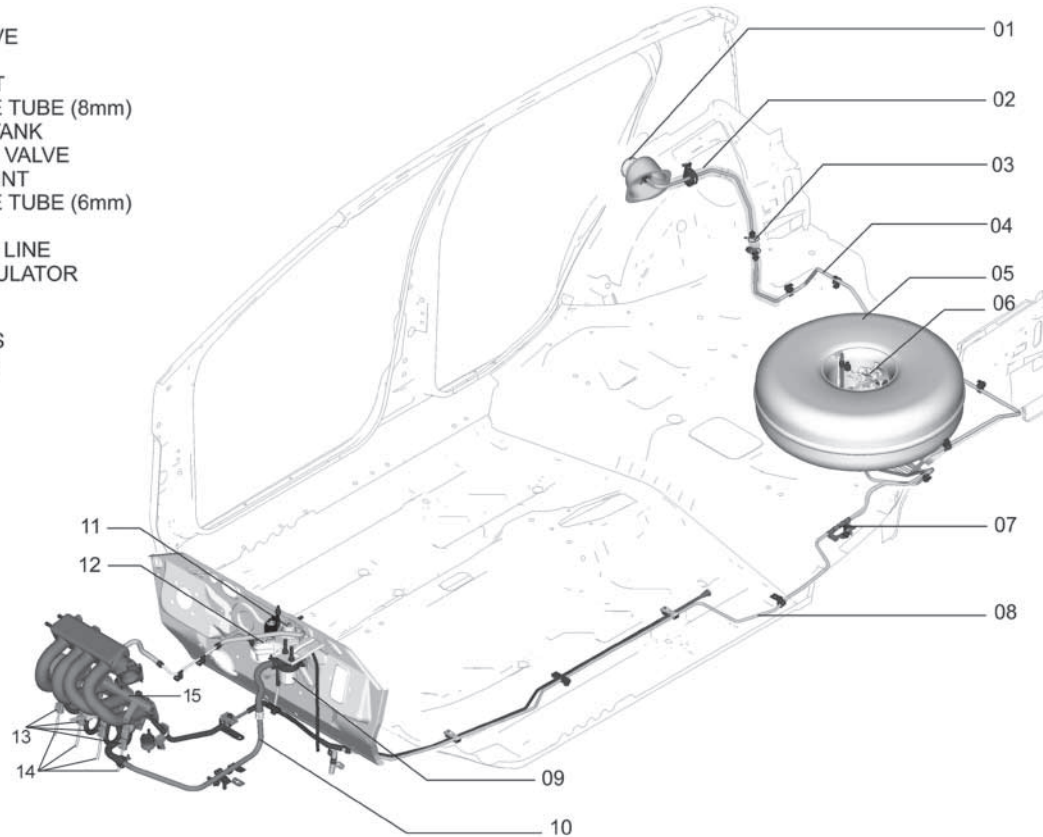



BEFORE DRIVING

- **CONTROLS**
- **INSTRUMENT PANEL**
- **HEATING, VENTILATION & AIR CONDITIONING**
- **INTERIORS & ACCESSORIES**
 - Rear View Mirrors
 - Sunvisors
 - Glove Box
 - Window Winding
 - Power Windows
 - Tray Cover with Coin Holder
 - Plug Socket
 - Rear Ashtray
 - Digital Clock
 - Roof Mounted Interior Lights
 - Front Seat & Seat Adjustments

- Head Rest
- Rear Seat
- Seat Belt Adjustment
- Tailgate Opening
- Fuel Flap Opening
- Music System
- Electrical Accessories
- Fitment
- Load Area Lamp
- Front Fog Lamps
- Head Lamp Leveling Switch

DRIVING CONTROLS

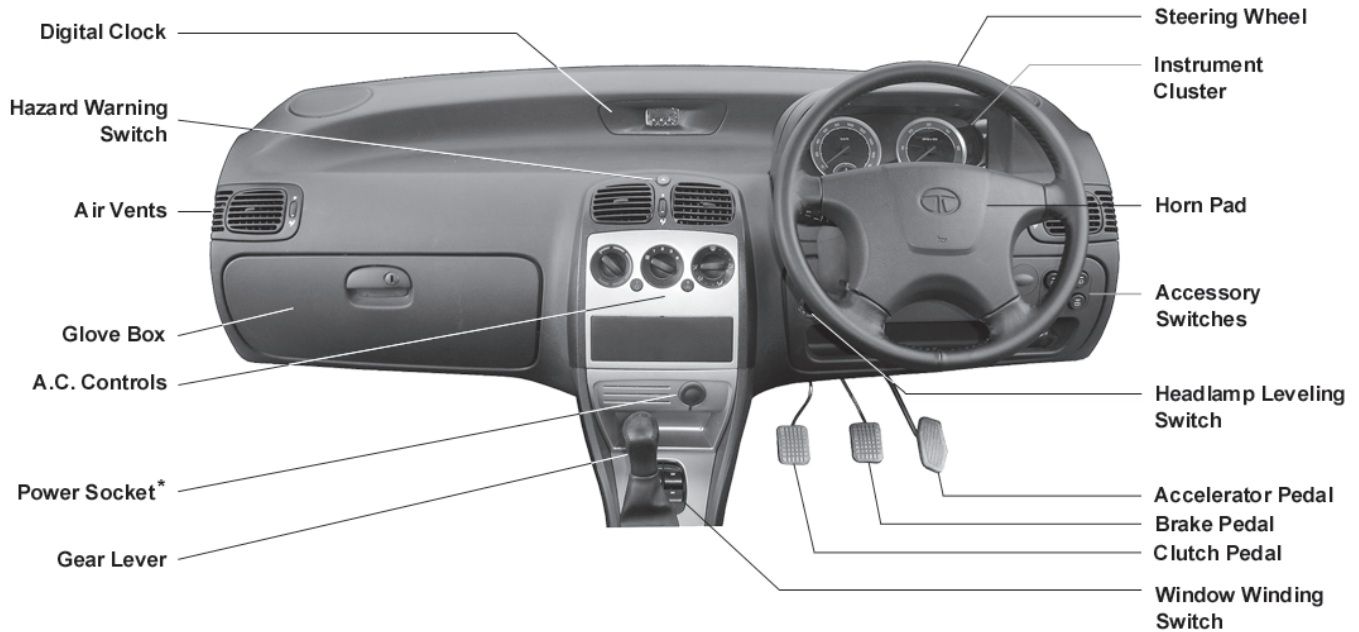

(* In some versions, the power socket is located on the floor console behind gear shift lever.)

BEFORE DRIVING

Controls

Keys :

Your car comes with two identical keys.

With this key, you can operate

1. Door Locks
2. Steering Lock cum ignition switch
3. Tail gate Lock
4. Glove box

It is advisable to keep one of the keys in a safe place for use in case of an emergency.



Do not use a locally made key, but obtain a duplicate through your Tata Motors dealer.
Do not leave the key inside the car.

Door Locks :

The front doors can be locked and unlocked from outside with the key or from inside using the door lock lever. In your car, the driver's door & co-driver's door have separate locking facilities. To lock from inside turn the lever towards the inner hinged handle.

Where the central locking system is provided, if you lock/unlock the driver door with the key, the remaining three doors get locked/unlocked at a time. The tail gate door is not a part of the central locking provision.

To open the door from outside use the swing handle. After unlocking the door with the key, pull the swing handle upward. The swing handles are provided on each door.

To open the door from inside pull the hinged handle outward.

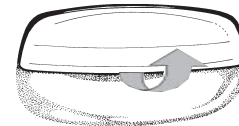
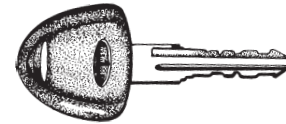

To open

Outside swing handle

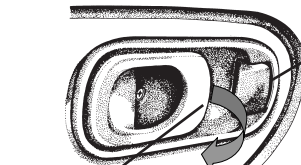
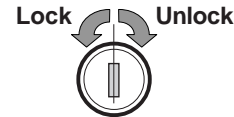

Locking /
Unlocking
lever

Hinged handle

Inside door handle

IN CASE OF EMERGENCY

- 1) The electrically operated devices (like central locking, power window) may malfunction in the event of flood/fire, due to temporary or permanent damage to the device. Exercise appropriate precautions for safety of yourself and other occupants.
- 2) If the central locking system malfunctions and is unable to unlock doors electrically, the door can still be opened by manually unlocking knob '1' and opening the door using lever '2'. The mechanical system overrides the electrically operated system.

Childproof Lock :

Both the rear doors of the car are provided with childproof locks. Push the lock lever located on the vertical face near the rear lock downward before closing the door. The door which has been locked can no longer be opened from inside.

When child lock on rear door is 'LOCKED', the door can only be opened from outside. Use front doors to exit or take help of front occupants

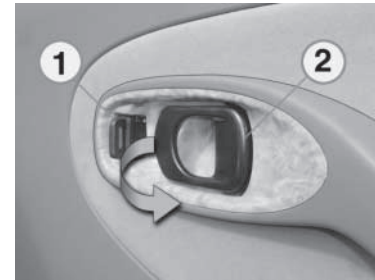

Deactivate the childproof lock when not required.

Steering lock cum ignition switch :

The steering column lock cum ignition switch has the following four positions and is operated with the key.

1. **LOCK POSITION** - The key can be inserted or taken out only in this position. When the key is removed from the switch, the steering is locked. To unlock the steering, insert the key and also turn it to the 'OFF' (Steering unlock) position.
2. **'OFF' POSITION** - In this position, the steering lock opens and the music system is powered.



Ignition Switch

3. **'IGN' POSITION** - This is for switching 'ON' the power supply to the following items :

- Blower & A/C (if fitted)
- Engine cooling fan
- Horn
- Power Socket
- Power window (if provided)
- Head Lamp Leveling Switch
- Head lamps
- Front fog lamps (if provided)
- Load Area Lamp
- Music system (if provided)
- Digital clock
- Engine ignition & fuel supply
- Turn signal lamps
- Wash and wiper system
- Reverse light
- Instruments and gauges and tell tale warning lamps
- Audio warning unit
- Fog Lamps

4. **'START' POSITION (Spring return to 'IGN' position)** - In this position, which is momentary, the switch cranks the engine. When the switch is in this position momentarily, the devices listed under "Accessories supply" above, are switched 'OFF'.

The following items are operated/powered without the key in the ignition switch :

Hazard warning system, Stop lamps, Position lamps, Registration plate lamps, Illumination of A.C. control panel, Odometer display (LCD) of Instrument Panel, Roof lamp, Reading lamps, Engine lamp, Load Area Lamp, Central door locking, Audio warning unit, Memory of digital clock and Music System, Rear Windshield Demister.

The switch symbol lamps may come 'ON' without the key in the 'IGN' position on ignition switch.

Note : When the key is returned from 'OFF' position to LOCK position, the music system continues to be powered until the key is removed from the switch. This also helps to remind the driver if the key is inadvertently left in the vehicle when alighting from the vehicle, where this is provided.



- I) Do not remove the key, while the car is in motion, as the steering will get locked and the car cannot be steered.
- II) While turning the key from 'LOCK' position to 'OFF' position slightly rotate steering wheel to relieve pressure on steering spindle for easy operation of the key. Also ensure the key is inserted fully before turning the key.

Combi-switch

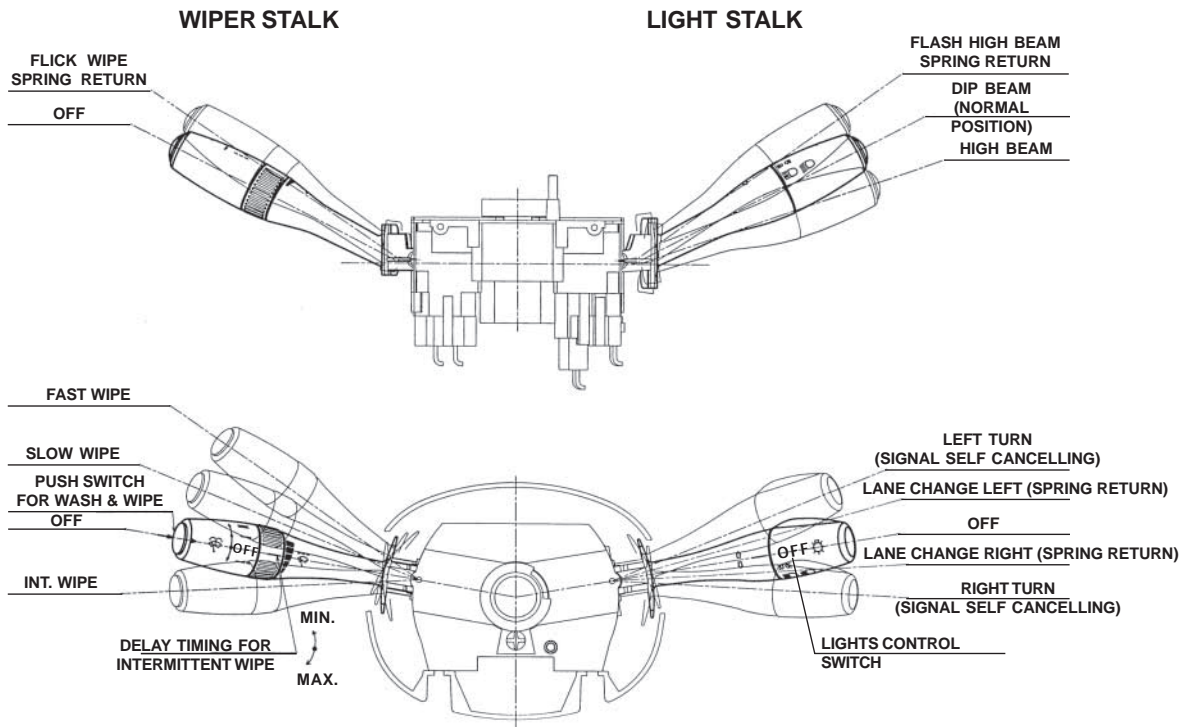

WIPER CONTROL COMBI-SWITCH LEVER - LEFT

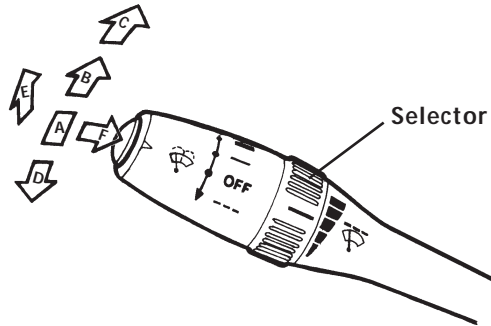

Wiper Control Combi-switch Lever - Left

- A. Wiper 'OFF' position
- B. Slow Wipe
- C. Fast Wipe
- D. Intermittent wipe *
- E. Pull up for windshield wipe
(Flick Wipe Spring Return)
- F. Press side knob for wash

* Rotate selector to set delay timing for intermittent wipe

LIGHTS CONTROL COMBI-SWITCH LEVER - RIGHT

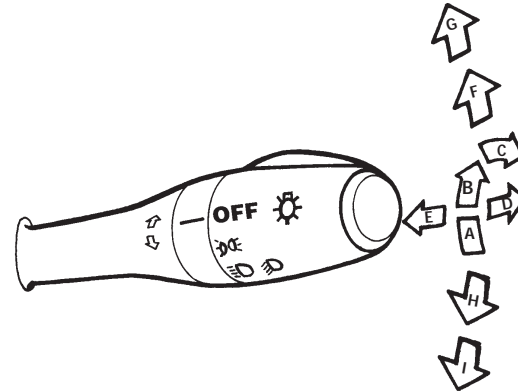

Lights Control Combi-switch Lever - Right

- A. Head lamp 'OFF' position
- B. Position lamp 'ON'
- C. Position lamp & head lamp 'ON'
- D. Push down the lever for high beam
- E. Pull up the lever (spring return) for high beam flash
- F. Lane change left (spring return)
- G. Side Indicator - LH
- H. Lane change right (spring return)
- I. Side Indicator - RH

BEFORE DRIVING

Controls

Fog lamps : (if fitted)

Front and Rear fog lamps can be switched ON/OFF by operating the switch on the Combi-Switch.

Front fog lamp : Rotate the switch clockwise to switch 'ON' the front fog lamp. Front fog lamps are operative only when the position lamps are switched 'ON'. Rotate the switch to same direction to switch 'OFF' the front fog lamp.

The indicator on the instrument cluster comes 'ON' when the front fog lamps are switched 'ON'.

Rear fog lamp : Rotate the switch anticlockwise to switch 'ON' the rear fog lamp. Rear fog lamps are operative only when the head lights are switched 'ON' or front fog lamps are switched 'ON'. Rotate the switch to same direction to switch 'OFF' the rear fog lamp.

The indicator on the instrument cluster comes 'ON' when the rear fog lamps are switched 'ON'.

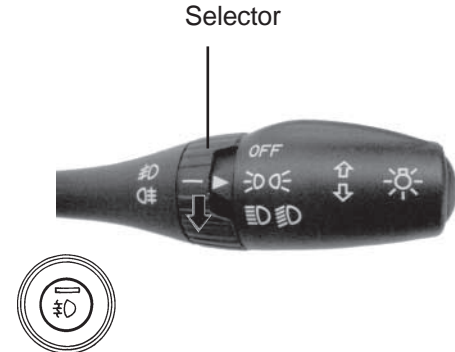
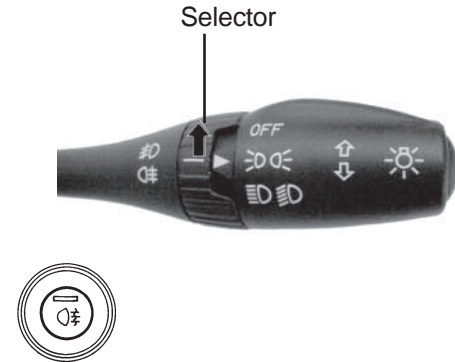

Accessory Switches : (if installed)

Accessory switches have been provided on the dash board near the steering column on the right hand side.

1. Rear windshield demister (unlatched switch)



The switch is pushed and released to switch 'ON' and the knob returns to the normal position. The function indicator lights up in amber indicating that the demister heater is 'ON'. The function is controlled through a timer and operates for 15 minutes (approximately) and goes 'OFF' automatically at the end of the duration. The heater can be switched 'OFF' anytime by once again pushing and releasing the switch knob.

Note : Switching 'ON' and 'OFF' can be done only with key in 'IGN' position. The demister heater remains 'ON' even after removal of ignition switch key and goes 'OFF' at the end of 15 minutes period, In case you have missed to switch it 'OFF'.

2. Rear windshield wiper (latched switch)

Push to switch 'ON' - Push to switch 'OFF'
The function indicator on the knob lights up in green when the wiper function is 'ON'.



3. Rear windshield wash & wipe (unlatched switch):

Push and hold the switch knob for the operation of the wash function on the rear windshield glass for rear visibility through glass. The function indicator lights up in green when wash function in 'ON'. Along with the wash fluid getting sprayed, the wiper also operate with a delay to wipe the glass surface, through timer control unit.



Gearshift lever & Shifting pattern :

The gearshift lever is mounted on the central console between the two front seats. The gearshift pattern is shown on the gear lever knob.



The reverse gear should be engaged only when the car is stationary. Wait for 5 seconds after declutching to ensure smooth engagement of the reverse gear.

Parking brake :

A mechanical parking brake acting only on the rear wheels is provided on your car. The parking brake lever is located behind the gearshift lever. To apply the parking brake, pull the lever up fully. The indicator light (ⓘ) (Ⓟ) on the instrument panel will come 'ON'. To release it, **pull the lever up slightly**, press the release button and push the lever down.

The parking brake indicator (ⓘ) (Ⓟ) on the instrument panel will go 'OFF' when the parking brake lever is fully released.

When parking on level ground, place the gear lever in the 'Neutral' position. When parking on a downhill gradient, place the gear lever in 'Reverse' position. When parking on uphill gradient, place the gear lever in the '1st' position



Apply the parking brake properly before leaving the car & release it before moving. Use the parking brake for holding the car on a gradient.

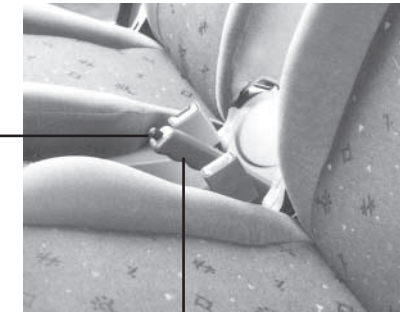
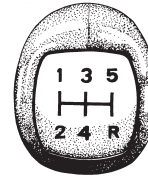

Release Button

Parking Brake Lever

INSTRUMENT PANEL

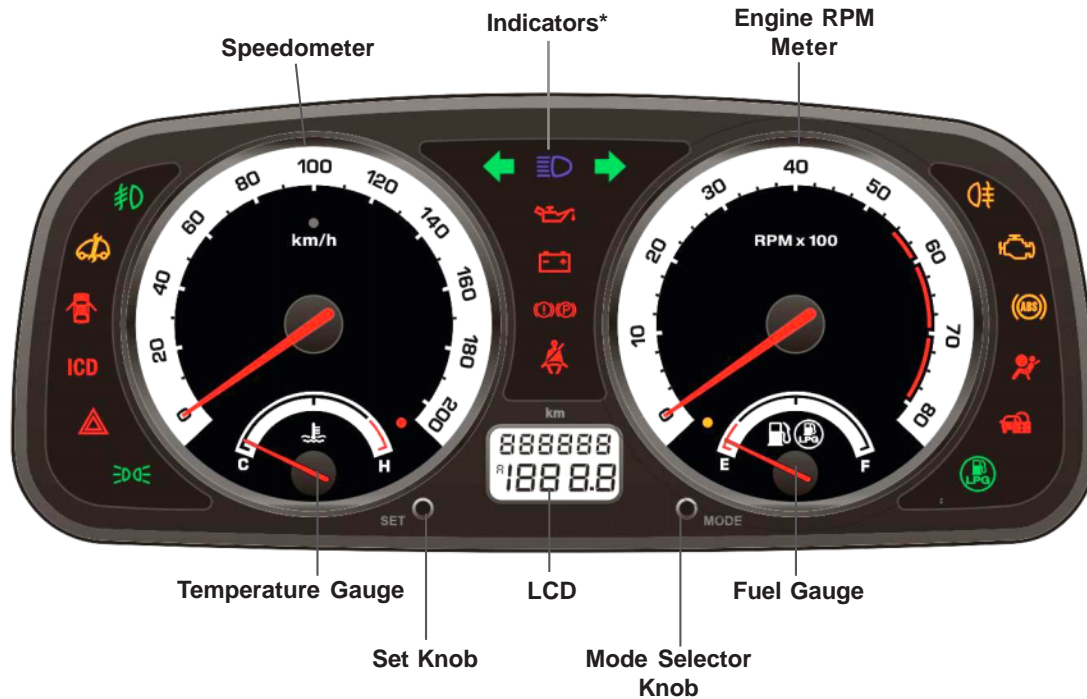

Turn Signal and Hazard Warning

I) Turn Signal :

Turn signal lamps can be operated only when the ignition supply is 'ON' by using the turn indicator switch on the combiswitch.

The direction indicator ◀ (LHS) and ▶ (RHS) on the instrument cluster flashes along with external indicator lights as selected.



II) Hazard Warning :

This can be operated without ignition 'ON'. Press the hazard warning switch (red knob) on the centre of the dash board, all side indicator lights and indicator ▲, LHS and RHS turn indicators on the instrument cluster will flash simultaneously to warn the other road users about any hazardous condition of the car. Depress the knob again to switch 'OFF' the hazard function.



Hazard Warning Switch

Note : If light does not blink or blinks rapidly, it is an indication of fault in the blinker electrical system or the indicator bulb at front or rear has fused. Get it rectified immediately.

Parking Brake Indicator cum Low Brake Fluid Warning Light

When the ignition key is turned to the 'IGN' position, the symbols light up for the following :

- i) when the parking brake is applied, and/or
- ii) when the brake fluid level in the container is low.

Else the indication goes 'OFF' after few seconds.

If the lamp glows while engine is running, then check the parking brake or brake fluid oil level.



Do not drive the car if this indicator remains 'ON'. Get the problem attended to immediately at an Authorised Service outlet.

High Beam Indicator:

Symbol lights up when the headlamp high beam is ON.

Malfunction Indicator: (BS - IV)\Check Engine Indicator (BS - III)

1. This lamp indicates the engine condition. When a malfunction occurs in Engine or Engine Management System (EMS), this lamp will glow when the engine is running to indicate the fault.



NOTE

When the IGN is turned 'ON' this lamp will glow for a few seconds and go off, this is normal and indicates that the lamp is OK.

Position Lamp Indicator :

Symbol lights up when the position lamps are switched 'ON'. Illumination lamps for AC, HVAC or ventilation panel and switch illumination lamps comes 'ON', when the position lamps are 'ON'. Position lamps can be used as parking lamps. Instrument cluster illumination turns 'ON' with key in 'IGN' position and position lamps 'ON'.

Note : Position lamps also remain 'ON' while head lamps are 'ON' and in this condition instrument cluster illumination lamp will not be 'ON'.

Low Oil Pressure Indicator :

When the ignition key is turned to the 'IGN' position, symbol lights up and goes off as soon as the required engine oil pressure is developed after starting the engine.

 If the low oil pressure indicator does not glow or remains 'ON' with the 'IGN' on and engine is running, it indicates a fault in the electrical circuit/lubrication system. Check & get the problem attended to at an Authorised Service outlet.



BEFORE DRIVING

Indicators

Battery Charging Indicator :

Symbol lights up when the 'IGN' is turned 'ON' and should go 'OFF' after the engine starts.



If it remains 'ON' while the engine is running, it indicates that the battery is not being charged. Switch off all unnecessary electrical equipment and get the problem attended to at an Authorised Service outlet.

Front Fog Lamp Indicator (if provided) :

This symbol lights up when the front fog lamps are switched 'ON'



Rear Fog Lamp Indicator (if provided) :

This symbol lights up when the rear fog lamps are switched 'ON'



Immobilizer Warning (if fitted) :

This system disables the starter motor circuit ignition supply and fuel cut-off solenoid supply. The vehicle can be unlocked only pressing the UNLOCK button of the corresponding vehicle remote.

It will blink when vehicle is immobilized condition. Unlock with remote and start vehicle.



BEFORE DRIVING

Speedometer, Main Odometer and Tripmeter (on LCD) :

The speedometer indicates the car speed in km/hr. The odometer records the total distance the car has been driven. The tripmeter can be used to measure the distance travelled on each trip or between fuel fillings.



Keep track of the odometer reading & follow the maintenance schedule regularly for meeting service requirements.

Odometer, Tripmeter and Illumination intensity control on instrument panel (LCD) :

The instrument panel has an LCD to display the following :

Main Odometer (Non- resettable) - Counts upto 999999 kms

Tripmeter A (Resettable) - Counts upto 1999.9 kms

Tripmeter B (Resettable) - Counts upto 999.9 kms

Intensity level of instrument panel illumination - selection among preset levels.

LCD has two line display. The first line displays the Odometer count. The second line displays either of Tripmeter A, Tripmeter B, Intensity level of panel illumination.

The selection and control of functions are done through 'MODE' and 'SET' push buttons (knobs) provided on either side of the LCD.

The 'MODE' knob is used to select one of Tripmeter A, Tripmeter B or Intensity level of panel illumination. Switching among the above three functions can be done by pressing the knob.

Over speed warning indicator



Speedometer



Display for Trip - A



Display for Trip - B

BEFORE DRIVING

Gauges

The 'SET' knob is used to control the chosen function. Pressing the knob for a few seconds resets the chosen tripmeter and varies the intensity level of instrument panel illumination.

The panel illumination intensity varies among preset levels as follows :

= Min
= = = = Max

This display returns to Trip A after a few seconds of intensity level selection, if left in this mode.

NOTICE

Main odometer and tripmeter A indication will remain on display even if the ignition key is removed.

Reduced contrast in display may occur at low and high temperature.

Over speed warning indicator (if provided) :

When the vehicle speed reaches more than 120 kmph, over speed warning indicator will come 'ON'.



Intensity Level Indicator

Over Speed Warning Indicator

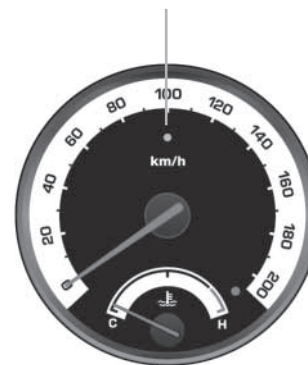

BEFORE DRIVING

Gauges

RPM meter :

The meter indicates engine speed in revolutions per minute (rpm)
Change gears at appropriate engine rpm and car speed to get optimum fuel economy.

The permitted engine rpm upper limit is the start of Red Zone on the dial.

If RPM meter does not indicate during initial cold starting, gently raise the engine rpm till the battery charge lamp goes 'OFF'.

Temperature gauge :

The gauges indicates the temperature level of the engine coolant. The red zone at 'H' indicates temperatures higher than normal. A visual warning indication (Red coloured) comes 'ON' indicating that when the coolant temperature is higher than normal.

Avoid driving, when the pointer is in the red zone. It indicates engine overheating, which may be due to insufficient coolant in the radiator or due to any other defect. Take the car to the nearest Authorised Service outlet for necessary attention.



Never remove the cap from the coolant reservoir when the engine is hot. Do not restart the engine until the problem has been duly attended.

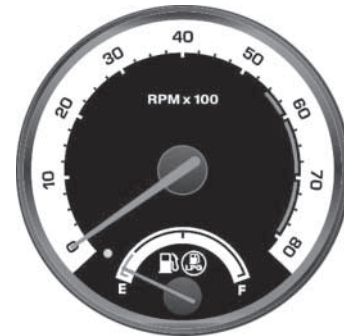

RPM Meter



Temperature Gauge High Temperature Warning

BEFORE DRIVING

Audio Warning

Fuel Gauge :

The fuel gauge indicates the approximate fuel level in the tank. When the engine is in Petrol mode the petrol LED glows and the gauge shows the level of petrol, and likewise when it is LPG mode the LPG LED glows and shows the LPG level. When the needle touches the red band (indicating reserve capacity has been reached.), a visual warning indication (Amber coloured) comes 'ON' indicating the fuel level is low. Refill the fuel tank at the earliest.

Audio Warning Unit

Seat Belt Reminder (Beeper) : (If installed)

When the key is in the 'IGN' position and the driver's seat belt has not been fastened, an audio warning comes 'ON'. Please fasten the seat belt. The warning goes 'OFF' automatically after a few seconds, even if the seat belt is not fastened.

'Key in' Warning Beeper : (if installed)

When the ignition is turned to 'OFF' position and the key is not removed from the switch, an audio beep comes on if driver door is open. The beeper will go 'OFF' after a few seconds automatically if warning is ignored or if the key is removed/door is closed.

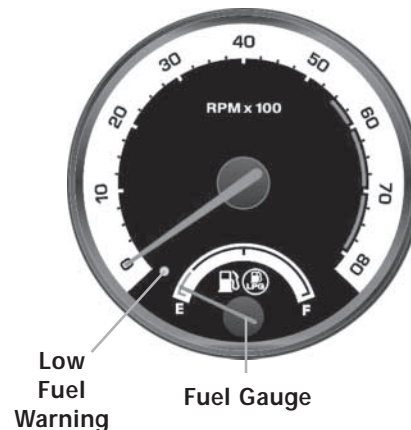

BEFORE DRIVING

Lamps 'ON' Reminder (if installed)

An audio warning (beeper) is provided to inform the driver that the headlamps/position lamps are left 'ON'. This comes 'ON' when the driver removes the key and opens the door. Switch 'OFF' the lamps, before leaving the car. However the lamps can be kept 'ON' ignoring the warning, if desired.

Tail Lamp : The tail lamp assembly incorporates the following-

1. Stop cum position lamp
2. Turn Indicator
3. Reverse Lamp
4. Fog lamp (provided in Deluxe version only)
5. Reflex reflector

Registration Plate Lamps :

Two concealed lamps are provided for illumination of the rear registration number plate.

High Mounted Stop Lamp :

High mounted stop lamp is provided at the rear of vehicle and it glows whenever the service brake is applied.

Audio Warning / Tail Lamps

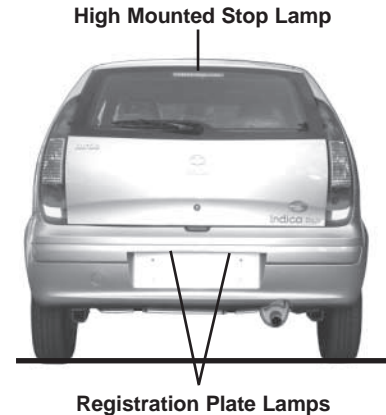
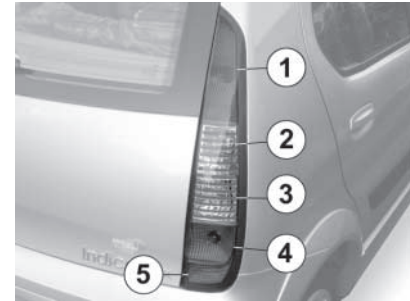

Air Flow Pattern

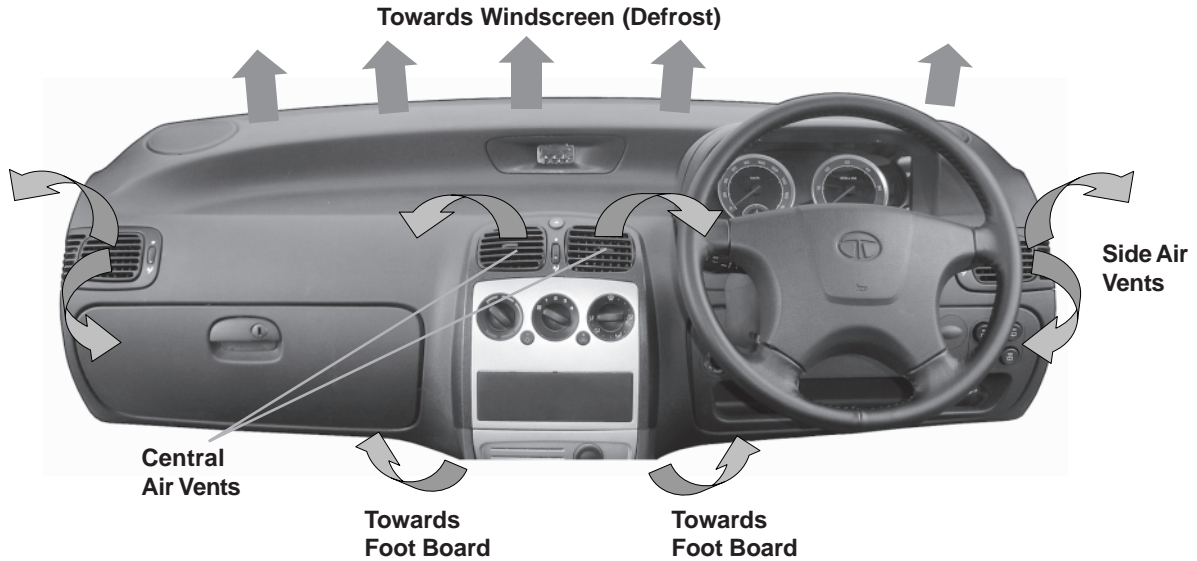

BEFORE DRIVING

Heating, Ventilation & Air Conditioning

HEATING, VENTILATION & AIR CONDITIONING

(if installed)

A. Temperature Control Knob :

The air temperature in the car can be controlled by operating the temperature control knob **(A)** at the left hand side of the control panel. The temperature can be increased by rotating the knob towards the red segment and decreased by rotating it towards the blue segment.

B. Blower Speed Regulation Knob :

The ventilation system has a three/four speed blower. The blower speeds can be regulated to any one of the following speeds by operating the knob **(B)** at the centre of the control panel.

LOW • MEDIUM • HIGH • VERY HIGH

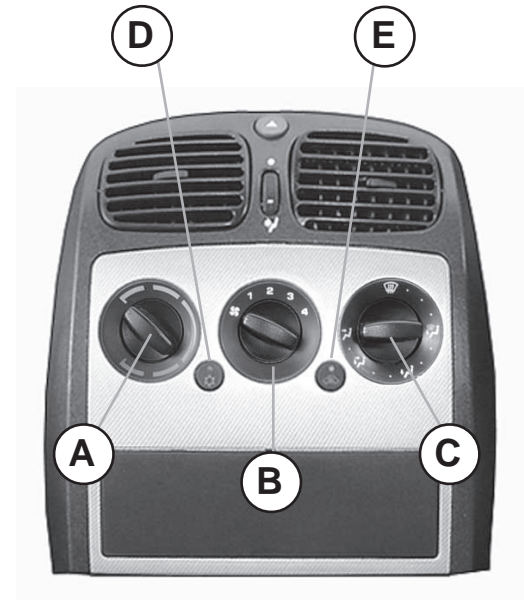

HVAC CONTROLS

BEFORE DRIVING

Heating, Ventilation & Air Conditioning

C. Air Direction Control Knob :

The air flow can be changed by turning the switch (C) to the desired direction.

➔  Towards face

➔  Towards face and feet

↓  Towards feet

 Towards feet and windshield
(Recommended for clearing fogging on windshield)

 Air demist / defrost windshield
(Recommended for clearing heavy fog and snow)

D. A.C. ON/OFF Switch :

The A.C. can be switched 'ON' by pressing the switch (D) on the A.C. control panel provided the blower is 'ON' and the engine is running. The indicator lamp will show that the A.C. is 'ON'.

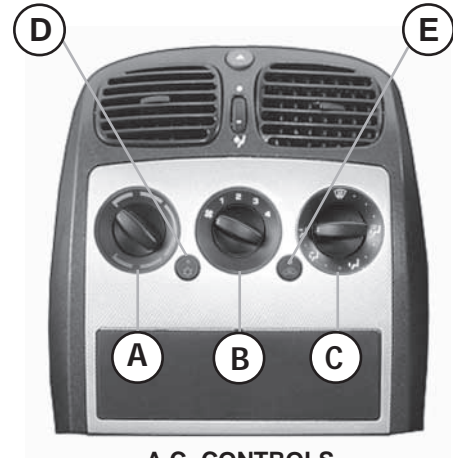

A.C. CONTROLS

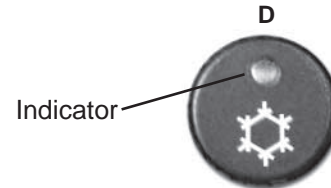

A.C. ON / OFF Switch

BEFORE DRIVING

Heating, Ventilation & Air Conditioning

E. Air Circulation Switch :

- In HVAC version to put air circulation mode in recirculation, press switch 'E'. The indicator lamp will show air circulation is in recirculation.
To put vehicle in Fresh mode release switch 'E'. Indicator lamp will be 'OFF'.
- In A.C. version, air circulation mode can be selected by rotating knob 'E'.

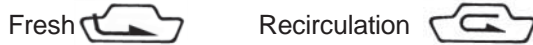

- In recirculation mode, air inside the vehicle is circulated again and again. In Fresh mode, air is taken from atmosphere and circulated in the vehicle.

Recirculation mode can be used

- While driving in dusty condition
- To avoid traffic pollution
- To get quick cooling/heating as required.

Whenever discomfort is felt switch air circulation mode to fresh.

Notice : The A.C. can be switched 'ON' only if the blower is 'ON' and engine is running. When A.C. is switched 'ON' engine idling RPM increases marginally, to adjust to the A.C. compressor load. When desired temperature is achieved A.C. trips 'OFF' automatically.

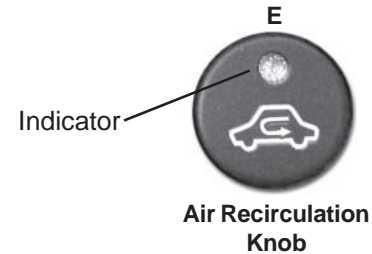

Notice : The A.C. compressor gets switched 'OFF' automatically when engine gets overheated. The A.C. is automatically switched 'ON' when the engine cools down.

Normal Cooling :

A.C. - ON

Knob 'B' - Desired speed position

Knob 'C' - Towards face 

Switch 'E' - Suitably as explained

Quick Cooling :

If your car is left in the sun with window closed inside the temperature inside the car increases.

BEFORE DRIVING

To achieve quick cooling effect, open the windows briefly while you operate the air conditioner, with air circulation switch is in Fresh mode, fan at higher speed and air direction towards 'FACE'. All vents to be opened completely.

Once temperature inside has come down sufficiently, close the windows and change air circulation suitably to fresh/recirculation.

Demisting :

In rainy season or in areas of high humidity, mist formation inside windshield glass is observed. To clear mist dehumidified air is passed on the windshield glass.

The position of control knobs should be adjusted as follows:

A.C. - ON

Knob 'B' - Desired speed position

Knob 'C' - Towards windshield 

Knob 'A' (for vehicles fitted with HVAC) - at suitable temperature

Air circulation - at suitable position

Notice : When mist gets cleared switch the knob "C" position to Face mode.

In high humidity areas, if cold air continues to flow over windshield, it may cause sudden fogging on outside surface of windshield.

Heating, Ventilation & Air Conditioning

Defrosting :

(For vehicles fitted with HVAC unit)

In low temperature areas, to clear frost formation outside the windshield glass, this setting is used.

First start the engine and accelerate to warm up.

Knob 'A' - Maximum hot position

Knob 'B' - Very High

Knob 'C' - Towards windshield 

Switch 'E' - Fresh air mode condition

Once the windscreen has become clear, move the fan switch to desired speed.

Notice : Electric heater coil is provided for demisting of tail gate glass for deluxe versions.

Normal Heating :

(For vehicles fitted with HVAC)

Knob 'A' - Suitable temperature position

Knob 'B' - Suitable blower speed

Knob 'C' - Towards face & feet 

A.C. - OFF

Air Circulation- Fresh switch

BEFORE DRIVING

Heating, Ventilation & Air Conditioning

Quick Heating :

All settings as explained before except air circulation switch to recirculation.

Once vehicle is heated, switch back to fresh mode.

Ventilator :

The air flow can be adjusted continuously with the rotary control knob at the vents on the dash board. The air vents can be adjusted upward and downward. This is common for HVAC, AC and ventilation.

Notice : Refrigerant charged in the air conditioning circuit has been identified on the label over front body member. Use only refrigerant as given in the label for topping up or recharge, i.e. do not charge R12 (CFC) in the vehicle earlier charged with R134a (Non CFC) or vice versa.

Notice : Fresh air is taken from the grill opening provided at base of windshield glass outside the vehicle. Keep these openings clear and free from fallen leaves etc.

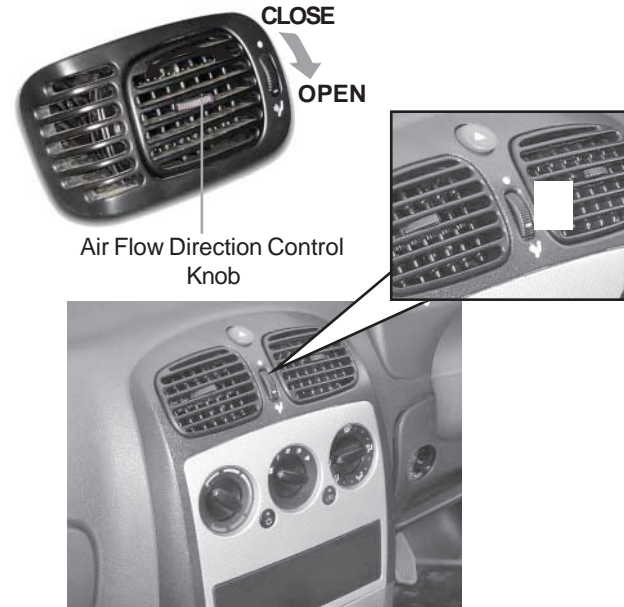

BEFORE DRIVING

Interiors and Accessories

REAR VIEW MIRRORS

Door mirrors : Driver side only (alternate) Both sides (if fitted)

The rear view mirror is fitted on the door from the outside and can be adjusted by the lever provided inside the door. In some versions the mirrors are provided on both the doors.

Inner Rear View Mirror :

Plain mirror (Alternate)

Antiglare mirror (if fitted)

If an antiglare mirror has been fitted inside the cab. Provision has been made for two positions :

1. Normal position
2. Antiglare position

Use antiglare position only when necessary, as it reduces rear view clarity.

Normal Mirror (if fitted)

In some versions, a normal mirror has been fitted inside the cab.

Sunvisors :

Two adjustable sunvisors are provided inside the cab above the windshield to prevent sun glare.

Lower the sunvisors to protect the eyes from bright sunlight. The sunvisor also moves sideways towards the door.

A vanity mirror has been provided on the back of the co-driver's sunvisor.

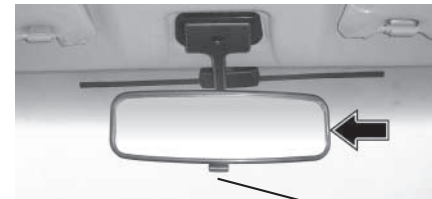
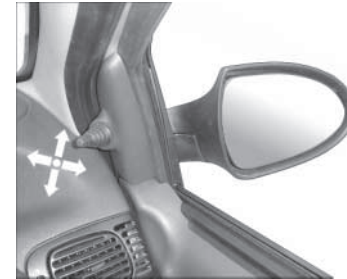

ANTIGLARE MIRROR
(Only on deluxe version)

**Operating
Knob**

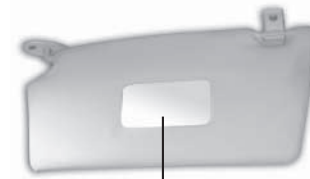

Vanity Mirror

BEFORE DRIVING



When not in use keep the sunvisors in their stowed position otherwise they may block the driver's vision.

Glove Box :

The glove box is located on the dash board in front of the co-driver's seat. The glove box can be locked with the ignition key.

Cup holders are provided on the inner face of glove box flap.



Do not use the cup holder while the car is in motion.

Window Winding :

Manually Operated Window Winding :

Window winding in the standard version is manually operated. Rotate the handle on the door pad to raise or lower the window glass.

Interiors and Accessories

Cup Holders

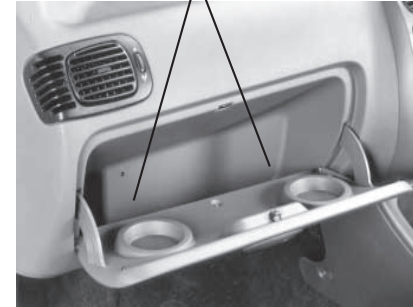

Glove Box



Window Winding Lever

BEFORE DRIVING

Power Windows : (if installed)

Four separate knobs are provided on the switch to operate the four door window glasses individually and electrically.

To open the door window glass, push the respective knob down.

To close the door window glass, pull the respective knob up.

In the locked position, the rear window switches on rear doors become inoperative. However the rear windows can be operated by the switches on the floor console. Illumination on rear window switches goes 'OFF' in locked position. Press down the lock button to unlock.

Individual window winding switches have been provided only on the rear doors.



While raising the glass take care to avoid fingers/hands getting trapped between the glass and the frame.

Interiors and Accessories

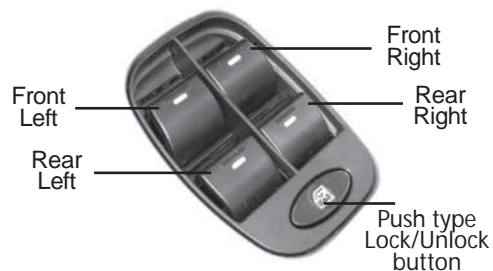

**Window Winding Switch
On floor Console**



Window Winding Switch On Rear Door

BEFORE DRIVING

Interiors and Accessories

Power Socket : (if provided)

Power socket is provided on the floor console behind the gear shift lever (for standard versions). A Plug socket is provided on central fascia (for Deluxe versions). This can be used for connecting loads upto 10A maximum like the mobile charger, cigarette lighter etc. To use this socket, remove the cap first.



Always keep this socket covered with the cap when not in use.



Power Socket (Deluxe version)

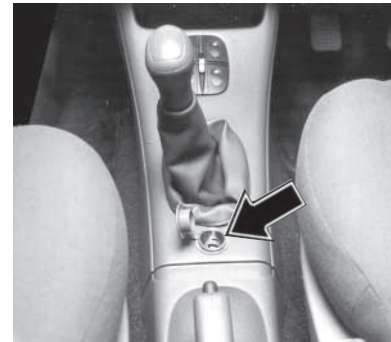

Power Socket (Standard version)

BEFORE DRIVING

Interiors and Accessories

Rear Ash Tray : (if fitted)

Ash trays are provided on both rear doors for the occupants at the rear.

To open the rear ash tray press the lid, it will rotate outward.

To remove the ashtray open fully and press down to disengage the top pivot pin.

To refit the ashtray, locate the bottom pivot pin and push the top pivot pin in to place.



Do not forget to extinguish the cigarette butts, before putting them in the ash tray.

Do not put paper or other flammable material in the ash trays.

Digital Clock :

A digital clock is provided in the middle of the dash board. It displays the time when the steering lock cum ignition switch is in 'IGN' position.

Three push knobs 'H', 'M' and 'Z' are provided for setting the time and for resetting the display to zero - 'H' for hours setting, 'M' for minute setting and 'Z' for setting minutes to zero.

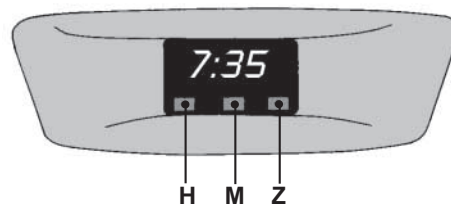

BEFORE DRIVING

Interiors and Accessories

Roof Mounted Interior Light & Reading Lamps :

Interior roof light and reading lamps with inbuilt switches are provided on the roof near the rear view mirror.

The central rectangular toggle switch (1) has three positions :

- When the central rectangular toggle switch is in the MIDDLE position, the light will come 'ON' only when any of the doors are opened.
- When this switch is in the RIGHT position, the light will remain 'OFF' in all conditions.
- When this switch is in the LEFT position, the light will be continuously 'ON' irrespective of whether any of the doors are open.

Two more triangular push type switches (2) are provided to operate the individual reading lamps.

Reading Lamps

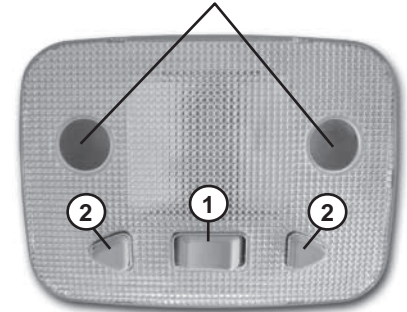

Roof Mounted Interior Lamp and Reading Lamps

BEFORE DRIVING

Interiors and Accessories

Front Seats and Seat Adjustments :

Front Seats : Both the driver and co-driver seats are of bucket type to provide maximum riding comfort.

Moving the seats forward and backward :

To adjust the seat position, lift the lever under the seat cushion front, then move the seat to the desired position and release the lever.

Make sure the seat is locked in position.

Adjusting the angle of the seat back :

To adjust the angle of the seat back, a lever has been provided on the sides of the front seats. By lifting the lever, you can adjust the angle of the backrest.



Do not adjust the seat when the car is in motion.

Always adjust the seat back to an upright position and sit well back in the seat.

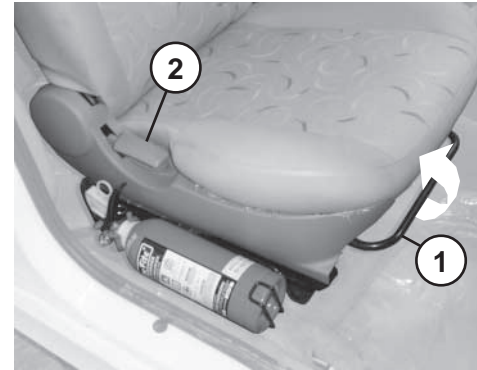

Front Seat Adjustment Levers

1. Lever for backward & forward movement
2. Lever for Seat Backrest angle

BEFORE DRIVING

Interiors and Accessories

Head-rest : (Adjustable on the front seat & fixed on the rear seat)

Head-rests are designed to help reduce the risk of neck injuries in case of accidents. For best protection, adjust the top of the headrest, so that it is in level with one's ears. To adjust the head-rest pull / push it to the desired position until it clicks. The head-rest can be adjusted up to 64 mm in steps of 16 mm.

If headrest is required to be removed (for cleaning fabric etc.) pull the headrest fully up, then push notch button with a thin punch while pulling the headrest up. To install follow the reverse order of removal.

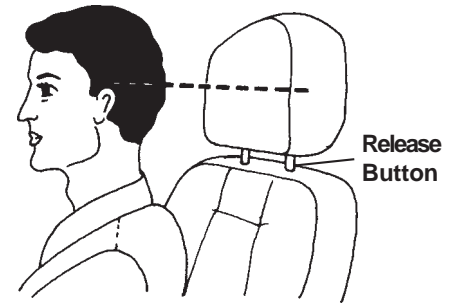

Avoid driving the car with the head-rest removed as it is a safety item. Do not attempt to adjust the head-rest while driving the car.

Rear Seat : (Split 60 : 40)

A cushion bench 60 : 40 split seat has been provided for the rear passengers. Any one of the split seat back can be folded by releasing the latch, on the 'C' pillar. For making more luggage space, the folded rear seat can be somersaulted further. Before summersaulting ensure that the front seats are at 3/4 the full travel towards rear.

For fixing the seat back upright, just push back the seat in position. It will get locked by itself.

Seat Release Latch on 'C' pillar



SOMERSAULTED POSITION

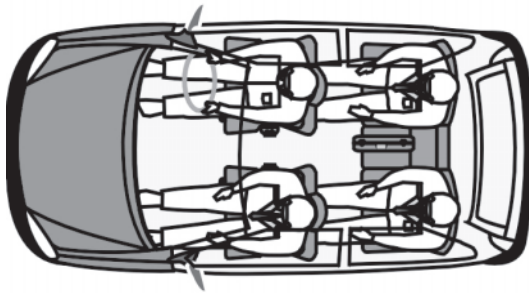

Luggage space before somersault operation

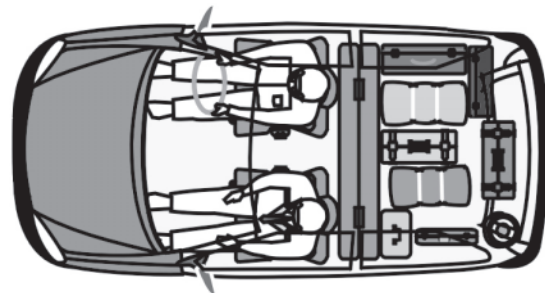

Luggage space after somersault operation

BEFORE DRIVING

Interiors and Accessories

Seat Belt

Seat belts have been provided on the front seats (with micro switch on driver's side for the deluxe model)



Always wear seat belts, while driving.

Seat belt adjustment :

1. Pull the tongue across your body and insert it into the buckle.
2. Check and ensure that the belt is not twisted.
3. Position the lap portion of the belt as low as possible across your hip bone.
4. Pull up the shoulder part of the belt to remove the slack.
5. Make sure that the belt goes over your collar bone and across the chest.
6. To unlatch the belt, press the red button on the buckle. Guide the belt to the pillar as it retracts.
7. Each belt should be used by one occupant only (such as front LH/RH, Rear outboard passenger LH/RH & Rear lap belt-location as per sketch). The belt must not be put round a child, seated on passenger's lap.
8. When the belt has been use in a serious accident or shows signs of severe fraying or of having been cut, replace the belt kit.
9. The belt must not be altered or modified during use.
10. The belts are meant (intended) for adult occupants only.

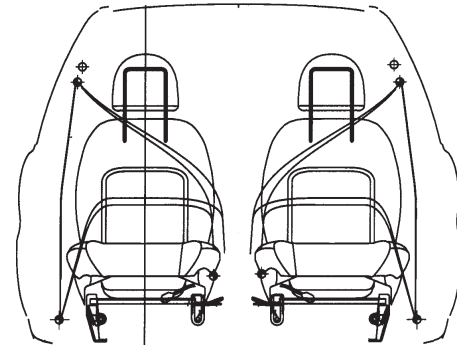

Front seat seat-belts arrangement

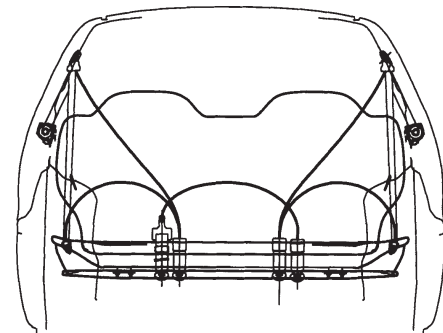

Rear seat seat-belts arrangement
viewed from rear

BEFORE DRIVING

11. The belts if required should be repaired, by authorised personnel only.
12. The belts should not be dismantled, if required, authorised personnel only should carry out disassembly and assembly from the vehicle.

 Do not wear your seat belt over hard or breakable objects in pockets or on your clothing. If an accident occurs, objects such as glasses, pens, etc. under the seat belt can cause injury.

Tailgate opening :

A tailgate opening lever is provided on the floor between the driver's seat and door.

Pull the lever up to unlock the tailgate.

Lift the tail gate by hand using the recess in the centre, near the bumper. The two telescopic balancers will open the door automatically.

To close and lock the tailgate push it down.

The tailgate can also be opened with the key.

When the tailgate is opened the parcel shelf also gets lifted up by the lifting cords, when the tailgate is closed it returns to its position.

 Ensure proper closing of parcel shelf while closing the tailgate.

Interiors and Accessories

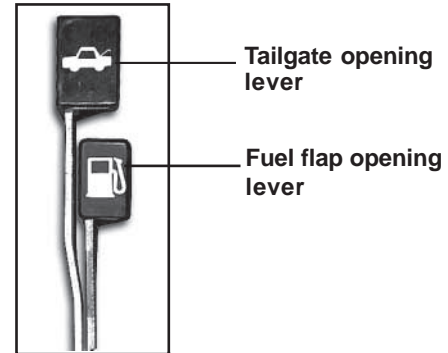

BEFORE DRIVING

Interiors and Accessories

Fuel flap opening :

The fuel flap is located on the left rear side of the car. The fuel flap can be opened by pulling the opening lever located near the tailgate opening lever and can be locked by simply closing the flap.

Music System :

A provision has been made for fitment of music system.

An internal antenna comes fitted on the front windshield glass on the inner side near the rear view mirror. Provision for the installation of speakers is made on the dash board on both the sides and on each of the front doors.

If the music system is originally provided in your vehicle, please refer manufacturer's manual for operation of the music system.

Electrical Accessory fitment :

Provision has been made in your car wiring to fit the following electrical accessories :

1. Engine Compartment Lamp
2. Front Fog lamp
3. Additional Horn (on LH side)
4. Reversing buzzer
5. Music System
6. Speakers
7. Immobilizer for vehicle security

For details of fitment please contact our nearest authorised service outlet.



Antenna



Provision for Music System

BEFORE DRIVING

Interiors and Accessories

Load Area Lamp (if installed)

A lamp is fitted in the luggage compartment to illuminate the luggage area, when required. To operate this lamp, a simple ON/OFF switch is provided along with this lamp. For the lamp to come 'ON' with the opening of tailgate, the switch should be in 'ON' position.

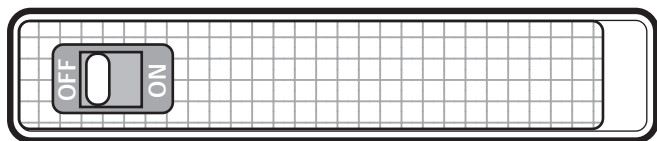

Load Area Lamp

Front Fog Lamps (if installed)

The Front fog lamps are provided with halogen lamps of H11 type to provide adequate light in the vehicle front. This enables to drive the vehicle during rains, fog, etc.



Fog Lamp

BEFORE DRIVING

Interiors and Accessories

Headlamp leveling switch (if installed) :

A motorised headlamp leveling arrangement with the setting knob at the dash board is provided on the LH side of steering column. As and when required, head lamp leveling, setting is done by rotating the knob to select one of the 3 levels marked in the switch depending upon the loading of the vehicle.

Head lamp leveling can be done with the head lamp in Low beam and in ON position.

NOTICE

- Setting should be done only when the car is stationary.
- Since the leveling switch alters the headlamp focus pattern under varying load conditions, it is advisable to select the correct position before starting a trip depending on load.

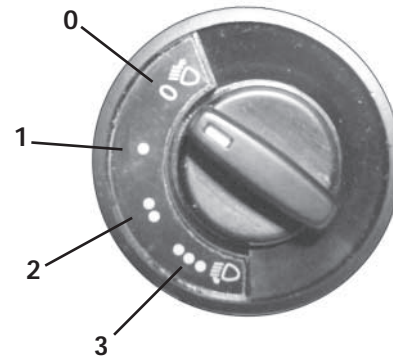
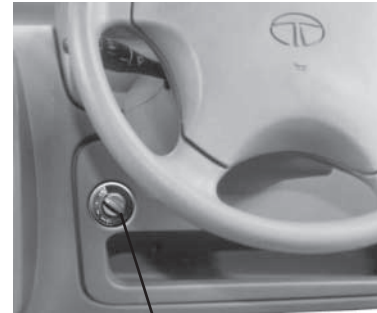



STARTING AND DRIVING THE CAR

■ STARTING & DRIVING

- Opening & closing the bonnet
- Check list
- Fuel level
- Engine oil level
- Engine coolant level
- Brake fluid level

■ STARTING & STOPPING

- Starting the engine
- Stopping the engine

■ PREPARING TO DRIVE

- Preparing to drive
- Running in instructions
- Gear shifting

■ FUEL ECONOMY

- Instructions to improve fuel economy

■ DRIVING IN ADVERSE CONDITIONS

- Driving through water
- Driving on a rainy day
- Night driving
- Towing the vehicle

■ DRIVING A DIESEL / PETROL CAR

■ DRIVING SAFETY

■ CAR SAFETY CHECKS

STARTING & DRIVING

OPENING & CLOSING THE BONNET

Opening :

1. Ensure that the car is in neutral gear with the parking brake applied.
2. Pull the bonnet release lever located under the right hand corner of the dash board. The bonnet will pop up slightly.
3. Raise the bonnet slightly and with your finger lift the secondary lock lever located under the bonnet centre.
4. Lift the bonnet up. Pull the bonnet stay rod from its clip and insert the free end into the slot in the bonnet, slide stay rod outward to secure.

Closing :

1. To close the bonnet disengage the stay rod & clamp it properly.
2. Lower the bonnet and drop it from a short height to shut.



Ensure that the bonnet is properly locked before driving.
Do not press the bonnet onto the bonnet lock.



Do not leave the engine running in a closed garage.

Opening & Closing the Bonnet

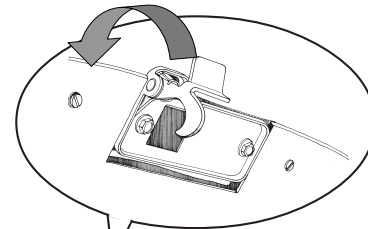
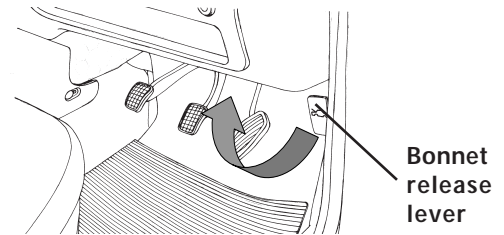

Check	Adjust	Ensure
1. Tyre pressure	1. Front seat	1. Bonnet is fully closed
2. Coolant level	2. Rear view mirrors	2. All doors are properly closed
3. Engine oil level		3. Seat belts are fastened
4. Brake fluid level		4. All switches & lamps are working
5. Water in windshield washer reservoir		5. Gear shift lever is in neutral position
6. Power steering oil level (if installed)		6. Parking brake is released
7. Battery electrolyte level		
8. Fuel level		

STARTING & DRIVING

Fuel Level & Engine Oil Level

Fuel Level :

Check fuel level on the gauge in the instrument panel. If the pointer is in the red zone and/or visual low fuel level warning indicator (Amber colour LED) glows, please ensure fuel filling at the earliest. Avoid driving with fuel at minimum level.

Engine Oil Level :

1. Open the bonnet. Pull out the dipstick and wipe it with a clean cloth or a paper napkin.
2. Insert it again to its original position.
3. Pull out the dipstick again and observe the oil level on the dipstick.
4. Top up oil if the oil level is below the mid point of min. and max. marks.

Note : Oil level should not exceed the max. mark. Always check the oil level when the car is on level ground and the engine is cold.

 Check the engine oil level if low oil pressure warning comes 'ON' while driving.

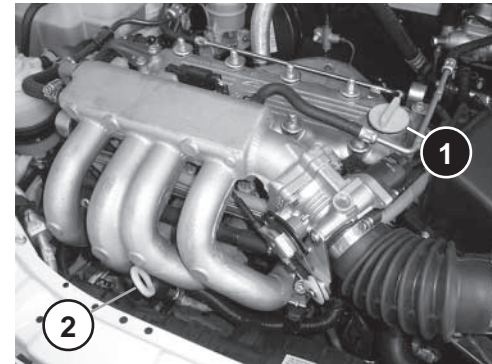

1. Engine oil filling cap 2. Dip stick

STARTING & DRIVING

Engine Coolant & Brake Fluid Level

Engine Coolant Level :

The coolant level is visible through the translucent reservoir. It should be between max. & min. marks. If it seems less, add premixed coolant into the auxiliary tank upto the max. mark. Put the cap back properly.



Never remove the filler cap when the engine is hot. Use only branded premixed ready to use coolant.

In case of an emergency, normal water can be used, but the system should be flushed & filled with proper coolant mixture at the earliest.

Brake Fluid Level :

The level of the brake fluid must be between the min. & max. marks on the side of the brake fluid container. If the level falls below the min. mark, add recommended brake fluid. (Refer chapter - Fuels, coolants & lubricants)

In case of spongy or hard pedal or low brake efficiency, please contact the nearest Authorised Service outlet.



1. Do not allow brake fluid to make contact with the skin or eyes.
2. Do not allow brake fluid to splash or spill on the paint surface as it will damage the paint. In case of spillage, wipe it off immediately.

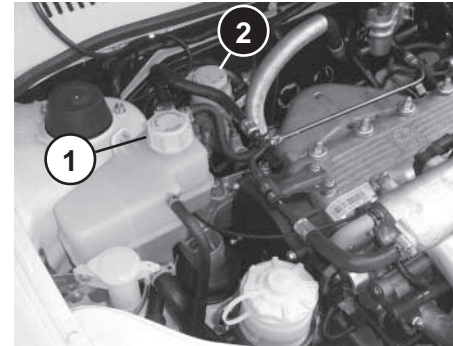

1. Engine Coolant filling cap
2. Brake Fluid filling cap

STARTING & DRIVING

Starting & Stopping

STARTING THE ENGINE

Before starting the engine :

- Apply the parking brake fully.
- Ensure that the gear lever is in neutral position.

Starting the engine :

- Press the clutch pedal fully and turn the ignition key to 'IGN' position. Ensure the "MIL" lamp turns "ON".

NOTICE

The Starter Protection System fitted in this car does not allow you to crank the engine until you fully press the clutch pedal.

- Do not press the accelerator pedal.
- Select the fuel operating mode by pressing the Fuel Selector Switch.
- Keep the clutch pedal fully pressed and crank the engine, if the engine cranks but fails to start then repeat the above procedure. Release the key as soon as the engine starts. Ensure that the "MIL" lamp is "OFF".

NOTICE

The Starter Protection System switches off the starter when it is cranked for more than 10 secs. In such a case, get the key back to OFF position and wait for 30 secs before cranking again. This safeguards the starter motor as cranking continuously for more

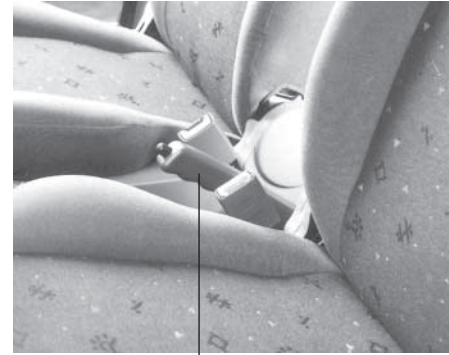

Parking Brake

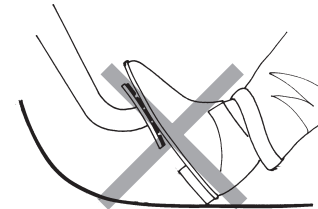

STARTING & DRIVING

than 10 secs can damage the starter motor. Also immediately release the key after the engine has started, otherwise the flywheel ring/ starter motor may get damaged.

IMPORTANT

It is normal that the starting time in LPG mode is longer than that in petrol mode by approximately 1 sec due to physical property of LPG. as a result, the engine has to be maintained in cranking state for a longer time when using LPG as starting fuel.

Starting the engine with a malfunction :

- Press the clutch pedal and turn the ignition key to 'IGN' position.
- Press the accelerator pedal by 1/4th of full travel. Do not depress the accelerator pedal fully down.
- Crank the engine. If the engine starts, car may be driven to nearest authorised service outlet, even though "Check Engine" lamp is indicating a malfunction.
- In the above condition engine may stall if the accelerator pedal is released back to idle position.
- If engine stalls, repeat the above procedure from beginning & drive the car without releasing the accelerator pedal to "Idle" position.

Brake Fluid Level & Stopping the engine

Stopping the Engine :

- Let the car come to a stop and engine to idle.
- Turn the key to 'OFF' position.

Parking :

- Park the car in a safe place. Switch on the indicator signal before turning to park.
- Apply the parking brake.
- Ensure that all window glasses are closed and all lamps are turned 'OFF'.
- At night, put on the parking lights if required.
- Remove the key from the ignition switch.
- Place wheel chokes at the wheels if parked on a slope.

NOTE

Read the Parking Brake section in "BEFORE DRIVING" for precautions on how to park the vehicle on a slope.



Do not leave the key inside the car.
Do not leave children unsupervised in the car.
Avoid parking the car over inflammable materials, such as dry leaves, grass etc., as the exhaust system is hot enough to initiate "FIRE".

Preparing to Drive :

The following checks and adjustments should be carried out before you start driving the car.

- Ensure that the windshield, all mirrors, windows and outside lights are clean. Check & adjust rear view mirrors.
- Ensure that the windshield washer reservoir is full.
- Ensure that the bonnet is properly closed.



Do not put excessive pressure on top of bonnet to avoid damage.

- Check that any items that you may be carrying inside, are fully secured.
- Check & adjust seat.
- Ensure that all doors are locked properly.
- Fasten seat belt properly.
- Ensure that all gauges and indicator lights are working.
- Check for blind areas being unobstructed in front and rear of the car.
- Release the parking brake.
- Before driving off check in the rear view mirror, for oncoming traffic. Switch on side indicator signal when getting into main stream of traffic.

Running-in instructions :

During running-in period i.e. first 1000 km. follow the running-in instructions given below :

- A. 1. After starting the engine do not rev it up. Warm up gradually at idling speed.
2. Avoid sudden acceleration and full throttle.
3. It is always preferred not to rev up a cold engine lest engine bearings get affected.
- B. Recommended car speeds during running-in period :

Gear	Speed (kmph)
1st	20
2nd	40
3rd	60
4th	80
5th	90

STARTING & DRIVING

Preparing To Drive

Gear Shifting :

All forward gears being synchronised, provide for easy and effortless gear shifting. Always remember to press the clutch pedal fully while shifting the gears and also to release the clutch pedal gently.

Avoid sudden clutching i.e. abrupt release of depressed clutch pedal.

Do not shift into reverse gear when the car is moving forward or when the engine is not at idling r.p.m. A 5 second pause after declutching will ensure smooth engagement of the reverse gear. Change gears at appropriate gear change speeds.

Note : There is an interlock provided between fifth and reverse gear to prevent accidental shift from 5th gear to reverse gear. (Shifting from reverse gear to 5th gear is possible)

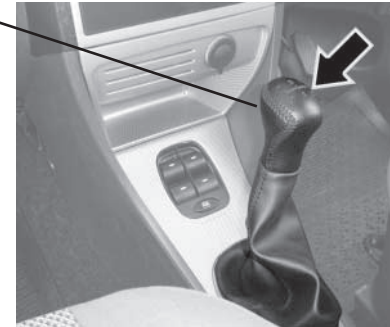
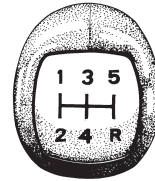

Appropriate gear change speeds for good pick-up :

Speed (kmph) Upshift			Speed (kmph) Downshift		
1st to 2nd	-	25	2nd to 1st	-	15
2nd to 3rd	-	50	3rd to 2nd	-	40
3rd to 4th	-	70	4th to 3rd	-	70
4th to 5th	-	85	5th to 4th	-	80

Recommended maximum speed, during normal operation.

Gear	Speed (kmph)
1	35
2	60
3	85
4	120
5	125

INSTRUCTIONS TO IMPROVE FUEL ECONOMY :

Your car's fuel economy is mainly dependent on your style of driving.

To operate your car as economically as possible, use the following driving suggestions.

Avoid Excessive Idling :

Switch OFF the engine if you have to stop for more than a minute.

Avoid fast starts & unnecessary stops :

Start off slowly from traffic lights or stop signs to prevent increased fuel consumption and reduced engine life. Avoid unnecessary deceleration (stopping or slowing down) and then acceleration which uses more fuel.

Always maintain clean air-cleaner :

The amount of air supplied will reduce due to clogged air-cleaner, resulting in waste of fuel due to incomplete combustion.

Avoid incorrect tyre pressures :

Under-inflated tyres result in increased running resistance of the tyres, leading to wastage of fuel.

Always have the engine tuned correctly through recommended maintenance at an Authorised Service outlet.

Proper Driving Practices :

Keep a safe distance from other vehicles to avoid braking suddenly.

Do not rest your foot on the clutch pedal. It does not allow full engine power to be transmitted to the vehicle and reduces clutch life.

Fuel economy speeds :

Gear	Speed (kmph)
1st	10
2nd	25
3rd	35
4th	50
5th	60

MPFI System



The multi point fuel injection system has been designed to meet various load and speed conditions of the engine and doesn't require any regular maintenance. MPFI system should be serviced by authorised service personnel only, if required.

TIPS RELATED TO FUEL SYSTEM MAINTENANCE :

Basically, the fuel system of the vehicle consists of the following main components :

1. Fuel tank
2. Fuel Filter
3. Fuel Pump
4. Fuel Rail
5. Fuel pressure regulator and
6. Fuel injector.

The following instructions are to be followed for reducing problems related to the fuel system.

- a) Avoid keeping the fuel tank empty and preferably keep it topped up as frequently as possible.



Empty fuel tank may lead to inner corrosion of the tank. The rust particles thus formed may result in frequent clogging of fuel filters. If the dust particles enter the system, it may result in malfunctioning of the MPFI system.

- b) Replace clogged fuel filters to prevent inconsistent fuel delivery from the fuel pump.

Driving Through Water :



- Never venture to drive through water when it flows above the stone guard or above the tyre centre line.
- The engine may get seriously damaged if attempts are made to cross through deep water.
- If at all the situation demands that you have to drive through water even at great risk then,
- Keep the engine in fast idling and 'crawl' in low gear.
- After driving through water apply the brakes several times to dry the liners and to regain original braking.
- Check the engine and transaxle for any water entry.



Do not attempt to start the engine if the car gets flooded due to water.

- Tow the car to a safe place.
- Take the car to the nearest Authorised Service outlet to check for entry of water in the engine.
- Lubricants in the engine and transaxle need to be changed in case of water entry.



STARTING & DRIVING

Driving In Adverse Conditions

Driving on a Rainy Day :

- ⚠️ • Check wiper blades for proper functioning.
- Check brakes, steering and windows.
- Check tyres for wear and tyre pressure. Worn out tyres are unsafe on wet roads.
- Avoid harsh braking and sharp turns. It may cause loss of steering control and lead to the car skidding.
- For slowing down, shift to lower gears and apply brakes gently.
- Keep lights on if visibility is poor.
- Use heater and demister if required to clear off mist on the windshield.

Night Driving :

- ⚠️ • Dip the head lamp for oncoming traffic during night driving.
- Maintain a speed such that you can stop within illuminated distance of the head lamps.
- Use head lamp main/dip beam to alert other users on turns/cross roads, etc.
- Use side indicators to indicate lane change or turning.
- Put on the hazard warning switch in case of hazardous parking or if your car is disabled to warn passing traffic. Put on the fog lamps (for Deluxe version) if required.



STARTING & DRIVING

Towing the Vehicle :



- For towing a car, the best way is to use a wrecker.
- Alternatively use a rigid tow bar.
- Avoid using a flexible cable or rope as your car may crash into the car towing your car when it stops suddenly.
- Switch 'ON' the hazard warning signals of both the cars to warn other road users.
- Where possible, keep the engine idling so that power steering assistance and brake vacuum are available.
- Limit the speed to 20-30 kmph.
- In case of brake failure, use the parking brake to control the car.

Driving In Adverse Conditions



Front Towing Hook



Rear Towing Hook

DRIVING SAFETY

Seat-Belt

Seat-belts are life saving equipment and their use reduces the chance of injury and severity of injury in case of an accident. It is strongly recommended that all the car occupants should always wear the seat-belt, while car is in motion.

Influence of Alcohol

Avoid driving under the influence of alcohol or drugs. Alcohol and drugs will severely impair your control on the vehicle and increase the risk of injury to yourself and others.

Mobile phones

Avoid using mobile phones while driving. This could divert your attention from the road and result in an accident.



Fatigue 'Rest Revive Survive'

Do not attempt driving when you feel tired or sleepy. Long distance driving can tire you very much and fatigue can dull your reflexes and judgment. Take a break and get refreshed at intervals.

CAR SAFETY CHECKS

Windshield/wiper/windshield washer

Always keep windshield glass clean to avoid any distraction in visibility. Ensure proper working of wipers and condition of wiper blade. Ensure that windshield washer reservoir is full. Do not operate wiper when the windshield glass is dry, this could damage the windshield.

Headlights

Keep headlight lenses clean. Check for operation of headlamp in both high/low beam conditions. Check for correct focusing of headlamps. Use only recommended type of bulbs. Do not use the high beam unless it is inevitable. Its dazzle may glare the driver of the oncoming car thus causing an accident.

Side indicators / Hazard warning

Ensure that all side indicators/hazard warning lights are always in working condition and they are used when required.

Horn

Ensure the horn is working properly. Horn provides safety to other road users by alerting your presence.

Brakes

Ensure the brakes are in working condition. Check brake fluid level in reservoir. Do not drive the car when brake warning lamp is 'ON'.

Tyres

Check the condition of tyres for any abnormalities. Maintain correct tyre pressure, it is very important particularly when subjected to extreme

conditions, such as high speed, high load and high outside temperature. Do not use worn or bald tyres on the front wheels.

First Aid Kit :

First aid kit is provided in your car. This is for use in case of minor injuries. It is to be regularly checked for any disintegration and should be updated regularly.



Advance Warning Triangle :

There is an advance warning triangle provided along with your vehicle. In case there is a breakdown and the vehicle is parked at the side of road,

then the triangle is to be kept as per instructions given below :

Remove advance warning triangle from case and assemble.

Place the triangle on the road behind the vehicle when it stranded on the road. The triangle must be at least 50 meters behind the vehicle in the same lane of traffic.

Increase the distance to 150 meters on a highway or if a bad/hill top obscures the view.





MAINTENANCE & CAR CARE

■ MAINTENANCE POINTS

- Engine compartment
- Engine compartment lamp
- Windshield washer
- Air Filter
- Engine cooling system
- Engine oil and oil filter
- Belt tension
- Fuel system
- Transaxle oil
- Cluth & clutch adjustment
- Brake & brake adjustment
- Power steering
- Battery
- Catalytic Converter
- Spark plug
- Carbon canister
- LPG filter
- LPG pressure regulator diaphragm

- Starting the engine with jump leads
- Wheel change
- Wheel alignment
- Wheel balancing
- Tyres & tyre rotation
- Spare wheel
- Repairing a tyre / tube
- Fuses & Relays
- Head lamp and head lamp adjustment

■ CAR CARE

- Washing
- Polishing
- Cleaning of carpets
- Cleaning of glass
- Wiper care
- Paint care

ENGINE COMPARTMENT - INDICA LPG

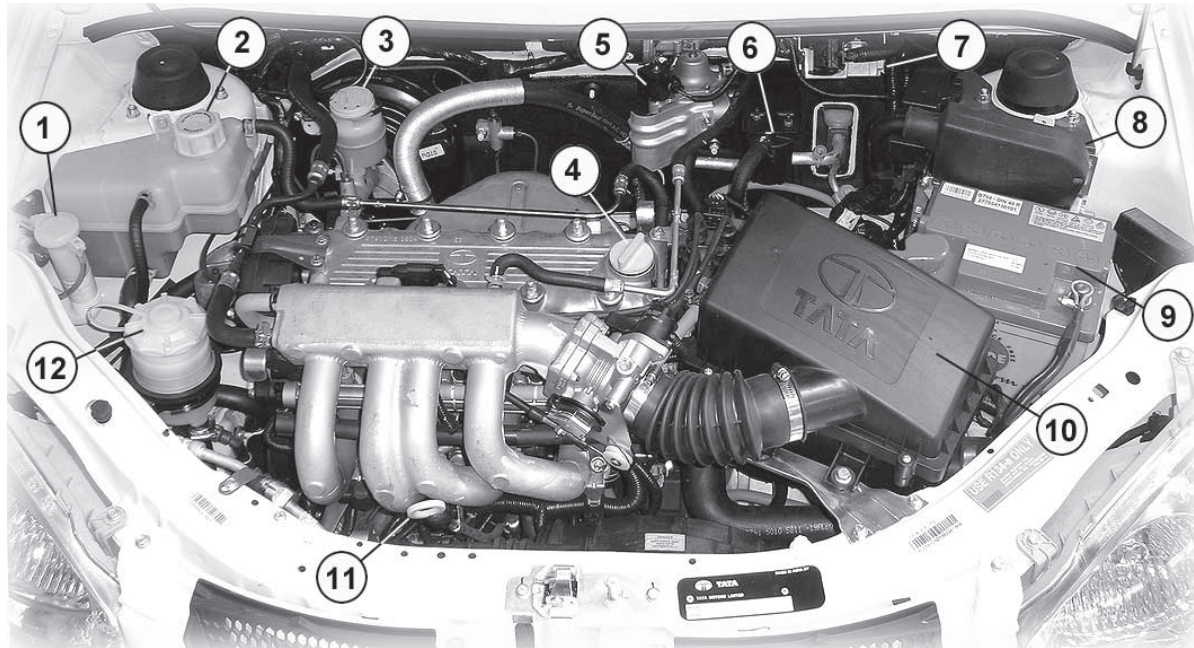

1 Window Washer Fluid container

4 Engine Oil Filling Cap

7 LPG - ECU

10 Air Filter

2 Engine Coolant Tank

5 LPG Regulator

8 Main ECU

11 Dip Stick

3 Brake Fluid Container

6 LPG Fuel Filter

9 Battery

12 Power Steering Fluid Container

MAINTENANCE & CAR CARE

Engine Compartment Lamp & Windshield Washer

ENGINE COMPARTMENT LAMP : (if fitted)

Engine compartment lamp is provided to illuminate the engine compartment.

A push - pull type switch is provided to operate the lamp.



Do not forget to switch 'OFF' the engine compartment lamp before closing the bonnet.

A provision has been made for installation of engine compartment lamp in standard version.

WINDSHIELD WASHER :

Windshield washer fluid container is located behind the front right hand side panel and its filler neck is provided near auxiliary tank in the engine compartment.



Do not add detergent or any solvent in the windshield washing water.

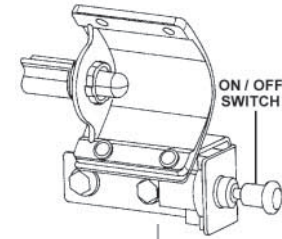

Engine Compartment Lamp



Windshield Washer Fluid Container

AIR FILTER :

The air filter element should be periodically cleaned. Replace the air filter element with a new one, if necessary.

Always use a genuine air filter element.

The air filter is located on the LH side of the engine compartment.

Replacement of Air Filter Element :

- a) Remove the cover of the air filter, by loosening the screws.
- b) Remove the air filter element.
- c) Clean it gently by tapping. Clean air filter cover and air ducting.
- d) Check the element for puncture or pin holes by holding against a bright light source.
- e) If found to be OK, reinstall the filter element. Fit the cover with screws.

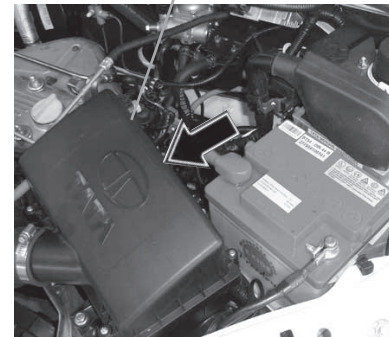
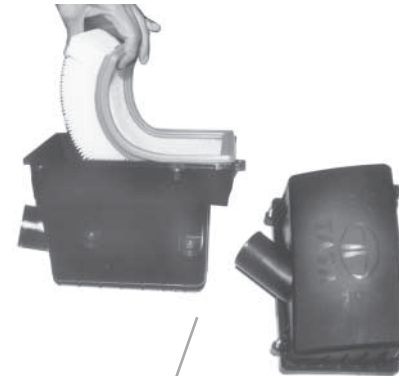

Air Filter



- a) When a car is driven under dusty conditions, frequent replacement of the air-cleaner element may be required.
- b) Clogged air-cleaners lead to greater intake resistance and result in increased fuel consumption. Using low pressure compressed air, blow off dust on the air cleaner element. If the air cleaner element appears to be choked, replace it with a new one.

MAINTENANCE & CAR CARE

Engine Cooling System

ENGINE COOLING SYSTEM :

If engine overheating occurs, there could be a fault in the cooling system which may be due to :

1. Insufficient coolant in the cooling system or dirt/scales having accumulated inside the cooling water passages especially in the radiator core.
2. Choking or damage of radiator passages.
3. Defective thermostat.
4. Non operation of electrically operated fan. (40 Amp. fuse blown)
5. Coolant leakage.
6. Auxiliary tank cap not sealing properly.
7. A.C. condenser fan not working.
8. Excessive refrigerant charging in the A.C. system.
9. Improper bleeding of the cooling system.

Prevention of Rust Formation :

To prevent rust formation use the branded premixed engine coolant in the radiator.

This is sufficient to operate the car upto -40°C .

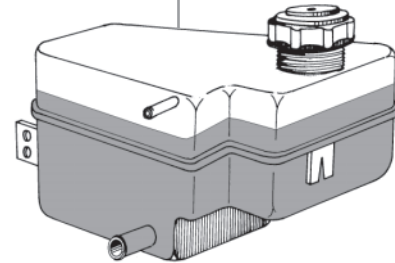
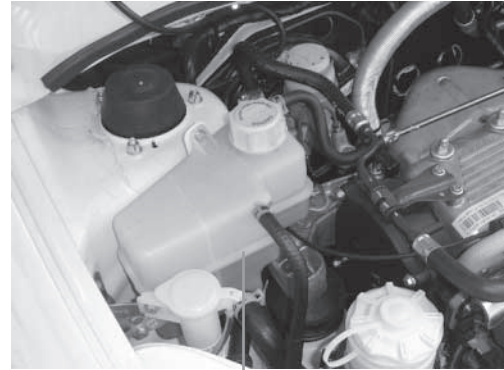

Engine Coolant Tank

MAINTENANCE & CAR CARE

Petrol Fuel Filling Cap

PETROL FUEL FILLING :

The fuel filler cap is located on the left rear side of the car. The fuel filler lid can be unlocked by pulling the opening lever located on the out-board side of the driver's seat and locked by simply closing the lid.

! Remove the fuel filler cap slowly. The fuel may be under pressure & may spray out, causing injury if the cap is opened suddenly.

- Switch OFF the engine when refueling.
- Do not use your mobile phone when you are at a Filling station

! The fuel cap is of the non vented type. Use correct genuine cap for replacement.

- To remove the fuel filler cap turn the cap anti-clockwise. Turn the cap slowly to allow any residual pressure to escape.
- To install turn the cap clockwise till a click sound is heard.

Petrol is extremely flammable. Do not smoke when refuelling and make sure there are no open flames or sparks nearby.

If you need to replace the fuel cap, use only a cap specified for your car. Using an improper fuel cap can cause a serious malfunctioning of the fuel system. You can get the correct replacement from an Authorised Service outlet.

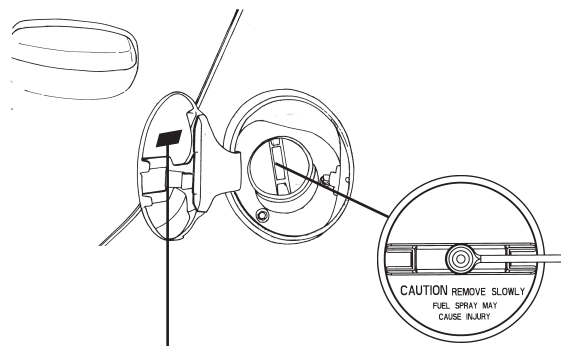

STICKER
UNLEADED PETROL ONLY - FOR PETROL
VERSION WITH CATALYTIC CONVERTER

MAINTENANCE & CAR CARE

LPG Fuel Filling

LPG FILLING :

LPG filler valve is located at the rear on the right hand body side of your car. LPG filling will stop automatically once the LPG tank is filled to 80% of its capacity.

The LPG cylinder capacity of your car is 31 litres. If the LPG is filled after service / repairs of the LPG system, please check all joints for leakage by applying soap solution or by using an electronic instrument. Example -'Leakator - 10'. or equivalent.

NOTICE

Keep the Ignition switch in "OFF" condition during LPG refilling

FUEL TANK CAPACITY :

Petrol tank capacity = 37 Litres

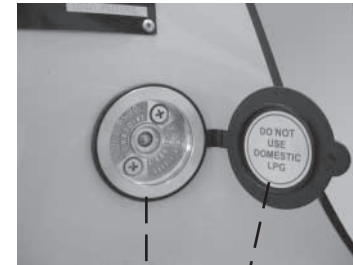

STICKER :
DO NOT USE DOMESTIC LPG



LPG Fuel Filling Cap

Transaxle Oil :

Checking of Oil Level :

1. Clean the oil level plug and the surrounding area.
2. Remove the oil level plug and check whether oil is dripping out.
The oil level must not be below the filler plug.
Add oil to bring it to the required level.
3. Tighten the oil level plug to 3 - 4 mkg. torque.

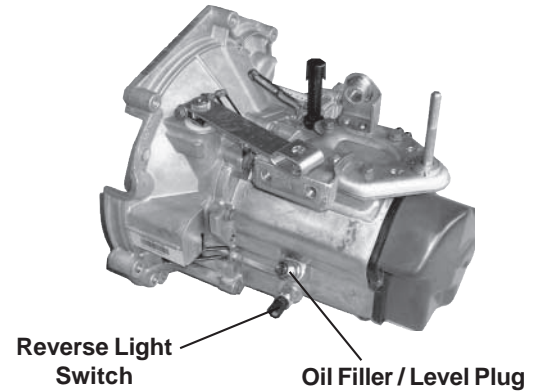

CLUTCH :

Your car is provided with a single plate dry friction diaphragm type, pre-loaded release bearing clutch which is mechanically actuated by a cable connecting the clutch pedal & the clutch release lever. There is no free play in the system and hence no clutch pedal free play adjustment is required although the clutch pedal height from the floor has to be adjusted as clutch lining wears. The clutch pedal height from the floor keeps on increasing as the clutch lining wears. However, ensure that clutch pedal has free movement when lifted upward



Do not ride the clutch. It will cause premature clutch wear.
Do not release the clutch suddenly.

BRAKES :

Dual circuit, diagonal split hydraulic brakes through tandem master cylinder have been provided. The front brakes are disc brakes with floating type calipers while the rear brakes are drum brakes with automatic adjustment.

No adjustments are required for front & rear brakes.

The parking brake is a mechanical lever type, console mounted, cable operated, acting on rear wheels.

To operate, pull up.

To release pull up, press the button, lower handle then release the button & handle.

Pressure reducing valves are provided on both circuits for the rear brakes to avoid locking of wheels & skidding of the car.

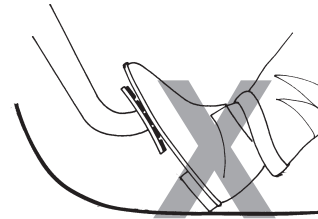

NOTE : Vacuum Assistance : The hydraulic brake system of your car is assisted by a vacuum booster which reduced the effort of driver during braking. In the unlikely event of disruption in supply of vacuum to the booster (e.g. stoppage of engine, or failure of vacuum hose) this assistance will still be available but only for one or two brake applications to bring the vehicle to a stop. Beyond this, vacuum assistance will not be felt by the driver and brakes will appear to be hard/ineffective. In order to stop the vehicle effectively the driver will have to apply a much higher force on the brake pedal (roughly 5 times the normal effort)



Never drive the vehicle in engine switched "OFF" condition.

MAINTENANCE & CAR CARE

Brake Fluid & Power Steering

Brake Fluid :

Check the level of brake fluid in the brake fluid container.

It should be between the Min. and Max. marks.

If not, then add brake fluid. Clean the area surrounding the cap before opening the cap. Always use fresh brake fluid and tighten the cap fully, otherwise moisture from the atmosphere will be absorbed by the brake fluid, making it unserviceable.

In case of spongy or hard pedal or low brake efficiency, please contact the nearest Authorised Service outlet and get the defect rectified.

POWER STEERING (if installed)

Power steering is fitted for lighter steering effort and easy manoeuvrability, during driving and also help absorb the road shocks. The system consists of steering gear box, hydraulic pump and hydraulic tank. Pump drive is through the poly 'V' belt from the engine. Power assistance is available during normal operating conditions. In case of failure in the hydraulic system, the steering can be operated mechanically to bring the car to an Authorised Service outlet.

Check the Power Steering Oil level in the Power steering oil container. It should at MAX level.

Brake Fluid Container

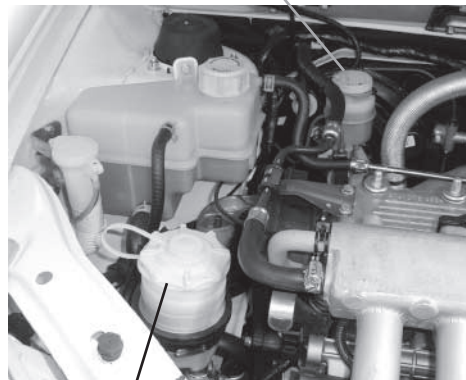

Power Steering Fluid Container



Report any external leakage to the nearest Authorised Service outlet.



Do not allow fluid level to drop significantly or run out of the reservoir during the above operation. This may induce air into the system.

Severe damage could occur to the power steering pump due to dry running (Running without sufficient oil and due to severe cavitation on account of air entry due to low oil level). This could lead to loss of power assistance, damage and failure of the power steering system.

Do not start the engine without oil in the power steering system. This will result in serious damage to the pump. In case of an emergency, disconnect the pump drive belt and then start the engine or drive slowly as vacuum assistance for brake would not be available.

Always use recommended oil from sealed containers. Any contaminated oil poured in the system will result in damage to the pump and gear box.

Avoid mixing of different brands of oils.

BATTERY :

Check the battery for proper electrolyte level and corrosion on the terminals.



During normal operation, the battery generates gas which is explosive in nature, a spark or open flame can cause the battery to explode causing very serious injuries.

Keep all sparks & open flames and smoking materials away from the battery.

Getting electrolyte in your eyes or on the skin can cause severe burns. Wear protective clothing and a face shield or have a skilled technician to do the battery maintenance.

The battery contains sulphuric acid (electrolyte) which is poisonous and highly corrosive in nature.

1. Check the battery for electrolyte level against the marking on the battery outer case.
2. Check the battery terminals for corrosion (a white or yellowish powder). To remove it, cover the terminals with a solution of baking soda. It will bubble up and turn brown. When this stops wash it off with plain water. Dry off the battery with a cloth or paper towel.
Coat the terminal with petroleum jelly to prevent future corrosion.

MAINTENANCE & CAR CARE

Battery

Use a proper wrench to loosen and remove cables from the terminals. **Always disconnect the negative (-ve) cable first and reconnect it last.**

Clean the battery terminals with a terminal cleaning tool or wire brush.

Reconnect and tighten the cables, coat the terminals with petroleum jelly.

If you need to connect the battery to a charger, disconnect both cables to prevent damage to the vehicle's electrical system.

Note : Charging the battery with the cables connected can seriously damage your vehicle's electrical/electronic equipment.



Swallowing electrolyte can cause fatal injury if immediate action is not taken.

Do not reverse the battery connection on the vehicle as it may damage the vehicle electricals.

Note : -ve terminal is connected to the body/cab.



Battery

Starting the Engine with Jump Leads :

The engine with a discharged battery may be started by transferring electrical power from a battery in another car.

This may be dangerous as any deviation from the following instructions could lead to personal injury resulting from any battery explosion, as well as damage to the electrical systems in both cars.



Do not allow battery electrolyte to come in contact with eyes, skin, fabrics or painted surfaces. The fluid contains sulphuric acid which can cause injury and severe damage. Wear rubber gloves, to avoid risk of contact.

- To lessen the risk of injury, wear eye protection when working near any battery.
- Make sure that the battery providing the jump start has the same voltage as the battery in your car (12 V). Its capacity must be approximately the same as the original battery capacity. The voltage and capacity are given on the batteries.
- Do not disconnect the discharged battery from the car.
- Switch off all unnecessary electrical loads.
- Do not lean over the battery during jump starting.
- Do not allow the terminals of one lead to touch those of the other lead.
- Apply the hand brake. Keep the gearshift lever in neutral.

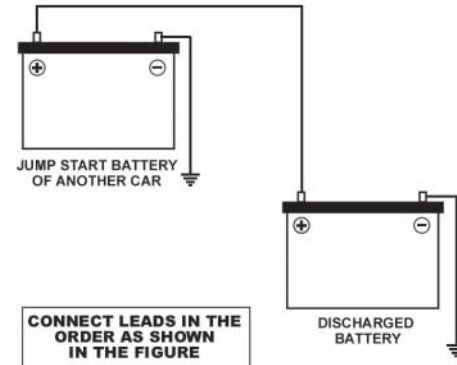

Connect leads in the order as shown in the sketch :

- Do not connect the lead to the negative terminal of the discharged battery.
- The connection of the -ve lead point should be as far away from the discharged battery as possible and close to the starter motor on engine/transaxle.
- Route the leads so that they cannot get caught by the rotating parts in the engine compartment.
- The engine of the car providing the jump start can be allowed to run during starting.

Attempts to start the engine of the car with the discharged battery should be made at intervals of one minute. After starting, allow both engines to idle for approximately 3 minutes with the leads still connected.

Catalytic Converter :

The catalytic converter is fitted on your car to reduce exhaust pollution. The catalytic converter will quickly heat up after starting to ensure that it operates correctly during the warm up phase of the engine. **On a car with a catalytic converter, the fuel tank filler neck is of reduced diameter compatible with standard unleaded petrol supply nozzle.**



Even one time use of leaded petrol may cause permanent damage to the catalytic converter. Hence use unleaded petrol only.

Care & Maintenance :

- Use Unleaded Petrol only, since use of Leaded Petrol will damage (poison) the Catalytic Converter permanently.
- Consult an Authorised Service Outlet at the earliest when,
 - Engine misfires or runs irregularly, following a cold start,
 - A significant loss of Power is noticed.
- In the event of above symptoms, drive the car at slow speed without rapid acceleration. If the vehicle is continuously run with misfiring, it may cause overheating of shell, carpet etc. resulting into fire.

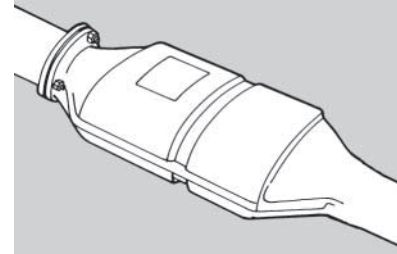

Catalytic Converter

Avoid

- Push start or tow-starting the vehicle. (Use jump leads).
- Repeat (not more than 3 times) starting of the Vehicle. Investigate the cause for difficulty in starting & rectify the same.
- Long idling (to warm-up). If the engine is running rough, after a cold start.
- Switching "off" the ignition when driving down the hill. (This will not save fuel).
- Fuel tank getting almost empty.
- Idling the engine with any of the Spark Plug Cable disconnected, manually, during diagnostic test. (Use appropriate test equipment).
- Pre-Coating/Painting of Catalytic Converter.

Parking Warning :

Avoid parking the vehicle over inflammable materials, such as dry leaves, grass, etc., as the exhaust system is hot enough to initiate "FIRE".

SPARK PLUG (Petrol Engine) :

Spark Plug	- MICO*
Spark Plug No.	- FR 6 DC 4
Spark Plug Gap	- 0.7 mm to 0.8 mm

You should inspect the spark plugs periodically for carbon deposits. When carbon accumulates on the spark plug, a strong spark will not be produced. Remove carbon deposits using a spark plug cleaner.

Spark Plug Replacement :

1. Clean up any dirt or oil that is collected around the spark plug caps.
2. Pull out the spark plug cables by gripping at the connector.
3. Remove the spark plug with the help of a special socket.
4. Check and adjust the gap, it should be 0.7 mm to 0.8 mm.
5. Replace the spark plug if the gap is more than 1.2 mm.
6. Fix the spark plug and tighten it to the torque of 25 Nm (dry).

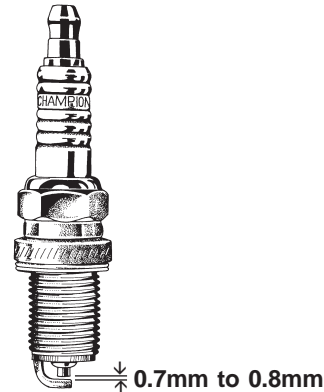

Spark plug

7. Fit the spark plug cable, until a "click" sound is heard. Repeat the procedure for the other spark plugs.



Tighten the spark plug carefully. Overtightening can damage the threads in the cylinder head. A loose spark plug or loose spark plug cable can affect combustion and cause damage to engine and catalytic converter.

CARBON CANISTER

As petrol evaporates in the fuel tank, hydrocarbons are discharged into the atmosphere. The carbon canister stores these hydrocarbons from the fuel tank.

Air drawn through the carbon canister into the engine should be controlled to maintain exhaust emissions within desired limits as well as to ensure good driveability.

The carbon canister should be replaced at an Authorised Service outlet.

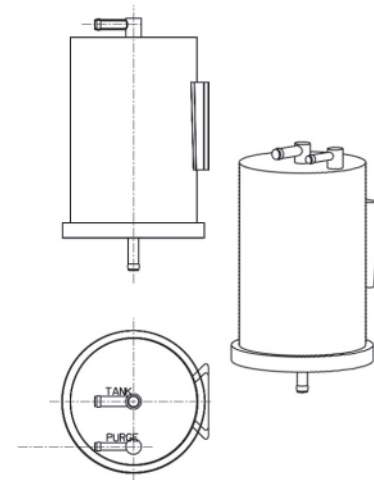

Carbon Canister

WHEELS & TYRES :

Always use only the recommended size of wheel rims & tyres. Use of non-recommended rims and tyres may have an adverse effect on car safety and furthermore could infringe on car regulations.

Spare Wheel Location :

Your car's spare wheel is mounted as shown in figure on a *cross member* that is located just behind the rear seat and has its mounting on the rear suspension towers. It is held in place by a single stud and tightened using a nut. Ensure that the wheel is seated properly on the bracket & is resting on the plyboard floor.

Spare Wheel removal procedure :

Follow these steps to remove the spare wheel of your car

- a. Remove the nut on plate that holds the spare wheel with the cross member.
- b. Once this nut is removed, the wheel that is resting on the ply board covering the LPG tank is now free.
- c. The wheel can now be lifted and taken out.

NOTE : Once the spare wheel is repaired and is ready to be refitted, keep the direction of the air filling nozzle outwards for easy air filling.

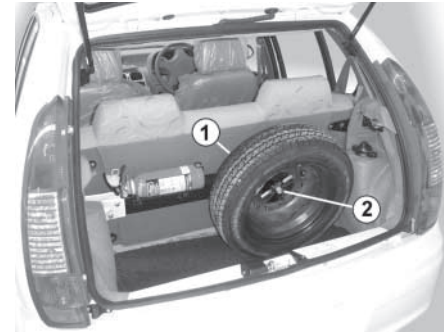

1. Spare Wheel

2. Spare Wheel Mounting Nut

Jack removal procedure :

Your car's jack is located behind the spare wheel and is mounted on the floor. You can have access to the jack once the spare wheel is removed. To remove the jack, first unscrew the hook end. While refitting, position the jack below the support rod & screw the jack till it is firmly fitted.

Wheel Change :

When changing wheels, use the jack provided with the car. The jack with handle is located on tailgate inner sill.

- Park the car on a safe level ground. Engage 1st gear and also apply the parking brake. Place wheel chocks behind the rear wheels and in front of the front wheels.
- Loosen the wheel pins of the wheel to be changed slightly. Keep the spare wheel to be fitted nearby.
- Jack up the car by placing the jack at the appropriate location.
- Remove the wheel pins, the wheel rim cover and the wheel.
- Fit the new wheel, wheel rim cover and tighten the wheel pins.
- Lower the jack and tighten the wheel pins to 8 mkg. torque.



1. Spare Wheel

2. Jack & Handle



A. Front Jacking Point
B. Rear Jacking Point

NOTE : The jack should never be supported on any of the body sheet metal components. This can cause damage to the body.

Do not apply oil on the wheel pins. Wipe off the oil if present.

- The jack should be placed below the body sill behind the front wheel tyre for front wheel changing and before the rear wheel tyre for rear wheel changing. Please refer to the sticker (Jack location) fixed on the jack.



Do not work under the jacked up car without proper support.

Correct wheel alignment helps to ensure uniform tyre wear. You should get your car's wheel alignment checked regularly as per recommendation.

In case uneven tyre wear is observed, the vehicle's wheel alignment should be checked as soon as possible.

Wheel Balancing :

Wheels are balanced at the factory. They have to be rebalanced as per recommendations.

The wheels should be checked for balance if a tyre or tube is repaired.

Whenever a tyre or wheel rim is changed, the tyre needs to be balanced.

1. Permissible imbalance for tyre with rim = 125 gm. cm. (max.)
2. Total balance weight should be within 80 gm on each side.
3. Relocate the tyre on the wheel rim if the weight required to balance is more than 80 gm.
4. Balance weights are available from 5 gm to 80 gm, in steps of 5 gm.
5. Do not use more than one balance weight on one side.

Tyres :

Check for inflation and condition of your car tyres periodically.

Inflation :

Check the pressure in the tyres when they are cold.

Refer to the tyre information label fitted on the driver side doorpost for correct cold tyre pressure.

Recommended Tyre Pressures : (with cold tyres)

Refer page no. 12

You should have your own tyre pressure gauge and use it at all times. This makes it easier for you to tell if pressure loss is caused by a tyre problem and not by variation between gauges.

Keeping the tyres properly inflated gives you the best combination of riding comfort, handling and tyre life.

Over inflation of tyres makes the car ride bumpy and harsh. Tyres are more prone to uneven wear and damage from road hazards.

Under inflated tyres reduce your comfort in car handling and are prone to failures due to high temperature. They also cause uneven wear and more fuel consumption.

Inspection :



Every time you check inflation pressure, you should also examine tyres for leakage, damage, foreign objects & wear.



You should look for :



- Bumps or bulges in the tread or the side of the tyre. Replace the tyre if you find either of these conditions.
- Cuts, splits or cracks in the side of the tyre. Replace the tyre if you notice this on the fabric or cord.
- Excessive tread wear or non uniform tyre wear.

Tyre Rotation :

To help increase tyre life and distribute wear more evenly you should have tyres rotated at specified intervals or earlier depending on the operation of car and tyre wear pattern.

The illustration shows how to rotate tyres when a normal spare wheel is included in tyre rotation.

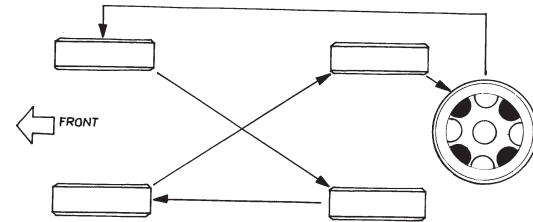

Tyre Rotation

Your car's LPG system is protected against short circuit / overload by a fuse (15 A) fitted in the fuse box that is located behind the dash board on the right hand side.

To replace a blown fuse :

1. Open fuse box cover.
2. Identify blown fuse from its melted wire.
3. Remove the blown fuse & replace with one of similar amperage.

(For location of the fuse refer next page)

Take your car to a TATA Authorised service centre to find out the reason for the fuse to blow & repair the problem.

Fuse replacment should prefreably be done only at TATA Authorised service centre

When the fuse blows OFF, the following may occur

- All LEDs on the switch will go OFF.
- If your car is running in LPG mode when fuse blows OFF, the LPG system will shut down and will automatically shift to Petrol mode.
- In such a case, you can start the car only in Petrol mode
- If your car is running in Petrol mode when fuse blows OFF it will keep running in the Petrol mode

WARNING

Always replace blown fuse with a fuse of correct amperage. Never use a substitute like aliminum coil or wire to replace a blown fuse. When you replace a fuse and the new fuse also blows OFF instantly, have the car inspected at a TATA authorised service centre.

Fuses & Relays :

The electrical circuits in your car have fuses to protect the wiring from accidental short circuit or sustained overload. Fuses and relays are located at 3 locations in your car as shown in the sketch. Circuit connected through fuses and relays and the amperage of the fuse is printed on the fuse box covers.

Checking and replacing fuses :

If any electrical unit in your car has stopped functioning, the fuses should be checked first.

- Turn the ignition key to 'LOCK' position.
- Remove the fuse box cover, locate the fuse for the function.
- Remove the fuse & look for the fuse element inside the fuse. If it is damaged replace it with a fuse of same rating and type. Push the fuse firmly into the holder.
- Check that all other fuses are firmly in position and fix the cover back in position. Spare fuses are provided in the fuse box in the cabin.

If the replaced fuse of the correct rating burns out in short time, there is probably a serious electrical problem in your car. Get the car attended to at the nearest our Authorised Service outlet.

If any of the function relays is found defective, replace it by a genuine relay.

LOCATION OF FUSE BOX & RELAYS

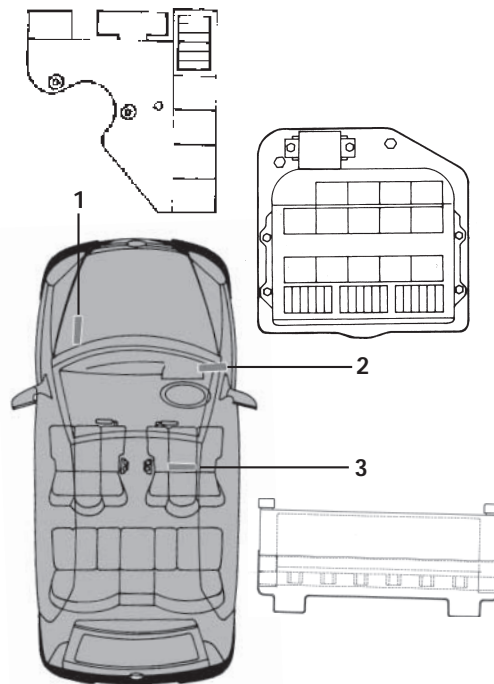

1. Engine compartment.
2. Cabin compartment under dashboard.
3. Cabin compartment under driver's seat (if installed).



Never use a fuse of higher rating than specified.
Always ensure that spare fuses are replenished.

Head Lamps :

The head lamps are provided with halogen lamps of H4 type with double filament for providing straight ahead illumination of the road for long distance or a dip beam which illuminates the road immediately ahead for short distance visibility. Use dip beam to avoid inconvenience / blinding the drivers of oncoming vehicles.

The head lamps must be properly aligned in order to obtain maximum road illumination and reduced glare for oncoming traffic. It is recommended to check alignment of head lamp beams periodically.

Focusing of Head Lamps & Front Fog Lamps :

Provision is made for focusing of head lamps and front fog lamps. This should be done at the Authorised Service outlets.

Head Lamp Bulb Replacement :

- Switch 'OFF' the head lamps & ensure that the bulb is not hot.
- Open the bonnet and remove the lamp connector from the head lamp bulb.
- Remove rubber cap. Unlock the locking clip and take out the bulb from the holder. This should be done carefully, otherwise it may lead to breakage of the bulb holder / holding clip.
- Note the instructions on the bulb carton.



Head Lamp

Fog Lamp

Replace the bulb with a new one of the same type with right orientation in the holder.

- Lock the clip, fit the rubber cap and fix the connector.
- Switch 'ON' the head lamps and check the lighting.

! Do not clean or touch the head lamp reflector as it will damage the mirror finish of the surface.

The horizontal and vertical adjustment screws are located on the back of the reflector.

Precise adjustment can be carried out only in the authorised workshops.

When replacing the head lamp bulb, handle it by gripping the cap. Protect the glass from contact with your skin or hard object. If you touch the glass, clean it with spirit & a clean cloth. After replacement of the bulb in any emergency get the head lamp adjustment done at an Authorised Service outlet at the earliest.

! Halogen head lamp bulbs get very hot when illuminated. Oil, perspiration or a scratch on the glass can cause the bulb to break due to the heat.



1. Head lamp bulb
2. Position lamp bulb
3. Rubber cap
4. Cable Assembly
5. Side Indicator bulb

CAR CARE :

The car is subjected to many external influences such as climate, road conditions, industrial pollution and proximity to the sea. These conditions demand regular care of the car body. Dirt, insects, bird droppings, oil, grease, fuel and stone chippings should be removed as soon as possible.

Washing :

Do not wash the car in direct sunlight, wash in shade. Spray the car thoroughly with a cold water jet (car on a washing pit or hoist). Mix car shampoo in the wash water. No solvent (fuel, thinners) need be used.

NOTICE

Avoid wiping of painted surface in dry condition as it may leave scratches on the painted surface.

Use a soft bristle brush, sponge or soft cloth and rinse it frequently while washing. When you have washed the whole exterior, dry it with a chamois or soft cloth. After drying the car, inspect it for chips and scratches that could allow corrosion to start. Apply touch up paint where necessary.

Polishes :

Polishes and cleaners can restore shine to the painted surface that has oxidised and become dull. They normally contain mild abrasives and solvents that remove the top layer

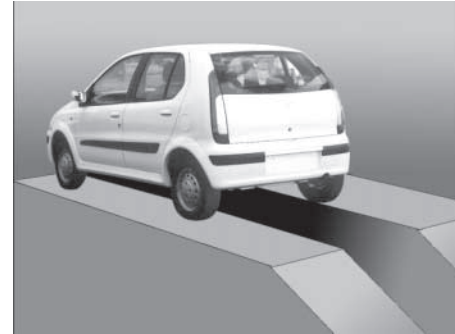

Car on Washing Pit

of the finish coat. Polish your car if the finish does not regain its original shine after using wax.

Cleaning of Carpets :

Vacuum clean the carpet regularly to remove dirt. Dirt will make the carpet wear out faster. Periodically shampoo the carpet to keep it looking new.

Use carpet cleaners (preferably foam type). Follow the instructions that come with the cleaner, applying it with a sponge or soft brush. Keep the carpeting as dry as possible by not adding water to the foam.

Cleaning of Windows, Front & Rear Glass :

Clean the windows inside and outside with commercially available glass cleaners.

This will remove the haze that builds up on the inside of windows. Use a soft cloth or paper towels to clean all glass and plastic surfaces.

Maintaining the car when not in extended use :

Park the car in covered, dry and if possible well-ventilated premises.

Engage a gear.

Remove the cables from the battery terminals (first remove the cable from the negative terminal).

Make sure the handbrake is not engaged.

Clean and protect the painted parts using protective wax.

Clean and protect the shiny metal parts using commercially available special compounds.

Sprinkle talcum powder on the rubber windscreen wiper and rear window wiper blades and lift them off the glass.

Slightly open the windows.

Cover the car with a cloth or perforated plastic sheet. Do not use sheets of imperforated plastic as they do not allow moisture on the car body to evaporate.

Inflate the tyres to 0.5 bar above the normal specified pressure and check it at regular intervals.

Check the battery charge every six weeks.

Do not drain the engine cooling system.

Wiper Care :

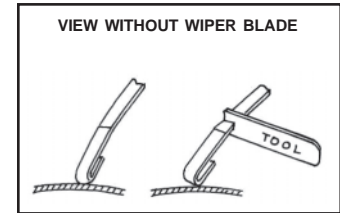
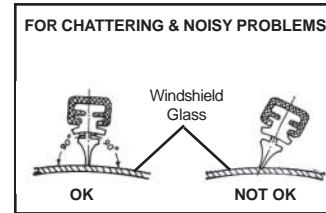

Wiper blade attack angle on windshield glass should be 90° i.e. perpendicular.

Remove wiper blade and root wiper arm on windshield glass in the centre position. Check the gap between arm strip and glass.

Adjust by twisting wiper arm as shown in the figure.

FOLLOWING GUIDELINES WILL HELP YOU TO BETTER PROTECT YOUR CAR FROM CORROSION

PROPER CLEANING :

In order to protect your car from corrosion it is recommended that you wash your car thoroughly and frequently in case :

1. There is an heavy accumulation of dirt and mud especially on the underbody.
2. It is driven in areas having high atmosphere pollution due to smoke, soot, dust, iron dust & other chemical pollutants.
3. It is driven in coastal areas.
4. The underbody must be thoroughly pressure washed after every three months.

In addition to regularly washing your car, the following precautions need to be taken.

PERIODIC INSPECTION :

1. Regularly inspect your car for any damage in the paint film such as deep scratches and immediately get them repaired from an Authorised Service Center, as these defects tend to accelerate corrosion.
2. Inspect mud liners for damages.
3. Keep all drain holes clear from clogging.

PROPER PARKING :

Always park your car in shade to protect it from harsh sunlight or in a well-ventilated garage so that there is no dampness on any part of the car.

WASHING YOUR CAR :

Follow these tips while washing your car.

HAND WASH :

1. Always wash your car in shade and when the surface is at room temperature.
2. Wash with mild car wash soap like "Car Shampoo" and use a soft 100% cotton cloth to avoid scratches. Please take help of your dealer to buy the right products.
3. Please be sure that you remove your wristwatch and wear soft gloves to avoid scratches due to finger rings or nails.
4. To remove stubborn stains and contaminants like tar, use turpentine or cleaners like "Stain Remover" which is safe for painted surfaces. Again your dealer can help you in selecting the right product.
5. Avoid substances like petrol, diesel, kerosene, benzene or other solvents that cause damage to paint.
6. Dry your vehicle thoroughly to prevent any damp spots.
7. Rinse all surfaces thoroughly to prevent any traces of soap and other cleaners as this may lead to the formation of stains on the painted surface later.

WAXING :

Waxing and polishing is recommended to maintain the gloss and wet-look appearance of your paint finish.

1. Use a good quality polish and wax for your car.
2. Re-wax your car when the water does not slip off the surface and collects over the surface in patches.

Further tips for the care of your new INDICA finish :

We recommend that you do not use an automatic car wash as the stiff brushes or sponges could mar the finish and damage the surface of your car. Wash the vehicle by hand with cool and clean water using a soft cloth or sponge. Please do not use soap but a car shampoo recommended by your dealer.

Please take the following precautions :

1. Always wash your car in shade, avoiding direct exposure to sunlight during washing.
2. Dry wiping your car may lead to the formation of scratches and hence always use a soft cloth and clean water while wiping your car.
3. Always keep your car parked in a well ventilated shade. Exposure to heat with entrapped moisture promotes corrosion.

4. Avoid driving on gravel roads, as the possibility of paint chip off due to the impact of stones is high. If you are driving on freshly tarred road, check immediately afterwards for any stains & clean them.
5. External contamination in the form of sap or industrial fall-out may mar or develop spots on a new finish. Hence avoid parking your car near trees, which are known to drop sap, or near factories, which give out heavy smoke.
6. The acid content in bird droppings may damage the newly painted finish and hence any bird dropping must be immediately washed off.
7. The paint finish is susceptible to damage in case petrol, brake fluid, liquid from car battery, oil, antifreeze, transmission fluid or windshield solvent spills onto the painted surface. In case of such a spillage immediately rinse the affected area with water. Avoid wiping the area far as possible, however if wiping is required, ensure that you wipe the area gently with soft cotton cloth.
8. Avoid using sharp objects to scrap off tar or mud from a painted surface as it may develop scratches or may peel off the paint.



EMERGENCY SERVICE TIPS

- ENGINE
- CLUTCH
- TRANSAXLE
- BRAKES
- STEERING SYSTEM
- ELECTRICAL
- SUSPENSION

EMERGENCY SERVICE TIPS

Engine

These tips are given for your guidance. These preliminary jobs are to be carried out in an emergency. In normal cases the problems should be attended to in an **Authorised Service outlet** by following the repair procedures given in the Workshop Manual.

SR. NO.	PROBLEM OBSERVED	PROBABLE CAUSE	ACTION TO BE TAKEN
ENGINE (LPG)			
1.	Engine not cranking	Dead battery, loose or improper battery/electrical connections	<ul style="list-style-type: none">• Get battery checked and/or changed• Jump start using another battery• Clean & tighten connections
		Engine stop solenoid fuse blown	<ul style="list-style-type: none">• Replace the fuse
2.	Engine overheats	Coolant level low, coolant leakages	<ul style="list-style-type: none">• Check and correct leakages• Top up coolant
		Hose collapsed/torn	<ul style="list-style-type: none">• Get the hose replaced
		Low engine oil level	<ul style="list-style-type: none">• Add oil
		Cap not sealing properly	<ul style="list-style-type: none">• Fit the auxiliary water tank cap correctly
		A.C. condenser fan not working	<ul style="list-style-type: none">• Get defect rectified
		Brakes binding	<ul style="list-style-type: none">• Get defect rectified
		Electric fan not working	<ul style="list-style-type: none">• Get defect rectified
		High delivery pressure in A.C. refrigerant circuit	<ul style="list-style-type: none">• Get defect rectified
		Radiator fins clogged	<ul style="list-style-type: none">• Clean it
		Radiator water passage clogged	<ul style="list-style-type: none">• Get it rectified
		Thermostat defective	<ul style="list-style-type: none">• Get it rectified

EMERGENCY SERVICE TIPS

Engine

SR. NO.	PROBLEM OBSERVED	PROBABLE CAUSE	ACTION TO BE TAKEN
3.	Poor pickup	Accelerator cable loose Air in the fuel system Clogged fuel filter Clogged air filter Clutch slipping/out of adjustment Brakes grabbing	<ul style="list-style-type: none">• Get it adjusted correctly• Remove the air• Clean / Replace the element• Clean / Replace the element• Get it rectified• Get it rectified
4.	Does not accelerate	Accelerator cable broken Fuel filter choked	<ul style="list-style-type: none">• Get cable replaced• Replace
5.	Belt squeal	Loose belt Belt glazed	<ul style="list-style-type: none">• Get belt tension adjusted• Get belt replaced
6.	Low engine oil pressure indicator 'ON' when engine is running even though engine oil level is within maximum/minimum marking	Pressure transducer faulty, and/or oil pump faulty	<ul style="list-style-type: none">• Do not run the engine extensively. Take the car to the nearest Authorised Service outlet & get the fault rectified
7.	Engine cranks but does not start - LPG Mode	No fuel LPG Fuel filter/Fuel lines choked Inertia Switch tripped safety solenoids not operating.	<ul style="list-style-type: none">• Get the unleaded fuel filled• Get the fuel filter replaced• Check fuse for fuel pump & EMS• Reset Inertia switch

EMERGENCY SERVICE TIPS

Engine, Clutch & Transaxle

SR. NO.	PROBLEM OBSERVED	PROBABLE CAUSE	ACTION TO BE TAKEN
8.	Check engine lamp continues to glow, even after start	Some faults are detected by the fuel injection & ignition system	<ul style="list-style-type: none"> • Get the vehicle checked and rectified at Authorised Workshop
CLUTCH			
1.	Clutch slipping	Improper pedal travel Rusted clutch cable Oil on clutch disc	<ul style="list-style-type: none"> • Adjust pedal travel • Replace cable • Clean or replace disc at Authorised Service outlet
2.	Noisy clutch	Pressure plate & diaphragm spring rattling Release bearing broken/worn out Broken damper spring of clutch disc	<ul style="list-style-type: none"> • Get car attended to by Authorised Service outlet • Replace • Replace
TRANSAXLE			
1.	Gears slipping out of mesh	Worn/damaged grooves on shifter shaft Worn shift fork or synchroniser sleeve Weak or damaged detent springs Worn bearings on input shaft or layshaft Worn dog teeth on sleeve and gear	<ul style="list-style-type: none"> • Replace • Replace • Replace • Replace • Replace sleeve and gear
2.	Hard shifting	Inadequate lubricant Inadequate clutch pedal travel Distorted or broken clutch disc	<ul style="list-style-type: none"> • Replenish • Adjust • Replace

SR. NO.	PROBLEM OBSERVED	PROBABLE CAUSE	ACTION TO BE TAKEN
3.	Noise	Damaged clutch pressure plate Worn synchrocones Worn dog teeth on sleeve or gear Distorted shift shaft/Linkages Inadequate or insufficient lubricant Damaged or worn bearing(s) Damaged or worn gear(s) Damaged or worn synchroniser parts	<ul style="list-style-type: none"> • Replace clutch cover/disc • Replace • Replace sleeve or gear • Replace • Replenish • Replace • Replace • Replace
BRAKES			
1.	Poor brakes	Insufficient brake fluid Air in the system Pedal travel excessive due to excessive shoe gap Vacuum leakage Brake oil (line) leaking Oil on the drum/liners Worn brake lining Defective/worn parts	<ul style="list-style-type: none"> • Get the brake fluid filled • Get the air removed • Rectify automatic adjuster • Rectify the leakage • Replace the leaking line • Get the liners cleaned/ Replace seals if leaking • Get the liners replaced • Get them replaced
2.	Brake pulling to one side	Oil on the brake lining One side shoe/pad worn Loose brake anchor plate	<ul style="list-style-type: none"> • Clean the brake lining • Get the shoe/pad replaced • Tighten the bolts

SR. NO.	PROBLEM OBSERVED	PROBABLE CAUSE	ACTION TO BE TAKEN
3.	Brake Squeal	One side brake pipe clogged Defective tandem master cylinder Defective brake lining Glazed lining Loose rivets. Wrong lining Shoe return spring broken Front pads rubbing on the disc	<ul style="list-style-type: none"> • Get the brake line cleaned • Rectify/Replace tandem master cylinder • Replace • Clean or replace lining • Install rivets properly • Install correct lining • Replace • Get it corrected

STEERING SYSTEM

1.	Hard steering (Mechanical)	Wheel alignment disturbed Rack & pinion need adjustment Low tyre pressure Grabbing of linkages	<ul style="list-style-type: none"> • Check & adjust • Check & replace if necessary • Adjust to correct value • Check & rectify
2.	Poor Returnability	Grabbing of linkages Steering gear disturbed	<ul style="list-style-type: none"> • Check & rectify • Check & adjust
3.	Excessive play in steering	Rack & pinion attachment loose	<ul style="list-style-type: none"> • Get it tightened
4.	Hard steering (For power steering)	Less fluid in the power steering tank Air in the system Loose pump belt Low tyre pressure	<ul style="list-style-type: none"> • Get the fluid topped up to the correct level • Get the air removed by bleeding the system • Get the belt correctly adjusted • Adjust to correct value

EMERGENCY SERVICE TIPS

Electrical/Suspension

SR. NO.	PROBLEM OBSERVED	PROBABLE CAUSE	ACTION TO BE TAKEN
ELECTRICAL			
1.	Battery charge & engine oil pressure lamp in cluster not operating when key is in 'IGN' position	Battery terminal loose or disconnected Battery completely dead Fuse blown Loose/open connections	<ul style="list-style-type: none">• Check connections• Get the battery properly connected• Get the battery charged• Get the alternator & charging circuit checked
2.	Non functioning electrical accessories such as power windows, head lamps, fuel & temperature gauge, RPM meter, wiper & washer unit and all lamps etc.	Fuse blown in the circuit Loose connectors. Circuit relay/controllers loose in the base Defective components	<ul style="list-style-type: none">• Replace the fuse if blown• Get the connection properly tightened/Fixed• Fix the relay firmly• Get the defective components replaced at an Authorised Service outlet
SUSPENSION			
1.	Abnormal or excessive tyre wear	Tyre out of balance Steering geometry disturbed Tyres not adequately inflated	<ul style="list-style-type: none">• Check balance and/or adjust if required• Adjust steering geometry• Adjust tyre pressure

SR. NO.	PROBLEM OBSERVED	PROBABLE CAUSE	ACTION TO BE TAKEN
2.	Abnormal noise from front end	Wobbly wheel or tyre Defective tyre Hub play not proper Brake grabbing Excessive braking	<ul style="list-style-type: none"> • Replace wheel or tyre • Replace tyre • Adjust hub play • Check and rectify • Modify driving habit
		Worn, sticky or loose tie rod ends, lower ball joints, tie rod in side ball joints or drive shaft joints	<ul style="list-style-type: none"> • Replace tie rod end, suspension arm, tie rod or drive shaft joints
		Warning noise for pad wear Damaged struts or mounting Worn suspension arm bushings Loose wheel nuts Loose suspension bolts or nuts Broken or damaged wheel bearing Poorly lubricated or worn strut bearings	<ul style="list-style-type: none"> • Replace pad • Repair mounting or replace struts • Replace • Tighten wheel nuts • Tighten suspension bolts or nuts • Replace • Lubricate or replace strut bearings
3.	Ride too soft / bumpy	Excessive hub play	<ul style="list-style-type: none"> • Adjust
4.	Suspension bottoms	Loose caliper housing bolts	<ul style="list-style-type: none"> • Check & tighten
		Faulty struts	<ul style="list-style-type: none"> • Replace strut
		Over loaded	<ul style="list-style-type: none"> • Check loading
		Faulty struts	<ul style="list-style-type: none"> • Replace struts



IMPORTANT INFORMATION

- **AGGREGATE NUMBERS**
- **FUEL, COOLANTS & LUBRICANTS**
- **TECHNICAL SPECIFICATIONS**
- **SERVICE SCHEDULE**
- **CAR RECORD SHEET**

LOCATION OF AGGREGATE NUMBERS

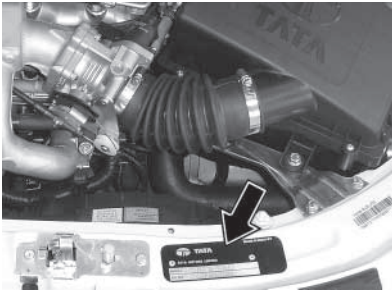

Chassis Number Plate

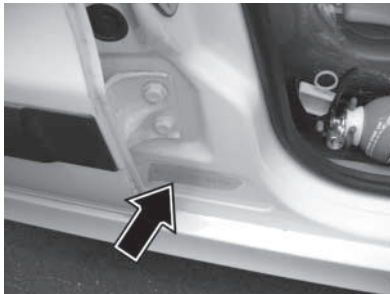

Chassis Number Plate

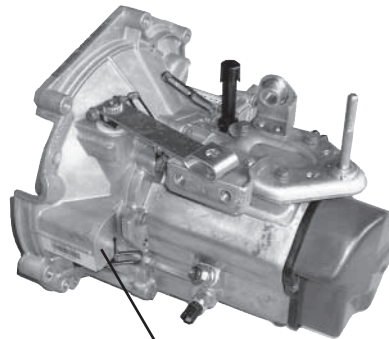

Transaxle Number

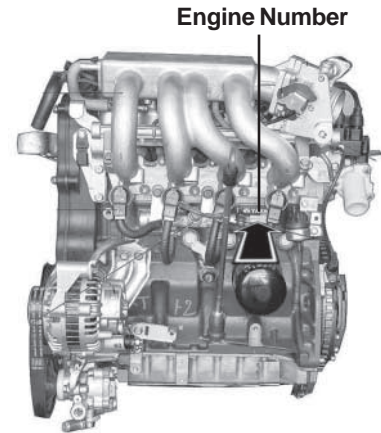

Engine Number

IMPORTANT INFORMATION

Fuel, Coolants & Lubricants

Fuel (BS- IV) :

Unleaded regular grade BS IV compliant petrol conforming to IS2796-1994/DIN 51607 (or equivalent) and RON not less than 91 is recommended to be used as fuel. It is always recommended to use BS IV Compliant petrol to get optimum emission performance.

Fuel (BS- III) :

Unleaded regular grade petrol conforming to IS2796-1994/ DIN 51607 (or equivalent) and RON not less than 87 is recommended to be used as fuel.



Do not use leaded petrol in a car fitted with catalytic converter. Even single fill of leaded petrol will seriously damage the catalytic converter.

Lubricants : (Petrol)

Engine oil : Recommended grade of engine oil conforming to API-SF/CC specification and range of ambient temperature at which these can be used are given in the table below.

Ambient temp. in deg. C	Engine oil grade
-10 deg. & above	SAE 20W/40 or SAE 20W/50
-15 deg. to 40 deg.	SAE 15W/40 or SAE 15W/50
-20 deg. to 40 deg.	SAE 10W/40 or SAE 10W/50
-35 deg. to 40 deg.	SAE 5W/30

Filler Neck

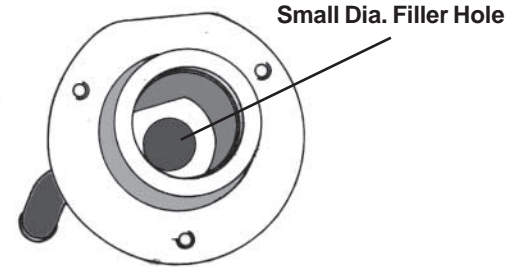

For Unleaded Petrol Version

Brand names :

As per chart given in the manual.

Transaxle :

Use recommended brand of EP 80 gear oil.

Grease for axle bearings :

Lithium base grease IPOL IPLEX LC Grease 2

Brake fluid :

IS 8654/DOT 3

Power Steering :

ATF –A DEXRON III

Coolants :

Presence of dirt in the coolant chokes up passages in the radiator, cylinder head and cylinder block, thereby causing insufficient cooling of engine.

To prevent rust formation and freezing of coolant inside the passages of radiator, cylinder block and cylinder head, use branded premixed coolant (ready to use).

IMPORTANT INFORMATION**Fuel, Lubricants & Coolants**

PLEASE USE ONLY GENUINE ENGINE OILS, COOLANTS, LUBRICANTS, ANTI RUST & SOUND DEADENING COATS, WINDSCREEN SEALANT, ADHESIVES & FUEL ADDITIVES BRANDED BY TATA MOTORS FOR OPTIMUM PERFORMANCE OF YOUR TATA INDICA LPG...

ITEM	COMPANY	BRAND	QTY
ENGINE OIL	CASTROL HPCL	Castrol GTX 20 W/40 HP ESMO 20 W/40	4.0 Litres
COOLANT	SUNSTAR HPCL	Golden Cruiser 1400 M HP Thanda Raja P	6 Litres
TRANSMISSION OIL	HPCL CASTROL	Gear Oil EP 80 Castrol Extreme Pressure 80 EP	3.3 Litres
STEERING OIL	HPCL CASTROL-TQDEX III EXXON	HP ATF - III Castrol TQ - III EXXON- Multipurpose ATF	1.2 Litres
BRAKE FLUID	HPCL CASTROL	Super Duty Brake Fluid DOT-3 Castrol Universal Brake Fluid DOT-3	0.265 Litres
HUB GREASE	CASTROL	Castrol Grease AP2	
ANTI RUST TREATMENT	DINITROL	Dinitrol	—
& SOUND DEADENING	WUERTH	Wuerth	—
WIND SCREEN SEALANT	ANCHEMCO	Terostat 8590 Kit Form	—
METAL & PLASTIC ADHESIVE	ANCHEMCO	Terostat 930	310 ml Cartridge

IMPORTANT INFORMATION

Technical Specifications

1. ENGINE

Model	: Bi-fuel (MPFI) TATA 475 SI"58
Type	: Water cooled, Bi-fuel (MPFI) Petrol Engine
No of cylinders	: 4 inline
Bore/Stroke	: 75 mm x 67.5 mm
Capacity	: 1193 cc
Max. engine output	: Petrol : 65 PS at 5000 rpm as per IS - 14599 LPG : 62 PS at 5000 rpm as per IS - 14599
Max. Torque	: Petrol : 102 Nm at 2600 rpm as per IS - 14599 LPG : 100 Nm at 2600 rpm as per IS - 14599
Compression ratio	: 10 : 1
Firing order	: 1-3-4-2

2. CLUTCH

Type	: Single plate dry friction diaphragm type
Outside diameter of clutch lining	: 190 mm
Friction area	: 285 sq.cm.

3. TRANSAXLE

	: Front wheel drive through constant velocity joints.
Model	: TA65-5 / 4.06 with overdrive
Type	: Synchromesh on all forward gears. Sliding mesh for reverse gear.
No. of gears	: 5 Forward, 1 Reverse
Gear ratios	: 1st - 3.64 2nd - 1.95 3rd - 1.27 4th - 0.88 5th - 0.714 Rev. - 3.58
Final drive ratio	: 4.06

IMPORTANT INFORMATION

- Gear Shift : Floor mounted with International "H" pattern, with Fifth and Reverse inline. with interlock to prevent accidental engagement from 5th to reverse
- 4. REAR AXLE** : Non driven axle Independently suspended
- 5. SUSPENSION**
- Front : Independent, Lower wishbone, McPherson Strut type.
- Rear : Independent, Semi-trailing arm with coil spring mounted on hydraulic shock absorbers.
- Antiroll bar : At front

Technical Specifications

6. STEERING

- GL / GLE Version : 1) Manual Rack & Pinion Steering Gear with collapsible steering column
- GLS / GLG Version : 2) Hydraulic Power assisted Rack & Pinion Steering Gear with collapsible steering column
- Steering Wheel : 380 mm dia

7. BRAKES

- Service brakes : Dual circuit, diagonal split hydraulic brakes through tandem master cylinder.
- Front : 231 mm dia disc brake
- Rear : 180 mm dia drum brake
- Parking brake : Lever type, Console mounted, Cable operated mechanical linkages acting on rear wheels

IMPORTANT INFORMATION

Technical Specifications

8. WHEELS & TYRES

Tyres	:	165/65 R13
Wheel rims	:	4.50 J x 13 stylised steel rims
No. of wheels	:	Front - 2 Rear - 2 Spare - 1

9. FUEL TANK

Capacity	:	37 litres (PETROL)
	:	31 litres (LPG)

10. BODY	:	Semi-mono Volume, Mini size 5 door hatch-back, steel monocoque body.
----------	---	--

11. ELECTRICAL SYSTEM

System Voltage	:	12 Volts -ve earth
Battery	:	12V, DIN 44
Alternator	:	12 V 90 Amps

12. PERFORMANCE

		(kmph)
Max. speed at rated :		140 (PETROL mode)
GVW		135 (LPG mode)

13. MAIN CHASSIS DIMENSIONS AS PER ISO:612 IN MM (Nominal) TOLERANCES AS PER INTEREUROPE STVZO

Wheel base	:	2400
Track front	:	1400
Track rear	:	1380
Front Overhang	:	785
Rear Overhang	:	490
Overall length	:	3675
Max. Width :		
Over body	:	1665
Over outer rear view mirrors in open condition:	:	1915
Overall height - unladen	:	1485
Min. turning circle dia	:	9.8 m
Min. turning clearance circle dia	:	10.2 m
Ground clearance - unladen	:	166

14. WEIGHT (kg) (TOLERANCE AS PER EEC 92/21)

Complete Vehicle	For GL	1045
kerb weight as per	For GLE	1060
ISO : 1176 (with	For GLS	1065
sparewheel and tools)	For GLG/GLX	1070

Gross vwhicle weight	For GL	1445
	For GLE	1460
	For GLS	1465
	For GLG/GLX	1470

Pay load	For all	400
----------	---------	-----

15. PASSENGER CAPACITY : 2 front + 3 rear

16. LUGGAGE SPACE

Net inside loading space	:	0.16 cubic metre
		upto rear seat backrest
		0.55 cubic metre
		upto front seat backrest
		when rear seat folded

IMPORTANT INFORMATION

Service Instructions

The Tata Indica has been manufactured to give you economical and trouble free performance. To achieve this please follow the instructions as stated.

Your Car is entitled to four free services (labour only). The free service coupons are attached to the sales invoice. Please present these coupons to the servicing dealer while availing free services.

- 1st free service** - At 1000-1500 km. OR 1 month whichever is earlier
- 2nd free service** - At 5000-5500km. OR 6 months whichever is earlier
- 3rd free service** - At 10000-10500km. OR 12 months whichever is earlier
- 4th free service** - At 20000-20500 km. OR 24 months whichever is earlier

All services other than free services are chargeable.

Service Schedule

Servicing of the car can be done at any TATA MOTORS Authorised Dealer Workshop, TATA MOTORS Authorised Service Centre (TASC) or TATA MOTORS Authorised Service Point (TASP). The details of their locations are given in this manual.

Warranty claims can be settled by any Tata Motors Authorised Dealer for all failures, while all warranty claims excluding the consideration on the replacement of major aggregates, can be settled by any TASC which is authorised for handling warranty claims. TASPs will not handle warranty repairs.

IMPORTANT INFORMATION

Service Schedule

	OPERATION	FREQUENCY	PDI	1,000 - 1,500	5,000 - 5,500	10,000 - 10,500	20,000 - 20,500	30,000 - 30,500	40,000 - 40,500	50,000 - 50,500	60,000 - 60,500	70,000 - 70,500	80,000 - 80,500	90,000 - 90,500	100,000 - 100,500
	ENGINE (LPG SYSTEM)														
1	LPG lines and joints (LPG leakage)	Every service	●	●	●	●	●	●	●	●	●	●	●	●	●
2	Clean the LPG filter First at 10000 km & thereafter at every 20000 km					●		●		●		●		●	
3	Replace the LPG filter / Cartridge paper	20000					●		●		●		●		●
4	Check safety solenoid valve on vaporiser	10000				●	●	●	●	●	●	●	●	●	●
5	Check pressure regulator for mountings, leakages, damages, proper functioning, Rectify if any	10000				●	●	●	●	●	●	●	●	●	●
6	Replace the pressure regulator diaphragm	40000							●				●		
7	LPG rail - check mountings, leakages -Rectify if any First at 10000 km & thereafter at every 20000 km					●		●		●		●		●	
8	Drain oil if any from regulator First at 10000 km & thereafter at every 20000 km					●		●		●		●		●	
9	Multifunction valve - Clean 'O' Ring & core Assy.	20000					●		●		●		●		●
10	Multifunction valve - Replace	100000													●
11	Check filler valve seals	100000													●

IMPORTANT INFORMATION

Service Schedule

	OPERATION	FREQUENCY	PDI	1,000 - 1,500	5,000 - 5,500	10,000 - 10,500	20,000 - 20,500	30,000 - 30,500	40,000 - 40,500	50,000 - 50,500	60,000 - 60,500	70,000 - 70,500	80,000 - 80,500	90,000 - 90,500	100,000 - 100,500
1	Wash the vehicle & Clean Condenser Fins	EVERY Service	•	•	•	•	•	•	•	•	•	•	•	•	•
2	Drain water accumulated in Sedimenter / when warning lamp glows (COMMON RAIL) Drain water from Fuel Filter Bowl (For Diesel Engines)	EVERY Service	•	•	•	•	•	•	•	•	•	•	•	•	•
3	Check & Top up Fluids (If required): Transaxle Oil, Coolant, Brake Fluid, Battery Electrolyte, Wind Screen washer fluid, Power Steering Oil (If fitted).	EVERY Service	•	•	•	•	•	•	•	•	•	•	•	•	•
4	Check Fuel Lines for Leakages.	10,000				•	•	•	•	•	•	•	•	•	•
5	Check Rubber Boots & Bushes for damage.	30,000						•			•			•	
	DIESEL / MPFI / COMMON RAIL ENGINE														
1	Clean air filter element (more frequently for vehicle operating as TAXI)	10,000			•	•	•	•	•	•	•	•	•	•	•
2	Change engine oil and Oil filter Or 12 Months whichever is earlier	10,000				•	•	•	•	•	•	•	•	•	•
3	Change fuel filter (MPFI) / fuel filter element (Diesel) Change fuel filter (COMMON RAIL)	10,000 30,000				•	•	•	•	•	•	•	•	•	•
4	Check all Drive belts for tension, adjust if necessary	10,000				•	•	•	•	•	•	•	•	•	•
5	Check timing belt, adjust tension if necessary, replace if defective (Diesel / MPFI)	20,000					•		•		•		•		•
6	Replace air filter element (more frequently for vehicle operating as TAXI)	40,000							•				•		
7	Change coolant (or two years whichever is earlier)	40,000							•				•		
8	Replace timing belt	100,000													•
9	Replace Spark Plugs (MPFI)	30,000						•			•			•	
10	Replace Sedimenter (COMMON RAIL)	100,000													•

IMPORTANT INFORMATION

Service Schedule

	OPERATION	FREQUENCY	PDI	1,000- 1,500	5,000- 5,500	10,000- 10,500	20,000- 20,500	30,000- 30,500	40,000- 40,500	50,000- 50,500	60,000- 60,500	70,000- 70,500	80,000- 80,500	90,000- 90,500	100,000-100,500
	TRANSAXLE														
1	Change Transaxle oil	20,000				•	•	•	•	•	•	•	•	•	•
	BRAKES														
1	Check front brake pads & rear brake linings. Replace if necessary	20,000				•	•	•	•	•	•	•	•	•	•
2	Repalce brake fluid (or 2 years whichever is earlier) & Check brake system components for Leakages	40,000							•				•		
	WHEELS & TYRES														
1	Rotate tyres	20,000				•	•	•	•	•	•	•	•	•	•
	FRONT & REAR SUSPENSION														
1	Check & Adjust Wheel alignment	20,000				•	•	•	•	•	•	•	•	•	•
	STEERING														
1	Replace power steering oil	80,000											•		
	ELECTRICAL														
1	Check specific gravity of battery electrolyte (OR Every 6 Months)	10,000			•	•	•	•	•	•	•	•	•	•	•
2	Check headlamp focussing	30,000					•			•				•	
	A.C. SYSTEM														
1	Check Airconditioning / HVAC System for satisfactory performance	EVERY Service	•	•	•	•	•	•	•	•	•	•	•	•	•

IMPORTANT INFORMATION**Service Schedule**

Date	Km. reading	Fuel filled	Fuel consumption	Remarks / Complaints

IMPORTANT INFORMATION**Service Schedule**

Date	Km. reading	Fuel filled	Fuel consumption	Remarks / Complaints

IMPORTANT INFORMATION

Recommended Service	Date	Odometer reading km.	Repair Order No.	Servicing Dealer's Signature & Stamp
At km.				
PDI Free Labour				
1,000 *				
10,000 *				
20,000 *				
30,000 *				
40,000				
50,000				
60,000				
70,000				
80,000				

Record of Services Performed

Recommended Service	Date	Odometer reading km.	Repair Order No.	Servicing Dealer's Signature & Stamp
At km.				
90,000				
1,00,000				
1,10,000				
1,20,000				
1,30,000				
1,40,000				
1,50,000				
1,60,000				
1,70,000				
1,80,000				

* Labour free, material chargeable

Record of Warranty repairs carried out

Chassis No. _____

Date	Odometer reading (km)	Repair Order No.	Particulars of Repair	Servicing Dealer's Signature & Stamp

Record of Warranty repairs carried out

Chassis No. _____

Date	Odometer reading (km)	Repair Order No.	Particulars of Repair	Servicing Dealer's Signature & Stamp