

**TRIPLE OUTPUT POWER SUPPLY
Agilent MODEL E3630A**

OPERATING AND SERVICE MANUAL



CERTIFICATION

Agilent Technologies certifies that this product met its published specifications at time of shipment from the factory. Agilent Technologies further certifies that its calibration measurements are traceable to the United States National Institute of Standards and Technology (formerly National Bureau of Standards), to the extent allowed by that organization's calibration facility, and to the calibration facilities of other International Standards Organization members.

WARRANTY

This Agilent Technologies hardware product is warranted against defects in material and workmanship for a period of 3 years from date of delivery. Agilent software and firmware products, which are designated by Agilent for use with a hardware product and when properly installed on that hardware product, are warranted not to fail to execute their programming instructions due to defects in material and workmanship for a period of 90 days from date of delivery. During the warranty period, either Agilent or Agilent Technologies will, at its option, either repair or replace products which prove to be defective. Agilent does not warrant that operation the software, firmware, or hardware shall be uninterrupted or error free.

For warranty service, with the exception of warranty options, this product must be returned to the nearest service center designated by Agilent. Customer shall prepay shipping charges by (and shall pay all duty and taxes) for products returned to Agilent for warranty service. Except for the products returned to Customer from another country, Agilent shall pay for return of products to Customer.

Warranty services outside the country of initial purchase are included in Agilent's product price, only if Customer pays Agilent international prices (defined as destination local currency price, or U.S. or Geneva Export price).

If Agilent is unable, within a reasonable time, to repair or replace any product to condition as warranted, the Customer shall be entitled to a refund of the purchase price upon return of the product to Agilent.

The warranty period begins on the date of delivery or on the date of installation if installed by Agilent.

LIMITATION OF WARRANTY

The foregoing warranty shall not apply to defects resulting from improper or inadequate maintenance by the Customer, Customer-supplied software or interfacing, unauthorized modification or misuse, operation outside of the environmental specifications for the product, or improper site preparation and maintenance. TO THE EXTENT ALLOWED BY LOCAL LAW, NO OTHER WARRANTY IS EXPRESSED OR IMPLIED. AND AGILENT SPECIFICALLY DISCLAIMS THE IMPLIED WARRANTIES OF MERCHANTABILITY AND FITNESS FOR A PARTICULAR PURPOSE.

For consumer transactions in Australia and New Zealand:

The warranty terms contained in this statement, except to the extent lawfully permitted, do not exclude, restrict or modify and are in addition to the mandatory rights applicable to the sale of this product to you.

EXCLUSIVE REMEDIES

TO THE EXTENT ALLOWED BY LOCAL LAW, THE REMEDIES PROVIDED HEREIN ARE THE CUSTOMER'S SOLE AND EXCLUSIVE REMEDIES. AGILENT SHALL NOT BE LIABLE FOR ANY DIRECT, INDIRECT, SPECIAL, INCIDENTAL, OR CONSEQUENTIAL DAMAGES, WHETHER BASED ON CONTRACT, TORT, OR ANY OTHER LEGAL THEORY.

ASSISTANCE

The above statements apply only to the standard product warranty. Warranty options, extended support contracts, product maintenance agreements and customer assistance agreements are also available. Contact your nearest Agilent Technologies Sales and Service office for further information on Agilent's full line of Support Programs.

SAFETY SUMMARY

The following general safety precautions must be observed during all phases of operation, service, and repair of this instrument. Failure to comply with these precautions or with specific warnings elsewhere in this manual violates safety standards of design, manufacture, and intended use of the instrument. Agilent Technologies assumes no liability for the customer's failure to comply with these requirements.

BEFORE APPLYING POWER.

Verify that the product is set to match the available line voltage and that the correct fuse is installed.

GROUND THE INSTRUMENT.

This product is a Safety Class I instrument (provided with a protective earth terminal). To minimize shock hazard, the instrument chassis and cabinet must be connected to an electrical ground. The instrument must be connected to the AC power supply mains through a three-conductor power cable, with the third wire firmly connected to an electrical ground(safety ground) at the power outlet. Any interruption of the protective(grounding) conductor or disconnection of the protective earth terminal will cause a potential shock hazard that could result in personal injury. If the instrument is to be energized via an external autotransformer for voltage reduction, be certain that the autotransformer common terminal is connected to the neutral(earthed pole) of the AC power lines (supply mains).

DO NOT OPERATE IN AN EXPLOSIVE ATMOSPHERE.

Do not operate the instrument in the presence of flammable gases or fumes.

KEEP AWAY FROM LIVE CIRCUITS.

Operating personnel must not remove instrument covers. Component replacement and internal adjustments must be made by qualified service personnel. Do not replace components with power cable connected. Under certain conditions, dangerous voltages may exist even with the power cable removed. To avoid injuries, always disconnect power, discharge circuits and remove external voltage sources before touching components.

DO NOT SERVICE OR ADJUST ALONE.

Do not attempt internal service or adjustment unless another person, capable of rendering first aid and resuscitation, is present.

SAFETY SYMBOLS



Caution, risk of danger (refer to this manual for specific Warning or Caution information)



Direct current (DC)



Alternating current (AC)



Protective conductor terminal



Out position of a bi-stable push control



In position of a bi-stable push control



Earth (ground) terminal



Positive binding post



Negative binding post



Frame or chassis terminal

WARNING

The WARNING sign denotes a hazard. It calls attention to a procedure, practice, or the like, which, if not correctly performed or adhered to, could result in personal injury. Do not proceed beyond a WARNING sign until the indicated conditions are fully understood and met.

CAUTION

The CAUTION sign denotes a hazard. It calls attention to an operating procedure, or the like, which, if not correctly performed or adhered to, could result in damage to or destruction of part or all of the product. Do not proceed beyond CAUTION sign until the indicated conditions are fully understood and met.

NOTE

The NOTE sign denotes important information. It calls attention to a procedure, practice, condition or the like, which is essential to highlight.

DO NOT SUBSTITUTE PARTS OR MODIFY INSTRUMENT.

Because of the danger of introducing additional hazards, do not install substitute parts or perform any unauthorized modification to the instrument. Return the instrument to a Agilent Technologies Sales and Service Office for service and repair to ensure that safety features are maintained.

Instruments that appear damaged or defective should be made inoperative and secured against unintended operation until they can be repaired by qualified service personnel.

REGULATORY MARKINGS



The CE marking is a legal compliance marking of the European Community. This CE marking shows that the product complies with all the relevant European Legal Directives.



The CSA mark is a registered trademark of the Canadian Standards Association.



The C-tick mark is a registered trademark of the Spectrum Management Agency of Australia. This signifies compliance with the Australia EMC Framework regulations under the terms of the Radio Communication Act of 1992.



This symbol indicates the time period during which no hazardous or toxic substance elements are expected to leak or deteriorate during normal use. Forty years is the expected useful life of the product.

ICES/NMB-001

ICES/NMB-001 indicates that this ISM device complies with the Canadian ICES-001. Cet appareil ISM est conforme a la norme NMB-001 du Canada.



This symbol is a South Korean Class A EMC Declaration. This is a Class A instrument suitable for professional use and in electromagnetic environment outside of the home.



This instrument complies with the WEEE Directive (2002/96/EC) marking requirement. This affixed product label indicates that you must not discard this electrical or electronic product in domestic household waste.

DECLARATION OF CONFORMITY

The Declaration of Conformity (DoC) for this instrument is available on the Agilent Web site. You can search the DoC by its product model or description at the web address below.

<http://regulations.corporate.agilent.com/DoC/search.htm>

NOTE

If you are unable to search for the respective DoC, please contact your local Agilent representative.

TABLE OF CONTENTS

SAFETY SUMMARY	1-3
REGULATORY MARKINGS	1-4
DECLARATION OF CONFORMITY	1-5
GENERAL INFORMATION	1-8
INTRODUCTION	1-8
SAFETY CONSIDERATIONS	1-8
SAFETY AND EMC REQUIREMENTS	1-8
INSTRUMENT AND MANUAL IDENTIFICATION	1-8
OPTIONS	1-8
ACCESSORY	1-8
DESCRIPTION	1-8
LINE FUSE	1-9
SPECIFICATIONS	1-9
INSTALLATION	1-10
INITIAL INSPECTION	1-10
Mechanical Check	1-10
Electrical Check	1-10
INSTALLATION DATA	1-10
Location and Cooling	1-10
Outline Diagram	1-10
Rack Mounting	1-10
INPUT POWER REQUIREMENTS	1-10
Power Cable	1-10
OPERATING INSTRUCTIONS	1-10
INTRODUCTION	1-10
TURN -ON CHECKOUT PROCEDURE	1-11
OPERATION	1-11
Tracking Ratio Control	1-11
Overload Protection Circuits	1-11
Operation Beyond Rated Output	1-11
Connecting Load	1-12
Parallel Operation	1-12
Series Operation	1-12
LOAD CONSIDERATIONS	1-12
PULSE LOADING	1-12
REVERSE CURRENT LOADING	1-12
OUTPUT CAPACITANCE	1-12
REVERSE VOLTAGE PROTECTION	1-12
SERVICE INFORMATION	A-1
MAINTENANCE	A-1
MAINTENANCE	A-1
INTRODUCTION	A-1
PERFORMANCE TESTS	A-2

GENERAL MEASUREMENT TECHNIQUES.....	A-2
TROUBLESHOOTING.....	A-6
ADJUSTMENT AND CALIBRATION.....	A-6
COMPONENT LOCATOR DIAGRAMS.....	A-7
MAIN BOARD — TOP.....	A-7
MAIN BOARD — BOTTOM.....	A-8
DISPLAY CONTROLLER — TOP.....	A-9
DISPLAY CONTROLLER — BOTTOM.....	A-10
7-SEGMENT — TOP.....	A-11
7-SEGMENT — BOTTOM.....	A-12

GENERAL INFORMATION

INTRODUCTION

This section contains general information concerning the E3630A triple output power supply. Included are safety considerations, safety and EMC requirements, instrument and manual identification, option and accessory information, instrument description, and specifications.

SAFETY CONSIDERATIONS

This product is a Safety Class I instrument, which means that it is provided with a protective earth ground terminal. This terminal must be connected to an AC source that has a 3-wire ground receptacle. Review the instrument rear panel and this manual for safety markings and instructions before operating the instrument. Refer to the Safety Summary page at the beginning of this manual for a summary of general safety information. Specific safety information is located at the appropriate places in this manual.

SAFETY AND EMC REQUIREMENTS

This power supply is designed to comply with the following safety and EMC(Electromagnetic Compatibility) requirements

Safety

- IEC 61010-1:2010 / EN 61010-1:2010
- CAN/CSA-C22.2 No. 61010.1-12

EMC

- IEC 61326-1:2005/EN61326-1:2006
- CISPR11:2003/EN55011:2007
- Canada: ICES/NMB-001:Issue 4, June 2006
Australia/New Zealand: AS/NZS CISPR 11:2004

INSTRUMENT AND MANUAL IDENTIFICATION

A serial number identifies your power supply. The serial number encodes the country of manufacture, the week of the latest significant design change, and a unique sequential number. The letter "KR" or "MY" designates Korea or Malaysia as the country of manufacture respectively. For Korea the first one digit indicates the year (3=1993, 4=1994, and so forth), and the second two digits indicate the week. For Malaysia, the first two digits indicate Agilent year and the second two digits indicate the work-week. The remaining digits of the serial number are a unique, five-digit number (Korea) or four-digit number (Malaysia) assigned sequentially.

If a yellow Change Sheet is supplied with this manual, its purpose is to explain any differences between your instrument and the instrument described in this manual.

The Change Sheet may also contain information for correcting errors in the manual.

OPTIONS

Options OEM, OE3, and OE9 determine which line voltage is selected at the factory. The standard unit is configured for 115 VAC \pm 10%, 47-63 Hz input.

Option No.	Description
OEM:	115 VAC \pm 10%, 47-63 Hz Input
OE3:	230 VAC \pm 10%, 47-63 Hz Input
OE9:	100 VAC \pm 10%, 47-63 Hz Input

ACCESSORY

The accessory listed below may be ordered from your local Agilent Technologies Sales Office either with the power supply or separately. (Refer to the list at the rear of the manual for address.)

Agilent Part No.Description

5063-9767	Rack Kit for mounting one or two 3 1/2" high supplies in a standard 19" rack
-----------	--

The rack mount kit is needed for rack mounting of the E3630A power supply.

DESCRIPTION

This constant-voltage/current-limiting triple output power supply combines two 0 to \pm 20 V tracking outputs rated at 0.5 amps with an additional single output that is rated at 0 to 6 volts and 2.5 amps. The +20 V and -20 V tracking outputs can also be used in series as a single 0 to 40 V 0.5-amp output. Connections to the supply's output and to chassis ground are made to binding posts on the front panel. The supply's three outputs share a common output terminal, which is isolated from chassis ground so that any one output terminal can be grounded.

All outputs are protected against overload and short-circuit damage. The \pm 20 V outputs are protected by circuits that limit the output current to 110% of its nominal maximum. The overload protection circuit for the +6 V output has a current fold-back characteristic that reduces the output current as an overload increases until only 1 amp flows through a short circuit. The 6 V output current limit depends on the output terminal voltage and varies linearly between 2.75 amps at 6 volts and 1 amp at zero volts.

All controls, digital meter, and output terminals are located on the front panel. One voltage control sets the 0 to 6 V and another sets the voltages of the 0 to +20 V and 0 to -20 V outputs simultaneously. These dual tracking outputs are made more versatile by providing a tracking ratio control in addition to the usual voltage control. With the tracking ratio control turned fully clockwise to its "fixed" position, the dual outputs have a fixed 1:1 tracking ratio. As the \pm 20V voltage control is adjusted, the voltage of the negative supply tracks the positive output within \pm 1%. Turning the tracking ratio control away from its fully clockwise position switches the dual tracking outputs into a variable tracking ratio mode. In this mode the voltage of the negative output can be set lower than that of the positive output. The tracking ratio control allows the negative supply's output to be set to any value between a maximum that is within \pm 5% of the positive supply's output and a minimum that is less than 0.5 volts.

Once a ratio is established by the tracking ratio control, the ratio of the positive output voltage to the negative output voltage remains constant as the \pm 20 V voltage control varies the 0 to +20 V output over its range.

The front panel also contains a line switch, three overload indicators for +6 V output, +20 V output, and -20 V output, a voltmeter and an ammeter, and three push-button meter switches. The push buttons select one of the supply's three outputs for display. The voltmeter and ammeter always monitor any one supply simultaneously. In addition to the standard 115 VAC \pm 10% 47 to 63 Hz input, two other line voltage options are available for nominal inputs of 100 and 230 Vac. The supply is furnished with a detachable 3-wire grounding type line cord. The AC line fuse is in an extractor type fuseholder on the rear heat sink.

LINE FUSE

The line fuse is located by the AC line receptacle. Check the rating of the line fuse and replace it with the correct fuse if necessary as indicated below. These are slow-blow fuses.

Line Voltage	Fuse	Agilent Part No.
100/115 VAC	1.6 A	2110-0918
230 VAC	1.0 A	2110-0599

SPECIFICATIONS

Table 1 lists detailed specifications for the power supply.

Table 1. Specifications

WARRANTED SPECIFICATIONS	HUMIDITY
<p>DC OUTPUT and OVERLOAD PROTECTION</p> <p><u>0 to \pm20 V Outputs:</u> Maximum rated output current is 0.5 A. Short circuit output current is 0.55 A \pm 5% and a fixed current limit circuit limits the output of each supply to this maximum at any output voltage setting. Unbalanced loads within current rating are permitted.</p> <p><u>0 to +6 V Output:</u> Maximum rated output current is 2.5 A at 6 V. The maximum available output current decreases with the output voltage setting. A current foldback circuit limits the output to 2.75 A \pm 5% at 6 volts and, with decreasing voltage, reduces the current limit linearly to 1 A \pm 15% at zero volts (short circuited).</p> <p>LOAD REGULATION</p> <p><u>All Outputs:</u> Less than 0.01% plus 2 mV for a full load to no load change in output current.</p> <p>LINE REGULATION</p> <p><u>All Outputs:</u> Less than 0.01% plus 2 mV for any line voltage change within rating.</p> <p>TRACKING ACCURACY</p> <p>The +20 V and -20 V outputs track within 1% with the TRACKING ratio control in the Fixed position. (In variable tracking ratio mode, the negative tracking output can be adjusted from less than 0.5 V to within \pm5% of the setting of the positive output.)</p> <p>PARD (Ripple and Noise)</p> <p><u>All Outputs:</u> Less than 0.35 mV rms/1.5 mV p-p (20 Hz-20 MHz).</p> <p><u>Common Mode Current (CMI):</u> Less than 1 μA for all outputs (20 Hz-20 MHz).</p> <p>OPERATING TEMPERATURE RANGE</p> <p>0 to 40 °C for full rated output. At higher temperatures, output current is derated linearly to 50% at 55 °C maximum temperature.</p> <p>OPERATING ALTITUDE</p> <p>Up to 2000 m</p> <p>STORAGE TEMPERATURE RANGE</p> <p>-20 °C to 70 °C</p>	<p>Up to 80% RH</p> <p>LOAD TRANSIENT RESPONSE TIME</p> <p><u>All Outputs:</u> Less than 50 μsec for output recovery to within 15 mV of nominal output voltage following a load change from full load to half load, or vice versa.</p> <p>METER ACCURACY: \pm(0.5% of output + 2 counts) at 25 °C \pm5 °C</p> <p>METER RESOLUTION</p> <p><u>All Output:</u> <u>Voltage</u> 10 mV <u>Current</u> 10 mA</p> <p>TYPICAL (SUPPLEMENTAL) SPECIFICATIONS</p> <p>TEMPERATURE COEFFICIENT</p> <p><u>All Outputs:</u> Less than 0.02% plus 1 mV voltage change per °C over the operating range from 0 to 40 °C after 30 minutes warm-up.</p> <p>STABILITY (OUTPUT DRIFT)</p> <p><u>All Outputs:</u> Less than 0.1% plus 5 mV (DC to 20 Hz) during 8 hours at constant line, load and ambient after an initial warm-up time of 30 minutes.</p> <p>OUTPUT VOLTAGE OVERSHOOT</p> <p><u>All Outputs:</u> During turn-on or turn-off of AC power, output plus overshoot will not exceed 1 V if the output control is set for less than 1 V. If the control is set for 1 V or higher, there is no overshoot.</p> <p>GENERAL SPECIFICATIONS</p> <p>AC INPUT</p> <p><u>OEM:</u> 115 VAC \pm 10%, 47-63 Hz, 115 VA, 84 W</p> <p><u>OE9:</u> 100 VAC \pm 10%, 47-63 Hz, 115 VA, 84 W</p> <p><u>OE3:</u> 230 VAC \pm 10%, 47-63 Hz, 115 VA, 84 W</p> <p>DIMENSIONS</p> <p>212.3 mmW x 88.1 mmH x 269.2 mmD (8.354 inW x 3.469 inH x 10.591 inD)</p> <p>WEIGHT: 3.8 kg(8.4 lbs) net, 5.1 kg(11.3 lbs) shipping</p> <p>This instrument is Intended for Indoor use.</p>

INSTALLATION

INITIAL INSPECTION

Before shipment, this instrument was inspected and found to be free of mechanical and electrical defects. As soon as the instrument is unpacked, inspect for any damage that may have occurred in transit. Save all packing materials until the inspection is completed. If damage is found, a claim should be filed with the carrier. The Agilent Technologies Sales and Service office should be notified as soon as possible.

Mechanical Check

This check should confirm that there are no broken knobs or connectors, that the cabinet and panel surfaces are free of dents and scratches, and that the meter is not scratched or cracked.

Electrical Check

Perform the TURN-ON CHECKOUT PROCEDURE in the following paragraph to confirm that the supply is operational. Alternately, check the supply more fully using the PERFORMANCE TEST in the service information section.

INSTALLATION DATA

The instrument is shipped ready for bench operation. Before applying power to the supply, please read the INPUT POWER REQUIREMENTS paragraph.

Location and Cooling

This instrument is air cooled. Sufficient space should be allowed so that a free flow of cooling air can reach the sides and rear of the instrument when it is in operation. It should be used in an area where the ambient temperature does not exceed 40 °C.

Outline Diagram

Figure 1 illustrates the outline shape and dimensions of the supply.

Rack Mounting

This supply may be rack mounted in a standard 19-inch rack panel either by itself or alongside a similar unit. Please see the ACCESSORY, page 1-8, for available rack mounting accessory. The rack-mounting kit includes complete installation instructions.

INPUT POWER REQUIREMENTS

Depending on the line voltage option ordered, the supply is ready to be operated from one of the power sources listed in Table 1. A label on the rear heat sink shows the nominal input voltage set for the supply at the factory.

Power Cable

To protect operating personnel, the supply should be grounded. This supply is equipped with a three conductor power cable. The third conductor is the ground conductor and when the cable is plugged into an appropriate receptacle, the supply is grounded.

The power supply is equipped at the factory with a power

cord plug appropriate for the user's location. Notify the nearest Agilent Sales and Service Office if the appropriate power cord is not included with the supply.

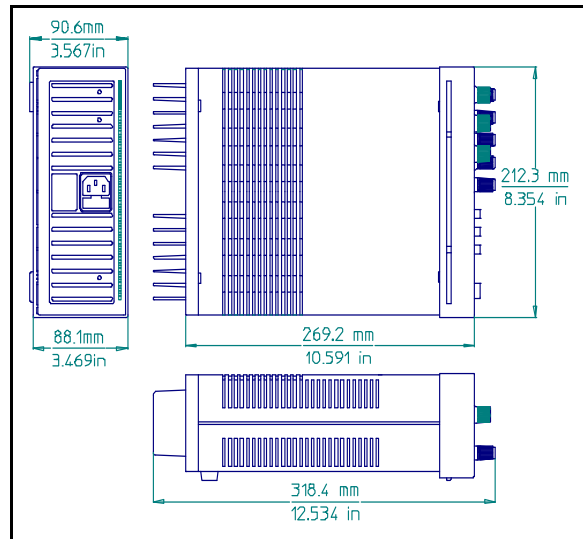

Figure 1. Outline Diagram

OPERATING INSTRUCTIONS

INTRODUCTION

The following steps describe the use of the front panel controls and indicators illustrated in Figure 2 and serve as a brief check that the supply is operational. Follow this checkout procedure or the more detailed performance test of service information section when the instrument is received and before it is connected to any load equipment.

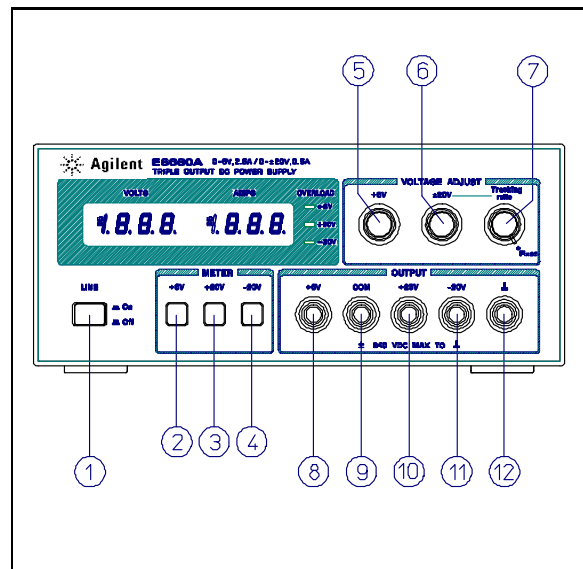

Figure 2. Front-Panel Controls and Indicators

CAUTION

Before applying power to the supply, check the label on the heat sink to make certain that the supply's line voltage option agrees with the line voltage to be used. If the option does not correspond to your line voltage, refer to paragraph "LINE VOLTAGE OPTION CONVERSION" in the service section before applying power.

TURN -ON CHECKOUT PROCEDURE

- a. Connect line cord to power source and turn LINE switch ① on.
- b. Push +6V METER switch ② and, with no load connected, vary +6 V VOLTAGE control ⑤ over its range and check that the voltmeter responds to the control setting and the ammeter indicates zero.
- c. Set the +6V VOLTAGE control to 6 volts and short the +6 V output terminal ⑧ to COM (common) terminal ⑨ with an insulated test lead. The ammeter should indicate a short-circuit output current of approximately 1.0 A. Remove the short from the output terminals.
- d. Push the +20 V METER switch ③ and turn Tracking Ratio control ⑦ fully clockwise to the Fixed position. With no load connected, vary ± 20 V VOLTAGE control ⑥ over its range and check that the voltmeter responds to the control setting and the ammeter indicates zero.
- e. Set the ± 20 V VOLTAGE control ⑥ to 20 volts and short the +20 V output terminal ⑩ to the COM terminal ⑨ with an insulated test lead. The ammeter should indicate a short-circuit output current of $0.55 \text{ A} \pm 5\%$. Remove the short from the output terminals.
- f. Repeat steps (d) and (e) for -20 V output.
- g. Adjust the +20 V output to 20 volts. Then push -20 V METER switch and check the effect of the Tracking Ratio control on the voltage of the -20 V output. The -20 V output should be adjustable from less than 0.5 volts to a maximum of 19 to 21 volts.

If this brief checkout procedure or later use of the supply reveals a possible malfunction, see the service information section for detailed test, troubleshooting, and adjustment procedures.

OPERATION

This power supply can be operated individually or in parallel or series with another supply (see Parallel and Series Operation paragraphs). All output terminals are isolated from ground. The ± 20 V and +6 V outputs use a single common output terminal. This common (COM) terminal or any one of the other output terminals may be grounded to the chassis at the front panel ground terminal (⑫ in Figure 2), or all outputs may be left floating. Loads can be connected separately between each of the 0 to ± 20 V output terminals and the COM terminal, or between the -20 V and the +20 V terminals for a 0 to 40 V output. Each output voltage or current can be quickly selected for monitoring with the push-button meter switches.

To monitor the 0 to 40 V output voltage, add the voltmeter readings of the +20 V and -20 V output and use either the +20 V or the -20 V meter to measure the current.

Tracking Ratio Control

With the Tracking Ratio control in the Fixed position, the voltage of the -20 V supply tracks that of the +20 V supply within 1% for convenience in varying the symmetrical voltages needed by operational amplifiers and other circuits using balanced positive and negative inputs.

Turn the Tracking Ratio control counter clockwise out of the Fixed position to set the voltage of the -20V supply lower than that of the +20 V supply. The negative supply can be set from a minimum of less than 0.5 volts to a maximum within 5% of the +20 V supply's output. Once this is done, the ± 20 V voltage control still controls both outputs and maintains a constant ratio between their voltages.

Overload Protection Circuits

± 20 -Volt Current Limit. The +20 V and -20 V outputs are individually protected against overload or short circuit damage by separate current limit circuits to limit the output current to $0.55 \text{ A} \pm 5\%$. (This is 110% of the maximum rated output.) If a single load is connected between the +20 V and -20 V outputs, the circuit set for the lesser current limit will limit the output. No deterioration of supply performance occurs if the output current remains below the current limit setting.

+6V Current Foldback. The overload and short-circuit protection circuit for the +6 V output reduces the output current limit as the output terminal voltage decreases. (The operating region of the +6 V output is enclosed by heavy lines in Figure 4.) The maximum rated output current is 2.5 A and the current limit is factory-adjusted to operate at $2.75 \text{ A} \pm 5\%$ when the output is 6 volts. At lower output voltages, the circuit reduces the maximum obtainable output current linearly until $1 \text{ A} \pm 15\%$ flows when the output is shorted. The short-circuit current cannot be adjusted.

NOTE

During the actual operation of the ± 20 V and +6 V outputs, if a load change causes the current limit to be exceeded, the OL LED is lighted. If overload conditions occur, the ± 20 V supplies will protect the load by limiting the current to 0.55 A and the +6 V supply will protect the load by reducing both voltage and current simultaneously along the foldback locus as shown in Figure 4. The ± 20 V and +6 V supplies are self restoring; that is, when the overload is removed or corrected, the output voltage is automatically restored to the previously set value.

Operation Beyond Rated Output

The supply may be able to provide voltages and currents greater than its rated maximum outputs if the line voltage is at or above its nominal value. Operation can be extended up to 5% over the rated output without damage to the supply, but performance cannot be guaranteed to meet specifications in

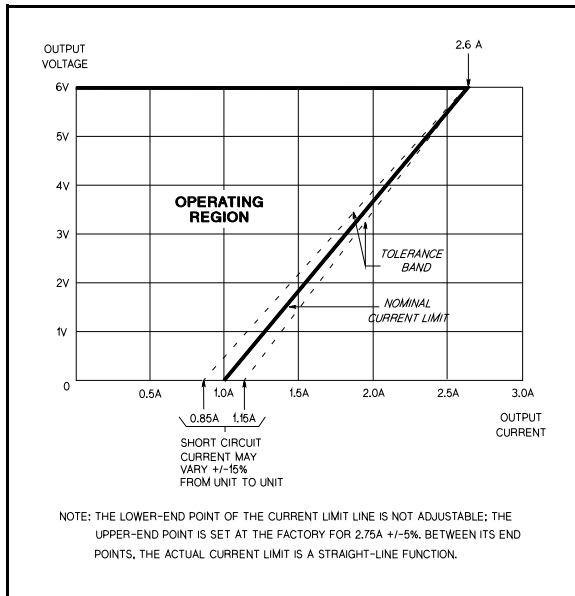

Figure 3. Current Limit Characteristic of the 6V Supply

this region. If the line voltage is maintained in the upper end of the input voltage range, however, the supply probably will operate within its specifications

Connecting Load

Each load should be connected to the power supply output terminals using separate pairs of connecting wires. This will minimize mutual coupling effects between loads and takes full advantage of the low output impedance of the supply. Load wires must be of adequately heavy gauge to maintain satisfactory regulation at the load.

Each pair of connecting wires should be as short as possible and twisted or shielded to reduce noise pick-up. If a shield is used, connect one end to the supply ground terminal and leave the other end unconnected.

If load considerations require locating output power distribution terminals at a distance from the power supply, then the power supply output terminals should be connected to the remote distribution terminals by a pair of twisted or shielded wires and each load should be connected to the remote distribution terminals separately.

Parallel Operation

Two or more supplies can be connected in parallel to obtain a total output current greater than that available from one supply. The total output current is the sum of the output currents of the individual supplies. The output voltage controls of one power supply should be set to the desired output voltage, and the other supply set for a slightly larger output voltage. The supply set to the lower output voltage will act as a constant voltage source, while the supply set to the higher output will act as a current-limited source, dropping its output voltage until it equals that of the other supply. The constant voltage source will deliver only that fraction of its rated output current

necessary to fulfill the total current demand.

Series Operation

Series operation of two or more power supplies can be accomplished up to the output isolation rating of any one supply to obtain a higher voltage than that available from a single supply. Series connected supplies can be operated with one load across both supplies or with a separate load for each supply. The power supply has a reverse polarity diode connected across the output terminals so that if operated in series with other supplies, damage will not occur if the load is short-circuited or if one supply is turned on separately from its series partners. When this connection is used, the output voltage is the sum of the voltages of the individual supplies. Each of the individual supplies must be adjusted in order to obtain the total output voltage.

LOAD CONSIDERATIONS

This section provides information on operating your supply with various types of loads connected to its output.

PULSE LOADING

The power supply will automatically cross over from constant-voltage to current-limit operation in response to an increase in the output current over the preset limit. Although the preset limit may be set higher than the average output current, high peak currents (as occur in pulse loading) may exceed the preset current limit and cause crossover to occur and degrade performance.

REVERSE CURRENT LOADING

An active load connected to the supply may actually deliver a reverse current to the supply during a portion of its operating cycle. An external source cannot be allowed to pump current into the supply without risking loss of regulation and possible damage to the output capacitor of the supply. To avoid these effects, it is necessary to preload the supply with a dummy load resistor so that the supply delivers current through the entire operating cycle of the load devices.

OUTPUT CAPACITANCE

An internal capacitor across the output terminals of the supply helps to supply high-current pulses of short duration during constant-voltage operation. Any capacitance added externally will improve the pulse current capability, but will decrease the load protection provided by the current limiting circuit. A high-current pulse may damage load components before the average output current is large enough to cause the current limiting circuit to operate.

REVERSE VOLTAGE PROTECTION

A diode is connected across the output terminals with reverse polarity. This diode protects the output electrolytic capacitors and the series regulator transistors from the effects of a reverse voltage applied across the output terminals. Since series regulator transistors cannot withstand reverse voltage either, diodes are also connected across them. When operating supplies in parallel, these diodes protect an unenergized supply that is in parallel with an energized supply.

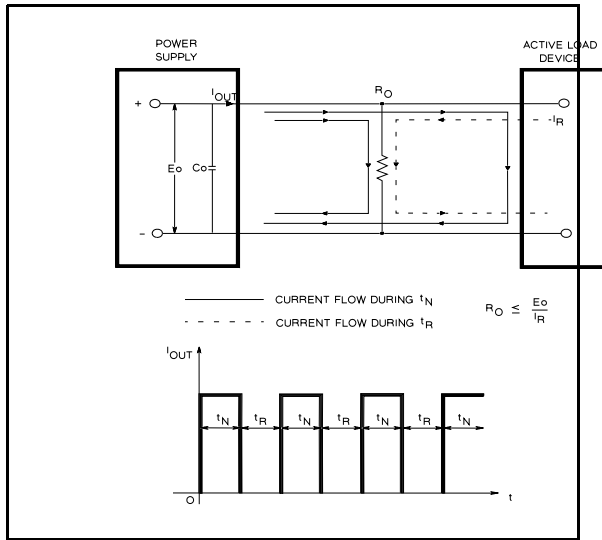

Figure 4. Reverse Current Loading Solution

THIS PAGE HAS BEEN INTENTIONALLY LEFT BLANK.

SERVICE INFORMATION

MAINTENANCE

INTRODUCTION

This section provides performance test, troubleshooting information, and adjustment and calibration procedures. The following operation verification tests comprise a short procedure to verify that the power supply is performing properly, without testing all specified parameters.

If a fault is detected in the power supply while making the performance check or during normal operation, proceed to

the troubleshooting procedures. After troubleshooting, perform any necessary adjustments and calibrations. Before returning the power supply to normal operation, repeat the performance check to ensure that the fault has been properly corrected and that no other faults exist.

Test Equipment Required

The following Table A-1 lists the equipment required to perform the various procedures described in this section.

Table A-1. Test Equipment Required

TYPE	REQUIRED CHARACTERISTICS	USE	RECOMMENDED MODEL
Oscilloscope	Sensitivity : 100 μ V Bandwidth : 20 MHz/100 MHz	Display transient response and ripple and noise waveforms.	Agilent 54600A
RMS Voltmeter	True rms, 20 MHz bandwidth Sensitivity : 1 mV Accuracy : 5%	Measure rms ripple and noise voltage.	
Multimeter	Resolution : 100 nV Accuracy : 0.0035%	Measure DC voltages.	Agilent 34401A
Electronic Load	Voltage Range : 240 VDC Current Range : 10 ADC Open and short switches Transient on/off	Measure load and line regulation.	Agilent 6063A
Resistive Loads (R_L)	40 Ω 20 W, 2.4 Ω 20 W	Measure ripple and noise.	
Current Sampling Resistor (Shunt)	100 m Ω 0.1% 15 W	Measure output current	
Variable Voltage Auto Transformer	Range : 85-130 and 200-260 Volts	Vary AC input.	

Operation Verification Tests

The following tests assure that the power supply is performing properly. They do not, however, check all the specified parameters tested in the complete performance test described below. Proceed as follows:

- Perform turn-on checkout procedure given in page 1-11.
- Perform the load regulation performance tests given in the following paragraphs.

Line Voltage Option Conversion

To convert the supply from one line voltage option to another, the following three steps are necessary:

- After making certain that the line cord is disconnected from a source of power, remove the top cover from the supply and set the two sections of the line voltage selector switch for the desired line voltage (see Figure A-1).
- Check the rating of the installed fuse and replace it with the correct value, if necessary. For Option OE3, use a slow-blow 1.0-amp fuse. For standard and Option OE9, use a slow-blow 1.6-amp fuse.

- Mark the instrument clearly with a tag or label indicating the correct line voltage to be used.

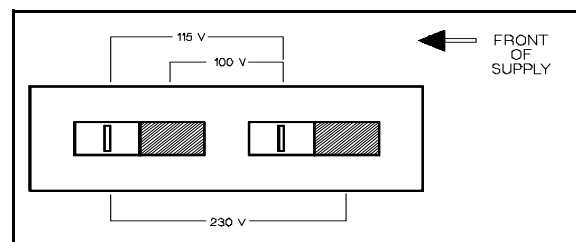

Figure A-1. Line Voltage Selector (set for 115 VAC)

PERFORMANCE TESTS

The following paragraphs provide test procedures for verifying the power supply's compliance with the specifications of Table 1. Proceed to the troubleshooting procedures if you observe any out of specification performance.

CAUTION

Before applying power to the supply, make certain that its line voltage selector switch (S2) is set for the line voltage to be used. (See CAUTION notice in operating section for additional information on S2.)

GENERAL MEASUREMENT TECHNIQUES

Connecting Measuring Devices. To achieve valid results when measuring load regulation, ripple and noise, and transient response time of the supply, measuring devices must be connected as close to the output terminals as possible. A measurement made across the load includes the impedance of the leads to the load. The impedance of the load leads can easily be several orders of the magnitude greater than the supply impedance and thus invalidate the measurement. To avoid mutual coupling effects, each measuring device must be connected directly to the output terminals by separate pairs of leads.

When performance measurements are made at the front terminals (Figure A-2) the load should be plugged into the front of the terminals at (B) while the monitoring device is connected to a small lead or bus wire inserted through the hole in the neck of the binding post at (A). Connecting the measuring device at (B) would result in a measurement that includes the resistance of the leads between the output terminals and the point of connection.

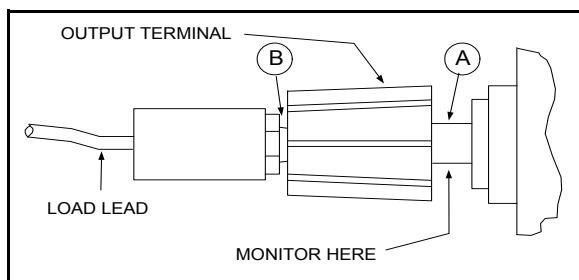

Figure A-2. Front Panel Terminal Connections

Selecting Load Resistors. Power supply specifications are checked with a full load resistance connected across the supply output. The resistance and wattage of the load resistor, therefore, must permit operation of the supply at its rated output voltage and current. For example, a supply rated at 20 volts and 0.5 amperes would require a load resistance of 40 Ω at the rated output voltage. The wattage rating of this resistor would have to be at least 20 watts.

Electronic Load. Some of the performance test procedures use an electronic load to test the supply quickly and accurately. An electronic load is considerably easier to use than a

load resistor. It eliminates the need for connecting resistors or rheostats in parallel to handle the power, it is much more stable than a carbon-pile load. It is easier to switch between load conditions as required for the load regulation and load transient response tests.

Output Current Measurement. For accurate output current measurements, a current sampling resistor should be inserted between the load and the output of the supply. To simplify grounding problems, one end of this sampling resistor should be connected to the same output terminal of the supply which will be shorted to ground. An accurate voltmeter is then placed across the sampling resistor and the output current calculated by dividing the voltage across the sampling resistor by its ohmic value. The total resistance of the series combination should be equal to the full load resistance as determined in the preceding paragraphs. Of course, if the value of the sampling resistor is very low when compared to the full load resistance, the value of the sampling resistor may be ignored. The meter shunt recommended in Table A-1, for example, has a resistance of only 100 m Ω and can be neglected when calculating the load resistance of the supply. Figure A-3 shows a four terminal meter shunt. The load current through a shunt must be fed from the extremes of the wire leading to the resistor while the sampling connections are made as close as possible to the resistance portion itself.

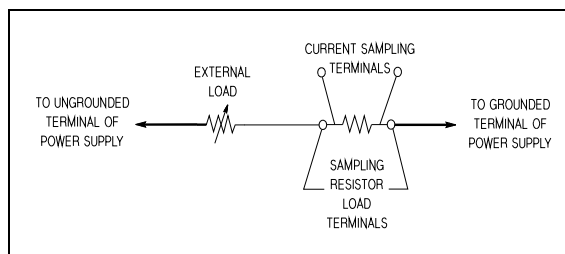

Figure A-3. Current Sampling Resistor Connections

Rated Output, Tracking, Meter Accuracy, and Current Limit

To check that all supplies will furnish their maximum rated output voltage and current, that the ± 20 V outputs track each other, that the front panel meters are accurate, and that the current limit circuits function, proceed as follows:

Voltmeter Accuracy (+6V)

- With no loads connected: turn on the supply, connect a digital voltmeter between the +6V terminal and common (COM), and set the +6V VOLTAGE control so that the DVM indication is as near as possible to 5 volts.
- Push the +6V METER switch on and check the front panel voltmeter indication. It should be within $\pm(0.5\% + 2 \text{ counts})$ of the DVM indication (4.96 V to 5.04 V).

Voltmeter Accuracy (± 20 V)

- With no loads connected: turn on the supply, connect a digital voltmeter between the +20 V terminal and common (COM), and set the ± 20 V VOLTAGE control so that the DVM indication is as near as possible to 17 volts.
- Push the +20V METER switch on and check the front panel voltmeter indication. It should be within $\pm(0.5\% + 2 \text{ counts})$ of the DVM indication (16.90 V to 17.10 V).

- c. Set the TRACKING RATIO control to the FIXED position, and check the +20 V and -20 V ranges of the front panel voltmeter similarly by connecting the DVM to each of these outputs in turn, setting the ± 20 V VOLTAGE control for a 20 volts DVM indication, and verifying that the panel meter is accurate within $\pm(0.5\%+2 \text{ counts})$ (19.7 V to 20.3 V).

Tracking

- d. Connect the DVM to the +20 V output, set the ± 20 V VOLTAGE control for a DVM indication of 20 volts, and reconnect the DVM to the -20 V output without disturbing the voltage control. The voltage at the -20 V output should be within 1% of the +20 V output (19.8 V to 20.2 V).

Variable Tracking Ratio

- e. Leave the ± 20 V VOLTAGE control set as in step (d), and use a DVM to monitor the voltage of the -20 V supply while adjusting the TRACKING RATIO control over its VARIABLE range. The -20 V supply should be capable of being adjusted from less than 0.5 volts to between 19 to 21 volts. Return the TRACKING RATIO control to the FIXED position.

NOTE

Leave the TRACKING RATIO control in the FIXED position throughout the rest of the performance test.

Rated Output and Ammeter Accuracy

- f. Connect two 40 Ω 20 W load resistors across both of the 20V outputs of the supply and set the ± 20 V VOLTAGE control for ± 20 V outputs. (All supplies must be fully loaded while checking the rated output voltage and current of each supply.)
- g. Connect the test setup shown Figure A-4 to the +6 V output. Make the total resistance of R_L and the current sampling resistor equal to 2.4 Ω to permit operating the output at full load. R_L should have a power rating of at least 20 watts.
- h. Close the switch and set the +6 V VOLTAGE control so that the DVM indicates a voltage drop across the current sampling resistor that corresponds to a current of 2.5 amps.
- i. Push the +6 V METER switch and verify that the front panel ammeter indication is within $\pm(0.5\%+2 \text{ counts})$ of 2.5 amps (2.47 A to 2.53 A).
- j. Check the rated output and ammeter accuracy of the +20 V and -20 V supplies similarly by connecting the test setup of Figure A-4 to each output in turn. For each 20 V supply: make the total resistance of R_L and the current sampling resistor 40 Ω , set the ± 20 V VOLTAGE control for a current indication on the DVM of 0.5 A, check that the panel meter indication is within $\pm(0.5\%+2 \text{ counts})$ of 0.5 A (0.48 A to 0.52 A).

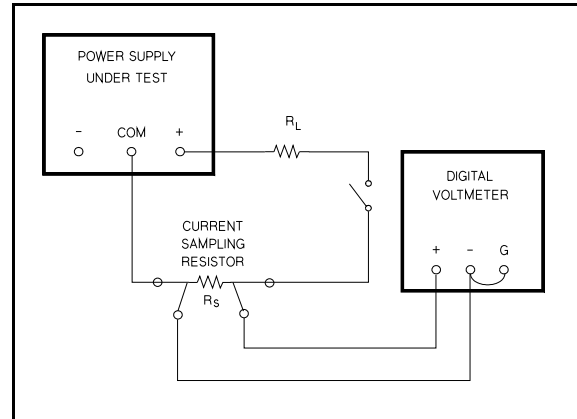

Figure A-4. Output Current, Test Set UP

Current Limit

- k. Disconnect all loads from the supply.
- l. Connect the test setup shown in Figure A-4 to the +20-volt output. Substitute a short for R_L and leave the load circuit switch open.
- m. Set the voltage of the ± 20 V supplies to 20 volts.
- n. Close the load switch and determine the current flow through the current sampling resistor (meter shunt) by measuring its voltage drop with the DVM. The current should be 0.55 A $\pm 5\%$ (0.5225 A to 0.5775 A).
- o. Check the current limit of the -20 V supply in the same way. Its short-circuit current should also be 0.55 A $\pm 5\%$ (0.5225 A to 0.5775 A).
- p. Connect the test setup shown in Figure A-4 to the +6V output. Close the switch, set the total resistance of R_L and the current sampling resistor to an initial value of 2.4 Ω or greater, and set the output voltage to 6 volts.
- q. Reduce the value of R_L gradually while observing the output current indicated by the DVM. The current should increase to a maximum of 2.75 A $\pm 5\%$ (2.6125 A to 2.8875 A) before it begins to decrease.
- r. Connect a short across R_L and then recheck the current indicated by the DVM. The short-circuit current of this output should be 1 A $\pm 15\%$ (0.85 A to 1.15 A). Disconnect the test setup from the supply.

Load Regulation (Load Effect)

Definition: The immediate change, $\bullet E_{OUT}$, in the static value of DC output voltage resulting from a change in load resistance from open circuit to the value that yields maximum rated output current (or vice versa).

To check the load regulation:

- a. Connect the test equipment across the output of the +20 V supply as shown in Figure A-5. Operate the electronic load in constant current mode and set its current to the full rated value of the +20 V supply. Input off the electronic load.
- b. Turn on the supply and adjust its voltage to its maximum rated value. Then input on the electronic load.
- c. Record the voltage indicated on the DVM.

- d. Operate the electronic load in open (input off) mode and recheck the DVM indication immediately. The readings' difference during the immediate change should be within 0.01% plus 2 mV of the reading in step (c).
- e. Repeat steps (a) through (d) for each of the remaining supply outputs.

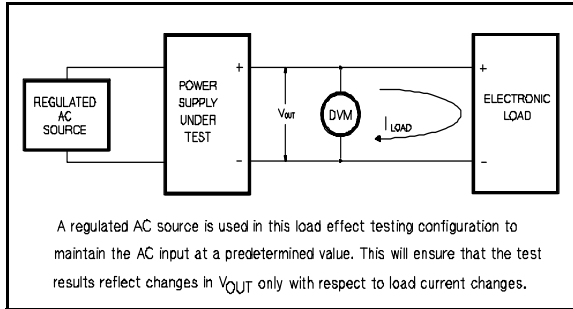

Figure A-5. Basic Test Setup

Line Regulation (Source Effect)

Definition: The immediate change, E_{OUT} , in the static value of DC output voltage resulting from a change in AC input voltage from a minimum to a maximum value ($\pm 10\%$ of nominal voltage).

To check the line regulation:

- a. Connect a variable autotransformer between the input power source and the power supply line plug.
- b. Connect the test equipment across the output of the +20 V supply as shown in Figure A-5. Operate the electronic load in constant current mode and set its current to the full rated value of the +20 V supply. Input off the electronic load.
- c. Adjust the autotransformer for a low line input (-10% of nominal voltage).
- d. Turn on the power, adjust the output of the supply to its maximum rated voltage, then input on the electronic load. Record the DVM indication.
- e. Adjust the autotransformer for high line voltage input ($+10\%$ of nominal voltage) and recheck the DVM indication immediately. The readings' difference during the immediate change should be within 0.01% plus 2mV of the reading in step (d).
- f. Repeat steps (b) through (e) for each of the remaining supply outputs.

Ripple and Noise

Definition: Ripple and noise are measured in the rms or peak-to-peak value over a 20 Hz to 20 MHz bandwidth. Fluctuations below the lower frequency limit are treated as drift.

RMS Measurement

The rms measurement is not an ideal representation of the noise, since fairly high output noise spikes of short duration could be present in the ripple and not appreciably increase the rms value.

To measure the ripple and noise of the rms value on each output supply output:

- a. Connect the test equipment across the output of the +20 V supply as shown in Figure A-6.
- b. Turn on the supply and push +20V METER switch.

- c. Turn up output voltage to the full rated value.
- d. Check that the rms noise voltage at the true rms voltmeter is less than 0.35 mV.
- e. Repeat for the remaining supply outputs.

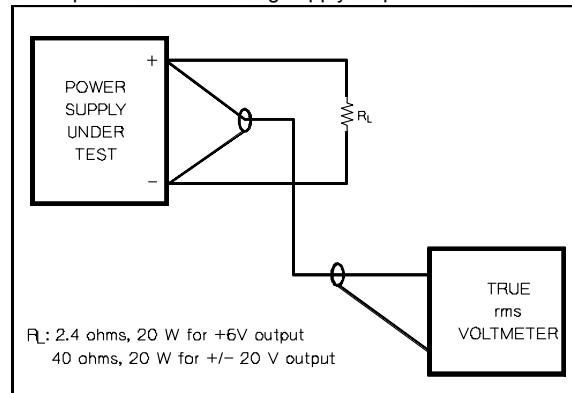

Figure A-6. Ripple and Noise rms Measurement Test Setup

Peak-to-Peak Measurement

The peak-to-peak measurement is particularly important for applications where noise spikes could be detrimental to a sensitive load, such as logic circuitry.

To measure the ripple and noise of the peak-to-peak value on each output supply output:

- a. Connect the test equipment across the output of the +20 V supply as shown in Figure A-6, but replace the true rms voltmeter with the oscilloscope.
- b. Turn on the supply and push +20 V METER switch.
- c. Turn up output voltage to the full rated value.
- d. Set the oscilloscope to AC mode and bandwidth to 20 MHz.
- e. Check that the peak-to-peak noise is less than 1.5 mV.
- f. Repeat for the remaining supply outputs.

Common Mode Current (CMI)

Definition : Common mode current is that AC current component which exists between any or all supply or output lines and chassis ground.

To measure the common mode current:

- a. Connect the full load for +6 V output.
- b. Connect a 100 k Ω resistor(R_S) and a 2200 pF capacitor in parallel between common terminal(COM) and chassis ground.
- c. Connect the DVM across R_S .
- d. Turn on the supply.
- e. Record the voltage across R_S and convert it to current by dividing this voltage by R_S .
- f. Check that the current is less than 1 μ A.

Load Transient Response Time

Definition : This is the time for the output voltage to return to within a specified band around its voltage following a change from full load to half load or half load to full load.

To measure the load transient response time:

- Connect the test equipment across the output of the +20 V supply as shown in Figure A-5, but replace the DVM with the oscilloscope. Operate the electronic load in constant current mode.
- Turn on the supply.
- Turn up output voltage to the full rated value.

- Set the electronic load to transient operation mode between one half of supply's full rated value and supply's full rated value at a 1 KHz rate with 50% duty cycle.
- Set the oscilloscope for AC coupling, internal sync and lock on either the positive or negative load transient.
- Adjust the oscilloscope to display transients as in Figure A-7.
- Check that the pulse width (t_2-t_1) of the transients at 15 mV from the base line is no more than 50 μ sec as shown.
- Repeat for the remaining supply outputs.

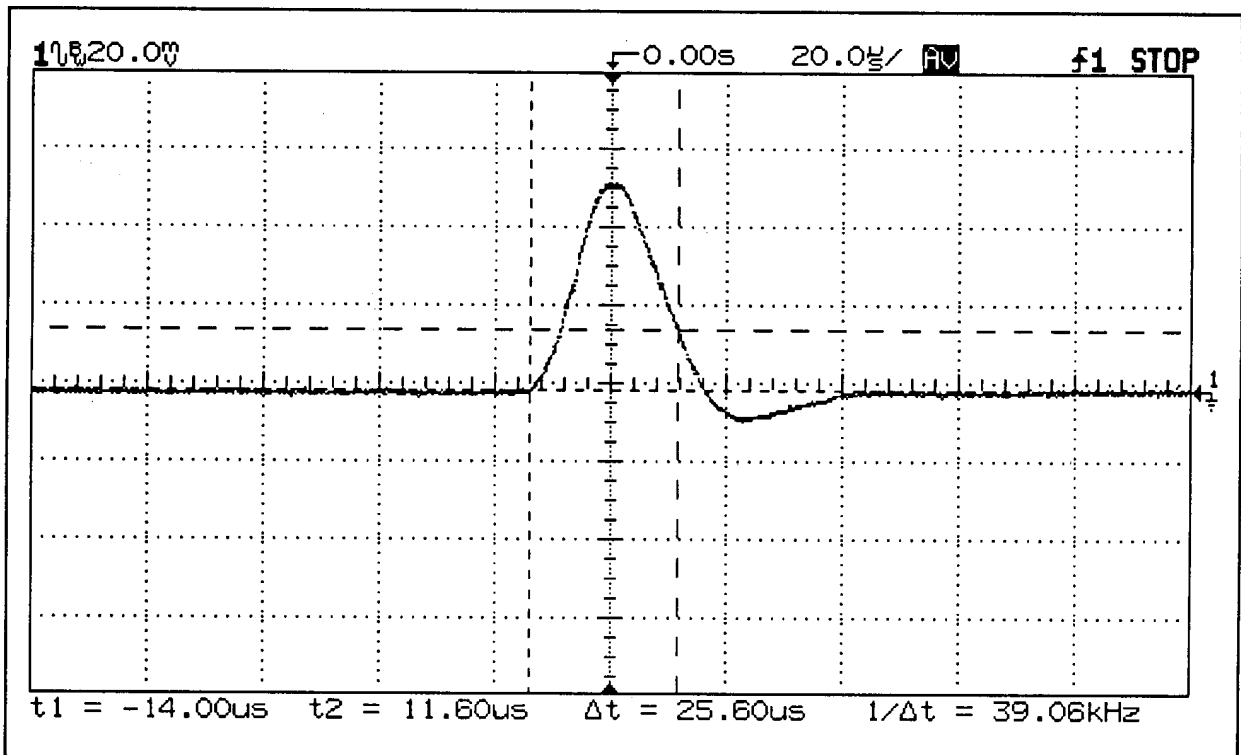

Figure A-7. Load Transient Response Time Waveform

Stability (Drift)

Definition: The change in output voltage (DC to 20 Hz) for the first 8 hours following a 30-minute warm-up period with constant input line voltage, constant load resistance and constant ambient temperature.

To measure the stability:

- Connect the test equipment across the output of the +20 V supply as shown in Figure A-5.
- Operate the electronic load in constant current mode and set its current to the full rated value of power supply.
- Turn on the supply.
- Turn up output voltage to the full rated value as read on the digital voltmeter.
- After a 30-minute warm-up, note the voltage on DVM.

- The output voltage reading should deviate less than 0.1% plus 5 mV from the reading obtained in step e over a period of 8 hours.
- Repeat for the remaining supply outputs.

TROUBLESHOOTING

Before attempting to troubleshoot the power supply, ensure that the fault is with the supply and not with an associated piece of equipment. You can determine this without removing the covers from the power supply by using the appropriate portions of the "Performance Test" paragraph.

CAUTION

Before applying power to the supply, make certain that its line voltage selector switch (S2) is set for the line voltage to be used.

Open Fuse Troubleshooting

Although transients or fatigue can cause a fuse to blow, it is a good idea to inspect the unit for obvious shorts such as damaged wiring, charred components, or extraneous metal parts or wire clippings in contact with circuit board conductors before replacing the fuse. The rating of the correct replacement fuse depends on the line voltage option of the instrument: for Option OE3, use a slow-blow 1.0-amp fuse and standard and Option OE9, use a slow-blow 1.6-amp fuse.

ADJUSTMENT AND CALIBRATION

Current Limit Adjustment

+6 V Supply. To adjust the current limit circuit in the +6 V supply, proceed as follows:

- Check the setting of the current limit by performing steps (p) and (q) on page A-3. (Be sure to set the output voltage to 6 volts.) If reducing the load resistance permits the current to exceed 2.9 A, stop, turn R6 slightly clockwise, and repeat the test. If, instead, the current begins to fall before it reaches 2.6 A, turn R6 slightly counter clockwise and repeat the test.
- Recheck the setting and readjust R6 until the test shows that the current limit circuit begins to reduce the current when a decreasing load resistance increases it to 2.75 A \pm 5%.

Meter Calibration

Panel Voltmeters. To calibrate voltmeter, proceed as follows:

- Connect DVM across +20 V output terminal and COM terminal of the supply.
- Turn on the supply.
- Set the output voltage below 18 V (ex, 15 V), and adjust R11 on the display board until front panel VOLTS display reads exactly DVM value. Next, set the output voltage above 20 V (ex, 21 V) and adjust R17 on the display board until front panel VOLTS display reads exactly DVM value.

NOTE

No other voltage output needs to be calibrated after calibrating the voltmeter of +20V output.

Panel Ammeter. To calibrate ammeter for +20 V output and -20 V output, proceed as follows:

- Connect R_S between +20 V output terminal and COM terminal and connect DVM across R_S .
- Push +20 V meter switch and turn ± 20 V VOLTAGE control fully clockwise.
- Turn on the supply and adjust R5 on the display board until front panel AMPS display reads exactly DVM value divided by R_S .
- To calibrate the ammeter for +6 V output, select +6 V meter switch and turn +6 V VOLTAGE control fully clockwise.
- Adjust R61 on the main board until front panel AMPS display reads exactly DVM value divided by R_S .

COMPONENT LOCATOR DIAGRAMS

MAIN BOARD — TOP

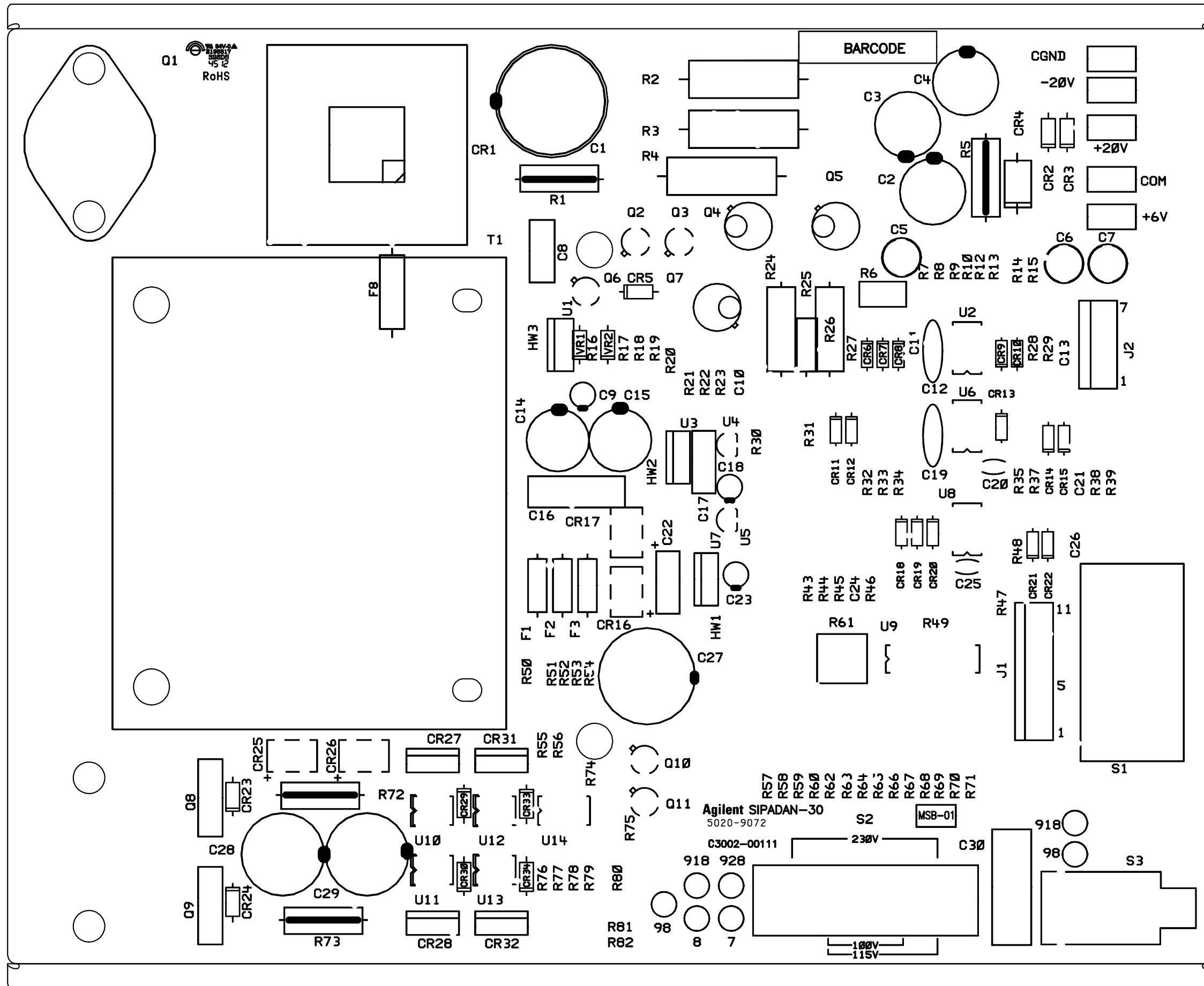

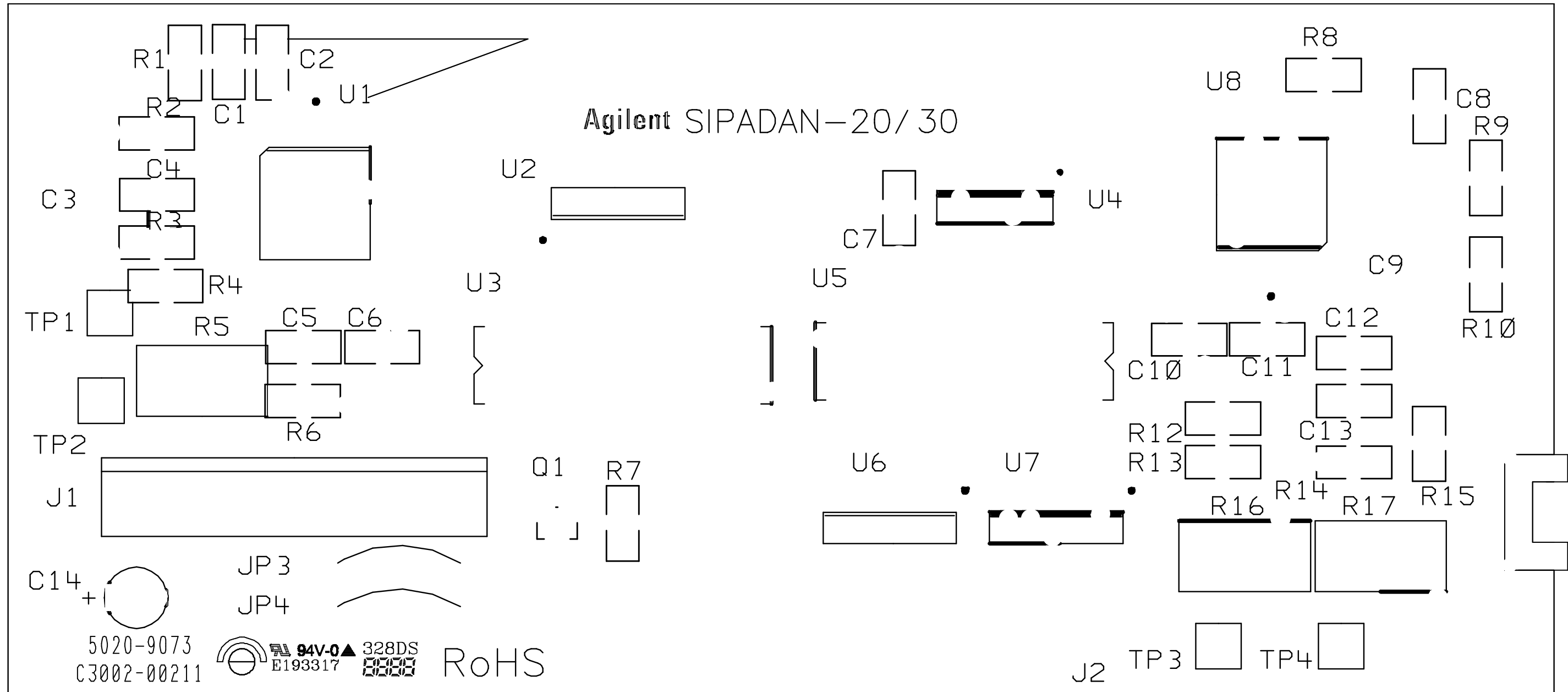

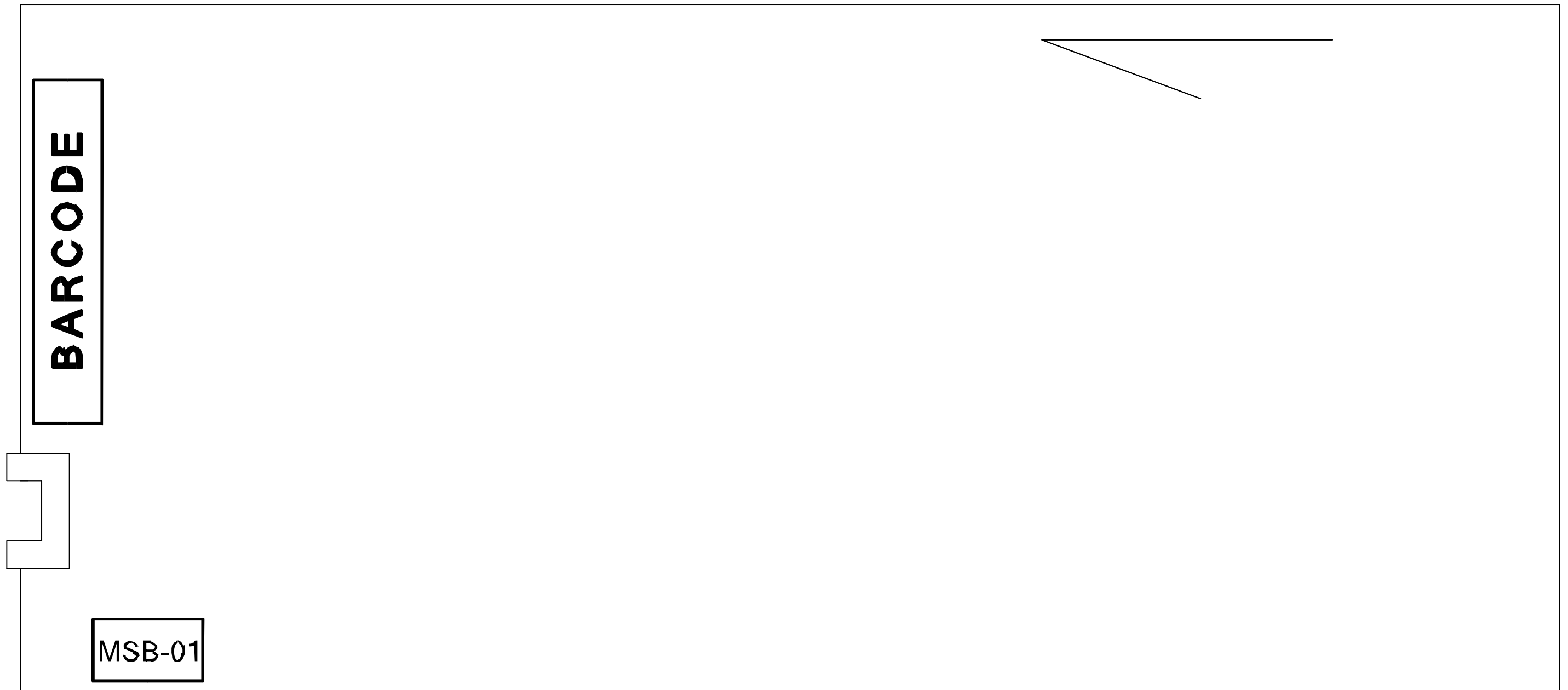

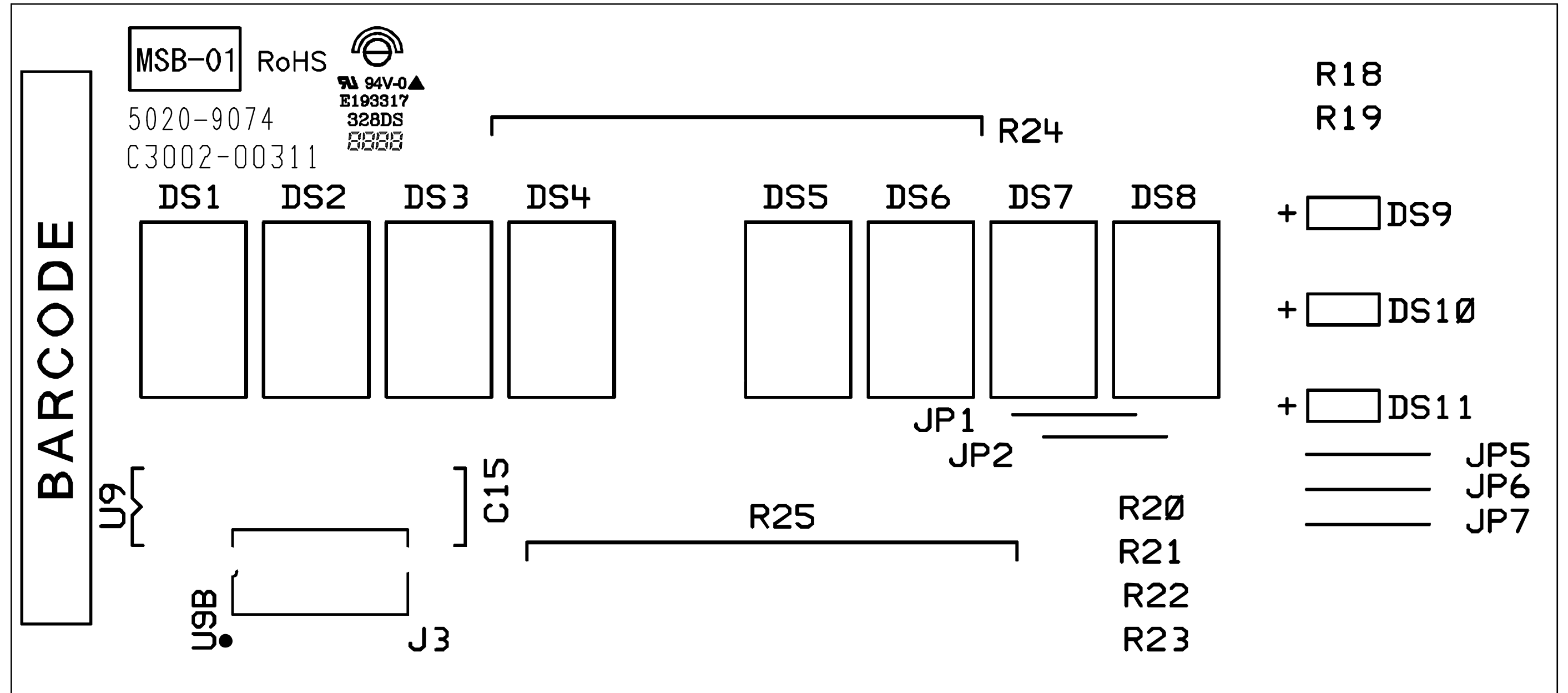

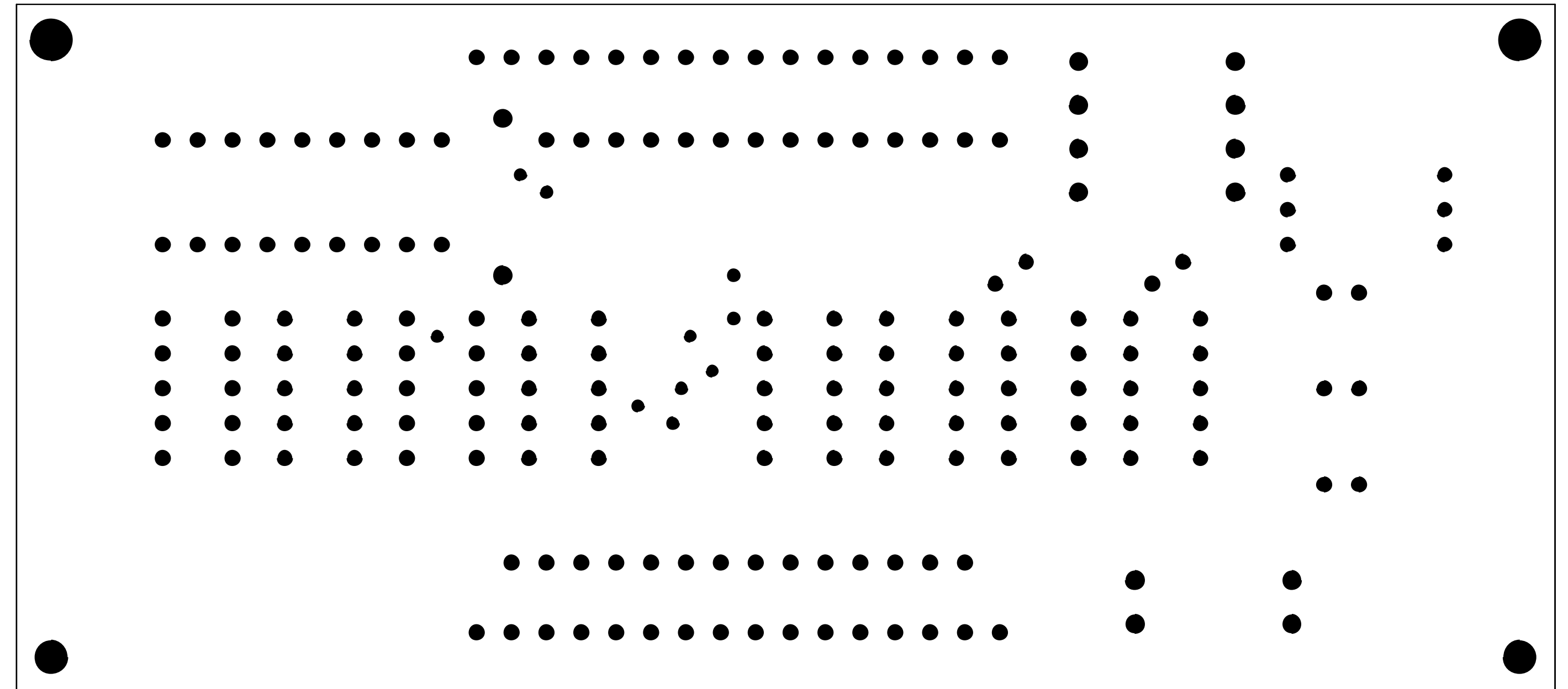

www.agilent.com

Contact us

To obtain service, warranty, or technical support assistance, contact us at the following phone numbers:

United States:

(tel) 800 829 4444 (fax) 800 829 4433

Canada:

(tel) 877 894 4414 (fax) 800 746 4866

China:

(tel) 800 810 0189 (fax) 800 820 2816

Europe:

(tel) 31 20 547 2111

Japan:

(tel) (81) 426 56 7832 (fax) (81) 426 56 7840

Korea:

(tel) (080) 769 0800 (fax) (080) 769 0900

Latin America:

(tel) (305) 269 7500

Taiwan:

(tel) 0800 047 866 (fax) 0800 286 331

Other Asia Pacific Countries:

(tel) (65) 6375 8100 (fax) (65) 6755 0042

Or visit Agilent World Wide Web at:

www.agilent.com/find/assist

Product specifications and descriptions in this document are subject to change without notice. Always refer to the English version at the Agilent Web site for the latest revision.

© Agilent Technologies, Inc. 2002–2014

Printed in Malaysia
Eleventh Edition, April 21, 2014

5959-5329

