

TOSHIBA

FILE NO. A02-014
Revised Nov. 2003

SERVICE MANUAL

AIR-CONDITIONER

SPLIT TYPE

RAV-SM560AT-E/RAV-SM800AT-E
RAV-SM560UT-E/RAV-SM800UT-E
RAV-SM560BT-E/RAV-SM800BT-E
RAV-SM560KRT-E/RAV-SM800KRT-E
RAV-SM560XT-E/RAV-SM800XT-E

File No. A02-014 in the page of the following table has been changed, and the portion is expressed as mark.

Revised page	2, 3, 5, 11, 20, 21, 29, 57, 59, 60, 63, 64, 168, 170 Cord Heater Installation Work
--------------	---

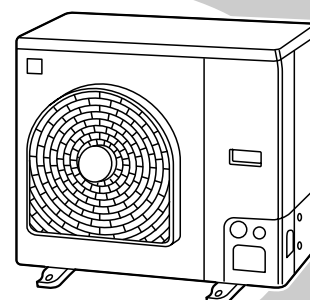
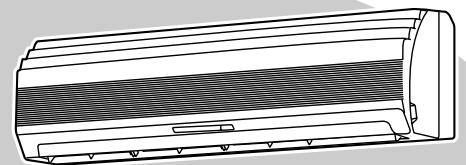
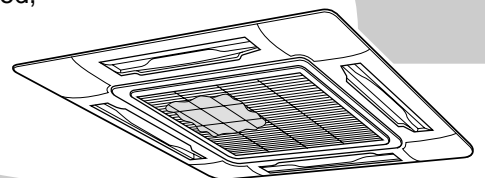

CONTENTS

1. SPECIFICATIONS	3
2. AIR DUCTING WORK	12
3. CONSTRUCTION VIEWS (EXTERNAL VIEWS)	13
4. SYSTEMATIC REFRIGERATING CYCLE DIAGRAM	20
5. WIRING DIAGRAM	22
6. SPECIFICATIONS OF ELECTRICAL PARTS	28
7. REFRIGERANT R410A	30
8. CONTROL BLOCK DIAGRAM	38
9. CIRCUIT CONFIGURATION AND CONTROL SPECIFICATIONS	48
10. TROUBLESHOOTING	65
11. REPLACEMENT OF SERVICE INDOOR P.C. BOARD	88
12. SETUP AT LOCAL SITE AND OTHERS	92
13. ADDRESS SETUP	103
14. TROUBLESHOOTING <WALL TYPE>	108
15. DETACHMENTS	135
16. EXPLODED VIEWS AND PARTS LIST	168
CORD HEATER INSTALLATION WORK	APPENDIX-1

1. SPECIFICATIONS

1-1. Indoor Unit

1-1-1. 4-Way Air Discharge Cassette Type

Model name		RAV-SM560UT-E			RAV-SM800UT-E		
Standard capacity (Note 1) (kW)		Cooling	Heating	Average	Cooling	Heating	Average
		5.3 (1.5 – 5.6)	5.6 (1.5 – 6.3)		7.1 (2.2 – 8.0)	8.0 (2.2–9.0)	
Heating low temp. capacity (Note 1) (kW)		4.9			7		
Energy consumption effect ratio (Cooling)		3.01 [B]	3.90 [A]	3.46	3.03 [B]	3.45 [B]	3.24
Electrical characteristics	Power supply	1 phase 230V (220 – 240V) 50Hz					
	Running current (A)	8.42–7.72	6.87–6.29		11.32–10.37	11.22–10.28	
	Power consumption (kW)	1.76	1.435		2.34	2.32	
	(Low temp.) (kW)	1.89			2.73		
	Power factor (%)	95	95		94	94	
Appearance	Main unit	Zinc hot dipping steel plate					
	Ceiling Panel (Sold separately)	Model	RBC-U21PG (W) E				
		Panel color	Moon-white (Muncel 2.5GY 9.0/0.5)				
Outer dimension	Main unit	Height (mm)	256				
		Width (mm)	840				
		Depth (mm)	840				
	Ceiling panel (Sold separately)	Height (mm)	53				
		Width (mm)	950				
		Depth (mm)	950				
Total weight	Main unit (kg)	21			22		
	Ceiling panel	4.5					
Heat exchanger		Finned tubu					
Soundproof/Heat-insulating material		Inflammable polyethylene foam			Foamed polyethylen		
Fan unit	Fan	Turbo fan					
	Standard air flow High (Mid./Low) (m ³ /h)	1050			1200		
	Motor (W)	60					
Air filter		Attached ceiling panel					
Controller (Sold separately)		RBC-AMT21E					
Connecting pipe	Gas side (mm)	Ø12.7 (1/2")			Ø15.9 (5/8")		
	Liquid side (mm)	Ø6.4 (1/4")			Ø9.5 (3/8")		
	Drain port (Nominal dia.)	25 (Polyvinyl chloride tube)					
Sound level	High (Mid./Low) (Note 2) (dB•A)	32	29	27	34	31	28

Note 1 : The cooling capacities and electrical characteristics are measured under the conditions specified by JIS B 8616 based on the reference piping. The reference piping consists of 3 m of main piping and 2 m of branch piping connected with 0 meter height.

Note 2 : The sound level is measured in an anechoic chamber in accordance with JIS B8616. Normally, the values measured in the actual operating environment become larger than the indicated values due to the effects of external sound.

Note : Rated conditions Cooling : Indoor air temperature 27°C DB/19°C WB, Outdoor air temperature 35°C DB
Heating : Indoor air temperature 20°C DB, Outdoor air temperature 7°C DB/6°C WB

• Operation characteristic curve

<Cooling>

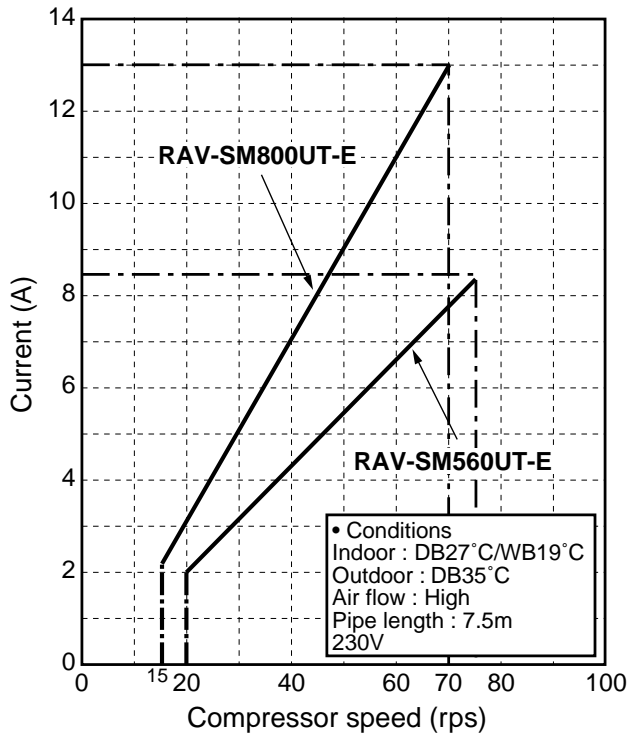

<Heating>

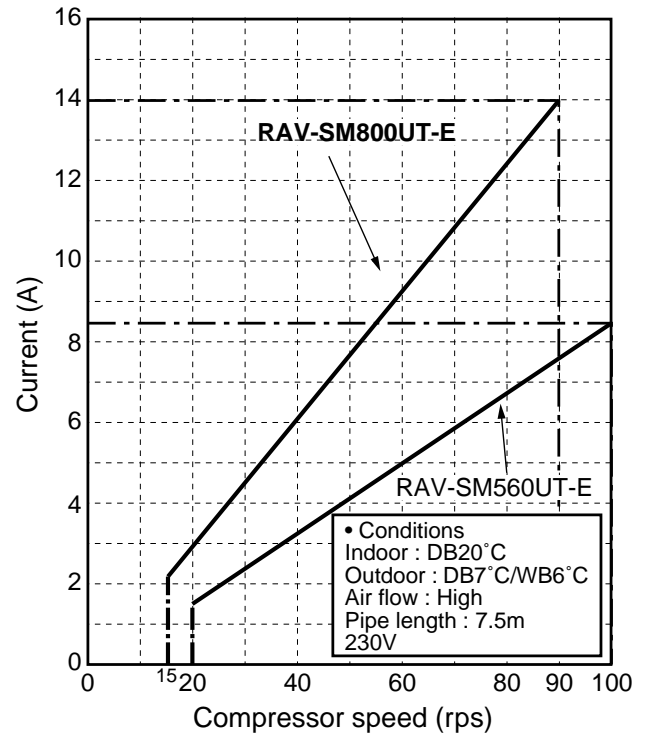

• Capacity variation ratio according to temperature

<Cooling>

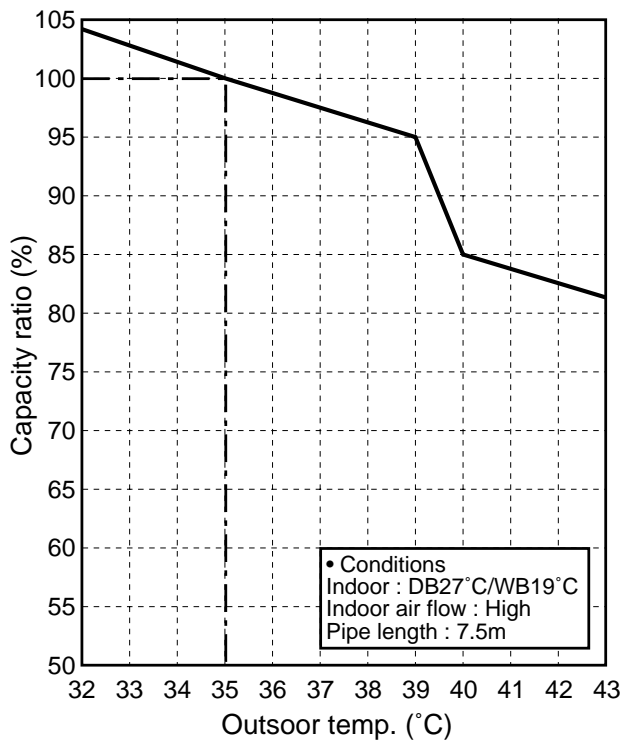

<Heating>

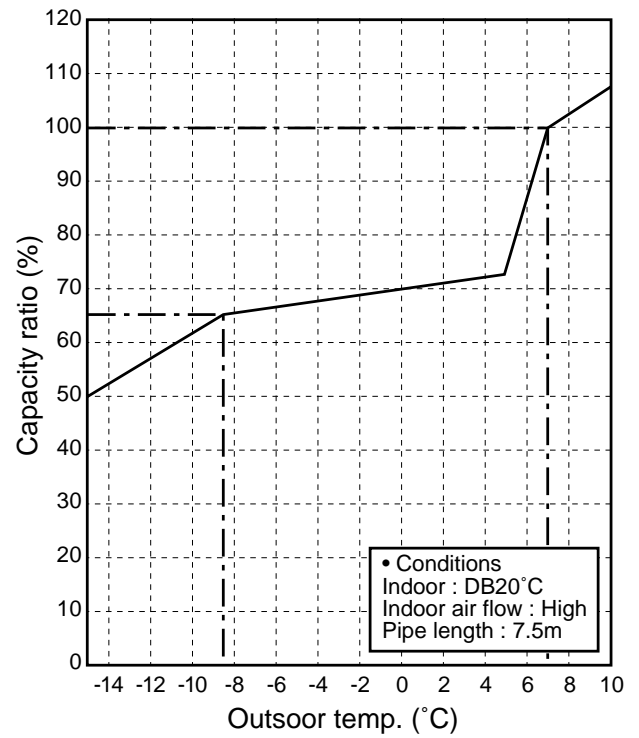

1-1-2. Concealed Duct Type

Model name		RAV-SM560BT-E			RAV-SM800BT-E		
Standard capacity (Note 1) (kW)		Cooling	Heating	Average	Cooling	Heating	Average
		5.0 (1.5 – 5.6)	5.6 (1.5 – 6.3)		7.1 (2.2 – 8.0)	8.0 (2.2–9.0)	
Heating low temp. capacity (Note 1) (kW)		4.6			6.2		
Energy consumption effect ratio (Cooling)		2.60 [D]	3.27 [C]	2.94	2.73 [D]	3.21 [C]	2.97
Electrical characteristics	Power supply	1 phase 230V (220 – 240V) 50Hz					
	Running current (A)	9.19–8.42	8.18–7.50		12.57–11.52	12.04–11.04	
	Power consumption (kW)	1.92	1.71		2.60	2.49	
	(Low temp.) (kW)	1.78			2.62		
	Power factor (%)	95	95		94	94	
Appearance	Main unit	Zinc hot dipping steel plate					
	Ceiling Panel (Sold separately)	Model	—				
		Panel color	—				
Outer dimension	Main unit	Height (mm)	320				
		Width (mm)	700				
		Depth (mm)	800 (+7.5)				
	Ceiling panel (Sold separately)	Height (mm)	—				
		Width (mm)	—				
		Depth (mm)	—				
Total weight	Main unit (kg)	39			53		
	Ceiling panel	—					
Heat exchanger		Finned tubu					
Soundproof/Heat-insulating material		Inflammable polyethylene foam			Foamed polyethylen		
Fan unit	Fan	Multi-blade fan					
	Standard air flow High (Mid./Low) (m ³ /h)	840			1140		
	Motor (W)	60			100		
Air filter		Attached main unit					
Controller (Sold separately)		RBC-AMT21E					
Connecting pipe	Gas side (mm)	Ø12.7 (1/2")			Ø15.9 (5/8")		
	Liquid side (mm)	Ø6.4 (1/4")			Ø9.5 (3/8")		
	Drain port (Nominal dia.)	25 (Polyvinyl chloride tube)					
Sound level	High (Mid./Low) (Note 2) (dB•A)	42	39	36	43	40	37

Note 1 : The cooling capacities and electrical characteristics are measured under the conditions specified by JIS B 8616 based on the reference piping. The reference piping consists of 3 m of main piping and 2 m of branch piping connected with 0 meter height.

Note 2 : The sound level is measured in an anechoic chamber in accordance with JIS B8616. Normally, the values measured in the actual operating environment become larger than the indicated values due to the effects of external sound.

Note : Rated conditions Cooling : Indoor air temperature 27°C DB/19°C WB, Outdoor air temperature 35°C DB
Heating : Indoor air temperature 20°C DB, Outdoor air temperature 7°C DB/6°C WB

• Operation characteristic curve

<Cooling>

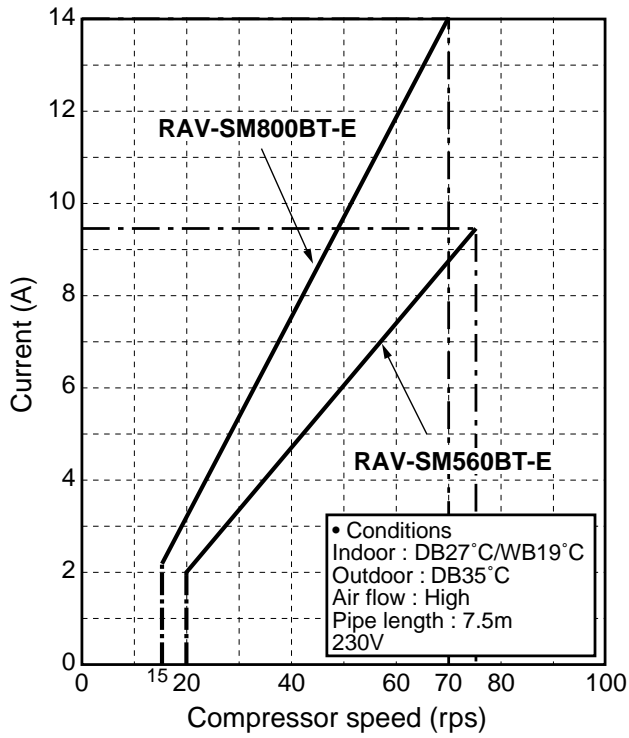

<Heating>

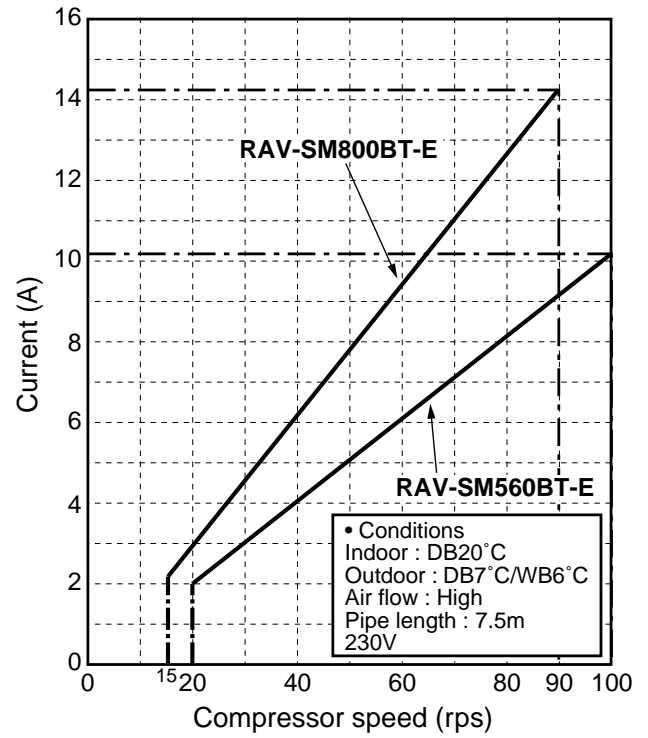

• Capacity variation ratio according to temperature

<Cooling>

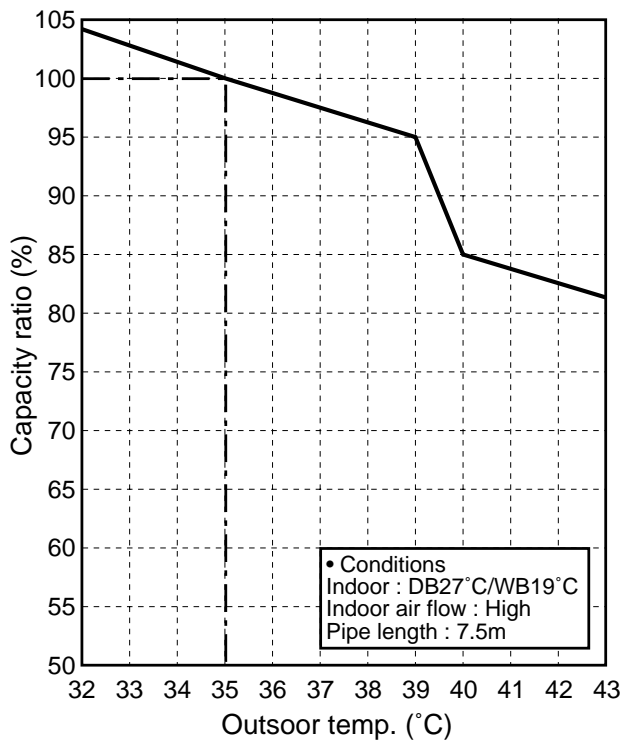

<Heating>

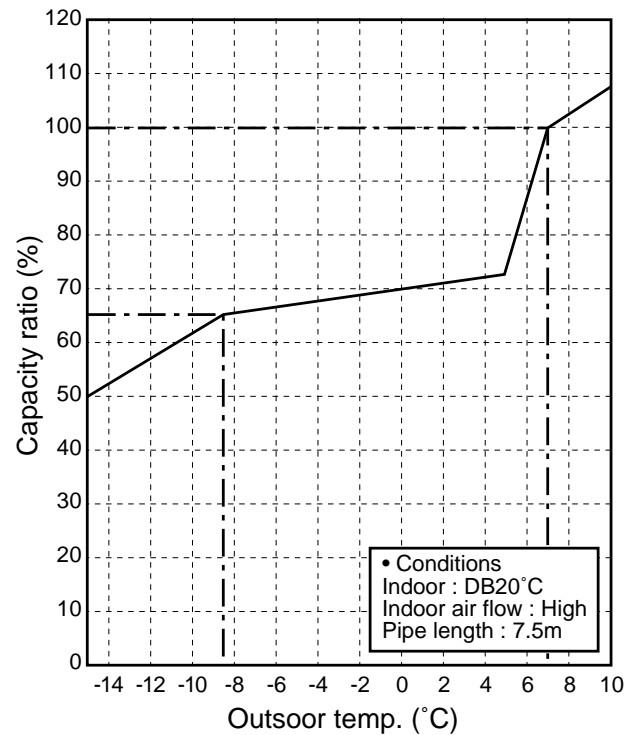

1-1-3. High-Wall Type

Model name		RAV-SM560KRT-E			RAV-SM800KRT-E		
Standard capacity (Note 1) (kW)		Cooling	Heating	Average	Cooling	Heating	Average
		5.1 (1.5 – 5.6)	5.6 (1.5 – 6.3)		6.7 (2.2 – 8.0)	8 (2.2–9.0)	
Heating low temp. capacity (Note 1) (kW)		4.9			5.8		
Energy consumption effect ratio (Cooling)		2.93 [D]	3.29 [C]	3.11	2.46 [E]	3.00 [D]	3.24
Electrical characteristics	Power supply	1 phase 230V (220 – 240V) 50Hz					
	Running current (A)	8.33–7.63	8.138–7.46		13.15–12.05	12.91–11.84	
	Power consumption (kW)	1.74	1.7		2.72	2.67	
	(Low temp.) (kW)	1.95			2.21		
	Power factor (%)	95	95		94	94	
Appearance	Main unit	Pure white					
	Ceiling Panel (Sold separately)	Model	—				
		Panel color	—				
Outer dimension	Main unit	Height (mm)	298				
		Width (mm)	998				
		Depth (mm)	208				
	Ceiling panel (Sold separately)	Height (mm)	—				
		Width (mm)	—				
		Depth (mm)	—				
Total weight	Main unit (kg)	12					
	Ceiling panel	—					
Heat exchanger		Finned tubu					
Soundproof/Heat-insulating material		Inflammable polyethylene foam			Foamed polyethylen		
Fan unit	Fan	Turbo fan					
	Standard air flow High (Mid./Low) (m ³ /h)	840			1110		
	Motor (W)	30					
Air filter		Attached main unit					
Controller (Sold separately)		Wired remote controller RBC-AMT21E					
Connecting pipe	Gas side (mm)	Ø12.7 (1/2")			Ø15.9 (5/8")		
	Liquid side (mm)	Ø6.4 (1/4")			Ø9.5 (3/8")		
	Drain port (Nominal dia.)	25 (Polyvinyl chloride tube)					
Sound level	High (Mid./Low) (Note 2) (dB•A)	45	41	36	45	41	36

Note 1 : The cooling capacities and electrical characteristics are measured under the conditions specified by JIS B 8616 based on the reference piping. The reference piping consists of 3 m of main piping and 2 m of branch piping connected with 0 meter height.

Note 2 : The sound level is measured in an anechoic chamber in accordance with JIS B8616. Normally, the values measured in the actual operating environment become larger than the indicated values due to the effects of external sound.

Note : Rated conditions Cooling : Indoor air temperature 27°C DB/19°C WB, Outdoor air temperature 35°C DB
Heating : Indoor air temperature 20°C DB, Outdoor air temperature 7°C DB/6°C WB

• Operation characteristic curve

<Cooling>

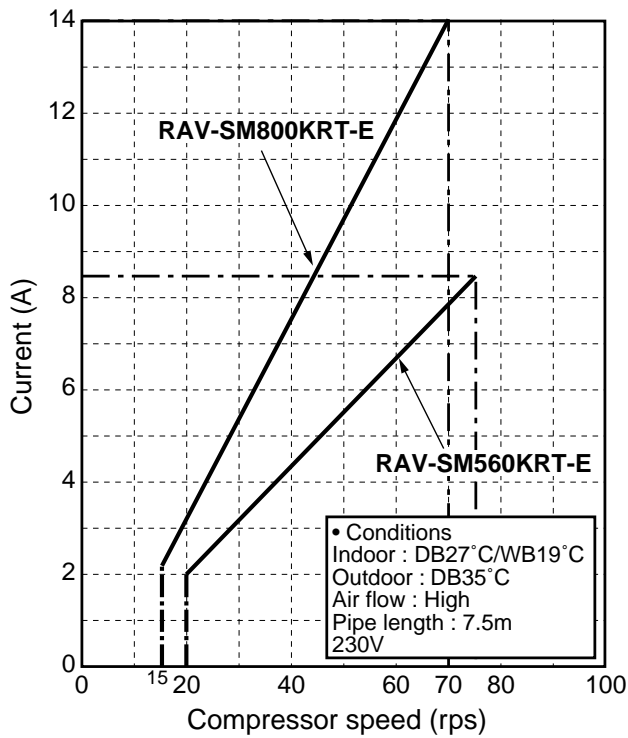

<Heating>

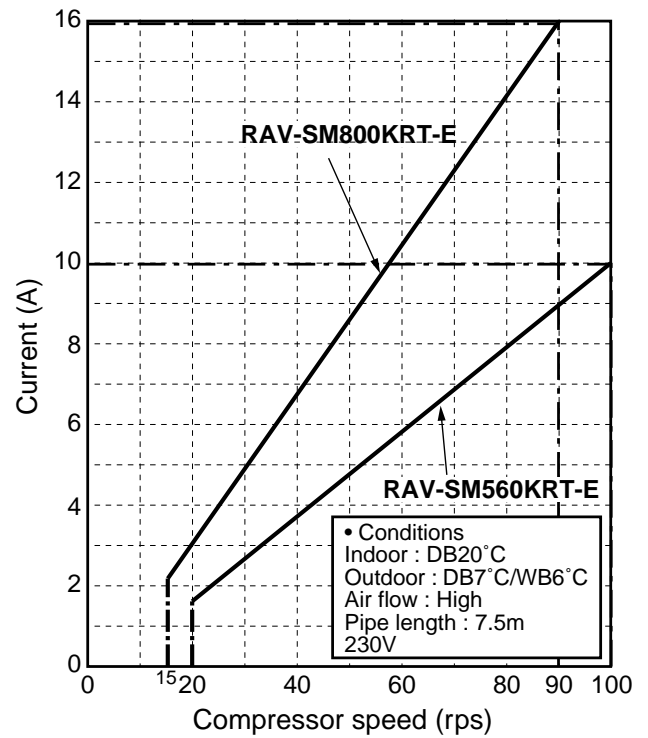

• Capacity variation ratio according to temperature

<Cooling>

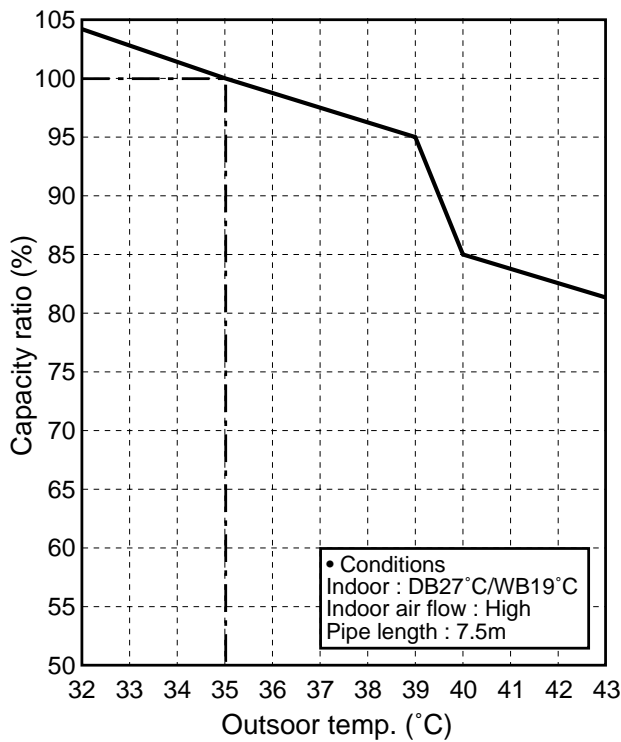

<Heating>

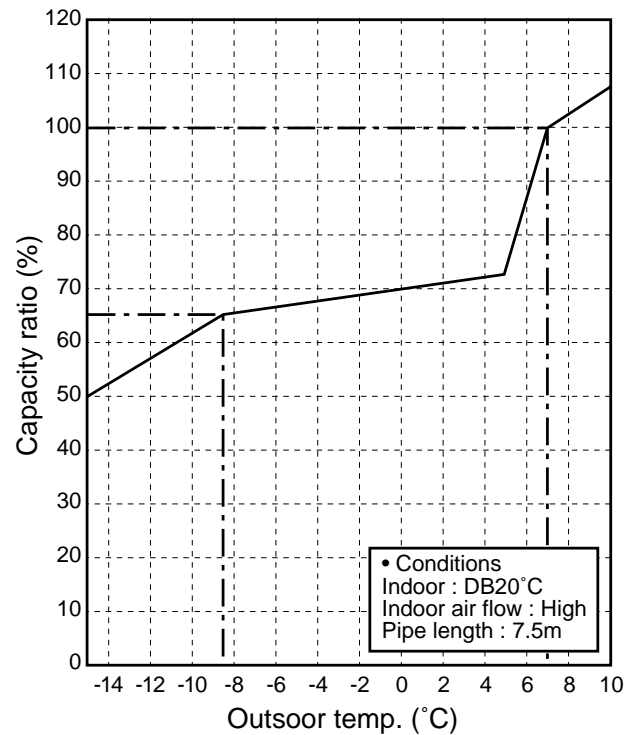

1-1-4. Flexible Type

Model name		RAV-SM560XT-E			RAV-SM800XT-E			
Standard capacity (Note 1)	(kW)	Cooling	Heating	Average	Cooling	Heating	Average	
		5.1 (1.5 – 5.6)	5.6 (1.5 – 6.3)		6.7 (2.2 – 8.0)	8 (2.2–9.0)		
Heating low temp. capacity (Note 1) (kW)		4.9			5.8			
Energy consumption effect ratio (Cooling)		2.93 [D]	3.29 [C]	3.11	2.46 [E]	3.00 [D]	3.24	
Electrical characteristics	Power supply		1 phase 230V (220 – 240V) 50Hz					
	Running current	(A)	8.33–7.63	8.138–7.46		13.15–12.05	12.91–11.84	
	Power consumption	(kW)	1.74	1.7		2.72	2.67	
	(Low temp.)	(kW)	1.95			2.21		
	Power factor	(%)	95	95		94	94	
Appearance	Main unit		Pure white					
	Ceiling Panel (Sold separately)	Model	—					
		Panel color	—					
Outer dimension	Main unit	Height (mm)	298					
		Width (mm)	998					
		Depth (mm)	208					
	Ceiling panel (Sold separately)	Height (mm)	—					
		Width (mm)	—					
		Depth (mm)	—					
Total weight	Main unit (kg)		12					
	Ceiling panel		—					
Heat exchanger		Finned tubu						
Soundproof/Heat-insulating material		Inflammable polyethylene foam			Foamed polyethylen			
Fan unit	Fan		Cross flow fan					
	Standard air flow High (Mid./Low)	(m ³ /h)	840			1110		
	Motor	(W)	30					
Air filter		Attached main unit						
Controller (Sold separately)		Wired remote controller RBC-AMT21E						
Connecting pipe	Gas side	(mm)	Ø12.7 (1/2")			Ø15.9 (5/8")		
	Liquid side	(mm)	Ø6.4 (1/4")			Ø9.5 (3/8")		
	Drain port	(Nominal dia.)	25 (Polyvinyl chloride tube)					
Sound level	High (Mid./Low) (Note 2)	(dB•A)	39	36	36	45	41	36

Note 1 : The cooling capacities and electrical characteristics are measured under the conditions specified by JIS B 8616 based on the reference piping. The reference piping consists of 3 m of main piping and 2 m of branch piping connected with 0 meter height.

Note 2 : The sound level is measured in an anechoic chamber in accordance with JIS B8616. Normally, the values measured in the actual operating environment become larger than the indicated values due to the effects of external sound.

Note : Rated conditions Cooling : Indoor air temperature 27°C DB/19°C WB, Outdoor air temperature 35°C DB
Heating : Indoor air temperature 20°C DB, Outdoor air temperature 7°C DB/6°C WB

• Operation characteristic curve

<Cooling>

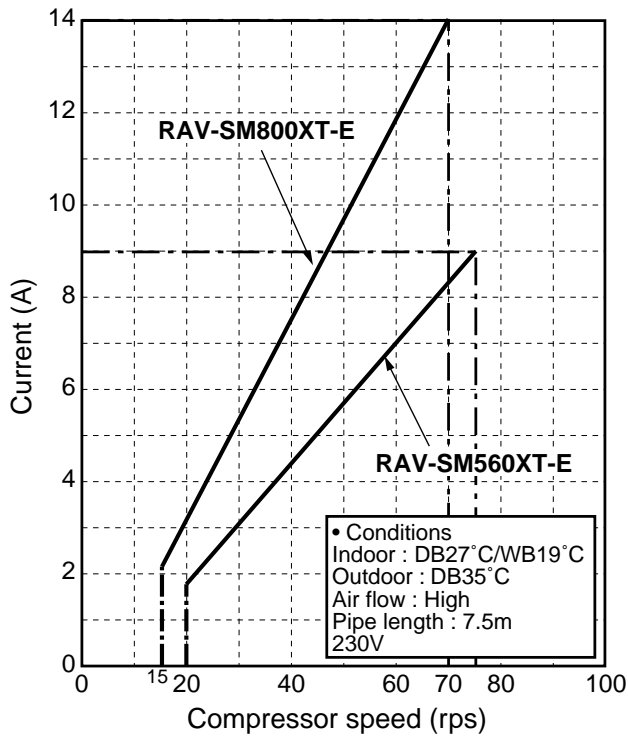

<Heating>

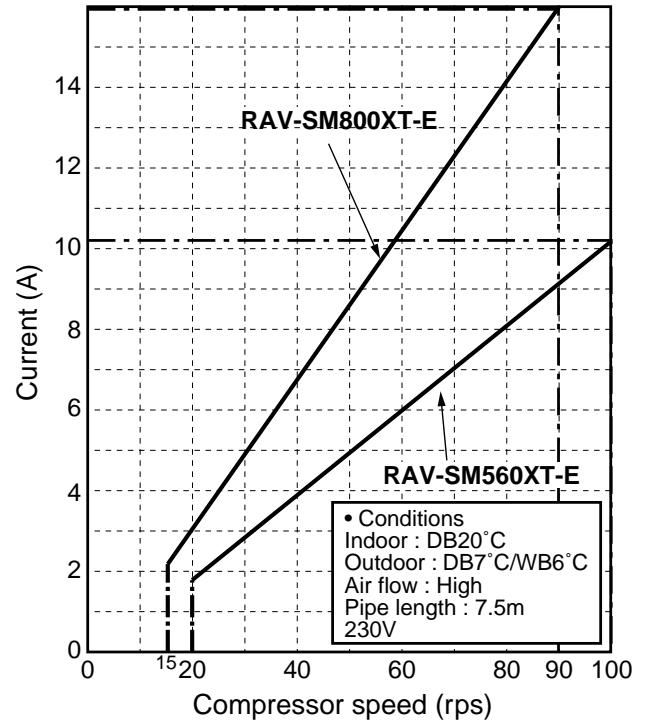

• Capacity variation ratio according to temperature

<Cooling>

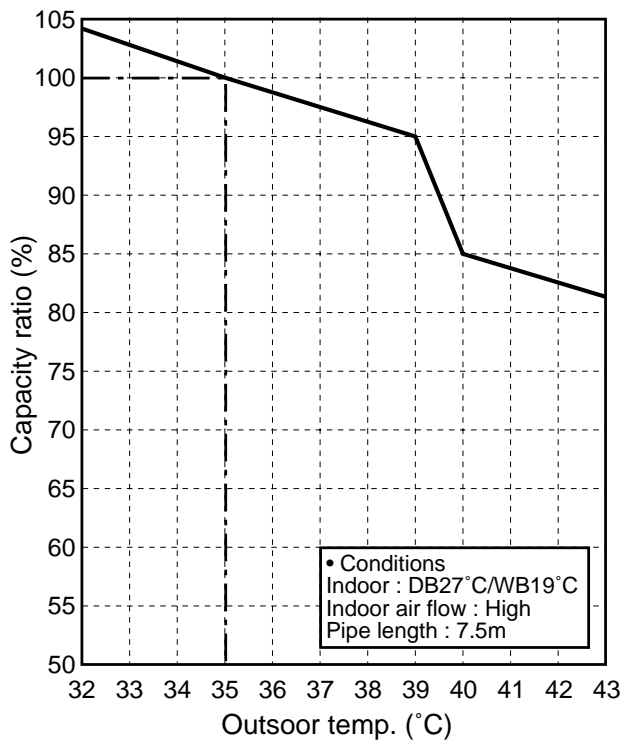

<Heating>

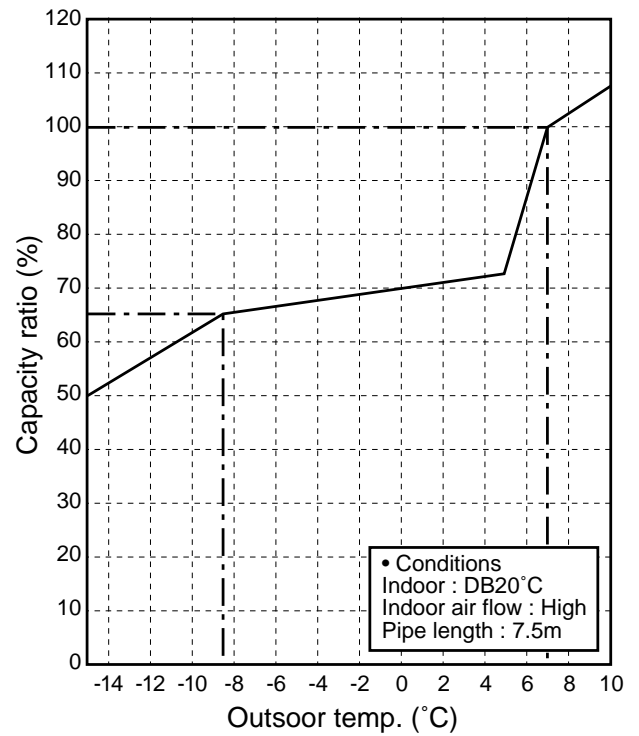

1-2. Outdoor Unit

Model name		RAV-SM560AT-E	RAV-SM800AT-E	
Appearance		Silky shade (Muncel 1Y8.5/0.5)		
Power supply		1 phase 230V (220 – 240V) 50Hz (Power exclusive to outdoor is required.)		
Compressor	Type	Hermetic compressor		
	Motor (kW)	1.1	1.6	
	Pole	4 poles		
Refrigerant charged (kg)		R410A 0.9	R410A 1.5	
Refrigerant control		Pulse motor valve		
Pipe	Standard length	20 (without additional charge)		
	Max. total length (m)	30	50	
	Over 20m	Add 20g/m (Max. 200g)	Add 40g/m (Max. 1200g)	
	Height difference	Outdoor lower (m)	30	
		Outdoor higher (m)	50	
Outer dimension	Height (mm)	595	795	
	Width (mm)	780	780	
	Depth (mm)	270	270	
Total weight (kg)		35	55	
Heat exchanger		Finned tube		
Fan unit	Fan	Propeller fan		
	Standard air flow High (m ³ /h)	2400	3400	
	Motor (W)	43	63	
Connecting pipe	Gas side (mm)	Ø12.7 (1/2")	Ø15.9 (5/8")	
	Liquid side (mm)	Ø6.4 (1/4")	Ø9.5 (3/8")	
Protection device		Discharge temp. sensor Over-current sensor Compressor thermo.		
Sound level (Note 2)	High (Mid./Low) (Cooling/Heating) (dB•A)	46/48	48/50	

Note 1 : The cooling capacities and electrical characteristics are measured under the conditions specified by JIS B 8616 based on the reference piping. The reference piping consists of 3 m piping connected with 0 meter height.

Note 2 : The sound level is measured in an anechoic chamber in accordance with JIS B8616. Normally, the values measured in the actual operating environment become larger than the indicated values due to the effects of external sound.

Note : Rated conditions Cooling : Indoor air temperature 27°C DB/19°C WB, Outdoor air temperature 35°C DB
Heating : Indoor air temperature 20°C DB, Outdoor air temperature 7°C DB/6°C WB

1-3. Combination Specifications of Indoor Units with Outdoor Units

4-way Air Discharge Cassette type

Indoor Unit		RAV-SM560UT-E		RAV-SM800UT-E		RAV-SP1100UT-E		RAV-SM1400UT-E	
Outdoor Unit		RAV-SP560AT-E		RAV-SP800AT-E		RAV-SP1100AT-E		RAV-SP1400AT-E	
Standard capacity (Note 1)	(kW)	Cooling	Heating	Cooling	Heating	Cooling	Heating	Cooling	Heating
		5.30 (2.20-5.60)	5.60 (2.20-7.10)	7.10 (2.20-8.00)	8.00 (2.20-10.00)	10.00 (3.00-12.00)	11.20 (3.00-13.00)	12.50 (3.00-14.00)	14.00 (3.00-16.50)
Energy consumption effect ratio		3.46	4.67	3.68	3.94	4.17	4.27	3.51	3.91
Electrical characteristics	Power supply	1 phase 230V (220-240V) 50Hz							
	Running current (A)	7.17-6.57	5.62-5.15	8.95-8.21	9.42-8.63	11.24-10.31	12.28-11.25	16.51-15.14	16.60-15.22
	Power consumption (kW)	1.53	1.20	1.93	2.03	2.40	2.62	3.56	3.58
	Power factor (%)	97	97	98	98	97	97	98	98
Sound level Indoor unit	High/Mid./Low (Note 2) (dB•A)	32/29/27		34/31/28		39/36/33		42/38/34	

Concealed Duct type

Indoor Unit		RAV-SM561BT-E		RAV-SM801BT-E		RAV-SM1101BT-E		RAV-SM1401BT-E	
Outdoor Unit		RAV-SP560AT-E		RAV-SP800AT-E		RAV-SP1100AT-E		RAV-SP1400AT-E	
Standard capacity (Note 1)	(kW)	Cooling	Heating	Cooling	Heating	Cooling	Heating	Cooling	Heating
		5.00 (2.20-5.60)	5.60 (2.20-7.00)	7.10 (2.20-8.00)	8.00 (2.20-10.00)	10.00 (3.00-12.00)	11.20 (3.00-13.00)	12.50 (3.00-14.00)	14.00 (3.00-16.50)
Energy consumption effect ratio		3.60	4.67	3.38	3.94	4.00	4.27	3.21	3.91
Electrical characteristics	Power supply	1 phase 230V (220-240V) 50Hz							
	Running current (A)	6.51-5.97	7.26-6.66	9.74-8.93	9.74-8.93	11.72-10.74	11.72-10.74	18.09-16.58	16.70-15.31
	Power consumption (kW)	1.39	1.55	2.10	2.10	2.50	2.50	3.90	3.60
	Power factor (%)	97	97	98	98	97	97	98	98
Sound level Indoor unit	High/Mid./Low (Note 2) (dB•A)	40/37/33		40/37/34		42/39/36		44/41/38	

Under Ceiling type

Indoor Unit		RAV-SM561CT-E		RAV-SM801CT-E		RAV-SM1101CT-E		RAV-SM1401CT-E	
Outdoor Unit		RAV-SP560AT-E		RAV-SP800AT-E		RAV-SP1100AT-E		RAV-SP1400AT-E	
Standard capacity (Note 1)	(kW)	Cooling	Heating	Cooling	Heating	Cooling	Heating	Cooling	Heating
		5.00 (2.20-5.60)	5.60 (2.20-7.00)	7.10 (2.20-8.00)	8.00 (2.20-10.00)	10.00 (3.00-12.00)	11.20 (3.00-13.00)	12.50 (3.00-14.00)	14.00 (3.00-16.50)
Energy consumption effect ratio		3.55	3.73	3.38	3.64	4.17	4.48	3.21	3.73
Electrical characteristics	Power supply	1 phase 230V (220-240V) 50Hz							
	Running current (A)	6.61-6.06	7.03-6.44	9.74-8.93	10.20-9.35	11.24-10.31	11.72-10.74	18.09-16.58	17.39-15.94
	Power consumption (kW)	1.41	1.50	2.10	2.20	2.40	2.50	3.90	3.75
	Power factor (%)	97	97	98	98	97	97	98	98
Sound level Indoor unit	High/Mid./Low (Note 2) (dB•A)	36/33/30		38/36/33		41/38/35		43/40/37	

High wall type

Indoor Unit		RAV-SM560KRT-E		RAV-SM800KRT-E					
Outdoor Unit		RAV-SP560AT-E		RAV-SP800AT-E					
Standard capacity (Note 1)	(kW)	Cooling	Heating	Cooling	Heating	Cooling	Heating	Cooling	Heating
		5.00 (2.20-5.60)	5.60 (2.20-7.00)	6.90 (2.20-8.00)	8.00 (2.20-9.50)				
Energy consumption effect ratio		3.60	3.61	2.88	3.33				
Electrical characteristics	Power supply	1 phase 230V (220-240V) 50Hz							
	Running current (A)	6.51-5.97	7.26-6.66	11.13-10.20	11.13-10.20				
	Power consumption (kW)	1.39	1.55	2.40	2.40				
	Power factor (%)	97	97	98	98				
Sound level Indoor unit	High/Mid./Low (Note 2) (dB•A)	32/29/27		32/29/27					

Note 1 : The cooling capacities and electrical characteristics are measured under the conditions specified by JIS B 8616 based on the reference piping 7.5m.

Note 2 : The sound level is measured in an anechoic chamber in accordance with JIS B8616. Normally, the values measured in the actual operating environment become larger than the indicated values due to the effects of external sound.

Note : Rated conditions Cooling : Indoor air temperature 27°C DB/19°C WB, Outdoor air temperature 35°C DB
Heating : Indoor air temperature 20°C DB, Outdoor air temperature 7°C DB/6°C WB

2. AIR DUCTING WORK

2-1. Static Pressure Characteristics of Each Model

Fig. 1 RAV-SM560BT-E

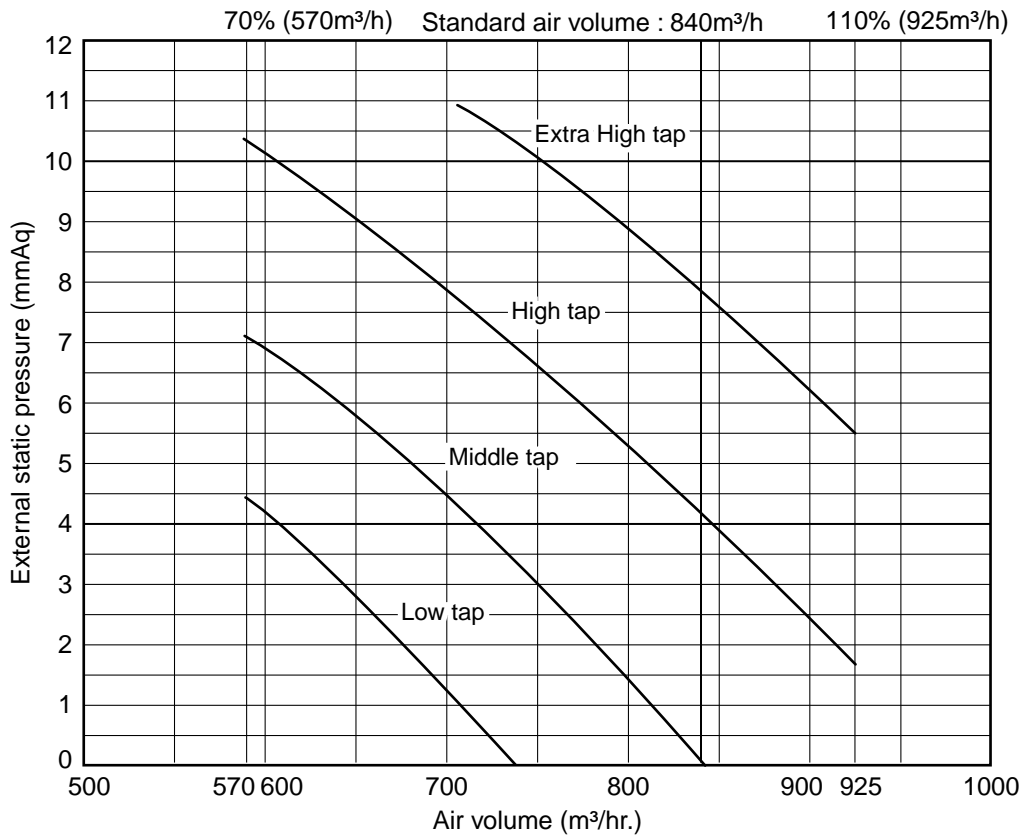
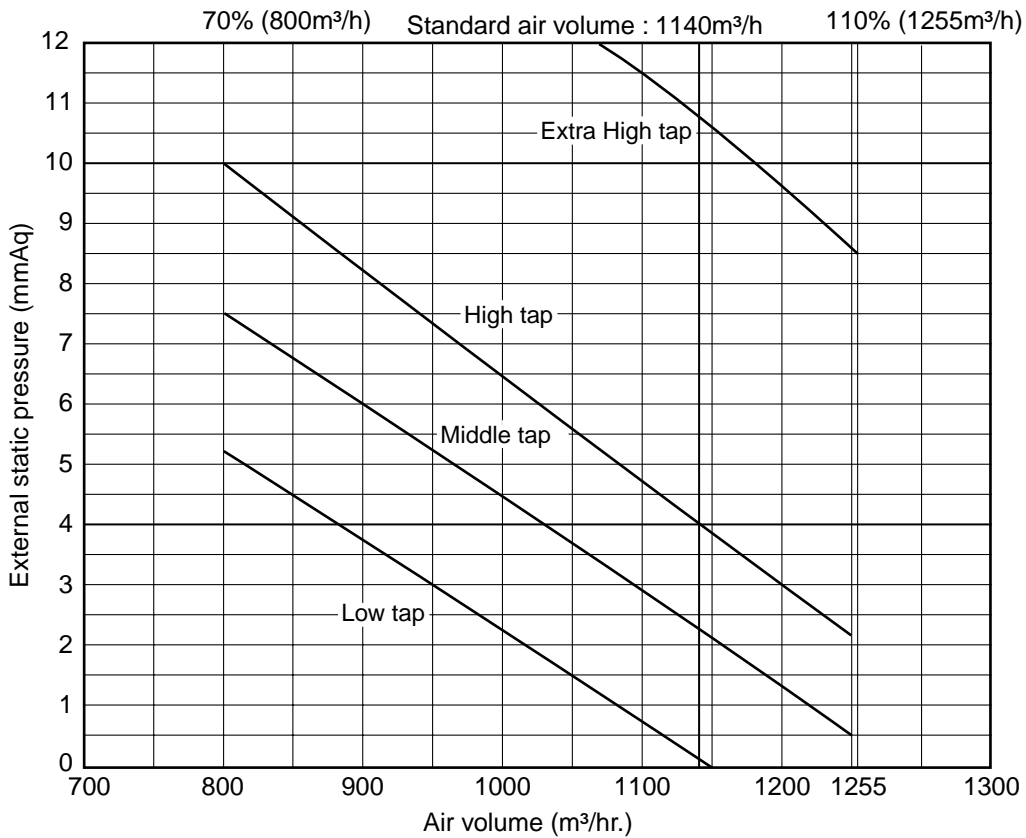

Fig. 2 RAV-SM800BT-E



3. CONSTRUCTION VIEWS (EXTERNAL VIEWS)

3-1. Indoor Unit

4-Way Air Discharge Cassette Type RAV-SM560UT-E/RAV-SM800UT-E

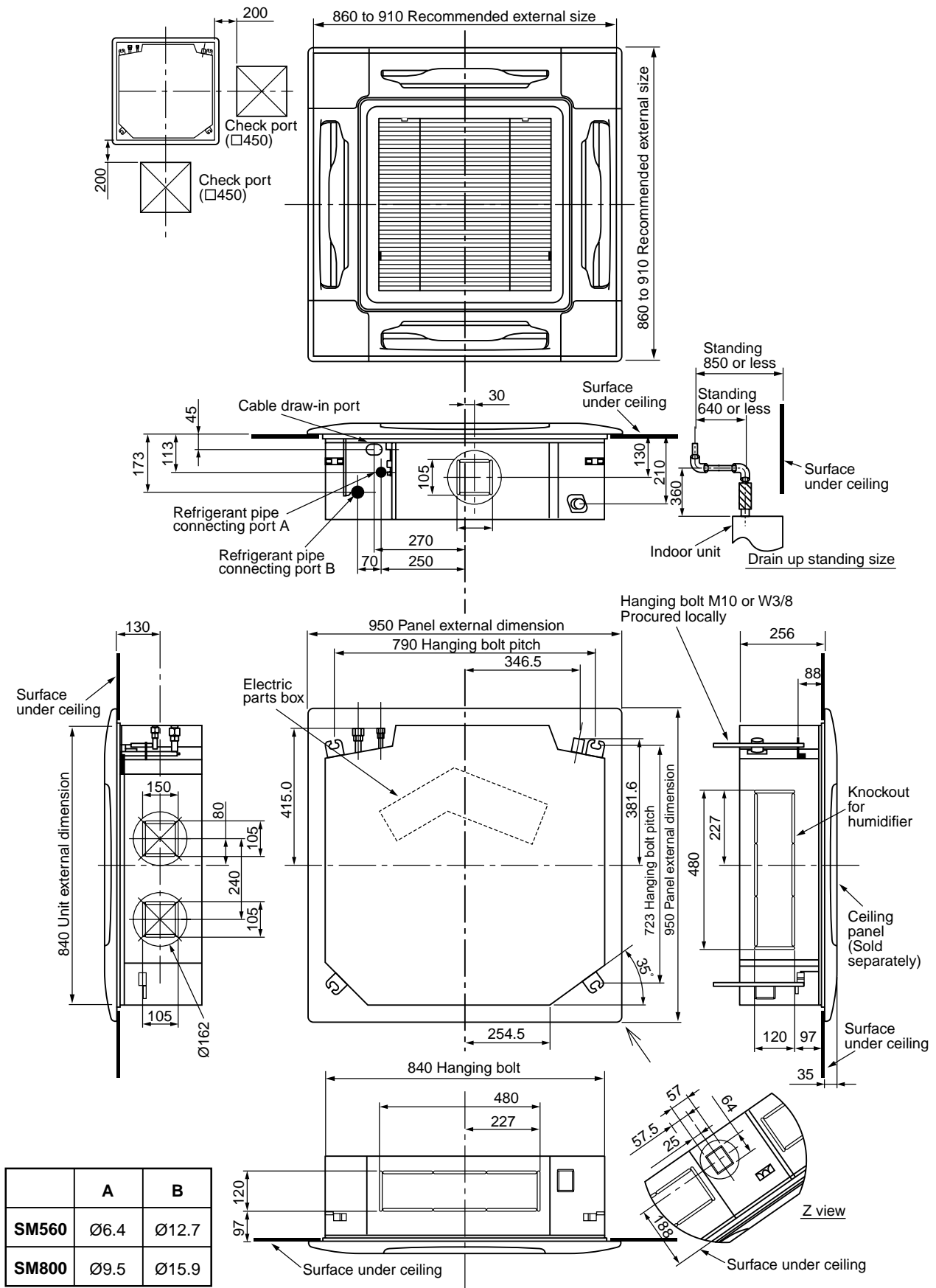

**Concealed Duct Type
RAV-SM560BT-E**

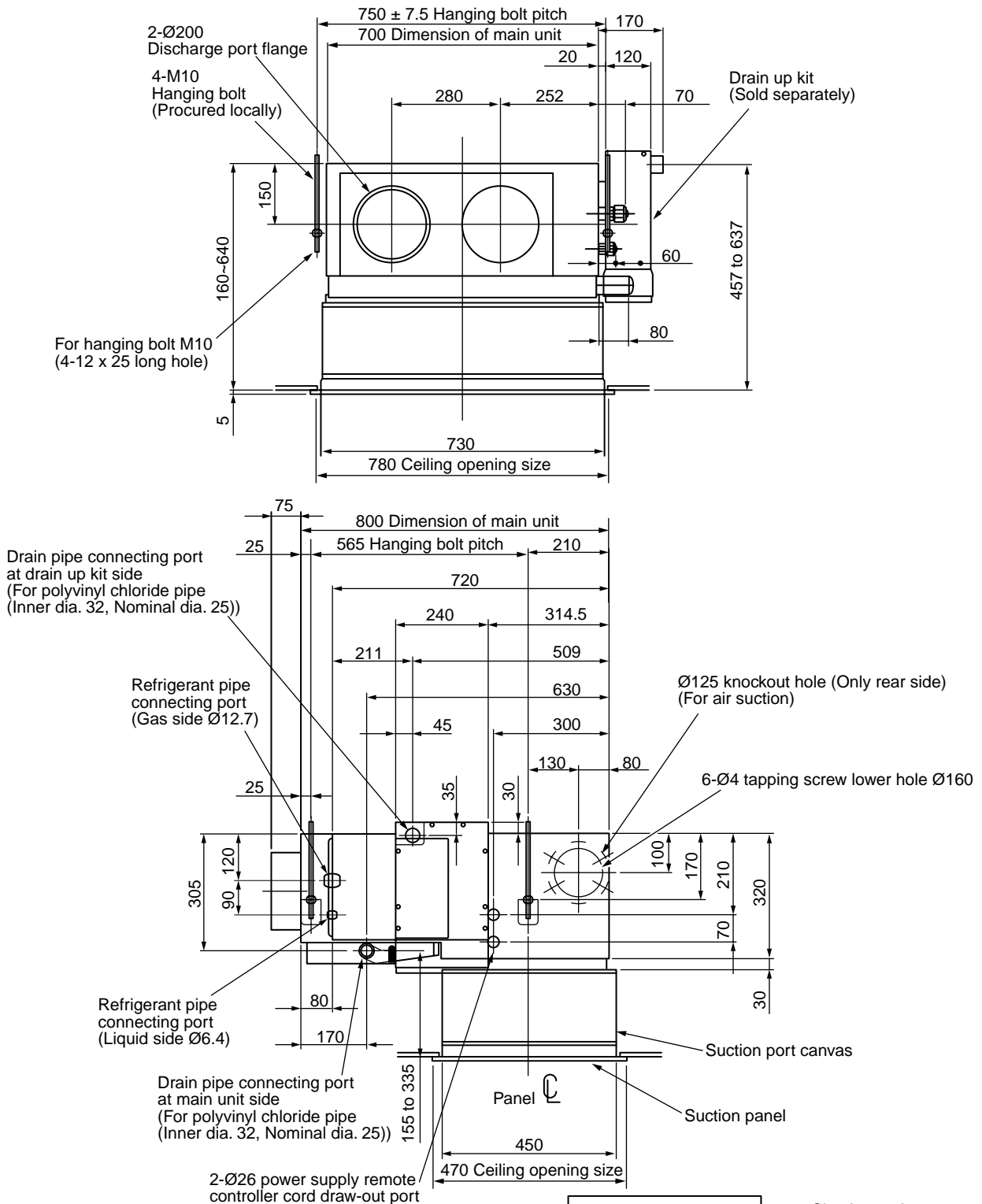

NOTE 1 :
For maintenance of the equipment, be sure to install a check port A at the position as shown below.

NOTE 2 :
Using the drain up kit sold separately, drain-up by 300 (mm) from drain pipe draw-out port of the main unit is necessary. The drain-up over 300mm or more is impossible.

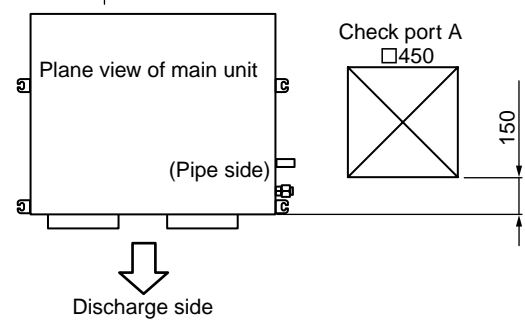

RAV-SM800BT-E

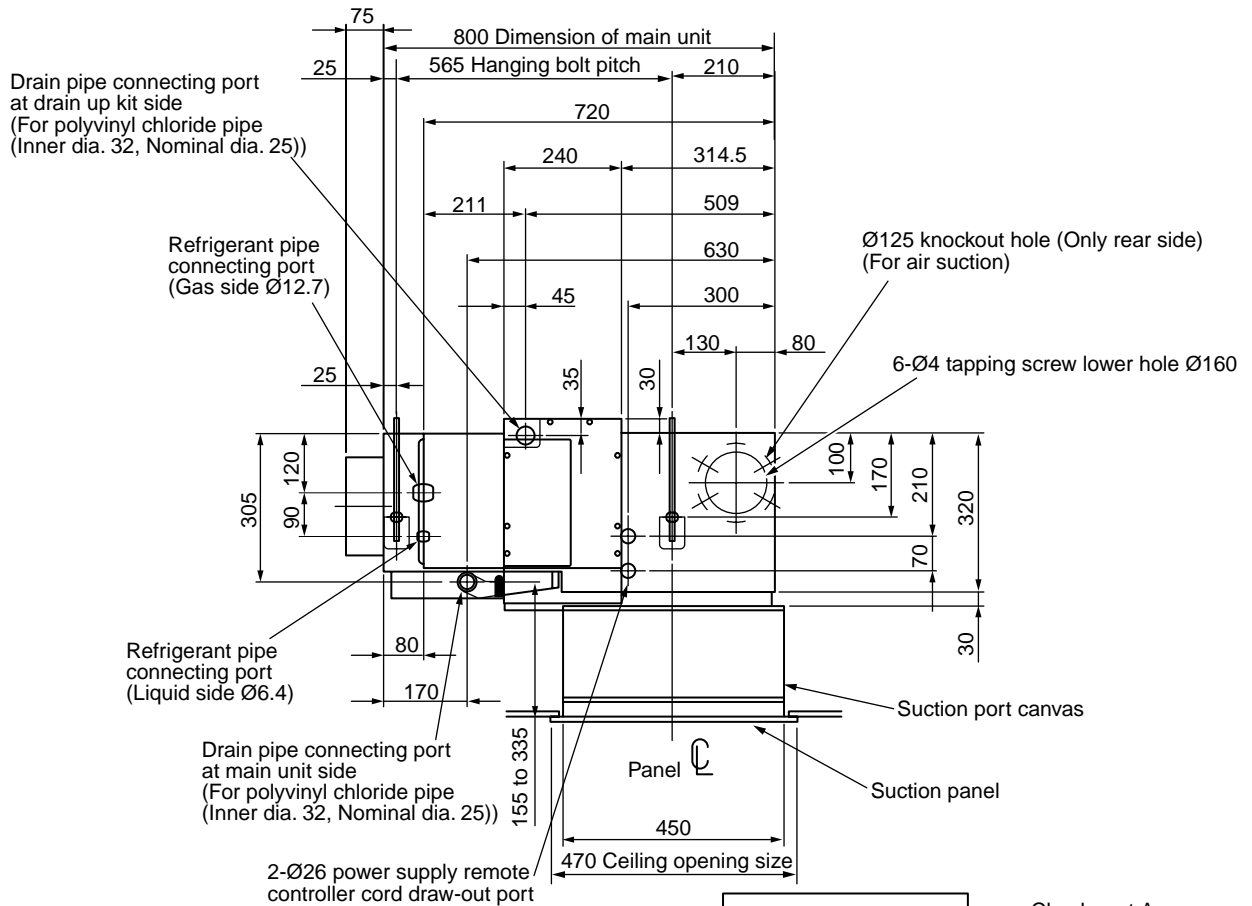
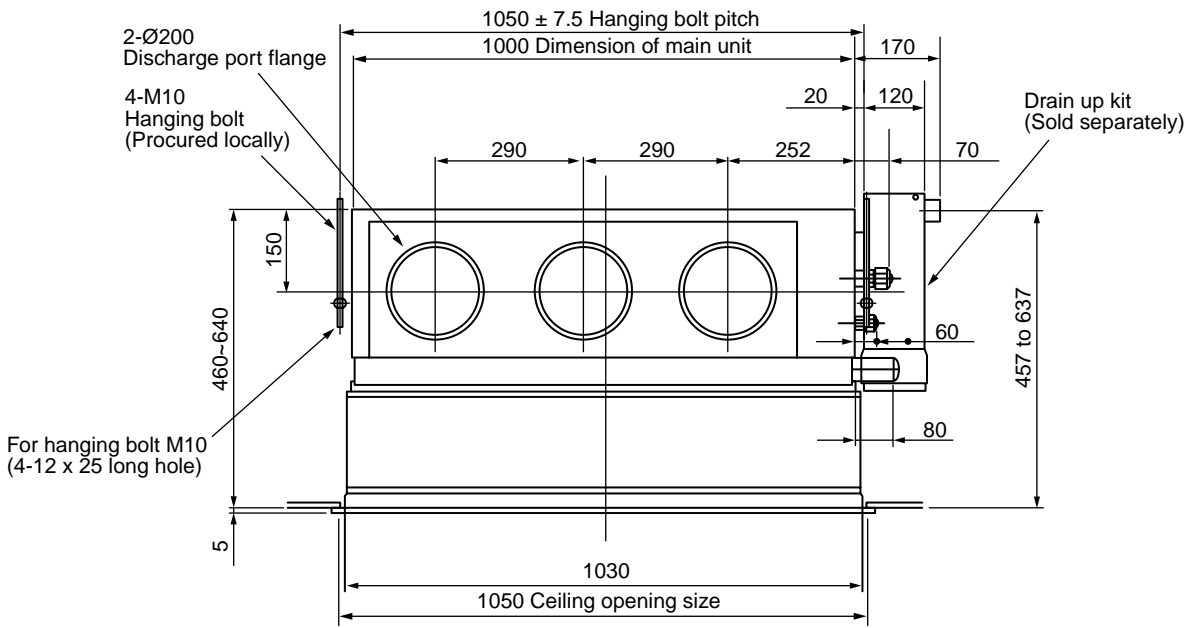

NOTE 1 :
For maintenance of the equipment, be sure to install a check port A at the position as shown below.

NOTE 2 :
Using the drain up kit sold separately, drain-up by 300 (mm) from drain pipe draw-out port of the main unit is necessary. The drain-up over 300mm or more is impossible.

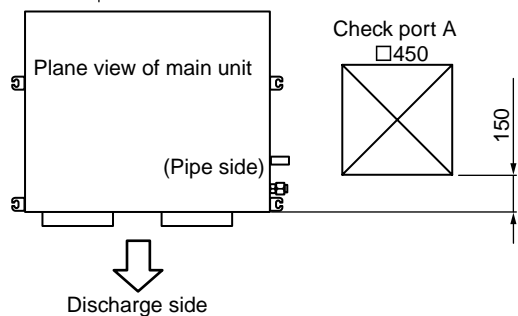

High-Wall Type
RAV-SM560KRT-E/RAV-SM800KRT-E

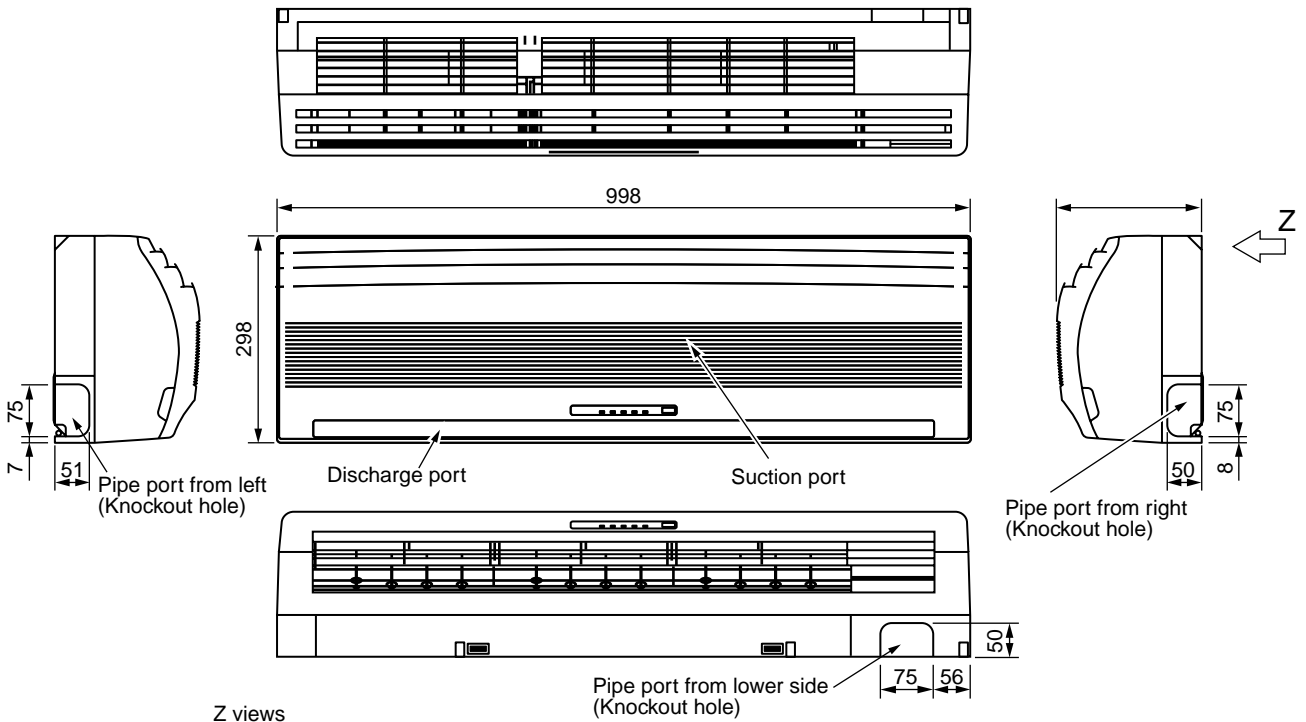

Z views

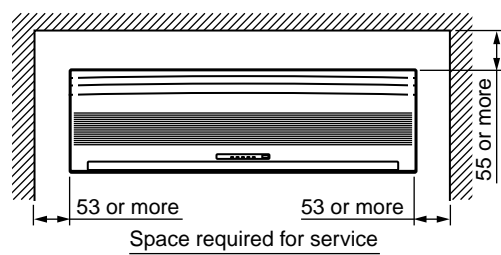
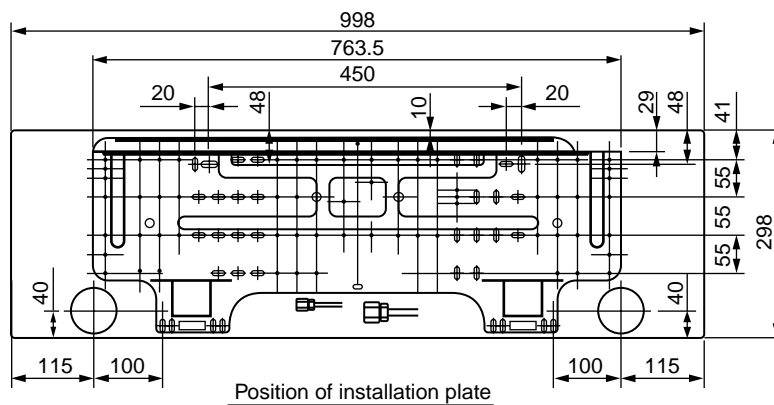
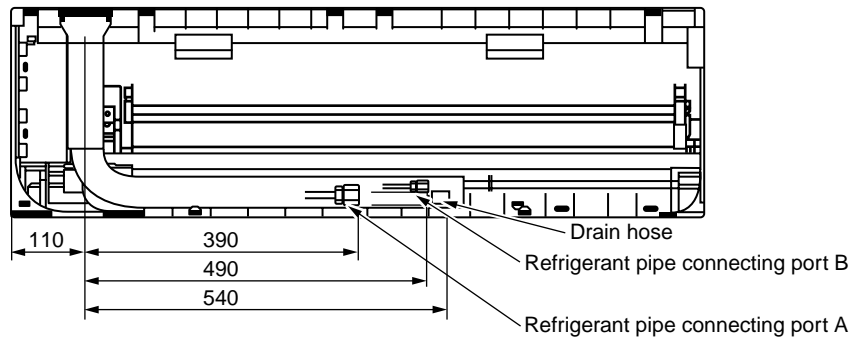

	A Liquid Side	B Gas Side
SM560	Ø6.4	Ø12.7
SM800	Ø9.5	Ø15.9

Under Ceiling/Console Type
RAV-SM560XT-E/RAV-SM800XT-E

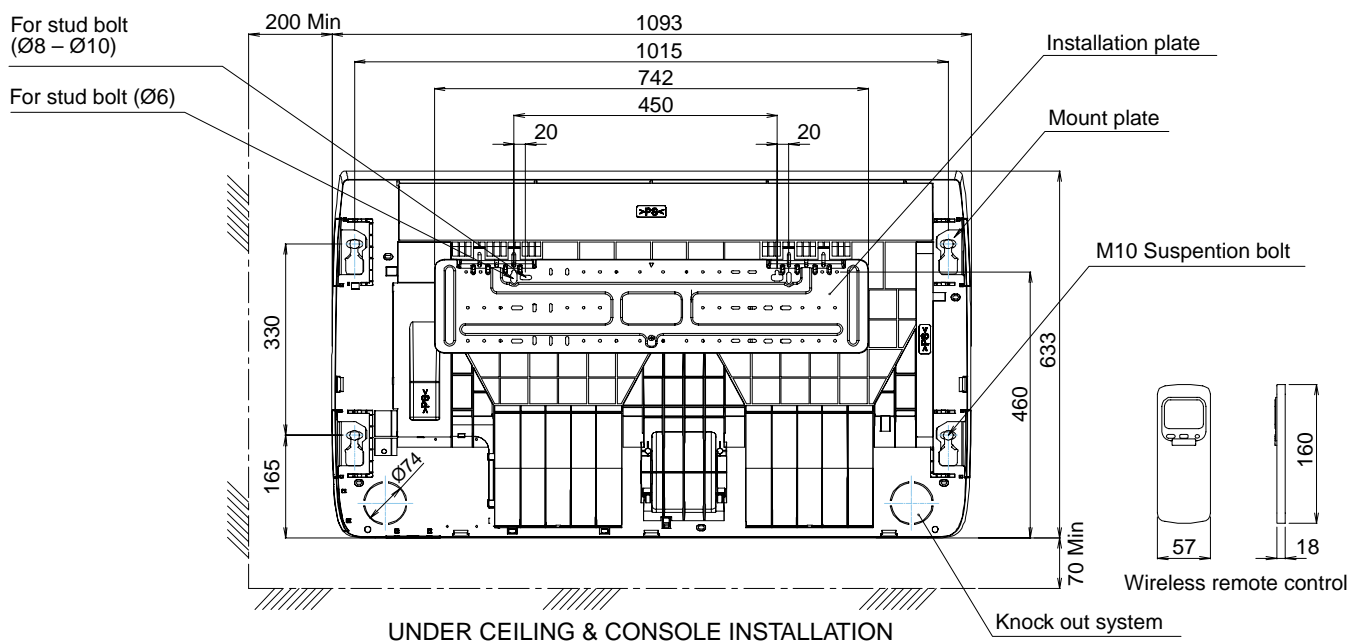
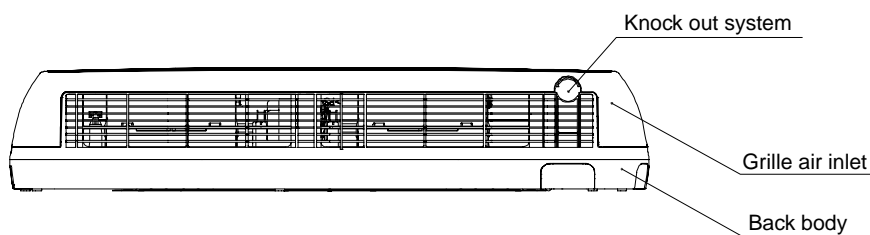
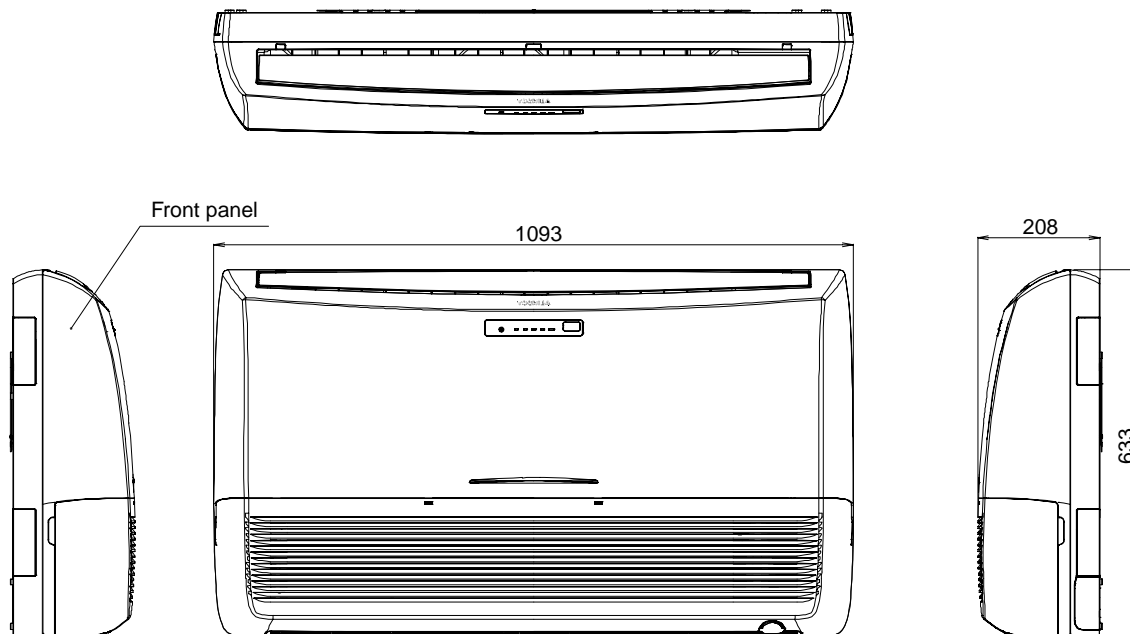

3-2. Outdoor Unit

RAV-SM560AT-E

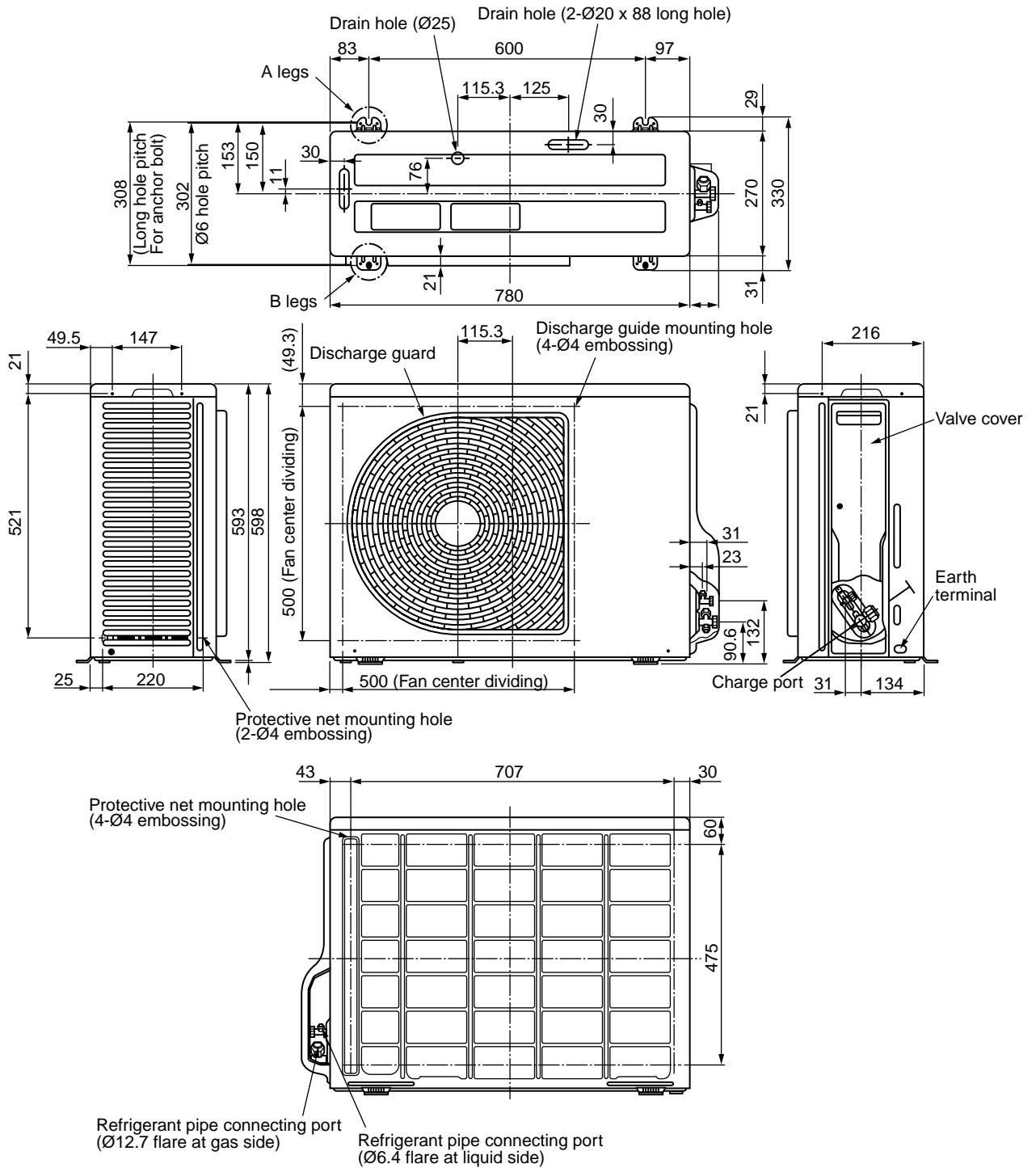

Space required for service

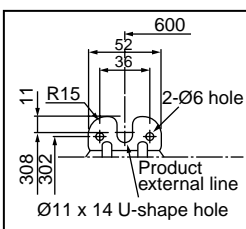

Details of A legs

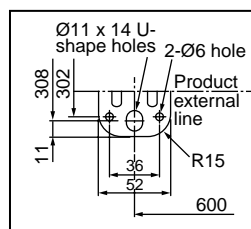

Details of B legs

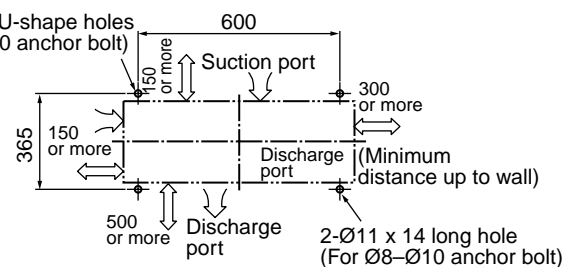

RAV-SM800AT-E

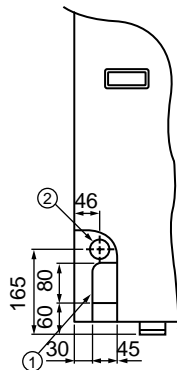
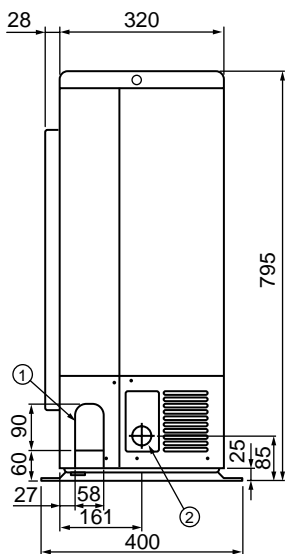
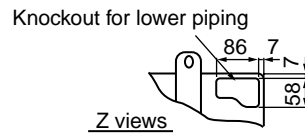
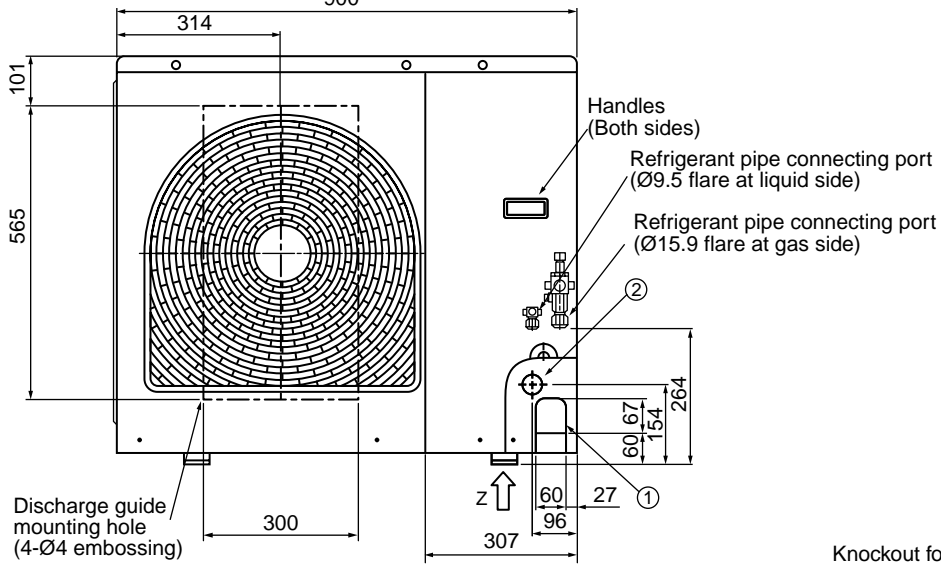
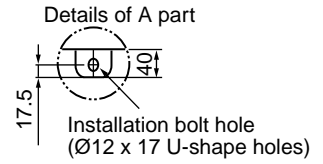
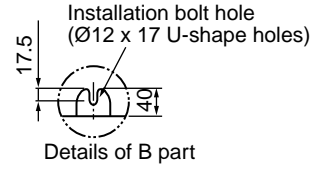
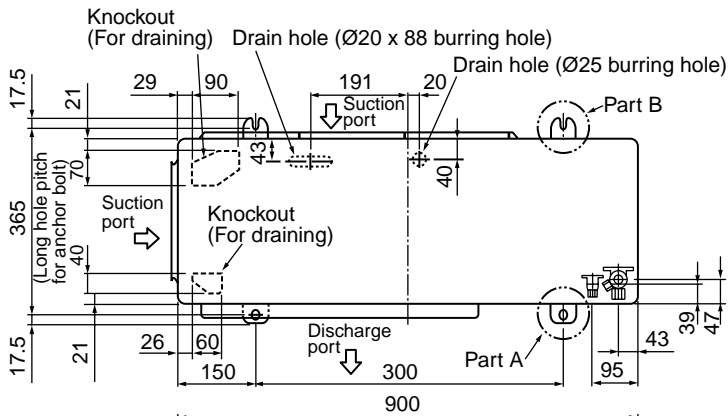

Space required for service

2-Ø12 x 17 U-shape holes
(For Ø8-Ø10 anchor bolt)

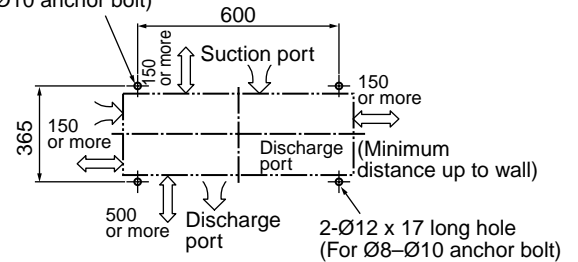

4. SYSTEMATIC REFRIGERATING CYCLE DIAGRAM

Indoor Unit/Outdoor Unit

RAV-SM560UT-E, RAV-SM560BT-E, RAV-SM560KRT-E/RAV-SM560AT-E

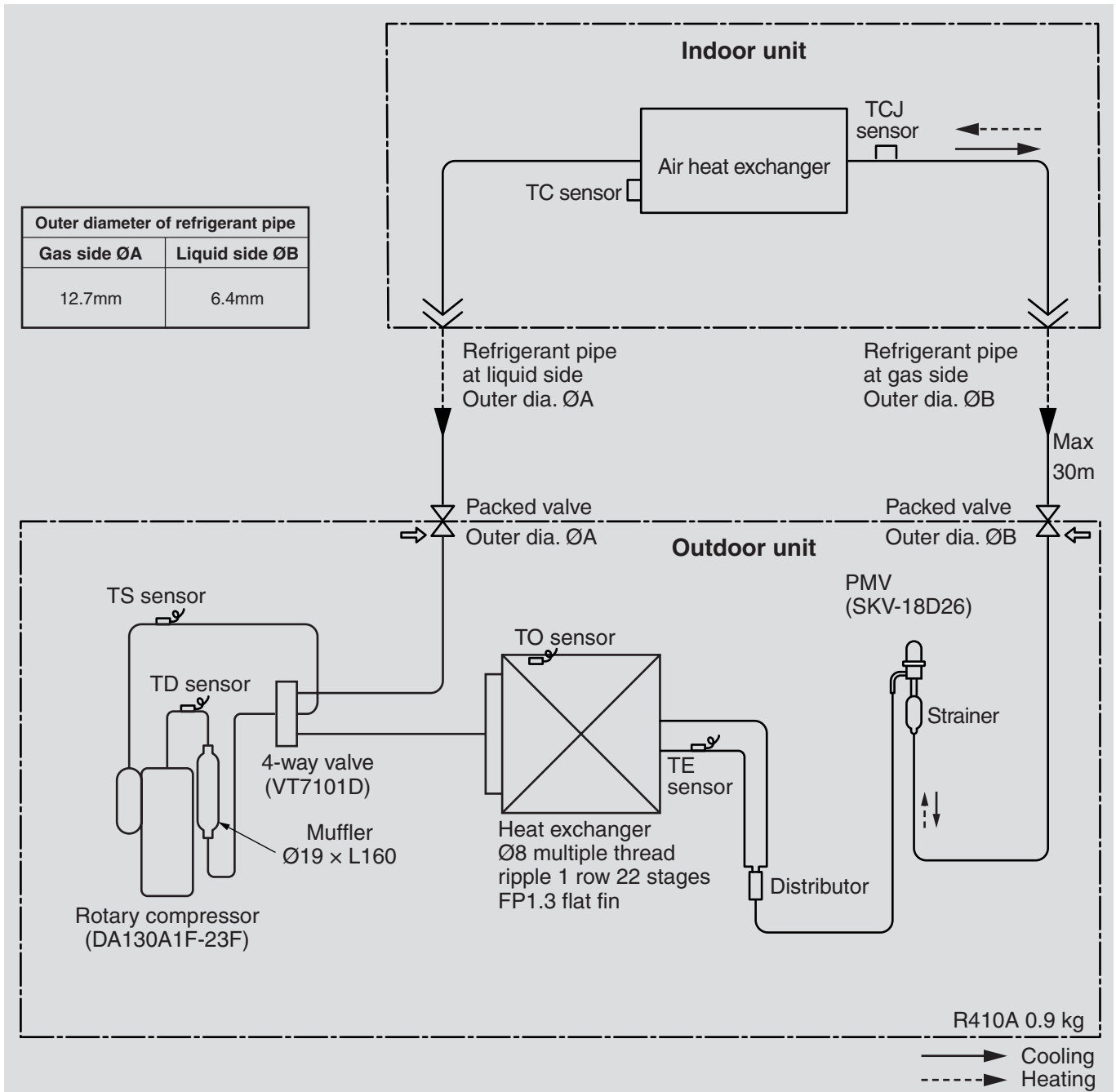

		Pressure				Pipe surface temperature (°C)				Compressor revolutions per second (rps) *	Indoor fan	Indoor/Outdoor temp. conditions (DB/WB) (°C)	
		(MPa)		(kg/cm ² G)		Discharge (TD)	Suction (TS)	Indoor heat exchanger (TC)	Outdoor heat exchanger (TE)			Indoor	Outdoor
		Pd	Ps	Pd	Ps								
Cooling	Standard	3.1	0.9	31.9	8.9	85	15	10	50	74	HIGH	27/19	35/-
	Overload	3.6	1.0	37.1	10.4	93	20	15	57	72	HIGH	32/24	43/-
	Low load	0.9	0.7	9.1	7.1	20	7	3	5	28	LOW	18/15.5	-5/-
Heating	Standard	2.3	0.6	23.6	6.2	71	1	39	3	84	HIGH	20/-	7/6
	Overload	3.3	1.2	33.2	11.8	78	20	54	19	47	LOW	30.-	24/18
	Low load	1.7	0.2	16.4	1.8	110	-20	26	-22	110	HIGH	15/-	-20/(70%)

* 4 poles are provided to this compressor.

The compressor frequency (Hz) measured with a clamp meter is 2 times of revolutions (rps) of the compressor.

Indoor Unit/Outdoor Unit
RAV-SM800UT-E, RAV-SM800BT-E, RAV-SM800KRT-E/RAV-SM800AT-E

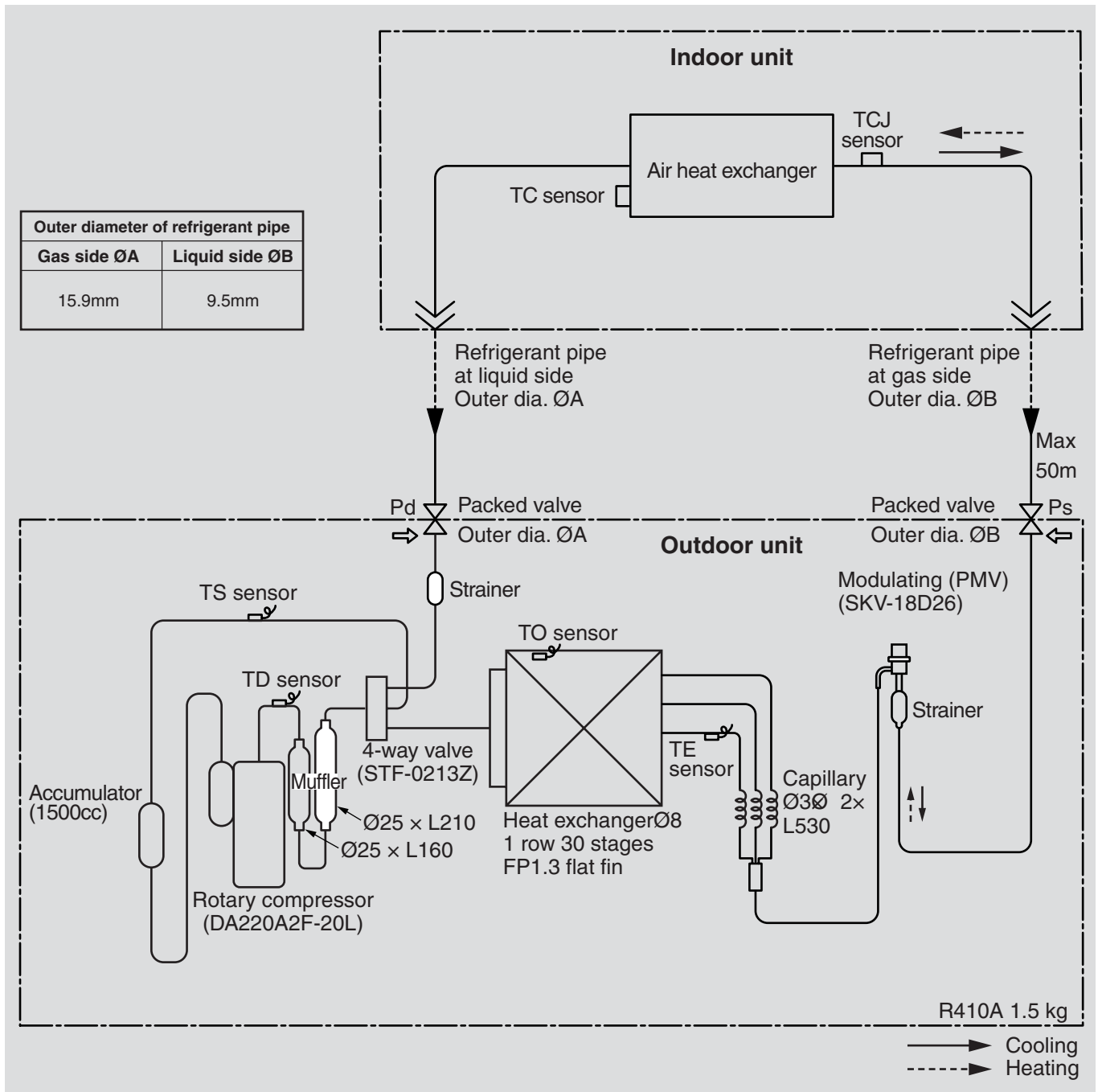

		Pressure				Pipe surface temperature (°C)				Compressor revolutions per second (rps) *	Indoor fan	Indoor/Outdoor temp. conditions (DB/WB) (°C)	
		(MPa)		(kg/cm ² G)		Discharge	Suction	Indoor heat exchanger	Outdoor heat exchanger			Indoor	Outdoor
		Pd	Ps	Pd	Ps	(TD)	(TS)	(TC)	(TE)				
Cooling	Standard	3.3	0.9	33.4	8.8	86	11	9	44	64	HIGH	27/19	35/-
	Overload	3.7	1.1	37.8	11.4	90	21	18	54	52	HIGH	32/24	43/-
	Low load	1.0	0.8	10.0	7.9	19	4	4	8	27	LOW	18/15.5	-5/-
Heating	Standard	2.5	0.6	25.8	6.3	67	6	42	2	65	HIGH	20/-	7/6
	Overload	3.4	1.1	34.7	11.5	85	23	55	16	31	LOW	30.-	24/18
	Low load	2.0	0.2	20.3	2.3	89	-16	34	-18	90	HIGH	15/-	-20/ (70%)

* 4 poles are provided to this compressor.

The compressor frequency (Hz) measured with a clamp meter is 2 times of revolutions (rps) of the compressor.

5. WIRING DIAGRAM

5-1. Indoor Unit

**4-Way Air Discharge Cassette Type
RAV-SM560UT-E/RAV-SM800UT-E**

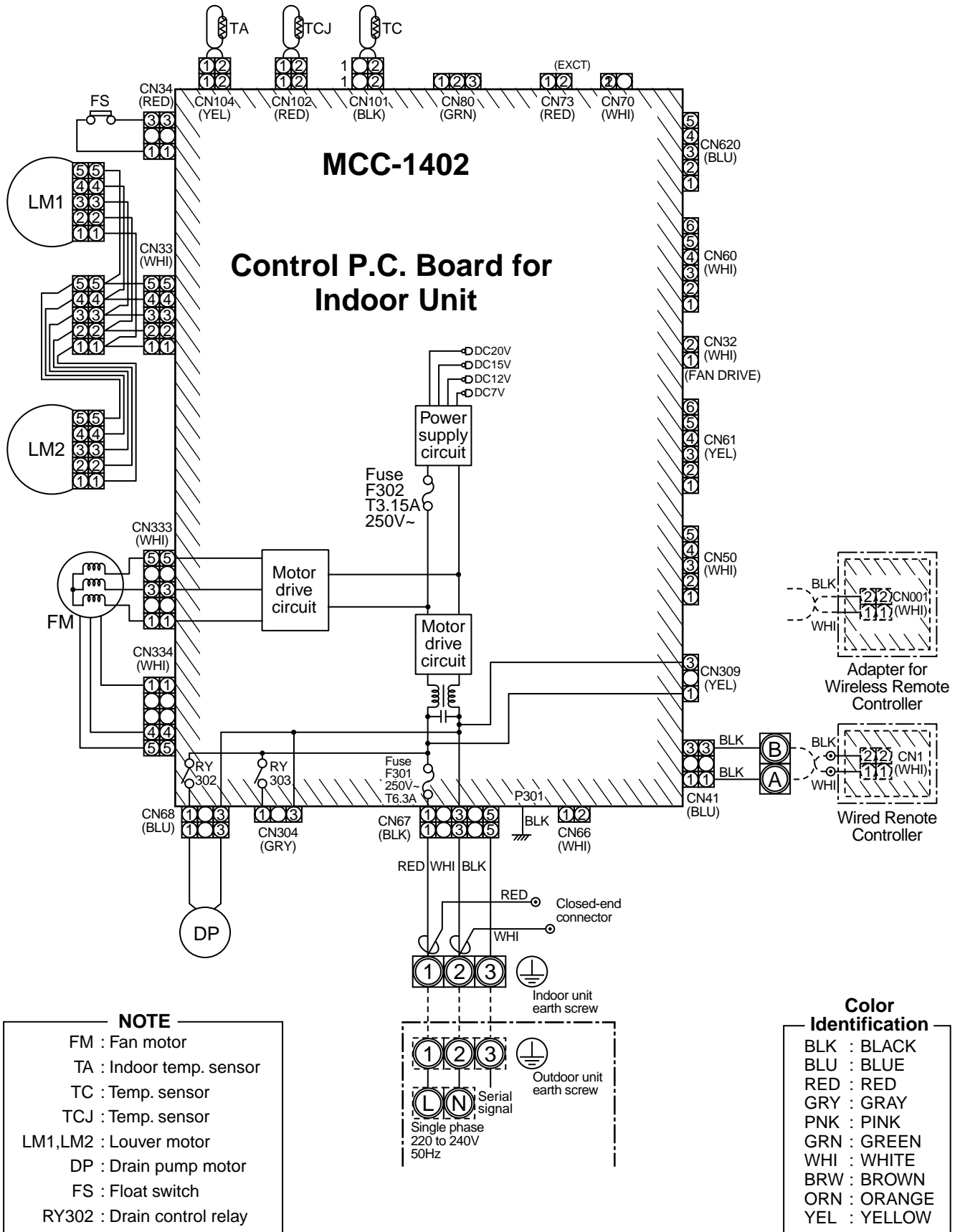

Concealed Duct Type
RAV-SM560BT-E/RAV-SM800BT-E

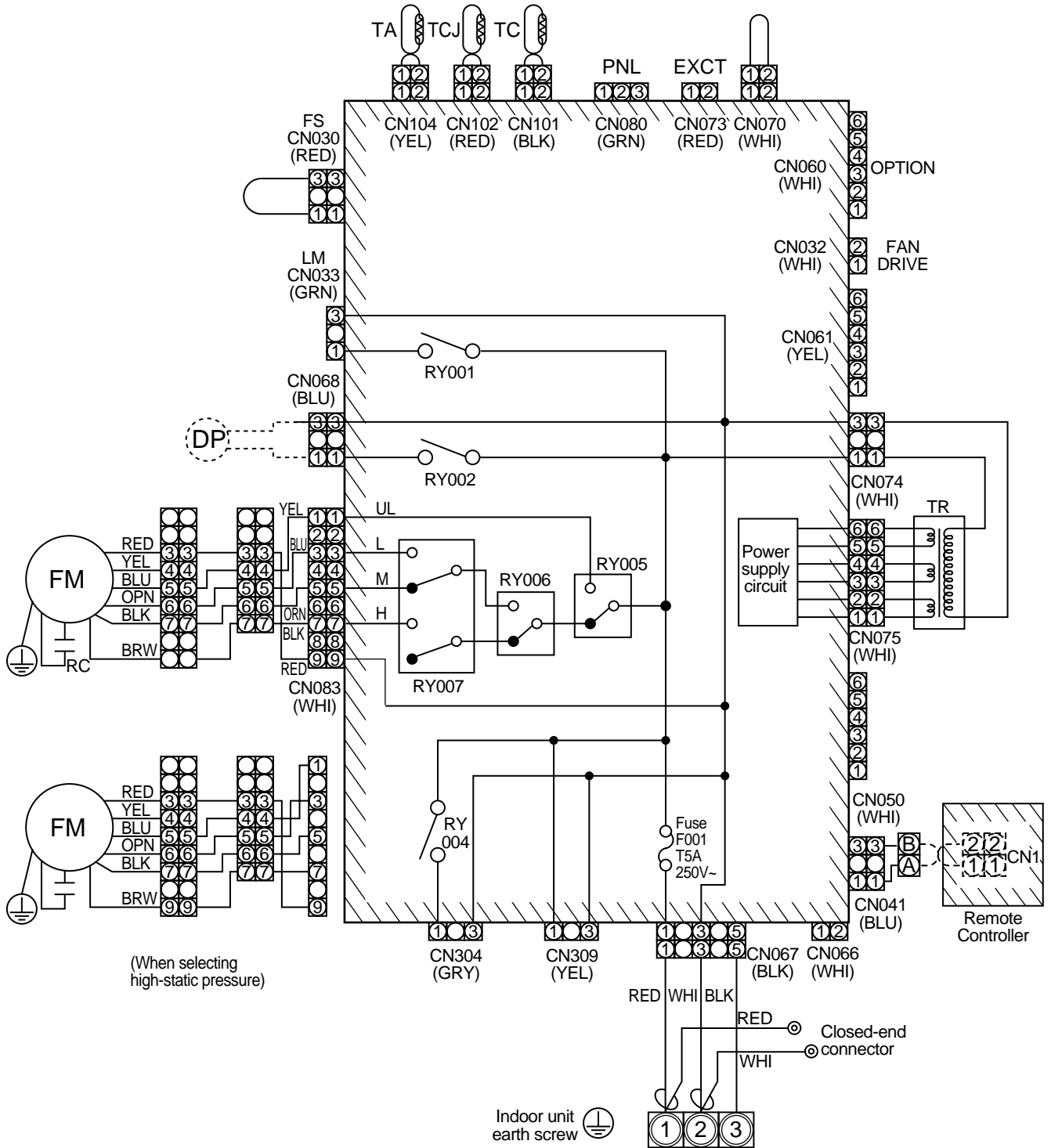

(When selecting high-static pressure)

NOTE

- FM : Fan motor
- RC : Runing capacitor
- TR : Transformer
- LM : Louver motor
- TA : Indoor temp. sensor
- TC, TCJ : Indoor heat exchanger sensor
- RY001 : Louver control relay
- RY002 : Drain control relay
- RY005~007 : Air volume control relay
- DP : Drain pump motor

Color Identification

- BLK : BLACK
- BLU : BLUE
- RED : RED
- GRY : GRAY
- PNK : PINK
- GRN : GREEN
- WHI : WHITE
- BRW : BROWN
- ORN : ORANGE
- YEL : YELLOW

High-Wall Type
RAV-SM560KRT-E/RAV-SM800KRT-E

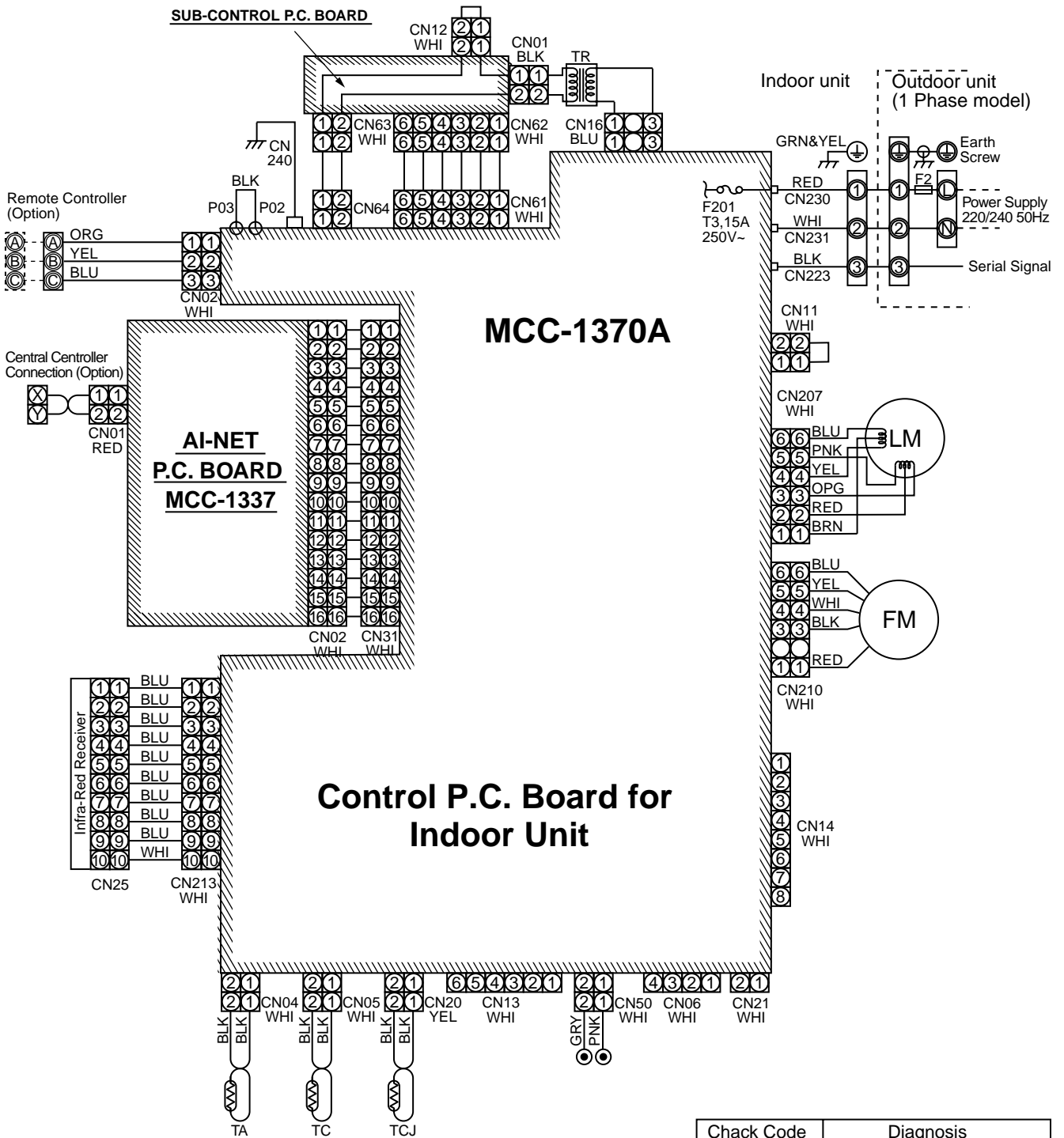

NOTE

- F : Fuse (PCB)
- FM : Fan motor
- LM : Louver motor
- TA : Temperature sensor
- TC : Temperature sensor
- TCJ : Temperature sensor
- TR : Transformer
- O/D : Outdoor
- R/C : Remote Controller

LED Detail		
D05	Orange	O/D Serial Signal Input
D02	Green	O/D Serial Signal Output
D13	Orange	R/C Serial Signal Input
D11	Green	R/C Serial Signal Output

Check Code	Diagnosis
04	Serial Signal Error
08	4-Way Valve Error
09	I/D Heart Exchange Error
0C	TA Sensor Error
0d	TC Sensor Error
0F	TCJ Sensor Error
11	Indoor Fan Error
12	Indoor unit Error
97	LAN Comms Circuit Error
98	LAN Address Setting
99	R/C Mis-Wiring

RAV-SM560XT-E/RAV-SM800XT-E

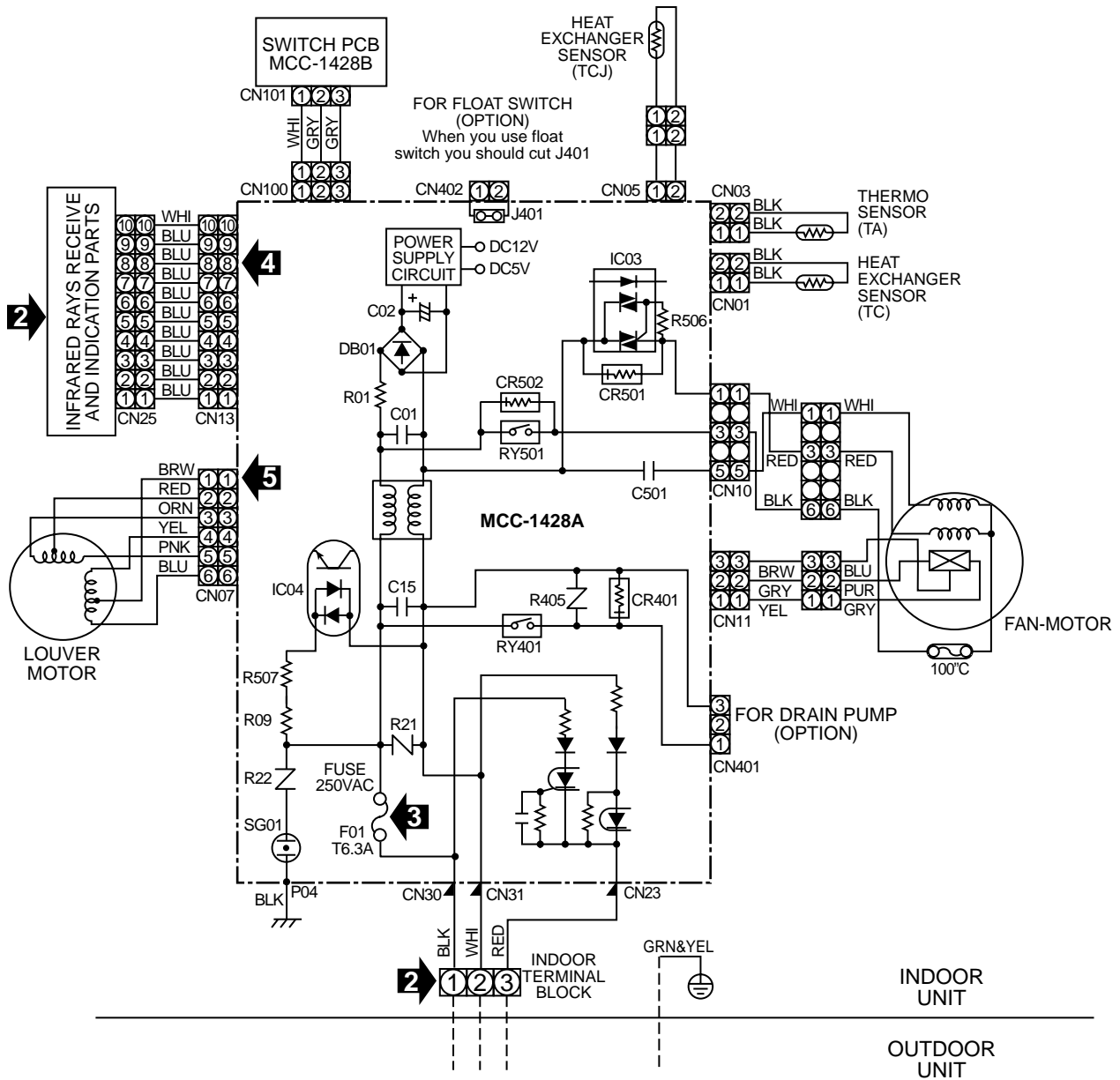

SIMPLE CHECK POINTS FOR DIAGNOSING FAULTS

Check items	Diagnosis result	Color Identification BRW : BROWN RED : RED WHI : WHITE YEL : YELLOW BLU : BLUE BLK : BLACK GRY : GRAY PNK : PINK ORN : ORANGE GRN&YEL : GREEN&YELLOW GRN : GREEN PUR : PURPLE
1 OPERATION indicator	Check to see if OPERATION indicator goes on and off when the main switch or breaker is turned on.	
2 Terminal block	Check the power supply voltage between ① - ② (Refer to the name plate.) Check the fluctuate voltage between ② - ③ (DC15 to 60V)	
3 Fuse 6.3A	Check to see if the fuse blows out. (Check the varistor. : R22, R21)	
4 DC 5V	Check the voltage at the No.8 pin on CN13 connector of the infrared receiver. (Check the transformer and the power supply circuit of the rated voltage.)	
5 DC 12V	Check the voltage at the brown lead of the louver motor. (Check the transformer and the power supply circuit of the rated voltage.)	

5-2. Outdoor Unit

RAV-SM560AT-E

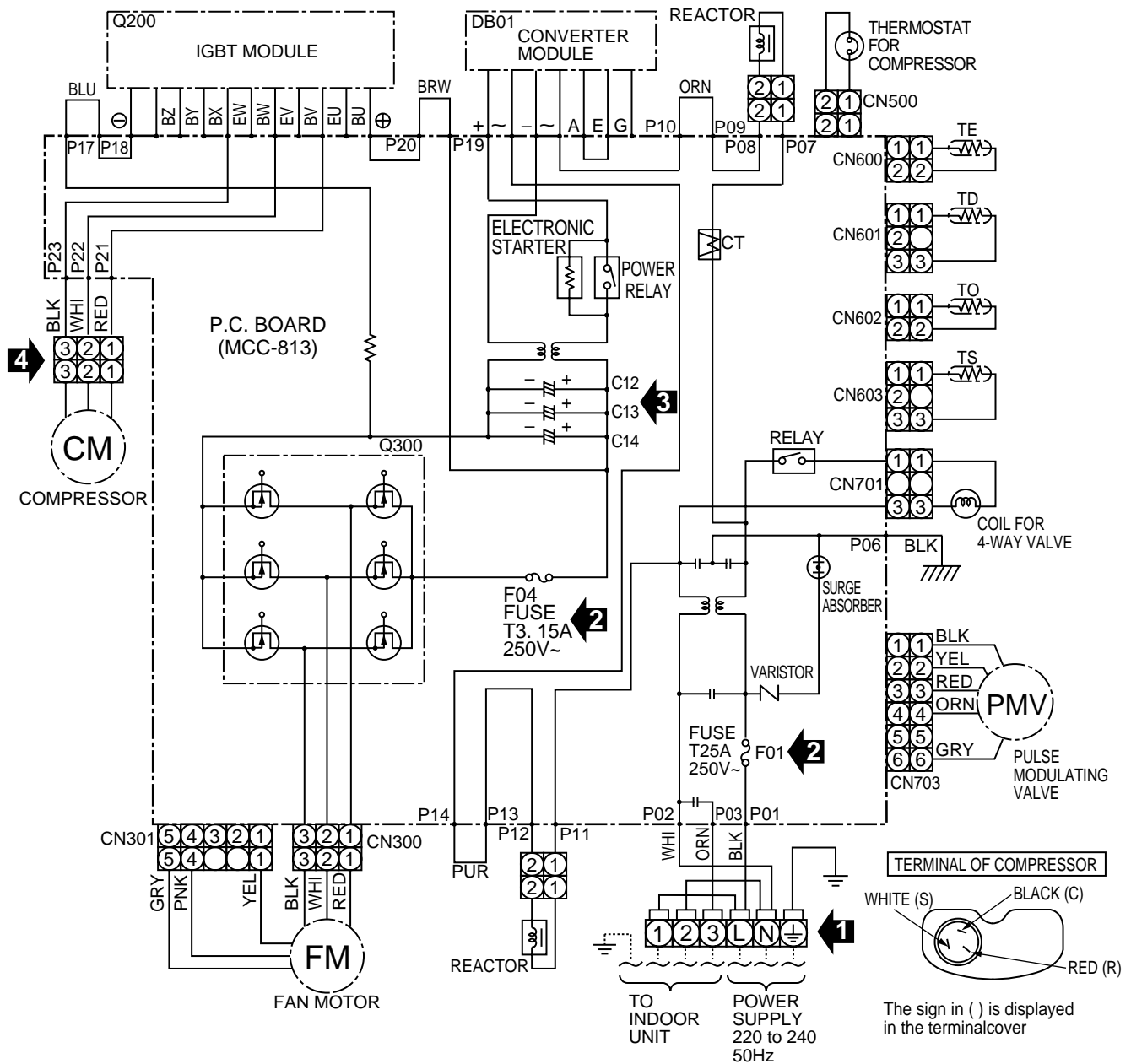

SIMPLE CHECK POINTS FOR DIAGNOSING FAULTS

Check items	Diagnosis result
1	TERMINAL BLOCK There is no supply voltage (AC220 to 240V) between ① - ④, ① - ② → Power supply and connecting cable check There is no voltage (DC15 to 25V) ② - ③
2	FUSE T25A 250V to fuse (F01) blown → Converter module (DB01) and electrolytic capacitor (C12 to C14) check T3.15A 250V to fuse (F04) blown → IGBT module (Q200) check Fan motor check
3	ELECTROLYTIC CAPACITOR VOLTAGE (C12, C13, C14) DC320V not available between ⊕ ⊖ terminal of electrolytic capacitor → T25A fuse (F01) check → P.C. board and converter module (DB01) check
4	INVERTER OUTPUT (Inverter and compressor connector out of position) (Please confirm within six minutes after instructing in the drive.) Voltage between each line of inverter side → IGBT module and P.C. board check connector pins are not equal.

Color Identification

BLK : BLACK	WHI : WHITE
BLU : BLUE	BRW : BROWN
RED : RED	ORN : ORANGE
GRY : GRAY	YEL : YELLOW
PNK : PINK	PUR : PURPLE
GRN : GREEN	

NOTE

CM	: Compressor
PMV	: Pulse modulating valve
FM	: Fan motor
TE	: Heat exchanger Temp. Sensor
TD	: Discharge Temp. Sensor
TO	: Outdoor Temp. Sensor
TS	: Suction Temp. Sensor
IGBT	: Insulated Gate Bipolar Transistor
DB01	: Converter module
CT	: Current Transformer
Q300	: Fan motor driver module

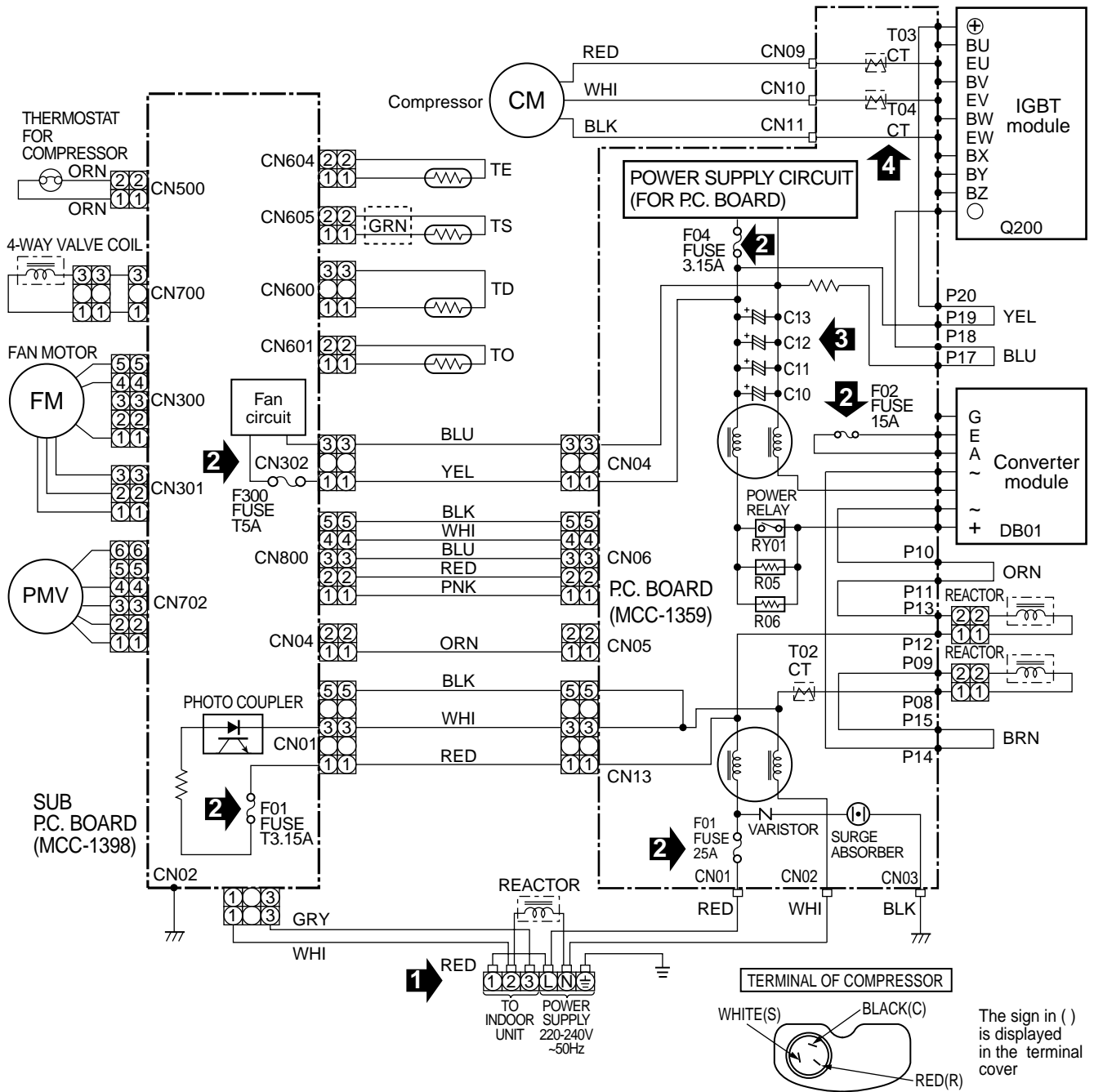

SIMPLE CHECK POINTS FOR DIAGNOSING FAULTS

Check items	Diagnosis result
1	<p>TERMINAL BLOCK There is no supply voltage (AC220 to 240V) between ① - (N), ① - ② → Connecting cable check There is no voltage (DC15 to 25V) ② - ③</p>
2	<p>FUSE 25A fuse (F01) blown, 15A fuse (F02) blown 3.15A fuse (F04) blown, T5A fuse (F300) blown (SUB P.C. board) T3.15A fuse (F01) blown (SUB P.C. board) → Converter module (DB01) and electrolytic capacitor (C10 to C13) check IGBT module (Q200) check, Fan motor check SUB P.C. board check</p>
3	<p>ELECTROLYTIC CAPACITOR VOLTAGE (C10, C11, C12, C13) DC320V not available between ⊕○ terminal of electrolytic capacitor → 25A fuse (F01) check P.C. board and coverter module (DB01) check</p>
4	<p>INVERTER OUTPUT (CN09, CN10, CN11) (Please confirm within six minutes after instructing in the drive.) Voltage between each line of inverter side and connector pins are not equal. → IGBT module and P.C. board check</p>

Color Identification

BLK : BLACK	WHI : WHITE
BLU : BLUE	BRN : BROWN
RED : RED	ORN : ORANGE
GRY : GRAY	YEL : YELLOW
PNK : PINK	PUR : PURPLE
GRN : GREEN	

6. SPECIFICATIONS OF ELECTRICAL PARTS

6-1. Indoor Unit

4-Way Air Discharge Cassette Type RAV-SM560UT-E/RAV-SM800UT-E

No.	Parts name	Type	Specifications
1	Fan motor (for indoor)	SWF-230-60-1	Output (Rated) 60 W, 220–240 V
2	Thermo. sensor (TA-sensor)	155 mm	10 kΩ at 25°C
3	Heat exchanger sensor (TCJ-sensor)	Ø6 mm, 1200 mm	10 kΩ at 25°C
4	Heat exchanger sensor (TC-sensor)	Ø6 mm, 1200 mm	10 kΩ at 25°C
5	Float switch	FS-0218-106	
6	Drain pump motor	ADP-1406	

Concealed Duct Type RAV-SM560BT-E/RAV-SM800BT-E

No.	Parts name	Type	Specifications
1	Fan motor (RAV-SM800BT-E)	STF-230-80-4C	Output (Rated) 80 W, 220–240 V, 4P
2	Fan motor (RAV-SM560BT-E)	STF-220-80-4C	Output (Rated) 80 W, 220–240 V, 4P
3	Capacitor (RAV-SM800BT-E)	EAG40M805UF1	400WV, 5μF
4	Capacitor (RAV-SM560BT-E)	CMPS400-4.0	400WV, 4.0μF
5	Thermo. sensor (TA-sensor)	818 mm	10 kΩ at 25°C
6	Heat exchanger sensor (TC-sensor)	Ø6 mm, 1200 mm	10 kΩ at 25°C
7	Heat exchanger sensor (TCJ-sensor)	Ø6 mm, 1200 mm	10 kΩ at 25°C

High-Wall Type RAV-SM560KRT-E/RAV-SM800KRT-E

No.	Parts name	Type	Specifications
1	Fan motor (for indoor)	ICF340-30-1	Output (Rated) 30 W, 220–240 V
2	Grille motor	MP35EA12	
3	Thermo. sensor (TA-sensor)	268 mm	10 kΩ at 25°C
4	Heat exchanger sensor (TC-sensor)	Ø6 mm, 400 mm	10 kΩ at 25°C
5	Heat exchanger sensor (TCJ-sensor)	Ø6 mm, 400 mm	

RAV-SM560XT-E/RAV-SM800XT-E

No.	Parts name	Type	Specifications
1	Fan motor (for indoor)	AFP-220-50-4A	Output (Rated) 50 W, 220–240 V
2	Grille motor	MP35EA	DC 12 V
3	Thermo. sensor (TA-sensor)	mm	10 kΩ at 25°C
4	Heat exchanger sensor (TC-sensor)	Ø6 mm, mm	10 kΩ at 25°C
5	Heat exchanger sensor (TCJ-sensor)	Ø6 mm, mm	

6-2. Outdoor Unit

RAV-SM560AT-E

No.	Parts name	Type	Specifications
1	Fan motor	ICF-140-43-1	Output (Rated) 40 W
2	Compressor	DA130A1F-23F	3 phase, 4P, 1100 W
3	Reactor	CH-57	10 mH, 16A
4	Outdoor temp. sensor (To-sensor)	—	10 kΩ at 25°C
5	Heat exchanger sensor (Te-sensor)	—	10 kΩ at 25°C
6	Suction temp. sensor (Ts-sensor)	—	10 kΩ at 25°C
7	Discharge temp. sensor (Td-sensor)	—	50 kΩ at 25°C
8	Fuse (Switching power (Protect))		T3.15 A, AC 250 V
9	Fuse (Inverter, input (Current protect))		25 A, AC 250 V
10	4-way valve solenoid coil	STF-0108G	
11	Compressor thermo. (Protection)	US-622	ON : 90 ± 5°C, OFF : 125 ± 4°C

RAV-SM800AT-E

No.	Parts name	Type	Specifications
1	Fan motor	ICF-140-63-1	Output (Rated) 63 W, 220–240 V
2	Compressor	DA220A2F-20L	3 phase, 4P, 1600 W
3	Reactor	CH-47	8 mH, 16 A
4	Outdoor temp. sensor (To-sensor)	—	10 kΩ at 25°C
5	Heat exchanger sensor (Te-sensor)	—	10 kΩ at 25°C
6	Suction temp. sensor (Ts-sensor)	—	10 kΩ at 25°C
7	Discharge temp. sensor (Td-sensor)	—	50 kΩ at 25°C
8	Fuse (Switching power (Protect))		T3.15 A, AC 250 V
9	Fuse (Inverter, input (Current protect))		25 A, AC 250 V
10	4-way valve solenoid coil	DKV-M0ZS743B0	
11	Compressor thermo. (Protection)		ON : 90 ± 5°C, OFF : 125 ± 4°C

6-3. Accessory Separate Sold Parts

RBC-U21PG (W) E (Ceiling panel)

No.	Parts name	Type	Specifications
1	Motor-louver	MP24GA	DC 12 V
2			

TCB-DP11E (Drain up pump)

No.	Parts name	Type	Specifications
1	Pump-drain	PJD-05230TF-1	AC 220–240 V
2			

7. REFRIGERANT R410A

This air conditioner adopts the new refrigerant HFC (R410A) which does not damage the ozone layer.

The working pressure of the new refrigerant R410A is 1.6 times higher than conventional refrigerant (R22). The refrigerating oil is also changed in accordance with change of refrigerant, so be careful that water, dust, and existing refrigerant or refrigerating oil are not entered in the refrigerant cycle of the air conditioner using the new refrigerant during installation work or servicing time.

The next section describes the precautions for air conditioner using the new refrigerant. Conforming to contents of the next section together with the general cautions included in this manual, perform the correct and safe work.

7-1. Safety During Installation/Serviceing

As R410A's pressure is about 1.6 times higher than that of R22, improper installation/serviceing may cause a serious trouble. By using tools and materials exclusive for R410A, it is necessary to carry out installation/serviceing safely while taking the following precautions into consideration.

- (1) Never use refrigerant other than R410A in an air conditioner which is designed to operate with R410A.

If other refrigerant than R410A is mixed, pressure in the refrigeration cycle becomes abnormally high, and it may cause personal injury, etc. by a rupture.

- (2) Confirm the used refrigerant name, and use tools and materials exclusive for the refrigerant R410A.

The refrigerant name R410A is indicated on the visible place of the outdoor unit of the air conditioner using R410A as refrigerant. To prevent mischarging, the diameter of the service port differs from that of R22.

- (3) If a refrigeration gas leakage occurs during installation/serviceing, be sure to ventilate fully.
If the refrigerant gas comes into contact with fire, a poisonous gas may occur.
- (4) When installing or removing an air conditioner, do not allow air or moisture to remain in the refrigeration cycle. Otherwise, pressure in the refrigeration cycle may become abnormally high so that a rupture or personal injury may be caused.
- (5) After completion of installation work, check to make sure that there is no refrigeration gas leakage.

If the refrigerant gas leaks into the room, coming into contact with fire in the fan-driven heater, space heater, etc., a poisonous gas may occur.

- (6) When an air conditioning system charged with a large volume of refrigerant is installed in a small room, it is necessary to exercise care so that, even when refrigerant leaks, its concentration does not exceed the marginal level.

If the refrigerant gas leakage occurs and its concentration exceeds the marginal level, an oxygen starvation accident may result.

- (7) Be sure to carry out installation or removal according to the installation manual.
Improper installation may cause refrigeration trouble, water leakage, electric shock, fire, etc.
- (8) Unauthorized modifications to the air conditioner may be dangerous. If a breakdown occurs please call a qualified air conditioner technician or electrician.

Improper repair's may result in water leakage, electric shock and fire, etc.

7-2. Refrigerant Piping Installation

7-2-1. Piping Materials and Joints Used

For the refrigerant piping installation, copper pipes and joints are mainly used. Copper pipes and joints suitable for the refrigerant must be chosen and installed. Furthermore, it is necessary to use clean copper pipes and joints whose interior surfaces are less affected by contaminants.

- (1) Copper Pipes

It is necessary to use seamless copper pipes which are made of either copper or copper alloy and it is desirable that the amount of residual oil is less than 40 mg/10 m. Do not use copper pipes having a collapsed, deformed or discolored portion (especially on the interior surface). Otherwise, the expansion valve or capillary tube may become blocked with contaminants.

As an air conditioner using R410A incurs pressure higher than when using R22, it is necessary to choose adequate materials.

Thicknesses of copper pipes used with R410A are as shown in Table 7-2-1. Never use copper pipes thinner than 0.8 mm even when it is available on the market.

Table 7-2-1 Thicknesses of annealed copper pipes

		Thickness (mm)	
Nominal diameter	Outer diameter (mm)	R410A	R22
1/4	6.35	0.80	0.80
3/8	9.52	0.80	0.80
1/2	12.70	0.80	0.80
5/8	15.88	1.00	1.00

(2) Joints

For copper pipes, flare joints or socket joints are used. Prior to use, be sure to remove all contaminants.

a) Flare Joints

Flare joints used to connect the copper pipes cannot be used for pipings whose outer diameter exceeds 20 mm. In such a case, socket joints can be used.

Sizes of flare pipe ends, flare joint ends and flare nuts are as shown in Tables 7-2-3 to 7-2-6 below.

b) Socket Joints

Socket joints are such that they are brazed for connections, and used mainly for thick pipings whose diameter is larger than 20 mm. Thicknesses of socket joints are as shown in Table 7-2-2.

Table 7-2-2 Minimum thicknesses of socket joints

Nominal diameter	Reference outer diameter of copper pipe jointed (mm)	Minimum joint thickness (mm)
1/4	6.35	0.50
3/8	9.52	0.60
1/2	12.70	0.70
5/8	15.88	0.80

7-2-2. Processing of Piping Materials

When performing the refrigerant piping installation, care should be taken to ensure that water or dust does not enter the pipe interior, that no other oil other than lubricating oils used in the installed air conditioner is used, and that refrigerant does not leak. When using lubricating oils in the piping processing, use such lubricating oils whose water content has been removed. When stored, be sure to seal the container with an airtight cap or any other cover.

(1) Flare Processing Procedures and Precautions

a) Cutting the Pipe

By means of a pipe cutter, slowly cut the pipe so that it is not deformed.

b) Removing Burrs and Chips

If the flared section has chips or burrs, refrigerant leakage may occur. Carefully remove all burrs and clean the cut surface before installation.

c) Insertion of Flare Nut

d) Flare Processing

Make certain that a clamp bar and copper pipe have been cleaned.

By means of the clamp bar, perform the flare processing correctly.

Use either a flare tool for R410A or conventional flare tool.

Flare processing dimensions differ according to the type of flare tool. When using a conventional flare tool, be sure to secure "dimension A" by using a gauge for size adjustment.

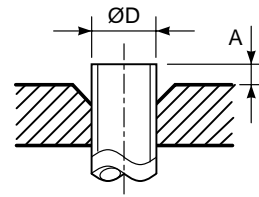

Fig. 7-2-1 Flare processing dimensions

Table 7-2-3 Dimensions related to flare processing for R410A

Nominal diameter	Outer diameter (mm)	Thickness (mm)	A (mm)		
			Flare tool for R410A clutch type	Conventional flare tool	
				Clutch type	Wing nut type
1/4	6.35	0.8	0 to 0.5	1.0 to 1.5	1.5 to 2.0
3/8	9.52	0.8	0 to 0.5	1.0 to 1.5	1.5 to 2.0
1/2	12.70	0.8	0 to 0.5	1.0 to 1.5	2.0 to 2.5
5/8	15.88	1.0	0 to 0.5	1.0 to 1.5	2.0 to 2.5

Table 7-2-4 Dimensions related to flare processing for R22

Nominal diameter	Outer diameter (mm)	Thickness (mm)	A (mm)		
			Flare tool for R22 clutch type	Conventional flare tool	
				Clutch type	Wing nut type
1/4	6.35	0.8	0 to 0.5	0.5 to 1.0	1.0 to 1.5
3/8	9.52	0.8	0 to 0.5	0.5 to 1.0	1.0 to 1.5
1/2	12.70	0.8	0 to 0.5	0.5 to 1.0	1.5 to 2.0
5/8	15.88	1.0	0 to 0.5	0.5 to 1.0	1.5 to 2.0

Table 7-2-5 Flare and flare nut dimensions for R410A

Nominal diameter	Outer diameter (mm)	Thickness (mm)	Dimension (mm)				Flare nut width (mm)
			A	B	C	D	
1/4	6.35	0.8	9.1	9.2	6.5	13	17
3/8	9.52	0.8	13.2	13.5	9.7	20	22
1/2	12.70	0.8	16.6	16.0	12.9	23	26
5/8	15.88	1.0	19.7	19.0	16.0	25	29

Table 7-2-6 Flare and flare nut dimensions for R22

Nominal diameter	Outer diameter (mm)	Thickness (mm)	Dimension (mm)				Flare nut width (mm)
			A	B	C	D	
1/4	6.35	0.8	9.0	9.2	6.5	13	17
3/8	9.52	0.8	13.0	13.5	9.7	20	22
1/2	12.70	0.8	16.2	16.0	12.9	20	24
5/8	15.88	1.0	19.4	19.0	16.0	23	27
3/4	19.05	1.0	23.3	24.0	19.2	34	36

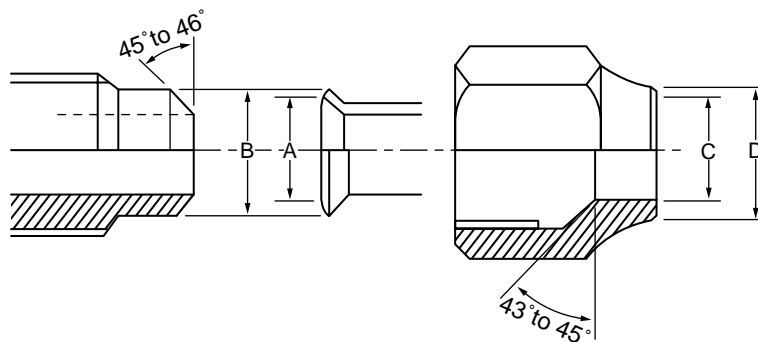

Fig. 7-2-2 Relations between flare nut and flare seal surface

(2) Flare Connecting Procedures and Precautions

- Make sure that the flare and union portions do not have any scar or dust, etc.
- Correctly align the processed flare surface with the union axis.
- Tighten the flare with designated torque by means of a torque wrench. The tightening torque for R410A is the same as that for conventional R22. Incidentally, when the torque is weak, the gas leakage may occur.

When it is strong, the flare nut may crack and may be made non-removable. When choosing the tightening torque, comply with values designated by manufacturers. Table 7-2-7 shows reference values.

NOTE:

When applying oil to the flare surface, be sure to use oil designated by the manufacturer. If any other oil is used, the lubricating oils may deteriorate and cause the compressor to burn out.

Table 7-2-7 Tightening torque of flare for R410A [Reference values]

Nominal diameter	Outer diameter (mm)	Tightening torque N•m (kgf•cm)	Tightening torque of torque wrenches available on the market N•m (kgf•cm)
1/4	6.35	14 to 18 (140 to 180)	16 (160), 18 (180)
3/8	9.52	33 to 42 (330 to 420)	42 (420)
1/2	12.70	50 to 62 (500 to 620)	55 (550)
5/8	15.88	63 to 77 (630 to 770)	65 (650)

7-3. Tools

7-3-1. Required Tools

The service port diameter of packed valve of the outdoor unit in the air conditioner using R410A is changed to prevent mixing of other refrigerant. To reinforce the pressure-resisting strength, flare processing dimensions and opposite side dimension of flare nut (For Ø12.7 copper pipe) of the refrigerant piping are lengthened.

The used refrigerating oil is changed, and mixing of oil may cause a trouble such as generation of sludge, clogging of capillary, etc. Accordingly, the tools to be used are classified into the following three types.

- (1) Tools exclusive for R410A (Those which cannot be used for conventional refrigerant (R22))
- (2) Tools exclusive for R410A, but can be also used for conventional refrigerant (R22)
- (3) Tools commonly used for R410A and for conventional refrigerant (R22)

The table below shows the tools exclusive for R410A and their interchangeability.

Tools exclusive for R410A (The following tools for R410A are required.)

Tools whose specifications are changed for R410A and their interchangeability

No.	Used tool	Usage	R410A air conditioner installation		Conventional air conditioner installation
			Existence of new equipment for R410A	Whether conven- tional equipment can be used	Whether new equipment can be used with conventional refrigerant
①	Flare tool	Pipe flaring	Yes	*(Note 1)	○
②	Copper pipe gauge for adjusting projection margin	Flaring by conventional flare tool	Yes	*(Note 1)	*(Note 1)
③	Torque wrench	Connection of flare nut	Yes	×	×
④	Gauge manifold	Evacuating, refrigerant charge, run check, etc.	Yes	×	×
⑤	Charge hose				
⑥	Vacuum pump adapter	Vacuum evacuating	Yes	×	○
⑦	Electronic balance for refrigerant charging	Refrigerant charge	Yes	×	○
⑧	Refrigerant cylinder	Refrigerant charge	Yes	×	×
⑨	Leakage detector	Gas leakage check	Yes	×	○
⑩	Charging cylinder	Refrigerant charge	(Note 2)	×	×

(Note 1) When flaring is carried out for R410A using the conventional flare tools, adjustment of projection margin is necessary. For this adjustment, a copper pipe gauge, etc. are necessary.

(Note 2) Charging cylinder for R410A is being currently developed.

General tools (Conventional tools can be used.)

In addition to the above exclusive tools, the following equipments which serve also for R22 are necessary as the general tools.

- | | | |
|---|------------------------------|--|
| (1) Vacuum pump
Use vacuum pump by
attaching vacuum pump adapter. | (4) Reamer | (9) Hole core drill (Ø65) |
| (2) Torque wrench | (5) Pipe bender | (10) Hexagon wrench
(Opposite side 4mm) |
| (3) Pipe cutter | (6) Level vial | (11) Tape measure |
| | (7) Screwdriver (+, -) | (12) Metal saw |
| | (8) Spanner or Monkey wrench | |

Also prepare the following equipments for other installation method and run check.

- | | |
|-----------------|----------------------------------|
| (1) Clamp meter | (3) Insulation resistance tester |
| (2) Thermometer | (4) Electro-scope |

7-4. Recharging of Refrigerant

When it is necessary to recharge refrigerant, charge the specified amount of new refrigerant according to the following steps.

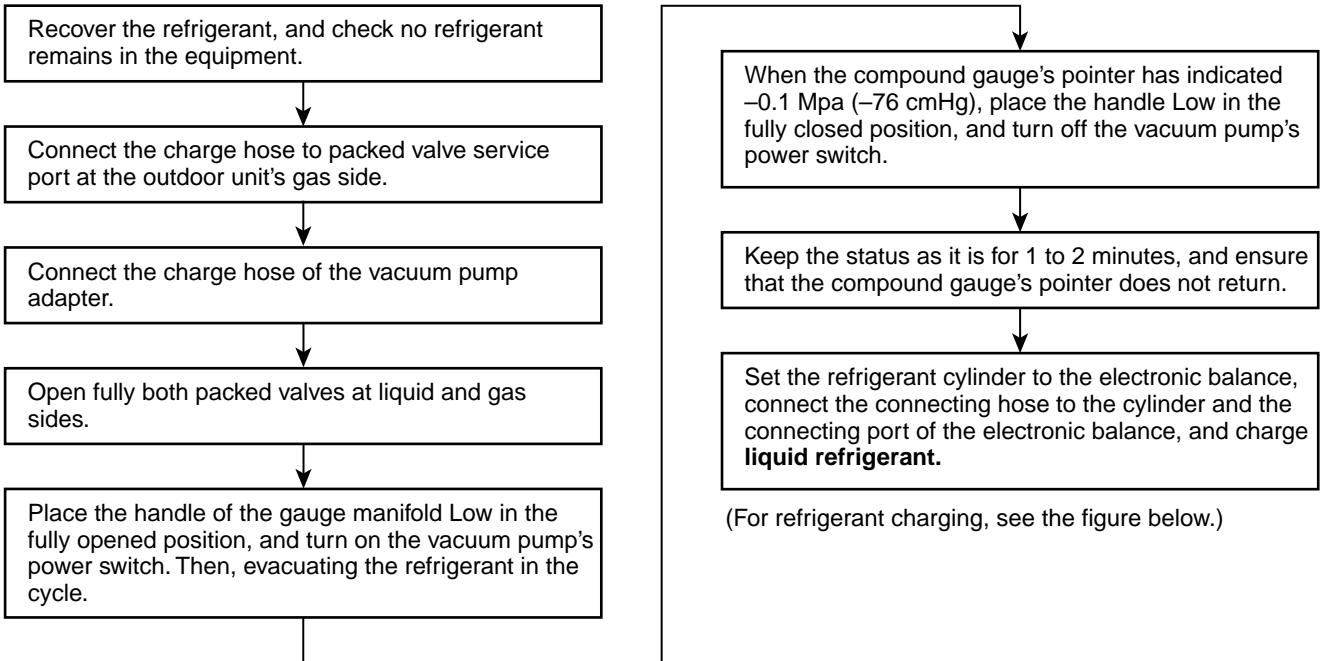

- ① Never charge refrigerant exceeding the specified amount.
- ② If the specified amount of refrigerant cannot be charged, charge refrigerant **bit by bit** in COOL mode.
- ③ Do not carry out additional charging.

When additional charging is carried out if refrigerant leaks, the refrigerant composition changes in the refrigeration cycle, that is characteristics of the air conditioner changes, refrigerant exceeding the specified amount is charged, and working pressure in the refrigeration cycle becomes abnormally high pressure, and may cause a rupture or personal injury.

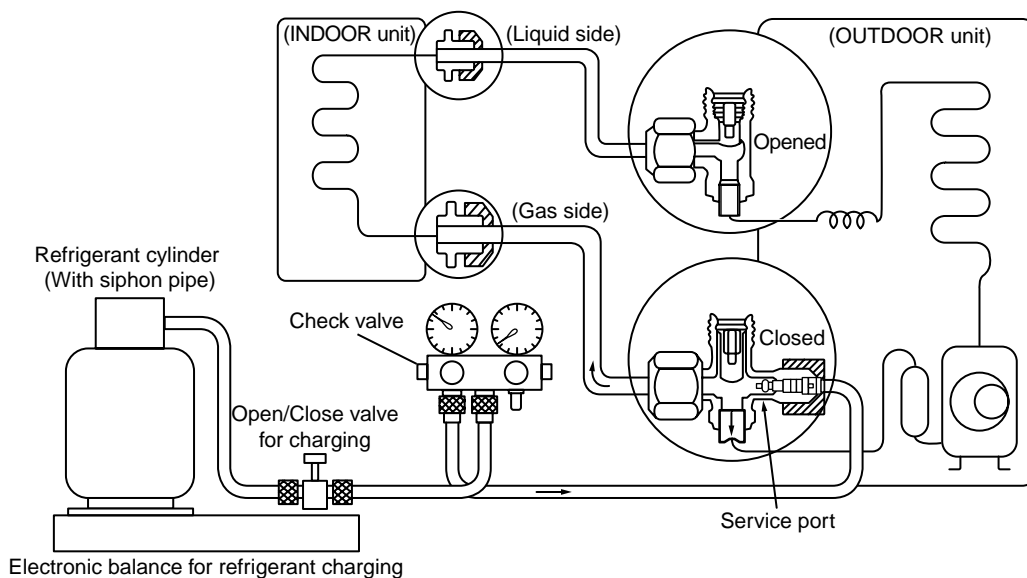
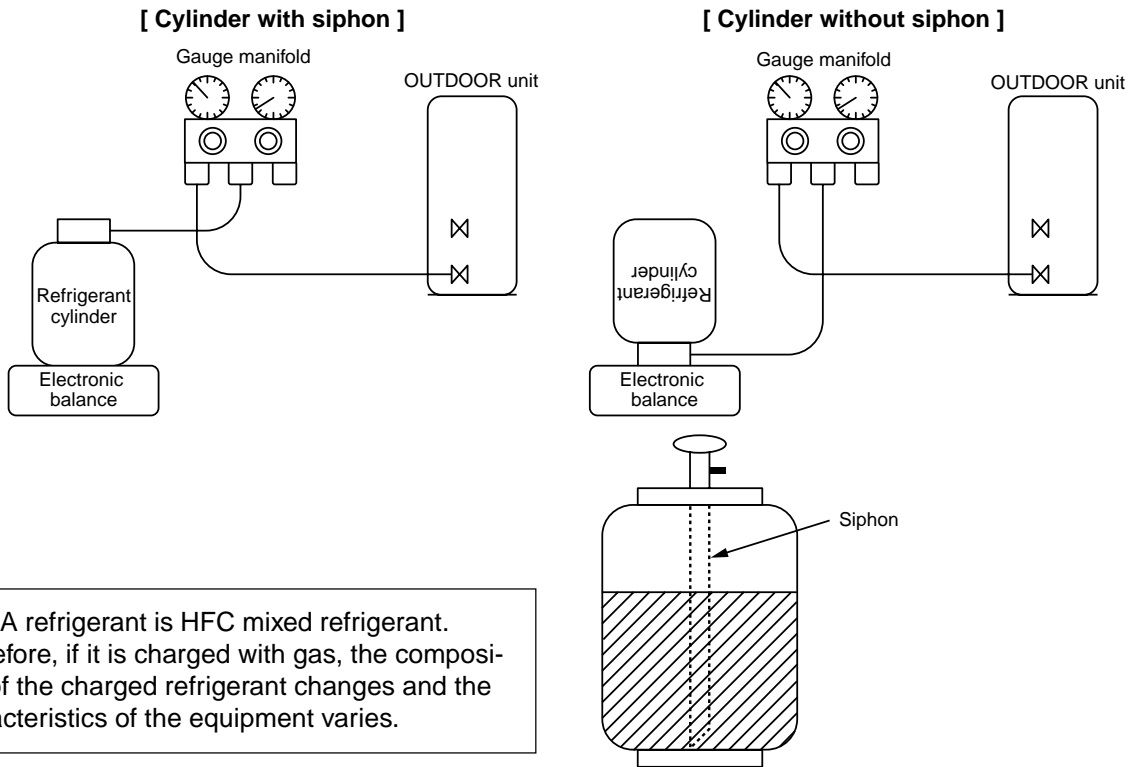

Fig. 7-4-1 Configuration of refrigerant charging

- ① Be sure to make setting so that **liquid** can be charged.
- ② When using a cylinder equipped with a siphon, liquid can be charged without turning it upside down.

It is necessary for charging refrigerant under condition of liquid because R410A is mixed type of refrigerant. Accordingly, when charging refrigerant from the refrigerant cylinder to the equipment, charge it turning the cylinder upside down if cylinder is not equipped with siphon.



R410A refrigerant is HFC mixed refrigerant. Therefore, if it is charged with gas, the composition of the charged refrigerant changes and the characteristics of the equipment varies.

Fig. 7-4-2

7-5. Brazing of Pipes

7-5-1. Materials for Brazing

(1) Silver brazing filler

Silver brazing filler is an alloy mainly composed of silver and copper. It is used to join iron, copper or copper alloy, and is relatively expensive though it excels in solderability.

(2) Phosphor bronze brazing filler

Phosphor bronze brazing filler is generally used to join copper or copper alloy.

(3) Low temperature brazing filler

Low temperature brazing filler is generally called solder, and is an alloy of tin and lead. Since it is weak in adhesive strength, do not use it for refrigerant pipes.

- ① Phosphor bronze brazing filler tends to react with sulfur and produce a fragile compound water solution, which may cause a gas leakage. Therefore, use any other type of brazing filler at a hot spring resort, etc., and coat the surface with a paint.
- ② When performing brazing again at time of servicing, use the same type of brazing filler.

7-5-2. Flux

(1) Reason why flux is necessary

- By removing the oxide film and any foreign matter on the metal surface, it assists the flow of brazing filler.
- In the brazing process, it prevents the metal surface from being oxidized.
- By reducing the brazing filler's surface tension, the brazing filler adheres better to the treated metal.

(2) Characteristics required for flux

- Activated temperature of flux coincides with the brazing temperature.
- Due to a wide effective temperature range, flux is hard to carbonize.
- It is easy to remove slag after brazing.
- The corrosive action to the treated metal and brazing filler is minimum.
- It excels in coating performance and is harmless to the human body.

As the flux works in a complicated manner as described above, it is necessary to select an adequate type of flux according to the type and shape of treated metal, type of brazing filler and brazing method, etc.

(3) Types of flux

• Noncorrosive flux

Generally, it is a compound of borax and boric acid.

It is effective in case where the brazing temperature is higher than 800°C.

• Activated flux

Most of fluxes generally used for silver brazing are this type.

It features an increased oxide film removing capability due to the addition of compounds such as potassium fluoride, potassium chloride and sodium fluoride to the borax-boric acid compound.

(4) Piping materials for brazing and used brazing filler/flux

Piping material	Used brazing filler	Used flux
Copper - Copper	Phosphor copper	Do not use
Copper - Iron	Silver	Paste flux
Iron - Iron	Silver	Vapor flux

- ① Do not enter flux into the refrigeration cycle.
- ② When chlorine contained in the flux remains within the pipe, the lubricating oil deteriorates. Therefore, use a flux which does not contain chlorine.
- ③ When adding water to the flux, use water which does not contain chlorine (e.g. distilled water or ion-exchange water).
- ④ Remove the flux after brazing.

7-5-3. Brazing

As brazing work requires sophisticated techniques, experiences based upon a theoretical knowledge, it must be performed by a person qualified.

In order to prevent the oxide film from occurring in the pipe interior during brazing, it is effective to proceed with brazing while letting dry Nitrogen gas (N₂) flow.

Never use gas other than Nitrogen gas.

(1) Brazing method to prevent oxidation

- ① Attach a reducing valve and a flow-meter to the Nitrogen gas cylinder.
- ② Use a copper pipe to direct the piping material, and attach a flow-meter to the cylinder.
- ③ Apply a seal onto the clearance between the piping material and inserted copper pipe for Nitrogen in order to prevent backflow of the Nitrogen gas.
- ④ When the Nitrogen gas is flowing, be sure to keep the piping end open.
- ⑤ Adjust the flow rate of Nitrogen gas so that it is lower than 0.05 m³/Hr or 0.02 MPa (0.2kgf/cm²) by means of the reducing valve.
- ⑥ After performing the steps above, keep the Nitrogen gas flowing until the pipe cools down to a certain extent (temperature at which pipes are touchable with hands).
- ⑦ Remove the flux completely after brazing.

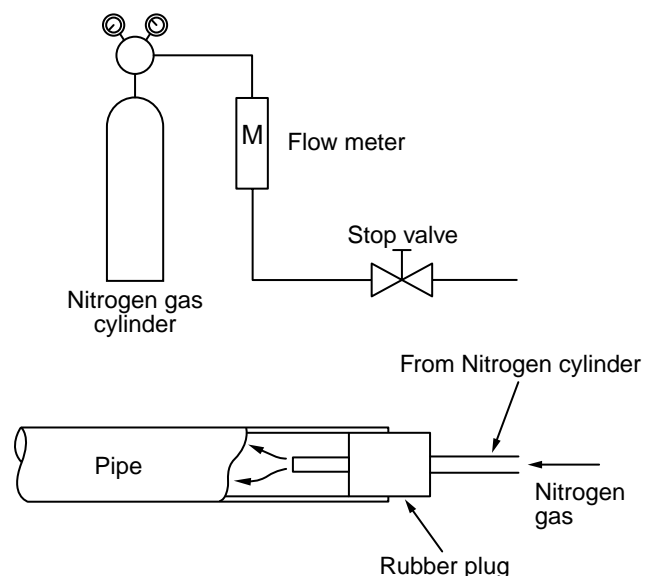
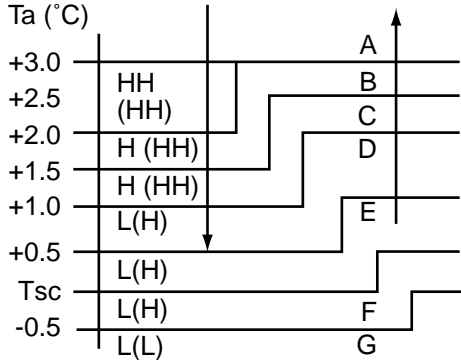
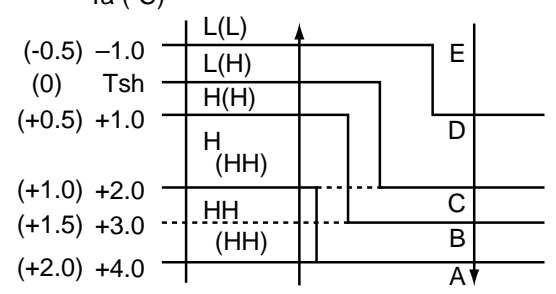
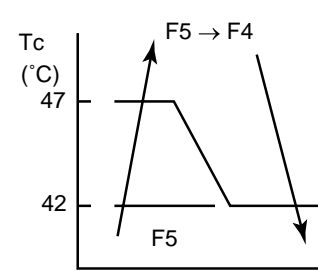

Fig. 7-5-1 Prevention of oxidation during brazing



8-2. Control Specifications

No.	Item	Outline of specifications	Remarks												
1	When power supply is reset	<p>1) Distinction of outdoor units When the power supply is reset, the outdoors are distinguished, and control is exchanged according to the distinguished result.</p> <p>2) Setting of speed of the indoor fan/setting whether to adjust air direction or not. (Only 4-way models) Based on EEPROM data, speed of the indoor fan or setting whether to adjust air direction or not is selected.</p>	Air speed/ Air direction adjustment												
2	Operation mode selection	<p>1) Based on the operation mode selecting command from the remote controller, the operation mode is selected.</p> <table border="1" data-bbox="459 763 1078 1037"> <thead> <tr> <th data-bbox="467 775 699 824">Remote controller command</th> <th data-bbox="703 775 1070 824">Outline of control</th> </tr> </thead> <tbody> <tr> <td data-bbox="467 831 699 869">STOP</td> <td data-bbox="703 831 1070 869">Air conditioner stops.</td> </tr> <tr> <td data-bbox="467 875 699 913">FAN</td> <td data-bbox="703 875 1070 913">Fan operation</td> </tr> <tr> <td data-bbox="467 920 699 958">COOL</td> <td data-bbox="703 920 1070 958">Cooling operation</td> </tr> <tr> <td data-bbox="467 965 699 1003">DRY</td> <td data-bbox="703 965 1070 1003">Dry operation</td> </tr> <tr> <td data-bbox="467 1010 699 1048">HEAT</td> <td data-bbox="703 1010 1070 1048">Heating operation</td> </tr> </tbody> </table> <p data-bbox="544 1043 1070 1126">• COOL/HEAT operation mode is automatically selected by T_a and T_s for operation.</p> <div data-bbox="571 1133 995 1402"> </div> <p data-bbox="467 1424 1070 1480">1) Judge the selection of COOL/HEAT mode as shown in the figure above.</p> <p data-bbox="501 1507 1018 1615">When 10 minutes passed after thermostat had been turned off, the heating operation (Thermo OFF) is exchanged to cooling operation if T_{sh} exceeds +1.5 or more.</p> <p data-bbox="501 1641 1058 1697">(COOL OFF) and (COOL ON) in the figure indicate an example.</p> <p data-bbox="501 1724 1018 1832">When 10 minutes passed after thermostat had been turned off, the cooling operation (Thermo OFF) is exchanged to heating operation if T_{sc} exceeds -1.5 or less.</p> <p data-bbox="467 1859 1070 1915">2) For the automatic capacity control after judgment of COOL/HEAT, refer to item 4.</p> <p data-bbox="467 1917 1070 1973">3) For the temperature correction of room temperature control in automatic heating operation, refer to item 3.</p>	Remote controller command	Outline of control	STOP	Air conditioner stops.	FAN	Fan operation	COOL	Cooling operation	DRY	Dry operation	HEAT	Heating operation	<p>T_a : Room temperature T_s : Setup temperature T_{sc} : Setup temperature in cooling operation T_{sh} : Setup temperature + Room temperature control temperature compensation</p>
Remote controller command	Outline of control														
STOP	Air conditioner stops.														
FAN	Fan operation														
COOL	Cooling operation														
DRY	Dry operation														
HEAT	Heating operation														

No.	Item	Outline of specifications	Remarks																								
3	Room temperature control	<p>1) Adjustment range Remote controller setup temperature (°C)</p> <table border="1" data-bbox="475 293 1082 443"> <thead> <tr> <th></th> <th>COOL/ DRY</th> <th>Heating operation</th> <th>Auto operation</th> </tr> </thead> <tbody> <tr> <td>Wired type</td> <td>18 to 29</td> <td>18 to 29</td> <td>18 to 29</td> </tr> <tr> <td>Wireless type*</td> <td>18 to 30</td> <td>16 to 30</td> <td>17 to 27</td> </tr> </tbody> </table> <p>* : Only for 4-way air discharge cassette type</p> <p>2) Using the item code 06, the setup temperature in heating operation can be compensated.</p> <table border="1" data-bbox="475 577 1082 689"> <tbody> <tr> <td>Setup data</td> <td>0</td> <td>2</td> <td>4</td> <td>6</td> </tr> <tr> <td>Setup temp. compensation</td> <td>+0°C</td> <td>+2°C</td> <td>+4°C</td> <td>+6°C</td> </tr> </tbody> </table> <p>Setting at shipment</p> <table border="1" data-bbox="475 745 762 790"> <tbody> <tr> <td>Setup data</td> <td>2</td> </tr> </tbody> </table>		COOL/ DRY	Heating operation	Auto operation	Wired type	18 to 29	18 to 29	18 to 29	Wireless type*	18 to 30	16 to 30	17 to 27	Setup data	0	2	4	6	Setup temp. compensation	+0°C	+2°C	+4°C	+6°C	Setup data	2	Shift of suction temperature in heating operation
	COOL/ DRY	Heating operation	Auto operation																								
Wired type	18 to 29	18 to 29	18 to 29																								
Wireless type*	18 to 30	16 to 30	17 to 27																								
Setup data	0	2	4	6																							
Setup temp. compensation	+0°C	+2°C	+4°C	+6°C																							
Setup data	2																										
4	Automatic capacity control (GA control)	1) Based on the difference between Ta and Ts, the operation frequency is instructed to the outdoor unit.																									
5	Air speed selection	<p>1) Operation with (HH), (H), (L), or [AUTO] mode is performed by the command from the remote controller.</p> <p>2) When the air speed mode [AUTO] is selected, the air speed varies by the difference between Ta and Ts.</p> <p><COOL></p>  <ul style="list-style-type: none"> Controlling operation in case when thermo of remote controller works is same as a case when thermo of the body works. If the air speed has been changed once, it is not changed for 3 minutes. However when the air volume is exchanged, the air speed changes. When cooling operation has started, the air speed selects a downward slope, that is, the high position. If the temperature is just on the difference boundary, the air speed does not change. Mode in the parentheses indicates one in automatic cooling operation. 	HH > H > L > LL																								

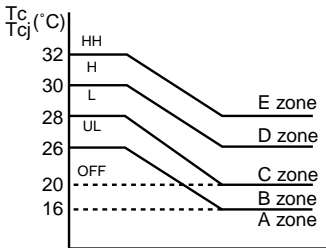
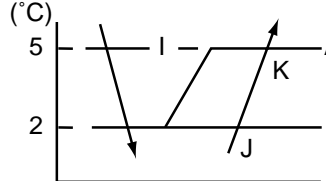
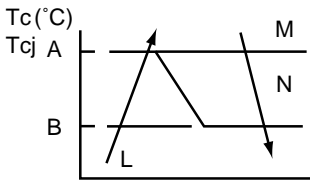
No.	Item	Outline of specifications	Remarks																																																																																																								
5	Air speed selection (Continued)	<p><HEAT></p> <p>Ta (°C)</p>  <p>Value in the parentheses indicates one when thermostat of the remote controller works. Value without parentheses indicates one when thermostat of the body works.</p> <ul style="list-style-type: none"> • If the air speed has been changed once, it is not changed for 1 minute. However when the air speed is exchanged, the air speed changes. • When heating operation has started, the air speed selects a upward slope, that is, the high position. • If the temperature is just on the difference boundary, the air speed does not change. • Mode in the parentheses indicates one in automatic heating operation. • In $T_c \geq 60^\circ\text{C}$, the air speed increases by 1 step. <p><Operation of duct only></p> <table border="1" data-bbox="430 1097 1077 1668"> <thead> <tr> <th colspan="2">Standard</th> <th colspan="2">High ceiling</th> <th rowspan="2">Tap</th> <th>SM560</th> <th>SM800</th> </tr> <tr> <th>COOL</th> <th>HEAT</th> <th>COOL</th> <th>HEAT</th> <th colspan="2">Revolutions per minute (rpm)</th> </tr> </thead> <tbody> <tr> <td>UL</td> <td>UL</td> <td></td> <td></td> <td>FD</td> <td>320</td> <td>320</td> </tr> <tr> <td>L</td> <td></td> <td></td> <td></td> <td>FD</td> <td>320</td> <td>330</td> </tr> <tr> <td>L+</td> <td>L</td> <td></td> <td></td> <td>FB</td> <td>330</td> <td>340</td> </tr> <tr> <td></td> <td>L+</td> <td></td> <td></td> <td>FA</td> <td>350</td> <td>360</td> </tr> <tr> <td>M</td> <td></td> <td></td> <td></td> <td>F9</td> <td>360</td> <td>370</td> </tr> <tr> <td></td> <td>M</td> <td>UL</td> <td>UL</td> <td>F8</td> <td>370</td> <td>380</td> </tr> <tr> <td>M+</td> <td>M+</td> <td>L</td> <td>L</td> <td>F7</td> <td>400</td> <td>410</td> </tr> <tr> <td>H</td> <td></td> <td>L+</td> <td>L+</td> <td>F6</td> <td>410</td> <td>440</td> </tr> <tr> <td></td> <td>H</td> <td></td> <td></td> <td>F5</td> <td>420</td> <td>450</td> </tr> <tr> <td></td> <td></td> <td></td> <td></td> <td>F4</td> <td>440</td> <td>480</td> </tr> <tr> <td></td> <td></td> <td>M+,M</td> <td>M+,M</td> <td>F3</td> <td>480</td> <td>500</td> </tr> <tr> <td></td> <td></td> <td></td> <td></td> <td>F2</td> <td>530</td> <td>540</td> </tr> <tr> <td></td> <td></td> <td>H</td> <td>H</td> <td>F1</td> <td>580</td> <td>580</td> </tr> </tbody> </table> <p>3) In heating operation, the mode changes to [UL] if thermostat is turned off.</p> <p>4) If $T_a \geq 25^\circ\text{C}$ when heating operation has started and when defrost operation has been cleared, it operates with HIGH (H) mode or (HH) for 1 minute from when T_c has entered in E zone of cool air discharge preventive control (Item 6).</p> <p>5) In automatic cooling/heating operation, the revolution frequency of [HH] is set larger than that in the standard cooling/heating operation. However the revolution frequency is restricted in the automatic heating operation as shown in the following figure.</p> 	Standard		High ceiling		Tap	SM560	SM800	COOL	HEAT	COOL	HEAT	Revolutions per minute (rpm)		UL	UL			FD	320	320	L				FD	320	330	L+	L			FB	330	340		L+			FA	350	360	M				F9	360	370		M	UL	UL	F8	370	380	M+	M+	L	L	F7	400	410	H		L+	L+	F6	410	440		H			F5	420	450					F4	440	480			M+,M	M+,M	F3	480	500					F2	530	540			H	H	F1	580	580	<p>Tc: Indoor heat exchanger sensor temperature</p> <p>[PRE-HEAT] display</p>
Standard		High ceiling		Tap	SM560	SM800																																																																																																					
COOL	HEAT	COOL	HEAT		Revolutions per minute (rpm)																																																																																																						
UL	UL			FD	320	320																																																																																																					
L				FD	320	330																																																																																																					
L+	L			FB	330	340																																																																																																					
	L+			FA	350	360																																																																																																					
M				F9	360	370																																																																																																					
	M	UL	UL	F8	370	380																																																																																																					
M+	M+	L	L	F7	400	410																																																																																																					
H		L+	L+	F6	410	440																																																																																																					
	H			F5	420	450																																																																																																					
				F4	440	480																																																																																																					
		M+,M	M+,M	F3	480	500																																																																																																					
				F2	530	540																																																																																																					
		H	H	F1	580	580																																																																																																					

No.	Item	Outline of specifications	Remarks						
6	Cool air discharge preventive control	<p>1) In heating operation, the indoor fan is controlled based on the detected temperature of Tc sensor or Tcj sensor. As shown below, the upper limit of the revolution frequency is determined.</p> 	<p>In D or E zone, the priority is given to setup of air volume exchange. In A and B zones, [PRE-HEAT] is displayed.</p>						
7	Freeze preventive control (Low temperature release)	<p>1) The cooling operation (including Dry operation) is performed as follows based on the detected temperature of Tc sensor or Tcj sensor.</p> <p>When [J] zone is detected for 6 minutes (Following figure), the commanded frequency is decreased from the real operation frequency. After then the commanded frequency changes every 30 seconds while operation is performed in [J] zone.</p> <p>In [K] zone, time counting is interrupted and the operation is held.</p> <p>When [I] zone is detected, the timer is cleared and the operation returns to the normal operation.</p> <p>If the commanded frequency becomes S0 because the operation continues in [J] zone, the return temperature A is raised from 5°C to 12°C until [I] zone is detected and the indoor fan operates with [M] mode.</p>  <p>In heating operation, the freeze-preventive control works if 4-way valve is not exchanged and the condition is satisfied. (However the temperature for J zone dashing control is changed from 2°C to -5°C.)</p>	Tcj : Indoor heat exchanger sensor temperature						
8	High-temp release control	<p>1) The heating operation is performed as follows based on the detected temperature of Tc sensor or Tcj sensor.</p> <ul style="list-style-type: none"> When [M] zone is detected, the commanded frequency is decreased from the real operation frequency. After then the commanded frequency changes every 30 seconds while operation is performed in [M] zone. In [N] zone, the commanded frequency is held. When [L] zone is detected, the commanded frequency is returned to the original value by approx. 6Hz every 60 seconds. <p>Setup at shipment</p> <table border="1" data-bbox="534 1780 758 1915"> <thead> <tr> <th colspan="2">Control temp (°C)</th> </tr> </thead> <tbody> <tr> <td>A</td> <td>B</td> </tr> <tr> <td>56 (54)</td> <td>52 (52)</td> </tr> </tbody> </table>  <p>NOTE : When the operation has started or when Tc or Tcj became lower than 30°C after start of the operation, temperature is controlled between values in parentheses of A and B.</p>	Control temp (°C)		A	B	56 (54)	52 (52)	Same when thermostat is turned off.
Control temp (°C)									
A	B								
56 (54)	52 (52)								

No.	Item	Outline of specifications	Remarks
9	Drain pump control (For the duct, when the drain-up kit (sold separately) is mounted)	1) In cooling operation (including Dry operation), the drain pump is usually operated. 2) If the float switch operates while drain pump operates, the compressor stops, the drain pump continues the operation, and a check code is output. 3) If the float switch operates while drain pump stops, the compressor stops and the drain pump operates. If the float switch keeps operating for approx. 4 minutes, a check code is output.	Check code [P10]
10	After-heat elimination	When heating operation stops, the indoor fan operates with LOW mode for approx. 30 seconds.	
11	Flap control (For 4-way air discharge cassette type only)	1) Flap position setup <ul style="list-style-type: none"> • When the flap position is changed, the position moves necessarily to downward discharge position once to return to the set position. • The flap position can be set up in the following operation range. <p style="text-align: center;">In cooling/dry operation In heating/fan operation</p> <div style="display: flex; justify-content: space-around; align-items: center;">   </div> <ul style="list-style-type: none"> • In group twin/triple operation, the flap positions can be set up collectively or individually. 2) Swing setup <ul style="list-style-type: none"> • The swinging position can be moved in the following operation range. <p style="text-align: center;">All modes</p> <div style="text-align: center;">  </div> <ul style="list-style-type: none"> • In group twin/triple operation, the swinging positions can be set up collectively or individually. 3) When the unit stops or when a warning is output, the flap automatically moves downward. 4) While the heating operation is ready, the flap automatically moves upward.	<p>Warning : A check code is displayed on the remote controller, and the indoor unit stops. (Excluding [F08] and [L31])</p>

No.	Item	Outline of specifications	Remarks
12	Frequency fixed operation (Test run)	<p><In case of wired remote controller></p> <ol style="list-style-type: none"> 1. When pushing [CHECK] button for 4 seconds or more, [TEST] is displayed on the display screen and the mode enters in Test run mode. 2. Push [ON/OFF] button. 3. Using [MODE] button, change the mode from [COOL] to [HEAT]. <ul style="list-style-type: none"> • Do not use other mode than [COOL]/[HEAT] mode. • During test run operation, the temperature cannot be adjusted. • An error is detected as usual. • A frequency fixed operation is performed. 4. After the test run, push [ON/OFF] button to stop the operation. (Display in the display part is same as the procedure in item 1).) 5. Push [CHECK] button to clear the test run mode. ([TEST] display in the display part disappears and the status returns to the normal stop status.) <p><In case of wireless remote controller> (Option for 4-way air discharge cassette type only)</p> <ol style="list-style-type: none"> 1. Turn off the power of the set. Remove the adjuster with sensors from the ceiling panel. 2. Turn Bit [1: TEST] of sensor P.C. board switch [S003] from OFF to ON. Attach the sensor P.C. board cover and mount the adjuster with sensors to the ceiling panel. Turn on the power of the set. 3. Push [ON/OFF] button of the wireless remote controller and set the operation mode to [COOL] or [HEAT] using [MODE] button. (During test run operation, all the display lamps of wireless remote controller sensors flash.) <ul style="list-style-type: none"> • Do not use other mode than [COOL]/[HEAT] mode. • An error is detected as usual. • A frequency fixed operation is performed. 4. After the test run, push [ON/OFF] button to stop the operation. 5. Turn off the power of the set. Turn Bit [1: TEST] of sensor P.C. board switch [S003] from ON to OFF. Mount the adjuster with sensors to the ceiling panel. 	
13	Filter sign display (Except wireless type)	<ol style="list-style-type: none"> 1) The operation time of the indoor fan is calculated, the filter reset signal is sent to the remote controller when the specified time (2500H) has passed, and it is displayed on LCD. 2) When the filter reset signal has been received from the remote controller, time of the calculation timer is cleared. In this case, the measurement time is reset if the specified time has passed, and display on LCD disappears. 	[FILTER] goes on.

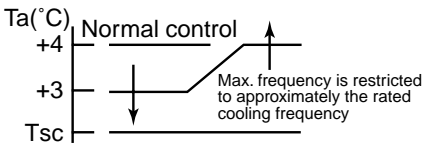
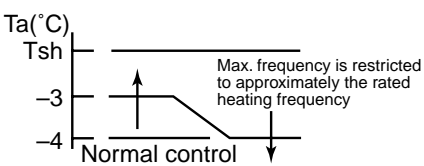
No.	Item	Outline of specifications	Remarks
14	Central control mode selection	1) Setting at the central controller side enables to select the contents which can be operated on the remote controller at indoor unit side. 2) RBC-AMT21 [Last push priority] : The operation contents can be selected from both remote controller and central controller of the indoor unit side, and the operation is performed with the contents selected at the last. [Center] : Start/Stop operation only can be handled on the remote controller at indoor unit side. [Operation Prohibited] : It cannot be operated on the remote controller at indoor unit side. (Stop status is held.)	(No display) [CENTER] goes on. [CENTER] goes on. In a case of wireless type, the display lamp does not change. However, contents which can be operated are same. The status set in [CENTER]/ [Operation Prohibited] mode is notified with the receiving sound "Pi, Pi, Pi, Pi, Pi" (5 times).
15	Energy-save control (By connected outdoor unit)	1) Selecting [AUTO] mode enables an energy-saving to be operated. 2) The setup temperature is shifted (corrected) in the range not to lose the comfort ability according to input values of various sensors. 3) Data (Input value room temp. Ta, Outside temp. To, Air volume, Indoor heat exchanger sensor temp. Tc) for 20 minutes are taken the average to calculate correction value of the setup temperature. 4) The setup temperature is shifted every 20 minutes, and the shifted range is as follows. In cooling time : +1.5 to -1.0K In heating time : -1.5 to +1.0K	
16	Max. frequency cut control	1) This control is operated by selecting [AUTO] operation mode. 2) COOL operation mode: the frequency is controlled according to the following figure if To < 28°C.  3) HEAT operation mode: the frequency is controlled according to the right figure if To > 15°C. 	
17	DC motor (For 4-way air discharge cassette type only)	1) When the fan operation has started, positioning of the stator and the rotor are performed. (Moves slightly with tap sound) 2) The motor operates according to the command from the indoor controller. NOTES : <ul style="list-style-type: none"> • When the fan rotates while the air conditioner stops due to entering of outside air, etc, the air conditioner may operated while the fan motor stops. • When a fan locking is found, the air conditioner stops, and an error is displayed. 	Check code [P12]

8-3. Indoor Print Circuit Board

4-Way Air Discharge Cassette Type
RAV-SM560UT-E/RAV-SM800UT-E

<MCC-1402>

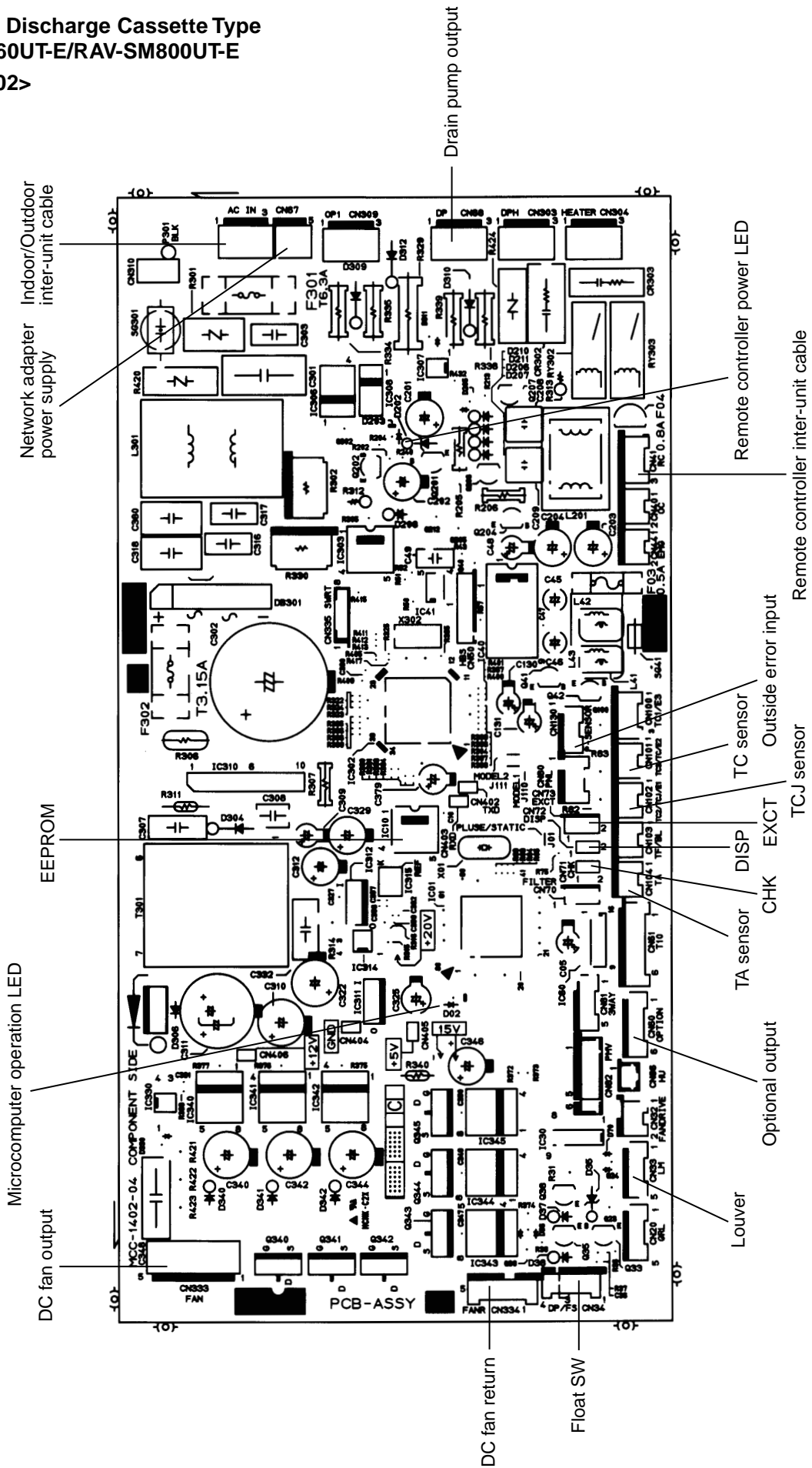

Concealed Duct Type
RAV-SM560BT-E/RAV-SM800BT-E
 <MCC-1403>

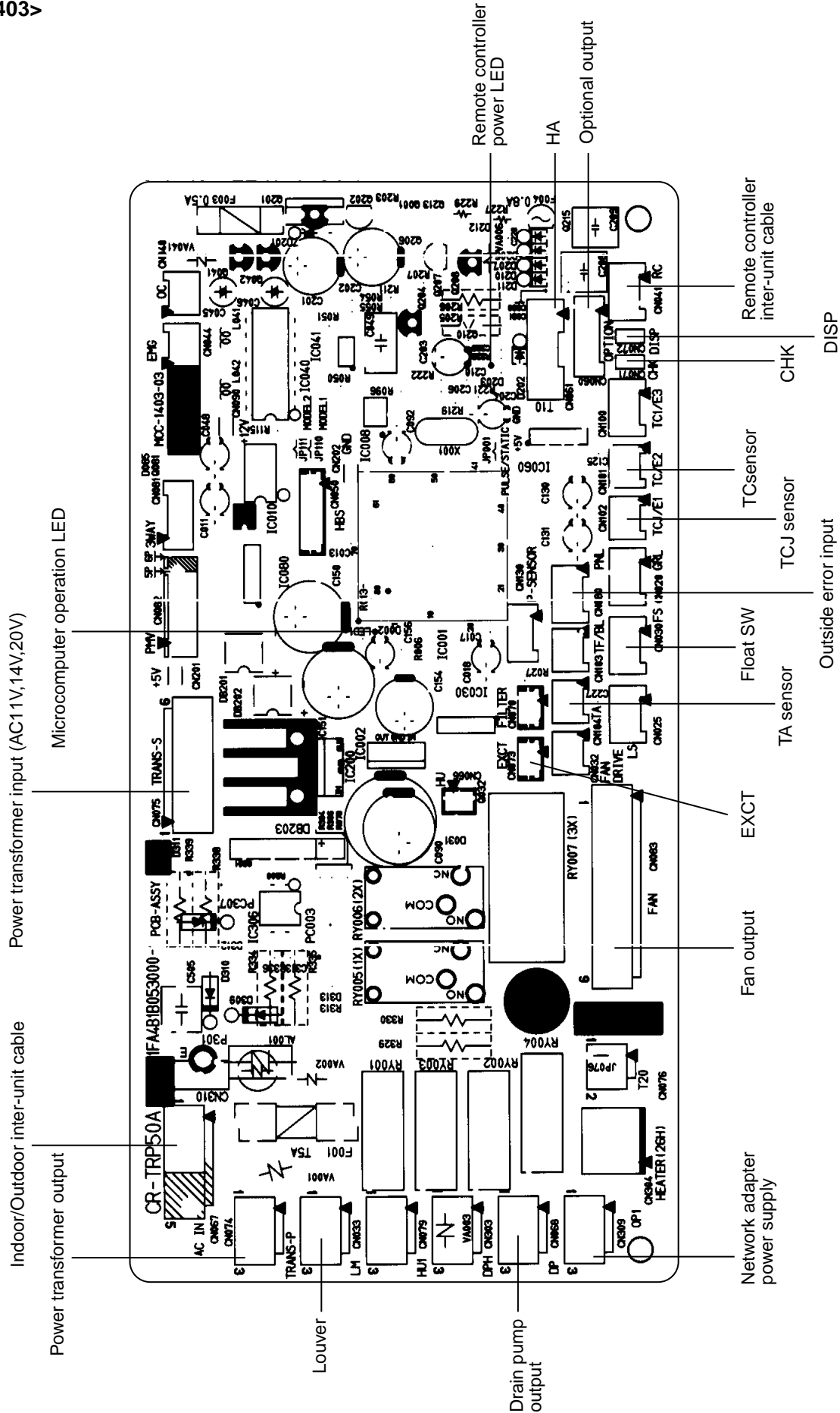

9. CIRCUIT CONFIGURATION AND CONTROL SPECIFICATIONS

9-1. Microcomputer System Block Diagram

9-1-1. Connection of Main Remote Controller

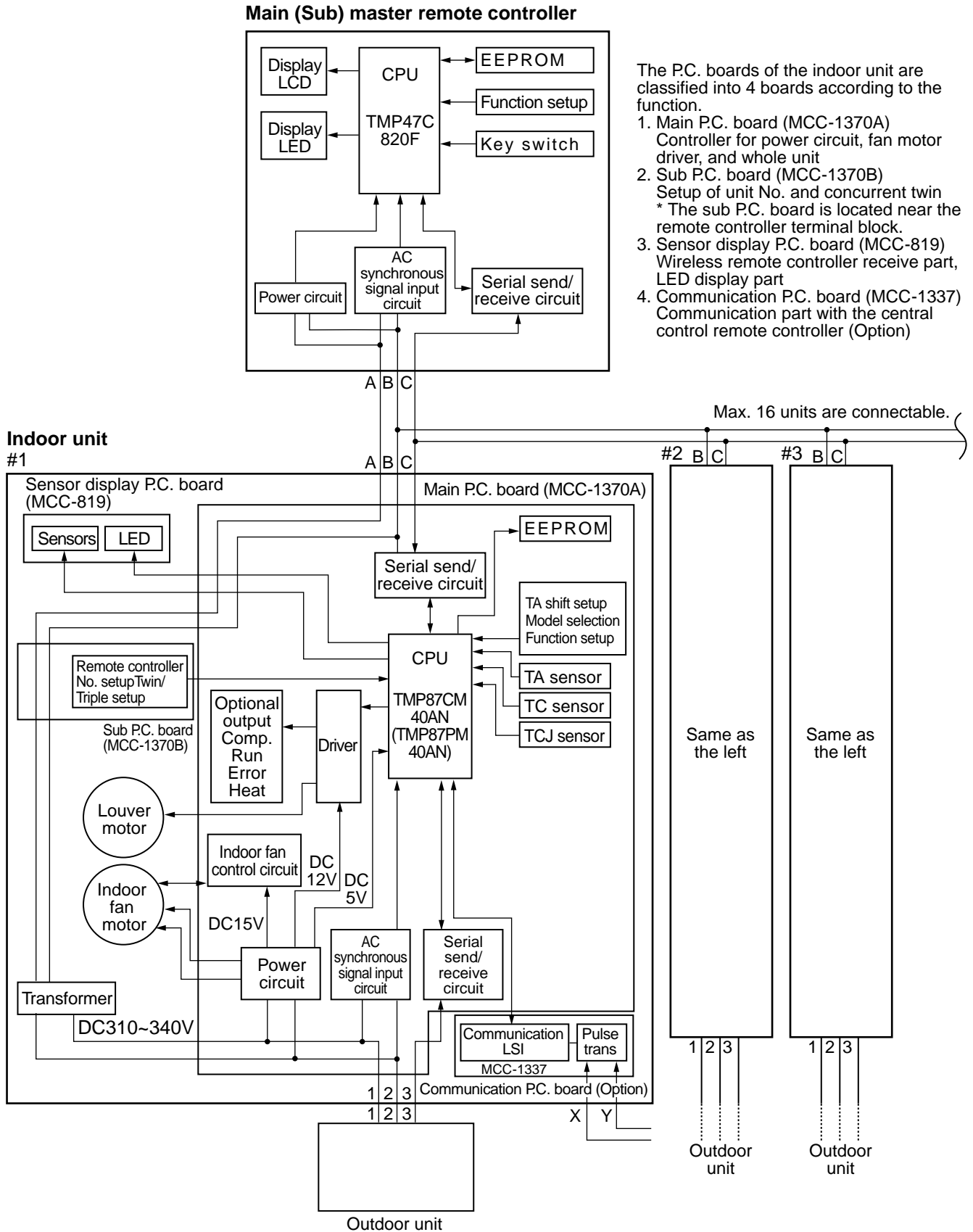

9-1-2. Connection of Wireless Remote Controller

Indoor unit

#1

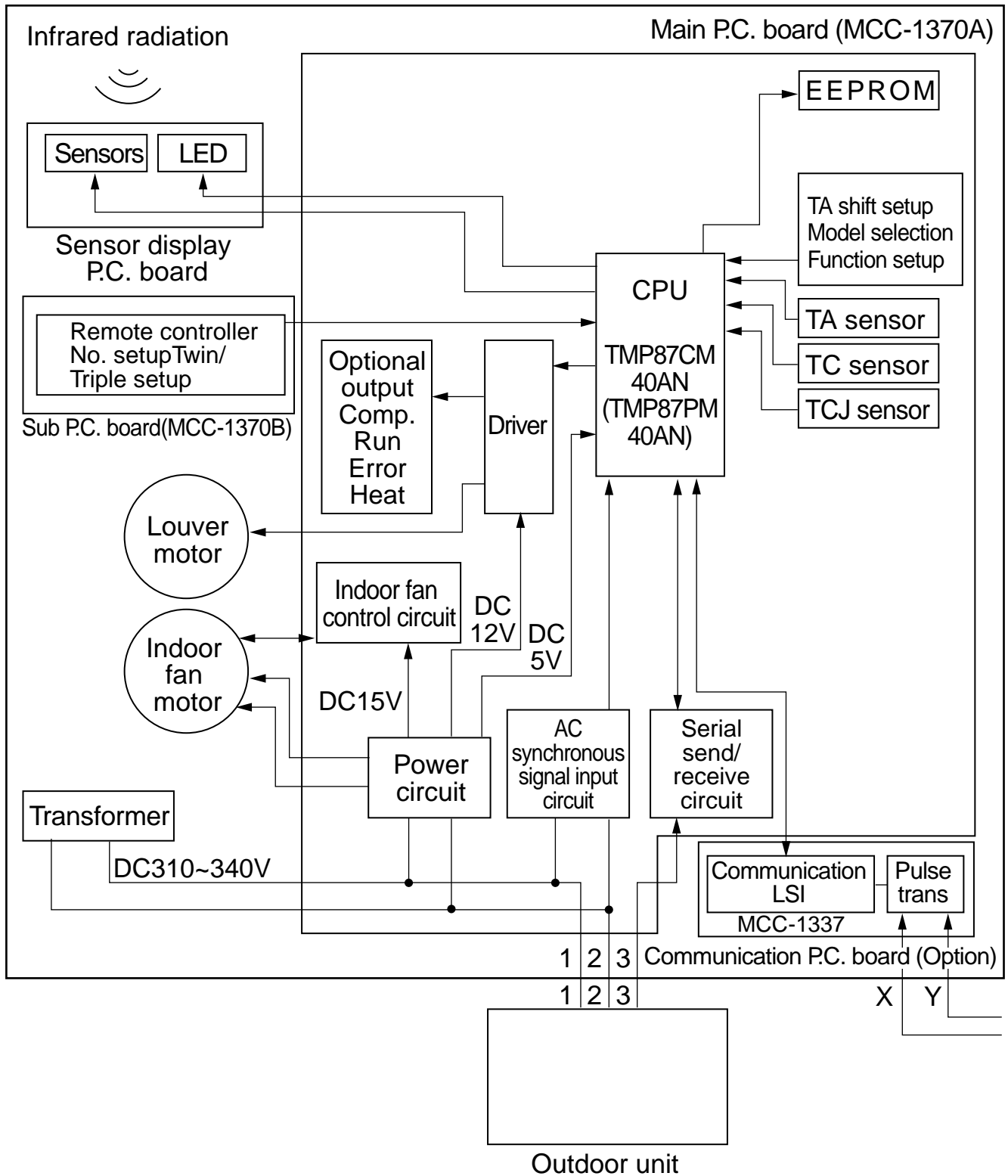





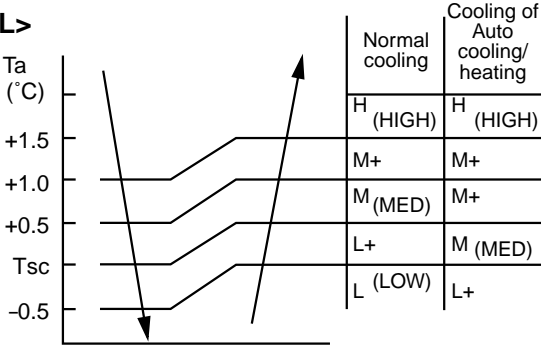
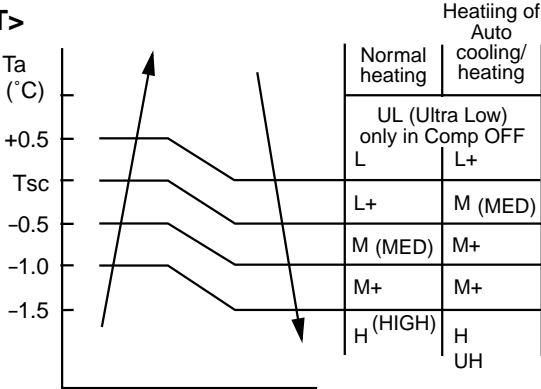

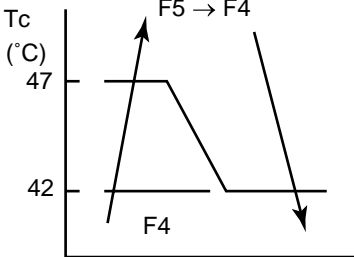
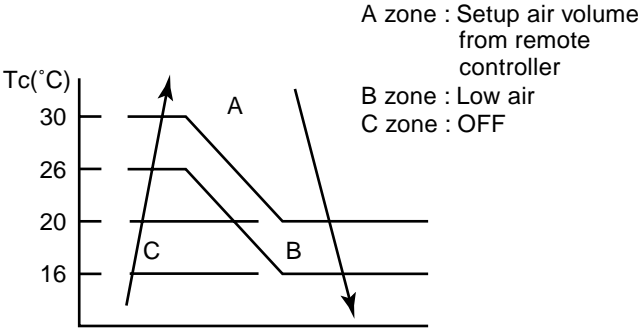
9-1-3. Control Specifications

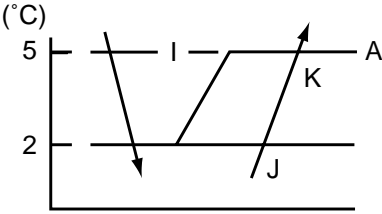
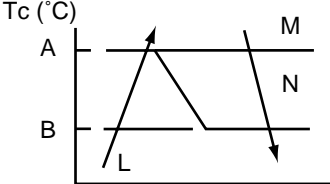
No.	Item	Outline of specifications	Remarks																																																											
1	When power supply is reset	1) Distinction of outdoor units When the power supply is reset, the outdoors are distinguished, and control is exchanged according to the distinguished result. 2) Setting of the indoor fan speed Based on EEPROM data, rspeed of the indoor fan is selected.	Air speed																																																											
2	Operation mode selection	1) Based on the operation mode selecting command from the remote controller, the operation mode is selected. <table border="1" style="margin: 10px 0;"> <thead> <tr> <th>Remote controller command</th> <th>Outline of control</th> </tr> </thead> <tbody> <tr> <td>STOP</td> <td>Air conditioner stops.</td> </tr> <tr> <td>FAN</td> <td>Fan operation</td> </tr> <tr> <td>COOL</td> <td>Cooling operation</td> </tr> <tr> <td>DRY</td> <td>Dry operation</td> </tr> <tr> <td>HEAT</td> <td>Heating operation</td> </tr> <tr> <td>AUTO</td> <td> </td> </tr> </tbody> </table> 1) Judge the selection of COOL/HEAT mode as shown in the figure below. When the heating operation (Thermo OFF) is exchanged to cooling operation if Tsh exceeds +3 or more. (COOL OFF) and (COOL ON) in the figure indicate an example. When the cooling operation (Thermo OFF) is exchanged to heating operation if Tsc exceeds -3 or less. 2) For the automatic capacity control after judgment of COOL/HEAT, refer to item 4. 3) For the temperature correction of room temperature control in automatic heating operation, refer to item 3.	Remote controller command	Outline of control	STOP	Air conditioner stops.	FAN	Fan operation	COOL	Cooling operation	DRY	Dry operation	HEAT	Heating operation	AUTO		Ta : Room temperature Ts : Setup temperature Tsc : Setup temperature in cooling operation Tsh : Setup temperature in heating operation																																													
Remote controller command	Outline of control																																																													
STOP	Air conditioner stops.																																																													
FAN	Fan operation																																																													
COOL	Cooling operation																																																													
DRY	Dry operation																																																													
HEAT	Heating operation																																																													
AUTO																																																														
3	Room temperature control	1) Adjustment range Remote controller setup temperature (°C) <table border="1" style="margin: 10px 0;"> <thead> <tr> <th></th> <th>COOL/ DRY</th> <th>Heating operation</th> <th>Auto operation</th> </tr> </thead> <tbody> <tr> <td>Standard type</td> <td>18 to 29</td> <td>18 to 29</td> <td>18 to 29</td> </tr> <tr> <td>Wireless type</td> <td>17 to 30</td> <td>17 to 30</td> <td>19 to 29</td> </tr> </tbody> </table> <table border="1" style="margin: 10px 0;"> <tr> <td>Remote controller setup temp</td> <td>5</td> <td>4</td> <td>3</td> <td>2</td> <td>1</td> <td>Standard</td> <td>1</td> <td>2</td> <td>3</td> <td>4</td> <td>5</td> </tr> <tr> <td>Setup temp (°C)</td> <td>19</td> <td>20</td> <td>21</td> <td>22</td> <td>23</td> <td>24</td> <td>25</td> <td>26</td> <td>27</td> <td>28</td> <td>29</td> </tr> </table> 2) Differential 1K (=deg) 3) In heating operation, the setup temperature can be corrected by using Dip switch (SW03) on the indoor P.C. board. <table border="1" style="margin: 10px 0;"> <thead> <tr> <th rowspan="2">SW03</th> <th>1</th> <th>ON</th> <th>ON</th> <th>OFF</th> <th>OFF</th> </tr> <tr> <th>2</th> <th>ON</th> <th>OFF</th> <th>ON</th> <th>OFF</th> </tr> </thead> <tbody> <tr> <td>Setup temp correction</td> <td></td> <td>+0°C</td> <td>+2°C</td> <td>+4°C</td> <td>+6°C</td> </tr> </tbody> </table> <table border="1" style="margin: 10px 0;"> <thead> <tr> <th colspan="2">SW03</th> </tr> </thead> <tbody> <tr> <td>1</td> <td>2</td> </tr> <tr> <td>ON</td> <td>OFF</td> </tr> </tbody> </table>		COOL/ DRY	Heating operation	Auto operation	Standard type	18 to 29	18 to 29	18 to 29	Wireless type	17 to 30	17 to 30	19 to 29	Remote controller setup temp	5	4	3	2	1	Standard	1	2	3	4	5	Setup temp (°C)	19	20	21	22	23	24	25	26	27	28	29	SW03	1	ON	ON	OFF	OFF	2	ON	OFF	ON	OFF	Setup temp correction		+0°C	+2°C	+4°C	+6°C	SW03		1	2	ON	OFF	Max. setup temperature Ts (Max) = 35°C Setup at shipment
	COOL/ DRY	Heating operation	Auto operation																																																											
Standard type	18 to 29	18 to 29	18 to 29																																																											
Wireless type	17 to 30	17 to 30	19 to 29																																																											
Remote controller setup temp	5	4	3	2	1	Standard	1	2	3	4	5																																																			
Setup temp (°C)	19	20	21	22	23	24	25	26	27	28	29																																																			
SW03	1	ON	ON	OFF	OFF																																																									
	2	ON	OFF	ON	OFF																																																									
Setup temp correction		+0°C	+2°C	+4°C	+6°C																																																									
SW03																																																														
1	2																																																													
ON	OFF																																																													

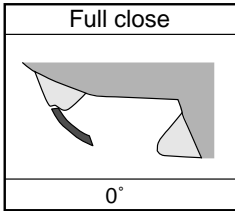
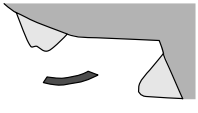
No.	Item	Outline of specifications	Remarks																																				
4	Automatic capacity control (GA control)	<p>1) Based on the difference between T_a and T_s, the operation frequency is instructed to the outdoor unit.</p> <p>NOTE : In cooling operation : When calculating the following conditions for 29 minutes, the commanded frequency is assumed as the rated cooling frequency.</p> <table border="1" data-bbox="443 470 1078 640"> <tr><td>1</td><td>$T_a < 28^\circ\text{C}$</td></tr> <tr><td>2</td><td>Indoor fan [High]</td></tr> <tr><td>3</td><td>$32^\circ\text{C} < T_o \leq 38^\circ\text{C}$ or no T_o</td></tr> <tr><td>4</td><td>Operation exceeding the rated cooling frequency</td></tr> </table> <p>In heating operation: When calculating the following conditions for 29 minutes, the commanded frequency is assumed as the rated heating frequency.</p> <table border="1" data-bbox="443 754 1078 965"> <tr><td>1</td><td>$T_a \geq 19^\circ\text{C}$</td></tr> <tr><td>2</td><td>Indoor fan [High]</td></tr> <tr><td>3</td><td>$5^\circ\text{C} < T_o \leq 10^\circ\text{C}$ or no T_o</td></tr> <tr><td>4</td><td>Operation exceeding the rated heating frequency</td></tr> <tr><td>5</td><td>$T_c \geq 38^\circ\text{C}$</td></tr> </table> <p>NOTE : When air volume is set to [L], the maximum frequency is restricted.</p>	1	$T_a < 28^\circ\text{C}$	2	Indoor fan [High]	3	$32^\circ\text{C} < T_o \leq 38^\circ\text{C}$ or no T_o	4	Operation exceeding the rated cooling frequency	1	$T_a \geq 19^\circ\text{C}$	2	Indoor fan [High]	3	$5^\circ\text{C} < T_o \leq 10^\circ\text{C}$ or no T_o	4	Operation exceeding the rated heating frequency	5	$T_c \geq 38^\circ\text{C}$	<p>T_c : Temperature of indoor heat exchanger sensor</p>																		
1	$T_a < 28^\circ\text{C}$																																						
2	Indoor fan [High]																																						
3	$32^\circ\text{C} < T_o \leq 38^\circ\text{C}$ or no T_o																																						
4	Operation exceeding the rated cooling frequency																																						
1	$T_a \geq 19^\circ\text{C}$																																						
2	Indoor fan [High]																																						
3	$5^\circ\text{C} < T_o \leq 10^\circ\text{C}$ or no T_o																																						
4	Operation exceeding the rated heating frequency																																						
5	$T_c \geq 38^\circ\text{C}$																																						
5	Air volume control	<p>1) Operation with [HIGH (H)], [MED (M)], [LOW (L)], or [AUTO] mode is performed by the command from the remote controller.</p> <p>2) When the air volume mode [AUTO] is selected, the air volume varies by the difference between T_a and T_s.</p> <p><COOL></p>  <table border="1" data-bbox="882 1305 1082 1603"> <thead> <tr> <th></th> <th>Normal cooling</th> <th>Cooling of Auto cooling/heating</th> </tr> </thead> <tbody> <tr><td>H (HIGH)</td><td>H (HIGH)</td><td>H (HIGH)</td></tr> <tr><td>M+</td><td>M+</td><td>M+</td></tr> <tr><td>M (MED)</td><td>M (MED)</td><td>M+</td></tr> <tr><td>L+</td><td>L+</td><td>M (MED)</td></tr> <tr><td>L (LOW)</td><td>L (LOW)</td><td>L+</td></tr> </tbody> </table> <p><HEAT></p>  <table border="1" data-bbox="882 1664 1082 2051"> <thead> <tr> <th></th> <th>Normal heating</th> <th>Heating of Auto cooling/heating</th> </tr> </thead> <tbody> <tr><td>L</td><td>UL (Ultra Low) only in Comp OFF</td><td>L+</td></tr> <tr><td>L+</td><td>L+</td><td>M (MED)</td></tr> <tr><td>M (MED)</td><td>M (MED)</td><td>M+</td></tr> <tr><td>M+</td><td>M+</td><td>M+</td></tr> <tr><td>H (HIGH)</td><td>H (HIGH)</td><td>H UH</td></tr> </tbody> </table>		Normal cooling	Cooling of Auto cooling/heating	H (HIGH)	H (HIGH)	H (HIGH)	M+	M+	M+	M (MED)	M (MED)	M+	L+	L+	M (MED)	L (LOW)	L (LOW)	L+		Normal heating	Heating of Auto cooling/heating	L	UL (Ultra Low) only in Comp OFF	L+	L+	L+	M (MED)	M (MED)	M (MED)	M+	M+	M+	M+	H (HIGH)	H (HIGH)	H UH	<p>$UH > H > M+ > M > L+ > L > UL$</p>
	Normal cooling	Cooling of Auto cooling/heating																																					
H (HIGH)	H (HIGH)	H (HIGH)																																					
M+	M+	M+																																					
M (MED)	M (MED)	M+																																					
L+	L+	M (MED)																																					
L (LOW)	L (LOW)	L+																																					
	Normal heating	Heating of Auto cooling/heating																																					
L	UL (Ultra Low) only in Comp OFF	L+																																					
L+	L+	M (MED)																																					
M (MED)	M (MED)	M+																																					
M+	M+	M+																																					
H (HIGH)	H (HIGH)	H UH																																					

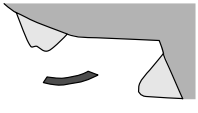
No.	Item	Outline of specifications	Remarks																																																											
5	Air volume control (Continued)	<table border="1" data-bbox="475 228 1078 748"> <thead> <tr> <th rowspan="2">Tap</th> <th colspan="2">Air volume setup</th> <th>SM560</th> <th>SM800</th> </tr> <tr> <th>COOL, DRY, FAN</th> <th>HEAT</th> <th colspan="2">Revolutions per minute (rpm)</th> </tr> </thead> <tbody> <tr> <td>F4</td> <td></td> <td>UH</td> <td>1290</td> <td>1480</td> </tr> <tr> <td>F5</td> <td></td> <td>H</td> <td>1230</td> <td>1480</td> </tr> <tr> <td>F6</td> <td>H</td> <td></td> <td>1180</td> <td>1340</td> </tr> <tr> <td>F7</td> <td>M+</td> <td>M+</td> <td>1150</td> <td>1320</td> </tr> <tr> <td>F8</td> <td></td> <td>M</td> <td>1120</td> <td>1310</td> </tr> <tr> <td>F9</td> <td>M</td> <td></td> <td>1060</td> <td>1200</td> </tr> <tr> <td>FA</td> <td></td> <td>L+</td> <td>1060</td> <td>1200</td> </tr> <tr> <td>FB</td> <td>L+</td> <td>L</td> <td>990</td> <td>1100</td> </tr> <tr> <td>FC</td> <td>L</td> <td></td> <td>940</td> <td>1040</td> </tr> <tr> <td>FD</td> <td></td> <td>UL</td> <td>900</td> <td>900</td> </tr> </tbody> </table> <p data-bbox="448 763 1102 1128"> 3) In heating operation, the mode changes to [Ultra Low (UL)] or [STOP] if thermostat is turned off. 4) If $T_a \geq 25^\circ\text{C}$ when heating operation has started and when defrost operation has been cleared, it operates with MED mode or higher mode for 1 minute from when T_c has entered in A zone of cool air discharge preventive control (Item 6). 5) In automatic cooling/heating operation, the revolution frequency of [HIGH (H)] is set larger than that in the standard cooling/heating operation. However the revolution frequency is restricted in the automatic heating operation as shown in the following figure. </p>  <p data-bbox="448 1458 1094 1554"> 6) (For wireless type only) The mode enters [AUTO] in automatic cooling/heating operation. 7) The mode enters [LOW (L)] during Dry operation </p>	Tap	Air volume setup		SM560	SM800	COOL, DRY, FAN	HEAT	Revolutions per minute (rpm)		F4		UH	1290	1480	F5		H	1230	1480	F6	H		1180	1340	F7	M+	M+	1150	1320	F8		M	1120	1310	F9	M		1060	1200	FA		L+	1060	1200	FB	L+	L	990	1100	FC	L		940	1040	FD		UL	900	900	<p data-bbox="1126 763 1445 920"> “Stop” is a “cool air discharge preventive control” operation by T_c. T_c: Indoor heat exchanger sensor temp. </p> <p data-bbox="1126 1458 1318 1487">Display: [AUTO]</p>
Tap	Air volume setup			SM560	SM800																																																									
	COOL, DRY, FAN	HEAT	Revolutions per minute (rpm)																																																											
F4		UH	1290	1480																																																										
F5		H	1230	1480																																																										
F6	H		1180	1340																																																										
F7	M+	M+	1150	1320																																																										
F8		M	1120	1310																																																										
F9	M		1060	1200																																																										
FA		L+	1060	1200																																																										
FB	L+	L	990	1100																																																										
FC	L		940	1040																																																										
FD		UL	900	900																																																										
6	Cool air discharge preventive control	<p data-bbox="448 1581 1062 1700"> 1) In heating operation, the indoor fan is controlled based on the detected temperature of T_c sensor. As shown below, the upper limit of the revolution frequency is determined. </p>  <p data-bbox="810 1720 1094 1854"> A zone : Setup air volume from remote controller B zone : Low air C zone : OFF </p>	<p data-bbox="1126 1671 1342 1700">Display in C zone</p> <p data-bbox="1126 1727 1390 1783">Display of main unit: Defrost LED goes on.</p> <p data-bbox="1126 1809 1445 1921">When wired remote controller is installed: PRE-HEAT/DEFROST goes on remote controller.</p>																																																											

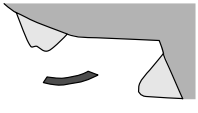
No.	Item	Outline of specifications	Remarks						
7	Freeze preventive control (Low temperature release)	<p>1) The cooling operation (including Dry operation) is performed as follows based on the detected temperature of Tc sensor or Tcj sensor.</p> <p>When [J] zone is detected for T1 minutes (Following figure), the commanded frequency is decreased from the real operation frequency. After then the commanded frequency changes every 30 seconds while operation is performed in [J] zone.</p> <table border="1" data-bbox="639 472 903 600"> <thead> <tr> <th colspan="2" data-bbox="751 472 903 510">T1</th> </tr> </thead> <tbody> <tr> <td data-bbox="639 510 751 548">Normal</td> <td data-bbox="751 510 903 548">6 minutes</td> </tr> <tr> <td data-bbox="639 548 751 600">Twin</td> <td data-bbox="751 548 903 600">6 minutes</td> </tr> </tbody> </table> <p>In [K] zone, time counting is interrupted and the operation is held.</p> <p>When [I] zone is detected, the timer is cleared and the operation returns to the normal operation.</p> <p>If the commanded frequency becomes S0 because the operation continues in [J] zone, the return temperature A is raised from 5°C to 12°C until [I] zone is detected and the indoor fan operates with [L] mode.</p>  <p>In heating operation, the freeze-preventive control works if 4-way valve is not exchanged and the condition is satisfied.</p>	T1		Normal	6 minutes	Twin	6 minutes	Tcj : Indoor heat exchanger sensor temperature
T1									
Normal	6 minutes								
Twin	6 minutes								
8	High-temp release control	<p>1) The heating operation is performed as follows based on the detected temperature of Tc sensor.</p> <ul style="list-style-type: none"> When [M] zone is detected, the commanded frequency is decreased from the real operation frequency. After then the commanded frequency changes every 30 seconds while operation is performed in [M] zone. In [N] zone, the commanded frequency is held. When [L] zone is detected, the commanded frequency is returned to the original value by approx. 6Hz every 60 seconds. <p>Setup at shipment</p> <table border="1" data-bbox="472 1704 700 1832"> <thead> <tr> <th colspan="2" data-bbox="472 1704 700 1742">Control temp (°C)</th> </tr> </thead> <tbody> <tr> <td data-bbox="472 1742 584 1780">A</td> <td data-bbox="584 1742 700 1780">B</td> </tr> <tr> <td data-bbox="472 1780 584 1832">56 (54)</td> <td data-bbox="584 1780 700 1832">52 (52)</td> </tr> </tbody> </table>  <p>NOTE : When the operation has started or when Tc became lower than 30°C after start of the operation, temperature is controlled between values in parentheses of A and B.</p>	Control temp (°C)		A	B	56 (54)	52 (52)	Same when thermostat is turned off.
Control temp (°C)									
A	B								
56 (54)	52 (52)								

No.	Item	Outline of specifications	Remarks				
9	Louver control 1) Louver position 2) Air direction adjustment (Swing operation)	<p>The louver angle is displayed setting 0° as "Full close".</p>  <p>1) In the initial operation after power-ON, the position is automatically controlled according to the operating status (COOL/HEAT).</p> <table border="1" data-bbox="619 551 1085 757"> <tr> <td data-bbox="619 551 850 600">Cooling</td> <td data-bbox="850 551 1085 600">Heating</td> </tr> <tr> <td data-bbox="619 600 850 757">  </td> <td data-bbox="850 600 1085 757">  </td> </tr> </table> <p>2) After then a louver position is stored in the microcomputer every time when position is operated on the remote controller, and the louver operates at the position stored in memory in the next operation and after.</p> <p>* If the operation mode has been changed from COOL to HEAT, from HEAT to COOL, or the power has turned off, the stored louver position is cleared and the status returns to one in item 1).</p> <p>1) When pushing [LOUVER] button during operation, the louver starts swinging. 2) When the louver has arrived at the desired position, push [LOUVER] again. The louver stops at that position.</p>	Cooling	Heating			
Cooling	Heating						
							
10	Frequency fixed operation (Test run)	<p>1) In case of wired remote controller</p> <ol style="list-style-type: none"> When pushing [ON/OFF] button on the remote controller continuously for 5 seconds, the mode enters [TEST]. The indoor fan rotates with [HIGH] and a frequency fixed operation starts. During this operation, the buttons other than [ON/OFF], [UP] and [DOWN] cannot be accepted. However, items 7 and 8 are effective. To stop the frequency fixed operation, use [ON/OFF] button only. <p>2) In case of wireless remote controller (Without wired remote controller)</p> <ol style="list-style-type: none"> When pushing [Temporary] button continuously for 10 seconds or more, "Pi" sound is heard and the mode enters [TEST]. The indoor fan rotates with [HIGH] and a frequency fixed operation of [COOL] starts. <p>NOTES :</p> <ul style="list-style-type: none"> Temporary button is provided to near the display part of the main unit when opening the front panel. If [Temporary] button is not continuously pushed for 10 seconds, "Automatic heating/cooling operation" is performed. <ol style="list-style-type: none"> To stop the operation, push [Temporary] button again. <p>NOTE : Operation on the wireless remote controller is not accepted.</p>	<p>[COOL]/[HEAT] flash. Air volume: [AUTO] Temperature COOL: [L] HEAT: [H]</p> <p>Commanded frequency Approximately [S7]</p>				

No.	Item	Outline of specifications	Remarks												
11	Filter sign display	<p>1) The operation time of the indoor fan is calculated, the filter lamp (Orange) on the display part of the main unit goes on when the specified time (240H) has passed. When a wired remote controller is connected, the filter reset signal is sent to the remote controller, and also it is displayed on LCD of the wired remote controller.</p> <p>2) When the filter reset signal has been received from the wired remote controller after [FILTER] lamp has gone on or when the filter check button (Temporary button) is pushed, time of the calculation timer is cleared. In this case, the measurement time is reset if the specified time has passed, and display on LCD and the display on the main unit disappear.</p>	[FILTER] goes on.												
12	Central control mode selection	<p>1) Setting at the central remote controller side enables to select the contents which can be operated on the remote controller at indoor unit side.</p> <p>2) Operation contents on the remote controller at indoor unit side</p> <p>[Last push priority] : The operation contents can be selected from both remote controller and the central controller of the indoor unit side, and the operation is performed with the contents selected at the last.</p> <p>[Center] : Start/Stop operation only can be handled on the remote controller at indoor unit side.</p> <p>[Operation Prohibited] : It cannot be operated on the remote controller at indoor unit side. (Stop status is held.)</p> <p>3) Display on the display part of the main unit or wired remote controller</p> <table border="1" style="width: 100%; border-collapse: collapse;"> <tr> <td style="width: 25%;">Setup on central control remote controller Last push priority</td> <td style="width: 25%;">Display on wired remote controller (In case of RBC-AM1) [Central control] goes off.</td> <td style="width: 25%;">Display on wired remote controller (In case of RBC-AM1) [Center] goes off.</td> <td style="width: 25%;">Display on main unit (Only in case of no wired remote controller) No display</td> </tr> <tr> <td>Center</td> <td>[Central control] goes on.</td> <td>[Center] goes on.</td> <td>[DEFROST] lamp (Orange) 1Hz flashes.</td> </tr> <tr> <td>Operation prohibited</td> <td>[Central control] flashes.</td> <td>[Center] flashes.</td> <td>[DEFROST] lamp (Orange) 5Hz flashes.</td> </tr> </table> <p>NOTE : When a wired remote controller is connected, there is no display on the main unit.</p>	Setup on central control remote controller Last push priority	Display on wired remote controller (In case of RBC-AM1) [Central control] goes off.	Display on wired remote controller (In case of RBC-AM1) [Center] goes off.	Display on main unit (Only in case of no wired remote controller) No display	Center	[Central control] goes on.	[Center] goes on.	[DEFROST] lamp (Orange) 1Hz flashes.	Operation prohibited	[Central control] flashes.	[Center] flashes.	[DEFROST] lamp (Orange) 5Hz flashes.	
Setup on central control remote controller Last push priority	Display on wired remote controller (In case of RBC-AM1) [Central control] goes off.	Display on wired remote controller (In case of RBC-AM1) [Center] goes off.	Display on main unit (Only in case of no wired remote controller) No display												
Center	[Central control] goes on.	[Center] goes on.	[DEFROST] lamp (Orange) 1Hz flashes.												
Operation prohibited	[Central control] flashes.	[Center] flashes.	[DEFROST] lamp (Orange) 5Hz flashes.												
13	Energy-save control (By connected outdoor unit)	<p>1) Selecting [AUTO] mode enables an energy-saving to be operated.</p> <p>2) The setup temperature is shifted (corrected) in the range not to lose the comfort ability according to input values of various sensors.</p> <p>3) Data (Input value room temp. Ta, Outside temp. To, Air volume, Indoor heat exchanger sensor temp. Tc) for 20 minutes are taken the average to calculate correction value of the setup temperature.</p> <p>4) The setup temperature is shifted every 20 minutes, and the shifted range is as follows. In cooling time : +1.5 to -1.0K In heating time : -1.5 to +1.0K</p>													
14	Max. frequency cut control	<p>1) This control is operated by selecting [AUTO] operation mode.</p> <p>2) COOL operation mode: the frequency is controlled according to the following figure if To < 28°C.</p> <p>3) HEAT operation mode: the frequency is controlled according to the right figure if To > 15°C.</p>													

9-2. Indoor Control Circuit

9-2-1. Print Circuit Board

<Main P.C. board (MCC-1370A)>

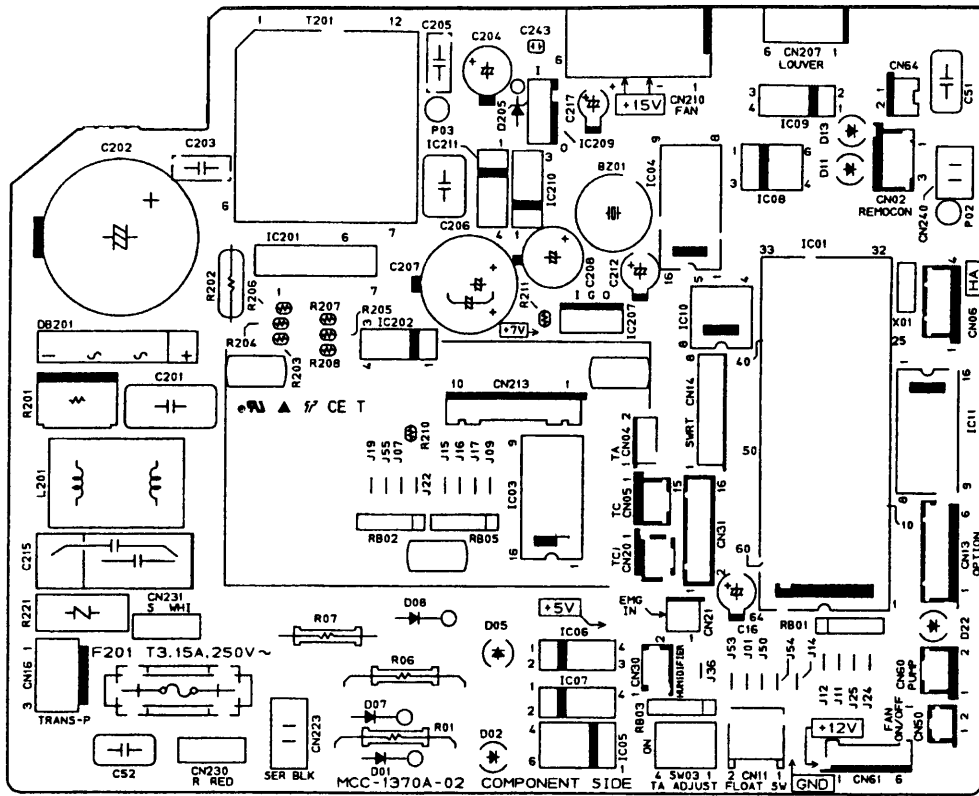

<Sub P.C. board (MCC-1370B)>

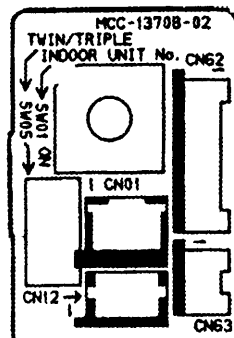

9-2-2. Outline of Main Controls

1. Pulse Modulating Valve (PMV) control

- 1) For PMV, SM560 is controlled with 45 to 500 pulses and SM800 with 50 to 500 pulses during operation, respectively.
- 2) In cooling operation, PMV is controlled with the temperature difference between TS sensor and TC sensor.
- 3) In heating operation, PMV is controlled with the temperature difference between TS sensor and TE sensor.
- 4) For the temperature difference in items 2) and 3), 1 to 5K is aimed as the target in both cooling and heating operations.
- 5) When the cycle excessively rose in both cooling and heating operations, PMV is controlled by TD sensor. The aimed value is usually 105°C for SM560 and 100°C for SM800 in both cooling and heating operations.

REQUIREMENT

A sensor trouble may cause a liquid back-flow or abnormal overheat resulting in excessive shortening of the compressor life. In a case of trouble on the compressor, be sure to check there is no error in the resistance value an the refrigerating cycle of each sensor after repair and then start the operation.

2. Discharge temperature release control

- 1) This function controls the operation frequency, that is, lowers the operation frequency when the discharge temperature has not lower or the discharge temperature has rapidly risen during PMV control. It subdivides the frequency control up to a unit of 0.6Hz to stabilize the cycle.
 - 2) When the discharge temperature is detected in an abnormal stop zone, the unit stops the compressor and restarts after 2 minutes 30 seconds. The error counter is cleared when it has continued the operation for 10 minutes. If the abnormal stop zone has been detected by 4 times without clearing of counter, an error 'P03' is displayed.
- * The cause is considered as excessively little amount of refrigerant, defective PMV, or clogging of cycle.

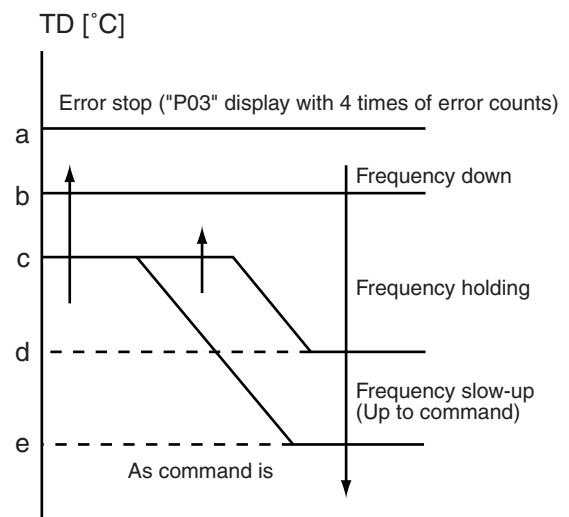

[°C]

	a	b	c	d	e
SM560	117	112	108	105	98
SM800	111	106	100	95	90

3. Current release control

The output frequency and the output voltage are controlled by AC current value detected by T02 on the outdoor P.C. board so that input current of the inverter does not exceed the specified value.

Objective model	SM560		SM800	
	COOL	HEAT	COOL	HEAT
I1 value [A]	9.22	11.93	12.00	13.43

* For the cooling only models, only COOL is objective.

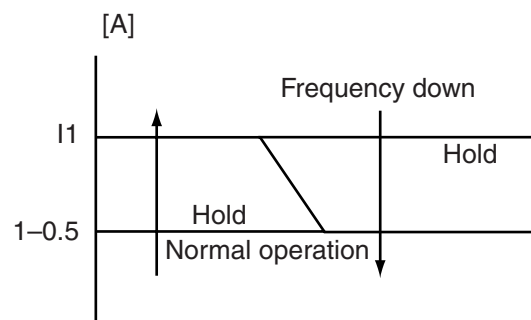

9-2-3. Indoor P.C. Board Optional Connector Specifications

Function	Connector No.	Pin No.	Specifications	Remarks
Option output	CN60	1	DC12V (COM)	
		2	Defrost output	ON during defrost operation of outdoor unit
		3	Thermo. ON output	ON during Real thermo-ON (Comp ON)
		4	Cooling output	ON when operation mode is in cooling system (COOL, DRY, COOL in AUTO cooling/heating)
		5	Heating output	ON when operation mode is in heating system (HEAT, HEAT in AUTO cooling/heating)
		6	Fan output	ON during indoor fan ON (Air purifier is used/Interlock cable)
Outside error input	CN80	1	DC12V (COM)	(When continued for 1 minute) Check code "L30" is output and forced operation stops.
		2	DC12V (COM)	
		3	Outside error input	
Filter option error	CN70	1	Filter/Option/Humidifier setup input	Option error input is controlled. (Protective operation for device attached to outside is displayed.)
		2	0V	* Setting of option error input is performed from remote controller. (DN=2A)
CHK Operation check	CN71	1	Check mode input	Used for operation check of indoor unit. (Communication with outdoor unit or remote controller is not performed, but the specified operation such as indoor fan "H" or drain pump ON is output.)
		2	0V	
DISP display mode	CN72	1	Display mode input	Display mode enables indoor unit and remote controller to communicate. (When power is turned on)
		2	0V	
EXCT demand	CN73	1	Demand input	Forced thermo-OFF operation in indoor unit
		2	0V	

9-3. Outdoor Controls

9-3-1. Print Circuit Board

<Viewed from parts of P.C board>

MCC-813 (RAV-SM560AT-E)

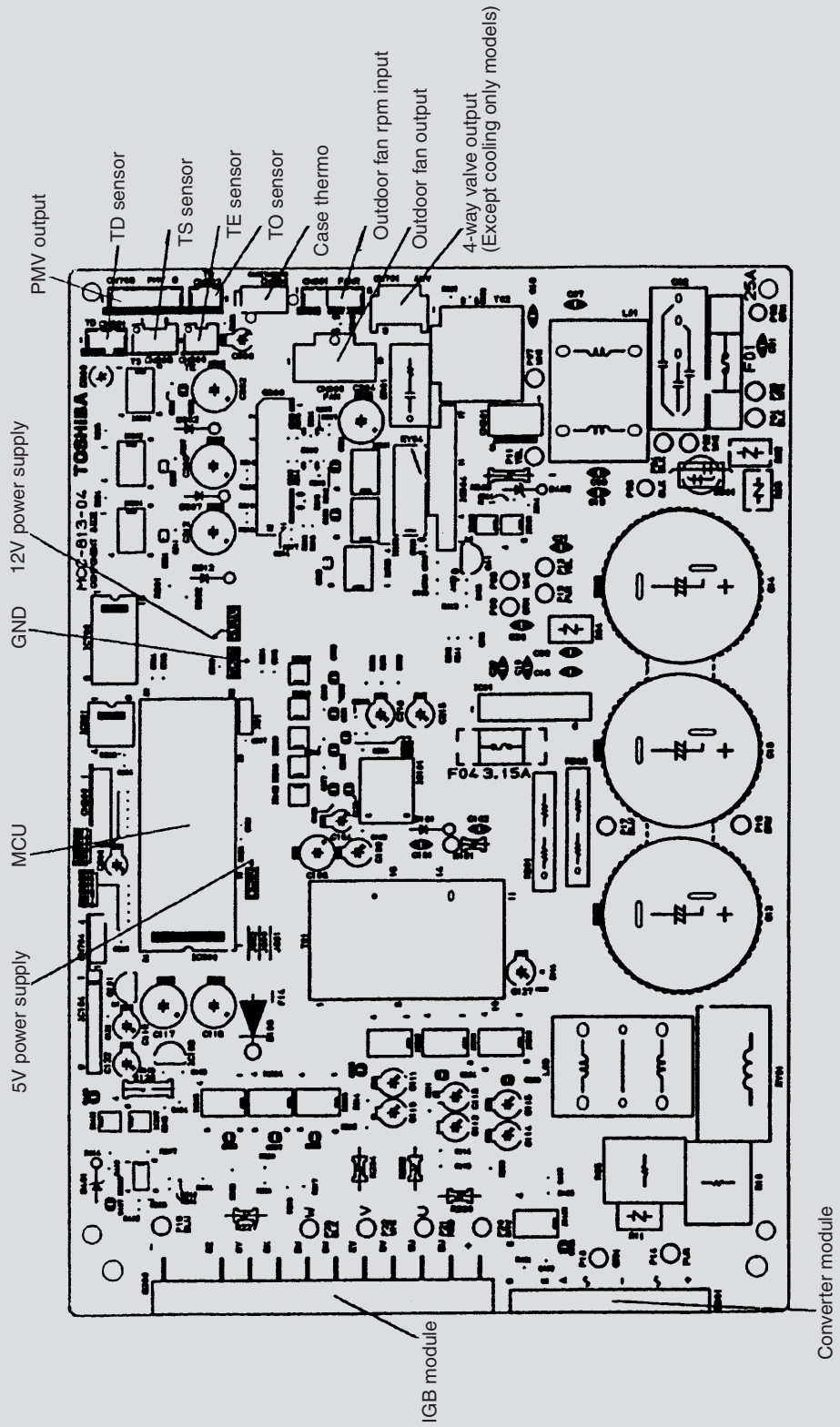

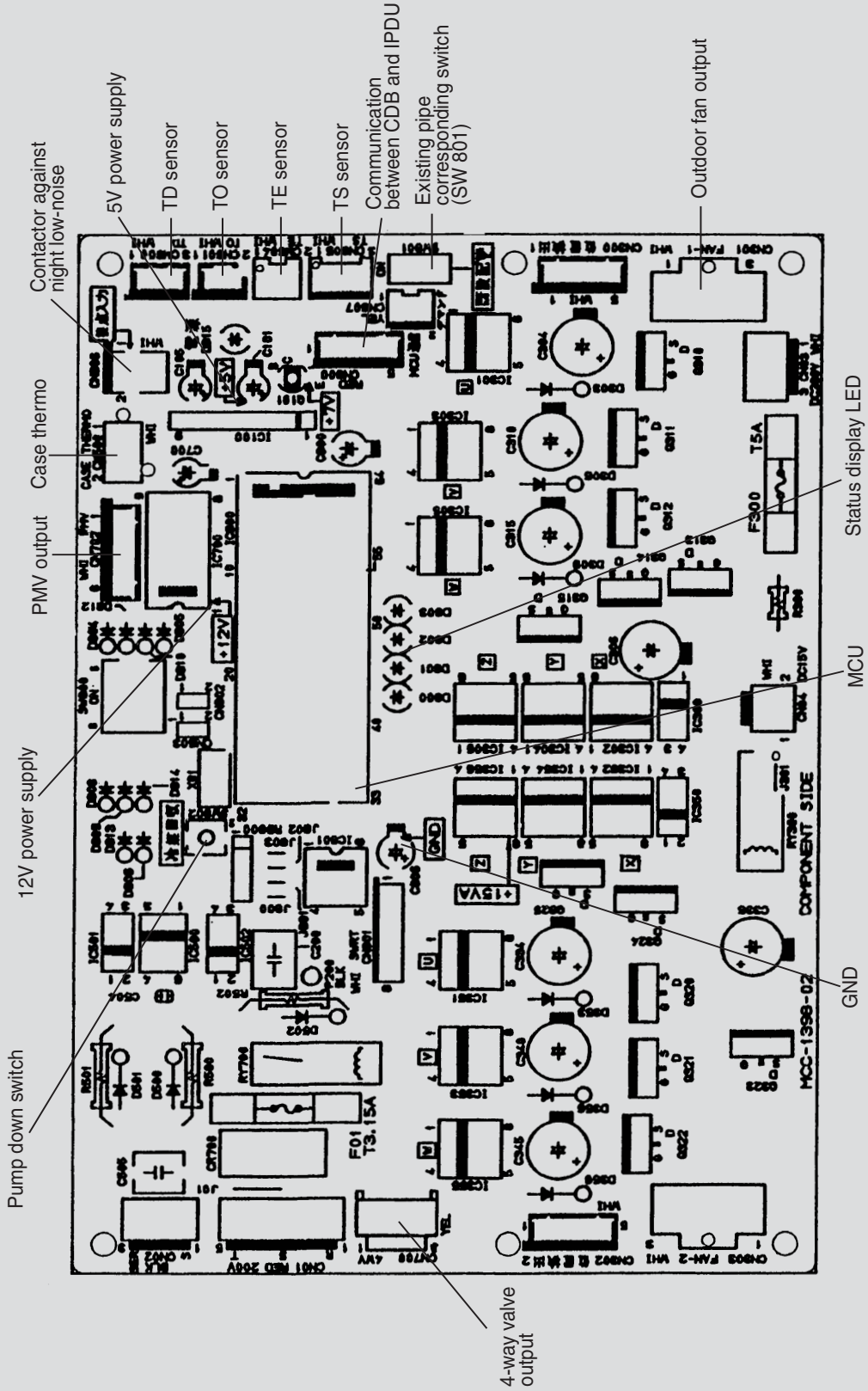

9-3-2. Outline of Main Controls

1. Outdoor fan control (Object: SM80)

Allocations of fan tap revolutions [rpm]

	W1	W2	W3	W4	W5	W6	W7	W8	W9	WA	WB	WC	WD	WE
SM800	250	270	290	310	340	370	400	440	480	520	560	610	700	780

1) Cooling fan control

- ① The outdoor fan is controlled by TE sensor.
(Cooling: Temperature conditions after medium term)
The cooling fan is controlled by every 1 tap of DC fan control (14 taps).
- ② At the activation time, although the maximum fan tap in the following table are fixed for 60 seconds, after then the fan may not rotate with high speed for several minutes because the fan is controlled by TE sensor value. It is not an abnormal status.
- ③ When the discharge temperature sensor is abnormal or the sensor comes off the holder, the fan does not rotate with high speed, but a protective device works.
- ④ When the outdoor fan does not rotate with high speed, judge a fan error by comparing the control data in the following table with TO and TE values.

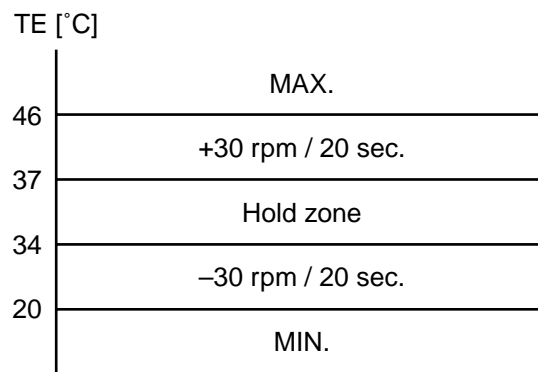

Control for fan tap by outdoor temperature in normal operation

TO	TO < 5°C	5 ≤ TO < 10°C	10 ≤ TO < 15°C	15 ≤ TO < 20°C	20 ≤ TO < 25°C	25°C ≤ TO	TO error
MIN	W1	W2	W3	W4	W5	WA	W1
MAX	W6	W8	WA	WC	WE	WE	WE

2) Heating fan control

- ① This control function lowers fan tap according to TE sensor value when outdoor temperature is high.
- ② When a status TE > 20°C is detected continuously for 5 minutes, the operation may stop. This status does not output an error code and is assumed as usual status of thermo-OFF. The fan restarts after approx. 2 minutes 30 seconds and this intermittent operation is not a trouble.
- ③ If the status in item ② is frequently found, it is considered that the filter of suction part of the indoor unit is dirty. Clean the filter and restart the operation.
- ④ This control function does not work for 30 minutes after activation, 1 minute after defrosting, and during defrost operation.

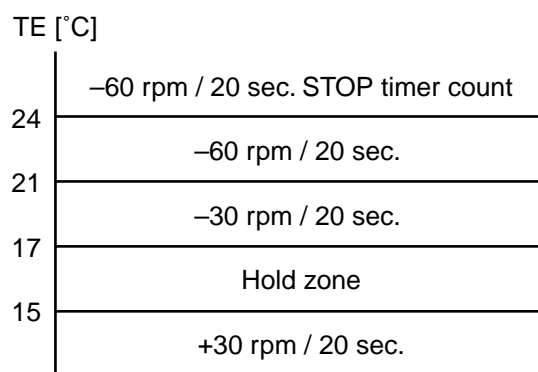

2. Outdoor fan control (Object: SM560)

The outdoor fan is controlled by TO sensor and the revolutions frequency of the compressor (rps).

The outdoor fan is controlled by every 1 tap of DC fan control (8 taps). According to each operation mode, the fan is operated by selecting an outdoor fan operation tap in the following table based upon the conditions of TO sensor and the compressor operation (rps).

Allocations of fan tap revolutions

Tap		F1	F2	F3	F4	F5	F6	F7	F8
SM560	Revolutions per minute (rpm)	960	870	870	870	750	700	540	390

In cooling operation

Frequency of the compressor (rps)	To 14	To 14	35 to MAX
TO ≥ 38°C	F7	F4	F3
TO < 38°C	F7	F5	F4

In heating operation

Frequency of the compressor (rps)	To 14	To 14	35 to MAX
TO ≥ 5.5°C	F7	F6	F4
TO < 5.5°C	F6	F6	F3

3. Coil heating control

- 1) This control function heats the compressor by turning on the stopped compressor instead of a case heater. It purposes to prevent slackness of the refrigerant inside of the compressor.
- 2) As usual, turn on power of the compressor for the specified time before a test run after installation, otherwise a trouble of the compressor may be caused. As same as a test run, it is recommended to turn on power of the compressor beforehand when starting operation after power of the compressor has been interrupted for a long time.
- 3) A judgment for electricity is performed by TD and TO sensors. If TO sensor is defective, a backup control is automatically performed by TE sensor. For a case of defective TO sensor, judge it with the outdoor LED display.
- 4) Coil heating is controlled by TD and TE sensor.
- 5) For every model, the power is turned off when TD is 30°C or more.

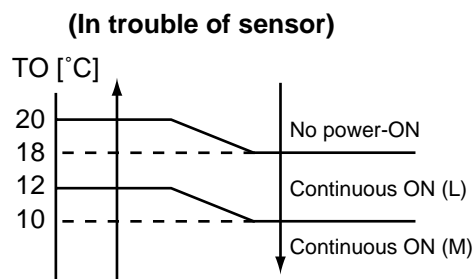
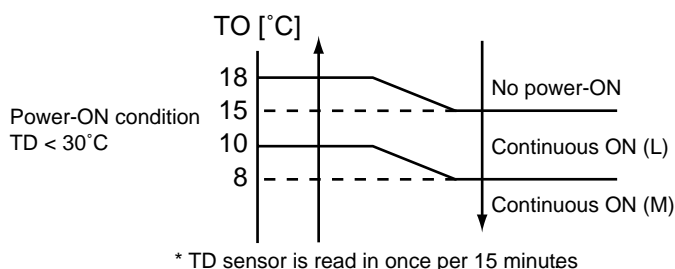

(Object: SM560)

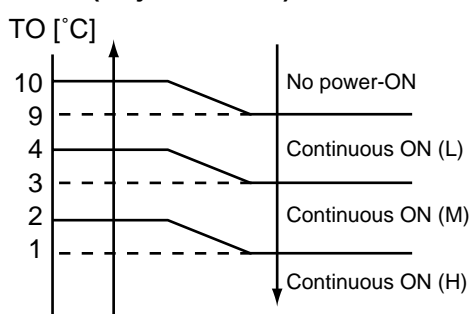

SM800	
L	20W and equivalent
M	40W and equivalent

SM560	
L	10W and equivalent
M	20W and equivalent
H	30W and equivalent

NOTIFICATION

It is not an abnormal phenomenon that electro-noise may be heard while heating the coil.

4. Short intermittent operation preventive control

- ① The compressor may not stop for preventing the compressor for 3 to 10 minutes after start of the operation even if Thermo-OFF signal has been received from the indoor. This phenomenon is not abnormal. (Continuous operation time of the compressor differs according to the operating status.)
- ② If the equipment is stopped from the remote controller, the operation does not continue.

5. High-voltage suppression TE control (Only for SM800)

- ① This control suppresses that voltage becomes abnormally higher during cooling operation.
- ② Stop the compressor under condition of $TE \geq 67^\circ\text{C}$, and count 1 on the error count.
- ③ After 2 minutes 30 seconds passed, if $TE < 67^\circ\text{C}$, the compressor restarts and the error count is cleared when the operation continues for 10 minutes.
- ④ When $TE \geq 67^\circ\text{C}$ is detected again within 10 minutes, 1 is added to the error count and restart is repeated.
- ⑤ If the error counts 10 are recognized, it is determined as an error and restart is not performed. Error code 'P04' is displayed.
- ⑥ After restarting the compressor, continue controlling by using 70% to 90% of the control value of the current release control for minimum 30 minutes.

6. Over-current preventive control

- ① This control function stops the compressor when over-current preventive circuit has detected an abnormal current.
- ② The compressor restarts with error count 1 after 2 minutes 30 seconds.
- ③ If the error counts 4 are recognized, it is determined as an error and restart is not performed. Error code 'H01', 'H02' or 'P26' is displayed.

7. Current release value shift control

1) Object: SM800

- ① This control function prevents troubles of the electron parts such as G-Tr of inverter of compressor drive system and troubles of the compressor during cooling operation.
- ② This control function corrects the current release control value (I1) in item 3 of 9-2-2 by TO sensor value.
- ③ The value to be corrected is based upon the following control diagram and correction value table.

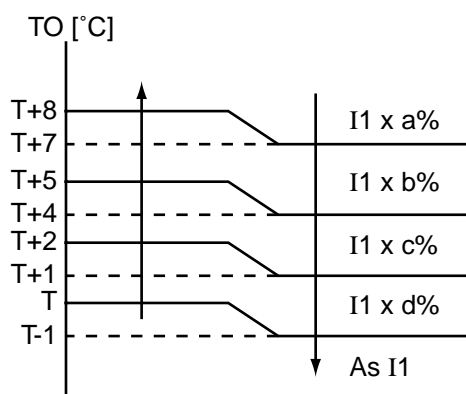

Corrected value

SM800	T	a	b	c	d
	39°C	40%	60%	80%	85%

2) Object: SM560

The current release value of a single-phase model is selected from the right table according to TO sensor value.

Current release value shift control

TO	SM560
$45 \leq TO$	6.07
$40 \leq TO < 45$	6.90
$TO < 40$	9.22

8. Defrost control

- ① In heating operation, defrost operation is performed when TE sensor temperature satisfies any condition in A zone to D zone.
- ② The defrost operation is immediately finished if TE sensor temperature has become 12°C or more, or it also is finished when condition of $7^{\circ}\text{C} \leq \text{TE} < 12^{\circ}\text{C}$ has continued for 1 minute. The defrost operation is also finished when defrost operation has continued for 10 minutes even if TE sensor temperature has become 7°C or lower.
- ③ After defrost operation has finished, the compressor and the outdoor fan start heating operation after stopped for approx. 50 seconds.

Start of heating operation

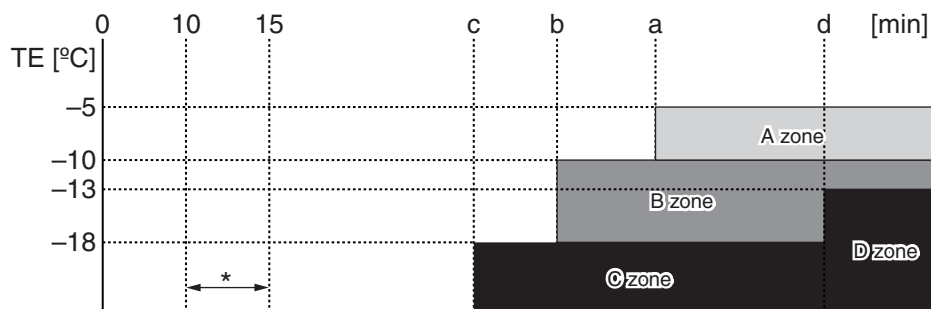

* The minimum TE value between 10 and 15 minutes after heating operation has started is stored in memory as TE0.

A zone	Defrost operation is performed in this zone when $\text{TE0} - \text{TE} \geq 3$ continued for T seconds.
B zone	Defrost operation is performed in this zone when $\text{TE0} - \text{TE} \geq 3$ continued for T seconds.
C zone	Defrost operation is performed when this zone continued for T seconds.
D zone	Defrost operation is performed when this zone continued for T seconds.

	SM560	SM800
a	28	34
b	28	40
c	28	55
d	60	90
T	120	120

10. TROUBLESHOOTING

10-1. Summary of Troubleshooting

<Wired remote controller type>

1. Before troubleshooting

1) Required tools/instruments

- ⊕ and ⊖ screwdrivers, spanners, radio cutting pliers, nippers, push pins for reset switch
- Tester, thermometer, pressure gauge, etc.

2) Confirmation points before check

① The following operations are normal.

a) Compressor does not operate.

- Is not 3-minutes delay (3 minutes after compressor OFF)?
- Does not thermostat turn off?
- Does not timer operate during fan operation?
- Is not outside high-temperature operation controlled in heating operation?

b) Indoor fan does not rotate.

- Does not cool air discharge preventive control work in heating operation?

c) Outdoor fan does not rotate or air volume changes.

- Does not high-temperature release operation control work in heating operation?
- Does not outside low-temperature operation control work in cooling operation?
- Is not defrost operation performed?

d) ON/OFF operation cannot be performed from remote controller.

- Is not the control operation performed from outside/remote side?
- Is not automatic address being set up?

(When the power is turned on at the first time or when indoor unit address setting is changed, the operation cannot be performed for maximum approx. 5 minutes after power-ON.)

② Did you return the cabling to the initial positions?

③ Are connecting cables of indoor unit and remote controller correct?

(2) Troubleshooting procedure

When a trouble occurred, check the parts along with the following procedure.

Trouble → **Confirmation of check code display** → **Check defective position and parts.**

NOTE :

For cause of a trouble, power conditions or malfunction/erroneous diagnosis of microcomputer due to outer noise is considered except the items to be checked. If there is any noise source, change the cables of the remote controller to shield cables.

<Wireless remote controller type> (Only for 4-way air discharge cassette type models)

1. Before troubleshooting

- 1) Required tools/instruments
 - ⊕ and ⊖ screwdrivers, spanners, radio cutting pliers, nippers, etc.
 - Tester, thermometer, pressure gauge, etc.
- 2) Confirmation points before check
 - ① The following operations are normal.
 - a) Compressor does not operate.
 - Is not 3-minutes delay (3 minutes after compressor OFF)?
 - Does not thermostat turn off?
 - Does not timer operate during fan operation?
 - Is not outside high-temperature operation controlled in heating operation?
 - b) Indoor fan does not rotate.
 - Does not cool air discharge preventive control work in heating operation?
- 3) Outdoor fan does not rotate or air volume changes.
 - Does not high-temperature release operation control work in heating operation?
 - Does not outside low-temperature operation control work in cooling operation?
 - Is not defrost operation performed?
- 4) ON/OFF operation cannot be performed from remote controller.
 - Is not forced operation performed?
 - Is not the control operation performed from outside/remote side?
 - Is not automatic address being set up?
 - ① Did you return the cabling to the initial positions?
 - ② Are connecting cables between indoor unit and receiving unit correct?

2. Troubleshooting procedure

(When the power is turned on at the first time or when indoor unit address setting is changed, the operation cannot be performed for maximum approx. 5 minutes after power-ON.)

When a trouble occurred, check the parts along with the following procedure.

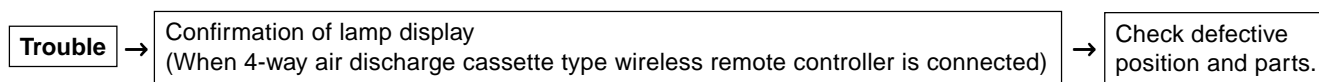

1) Outline of judgment

The primary judgment to check where a trouble occurred in indoor unit or outdoor unit is performed with the following method.

Method to judge the erroneous position by flashing indication on the display part of indoor unit (sensors of the receiving unit)

The indoor unit monitors operating status of the air conditioner, and the blocked contents of self-diagnosis are displayed restricted to the following cases if a protective circuit works.

10-2. Check Code List

Error mode detected by indoor unit

: Flash, : Go on, : Go off

Wireless sensor lamp display		Wired remote controller		Diagnostic function				Judgment and measures	
Operation	Timer	Ready	Check code	Cause of operation	Status of air conditioner	Condition			
			E03	No communication from remote controller (including wireless) and communication adapters	Stop (Automatic reset)	Displayed when error is detected	1. Check cables of remote controller and communication adapters. • Handy remote controller LCD display OFF (Disconnection) • Central remote controller [97] check code		
			E04	The serial signal is not output from outdoor unit to indoor unit. • Miscabling of inter-unit cables • Defective serial sensing circuit on outdoor P.C. board • Defective serial receiving circuit on indoor P.C. board	Stop (Automatic reset)	Displayed when error is detected	1. Outdoor unit does not completely operate. • Inter-unit cable check, correction of miscabling, case thermo operation • Outdoor P.C. board check, P.C. board cables check 2. In normal operation P.C. board (Indoor receiving/Outdoor sending) check		
			E08	Duplicated indoor unit addresses	Stop	Displayed when error is detected	1. Check whether there is modification of remote controller connection (Group/Individual) or not after power has been turned on (finish of group configuration/address check). * If group configuration and address are not normal when the power has been turned on, the mode automatically shifts to address setup mode. (Resetting of address)		
			L03	Duplicated indoor master units	Stop	Displayed when error is detected	1. Set the indoor capacity. (DN=11)		
			L07	There is group line in individual indoor units.	Stop	Displayed when error is detected	1. Check outside devices. 2. Check indoor P.C. board.		
			L08	Unsetting of indoor group address	Stop	Displayed when error is detected	1. Check thermal relay of fan motor. 2. Check indoor P.C. board.		
			L09	Unset indoor capacity	Stop	Displayed when error is detected	1. Defect of drain pump 2. Clogging of drain pump 3. Check float switch. 4. Check indoor P.C. board.		
			L30	Abnormal outside interlock input	Stop	Displayed when error is detected	1. Defective detection of position 2. Over-current protective circuit of indoor fan driving unit operates. 3. Lock of indoor fan 4. Check indoor P.C. board.		
			P01	Fan motor thermal protection	Stop	Displayed when error is detected	1. Check 4-way valve. 2. Check indoor heat exchanger (TC/TC-J) sensor. 3. Check indoor P.C. board.		
			P10	Float switch operation • Disconnection, coming-off, defective float switch contactor of float circuit	Stop	Displayed when error is detected	1. Judge sub unit while master unit is in [E03], [L03], [L07], [L08]. 2. Check indoor P.C. board.		
			P12	Indoor DC fan error	Stop	Displayed when error is detected	1. Check indoor heat exchanger temperature sensor (TC-J). 2. Check indoor P.C. board.		
			P19	Error in 4-way valve system • Indoor heat exchanger temperature lowered after start of heating operation.	Stop (Automatic reset)	Displayed when error is detected	1. Check indoor heat exchanger temperature sensor (TC). 2. Check indoor P.C. board.		
			P31	Own unit stops while warning is output to other indoor units.	Stop (Sub unit) (Automatic reset)	Displayed when error is detected	1. Check indoor heat exchanger temperature sensor (TC). 2. Check indoor P.C. board.		
			F01	Coming-off, disconnection or short of indoor heat exchanger sensor (TC-J)	Stop (Automatic reset)	Displayed when error is detected	1. Check indoor heat exchanger temperature sensor (TC). 2. Check indoor P.C. board.		
			F02	Coming-off, disconnection or short of indoor heat exchanger sensor (TC)	Stop (Automatic reset)	Displayed when error is detected	1. Check indoor heat exchanger temperature sensor (TC). 2. Check indoor P.C. board.		
			F10	Coming-off, disconnection or short of indoor heat exchanger sensor (TA)	Stop (Automatic reset)	Displayed when error is detected	1. Check indoor heat exchanger temperature sensor (TA). 2. Check indoor P.C. board.		
			F29	Indoor EEPROM error • EEPROM access error	Stop (Automatic reset)	Displayed when error is detected	1. Check indoor EEPROM. (including socket insertion) 2. Check indoor P.C. board.		
			E10	Communication error between indoor MCU • Communication error between fan driving MCU and main MCU	Stop (Automatic reset)	Displayed when error is detected	1. Check cables of remote controller. 2. Check power cables of indoor unit. 3. Check indoor P.C. board.		
			E18	Regular communication error between master and sub indoor units or between main and sub indoor units	Stop (Automatic reset)	Displayed when error is detected	1. Check cables of remote controller. 2. Check indoor power cable. 3. Check indoor P.C. board.		

Error mode detected by outdoor unit

: Flash, : Go on, : Go off

Wireless sensor lamp display		Wired remote controller		Diagnostic function			Judgment and measures
		Operation	Ready	Check code	Cause of operation	Status of air conditioner	
				H01	Breakdown of compressor • Displayed when error is detected	Stop	Displayed when error is detected 1. Check power voltage. AC200V±20V 2. Overload operation of refrigerating cycle 3. Check current detection circuit at AC side.
				H02	Compressor does not rotate. • Over-current protective circuit operates after specified time passed when compressor had been activated.	Stop	Displayed when error is detected 1. Trouble of compressor (Compressor lock, etc.) : Replace compressor. 2. Defective cabling of compressor (Phase missing) 3. Phase-missing operation of power supply (3-phase model)
				H03	Current detection circuit error • Current value at AC side is high even during compressor-OFF. • Phase of power supply is missed.	Stop	Displayed when error is detected 1. Compressor immediately stops even if restarted. : Check IPDU. 2. Phase-missing operation of power supply Check 3-phase power voltage and cables.
				L29	Outdoor unit and other errors • Communication error between CDB and IPDU (Coming-off of connector) • Heat sink temperature error (Detection of temperature over specified value)	Stop	Displayed when error is detected 1. Check cables of CDB and IPDU. 2. Abnormal overload operation of refrigerating cycle
				L31	Phase detection protective circuit operates. (Normal models)	Operation continues. (Compressor stops.)	Displayed when error is detected 1. Check power phase order (Reversed phase)/phase missing. 2. Check outdoor P.C. board.
				P03	Discharge temperature error • Discharge temperature over specified value was detected.	Stop	Displayed when error is detected 1. Check refrigerating cycle. (Gas leak) 2. Trouble of PMV 3. Check Td sensor.
				P04	High-pressure protection error by TE sensor (Temperature over specified value was detected.)	Stop	Displayed when error is detected 1. Overload operation of refrigerating cycle 2. Check outdoor temperature sensor (TE). 3. Check outdoor CDB P.C. board.
				P22	Outdoor DC fan error	Stop	Displayed when error is detected 1. Defective detection of position 2. Over-current protective circuit of outdoor fan driving unit operates. 3. Lock of outdoor fan 4. Check outdoor CDB P.C. board.
				P26	Inverter over-current protective circuit operates. (For a short time) Short voltage of main circuit operates.	Stop	Displayed when error is detected 1. Inverter immediately stops even if restarted. : Compressor motor rare short 2. Check IPDU : Cabling error
				P29	IPDU position detection circuit error	Stop	Displayed when error is detected 1. Position detection circuit operates even if operating compressor by removing 3P connector. : Replace IPDU.
				F04	Coming-off, disconnection or short of outdoor temperature sensor (TD)	Stop	Displayed when error is detected 1. Check outdoor temperature sensor (TD). 2. Check outdoor CDB P.C. board.
				F06	Coming-off, disconnection or short of outdoor temperature sensor (TE/TS)	Stop	Displayed when error is detected 1. Check outdoor temperature sensor (TE/TS). 2. Check outdoor CDB P.C. board.
				F08	Coming-off, disconnection or short of outdoor temperature sensor (TO)	Operation continues.	Displayed when error is detected 1. Check outdoor temperature sensor (TO). 2. Check outdoor CDB P.C. board.

For an error mode detected in outdoor unit, the fan operates because sub unit of a group operation does not communicate with the outdoor unit.

Error mode detected by remote controller or network adapter

: Flash, : Go on, : Go off

Wireless sensor lamp display		Wired remote controller		Diagnostic function			Judgment and measures
		Operation	Ready	Cause of operation	Status of air conditioner	Condition	
—	—	No check code is displayed. (Remote controller does not operate.)	—	No communication with master indoor unit • Remote controller cable is not correctly connected. • Power of indoor unit is not turned on. • Automatic address cannot be completed.	Stop	—	Remote controller power error, Defective indoor EEPROM 1. Check remote controller inter-unit cables. 2. Check remote controller. 3. Check indoor power cables. 4. Check indoor P.C. board. 5. Check indoor EEPROM. (including socket insertion) : Phenomenon of automatic address repetition occurred.
—	—	E01*2	—	No communication with indoor master unit • Disconnection of inter-unit cable between remote controller and master indoor unit (Detected at remote controller side)	Stop (Automatic restart) * When there is center, operation continues.	Displayed when error is detected	Signal receiving of remote controller is defective. 1. Check remote controller inter-unit cables. 2. Check remote controller. 3. Check indoor power cables. 4. Check indoor P.C. board.
—	—	E02	—	Signal sending error to indoor unit (Detected at remote controller side)	Stop (Automatic restart) * When there is center, operation continues.	Displayed when error is detected	Signal sending of remote controller is defective. 1. Check sending circuit inside of remote controller. : Replace remote controller.
—	—	E09	—	Multiple master remote controllers are recognized. (Detected at remote controller side)	Stop (Sub unit continues operation.)	Displayed when error is detected	1. Check there are multiple master units for 2 remote controllers (including wireless). : Master unit is one and others are sub units.
—	—	L20 Central remote controller 98	—	Duplicated indoor central addresses on communication of central control system (AI-NET) (Detected by central controller side)	Stop (Automatic restart)	Displayed when error is detected	1. Check address setup of central control system network. (Network adapter SW01) 2. Check network adapter P.C. board.
—	—	— *3 Central remote controller 99	—	Multiple network adapters on remote controller communication line (Detected by central controller side)	Operation continues.	Displayed when error is detected	1. Check multiple network adapters. 2. Check inter-unit cable/miscabling of remote controller. : Only one network adapter on remote controller communication line
—	—	— *3 Central remote controller 97	—	Interruption of central control system (AI-NET) communication circuit (Detected by central controller side)	Operation continues. (According to handy remote controller)	Displayed when error is detected	1. Check communication line/miscabling. Check power of indoor unit. 2. Check communication. (XY terminals) 3. Check network adapter P.C. board. 4. Check central controller (such as central control remote controller, etc.).
—	—	— Central remote controller b7	—	Indoor Gr sub unit error (Detected by central controller side)	Continuation/stop (Based on a case)	Displayed when error is detected	Check the check code of corresponding unit by handy remote controller.

*2 Check code is not displayed by wired remote controller. (Usual operation of air conditioner is disabled.)

For wireless type models, E01 is notified by the display lamp.

*3 These errors are related to communication of remote controllers (A, B) and central system (AI-NET, X, Y), and [E01], [E02], [E03], [E09], or [E18] is displayed or no check code is displayed on the remote controller according to the error contents.

10-3. Error Mode Detected by LED on Outdoor P.C. Board

<SW800: LED display in bit 1, bit 2, bit 3 OFF>

- When multiple errors are detected, the latest error is displayed.
- When LED display is (Go on), there is the main cause of trouble on the objective part of control at CDB side and the unit stops.
- When LED display is (Flash), there is the main cause of trouble on the objective part of control at IPDU side and the unit stops.
- When case thermostat operates, the communication is interrupted on the serial circuit. If continuing the case thermostat operation, a serial communication error occurs because serial sending to the indoor unit is interrupted.

	No.	Item	Check code		LED display			
			Type A	Type B	D800 (Red)	D801 (Yellow)	D802 (Yellow)	D803 (Yellow)
CDB side	1	TE sensor error	F06	18				
	2	TD sensor error	F04	19				
	3	TS sensor error	F06	18				
	4	TO sensor error	F08	1B				
	5	Discharge temp. error	P03	1E				
	6	DC outdoor fan error	P22	1A				
	7	Communication error between IPDU (Abnormal stop)	L29	1C				
	8	High-pressure release operation	P04	21				
				—				
	9	EEPROM error	—	—				
10	Communication error between IPDU (No abnormal stop)	—	—					
IPDU side	11	G-Tr short-circuit protection	P26	14				
	12	Detection circuit error	P29	16				
	13	Current sensor error	H03	17				
	14	Phase missing detection	H03	17				
	15	Comp. lock error	H02	1D				
	16	Comp. breakdown	H01	1F				

: Go on : Go off : Flash (5Hz)

<<Check code>>

The check codes are classified into Type A and Type B according to the used remote controller. Be sure to check the remote controller which you use.

Type A :

Neutral 2-cores type wired remote controller such as RBC-AMT21E, RBC-AS21E, and wireless remote controller kit such as TCB-AX21U (W)-E

Type B :

Polarized 3-cores type wired remote controller such as RBC-SR1-PE, RBC-SR2-PE, and central control remote controller such as RBC-CR64-PE

10-4. Troubleshooting Procedure for Each Check Code

10-4-1. New Check Code/Present Check Code (Central Control Side)

[E01 error]/*[99 error]

* : When central controller [99] is displayed, there are other causes of error.

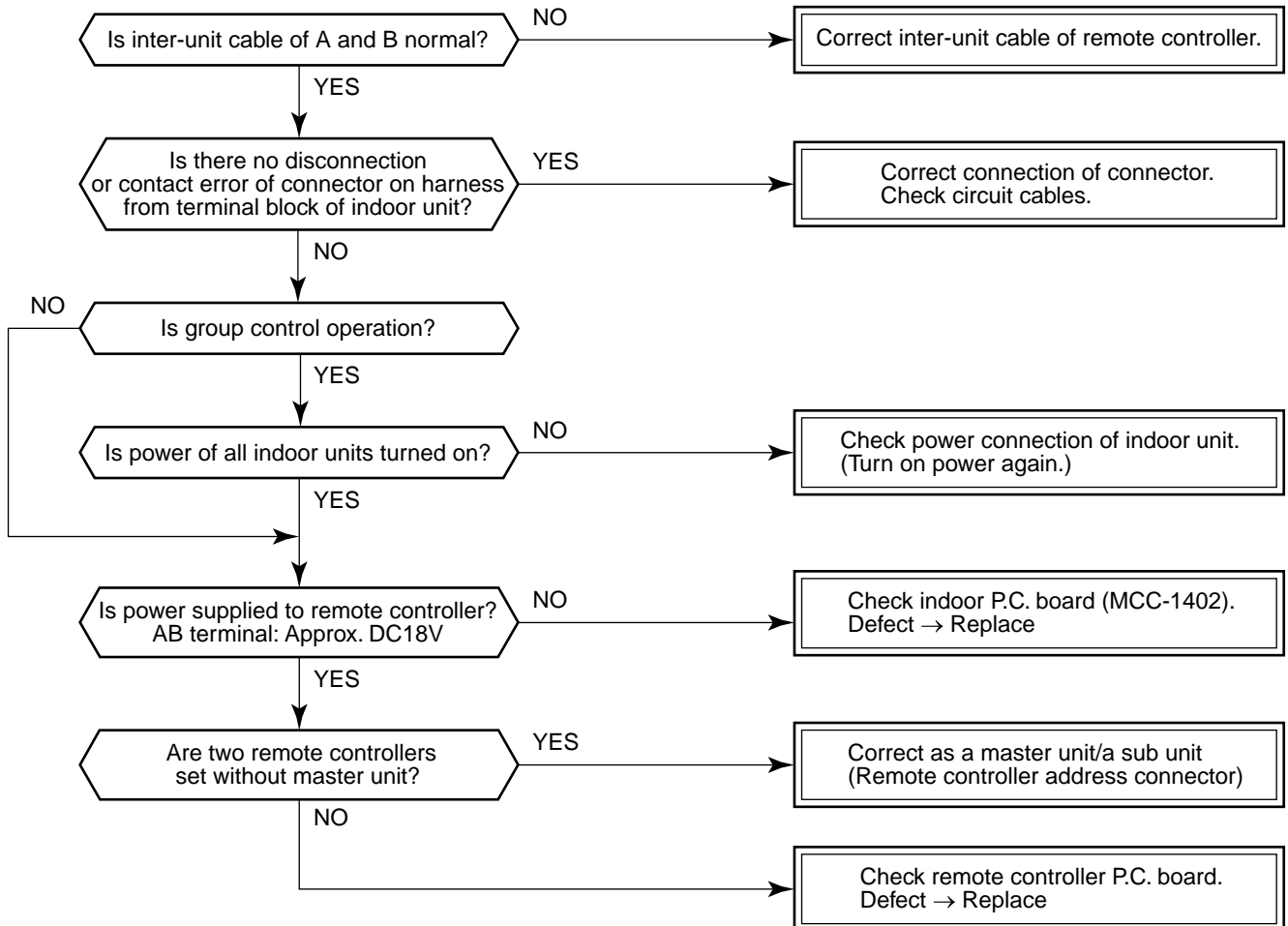

[E09 error]/*[99 error]

* : When central controller [99] is displayed, there are other causes of error.

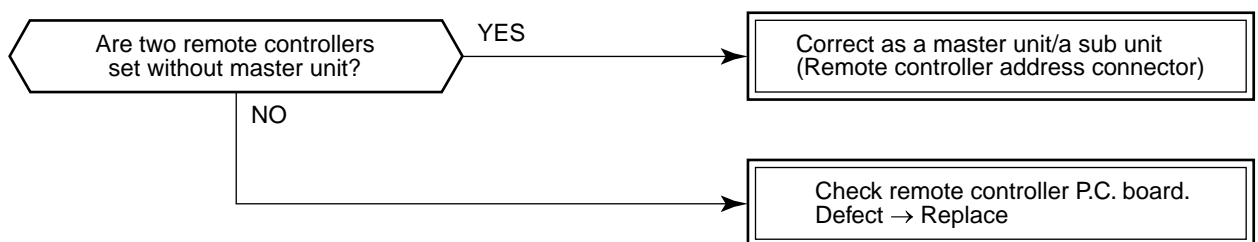

[E04 error]/[04 error]

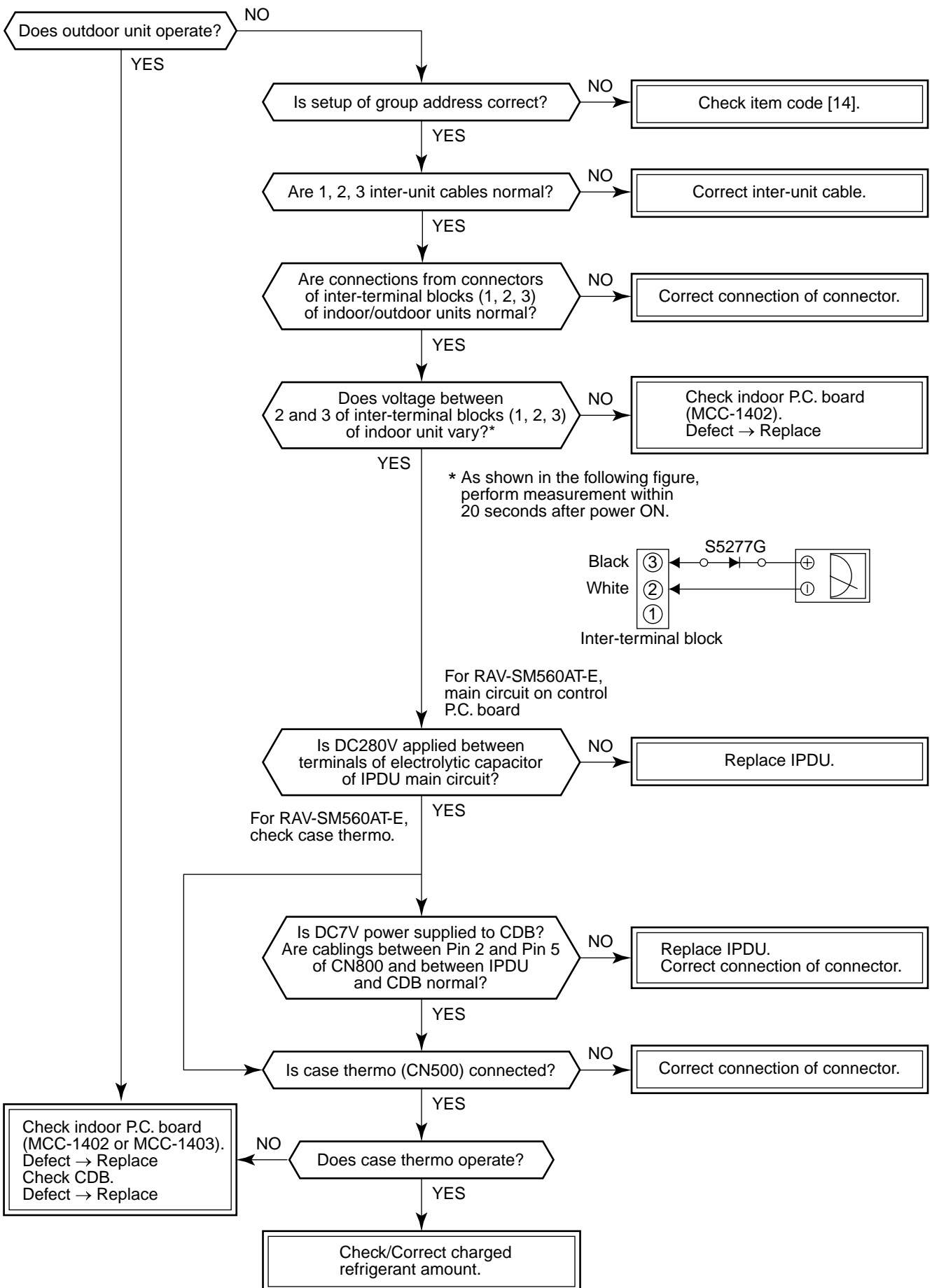

[E10 error]/[CF error]

<Only for 4-way air discharge cassette type (RAV-SM560UT-E/RAV-SM800UT-E)>

Check indoor control P.C. board (MCC-1402).
Defect → Replace

[E18 error]/[97 error] *[99 error]

* : When central controller [99] is displayed, there are other causes of trouble.

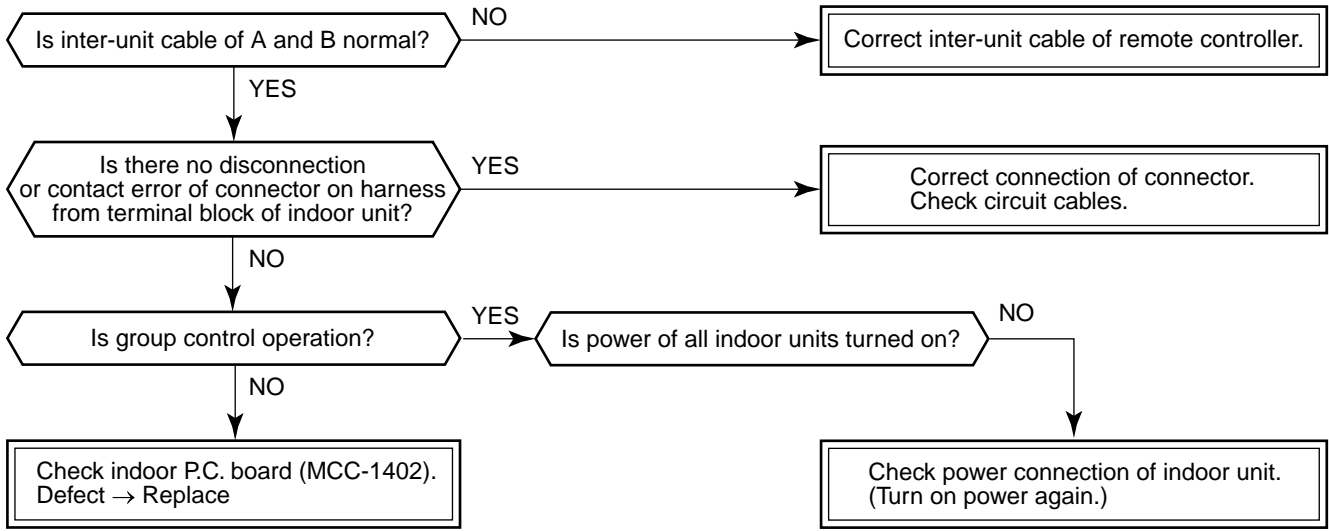

[E08, L03, L07, L08 error]/ *[96 error] [99 error]

* : When central controller [99] is displayed, there are other causes of trouble.

E08 : Duplicated indoor unit numbers

L03 : Two or more master units in a group control

L07 : One or more group addresses of [Individual] in a group control

L08 : Unset indoor group address (99)

If the above is detected when power has been turned on, the mode automatically enters in automatic address setup mode. (Check code is not displayed.)

However, if the above is detected during automatic address setup mode, the check code may be displayed.

[L09 error]/[46 error]

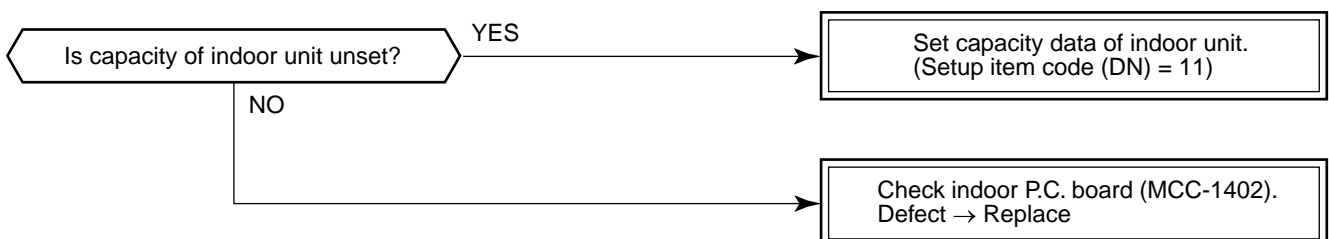

[L20 error]/[98 error]

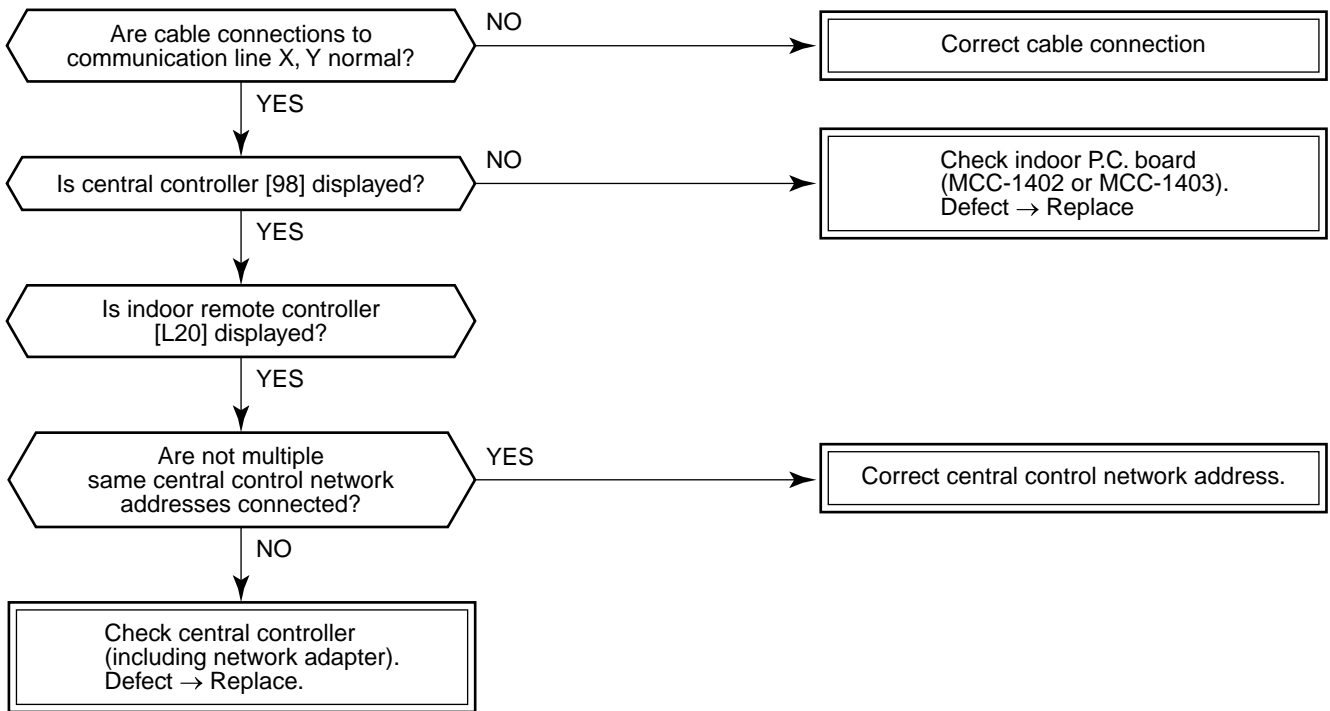

[L30 error]/[B6 error]

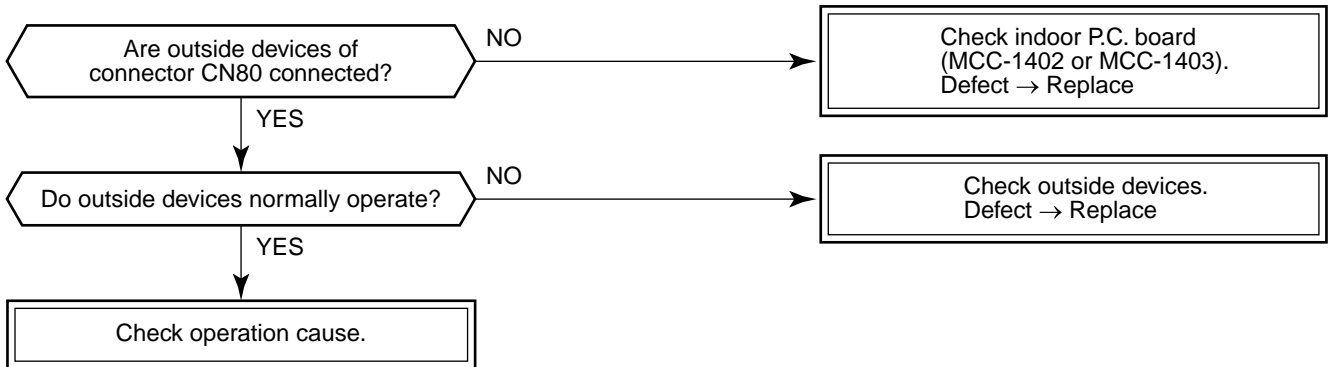

[b7 error] (Central controller)

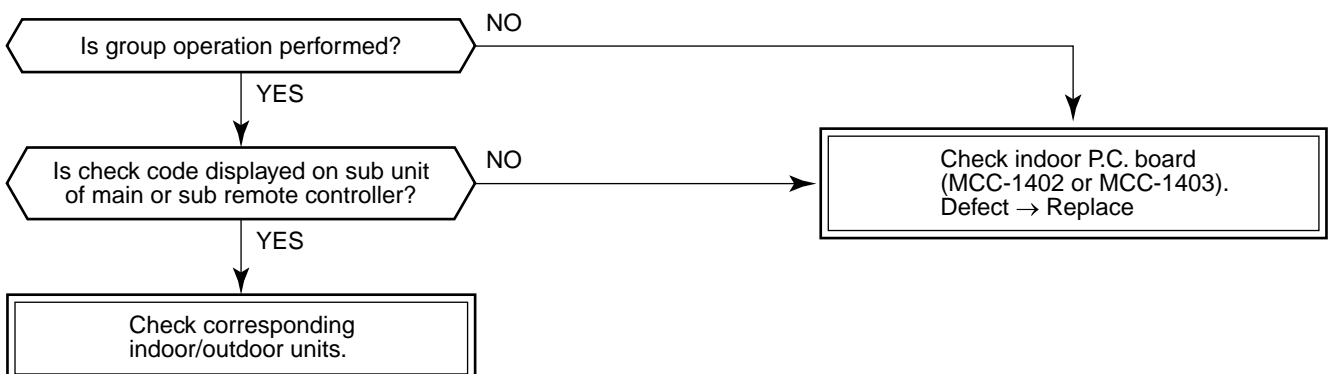

[P10 error]/[Ob error]

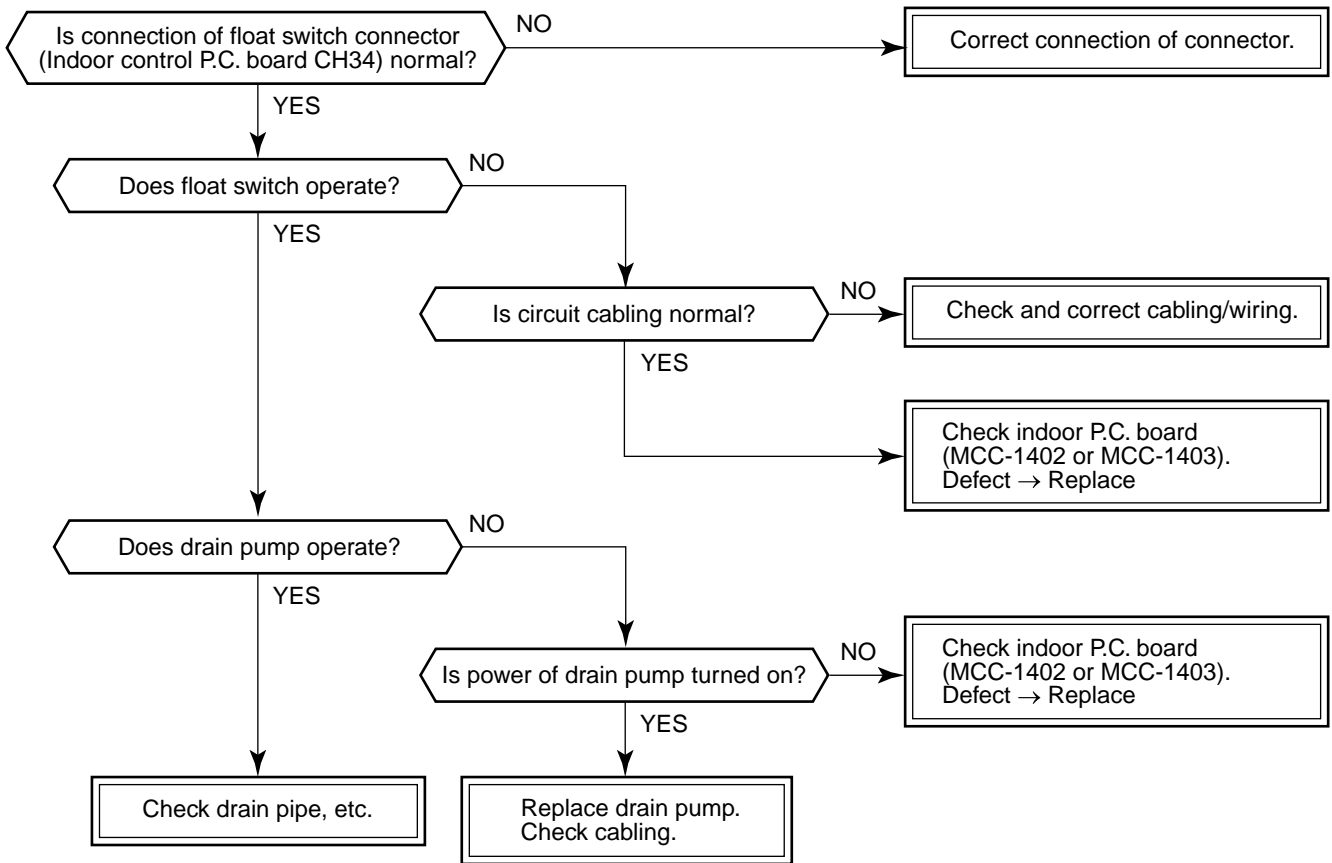

[F10 error] [0C error]



[P12 error]/[11 error]

<Only for 4-way air discharge cassette type models (RAV-SM560UT-E/RAV-SM800UT-E)>

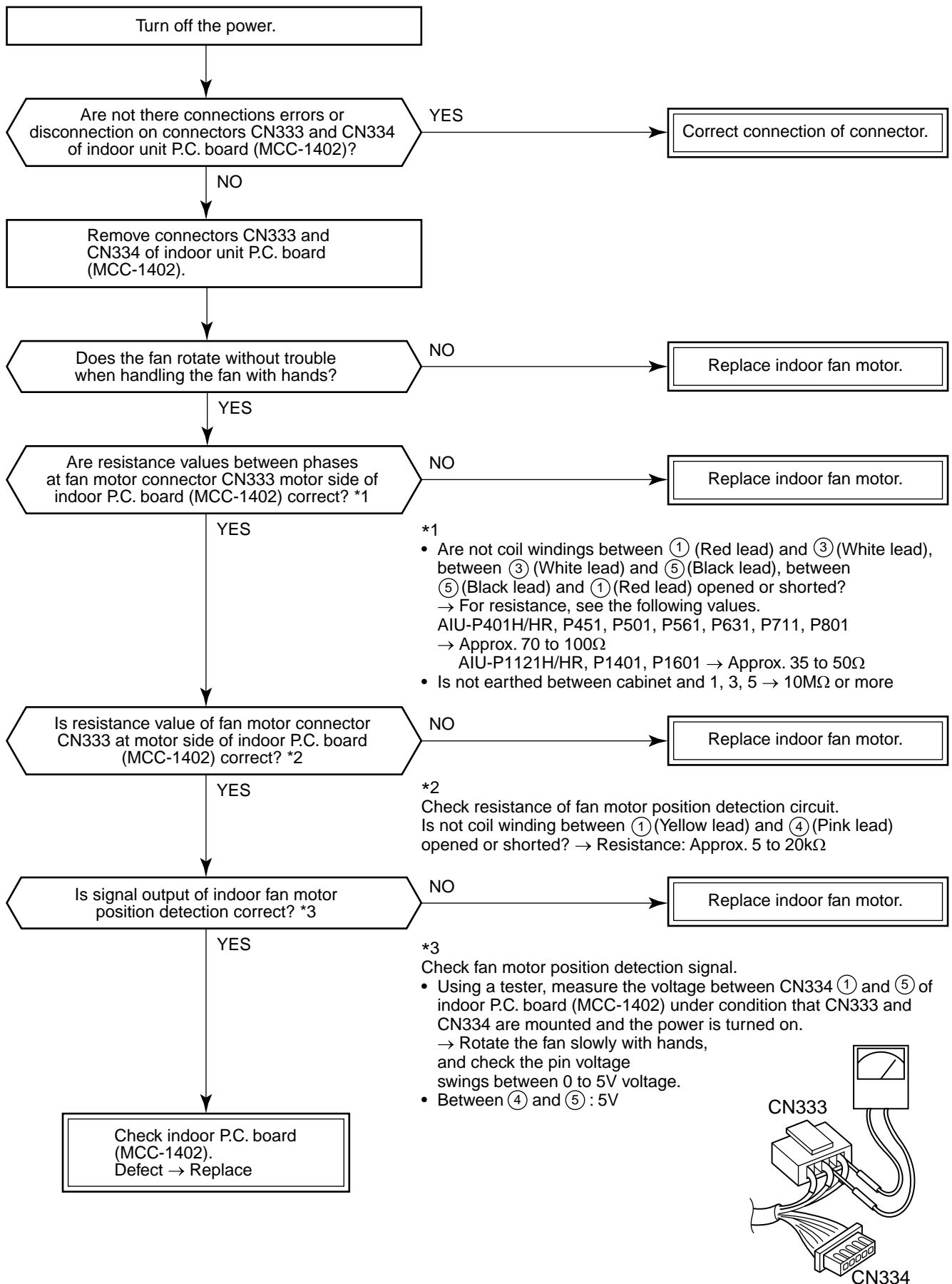

**[P22 error]/[1A error]
(RAV-SM800AT-E)**

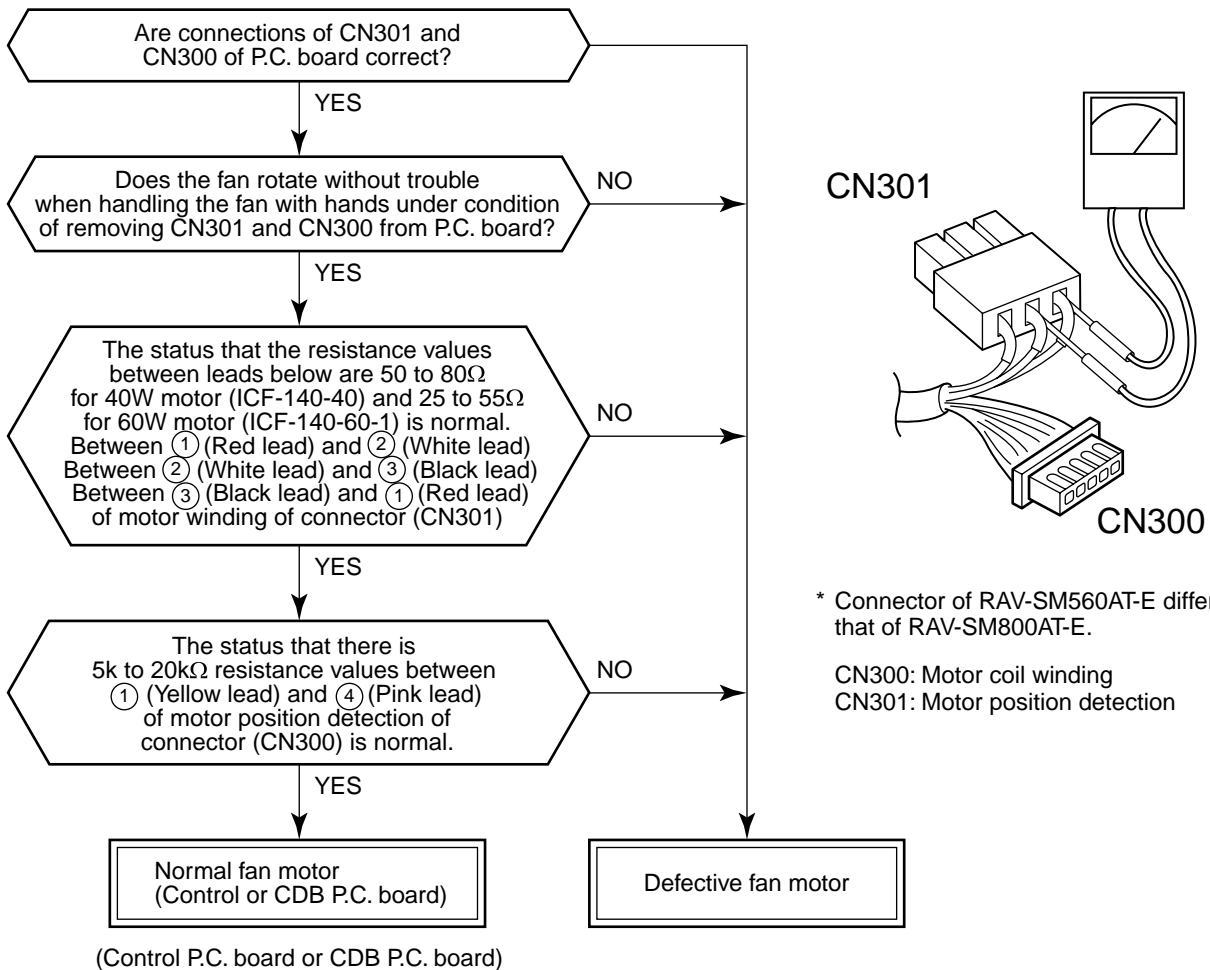

NOTE :

However, GND circuit error inside of the motor is rarely detected even if the above check is carried out. When the circuit does not become normal even if P.C. board has been replaced, replace outdoor fan motor.

	Single phase	Single phase
	RAV-SM560AT-E	RAV-SM800AT-E
Objective P.C. board	Control P.C. board	CDB P.C. board
Fan motor winding	CN300	CN301
Motor position detection	CN301	CN300
Fan motor winding		
Motor position detection		

[P19 error]/[08 error]

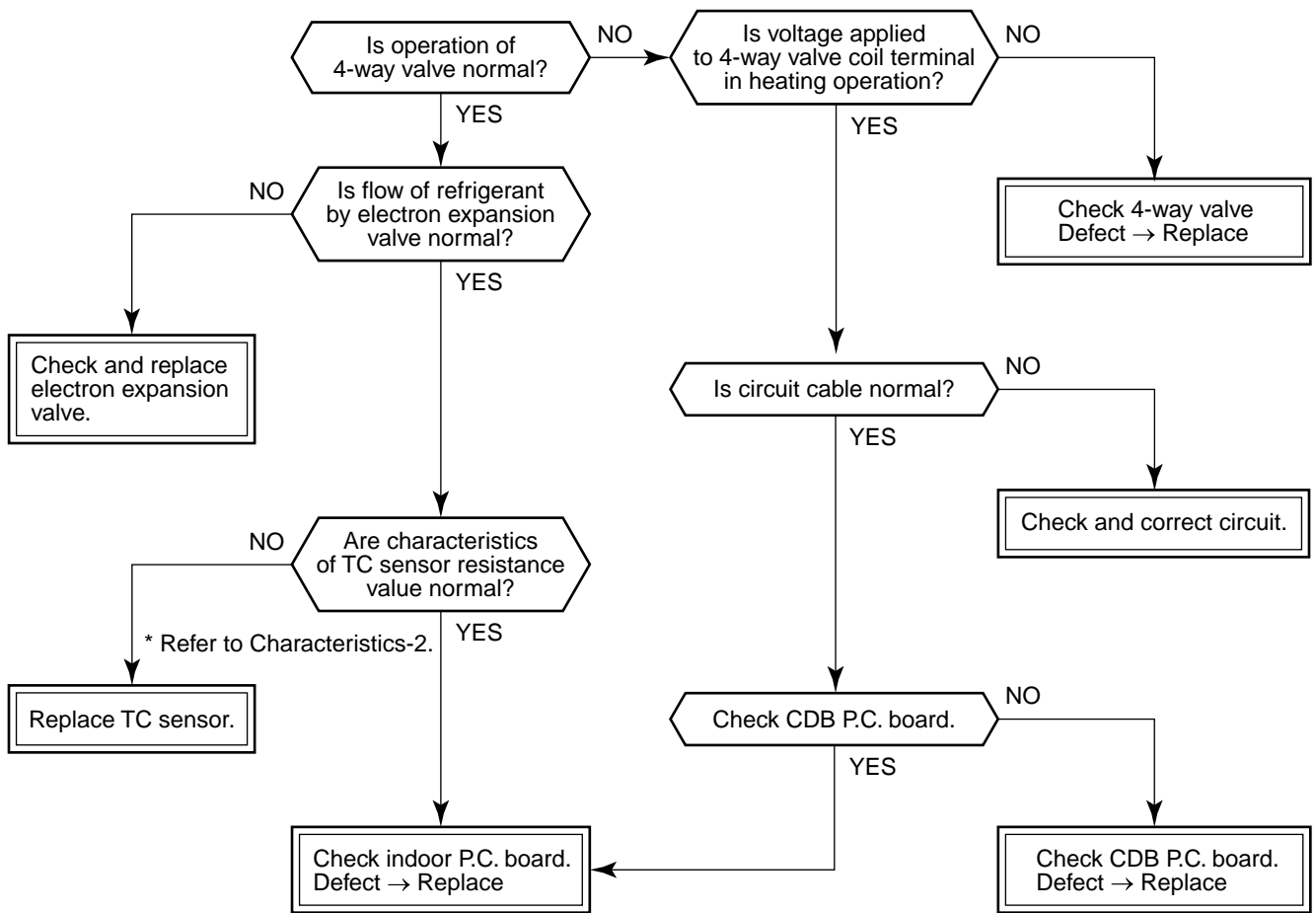

* For RAV-SM560AT-E, check control P.C. board.

- In cooling operation, if high pressure is abnormally raised, [P19 error]/[08 error] may be displayed. In this case, remove cause of pressure up and then check again referring to the item [P04 error]/[21 error].

[F02 error]/[0d error]

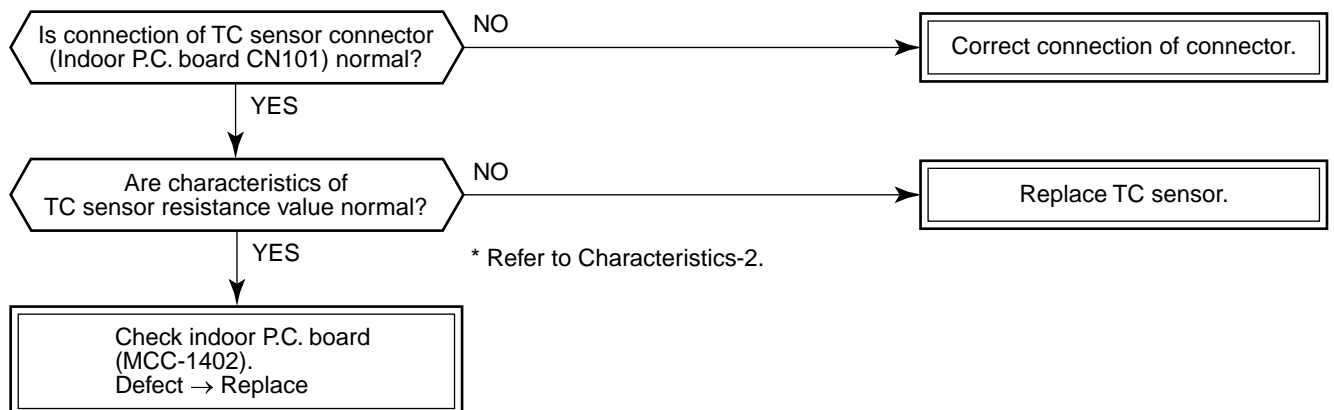

[F01 error]/[0F error]

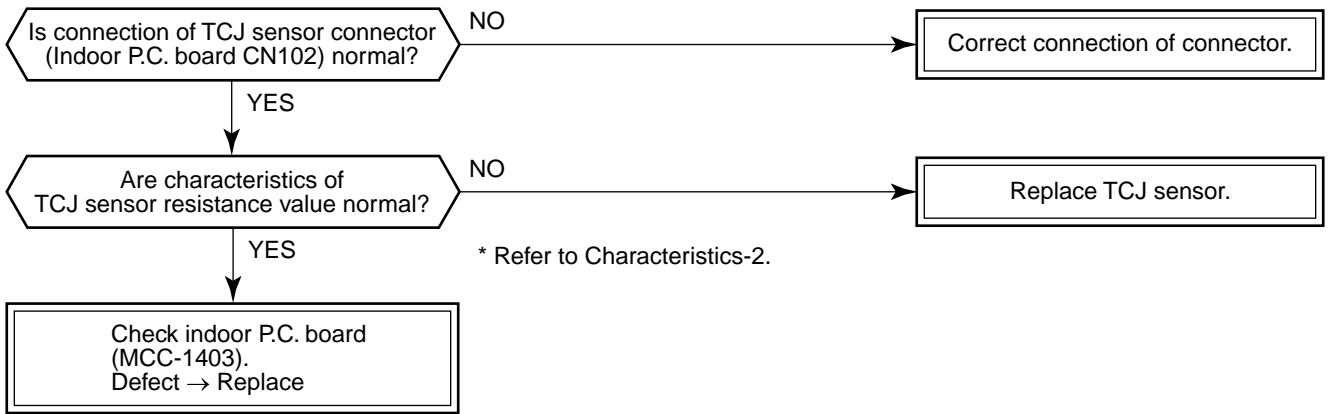

[P26 error]/[14 error]

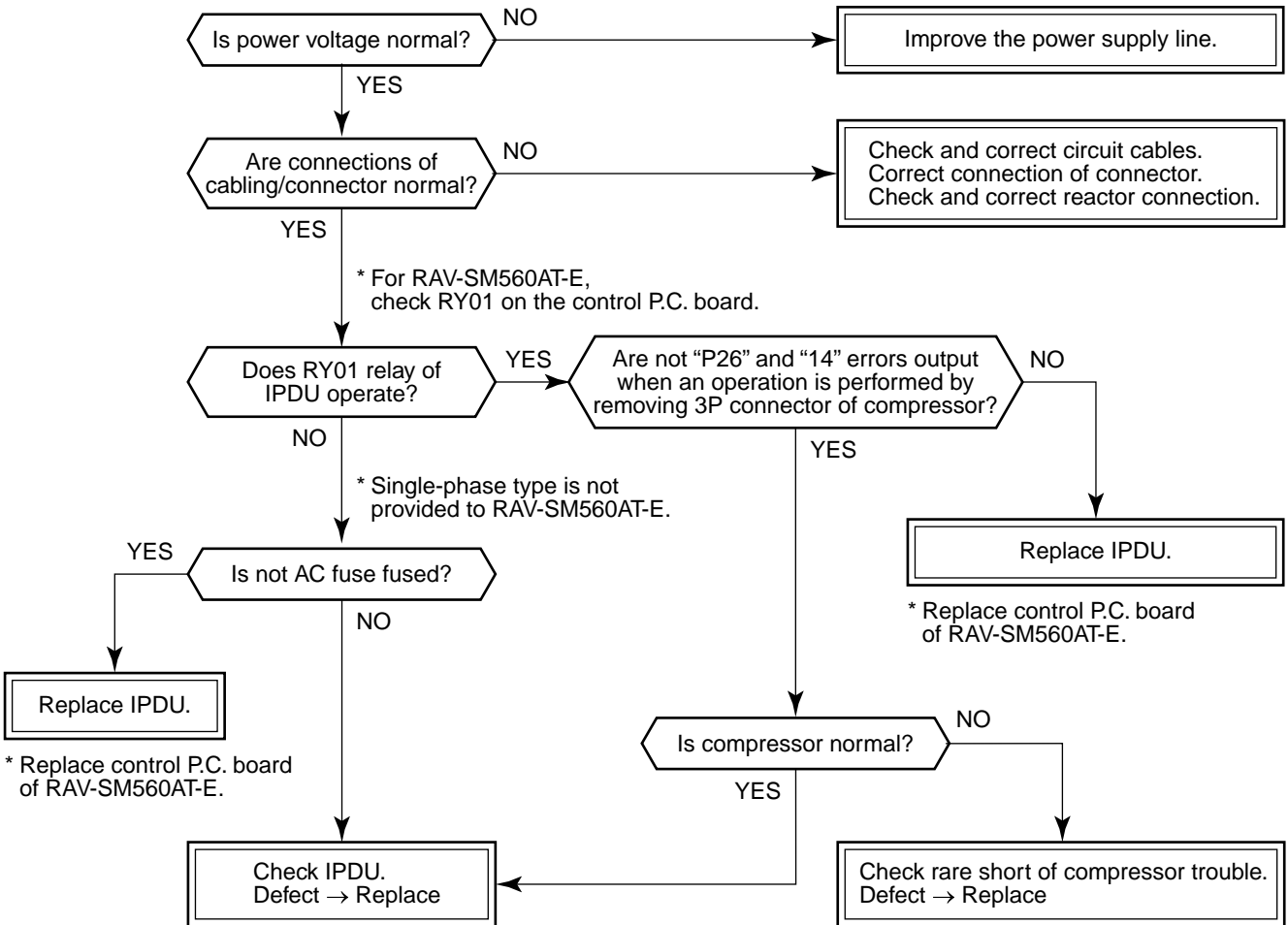

[P29 error]/[16 error]

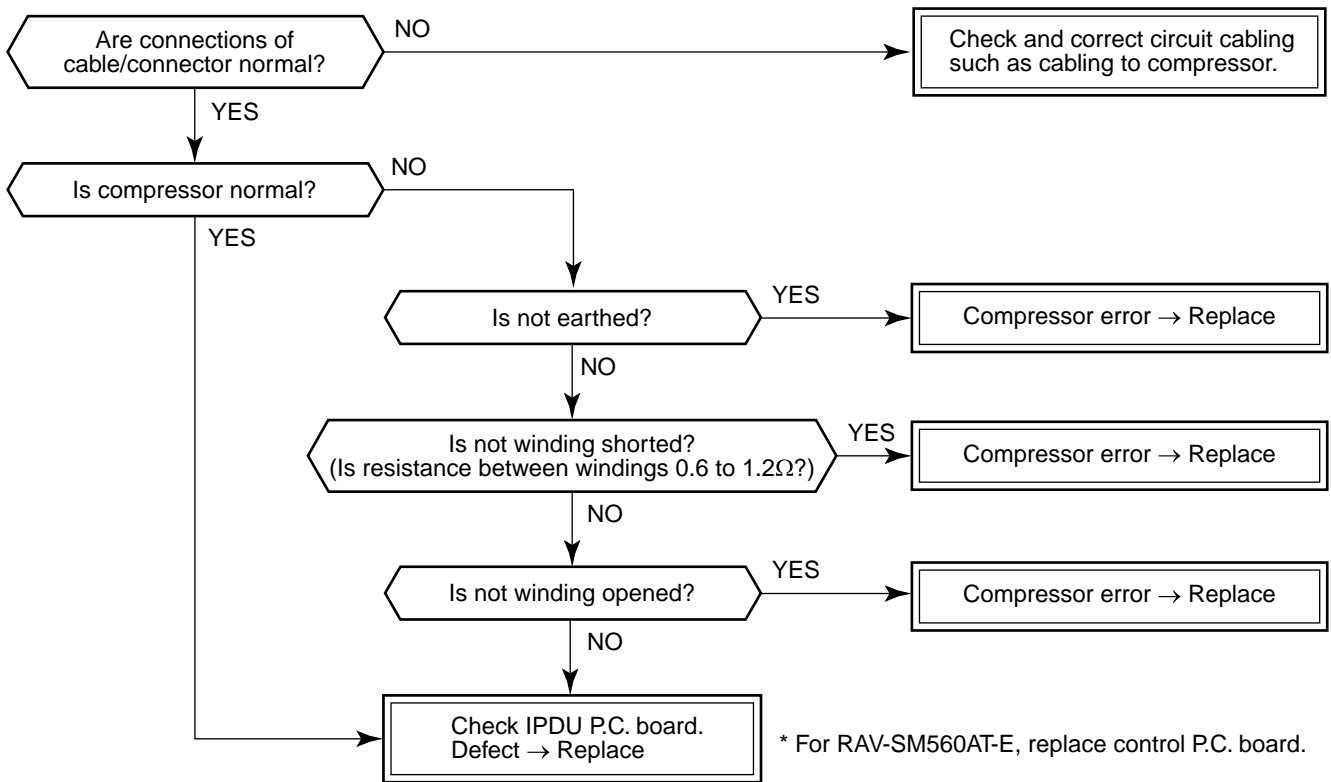

[H03 error]/[17 error]

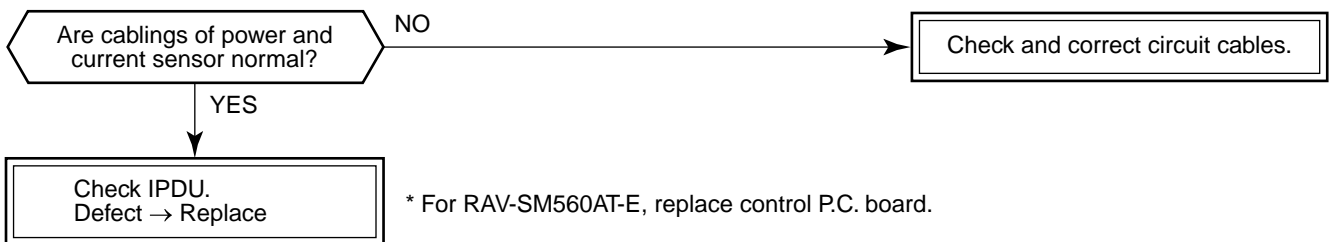

[F06 error]/[18 error]

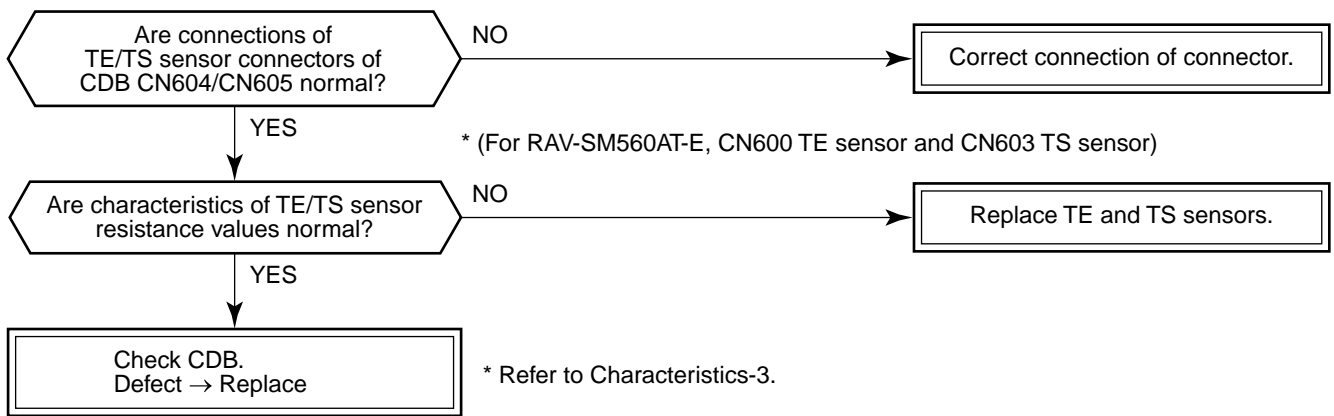

[F04 error]/[19 error]

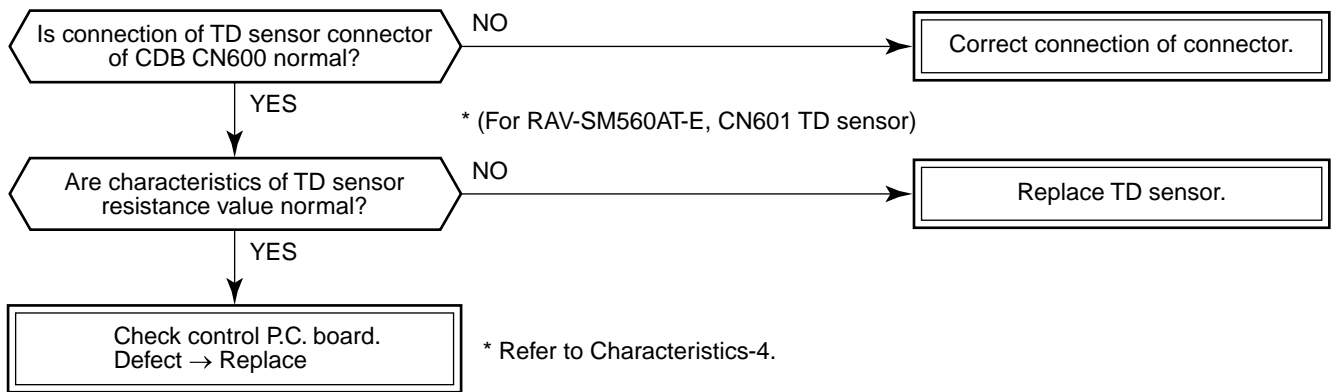

[F08 error]/[1b error]

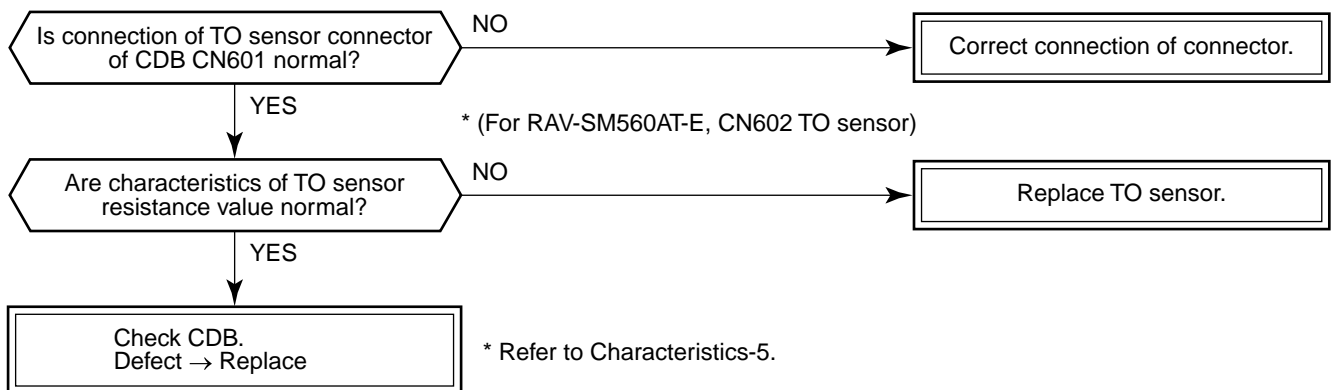

[L29 error]/[1C error]

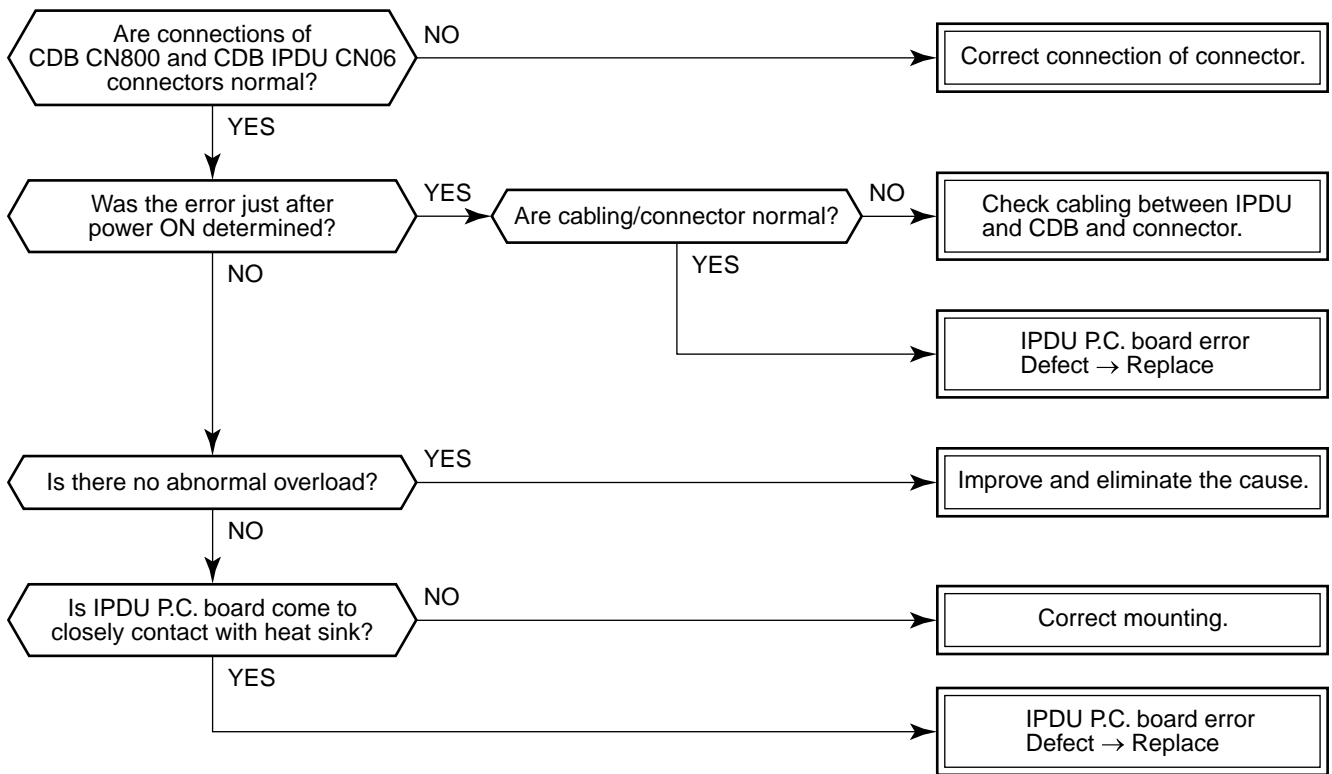

[H02 error]/[1d error]

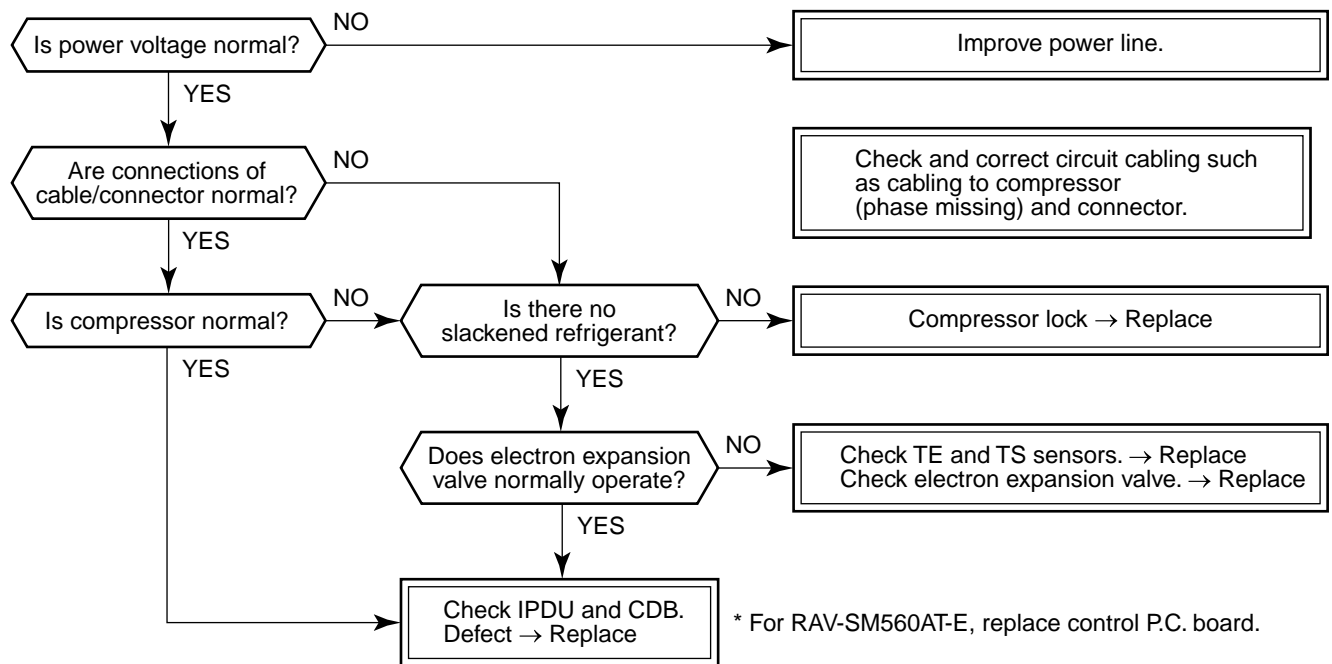

[P03 error]/[1E error]

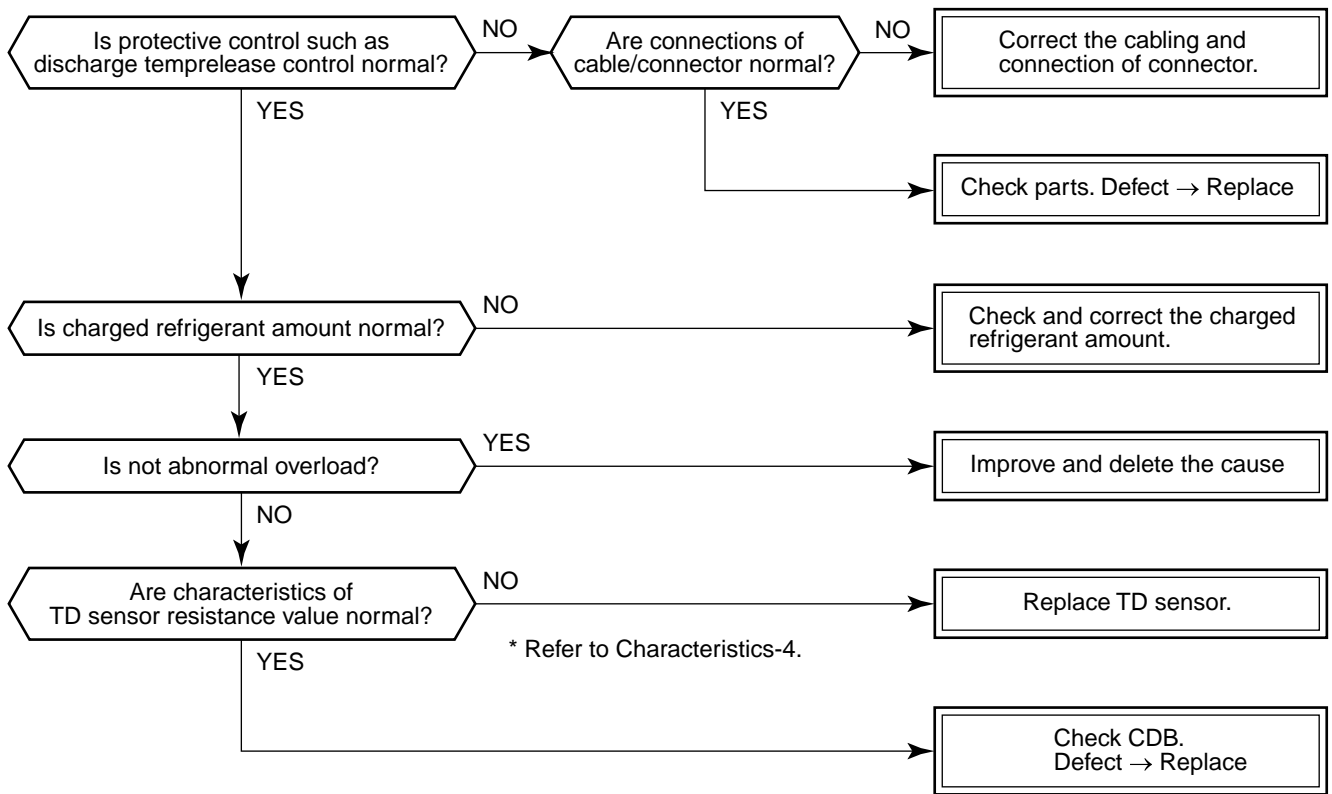

* For RAV-SM560AT-E, replace control P.C. board.

[H01 error]/[1F error]

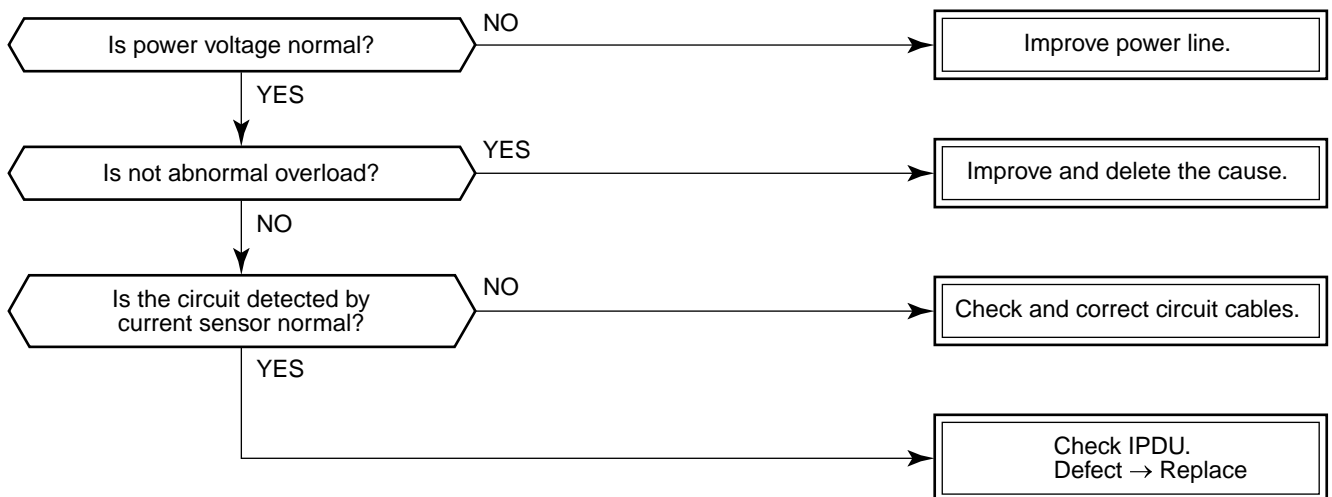

* For RAV-SM560AT-E, replace control P.C. board.

[P04 error]/[21 error]

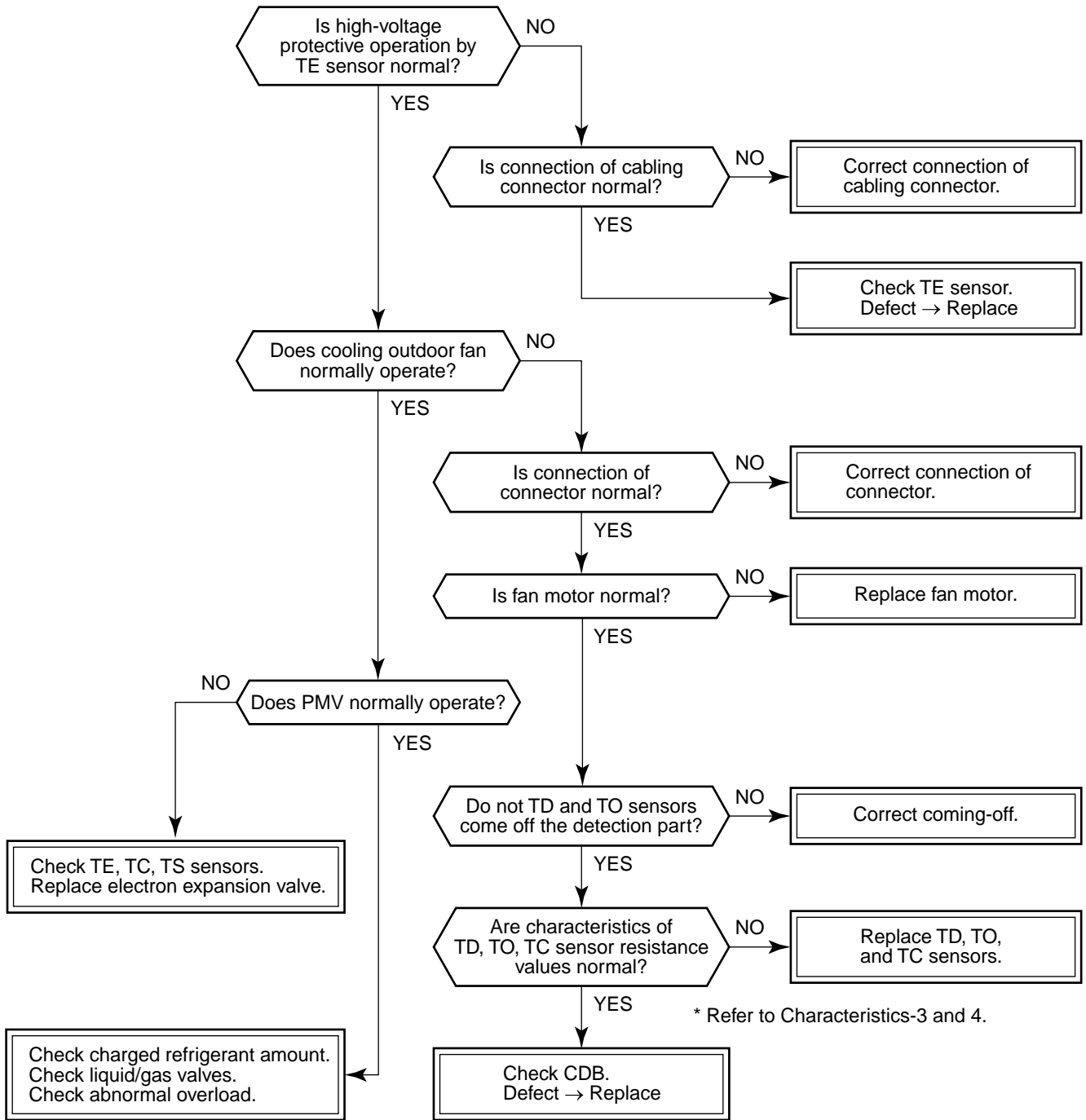

* Refer to Characteristics-3 and 4.

* For RAV-SM560AT-E, replace control P.C. board.

[97 error] (Central controller)

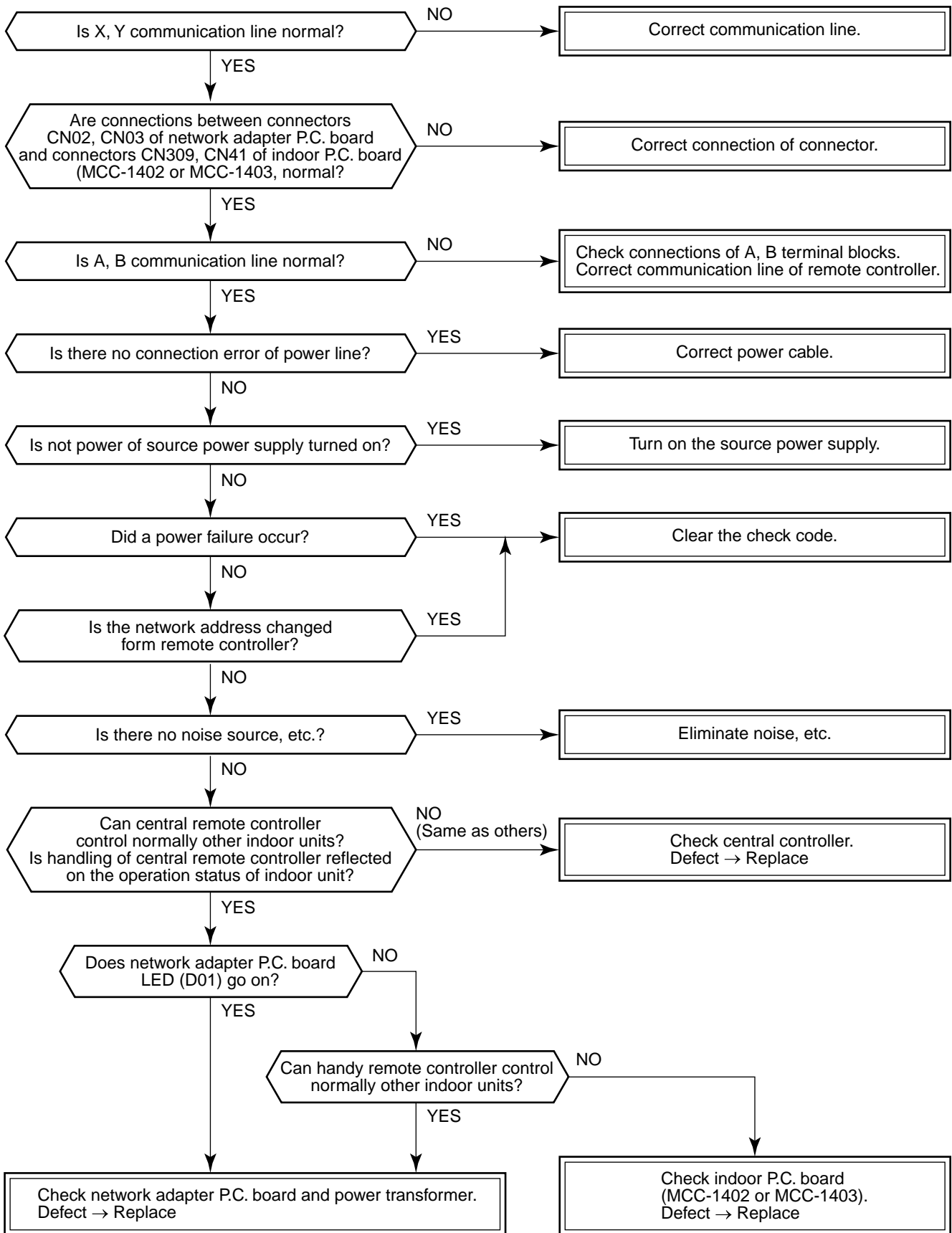

[E03 error] (Master indoor unit)

[E03 error] is detected when the indoor unit cannot receive a signal sent from the main remote controller (and central controller).

In this case, check the communication cables of the remote controllers A and B, the central control system X and Y. As communication is disabled, [E03] is not displayed on the main remote controller and the central controller. [E01] is displayed on the main remote controller and [97 error] on the central controller, respectively. If [E03] occurs during an operation, the air conditioner stops.

[F29 error] / [12 error]

[F29 error] or [12 error] indicates detection of trouble which occurred on IC10 non-volatile memory (EEPROM) on the indoor unit P.C. board during operation of the air conditioner. Replace the service P.C. board.

* If EEPROM has not been inserted when the power was turned on or if EEPROM data never be read/written, the automatic address mode is repeated. In this time, the central controller displays [97 error].

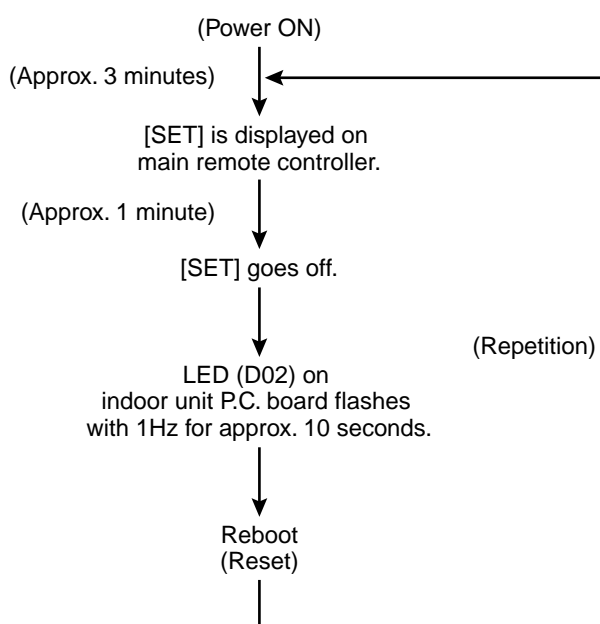

[P31 error] (Sub indoor unit)

When the master unit of a group operation has detected [E03], [L03], [L07], or [L08] error, the sub unit of the group operation detects [P31 error] and then it stops. There is no display of the check code or alarm history of the main remote controller.

(In this model, the mode enters in automatic address set mode when the master unit has detected [E03], [L03], [L07], or [L08] error.)

10-4-2. Relational Graph of Temperature Sensor Resistance Value and Temperature

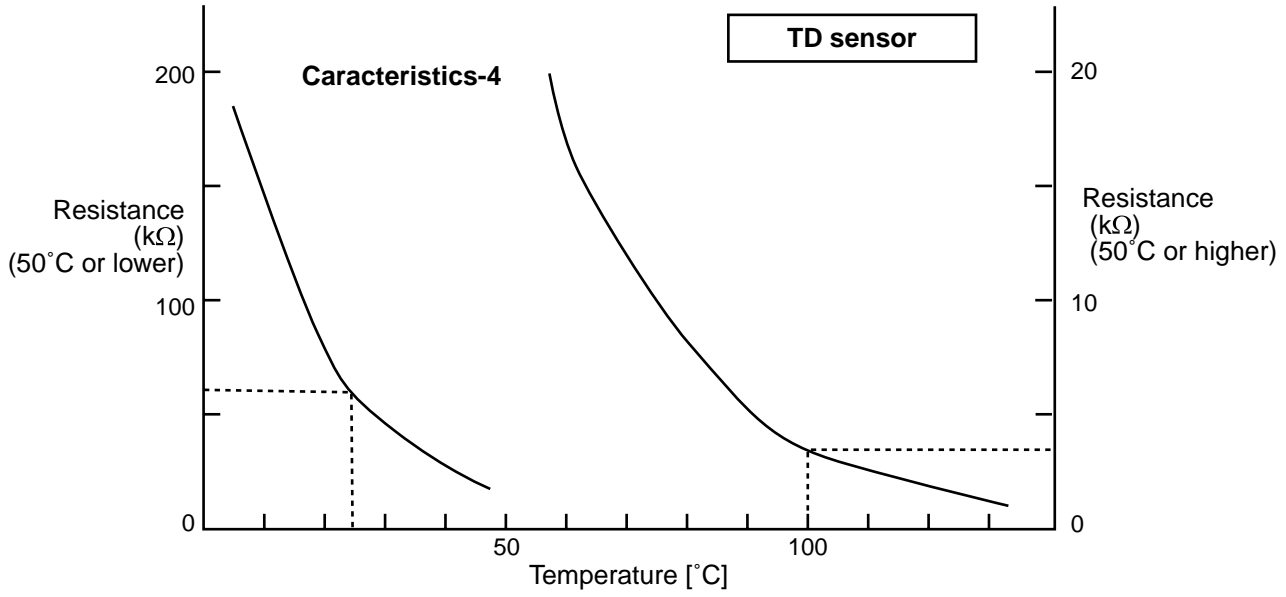
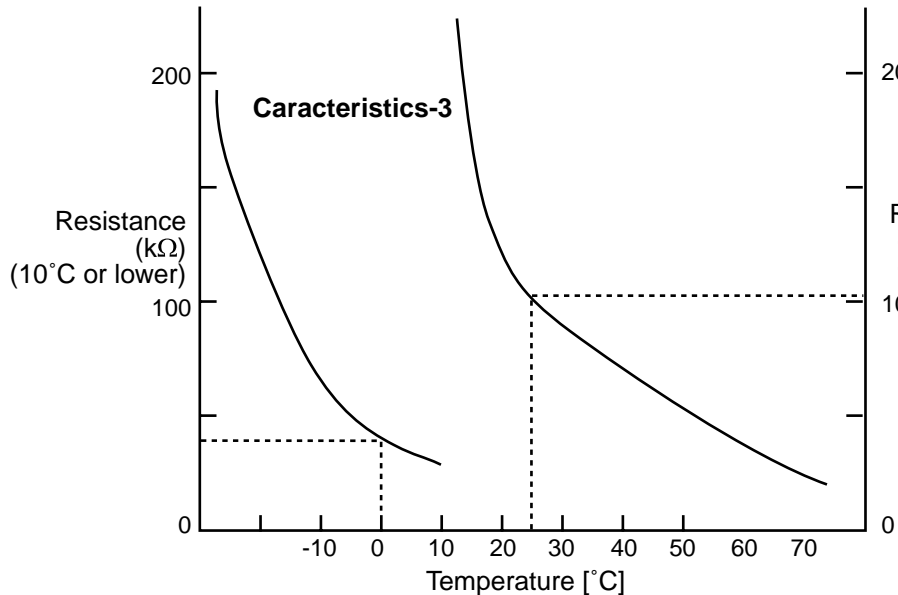
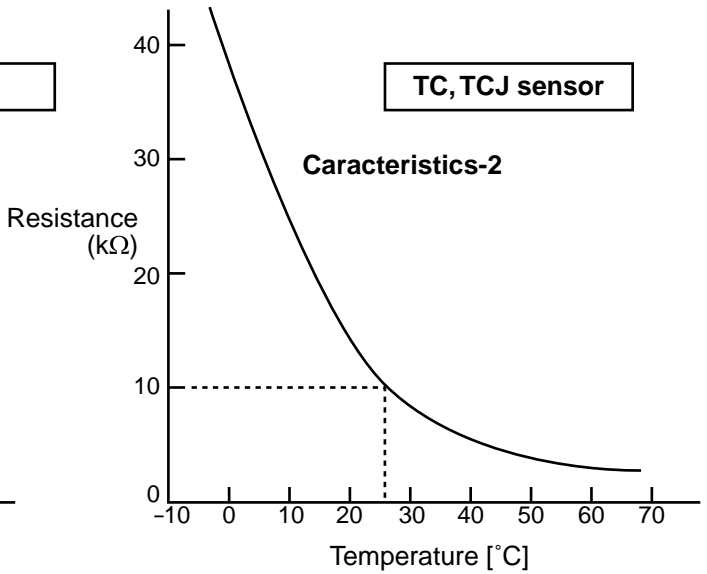
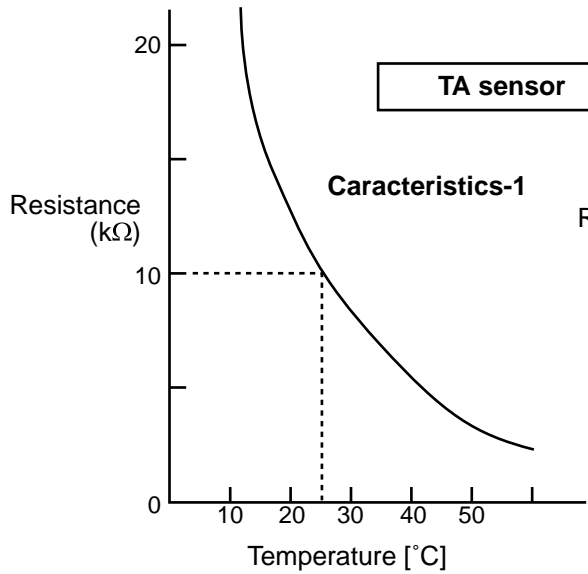

11. REPLACEMENT OF SERVICE INDOOR P.C. BOARD

[Requirement when replacing the service indoor P.C. board assembly]

In the non-volatile memory (Hereinafter said EEPROM, IC10) installed on the indoor P.C. board before replacement, the type and capacity code exclusive to the corresponding model have been stored at shipment from the factory and the important setup data such as system/indoor/group address set in (AUTO/MANUAL) mode or setting of high ceiling selection have been stored at installation time. Replace the service indoor P.C. board assembly according to the following procedure.

After replacement, check the indoor unit address and also the cycle by a test run.

<REPLACEMENT PROCEDURE>

CASE 1

Before replacement, power of the indoor unit can be turned on and the setup data can be readout from the wired remote controller.

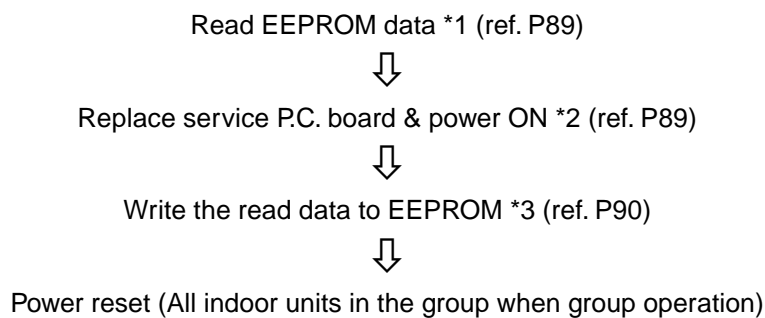

CASE 2

Before replacement the setup data can not be readout from the wired remote controller.

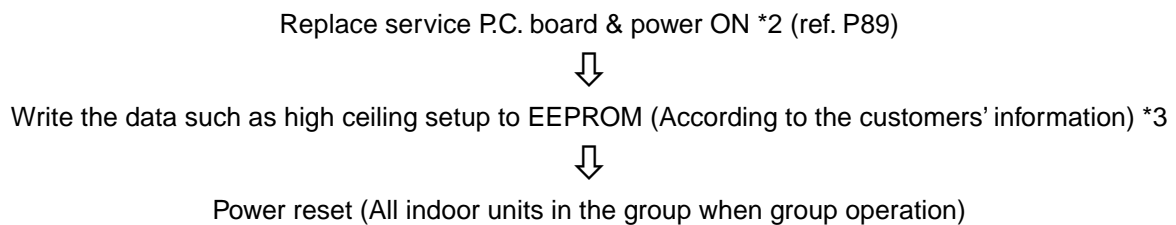

□1 Readout of the setup data from EEPROM

(Data in EEPROM contents, which have been changed at the local site, are read out together with data in EEPROM set at shipment from the factory.)

1. Push **SET**, **CL**, and **ON** buttons of the remote controller at the same time for 4 seconds or more. **1**
(Corresponded with No. in Remote controller)
When group operation, the master indoor unit address is displayed at the first time. In this time, the item code (DN) **10** is displayed. The fan of the selected indoor unit operates and the flap starts swinging if any.
2. Every pushing **UNIT** button, the indoor unit address in the group are displayed successively. **2** Specify the indoor unit No. to be replaced.
3. Using the set temperature **▲** / **▼** buttons, the item code (DN) can be moved up and down one by one. **3**
4. First change the item code (DN) from **10** to **01**. (Setting of filter sign lighting time) Make a note of the set data displayed in this time.
5. Next change the item code (DN) using the set temperature **▲** / **▼** buttons. Also make a note of the set data.
6. Repeat item 5. and make a note of the important set data as shown in the later table (Ex.).
• **01** to **9F** are provided in the item code (DN). On the way of operation, DN No. may come out.
7. After finishing making a note, push **ON** button to return the status to usual stop status. **6**
(Approx. 1 minute is required to start handling of the remote controller.)

Minimum requirements for item code

DN	Contents
10	Type
11	Indoor unit capacity
12	Line address
13	Indoor address
14	Group address

- (1) Type and capacity of the indoor unit is necessary to set the revolutions frequency of the fan.
- (2) If Line/Indoor/Group addresses differ from those before replacement, the mode enters in automatic address setup mode and a manual resetting may be required.

□2 Replacement of service P.C. board

1. Replace the P.C. board with a service P.C. board.
In this time, setting of jumper line (cut) or setting of (short-circuit) connecting connectors on the former P.C. board should be reflected on the service P.C. board.
 2. According to the system configuration, turn on power of the indoor unit with any method in the following items.
 - a) In case of single (individual) operation
Turn on the power supply.
 - 1) Wait for completion of automatic address setup mode (Required time: Approx. 5 minutes) and then proceed to **□3**.
(Line address = 1, Indoor address = 1, Group address = 0 (Individual) are automatically set.)
 - 2) Push **SET**, **CL**, and **ON** buttons of the remote controller at the same time for 4 seconds or more (**1** operation), interrupt the automatic address setup mode, and then proceed to **□3**.
(Unit No. **ALL** is displayed.)
 - b) In case of group operation
Turn on power of the indoor unit of which P.C. board has been replaced with the service P.C. board with any method in the following items.
 - 1) Turn on power of the replaced indoor unit only.
(However, the remote controller is also connected. Otherwise **□3** operation cannot be performed.)
Same as 1) and 2) in item a).
 - 2) Turn on power of the multiple indoor units including replaced indoor unit.
 - Only 1 system for twin, triple, double twin
 - For all units in the group
- Wait for completion of automatic address setup mode (Required time: Approx. 5 minutes) and then proceed to **□3**.

* The master unit of a group may change by setup of automatic address. The line address/indoor address of the replaced indoor unit are automatically set to the vacant addresses except addresses belonging to other indoor units which have not been replaced. It is recommended to make a note that the refrigerant line which includes the corresponding indoor unit and that the corresponding indoor unit is master or sub in the group control.

□3 Writing of the setup contents to EEPROM

(The contents of EEPROM installed on the service P.C. board have been set up at shipment from the factory.)

1. Push **SET**, **CL**, and **UNIT** buttons of the remote controller at the same time for 4 seconds or more. **1**
(Corresponded with No. in Remote controller)
In group operation control, the master indoor unit No. is displayed at the first time. (If the automatic address setup mode is interrupted in item 2. - a) - 2) in the previous page, the unit No. *ALL* is displayed.) In this time, the item code (DN) *10* is displayed. The fan of the selected indoor unit operates and the flap starts swinging if any.
2. Every pushing **UNIT** button, the indoor unit numbers in the group control are displayed successively. **2**
Specify the indoor unit No. of which P.C. board has been replaced with a service P.C. board.
(When the unit No. *ALL* is displayed, this operation cannot be performed.)
3. Using the set temperature **▲** / **▼** buttons, the item code (DN) can be moved up and down one by one. **3**
4. First set a type and capacity of the indoor unit.
(Setting the type and capacity writes the data at shipment from the factory in EEPROM.)
 - 1) Set the item code (DN) to *10*. (As it is)
 - 2) Using the timer time **▲** / **▼** buttons, set up a type. **4**
(For example, 4-way air discharge cassette type is 0001) Refer to the attached table.
 - 3) Push **SET** button. (OK when the display goes on.) **5**
 - 4) Using the set temperature **▲** / **▼** buttons, set *11* to the item code (DN).
 - 5) Using the timer time **▲** / **▼** buttons, set the capacity.
(For example, 0012 for class 80) Refer to the attached table.
 - 6) Push **SET** button. (OK when the display goes on.)
 - 7) Push **UNIT** button to return the status to usual stop status. **6**
(Approx. 1 minute is required to start handling of the remote controller.)
5. Next write the contents which have been set up at the local site such as the address setup in EEPROM.
Repeat the above procedure 1. and 2.
6. Using the set temperature **▲** / **▼** buttons, set *01* to the item code (DN).
(Setup of lighting time of filter sign)
7. The contents of the displayed setup data in this time should be agreed with the contents in the previous memorandum in □1.
 - 1) If data disagree, change the displayed setup data to that in the previous memorandum by the timer time **▲** / **▼** buttons, and then push **SET** button. (OK when the display goes on.)
 - 2) There is nothing to do when data agrees.
8. Using the set temperature **▲** / **▼** buttons, change the item code (DN).
As same as the above, check the contents of the setup data and then change them to data contents in the previous memorandum.
9. Then repeat the procedure 7. and 8.
10. After completion of setup, push **UNIT** button to return the status to the usual stop status. **6**
(Approx. 1 minute is required to start handling of the remote controller.)

* *01* to *9F* are provided in the item code (DN).
On the way of operation, DN No. may come out.
When data has been changed by mistake and **SET** button has been pushed, the data can be returned to the data before change by pushing **CL** button if the item code (DN) was not yet changed.

<REMOTE CONTROLLER>

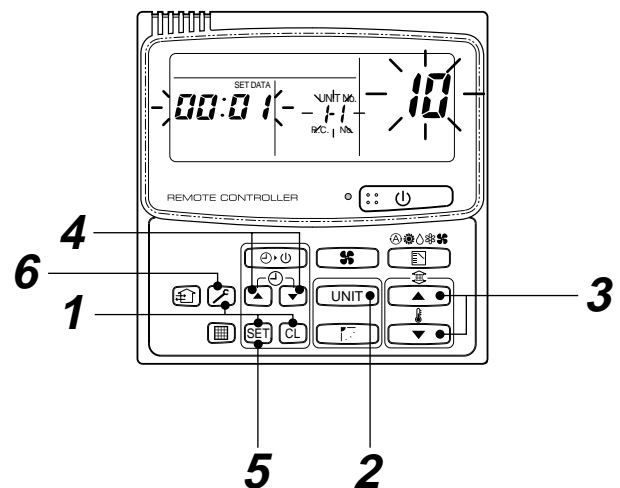

Memorandum for setup contents (Item code table (Example))

DN	Item	Memo	At shipment
01	Filter sign lighting time		According to type
02	Dirty state of filter		0000: Standard
03	Central control address		0099: Unfixed
06	Heating suction temp shift		0002: +2°C (Floor type: 0)
0F	Cooling only		0000: Shared for cooling/heating
10	Type		According to model type
11	Indoor unit capacity		According to capacity type
12	Line address		0099: Unfixed
13	Indoor unit address		0099: Unfixed
14	Group address		0099: Unfixed
19	Flap type (Adjustment of air direction)		According to type
1E	Temp difference of automatic cooling/ heating selecting control points		0003: 3 deg (Ts ± 1.5)
28	Automatic reset of power failure		0000: None
2A	Option		0002:
2b	Thermo output selection (T10 ±B)		0000: Thermo ON
2E	Option		0000:
32	Sensor selection		0000: Body sensor
5d	High ceiling selection		0000: Standard
60	Timer set (Wired remote controller)		0000: Available
8b	Correction of high heat feeling		0000: None

Type

Item code [10]

Setup data	Type	Abbreviated name
0001*	4-way air discharge cassette	RAV-SM560/800TU-E
0004	Concealed duct	RAV-SM560/800BT-E

* Initial setup value of EEPROM installed on the service P.C. board

Indoor unit capacity

Item code [11]

Setup data	Model
0000*	Invalid
0009	56
0012	80



* Initial setup value of EEPROM installed on the service P.C. board

12. SETUP AT LOCAL SITE AND OTHERS



12-1. Indoor Unit

12-1-1. Test Run Setup on Remote Controller

<Wired remote controller>

1. When pushing  button on the remote controller for 4 seconds or more, "TEST" is displayed on LC display. Then push  button.
 - "TEST" is displayed on LC display during operation of Test Run.
 - During Test Run, temperature cannot be adjusted but air volume can be selected.
 - In heating and cooling operation, a command to fix the Test Run frequency is output.
 - Detection of error is performed as usual. However, do not use this function except case of Test Run because it applies load on the unit.
2. Use either heating or cooling operation mode for [TEST].
NOTE : The outdoor unit does not operate after power has been turned on or for approx. 3 minutes after operation has stopped.
3. After a Test Run has finished, push  button again and check that [TEST] on LC display has gone off. (To prevent a continuous test run operation, 60-minutes timer release function is provided to this remote controller.)

<Wireless remote controller> (Option for 4-way air discharge cassette type)

1. Turn off power of the unit.
Remove the adjuster attached with sensors from the ceiling panel. For removing, refer to the Installation manual attached to the ceiling panel. (Be careful to handle the adjuster because cables are connected to the sensor.) Remove the sensor cover from the adjuster. (1 screw)
2. Change ON of Bit [1: TEST] of the sensor P.C. board switch [S003] to OFF.
Mount the sensor cover and mount the adjuster with sensor to the ceiling panel.
Turn on power of the unit.
3. Push  button on the wireless remote controller and select [COOL] or [HEAT] operation mode using  button. (All the display lamps of sensors on the wireless remote controller flash during Test Run.)
 - Do not perform Test Run operation in other modes than [HEAT] / [COOL] mode.
 - Detection of error is performed as usual.
4. After Test Run operation, push  button to stop the operation.
5. Turn off power of the unit.
Return Bit [1] of the sensor P.C. board switch [S003] to the original position. (ON → OFF)
Mount the adjuster with sensors to the ceiling panel.

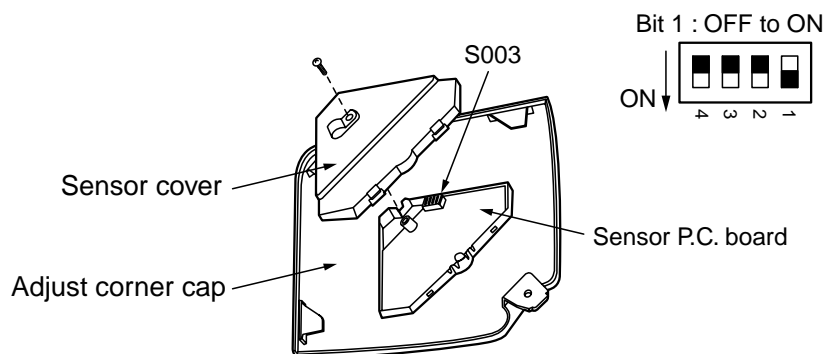

12-1-2. Setup to Select Function

<Procedure> Use this function while the indoor unit stops.

- 1** Push **SET**, **UNIT**, and **STOP** buttons concurrently for 4 seconds or more.
The unit No. displayed at the first time indicates the indoor unit address of the master unit in the group control.
In this time, fan and flap of the selected indoor unit operate.
- 2** Every pushing **UNIT** button, the indoor unit numbers in the group control are displayed successively.
In this time, fan and flap of the selected indoor unit only operate.
- 3** Using the set temperature **▲** / **▼** buttons, set the item code (DN).
- 4** Using the timer time **▲** / **▼** buttons, select the setup data.
- 5** Push **SET** button. (OK if display goes on.)
 - To change the selected indoor unit, proceed to **2**.
 - To change the item to be set, proceed to **3**.
- 6** Pushing **STOP** button returns the status to usual stop status.

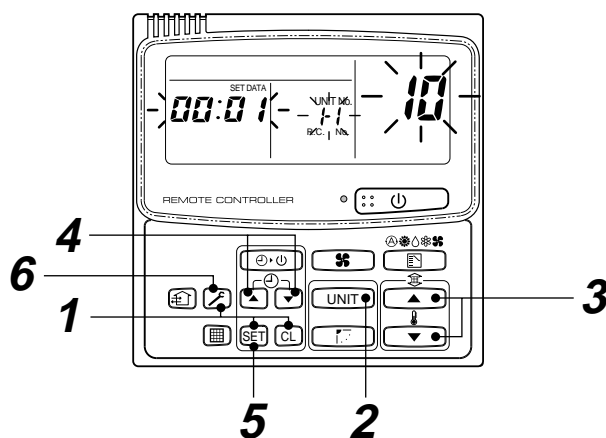

<Operation procedure>

1 → 2 → 3 → 4 → 5 → 6 END

Item No. (DN) table (Selection of function)

DN	Item	Description	At shipment
01	Filter sign lighting time	0000 : None 0002 : 2500H 0004 : 10000H 0001 : 150H 0003 : 5000H 0005 : Clogged sensor used	According to type
02	Dirty state of filter	0000 : Standard 0001 : High degree of dirt (Half of standard time)	0000 : Standard
03	Central control address	0001 : No.1 unit 0099 : Unfixed to 0064 : No.64 unit	0099 : Unfixed
06	Heating suction temp shift	0000 : No shift 0002 : +2°C to 0001 : +1°C 0010 : -10°C (Up to recommendation + 6)	0002 : +2°C (Floor type 0000: 0°C)
0F	Cooling only	0000 : Heat pump 0001 : Cooling only (No display of [AUTO] [HEAT])	0000 : Shared for cooling/ heating
10	Type	0000 : (Air discharge cassette 1) 0001 : (Air discharge cassette 4) to 0037	According to model type
11	Indoor unit capacity	0000 : Unfixed 0001 to 0034	According to capacity type
12	Line address	0001 : No.1 unit to 0030 : No.30 unit	0099 : Unfixed
13	Indoor unit address	0001 : No.1 unit to 0064 : No.64 unit	0099 : Unfixed
14	Group address	0000 : Individual 0002 : Sub of group 0001 : Master of group	0099 : Unfixed
19	Flap type (Adjustment of air direction)	0000 : No flap 0004 : 4-way 0001 : Swing only	According to type
1E	Temp difference of automatic cooling/heating mode selection COOL → HEAT, HEAT → COOL	0000 : 0 deg to 0010 : 10 deg (For setup temperature, reversal of COOL/HEAT by ± (Data value)/2)	0003 : 3 deg (Ts±1.5)
28	Automatic reset of power failure	0000 : None 0001 : Reset	0000 : None
2A	Option		0002 : Default
2b	Thermo output selection (T10 ㉓)	0000 : Indoor thermo ON 0001 : Output of outdoor comp-ON receiving	0000: Thermo. ON
2E	Option		0000 : Default
30	Option		0000 : Default
31	Option		0000 : Default
32	Sensor selection	0000 : Body TA sensor 0001 : Remote controller sensor	0000 : Body sensor
40	Option		0003 : Default
5d	High ceiling selection (Air volume selection)	0000 : Standard filter 0001 : Oil guard, Super-long life, Optical regenerative deodorization 0003 : High performance (65%), High performance (90%), High antibacterial performance (65%)	0000 : Standard
60	Timer set (Wired remote controller)	0000 : Available (Operable) 0001 : Unavailable (Operation prohibited)	0000 : Available
8b	Correction of high heat feeling	0000 : None 0001 : Correction	0000 : None

12-1-3. Cabling and Setting of Remote Controller Control

2-remote controller control (Controlled by two remote controllers)

One or multiple indoor units are controlled by two remote controllers.
(Max. 2 remote controllers are connectable.)

- 1 indoor unit is controlled by 2 remote controllers

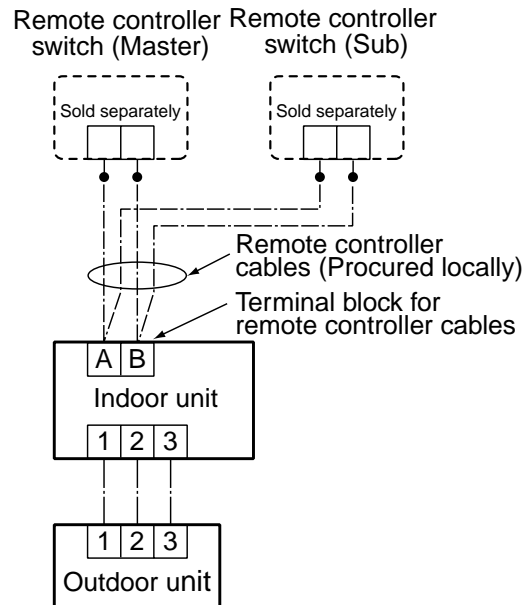

(Setup method)

One or multiple indoor units are controlled by two remote controllers.
(Max. 2 remote controllers are connectable.)

<Wired remote controller>

How to set wired remote controller to sub remote controller

Insert the remote controller address connector provided on the rear side of the remote controller switch P.C. board into Sub in exchange for Master.

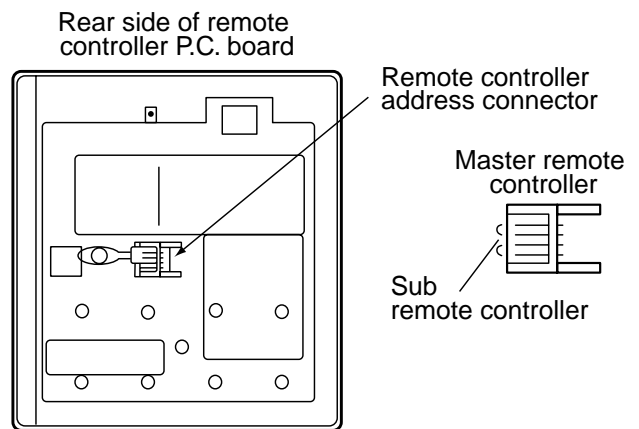

<Wireless remote controller>

How to set wireless remote controller to sub remote controller

Change OFF of Bit [3: Remote controller Sub/Master] of switch S003 to ON.

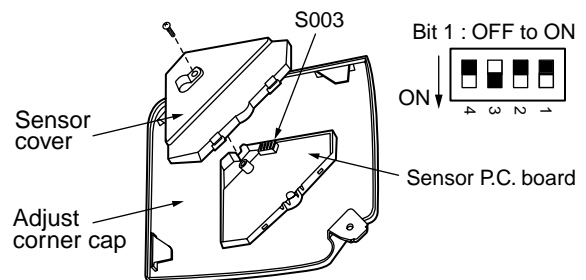

[Operation]

1. The operation contents can be changed by Last-push-priority.
2. Use a timer on either Master remote controller or Sub remote controller.

12-1-4. Monitor Function of Remote Controller Switch

■ Call of sensor temperature display

<Contents>

Each sensor temperature of the remote controller, indoor unit, and outdoor unit can become known by calling the service monitor mode from the remote controller.

<Procedure>

- 1 Push **CL** + **SET** buttons simultaneously for 4 seconds or more to call the service monitor mode.

The service monitor goes on, the master indoor unit No. is displayed, and then temperature of the item code **00** is displayed.

- 2 Push the temperature setup **▲** / **▼** buttons to select the sensor No. (Item code) of the sensor to be monitored.

The sensor numbers are described below:

	Item code	Data name		Item code	Data name
Indoor unit data	00	Room temp (under control) *1	Outdoor unit data	60	Heat exchanger temp TE
	01	Room temp (remote controller)		61	Outside temp TO
	02	Indoor suction temp		62	Discharge temp TD
	03	Indoor coil temp (TCJ)		63	Suction temp TS
	04	Indoor coil temp (TC)		64	—
			65	Heat sink temp THS	

*1 Only master unit in group control

- 3 The temperature of indoor units and outdoor unit in a group control can be monitored by pushing **UNIT** button to select the indoor unit to be monitored.
- 4 Pushing **CL** button returns the display to usual display.

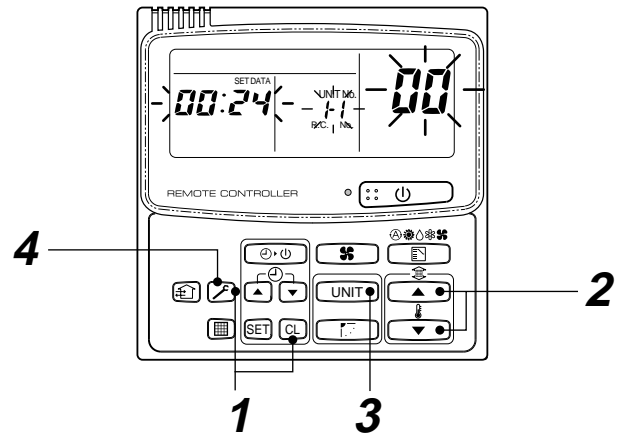

<Operation procedure>

1 → 2 → 3 → 4

Returned to usual display

■ Calling of error history

<Contents>

The error contents in the past can be called.

<Procedure>

- 1 Push + buttons simultaneously for 4 seconds or more to call the service check mode.

Service Check goes on, the **item code 01** is displayed, and then the content of the latest alarm is displayed. The number and error contents of the indoor unit in which an error occurred are displayed.

- 2 In order to monitor another error history, push the set temperature / buttons to change the error history No. (Item code).

Item code 01 (Latest) → Item code 04 (Old)

NOTE : Four error histories are stored in memory.

- 3 Pushing button returns the display to usual display.

<Requirement>

Do not push button, otherwise all the error histories of the indoor unit are deleted.

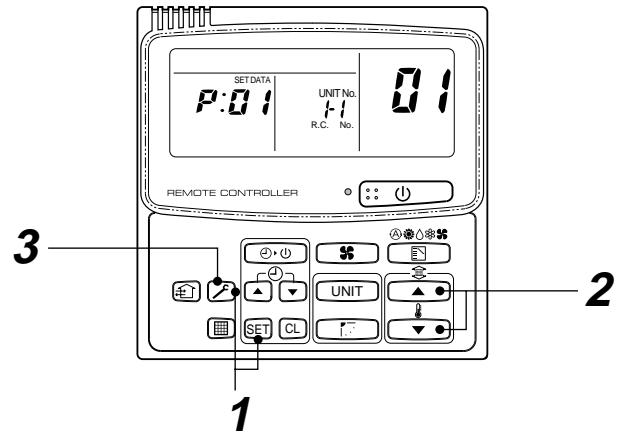

<Operation procedure>

1 → 2 → 3

Returned to usual display

(Group control operation)

In a group control, operation of maximum 8 indoor units can be controlled by a remote controller.

The indoor unit connected with outdoor unit (Individual/Master of twin) controls room temperature according to setting on the remote controller.

<System example>

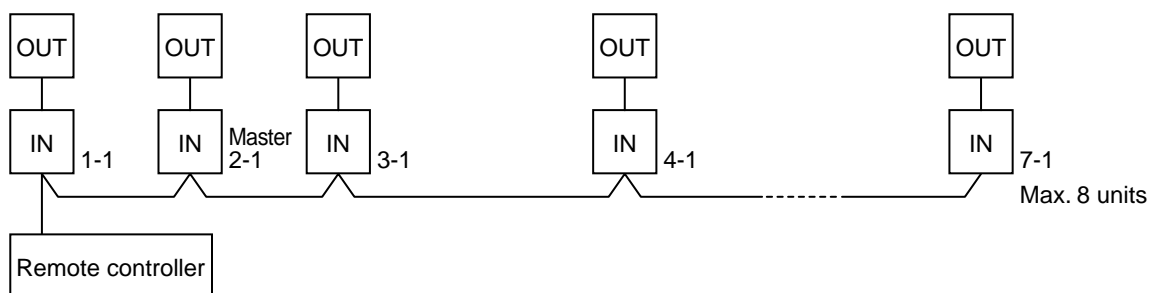

- (1) Display range on remote controller

The setup range (Operation mode/Air volume select/Setup temp) of the indoor unit which was set to the master unit is reflected on the remote controller.

- (2) Address setup

Turn on power of the indoor unit to be controlled in a group within 3 minutes after setting of automatic address.

If power of the indoor unit is not turned on within 3 minutes (completion of automatic address setting), the system is rebooted and the automatic address setting will be judged again.

- 1) Connect 3 In/Out cables surely.
- 2) Check line address/indoor address/group address of the unit one by one.
- 3) The unit No. (line/indoor gout address) which have been set once keep the present status as a rule if the unit No. is not duplicated with one of another unit.

12-2. Network Adapter

Model name: TCB-PCNT20E

12-2-1. Function

A network adapter is an optional P.C. board to connect the indoor unit to AI net (Central control remote controller).

12-2-2. Microcomputer Block Diagram

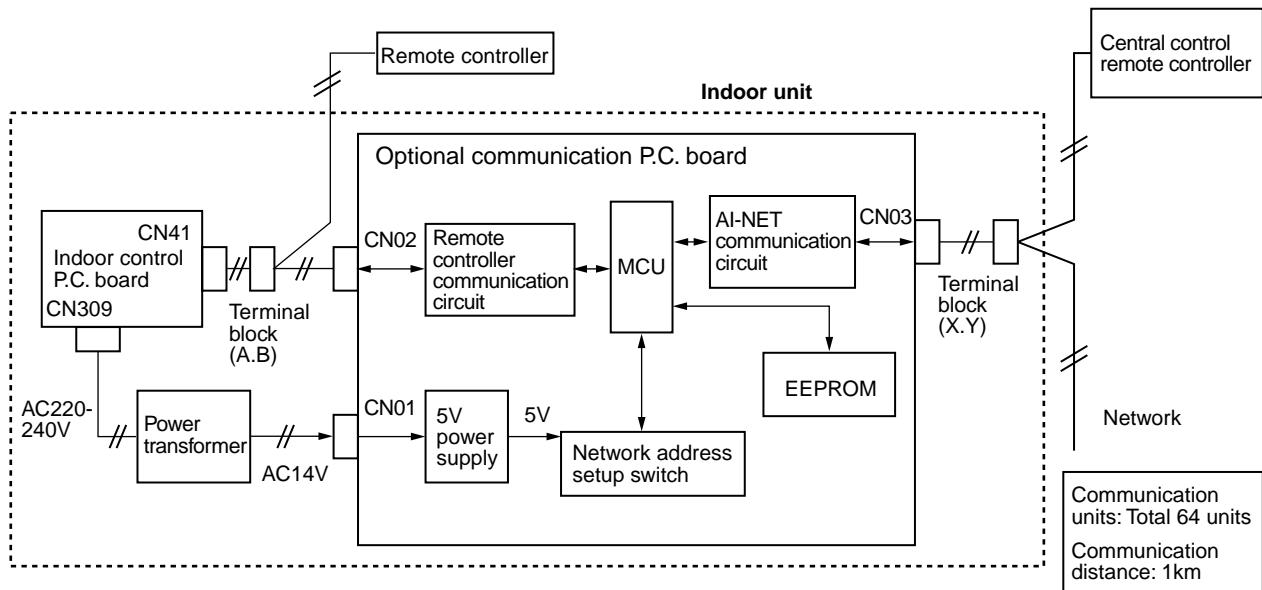

12-2-3. Network Address Setup Switch (SW01)

No.	Item	Setup contents
1	Central control address	1 2 3 4 5 6
2		: No.1 unit : Switch OFF
3		: No.2 unit : Switch OFF
4		:
5		: No.63 unit
6		: No.64 unit
7	Setup availability from remote controller	Switch OFF : Setup available from remote controller
8		Switch ON : Setup unavailable from remote controller

12-2-4. LED Display Specification

LED No.	Function	Go on	Go off
D01 (Red)	Communication status: Remote controller	During communication	No communication (including communication error)
D02 (Red)	Communication status: Center	During communication	No communication (including communication error)
D03 (Red)	Operation status of air conditioner	Running	Stop
D04 (Red)	Air conditioner error	Error	Normal

* For positions of LED, refer to P.C. board external view.

12-2-5. Communication Cable Specifications

No.	Communication circuit	Communication cable specifications	
1	Remote controller communication side	Cable	Neutral 2-cable type
		Cable type	CVV (JIS C3401) Controlling vinyl insulation vinyl seal cable VCTF (JIS C3306) Vinyl cab tire round type cord VCT (JIS C3401) 600V vinyl cab tire cable VVR (JIS C3401) Vinyl insulation seal cable round type MVVS Cable with net shielding for instrumentation CPEVS Shielded polyethylene insulation vinyl seal cable
		Cable dia.	0.5 to 2.0 mm ²
		Cable length	Total cable length Max. 500m (Up to 400m when there is wireless remote controller in group)
2	AI NET side	Cable	Neutral 2-cable type
		Cable type	MVVS Cable with net shielding for instrumentation
		Cable dia.	1.25 mm ² ≤ 500 m, 2.0 mm ² ≤ 1 km
		Cable length	Total cable length : Up to 500m when using 1.25mm ² cable, Up to 1000m when using 2.0mm ² cable

12-2-6. Cable Connection

<Network cable connection>

- Install a network adapter per 1 group of the group control (including single unit control). Also install a network adapter to one of the indoor units in the group control.

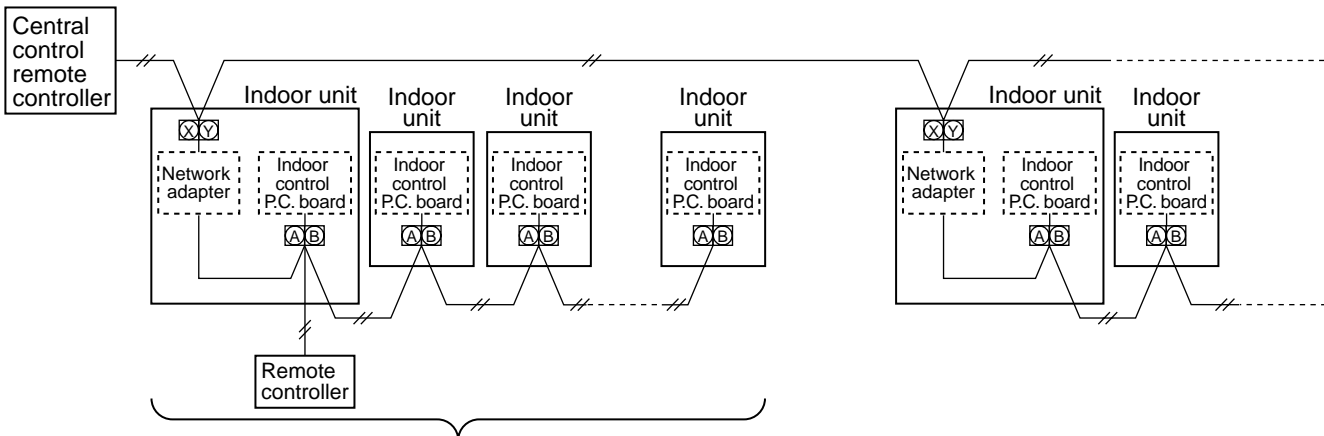

Connectable indoor units per group: Up to 8 units
(1-remote controller system*)
* In case of 2-remote controllers system,
the connectable indoor units are up to 7 units.

12-3. How to Set an Address Number

When connecting indoor units to the central control remote controller by using a network adapter, it is required to set up a network address No.

- The network address No. should be agreed with the line No. of the central control remote controller.
- When the unit was shipped from the factory, the network address has been set to 1.

The following two methods to set the network address are provided.

1. How to set from the remote controller at indoor unit side

* This method is effective only when ⑦ of set switch SW01 on the network adapter P.C. board is turned off.

<Procedure> Set the network address while the unit stops.

1 Push + buttons for 4 seconds or more.

In the group control, the unit No. *RLU* is displayed, and then all the indoor units in the group control are selected. In this time, fans of all the selected indoor units are turned on. (Fig. 1)

(Keep status of *RLU* display without pushing button.)

For the individual remote controller which is not included in a group control, the line address and the indoor unit address are displayed.

2 Specify the item code *03* using the temperature setup / buttons.

3 Using the timer time / buttons, select the setup data.

The setup data are shown in the right table (Table 1).

4 Push button. (OK if display goes on)

- To change the item to be set, return to **2**.

5 Push button.

The status returns to the usual stop status.

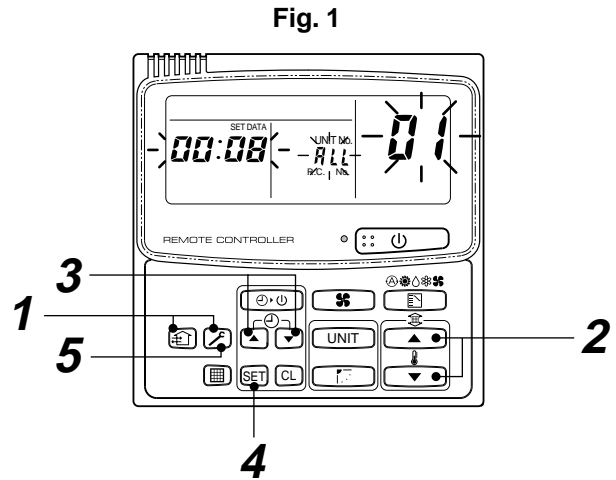

Table 1

Setup data	Network address No.
0001	1
0002	2
0003	3
⋮	⋮
0064	64
0099	Unset (Setup at shipment from factory)

2. How to set by the switch on the network adapter P.C. board

When the remote controller cannot be found or when you don't want to change setting of the network address No. from the remote controller, use the setup switch SW01 on the network adapter P.C. board (Network address No. setup switch) to set the address No.

<Procedure>

- (1) Turn off the power.
- (2) Turn ⑦ of the address No. setup switch SW01 to ON side. Accordingly the address No. set on the remote controller is invalidated. (See Fig. 2.)
- (3) Set the network address No. with combination of ON and OFF of ⑥ to ① of the address No. setup switch SW01. The relation between combination of ON/OFF and address No. is described in Table 2. The right figure (Fig. 3) shows an example of case that the address No. is set to 16.

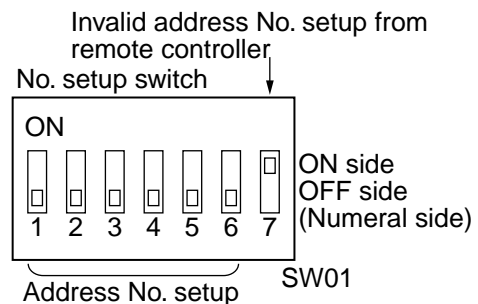

Fig. 2

Setup example of address No. 16



Fig. 3

When the network address No. has been changed, be sure to turn of power of the central control remote controller again or to reset the remote controller using the reset hole on the operation panel of the central control remote controller.

Table 2 Network address No. setup table (SW01)

: ON side
: OFF side

Address No.						
01						
02						
03						
04						
05						
06						
07						
08						
09						
10						
11						
12						
13						
14						
15						
16						
17						
18						
19						
20						
21						
22						
23						
24						
25						
26						
27						
28						
29						
30						
31						
32						

Address No.						
33						
34						
35						
36						
37						
38						
39						
40						
41						
42						
43						
44						
45						
46						
47						
48						
49						
50						
51						
52						
53						
54						
55						
56						
57						
58						
59						
60						
61						
62						
63						
64						

Requirement in Service

When using this product as service part to replace the network adapter P.C. board, be sure to match the setup of the setup switch SW01 (Network address No. setup switch) on the network adapter P.C. board with the P.C. board setup before replacement.

12-4. Display and Operation of Main Remote Controller and Central Control Remote Controller

- Turn on all the power supplies of the air conditioner, and then turn on power of the central control remote controller (Line 16 RBC-SXC1P, Line 64 TCB-SC641). If both power supplies are simultaneously turned on or if they are turned on reversely, the check code [97] may be temporarily displayed on the central remote controller. When settings of connecting cables and central control address are correct, the connected air conditioner is displayed on the central control remote controller.
- As shown in the following table, there is difference of LCD between main remote controller (RBC-AMT21) and the central control remote controller and also there are restriction and others of operation.

	Item	Contents		Cautions
		Main remote controller	Central control remote controller	
1	Air volume selection	[SPEED] [AUTO] [HH] [H] [L]	[VOL] [AUTO] [H] [M] [L]	Display of air speed selection differs.
		[SPEED] [HH]	[VOL] [FIX]	In duct type Air speed becomes [H] and [FIX].
2	Air speed selection in FAN mode	[SPEED] [HH] [H] [L]	[VOL] [AUTO] [H] [M] [L]	When handling main remote controller, [AUTO] is not displayed. If [AUTO] is selected at center side, [AUTO] is displayed on the main remote controller. In this time, the air speed becomes [HH].
3	Air speed selection in DRY mode	[SPEED] [AUTO] [HH] [H] [L]	[VOL] [AUTO]	On the central remote controller, only [AUTO] is displayed. The display on the main remote controller changes to [AUTO] by changing the setup temperature/louver, and the air speed is automatically selected.
4	Air direction adjustment	[SWING] and air direction adjustment	[LOUVER]	On the central remote controller, only [LOUVER] is displayed. It is displayed while flap is swinging, and the setup operation of [LOUVER] becomes selection of swing ON/OFF. To set up the air direction, use the main remote controller.
		(No display)	Manual operation for [LOUVER]	In a model type without air direction adjustment
5	Check button	Test run (4 seconds)	Check code display and check reset (3 seconds)	The function of long-pushing operation for the check button differs. If the check reset operation on the central remote controller is performed during operation of air conditioner, the operation stops once, and then the operation restarts. (Error of air conditioner is cleared.)
6	Check code	3-digits display (alphabet + 2-digits numeral)	2-digits display (alphabet or numeral)	Display of check code differs. Ex. : Float switch operation Main side: [P10] Center side: [0b]

- When using the remote controller together with the former one (RBC-AM1, AT1), the display on the main remote controller differs if [Last-push priority/Center/Operation Prohibited] is selected from the central control remote controller.

	Item	Contents		Remarks
		New remote controller (RBC-AMT21)	Former remote controller (RBC-AM1, AT1)	
1	Last-push priority	(No display)	(No display)	All the settings and ON/OFF operations are available.
2	Center	[CENTER] goes on	[CENTER] goes on	The setup contents on the central control remote controller are fixed, and only ON/OFF operation and timer setup operation are available on the main remote controller.
3	Operation prohibited		[CENTER] flashes	The setup contents on the central control remote controller are fixed, and the air conditioner stops. Operation from the main remote controller is unavailable.

13. ADDRESS SETUP

13-1. Address Setup

<Address setup procedure>

When an outdoor unit and an indoor unit are connected, or when an outdoor unit is connected to each indoor unit respectively in the group operation even if multiple refrigerant lines are provided, the automatic address setup completes with power-ON of the outdoor unit. The operation of the remote controller is not accepted while automatic address works. (Approx. 4 to 5 minutes)

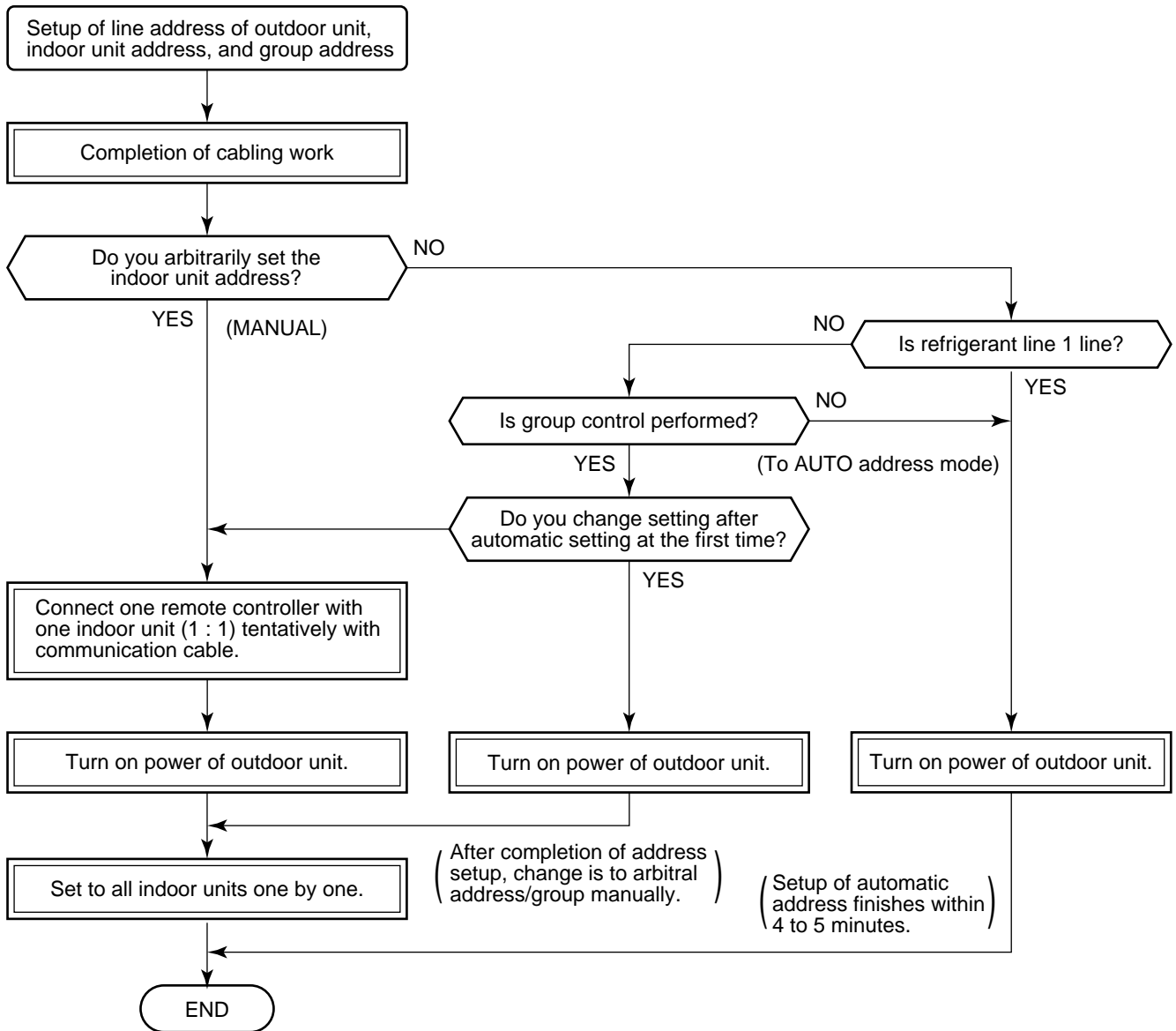

- When the following addresses are not stored in the neutral memory (IC10) on the indoor P.C. board, a test run operation cannot be performed. (Unfixed data at shipment from factory)

	Item code	Data at shipment	Setup data range
Line address	12	0099	0001 (No. 1 unit) to 0030 (No. 30 unit)
Indoor unit address	13	0099	0001 (No. 1 unit) to 0030 (No. 30 unit) Max. value of indoor units in the identical refrigerant line (Double twin = 4)
Group address	14	0099	0000 : Individual (Indoor units which are not controlled in a group) 0001 : Master unit (1 indoor unit in group control) 0002 : Sub unit (Indoor units other than master unit in group control)

13-2. Address Setup & Group Control

<Terminology>

Indoor unit No. : $N - n =$ Outdoor unit line address N (Max. 30) - Indoor unit address n (Max. 64)

Group address : 0 = Individual (Not group control)

1 = Master unit in group control

2 = Sub unit in group control

Master unit (= 1) : The representative of multiple indoor units in group operation sends/receives signals to/from the remote controllers and sub indoor units. (* It has no relation with an indoor unit which communicates serially with the outdoor units.)

The operation mode and setup temperature range are displayed on the remote controller LCD. (Except sir direction adjustment of flap)

Sub unit (= 2) : Indoor units other than master unit in group operation

Basically, sub units do not send/receive signals to/from the remote controllers. (Except errors and response to demand of service data)

13-2-1. System configuration

1. Single

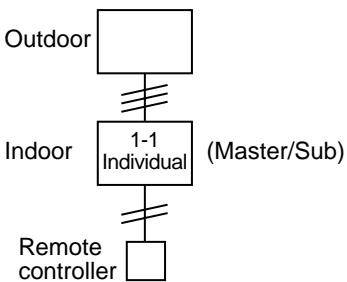

2. Single group operation

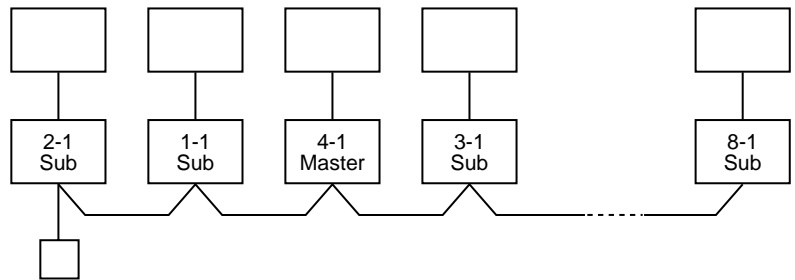

13-2-2. Automatic address example from unset address (No miscabling)

1. Standard (One outdoor unit)

1) Single

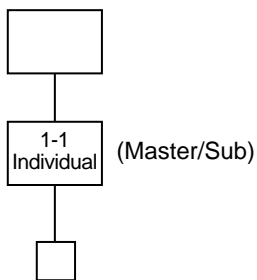

2) Gr operation

(Multiple outdoor units = Multiple indoor units only with serial communication)

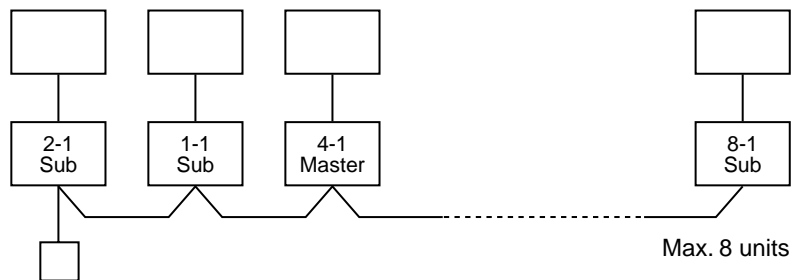

Only turning on source power supply (Automatic completion)

13-3. Address Setup

In case that addresses of the indoor units will be determined prior to piping work after cabling work
(Manual setting from remote controller)

<Address setup procedure>

- Set an indoor unit per a remote controller.
- Turn on power supply.

- 1** Push **SET** + **END** + **1** buttons simultaneously for 4 seconds or more.
- 2** (← Line address) Using the temperature setup **▲** / **▼** buttons, set **1** to the item code.
- 3** Using timer time **▲** / **▼** buttons, set the line address.
- 4** Push **SET** button. (OK when display goes on.)
- 5** (← Indoor unit address) Using the temperature setup **▲** / **▼** buttons, set **1** to the item code.
- 6** Using timer time **▲** / **▼** buttons, set **1** to the line address.
- 7** Push **SET** button. (OK when display goes on.)
- 8** (← Group address) Using the temperature setup **▲** / **▼** buttons, set **1** to the item code.
- 9** Using timer time **▲** / **▼** buttons, set **0000** to Individual, **0001** to Master unit, and **0002** to sub unit.
- 10** Push **SET** button. (OK when display goes on.)
- 11** Push **END** button.
Setup completes.
(The status returns to the usual stop status.)

(Example of 2-lines cabling)
(Real line: Cabling, Broken line: Refrigerant pipe)

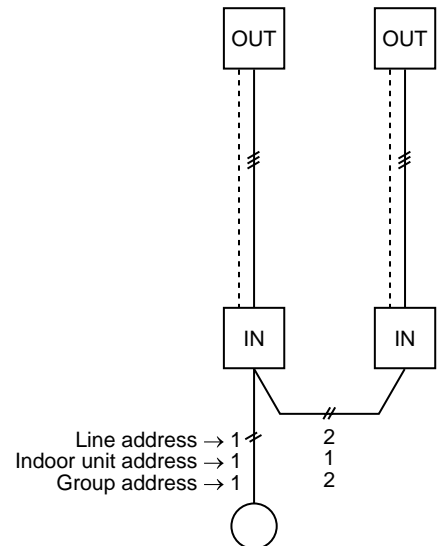

For the above example, perform setting by connecting singly the wired remote controller without remote controller inter-unit cable.

Group address
Individual : 0000
Master unit : 0001
Sub unit : 0002 } In case of group control

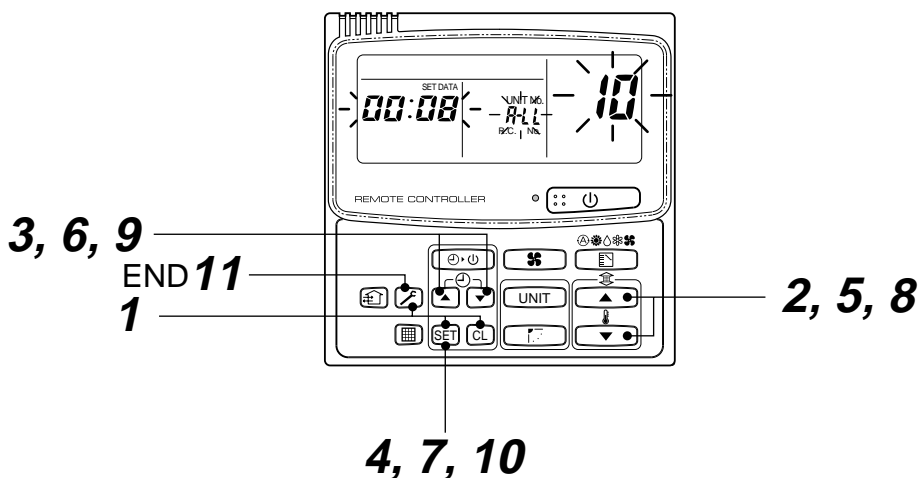

<Operation procedure>

1 → 2 → 3 → 4 → 5 → 6 → 7 → 8 → 9 → 10 → 11 END

■ Confirmation of indoor unit No. position

1. To know the indoor unit addresses though position of the indoor unit body is recognized

- In case of individual operation (Wired remote controller : indoor unit = 1 : 1)
(Follow to the procedure during operation)

<Procedure>

1 Push  button if the unit stops.

2 Push  button.

Unit No. /-/- is displayed on LCD.

(It disappears after several seconds.)

The displayed unit No. indicate line address and indoor unit address.

(When other indoor units are connected to the identical remote controller (Group control unit), other unit numbers are also displayed every pushing  button.

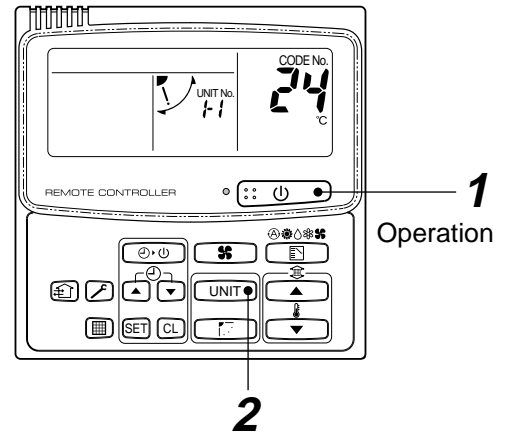

<Operation procedure>

1 → 2 END

2. To know the position of indoor unit body by address

- To confirm the unit No. in the group control
(Follow to the procedure during operation) (in this procedure, the indoor units in group control stop.)

<Procedure>

The indoor unit numbers in the group control are successively displayed, and fan, flap, and drain pump of the corresponding indoor unit are turned on. (Follow to the procedure during operation)

1 Push  and  buttons simultaneously for 4 seconds or more.

- Unit No. ALL is displayed.
- Fans and flaps of all the indoor units in the group control operate.

2 Every pushing  button, the unit numbers in the group control are successively displayed.

- The unit No. displayed at the first time indicates the master unit address.
- Fan and flap of the selected indoor unit only operate.

3 Push  button to finish the procedure. All the indoor units in the group control stop.

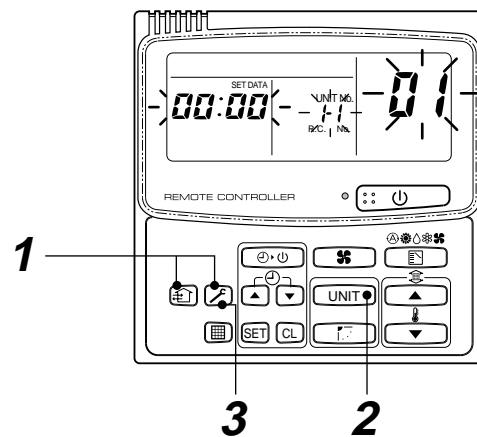

<Operation procedure>

1 → 2 → 3 END

RAV-SM800AT-E LED display when SW800 : Bit 1, 2, 3, 4 OFF

- When multiple errors are detected, the latest error is displayed.
- While LED displays (go on), there is the main cause of error in control at CDB side and it stops abnormally.
- While LED displays (flash), there is the main cause of error in control at IPDU side and it stops abnormally.
- For an error in case thermo operation, the communication is interrupted on the serial circuit. If continuing the case thermo operation, serial sending to the indoor unit is interrupted and a serial communication error is output.

Table A

	No.	Item	Check code	LED display			
			B type	D800 (Red)	D801 (Yellow)	D802 (Yellow)	D803 (Yellow)
CDB side	1	TE sensor error	18				
	2	TD sensor error	19				
	3	TS sensor error	18				
	4	TO sensor error	1B				
	5	Discharge temp error	1E				
	6	Out DC fan error	1A				
	7	Communication error between IPDU (Abnormal stop)	1C				
	8	High-pressure release operation	21				
			—				
	9	EEPROM error	—				
10	Communication error between IPDU (No abnormal stop)	—					
IPDU side	11	G-Tr short-circuit protection	14				
	12	Detection circuit error	16				
	13	Current sensor error	17				
	14	Phase missing detection	17				
	15	Comp lock error	1D				
	16	Comp breakdown	1F				

: Go on, : Go off, : Flash (5 Hz)

14. TROUBLESHOOTING <WALL TYPE>

14-1. Summary of Troubleshooting

<Wired remote controller type>

1. Before troubleshooting

1) Required tools/instruments

- ⊕ and ⊖ screwdrivers, spanners, radio cutting pliers, nippers, push pins for reset switch
- Tester, thermometer, pressure gauge, etc.

2) Confirmation points before check

① The following operations are normal.

a) Compressor does not operate.

- Is not 3-minutes delay (3 minutes after compressor OFF)?
- Does not thermostat turn off?
- Does not timer operate during fan operation?
- Is not detected an overflow error?
- Is not outside high-temperature operation controlled in heating operation?

b) Indoor fan does not rotate.

- Does not cool air discharge preventive control work in heating operation?

c) Outdoor fan does not rotate or air speed changes.

- Does not high-temperature release operation control work in heating operation?
- Does not outside low-temperature operation control work in cooling operation?
- Is not defrost operation performed?

d) ON/OFF operation cannot be performed from remote controller.

- Is not during emergency operation?
- Is not the control operation performed from outside/remote side?

② Did you return the cabling to the initial positions?

③ Are connecting cables of indoor unit and remote controller correct?

2. Troubleshooting procedure

When a trouble occurred, check the parts along with the following procedure.



NOTE :

For cause of a trouble, power conditions or malfunction/erroneous diagnosis of microcomputer due to outer noise is considered except the items to be checked. If there is any noise source, change the cables of the remote controller and the signal line to shield cables.

(a) Outline of Judgment

A primary judgment to detect cause of error exists on the indoor unit or outdoor unit is performed in the following procedure.

<Judgment by flashing display on the indoor unit display part>

The indoor unit monitors operating status of the air conditioner, and if a protective circuit works, contents of the self-diagnosis are displayed with a block restricted to the following cases on the indoor unit display part.

Remote controller code	Block display	Contents of self-diagnosis	Check code
—	Operation lamp display flashes. (1Hz)	Power failure (In power ON)	—
00	Operation lamp display flashes. (5Hz)	Indoor P.C. board	0b to 0F, 11, 12, b5, b6
01	Operation/timer lamp displays flash. (5Hz)	Inter-unit cables/transmission system	04
02	Operation/defrost lamp displays flash. (5Hz)	Outdoor P.C. board	14 to 19, 1A, 1C
03	Operation/timer/defrost lamp displays flash. (5Hz)	Cycle system, etc.	1d, 1E, 1F, 21
—	—	—	1b, 8b

(b) Self-diagnosis by check code on the remote controller

Refer to “Judgment of error mode by check code on the remote controller”.

<Wireless remote controller type>

1. Before troubleshooting

- 1) Required tools/instruments
 - ⊕ and ⊖ screwdrivers, spanners, radio cutting pliers, nippers, etc.
 - Tester, thermometer, pressure gauge, etc.
- 2) Confirmation points before check
 - ① The following operations are normal.
 - a) Compressor does not operate.
 - Is not 3-minutes delay (3 minutes after compressor OFF)?
 - Does not thermostat turn off?
 - Does not timer operate during fan operation?
 - Is not outside high-temperature operation controlled in heating operation?
 - b) Indoor fan does not rotate.
 - Does not cool air discharge preventive control work in heating operation?
 - c) Outdoor fan does not rotate or air volume changes.
 - Does not high-temperature release operation control work in heating operation?
 - Does not outside low-temperature operation control work in cooling operation?
 - Is not defrost operation performed?
 - d) ON/OFF operation cannot be performed from remote controller.
 - Is not forced operation performed?
 - Is not the control operation performed from outside/remote side?
 - ② Did you return the cabling to the initial positions?
 - ③ Are connecting cables between indoor unit and receiving unit correct?

2. Troubleshooting procedure

When a trouble occurred, check the parts along with the following procedure.



NOTE :

For cause of a trouble, power conditions or malfunction/erroneous diagnosis of microcomputer due to outer noise is considered except the items to be checked. If there is any noise source, change the cable of the signal line to shield cable.

(a) Outline of Judgment

A primary judgment to detect cause of error exists on the indoor unit or outdoor unit is performed in the following procedure.

<Judgment by flashing display on the indoor unit display part>

The indoor unit monitors operating status of the air conditioner, and if a protective circuit works, contents of the self-diagnosis are displayed with a block restricted to the following cases on the indoor unit display part (Sensors).

Remote controller code	Block display	Contents of self-diagnosis	Check code
—	Operation lamp display flashes. (1Hz)	Power failure (In power ON)	—
00	Operation lamp display flashes. (5Hz)	Indoor P.C. board	0b to 0F, 11, 12, b5, b6
01	Operation/timer lamp displays flash. (5Hz)	Inter-unit cables/transmission system	04
02	Operation/defrost lamp displays flash. (5Hz)	Outdoor P.C. board	14 to 19, 1A, 1C
03	Operation/timer/defrost lamp displays flash. (5Hz)	Cycle system, etc.	1d, 1E, 1F, 21
—	—	—	1b, 8b

(b) Self-diagnosis by check code on the remote controller

In the wireless type models, the self-diagnosis for the protective circuit operation is performed by handling the remote controller. First change the operation mode of the remote controller, and then perform the self-diagnosis by the displayed contents of the remote controller and the existence of operation lamp flashing (5Hz) and buzzer sound (Pi, Pi, Pi). During self-diagnosis operation, the timer lamp usually flashes (5Hz).

① Selection of remote controller operation mode

1) Selection of service mode

Push the select button at lower side of the wireless remote controller with a tip of pencil, etc. for approx. 3 seconds or more. In this time, check that [00] is displayed on the room temp. display part and other displays go off.

2) Selection of normal mode

Push the reset button at lower side of the wireless remote controller with a tip of pencil, etc. In this time, check that ["AM"] display on the time display part flashes.

② Cautions in service

1) After service work, be sure to push the reset button to return the mode to normal mode.

2) After service by the check codes, turn off the power switch once and then turn on the switch to return the stored memory in microcomputer to the initial status.

(c) Self-diagnosis with remote controller

With the indoor unit control, self-diagnosis of protective circuit action can be done by turning the remote controller operation into service mode, operating the remote controller, observing the remote controller indicators and checking whether TIMER lamp flashes (5 Hz).

NOTE :

- To perform this self-diagnosis, the remote controller with the service code of 43069666 is required.

<How to select remote control operation mode>

1. Selecting service mode

Push the switch button provided on rear bottom of the wireless remote control with a tip of pencil for more than 3 seconds. Make sure the setting temperature “□□” is displayed on the display and other display is turned off.

2. Selecting ordinary mode



Push the all clear button (ACL) on the rear bottom of the wireless remote controller with a tip of pencil for more than 3 seconds. Make sure the operation mode display, wind volume display, clock display and setting temperature display are turned on and “:” of the clock display is flashing.

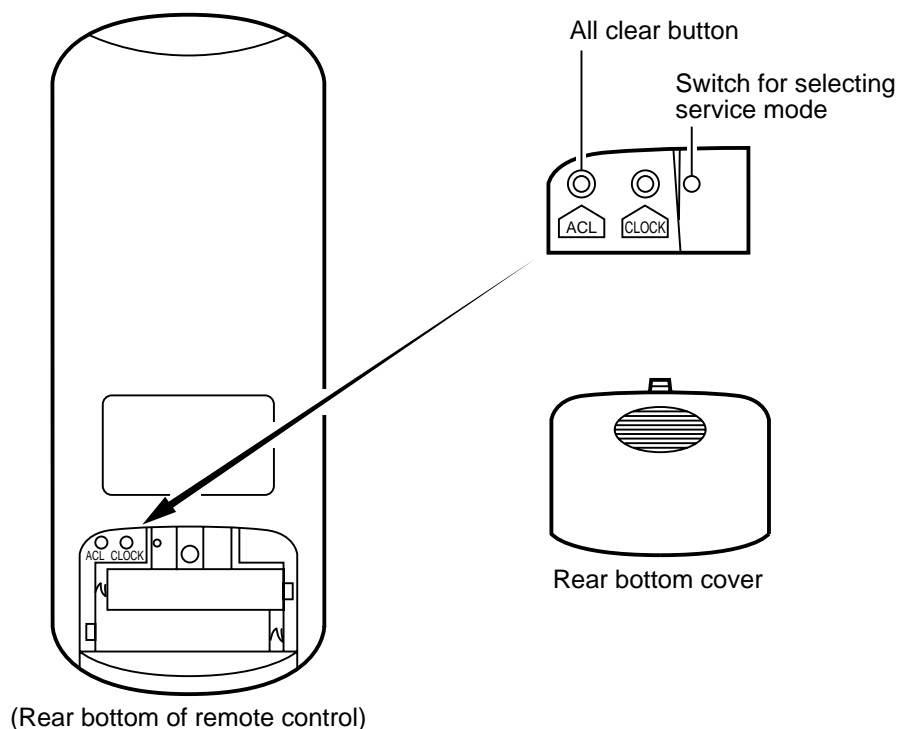

<Cautions when doing service>

1. After completion of servicing, always push the all clear (ACL) button to return the operation mode to the normal mode.
2. After completion of servicing by the check code, turn off the power once and then turn on the power to reset memorized contents of the microcomputer to the initial status.



<Self-diagnosis by check codes>

1. The self-diagnosis by the check codes is conducted under the block displays.
2. Remote controller key operation under the service mode is conducted by ON/OFF or TEMP. The remote controller display by each key operation is varied as shown below. Two digit number is displayed in a hexadecimal number.
3. The self-diagnosis by the check codes is conducted with procedures shown below.
 - 1) Enter the service mode and make sure the off timer display of the remote controller shows "00".
 - 2) Operate the "ON/OFF" key and make sure the timer lamp on the display section is flashing (5 Hz).
 - 3) At the same time, also make sure the operation lamp is also flashing. This shows that the protection circuit on the indoor P.C. board is working.
 - 4) Operate the TEMP.  key and make sure the remote controller display shows "01" and flashing of the operation lamp. If the operation lamp is flashing, it shows the protection circuits for connecting cable is working or thermal fuse is blown.
 - 5) In the same way, operate the TEMP.  key so that the display is increased one by one to continue checks by the self-diagnosis as shown in the next table. From "00" up to "03" check operations of protection circuits for each block, and "04" to "1F" check operations of the typical protection circuits.

Operating key	Indication after operation
ON/OFF	"00"
TEMP.  (Up)	1 is added to data before operation. (Example) "02" ⇒ "03"
TEMP.  (Down)	1 is subtracted from data before operation. (Example) "02" ⇒ "01"
"AUTO" LOUVER	10 is subtracted from data before operation. (Example) "02" ⇒ "12"
"SET" LOUVER	Data before operation is directly transferred. (Example) "02" ⇒ "02"

14-2. Troubleshooting with CHECK Display of Remote Controller

14-2-1. In case of main remote controller/sub-remote controller A

RBC-AM1E RBC-AS1E

1. Operation for CHECK display

When pushing the CHECK switch, the indoor unit No. (Group address No.) which sends the check code is displayed at the right side of the set up TEMP. display section, and the check data of 2 errors/faults x 16 units is displayed in the set up temp. display section.

If there is a filter display, the indoor unit No. which sends the filter signal is displayed at the right side of the set up temp. display section, and then the check code is displayed as described above.

(1 display for 3 seconds)

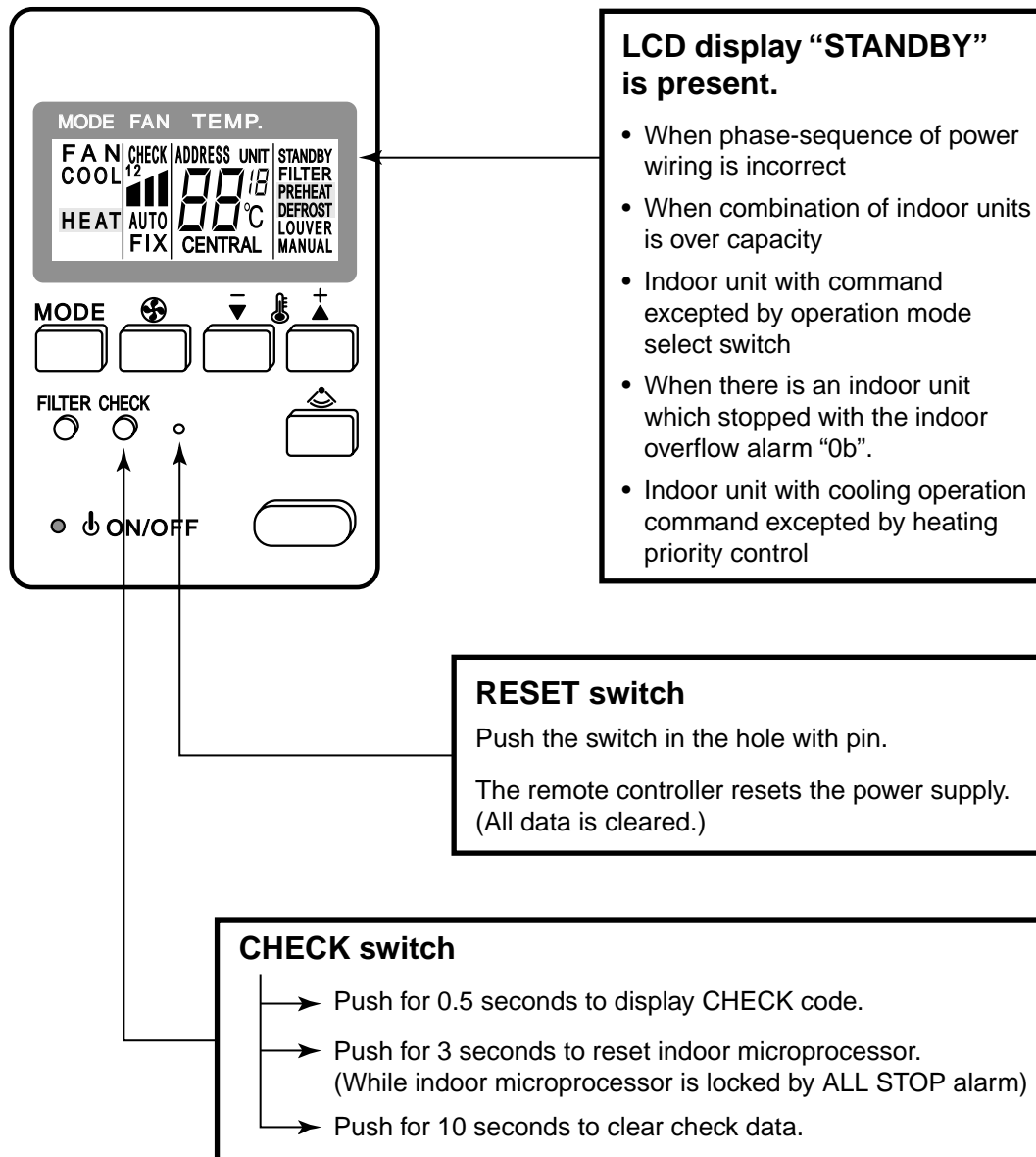

2. Reading of CHECK monitor display

<7 segment display>

0	1	2	3	4	5	6	7	8	9	A	B	C	d	E	F	Hexadecimal notation
0	1	2	3	4	5	6	7	8	9	10	11	12	13	14	15	Decimal notation

<Display on CHECK monitor>

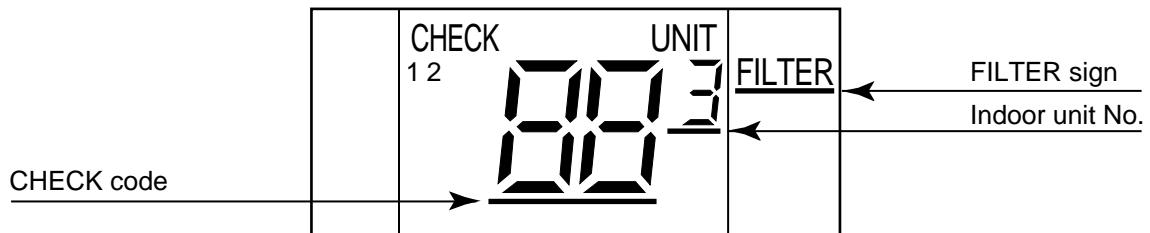

<FILTER data>

(Example) Case that Filter signal is sent from No.1 and No.16 units under group operation

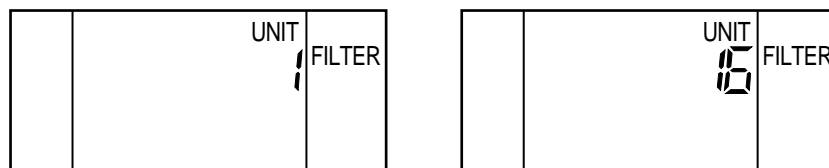

<CHECK data>

(Example) Room temp.sensor of No.1 is defective.
 In No.16, first the heat exchanger sensor has failed.
 Next, interconnection wire (serial signal line) of indoor/outdoor is defective.

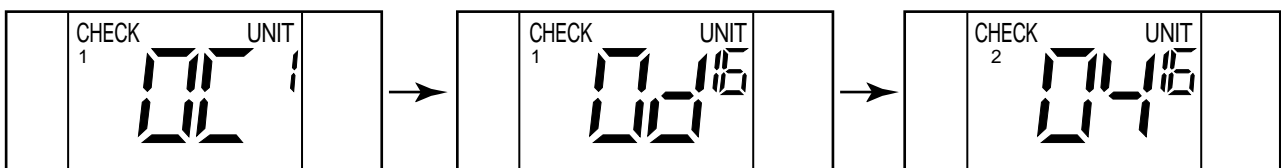

(Example) There is no check data.

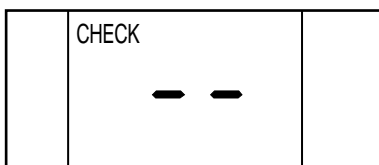

14-2-2. Remote controller with timer RBC-AM1E

1. Operation for CHECK display

When pushing the CHECK switch, the indoor unit No. (Group address No.) which sends the check code is displayed in the set up temp. display section, and check code is displayed in the TIME display section.

If FILTER display (air filter cleaning sign) is present, the indoor unit No. which sends the filter signal is displayed in the set up temp. display section, and then the check code is displayed. (1 display for 3 seconds)

LCD display STANDBY is present.

- When phase-sequence of power wiring is incorrect
- When combination of indoor units is over capacity.
- Indoor unit with command excepted by operation mode select switch
- When there is an indoor unit which stopped with the indoor overflow alarm "Ob".
- Indoor unit with cooling operation command excepted by heating priority control

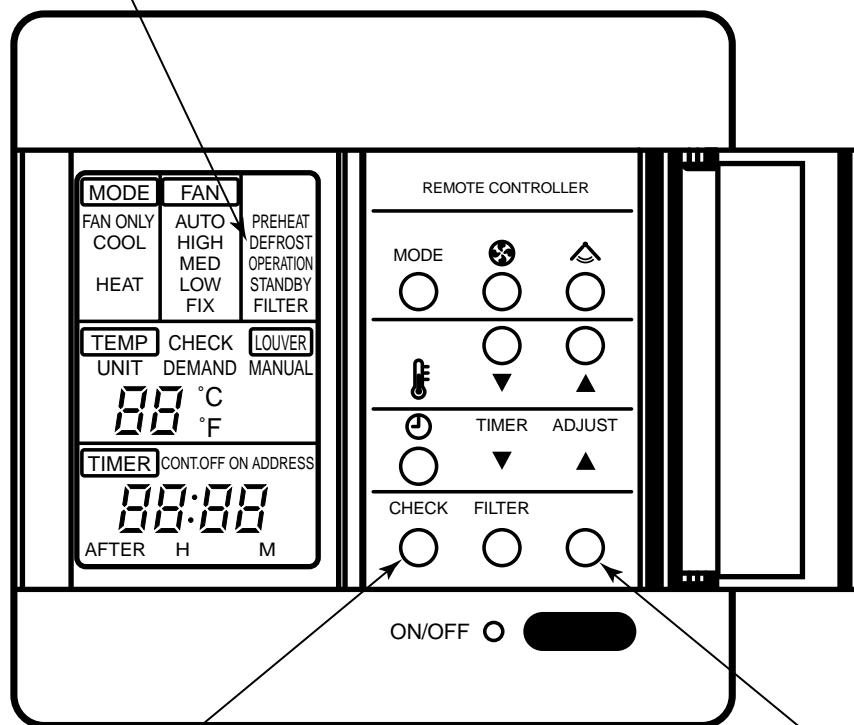

(This display is for remote control with timer.)

CHECK switch

- ➔ Push for 0.5 seconds to display CHECK code.
- ➔ Push for 3 seconds to reset indoor microprocessor. (While indoor microprocessor is locked by ALL STOP alarm)
- ➔ Push for 10 seconds to clear check data.

RESET switch

- ➔ Push the switch in the hole with pin. The remote controller resets initialized. (All data is cleared.)

2. Reading of CHECK monitor display

<7 segment display>

0	1	2	3	4	5	6	7	8	9	10	11	12	13	14	15	Hexadecimal notation
0	1	2	3	4	5	6	7	8	9	10	11	12	13	14	15	Decimal notation

<FILTER data>

(Example) Filter signal is sent from No.1 and No.15 units under grouping operation

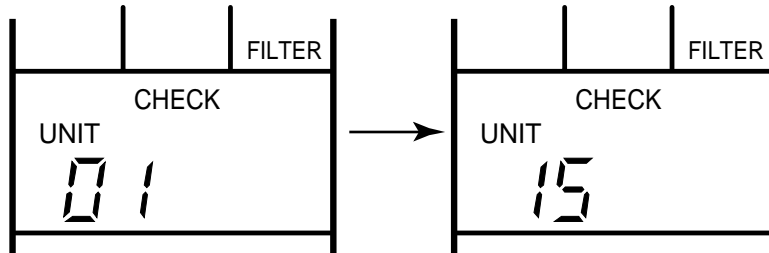

<CHECK data>

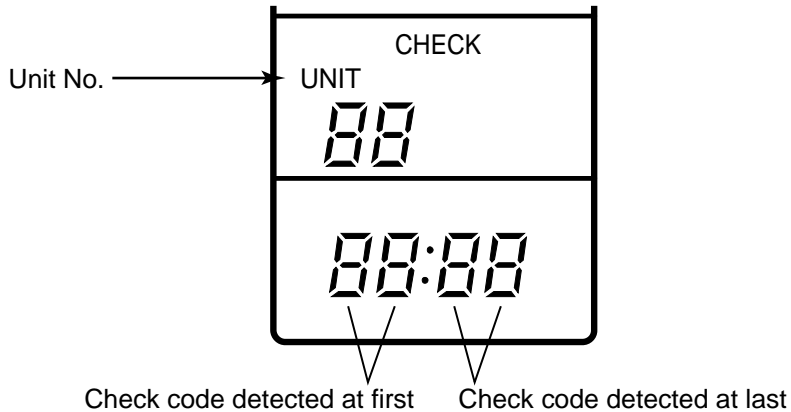

(Example) Room temp.sensor of No.1 is defective.
In No.15, first the indoor heat exchanger sensor has failed.
Next, interconnection wire (bus communication line) of indoor/outdoor is defective.

(Example) There is no check data.

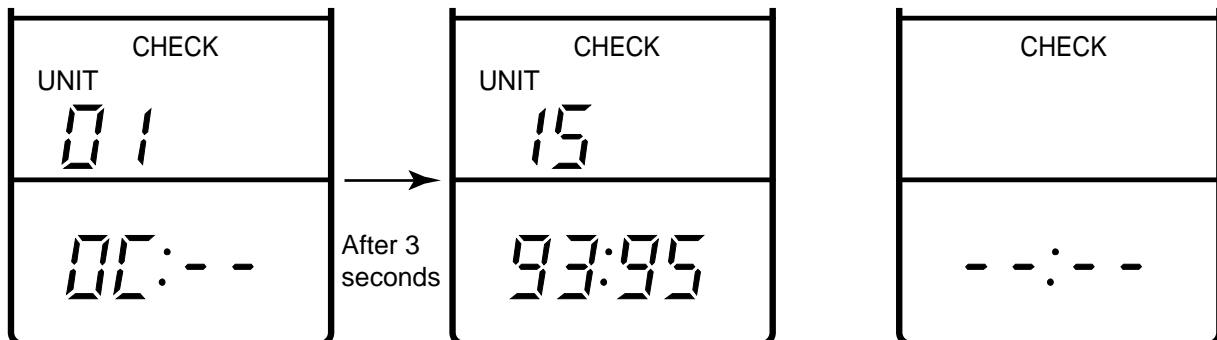

14-2-3. Central remote controller

1. Operation for CHECK display

When pushing the CHECK switch, the indoor unit No. (Network address No.) including the check data is displayed in the UNIT No. display section, and the check code is displayed in the set up temp. display section.

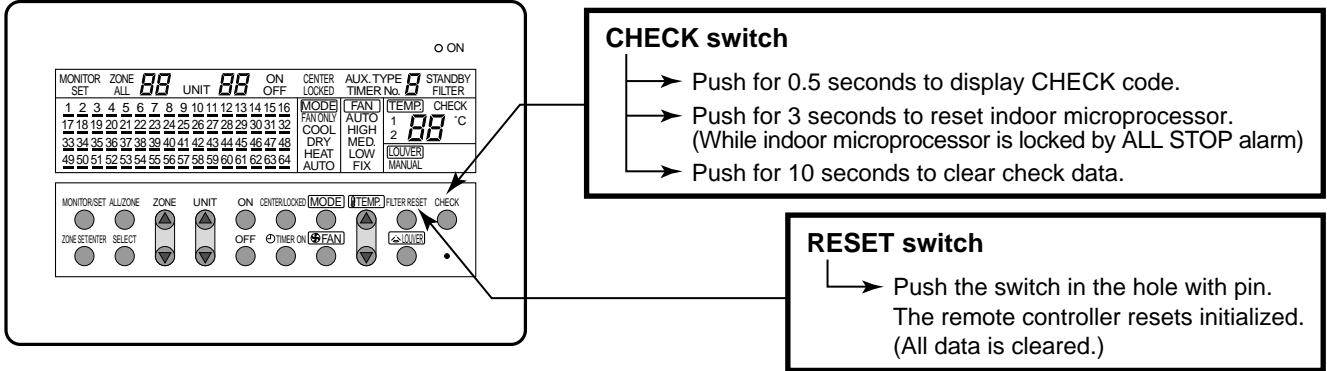

2. Reading of CHECK monitor display

<7 segment display>

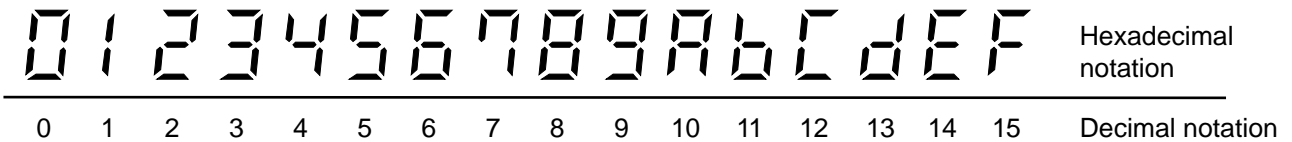

<Display on CHECK monitor>

Unit line No. (Network address No.)

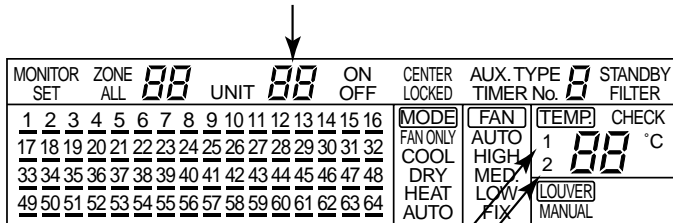

Check code detected at first

Check code detected at last

(Example)

There is no check data.

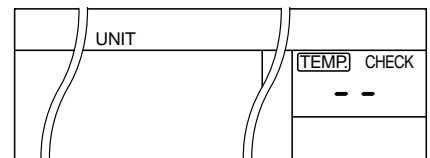

<CHECK data>

(Example)

In No.1 unit, first the interconnection wire (bus communication line) of indoor/outdoor has failed.

Next, the room temp. sensor is defective.

For No.16 unit, the high pressure switch at the inverter unit side operates.

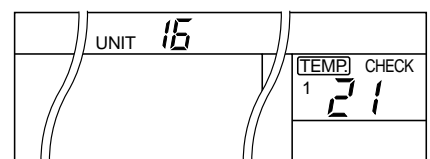
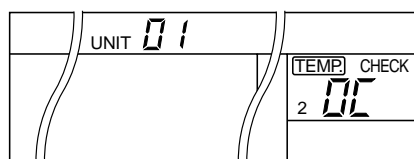
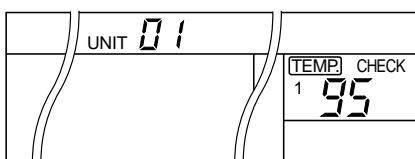

14-3. Check Code Table

Error mode detected by indoor unit (1)

Operation of diagnostic function					Judgment and measures
Block display	Check code	Cause of operation	Status of air conditioner	Condition	
[MODE] [TIMER] lamp 5Hz flash	04	The serial signal is not output from outdoor unit to indoor unit. <ul style="list-style-type: none"> Miscabling of inter-unit cables Defective serial sending circuit on outdoor P.C. board Defective serial receiving circuit on outdoor P.C. board Compressor case thermo operation 	Operation continues	Displayed when error is detected	<ol style="list-style-type: none"> Outdoor unit does not completely operate. <ul style="list-style-type: none"> Inter-unit cable check, correction of miscabling Outdoor P.C. board check, P.C. board cables check Compressor case thermo check In normal operation When outdoor sending serial LED (Green) flashes, the receiving serial LED (Orange) also flashes. : Indoor P.C. board (Main P.C. board) check When the receiving serial LED (Orange) does not flash: Outdoor P.C. board check
	97	BUS communication circuit error * BUS communication was interrupted over the specified time.	Operation continues (According to remote controller of indoor unit)	Displayed when error is detected	<ol style="list-style-type: none"> Communication line check, miscabling check Power supply check for central controller (Central control remote controller, etc.) and indoor unit Communication check (XY terminal) Indoor P.C. board check Central controller check (Communication P.C. board)
	98	Network address miss-setting <ul style="list-style-type: none"> Addresses of central controllers (Central control remote controller, etc.) are duplicated. 	Operation continues	Displayed when error is detected	<ol style="list-style-type: none"> Check central control system network address setting. (SW02) Indoor P.C. board check Central controller check (Communication P.C. board)
	08	Error in 4-way valve system <ul style="list-style-type: none"> Indoor heat exchanger temperature rise after start of cooling operation. Indoor heat exchanger temperature fall after start of heating operation. 	Operation continues	Displayed when error is detected	<ol style="list-style-type: none"> Check 4-way valve. Check 2-way valve and non-return valve. Check indoor heat exchanger sensor (TC). Check indoor P.C. board (Main P.C. board).
	09 *	Error in other cycles <ul style="list-style-type: none"> Indoor heat exchanger temp (TC) does not vary after start of cooling/heating operation. 	Operation continues	Displayed when error is detected	<ol style="list-style-type: none"> Compressor case thermo operation Coming-off of detection part of indoor heat exchanger sensor Check indoor heat exchanger sensor (TC). Check indoor P.C. board (Main P.C. board).
[MODE] lamp 5Hz flash	0C	Coming-off, disconnection or short of indoor temp sensor (TA)	Operation continues	Displayed when error is detected	<ol style="list-style-type: none"> Check indoor temp sensor (TA). Check indoor P.C. board (Main P.C. board).
	0d	Coming-off, disconnection or short of indoor temp sensor (TC)	Operation continues	Displayed when error is detected	<ol style="list-style-type: none"> Check indoor temp sensor (TC). Check indoor P.C. board (Main P.C. board).
	0F	Coming-off, disconnection or short of indoor temp sensor (TCJ)	Operation continues	Displayed when error is detected	<ol style="list-style-type: none"> Check indoor temp sensor (TCJ). Check indoor P.C. board (Main P.C. board).

* : No display in the setting at shipment

Error mode detected by indoor unit (1)

Operation of diagnostic function					Judgment and measures
Block display	Check code	Cause of operation	Status of air conditioner	Condition	
[MODE] lamp 5Hz flash	11	Error in indoor fan system Revolutions frequency error of fan	All stop	Displayed when error is detected	1. Check indoor fan motor connector circuit (CN210). 2. Check indoor fan. 3. Check indoor P.C. board (Main P.C. board).
	12	Error in indoor unit or other positions 1. EEPROM access error	Operation continues	Displayed when error is detected	
	b5	Outside error input Detected by input voltage level from outside devices	Operation continues	Displayed when error is detected	
	b6	Outside interlock input Detected by input voltage level from outside devices	All stop	Displayed when error is detected	

Error mode detected by indoor unit (2)

Operation of diagnostic function				Judgment and measures
Check code	Cause of operation	Status of air conditioner	Condition	
99	Serial return signal is not sent from No. 1 indoor unit to remote controller. • Miscabling of inter-unit cable between remote controller and indoor unit • Miss-setting of indoor unit No. (Group address)	ON/OFF	Displayed when error is detected	1. Indoor unit does not completely operate. • Check inter-unit cable. • Check indoor P.C. board. (Main/Sub P.C. boards) • Check remote controller. 2. In normal operation • Check setting of indoor unit No. (SW01) (Sub P.C. board) • Check remote controller.

Error mode detected by outdoor unit

Operation of diagnostic function				Judgment and measures
Check code	Cause of operation	Status of air conditioner	Condition	
14	Inverter over-current protective circuit operates. (For a short time)	All stop	Displayed when error is detected	1. Inverter immediately stops even if restarted. • Compressor rare short 2. Check IPDU. • Cabling error
17	Error on current detection circuit • Current value is high at AC side even while compressor stops. • Phase of power supply is missed.	All stop	Displayed when error is detected	1. Compressor immediately stops even if restarted. : Check IPDU. 2. Phase-missing operation of power supply • Check power voltage of R, S, T.
18	Coming-off, disconnection or short of outdoor temp sensor	All stop	Displayed when error is detected	1. Check outdoor temp sensor (TE, TS). 2. Check CDB.
19	Coming-off, disconnection or short of outdoor temp sensor	All stop	Displayed when error is detected	1. Check outdoor temp sensor (TD). 2. Check CDB.
1C	Compressor drive output error • Tin thermistor temp, Tin error (IPDU heat sink temp. is high.) Communication error between IPDU • Connector coming-off between CDB and IPDU	All stop	Displayed when error is detected	1. Abnormal overload operation of refrigerating cycle 2. Loosening of screws and contact error of IPDU and heat sink 3. Cooling error of heat sink 4. Check cabling of CDB and IPDU.
1D	Compressor does not rotate. (Over-current protective circuit works when constant time passed after activation of compressor.)	All stop	Displayed when error is detected	1. Compressor error (Compressor lock, etc.) : Replace compressor. 2. Cabling trouble of compressor (Phase missing)
1E	Discharge temp error • Discharge temp over specified value was detected.	All stop	Displayed when error is detected	1. Check refrigerating cycle. (Gas leak) 2. Error of electron control valve 3. Check pipe sensor (TD).
1F	Compressor breakdown • Operation frequency lowered and stops though operation had started.	All stop	Displayed when error is detected	1. Check power voltage. (AC200V±20V) 2. Overload operation of refrigerating cycle 3. Check current detection circuit at AC side.
21	High-voltage protection error by TE sensor • TE temp over specified value was detected.	All stop	Displayed when error is detected	1. Overload operation of refrigerating cycle 2. Check outdoor temp sensor (TE).
1A	DC outdoor fan motor error • IDC operation or lock was detected by DC outdoor fan driving.	All stop	Displayed when error is detected	1. Position detection error 2. Over-current protection circuit operation of outdoor fan drive unit • Check CDB. • Refer to Judgment of outdoor fan.
1B	Error on IPDU position detection circuit	All stop	Displayed when error is detected	1. Position detection circuit operates even if driving by removing 3P connector of compressor. • Replace IPDU.
1b	Coming-off, disconnection or short of outdoor temp sensor	Operation continues	Displayed when error is detected	1. Check outdoor temp sensor (TO). 2. Check P.C. board.

14-4. Troubleshooting for Each Check Code

[1A error]

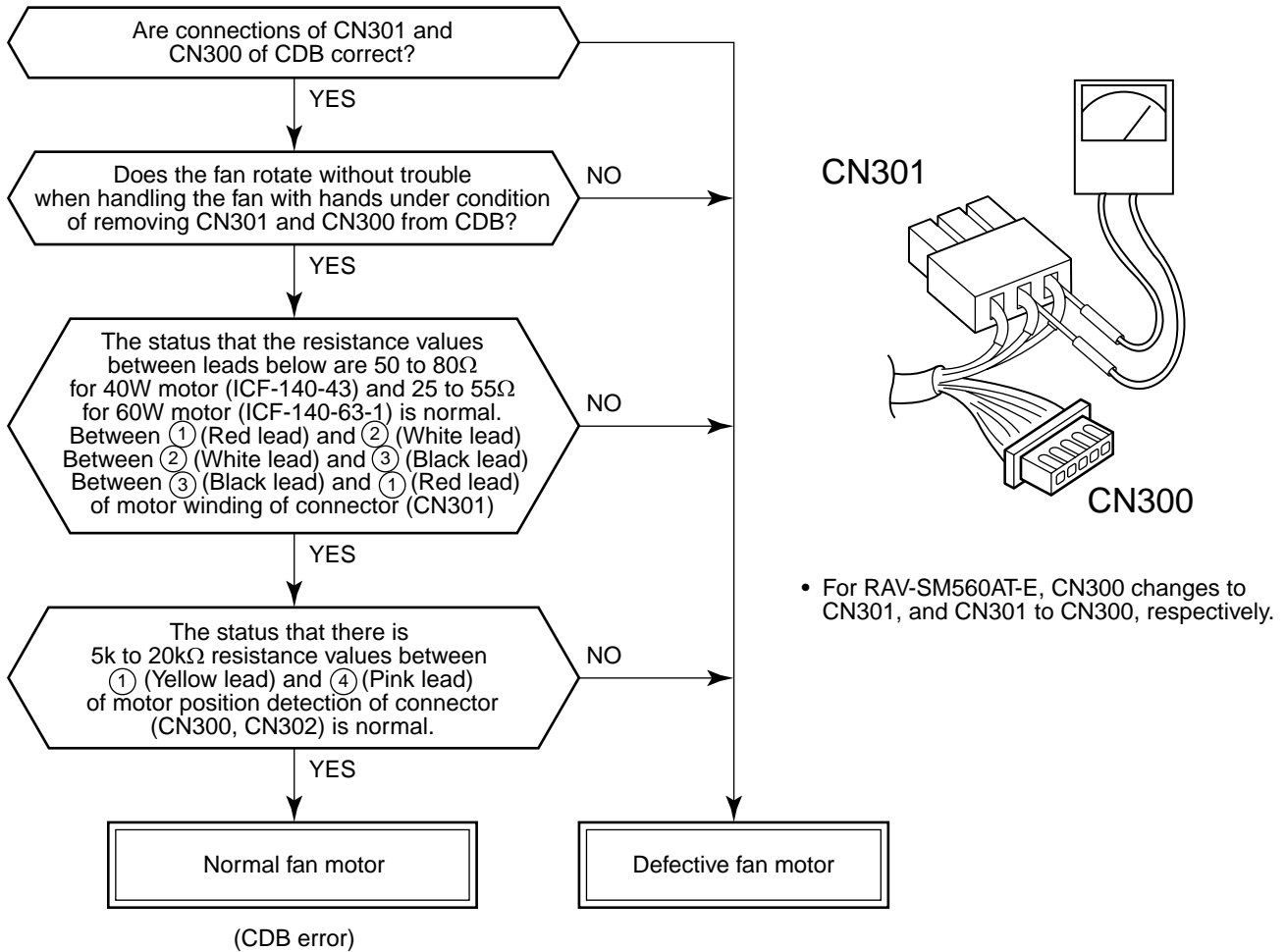

NOTE :

However, GND circuit error inside of the motor is rarely detected even if the above check is carried out. When the circuit does not become normal even if P.C. board has been replaced, replace outdoor fan motor.

	RAV-SM560AT-E	RAV-SM800AT-E
Objective P.C. board	Control P.C. board	CDB P.C. board
Fan motor winding	CN300	CN301
Motor position detection	CN301	CN300

[04 error]

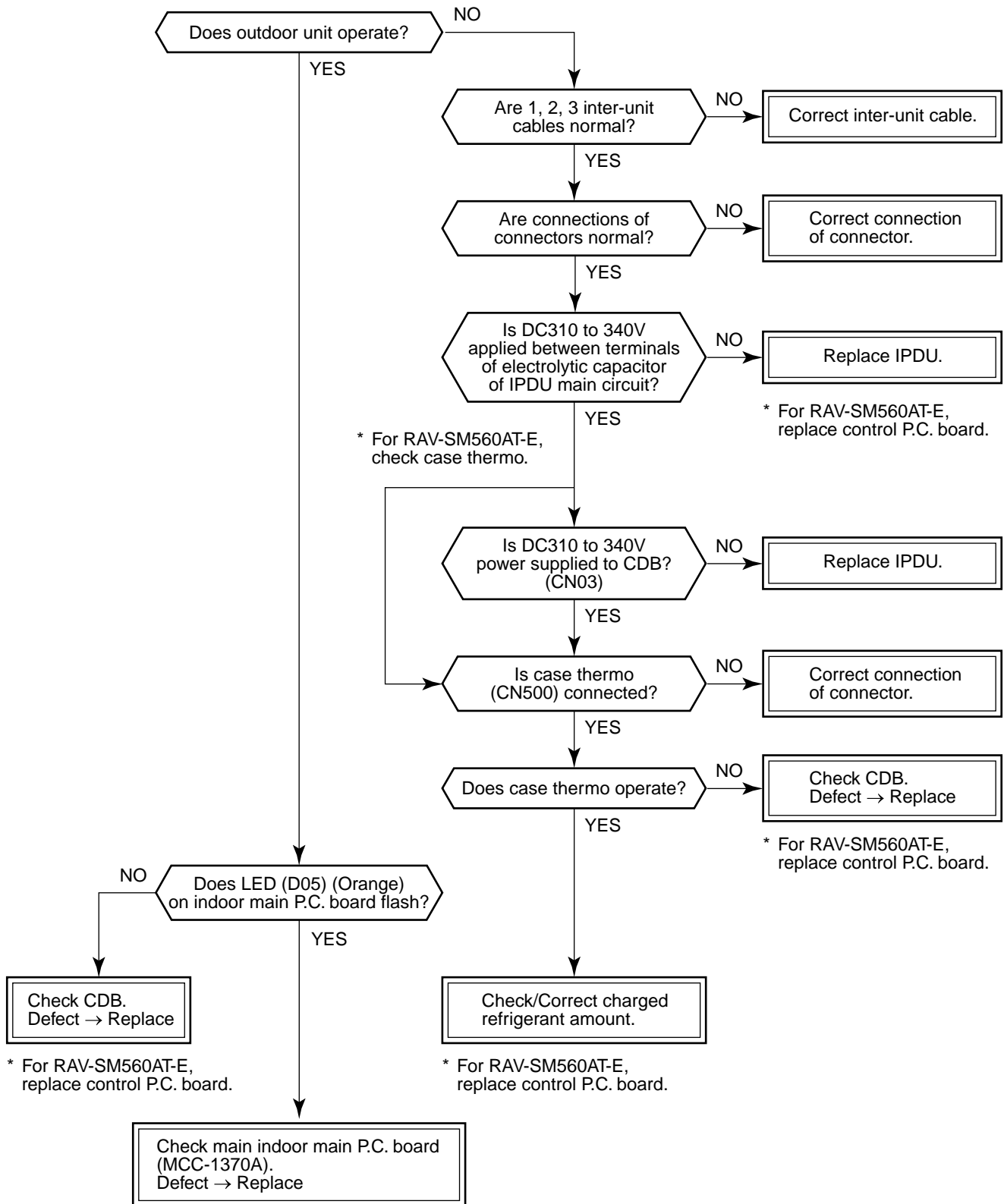

[08 error]

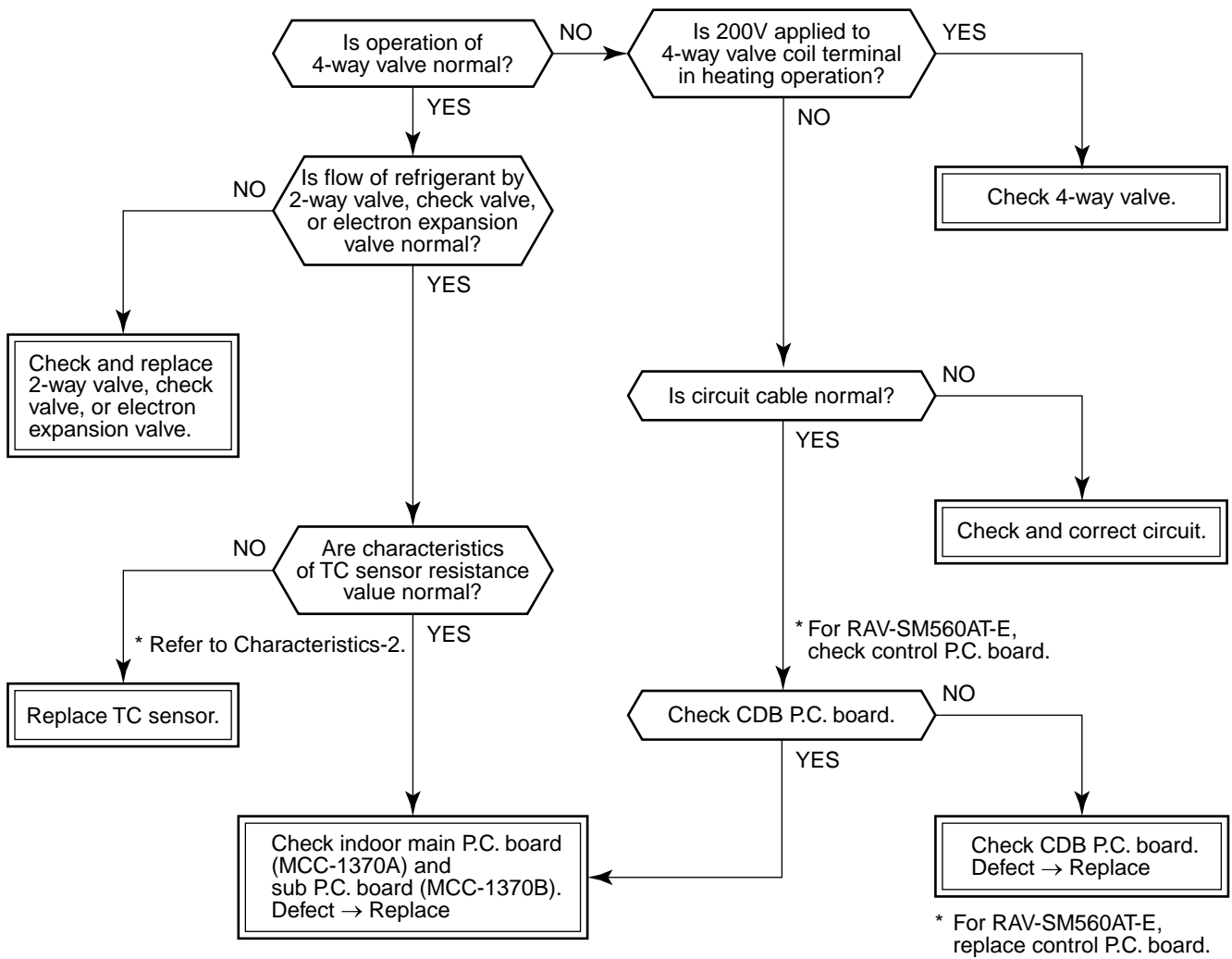

- In cooling operation, if high pressure is abnormally raised, [08 error] may be displayed. In this case, remove cause of pressure up and then check again referring to the item [21 error].

[0C error]

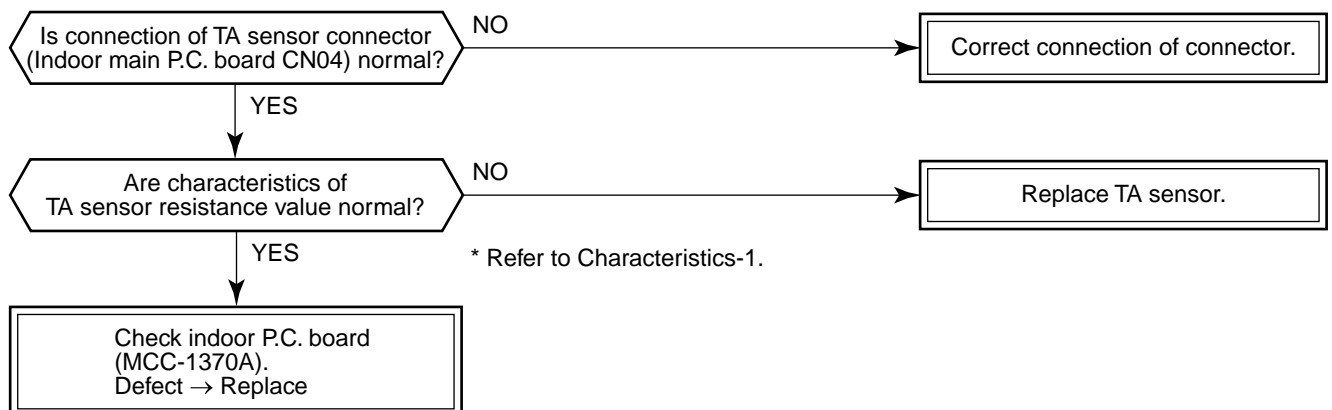

[0d error]

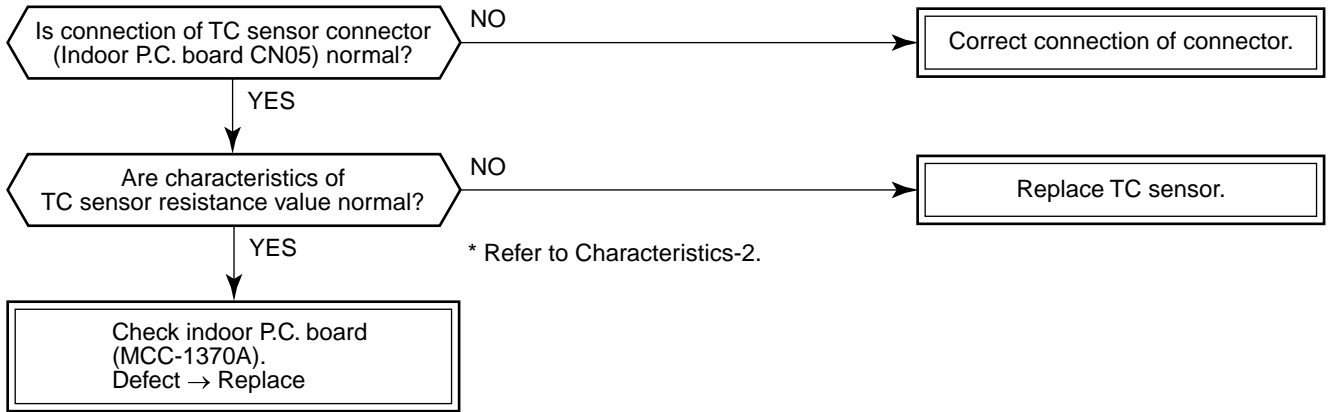

[0F error]

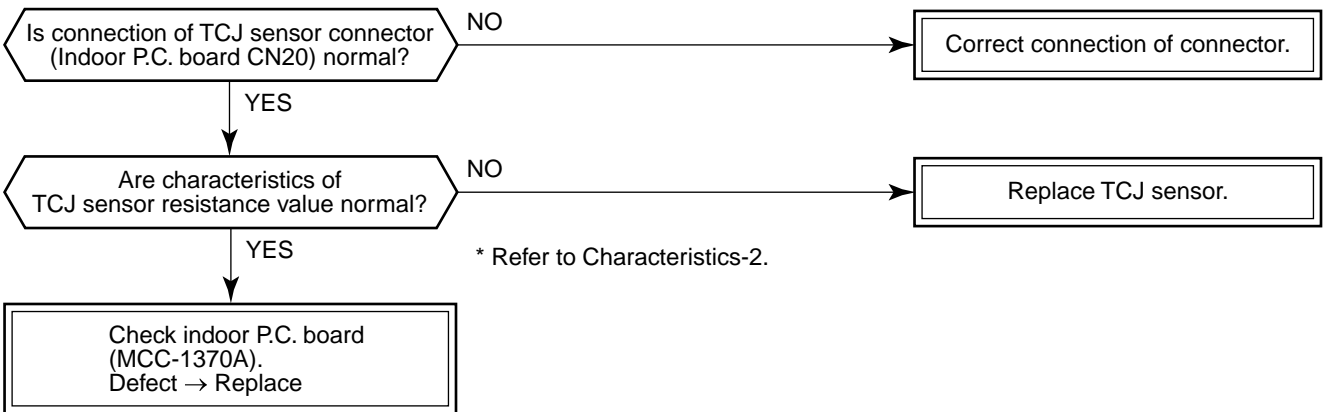

[99 error]

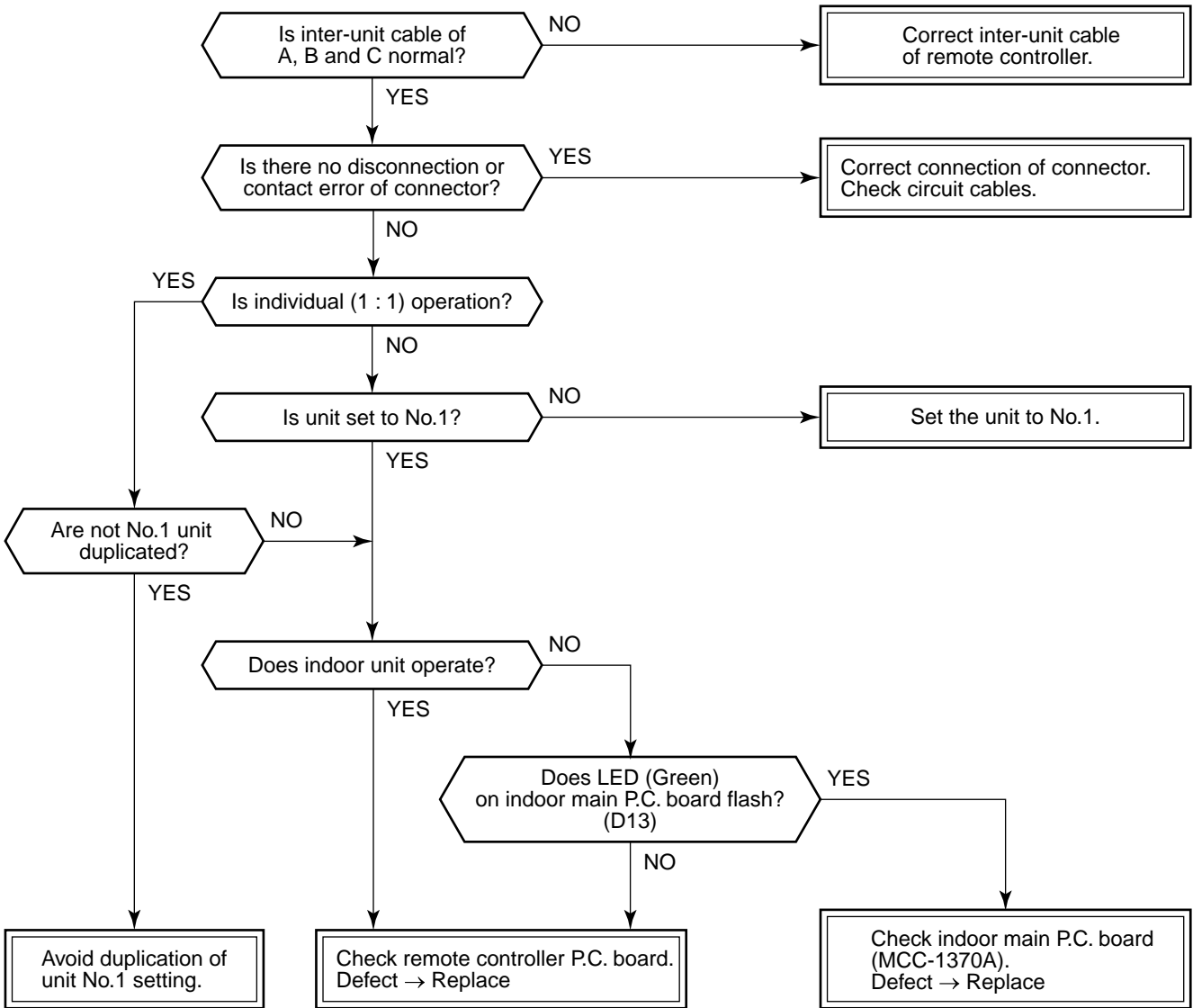

[11 error]

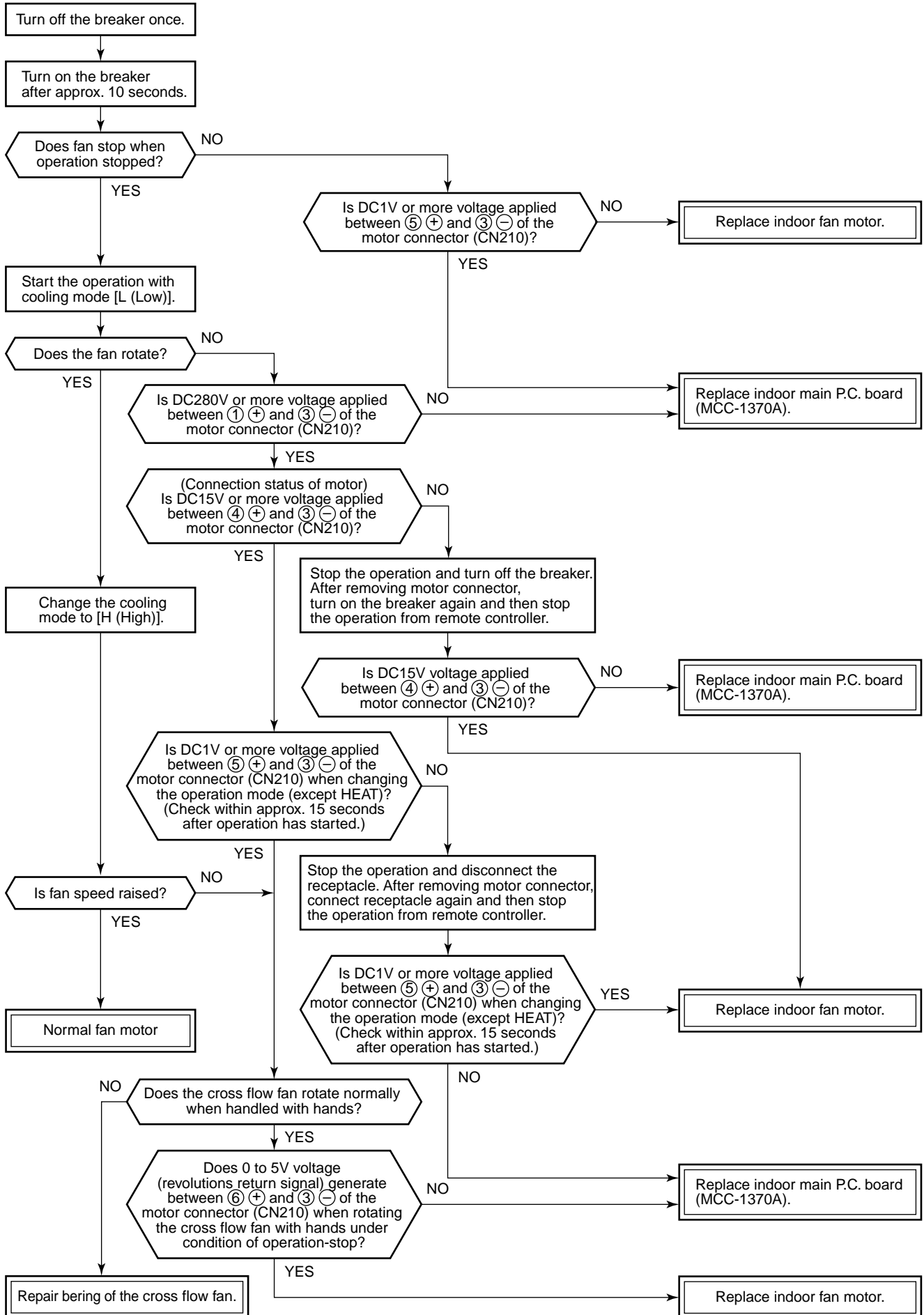

[11 error]

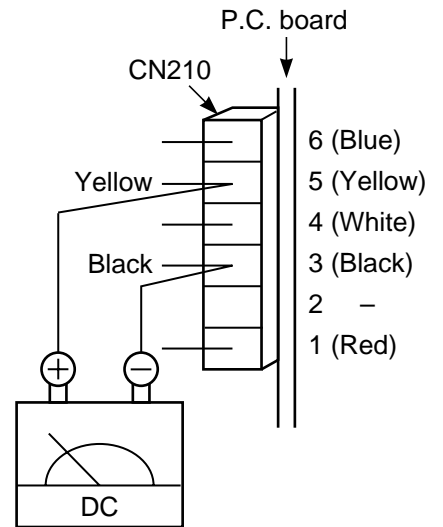
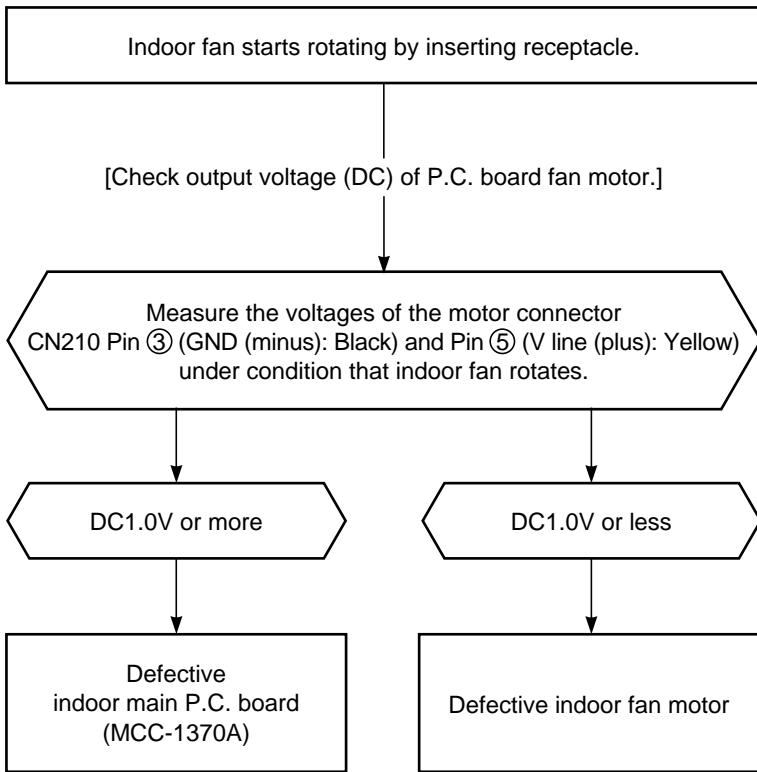

[12 error]

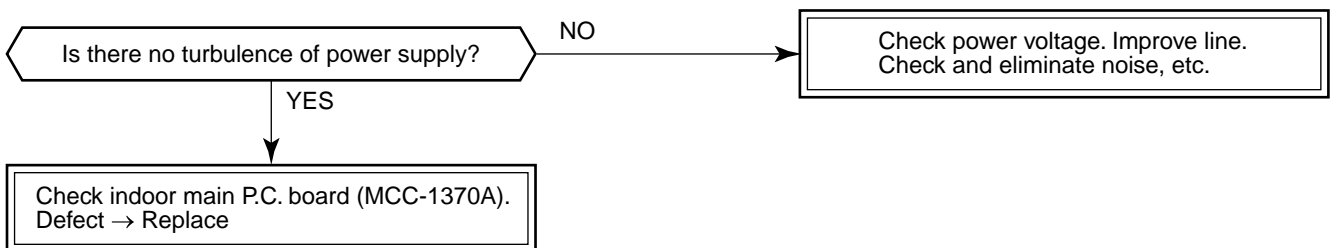

[14 error]

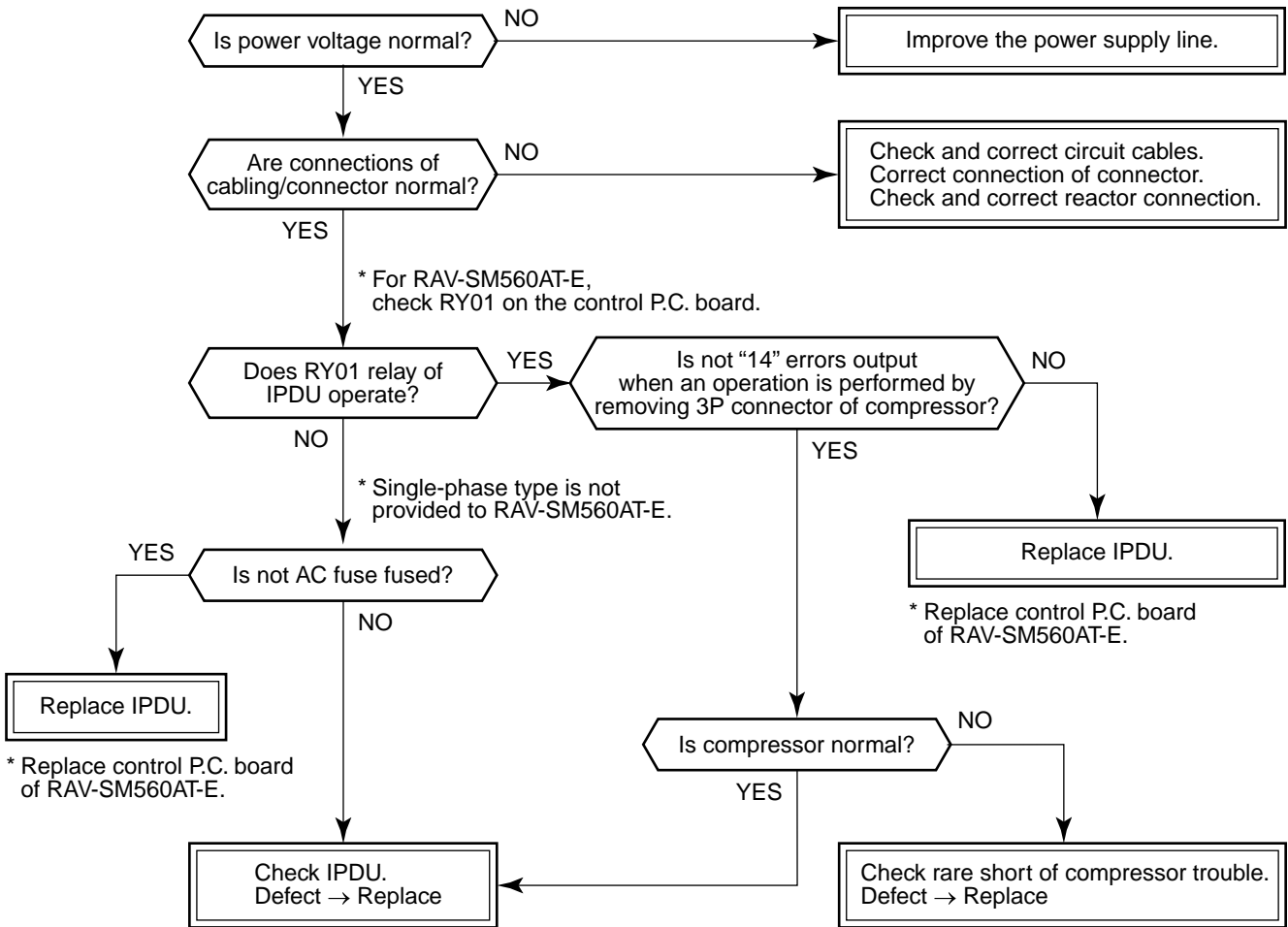

[16 error]

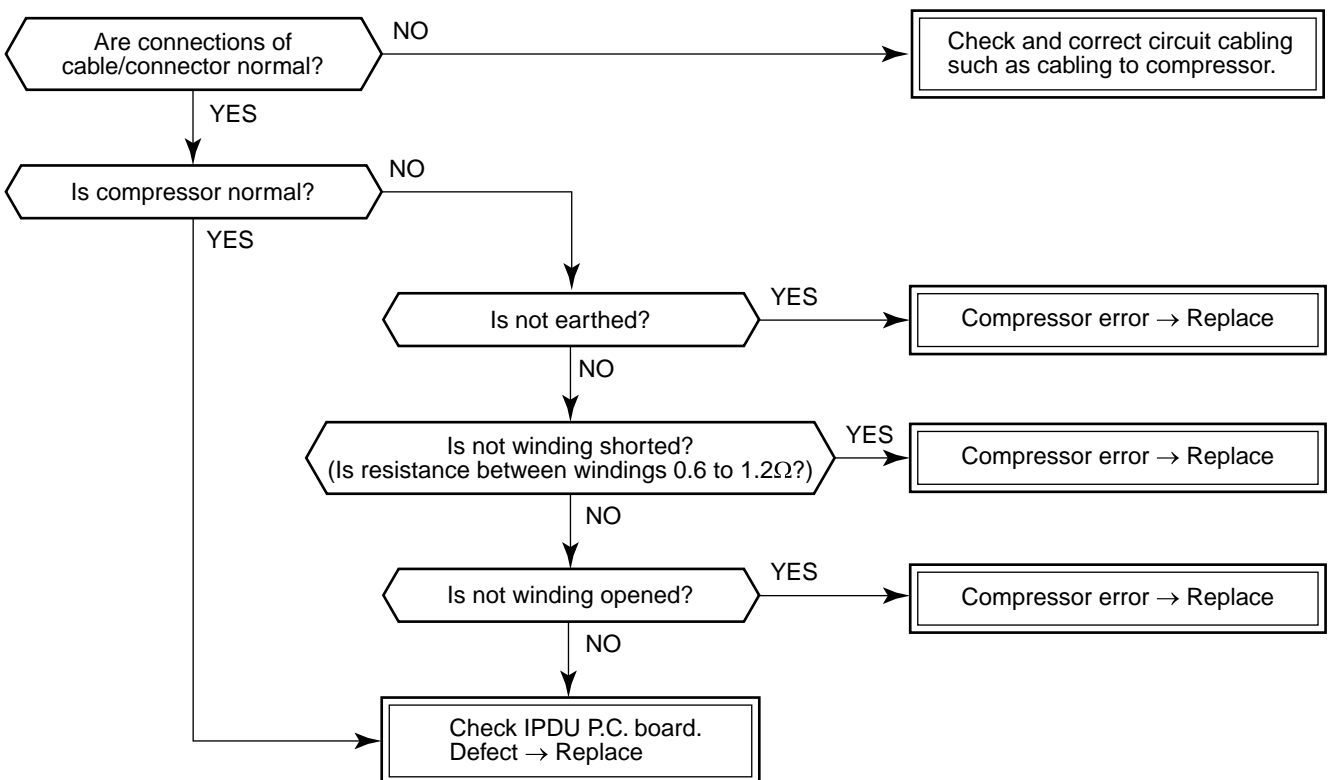

[18 error]

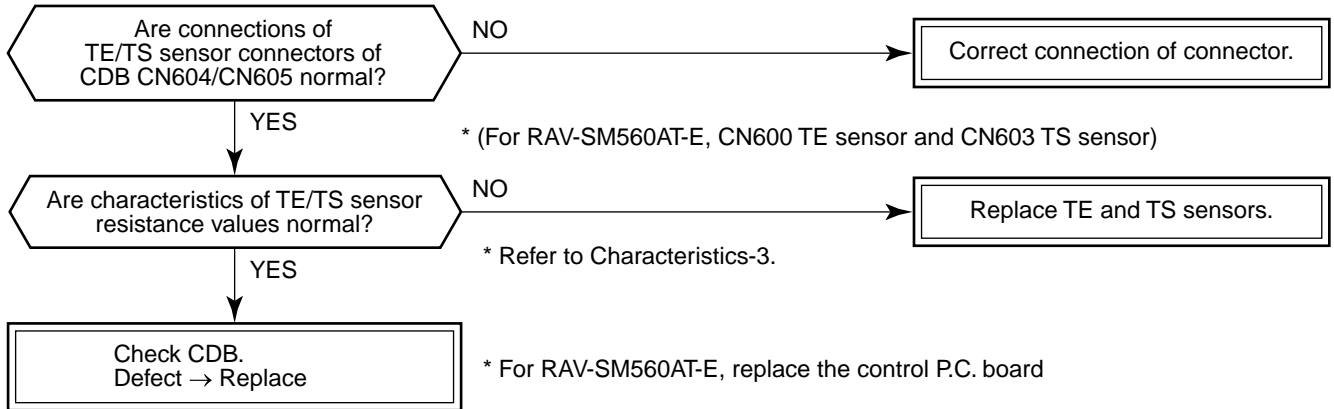

[19 error]

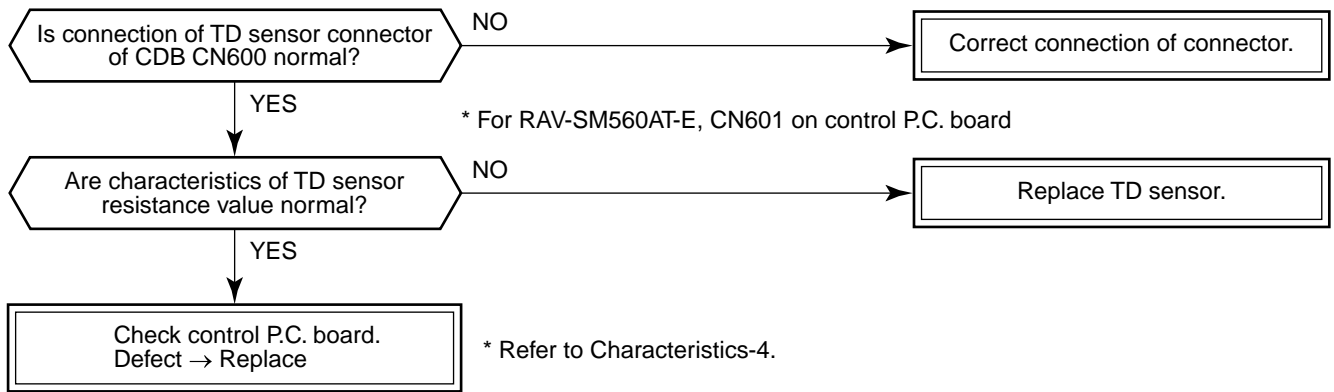

[1C error] * Except RAV-SM560AT-E

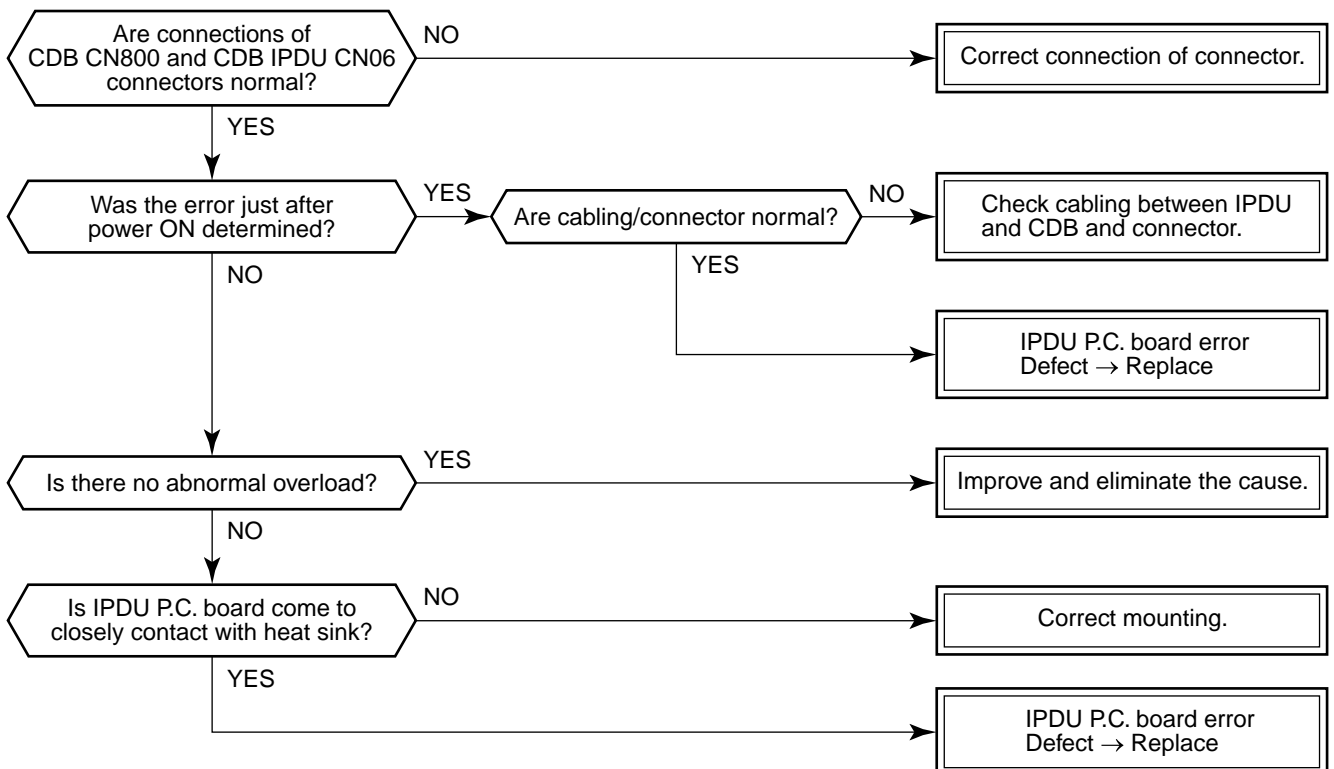

[1d error]

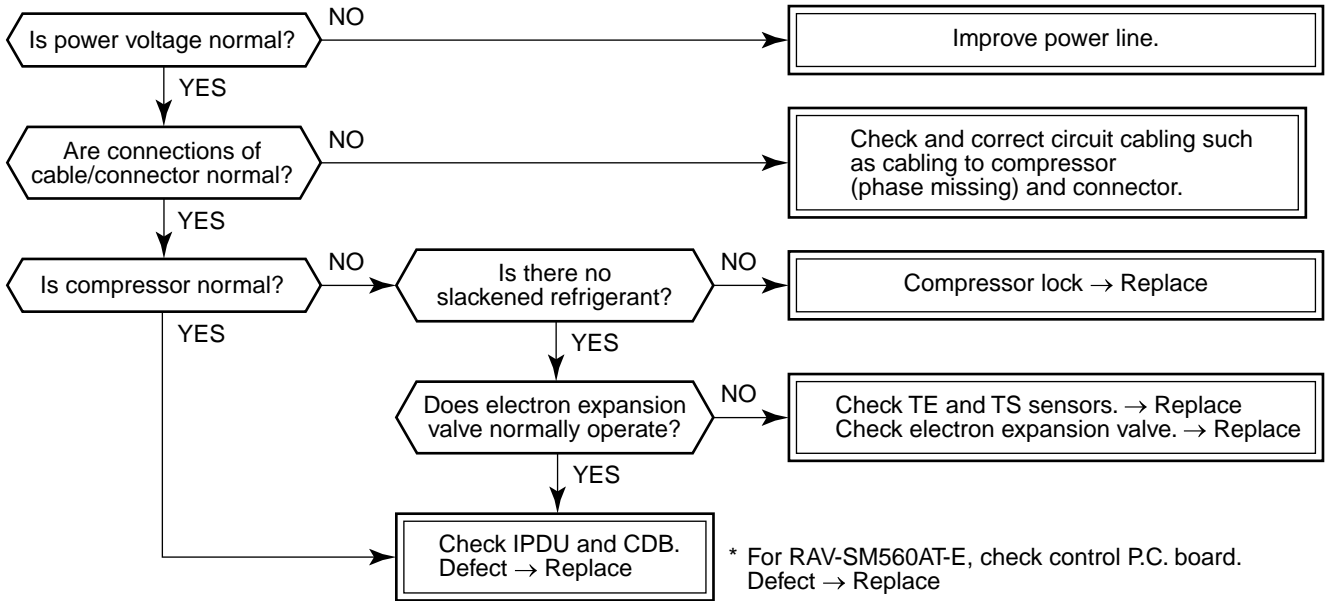

[1E error]

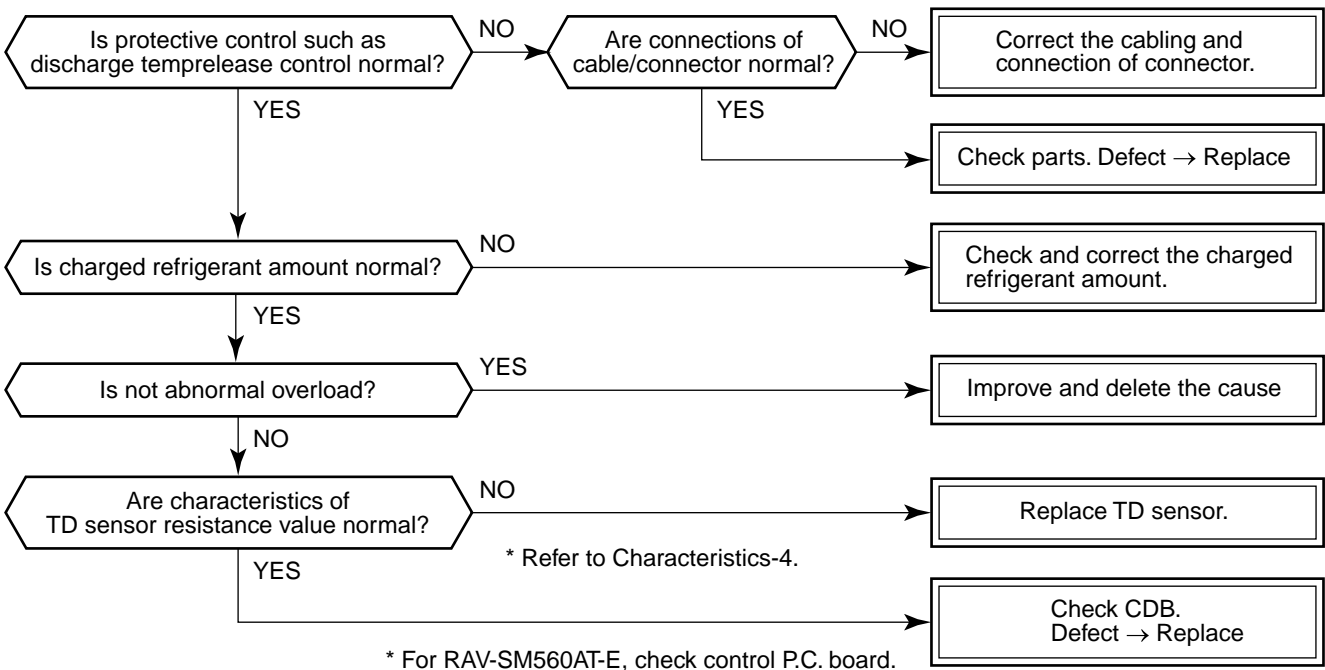

[1F error]

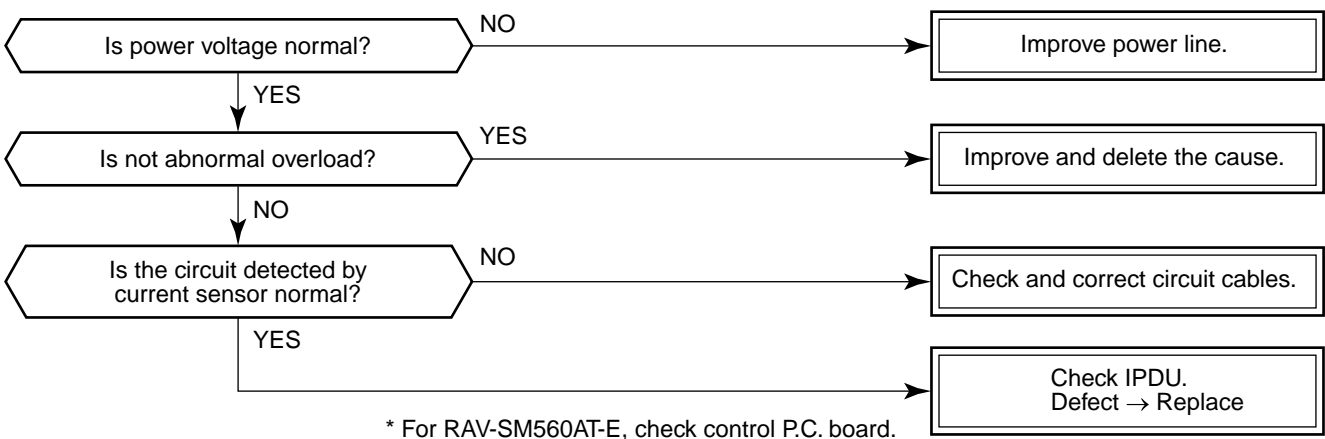

14-5. Simple Check Method for Main Parts

14-5-1. Indoor unit

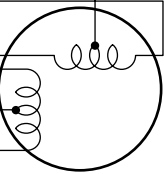
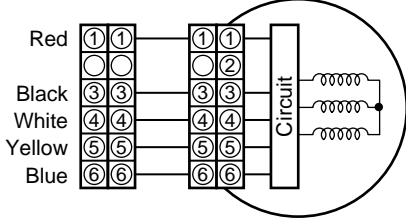
No.	Part name	Check procedure																									
1	Temperature sensor (Ta) Heat exchanger sensor (Tc) Heat exchanger sensor (Tcj)	Measure the resistance value with tester by removing the connector. (Normal temperature) <table border="1" data-bbox="564 409 1018 468" style="margin: 10px auto;"> <tr> <td>Normal value</td> <td>10 kΩ to 20 kΩ</td> </tr> </table> Refer to Characteristics table.	Normal value	10 kΩ to 20 kΩ																							
Normal value	10 kΩ to 20 kΩ																										
2	Louver motor MP35EA12	Measure the resistance value of each winding coil with tester. (Under normal temperature 25°C) <div style="display: flex; justify-content: space-around; align-items: center; margin: 10px 0;"> <table border="1" data-bbox="564 600 954 840" style="font-size: small;"> <tr><td>Brown</td><td>①</td><td>①</td></tr> <tr><td>Red</td><td>②</td><td>②</td></tr> <tr><td>Orange</td><td>③</td><td>③</td></tr> <tr><td>Yellow</td><td>④</td><td>④</td></tr> <tr><td>Pink</td><td>⑤</td><td>⑤</td></tr> <tr><td>Blue</td><td>⑥</td><td>⑥</td></tr> </table>  <table border="1" data-bbox="1027 577 1422 748" style="font-size: small;"> <thead> <tr> <th>Position</th> <th>Resistance value</th> </tr> </thead> <tbody> <tr> <td>Between 1 and 2</td> <td rowspan="4" style="text-align: center; vertical-align: middle;">130 ± 40Ω</td> </tr> <tr> <td>Between 1 and 3</td> </tr> <tr> <td>Between 1 and 4</td> </tr> <tr> <td>Between 1 and 5</td> </tr> </tbody> </table> </div>	Brown	①	①	Red	②	②	Orange	③	③	Yellow	④	④	Pink	⑤	⑤	Blue	⑥	⑥	Position	Resistance value	Between 1 and 2	130 ± 40Ω	Between 1 and 3	Between 1 and 4	Between 1 and 5
Brown	①	①																									
Red	②	②																									
Orange	③	③																									
Yellow	④	④																									
Pink	⑤	⑤																									
Blue	⑥	⑥																									
Position	Resistance value																										
Between 1 and 2	130 ± 40Ω																										
Between 1 and 3																											
Between 1 and 4																											
Between 1 and 5																											
3	Indoor fan motor (ICF-340-30-1)	Measure the resistance value of each winding coil with tester. If for P.C. board side, proceed to [11 error] of "Troubleshooting procedure for each check code". <table border="1" data-bbox="564 1008 1422 1229" style="margin: 10px auto; font-size: small;"> <thead> <tr> <th>Position</th> <th>Resistance value</th> </tr> </thead> <tbody> <tr> <td>Between ③ (Black) and ① (Red)</td> <td style="text-align: center;">∞ (MΩ)</td> </tr> <tr> <td>Between ③ (Black) and ④ (White)</td> <td style="text-align: center;">27 to 47 kΩ</td> </tr> <tr> <td>Between ③ (Black) and ⑤ (Yellow)</td> <td style="text-align: center;">140 to 280 kΩ</td> </tr> <tr> <td>Between ③ (Black) and ⑥ (Blue)</td> <td style="text-align: center;">∞ (MΩ)</td> </tr> </tbody> </table> <div style="text-align: center; margin: 10px 0;">  </div>	Position	Resistance value	Between ③ (Black) and ① (Red)	∞ (MΩ)	Between ③ (Black) and ④ (White)	27 to 47 kΩ	Between ③ (Black) and ⑤ (Yellow)	140 to 280 kΩ	Between ③ (Black) and ⑥ (Blue)	∞ (MΩ)															
Position	Resistance value																										
Between ③ (Black) and ① (Red)	∞ (MΩ)																										
Between ③ (Black) and ④ (White)	27 to 47 kΩ																										
Between ③ (Black) and ⑤ (Yellow)	140 to 280 kΩ																										
Between ③ (Black) and ⑥ (Blue)	∞ (MΩ)																										

Relational graph of temperature sensor resistance value and temperature

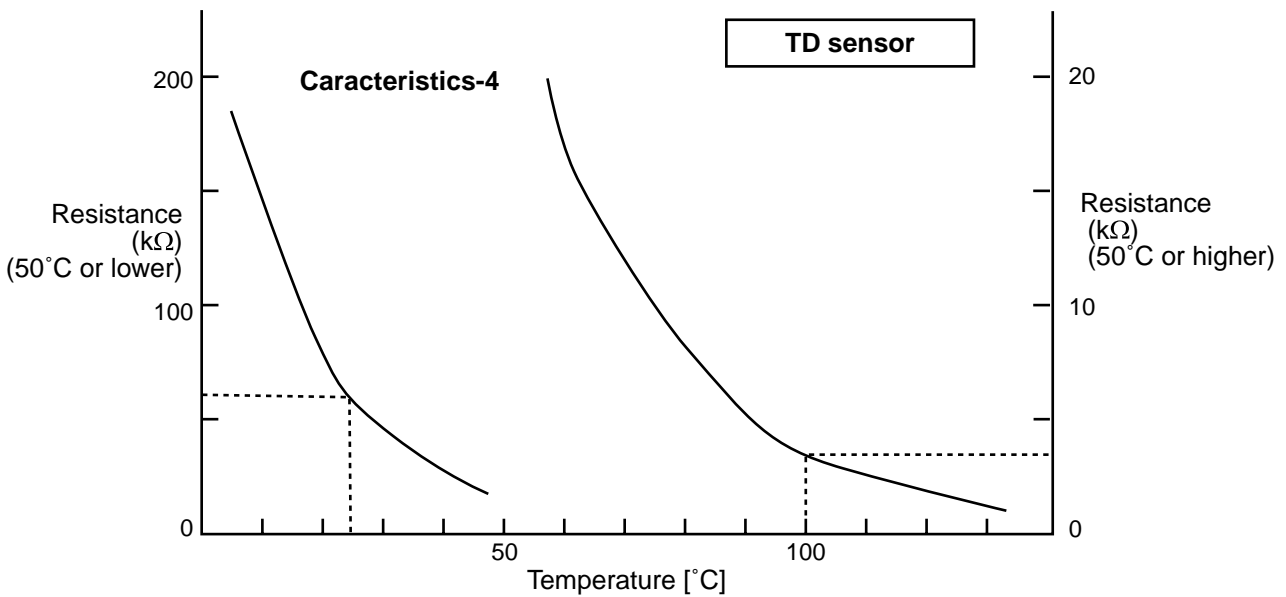
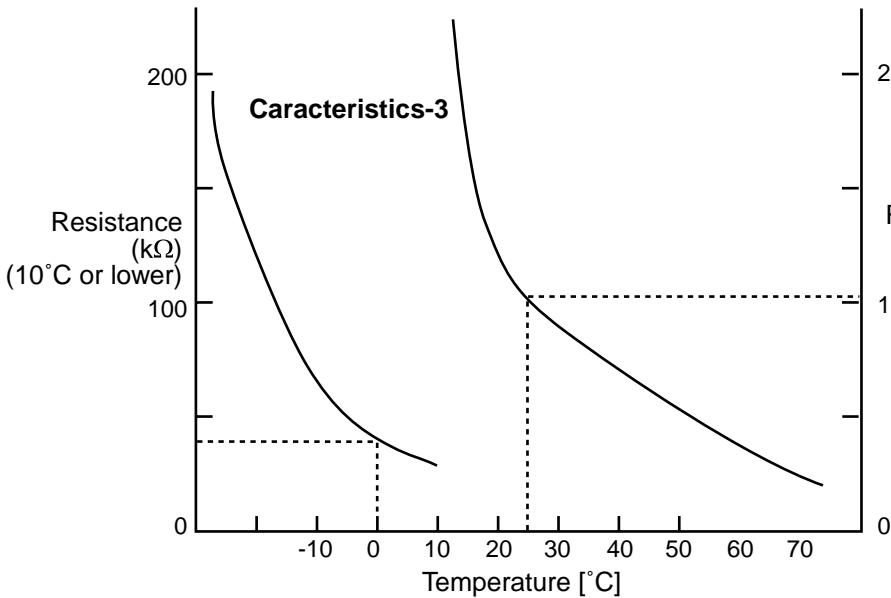
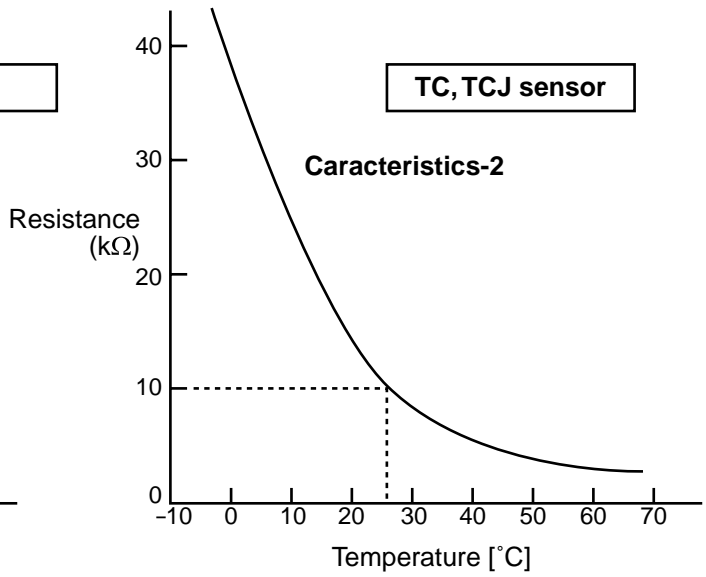
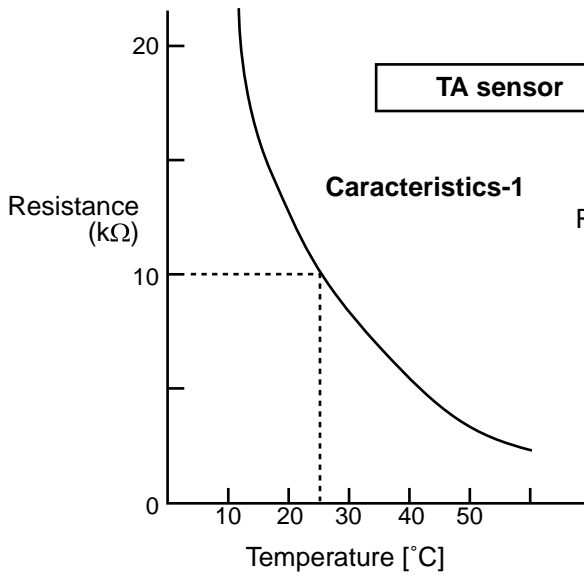

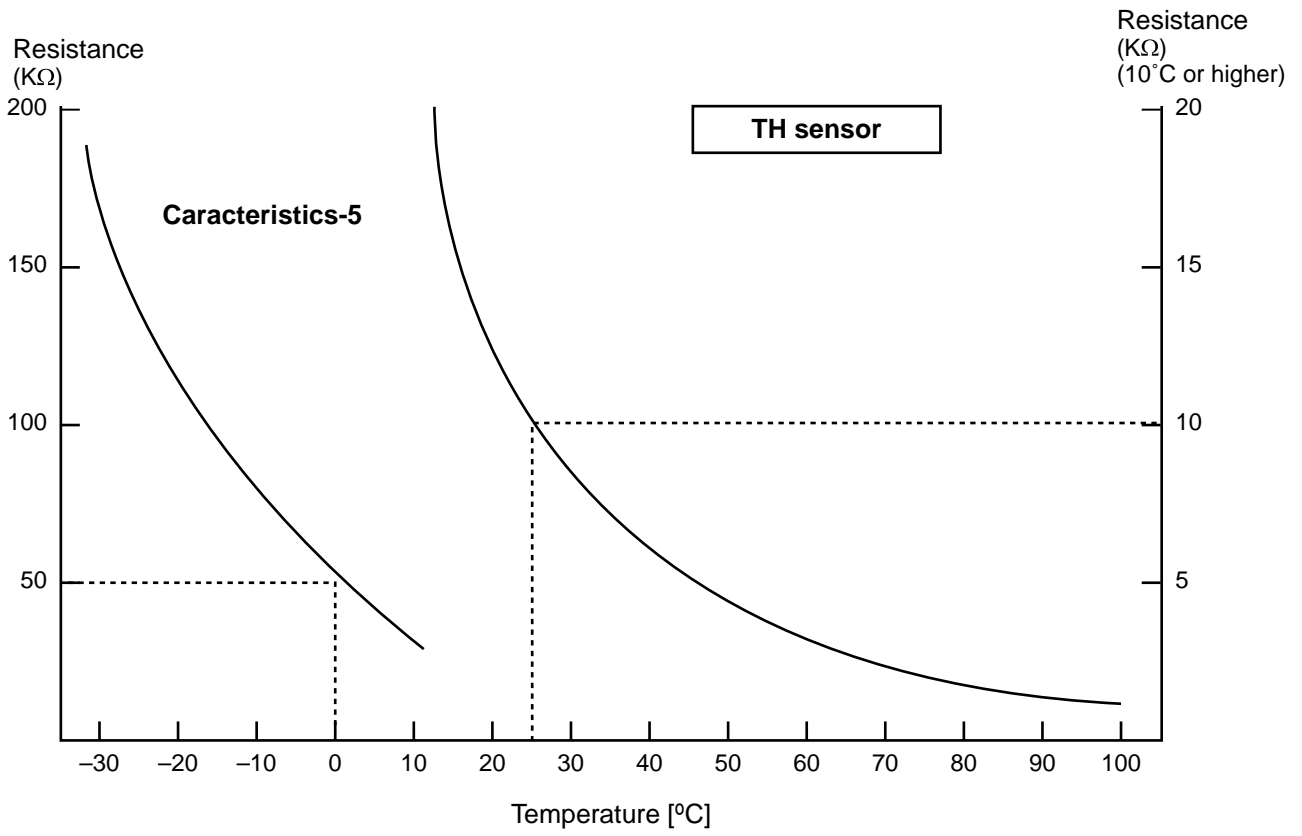



15. DETACHMENTS

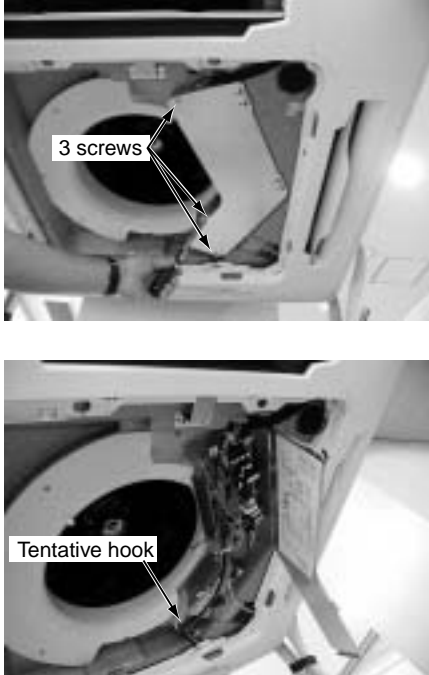

15-1. Indoor Unit

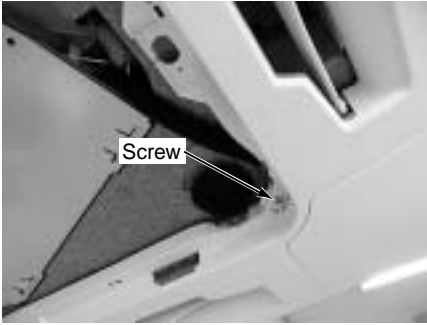

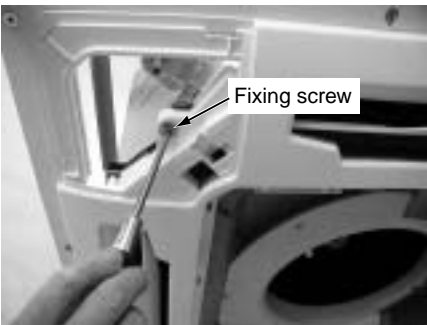
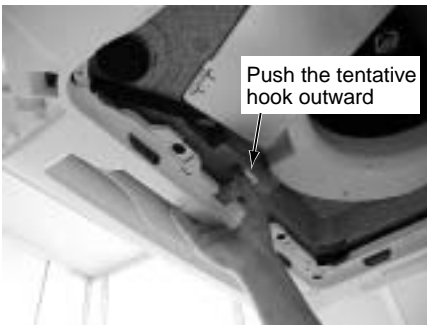
RAV-SM560UT-E, SM800UT-E

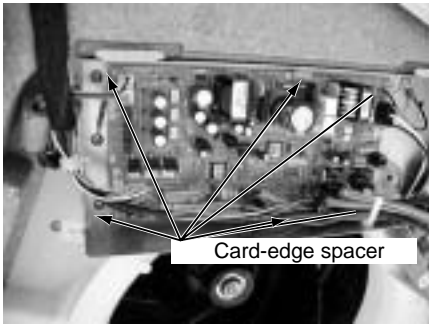

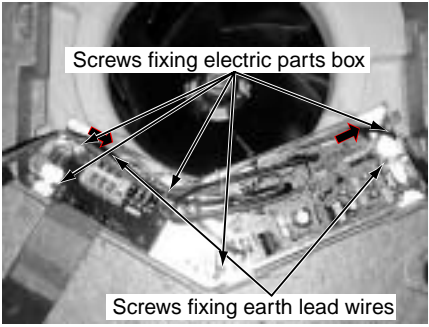
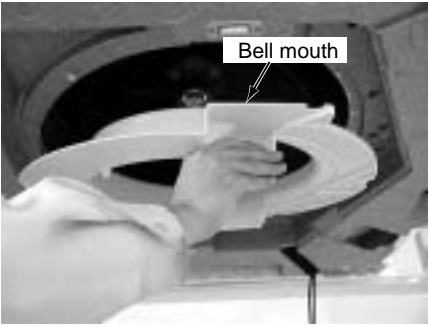
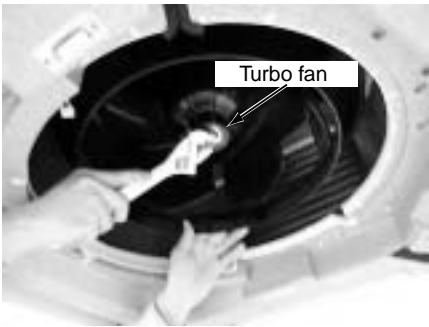
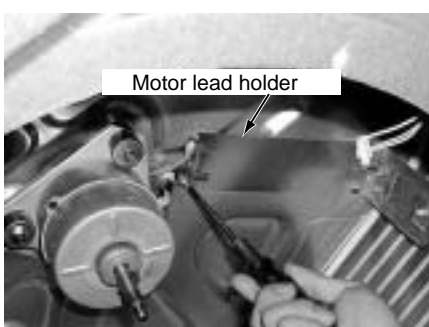
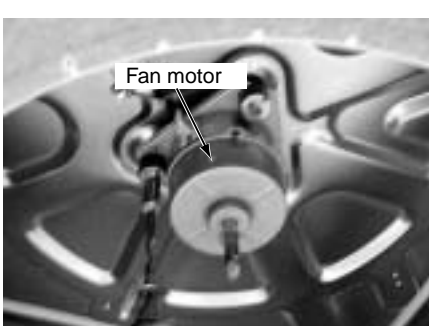
No.	Part name	Procedure	Remarks
①	Suction grille	<p style="text-align: center;">REQUIREMENT</p> <p>Never forget to put on the gloves at disassembling work, otherwise an injury will be caused.</p> <p>1. Detachment</p> <ol style="list-style-type: none"> 1) Stop operation of the air conditioner, and then turn off switch of the breaker. 2) Hang down the suction grille while sliding two knobs of the suction grille inward. 3) Remove a strap connecting the panel and the suction grille to remove the suction grille. <p>2. Attachment</p> <ol style="list-style-type: none"> 1) Hang the suction grille to the panel. 2) Attach the strap of the suction grille to the panel as before. 3) Close the suction grille, slide the knobs outward, and then fix it. 	
②	Electric parts cover	<p>1. Detachment</p> <ol style="list-style-type: none"> 1) Perform work of item 1. of ①. 2) Remove screws fixing the electric parts cover. (Ø4 x 10, 3 pcs.) 3) Remove the electric parts cover from the tentative hook, and then open the cover. <p>2. Attachment</p> <ol style="list-style-type: none"> 1) Close the electric parts cover and hang the cover hole to the tentative hook. 2) Tighten the fixing screws. (Ø4 x 10, 3 pcs.) 	

No.	Part name	Procedure	Remarks
③	Adjust corner cap	<p>1. Detachment</p> <ol style="list-style-type: none"> 1) Perform work of item 1. of ①. 2) Remove screws at 4 corners of the suction port. (Ø4 x 10, 4 pcs.) 3) Push the knob outward and remove the adjust corner cap by sliding it. <p>2. Attachment</p> <ol style="list-style-type: none"> 1) Mount the adjust corner cap by sliding it inward. 2) Tighten screws at 4 corners of the suction port. (Ø4 x 10, 4 pcs.) 	 <p>Screw</p>  <p>Push outward</p>
④	Ceiling panel	<p>1. Detachment</p> <ol style="list-style-type: none"> 1) Perform works of items 1 of ①, 1 of ② and 1 of ③. 2) Remove the flap connector (CN33, White, 5P) connected to the control P.C. board, and then remove the lead wire from the clamp. <div style="border: 1px solid black; padding: 5px; margin: 10px 0;"> <p>NOTE : Remove the connector by releasing locking of the housing.</p> </div> <ol style="list-style-type: none"> 3) Remove screws fixing the ceiling panel. (M5, 4 pcs.) 4) Push the tentative hook outward to remove the ceiling panel. <p>2. Attachment</p> <ol style="list-style-type: none"> 1) Hang the tentative hook of the main body drain pan to the tentative hook of the ceiling panel. <div style="border: 1px solid black; padding: 5px; margin: 10px 0;"> <p>NOTE : A panel has directional property, so mount a panel with attention to the marks.</p> </div> <ol style="list-style-type: none"> 2) Tighten fixing screws. (M5, 4 pcs.) 3) Connect flap connector of the ceiling panel to connector (CN33, White, 5P) on the control P.C. board. 	 <p>Remove the flap connector</p>  <p>Fixing screw</p>  <p>Push the tentative hook outward</p>

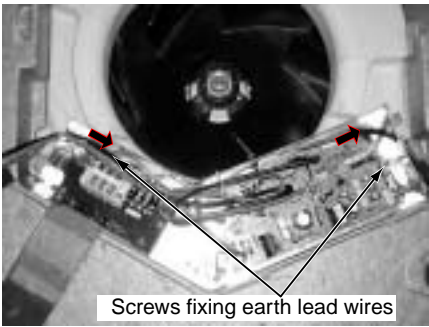
No.	Part name	Procedure	Remarks
⑤	Control P.C. board	<p>1. Detachment</p> <p>1) Perform works of items 1 of ① and 1 of ②.</p> <p>2) Remove connectors which are connected from the control P.C. board to other parts.</p> <p>CN33 : Flap motor (5P: White) CN34 : Float switch (3P: Red) CN41 : Terminal block of remote controller (3P: Blue) CN68 : Drain pump (3P: Blue) CN67 : Terminal block of power supply (5P: Black) CN101 : TC sensor (2P: Black) CN102 : TCJ sensor (2P: Red) CN104 : Room temperature sensor (2P: Yellow) CN333 : Power supply of fan motor (5P: White) CN334 : Position detection of fan motor (5P: White)</p> <div data-bbox="411 949 948 1079" style="border: 1px solid black; padding: 5px; margin: 10px 0;"> <p>NOTE : Remove the connector by releasing locking of the housing.</p> </div> <p>3) Unlock locking of the card-edge spacer at 6 positions to remove the control P.C. board.</p> <p>2. Attachment</p> <p>1) Fix the control P.C. board to the card-edge spacer at 6 positions.</p> <p>2) Connect the connectors removed in item 1 to the original positions.</p>	

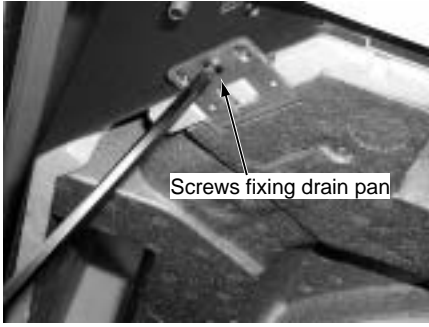
No.	Part name	Procedure	Remarks
⑥	Fan motor	<p>1. Detachment</p> <ol style="list-style-type: none"> 1) Perform works of items 1 of ① and 1 of ②. 2) Remove clamps of the lead wires connected to the following connectors of the control P.C. board. CN33 : Flap motor (5P: White) CN34 : Float switch (3P: Red) CN68 : Drain pump (3P: Blue) CN101 : TC sensor (2P: Black) CN102 : TCJ sensor (2P: Red) CN333 : Power supply of fan motor (5P: White) CN334 : Position detection of fan motor (5P: White) <div style="border: 1px solid black; padding: 5px; margin: 10px 0;"> <p>NOTE : Remove the connector by releasing locking of the housing.</p> </div> <ol style="list-style-type: none"> 3) Remove screws fixing earth lead wire in the electric parts box. (Ø4 x 6, 2 pcs.) 4) Remove indoor/outdoor inter-unit cable and remote controller cable of the terminal block. 5) Remove screws fixing the electric parts box. (Ø4 x 10, 5 pcs.) 6) Remove screws fixing the bell mouth. (Ø4 x 10, 6 pcs.) 7) Remove nuts fixing the turbo fan. (M6, 1 pc.) 8) Remove screws fixing holder of the motor lead wires to remove the motor lead wires from the clamp. (Ø4 x 8, 3 pcs.) 9) Remove nuts fixing the fan motor to remove it. <p>2. Attachment</p> <ol style="list-style-type: none"> 1) Fix the parts, fan motor, holder of the motor lead, turbo fan, bell mouth, and electric parts box successively to their original positions. <div style="border: 1px solid black; padding: 5px; margin: 10px 0;"> <p>NOTE 1 : When fixing the turbo fan, be sure to match the fan boss with D-cut of the motor shaft.</p> <p>NOTE 2 : Fix the turbo fan with torque wrench $5.9 \pm 0.6\text{Nm}$.</p> </div> <ol style="list-style-type: none"> 2) Connect connectors, earth lead wire, indoor/outdoor inter-unit cable, and remote controller cable which have been disconnected in the above item 1 as before. 	 <p>Screws fixing electric parts box</p>  <p>Screws fixing earth lead wires</p>  <p>Bell mouth</p>  <p>Turbo fan</p>  <p>Motor lead holder</p>  <p>Fan motor</p>

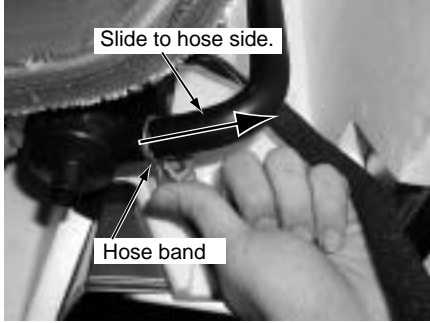
No.	Part name	Procedure	Remarks
⑦	Drain pan	<p>1. Detachment</p> <ol style="list-style-type: none"> 1) Perform works of items 1 of ①, 1 of ②, 1 of ③ and 1 of ④. 2) Remove clamps of the lead wires connected to the following connectors of the control P.C. board. CN34 : Float switch (3P: Red) CN68 : Drain pump (3P: Blue) CN101 : TC sensor (2P: Black) CN102 : TCJ sensor (2P: Red) CN333 : Power supply of fan motor (5P: White) CN334 : Position detection of fan motor (5P: White) <div style="border: 1px solid black; padding: 5px; margin: 10px 0;"> <p>NOTE : Remove the connector by releasing locking of the housing.</p> </div> <ol style="list-style-type: none"> 3) Remove screws fixing earth lead wire in the electric parts box. (Ø4 x 6, 2 pcs.) 4) Remove indoor/outdoor inter-unit cable and remote controller cable of the terminal block. 5) Remove screws fixing the electric parts box. (Ø4 x 10, 5 pcs.) 6) Remove screws fixing the bell mouth. (Ø4 x 10, 6 pcs.) 7) Remove the drain cap, and drain water accumulated in the drain pan. <div style="border: 1px solid black; padding: 5px; margin: 10px 0;"> <p>NOTE 1 : When removing the drain cap, be sure to prepare a bucket to catch the drained water.</p> <p>NOTE 2 : Thermal insulator is adhered to the drain cap. Be careful not to peel off the insulator. If the insulator has been peeled, adhere it with double-face tape, etc. as before.</p> </div> <ol style="list-style-type: none"> 8) Remove screws fixing the drain pan. (Ø4 x 8, 4 pcs.) <p>2. Attachment</p> <ol style="list-style-type: none"> 1) Fix the parts, drain cap, drain pan, bell mouth, and electric parts box successively to their original positions. 2) Connect connectors, earth lead wire, indoor/outdoor inter-unit cable, and remote controller cable which have been disconnected in the above item 1 as before. 	 <p>Screws fixing earth lead wires</p>  <p>Drain cap</p>  <p>Screws fixing drain pan</p>

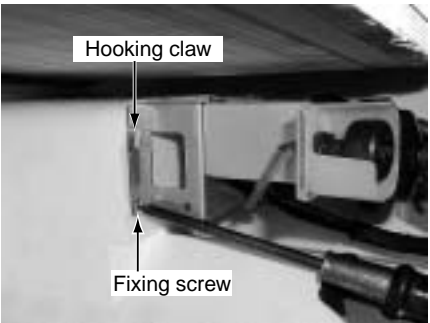
No.	Part name	Procedure	Remarks
⑧	Drain pump assembly	<p>1. Detachment</p> <ol style="list-style-type: none"> 1) Perform works of items 1 of ①, 1 of ②, 1 of ③, 1 of ④ and 1 of ⑦. 2) Picking the hose band, slide it from pump connecting part to remove the drain hose. 3) Remove screw fixing the drain pump assembly, slide hooking claws of the drain pump assembly and the main body (1 position), and then remove the assembly. (Ø4 x 8, 3 pcs.) <p>3. Attachment</p> <ol style="list-style-type: none"> 1) Fix the drain pump assembly as before. <div style="border: 1px solid black; padding: 5px; margin: 5px 0;"> <p>NOTE : The drain pump is fixed with a hook and 3 screws. In screwing, be sure that screws do not to run on hooking claw at the main body side.</p> </div> <ol style="list-style-type: none"> 2) Attach the drain hose and hose band as before. <div style="border: 1px solid black; padding: 5px; margin: 5px 0;"> <p>NOTE : Insert the drain hose up to the end of pump connecting part, and bind the white mark position of the hose with band.</p> </div>	  

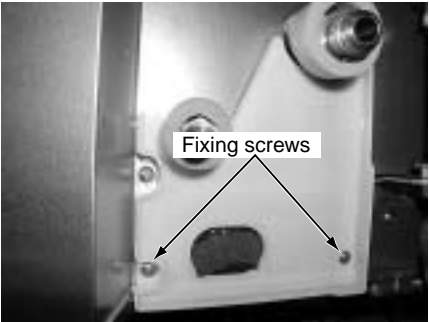
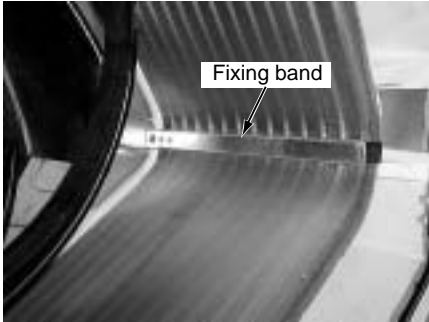
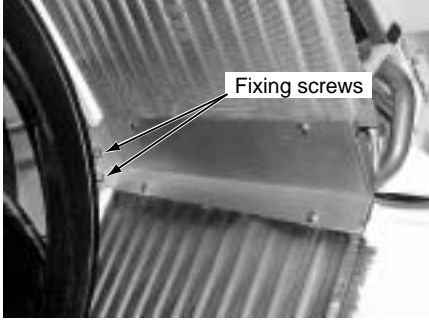
No.	Part name	Procedure	Remarks
⑨	Heat exchanger	<p>1. Detachment</p> <ol style="list-style-type: none"> 1) Recover refrigerant gas. 2) Remove refrigerant pipe at the indoor unit side. 3) Perform works of items 1 of ①, 1 of ②, 1 of ③, 1 of ④ and 1 of ⑦. 4) Remove screws fixing the pipe cover. (Ø4 x 8, 2 pcs.) 5) Remove the heat exchanger by removing fixing band and fixing screws while holding the heat exchanger. (Ø4 x 8, 3 pcs.) <p>2. Attachment</p> <ol style="list-style-type: none"> 1) Fix the parts, heat exchanger, fixing band, pipe cover, drain cap, drain pan, bell mouth, and electric parts box successively to their original positions. 2) Connect connectors, earth lead wire, indoor/outdoor inter-unit cable, and remote controller cable which have been disconnected in the above item 1 as before. 3) Connect the refrigerant pipe as before, and then perform vacuuming. 	  

15-2. Replacement of Distributor Assembly

RAV-SM560UT-E

1. Cutting of Capillary Tube

A capillary tube (023) : Inner diameter 2mm, Length 1000mm) is brazed to a distributor assembly. Cut and divide the tube to each length as shown below.

Ref No.	No. of capillary tubes	Cutting
023	4	200 mm : 2 pcs. 400 mm : 2 pcs.

[Cutting]

Plane circumference of the capillary tube with triangle file, etc., and then break off it.

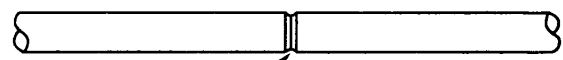

NOTE) Break off the capillary tube so that inner diameter is not deformed

15±5



2. Attachment of joint pipe

Insert the attached joint pipe into the end of the capillary tube up to 15mm, and braze it.

Form the capillary tube as same as that in the distributor assembly before replacement.

3. Brazing to indoor heat exchanger

Attach the capillary tube processed in items 1 and 2 to the end of the pipe with brazing as shown below.

023

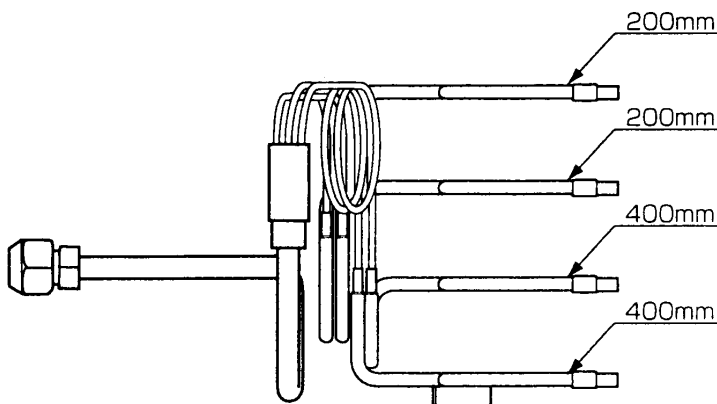

RAV-SM800UT-E

1. Cutting of Capillary Tube

A capillary tube (025) (026) : Inner diameter 2mm, Length 1000mm) is brazed to a distributor assembly. Cut and divide the tube to each length as shown below.

Ref No.	No. of capillary tubes	Cutting	
025	7	100 mm : 1 pc. 300 mm : 1 pc. 400 mm : 1 pc.	600 mm : 2 pcs. 700 mm : 1 pc. 800 mm : 1 pc.
026	10	100 mm : 2 pcs. 150 mm : 1 pc. 500 mm : 4 pcs.	600 mm : 2 pcs. 900 mm : 1 pc.

[Cutting]

Plane circumference of the capillary tube with triangle file, etc., and then break off it.

2. Attachment of joint pipe

Insert the attached joint pipe into the end of the capillary tube up to 15mm, and braze it.

Form the capillary tube as same as that in the distributor assembly before replacement.

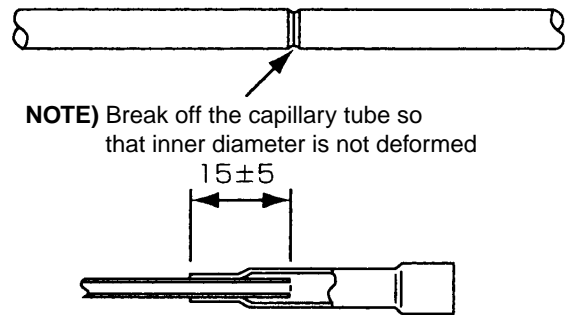

3. Brazing to indoor heat exchanger

Attach the capillary tube processed in items 1 and 2 to the end of the pipe with brazing as shown below.

025

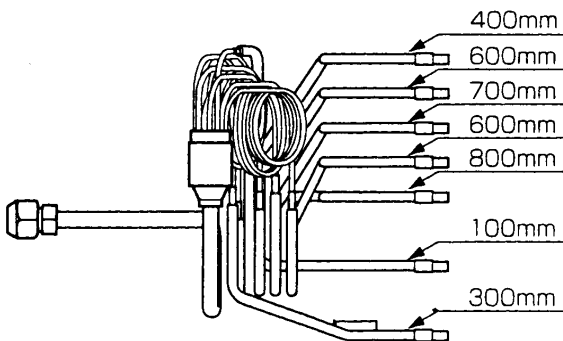

026

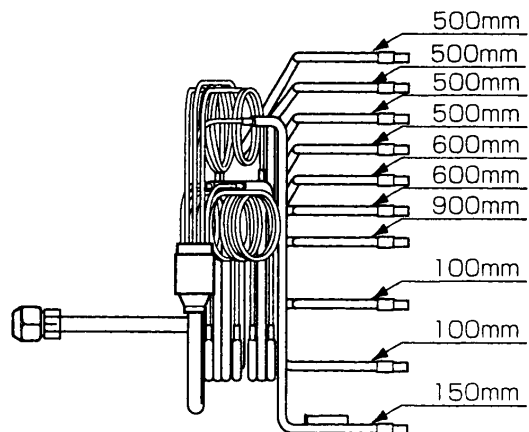

15-3. Replacement of Main Parts <Built-in type>

RAV-SM560BT-E, SM800BT-E

Be sure to turn off the power supply before disassembling work.

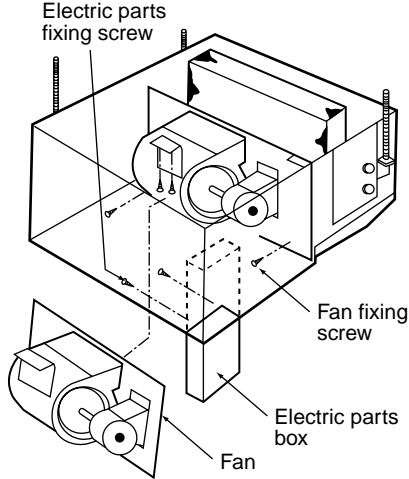
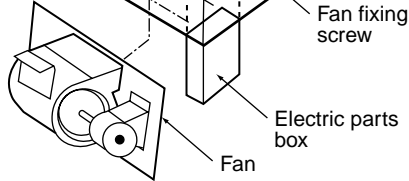
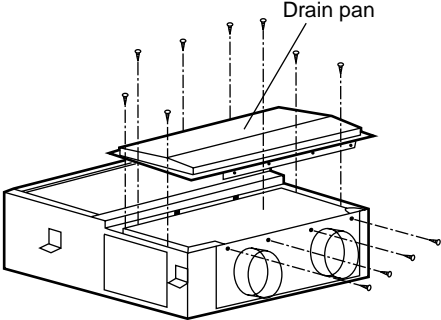
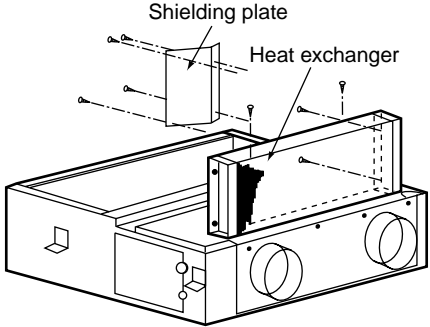
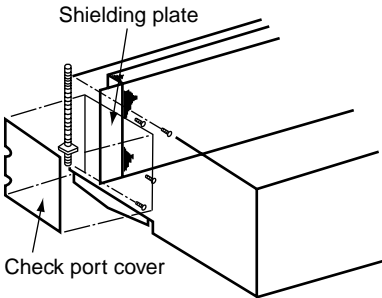
No.	Item	Procedure	
1	Electric parts box	1) Remove the electric parts box. (Supplement: Refer to How to remove the electric parts box.) In this time, remove connectors of TA sensor, TC sensor, and TCJ sensor, if necessary.)	
2	Fan	1) Remove connector of the fan motor. 2) Remove screws fixing the fan. (Screws at 4 positions) 3) Take off jointed portion of fan and cabinet, and then put down the fan. 4) Loosen set screw of the Silocco fan. 5) Remove set screw of the fan case. 6) Remove the fan motor mounting metal, and then replace the fan motor.	
3	Drain pan	1) Take down the indoor unit and then treat the drain pan on the floor. 2) Remove screws fixing the drain pan (12 positions) and then replace the drain pan.	
4	Heat exchanger	1) Take down the indoor unit and then treat the heat exchanger on the floor. 2) Remove screws fixing the drain pan (12 positions) and then remove the drain pan. 3) Remove the shielding plate. (Screws at 4 positions) 4) Remove screws (at 4 positions) fixing the heat exchanger, and then replace the heat exchanger.	
5	TC sensor (Sensor side)	1) Remove the check port cover. 2) Remove the shielding plate. (At 4 positions) 3) Pull out the sensors inserted into pipe of the heat exchanger.	

AID-P710BH, P800BH, P1120BH

Be sure to turn off the power supply before disassembling work.

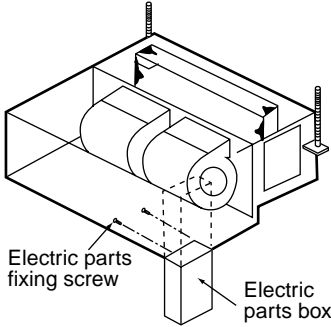
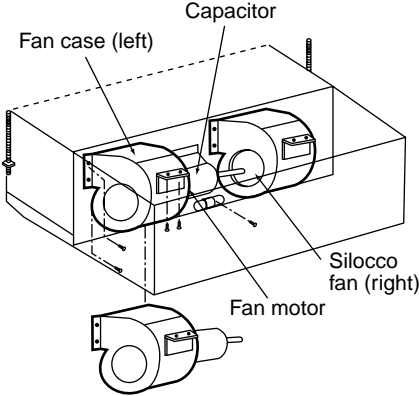
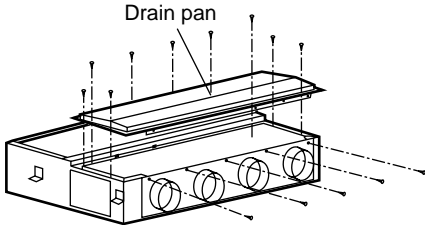
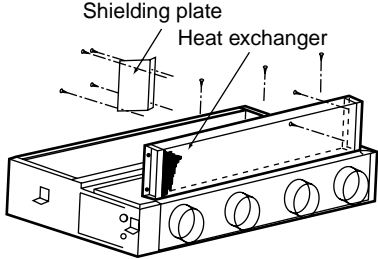
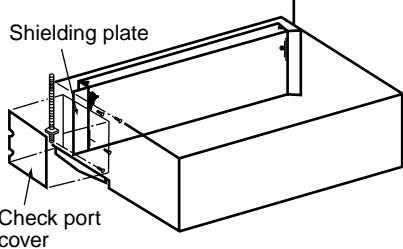
No.	Item	Procedure	
1	Electric parts box	1) Remove the electric parts box. (Supplement: Refer to How to remove the electric parts box.) In this time, remove connectors of TA sensor, TC sensor, and TCJ sensor, if necessary.)	
2	Fan	1) Remove connector of the fan motor. 2) Using a hexagonal wrench, loosen coupling fixing screws at 2 positions, and then slide the fan motor to reverse side. 3) Remove set screws (6 positions) of the fan case (left). 4) Remove fan motor mounting metal (screws at 2 positions) while holding the fan motor with hands. 5) Remove capacitor fixing screw (1 position). 6) Take down the fan motor and the fan case (left). 7) Loosen set screw of the Silocco fan. 8) Replace the fan motor.	
3	Drain pan	1) Take down the indoor unit and then treat the drain pan on the floor. 2) Remove screws fixing the drain pan and then replace the drain pan.	
4	Heat exchanger	1) Take down the indoor unit and then treat the heat exchanger on the floor. 2) Remove screws fixing the drain pan and then remove the drain pan. 3) Remove the shielding plate. (Screws at 4 positions) 4) Remove screws (at 5 positions) fixing the heat exchanger, and then replace the heat exchanger.	
5	TC sensor (Sensor side)	1) Remove the check port cover. 2) Remove the shielding plate. (At 4 positions) 3) Pull out the sensors inserted into pipe of the heat exchanger.	

[SUPPLEMENT] How to remove the electric parts box

Electric parts box

The electric parts box is fixed to the indoor unit with claws at the rear side. Lift up it once and pull toward you. Then claws come off.

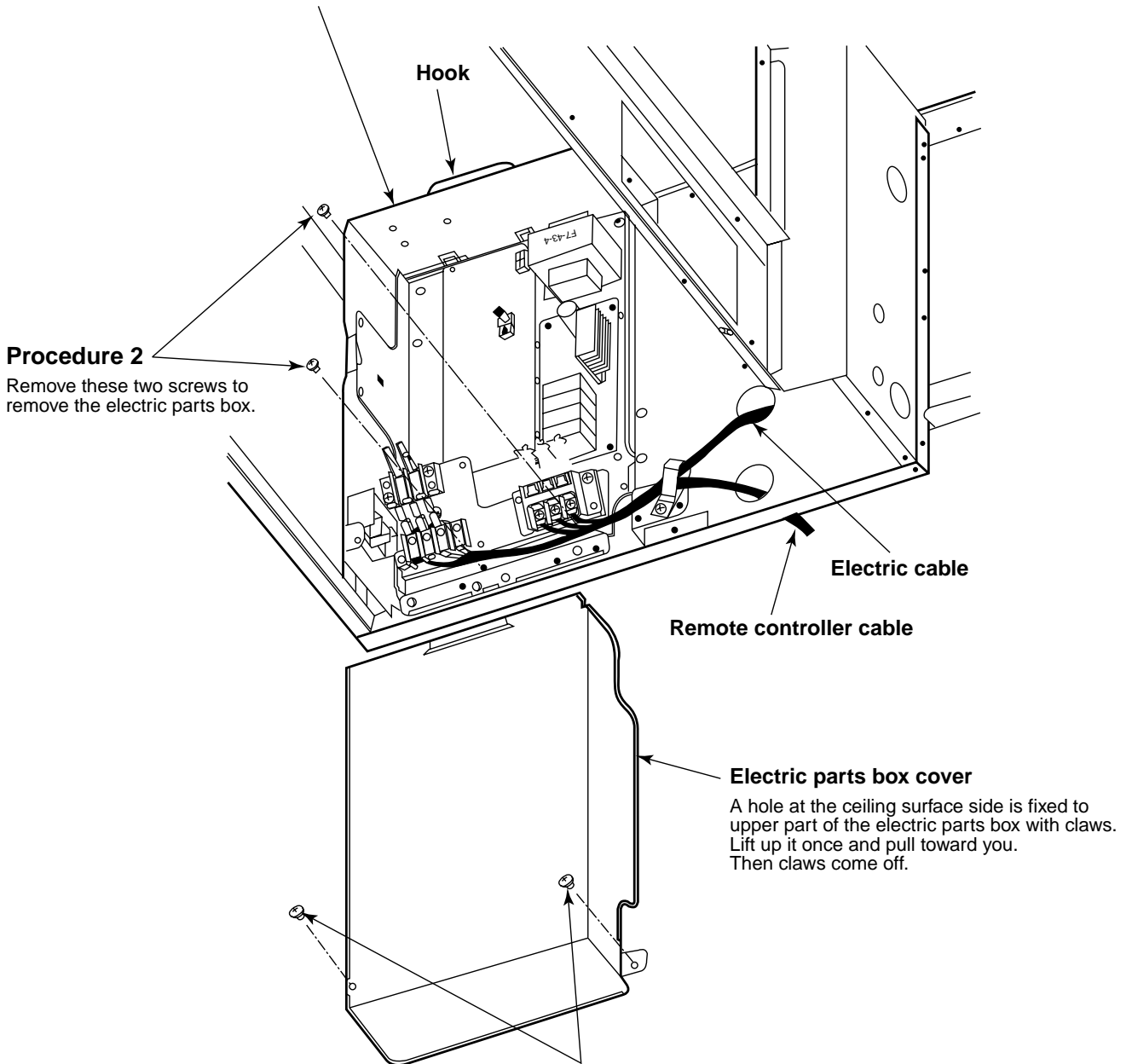

Procedure 2
Remove these two screws to remove the electric parts box.

Electric parts box cover
A hole at the ceiling surface side is fixed to upper part of the electric parts box with claws. Lift up it once and pull toward you. Then claws come off.

Procedure 1
Remove these two screws to remove the electric parts box cover.

15-4. Replacements of Main Parts <Hi-Wall type>

15-4-1. Indoor Unit

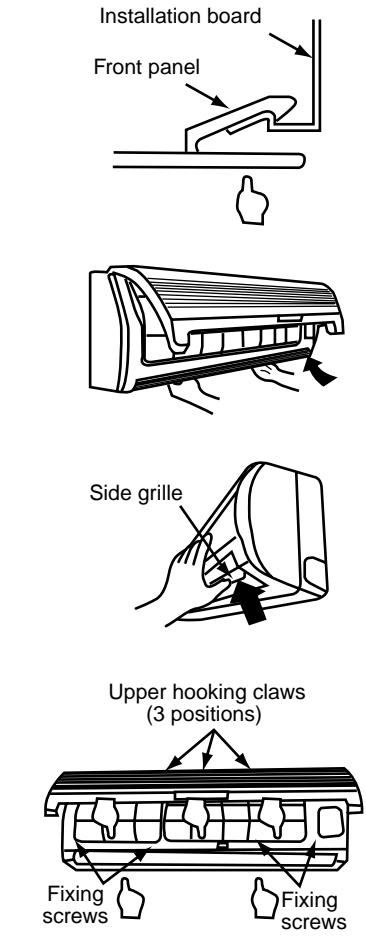
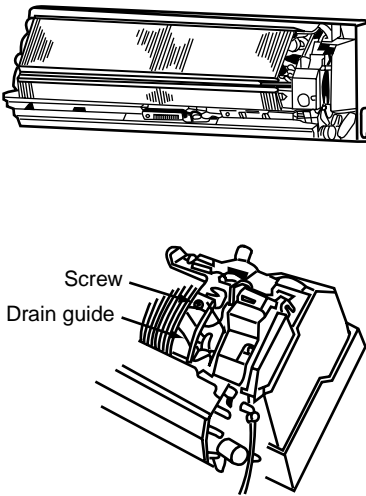
No.	Part name	Procedure	Remarks
①	Front panel	<ol style="list-style-type: none"> 1) Stop operation of the air conditioner, and turn off the power supply. 2) Push "PUSH" part at the lower side of the front panel, and then take off claws of the front panel from the installation board. 3) Open the suction grille and take off the front panel fixing screws (4 pcs.). 4) After turning the side grille as shown in the right figure, perform the following works. 5) Push the electric parts box with right thumb while pulling both sides of the front panel toward you. <p><Attachment of front panel></p> <ol style="list-style-type: none"> 1) Turn the side grille as shown in the right figure. 2) Push 3 positions at center of the discharge port and 2 positions at lower center of the discharge port, and then hook the hooking claws (3 positions) at upper surface of the front panel to the rear board. 3) Tighten 4 screws. <ul style="list-style-type: none"> • Insufficient hooking or pushing may cause falling of dewdrop or discomforting noise. <p>When removing the front panel without turning the side grille, the front panel may be broken.</p> 	 <p>Installation board</p> <p>Front panel</p> <p>Side grille</p> <p>Upper hooking claws (3 positions)</p> <p>Fixing screws</p> <p>Fixing screws</p>
②	Electric parts box assembly	<ol style="list-style-type: none"> 1) Perform work of item 1 of ①. 2) Remove the drain guide. 3) Take off screws for earth lead wire attached to the end plate of the heat exchanger. 4) Disconnect connectors for fan motor and louver motor from the microcomputer assembly. 5) Remove the display unit at the center of the set from the main body. 	 <p>Screw</p> <p>Drain guide</p>

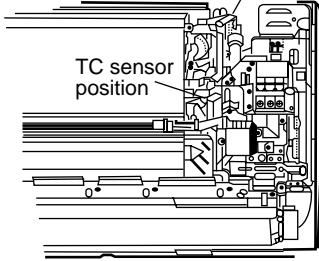
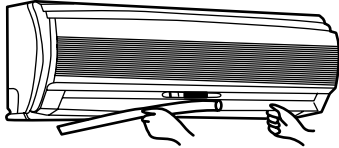
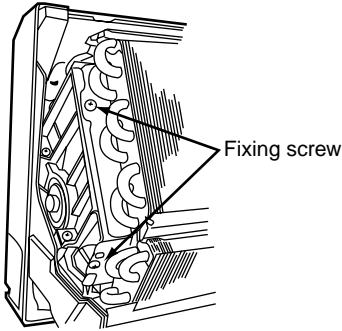
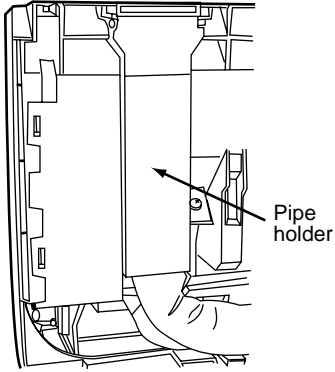
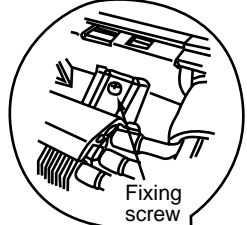
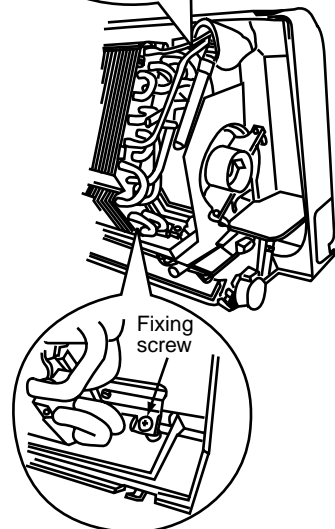
No.	Part name	Procedure	Remarks
②	Electric parts box assembly	<p>6) Take off fixing screw (1 position) of the electric parts base, and then pull out the electric parts base toward you.</p> <p>7) Pull out Tc sensor and Tcj sensor from sensor holder of the heat exchanger. After replacement of the parts, incorporate two sensors without mistake as shown in the right figure. (Tube is attached to Tcj sensor.)</p> <p>8) After replacement of the parts, set a trap so that water does not enter in the electric parts assembly. (Incomplete process for lead wires may cause water leak.)</p>	<p>Tcj sensor position (Tube is attached to Tcj sensor.)</p> 
③	Side grille	<p>1) Remove shaft of the side grille from the air conditioner body. (First remove the left shaft and then other shafts while sliding the side grille left and right.)</p>	
④	Heat exchanger	<p>1) Perform work of item ②.</p> <p>2) Remove pipe holder at rear side of the main body.</p> <p>3) Take off fixing screws (2 pcs.) at the left side of the end plate of the heat exchanger.</p>  <p>4) Take off two fixing screws of the heat exchanger holder (right), and then remove the heat exchanger holder (right).</p> <p>5) Take off fixing screw at lower right side of the heat exchanger.</p> <p>6) Remove the heat exchanger from the rear main body by lifting it upward.</p>	  

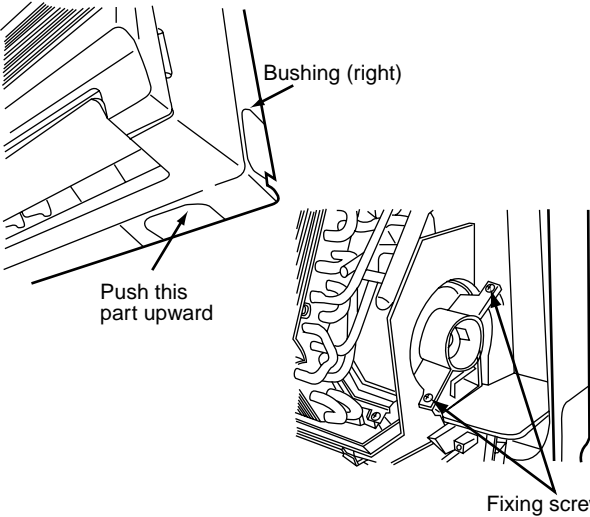
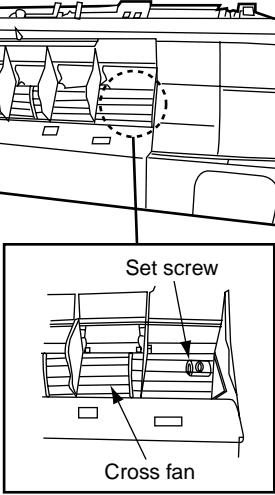
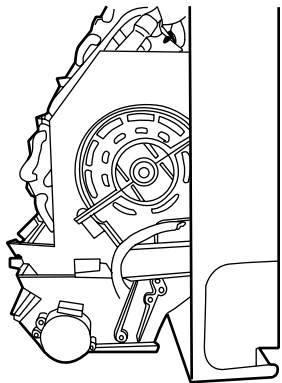
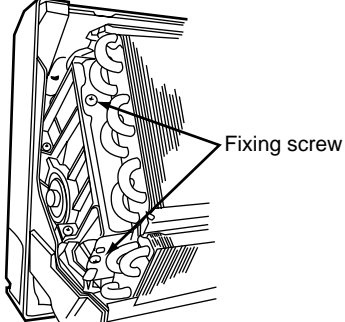
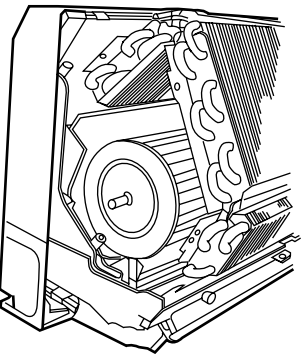
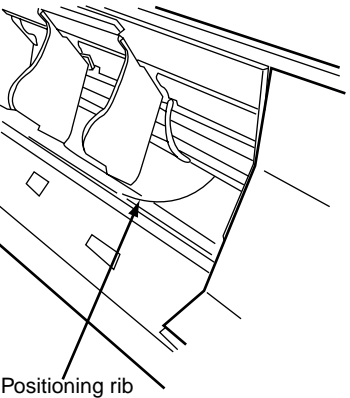
No.	Part name	Procedure	Remarks
⑤	Fan motor	<ol style="list-style-type: none"> 1) Perform work of item ①. 2) Perform work of item ③. 3) Loosen set screw of the cross flow fan from the discharge port. 4) Remove the bushing (right).  <ol style="list-style-type: none"> 5) Take off two fixing screws of the motor band (right). 6) Pull out the motor band (right) and the fan motor outward. <p>* Caution at reassembly</p> <ul style="list-style-type: none"> • Determine position of the fan motor so that connector of the fan motor enters in the positioning rib of the motor band (right). 	 
⑥	Cross flow fan	<ol style="list-style-type: none"> 1) Perform works of items ① and ③. 2) Loosen set screw of the cross flow fan from the discharge port. 3) Take off two fixing screws at the left side of the end plate of the heat exchanger, and then take off two fixing screws of the bearing base.  <ol style="list-style-type: none"> 4) Lift up slightly the left side of the heat exchanger to remove the bearing base. 5) Lift up the left side of the heat exchanger toward you to remove the cross flow fan. <p>* Caution at reassembly</p> <ul style="list-style-type: none"> • Mount the cross flow fan so that the left end of the first joint from right of the drift fan matches with the left end of the positioning rib of the rear main body. 	 

15-4.2. Replacement Procedure of Service Main P.C. Board

Replacement Procedure of Indoor Control P.C. Board

(AIK-PXXXH series, SIK-PXXXH series)

For this indoor control P.C. board **[AIK/SIK-P SERVICE]** corresponding to the common P.C. boards, follow to this replacement procedure when replacing P.C. board.

(When using SIK-PXXXH series, P.C. board name, parts layout, etc. of the presently mounted P.C. board differ from those of this service P.C. board. However there is no problem in the functions.)

Components

- Service P.C. board (MCC-1370A **[AIK/SIK-P SERVICE]**) : 1 unit
- Replacement Procedure of Indoor Control P.C. Board : These sheets
- Replacement Record of remote controller/indoor control P.C. board/outdoor control P.C. board : 1 sheet

Replacement Procedure

- 1** Remove the presently mounted P.C. board from the electric parts box.
(Be sure to send back the replaced P.C. board with Replacement Record attached separately.)
- 2** Set Dip SW and jumpers of the service P.C. board according to the following exchange correspondence table.

Model		<Reference>	AIK-PXXXH series		
			Service P.C. board Initial setup at shipment	AIK-P400H AIK-P450H AIK-P500H AIK-P560H	AIK-P630H
SW03	1	ON	Match setup with one of former P.C. board.		
	2	OFF			
J01			As it is :		
J07					
J09			Match setup with one of former P.C. board.		
J11					
J12					
J14			As it is :		
J15			As it is :	As it is :	Cut :
J16			As it is :	Cut :	As it is :
J17			As it is :	As it is :	As it is :
J19			As it is :		
J22			As it is :		
J24			Cut :		
J25			As it is :		
J36			As it is :		
J50			As it is :		
J53					
J54					
J55					

As it is : Setup of jumper of the service P.C. board is not changed.

- 3** Mount P.C. board according to **[Mounting]**.

[Mounting]

In case of AIK-PXXXH series

1. As same as P.C. board before replacement, attach a cable (Black) which is screwed to the electric parts box to CN240 without using a cable (Black) attached previously to CN240 of the service P.C. board.

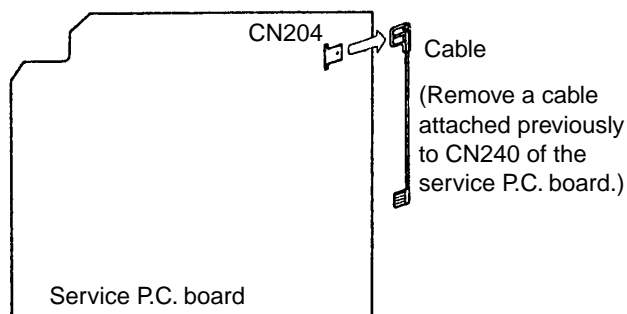

2. Attach other cables as same as P.C. board before replacement.

<(Reference) Explanation about functions of switches/jumpers>

- The following table shows the functions of the main switches and jumpers. Use as reference in miss-setup.

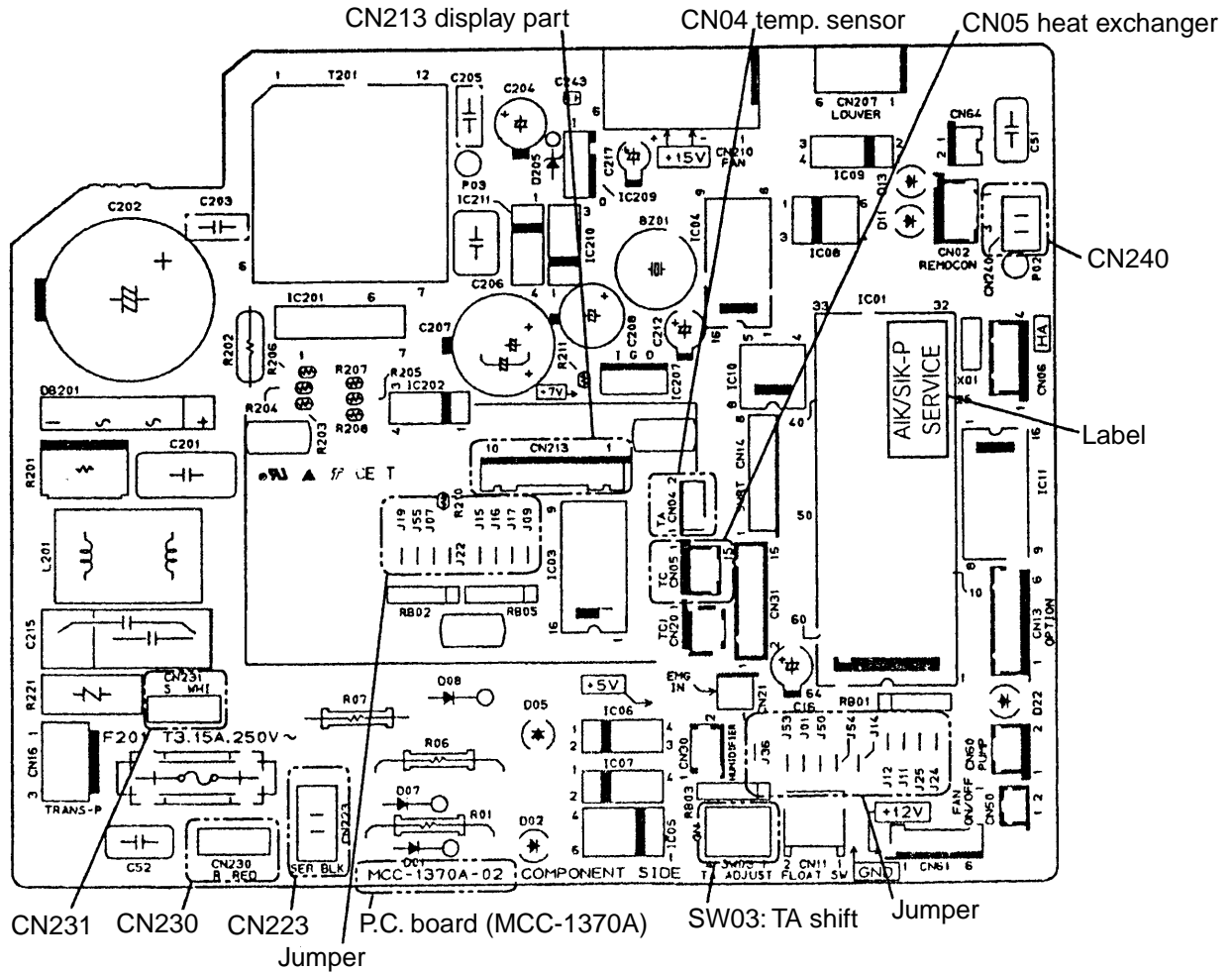

Part name		Function															
SW03	1	TA shift: Thermo-OFF point can be shifted in heating operation. <table border="1" style="margin-top: 10px;"> <thead> <tr> <th>Bit 1</th> <th>Bit 2</th> <th>Shift Q'ty</th> </tr> </thead> <tbody> <tr> <td>OFF</td> <td>OFF</td> <td>+ 6K</td> </tr> <tr> <td>OFF</td> <td>ON</td> <td>+ 4K</td> </tr> <tr> <td>ON</td> <td>OFF</td> <td>+ 2K (Setup at shipment)</td> </tr> <tr> <td>ON</td> <td>ON</td> <td>± 0K</td> </tr> </tbody> </table>	Bit 1	Bit 2	Shift Q'ty	OFF	OFF	+ 6K	OFF	ON	+ 4K	ON	OFF	+ 2K (Setup at shipment)	ON	ON	± 0K
	Bit 1		Bit 2	Shift Q'ty													
OFF	OFF		+ 6K														
OFF	ON		+ 4K														
ON	OFF		+ 2K (Setup at shipment)														
ON	ON	± 0K															
2																	
J09		Selection of hot start control temperature : The starting temperature of the fan can be raised in heating operation. <table border="1" style="margin-top: 10px;"> <thead> <tr> <th>J09</th> <th>Setup</th> </tr> </thead> <tbody> <tr> <td>Provided</td> <td>Normal (Setup at shipment)</td> </tr> <tr> <td>None</td> <td>Fan starting temp up (Approx. +4K)</td> </tr> </tbody> </table>	J09	Setup	Provided	Normal (Setup at shipment)	None	Fan starting temp up (Approx. +4K)									
J09	Setup																
Provided	Normal (Setup at shipment)																
None	Fan starting temp up (Approx. +4K)																
J11 J12		Setup of filter timer <table border="1" style="margin-top: 10px;"> <thead> <tr> <th>J11</th> <th>J12</th> <th>Setup</th> </tr> </thead> <tbody> <tr> <td>Provided</td> <td>Provided</td> <td>240 hours (Setup at shipment)</td> </tr> <tr> <td>None</td> <td>Provided</td> <td>2500 hours</td> </tr> <tr> <td>Provided</td> <td>None</td> <td>5000 hours</td> </tr> <tr> <td>None</td> <td>None</td> <td>Without filter timer</td> </tr> </tbody> </table>	J11	J12	Setup	Provided	Provided	240 hours (Setup at shipment)	None	Provided	2500 hours	Provided	None	5000 hours	None	None	Without filter timer
J11	J12	Setup															
Provided	Provided	240 hours (Setup at shipment)															
None	Provided	2500 hours															
Provided	None	5000 hours															
None	None	Without filter timer															

<Parts layout of service P.C. board>







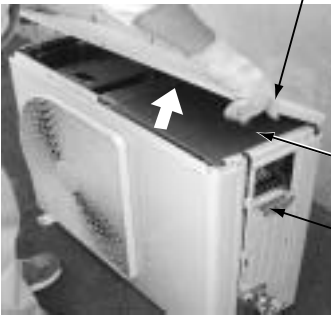
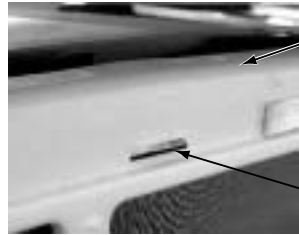
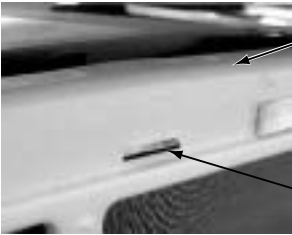

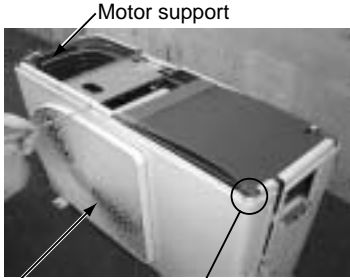
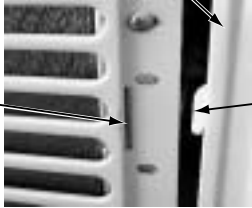
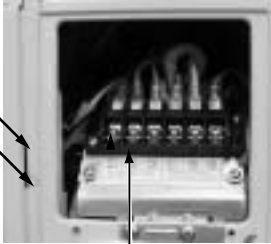
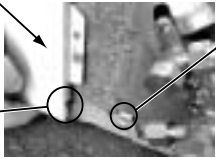
15-5. Outdoor Unit

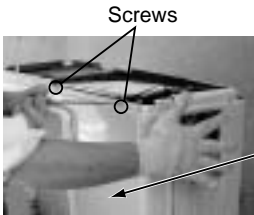
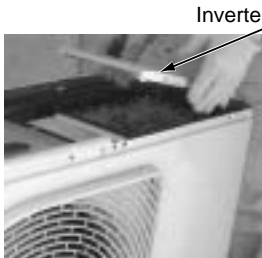

RAV-SM560AT-E

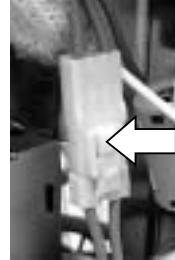
No.	Part name	Procedure	Remarks
①	Common procedure	<p style="text-align: center;">CAUTION</p> <p>Never forget to put on the gloves at working time, otherwise an injury will be caused by the parts, etc.</p> <p>1. Detachment</p> <ol style="list-style-type: none"> 1) Stop operation of the air conditioner, and turn off the main switch of the breaker for air conditioner. 2) Remove the valve cover. (ST1T Ø4 x 10L, 1 pc.) <ul style="list-style-type: none"> • After removing screw, remove the valve cover pulling it downward. 3) Remove wiring cover (ST1T Ø4 x 10L, 2 pcs.), and then remove connecting cable. 4) Remove the upper cabinet. (ST1T Ø4 x 10L, 2 pcs.) <ul style="list-style-type: none"> • After taking off screws, remove the upper cabinet pulling it upward. <p>2. Attachment</p> <ol style="list-style-type: none"> 1) Attach the waterproof cover. <p style="text-align: center;">CAUTION</p> <p>Be sure to attach a waterproof cover. If it is not attached, there is a possibility that water enters inside of the outdoor unit.</p> <ol style="list-style-type: none"> 2) Attach the upper cabinet. (ST1T Ø4 x 10L, 2 pcs.) <ul style="list-style-type: none"> • Hook the rear side of the upper cabinet to claw of the rear cabinet, and then put it on the front cabinet. 3) Perform cabling of connecting cables, and fix with cord clamp. (ST1T Ø4 x 10L 3 pcs.) 4) Attach the wiring cover. (ST1T Ø4 x 10L, 2 pcs.) 5) Attach the valve cover. (ST1T Ø4 x 10L, 1 pc.) <ul style="list-style-type: none"> • Insert the upper part of the upper cabinet, set hooking claw of the valve cover to the slit (at three positions) of the main body, and then attach it pushing upward. 	    

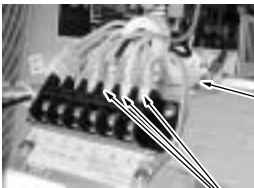
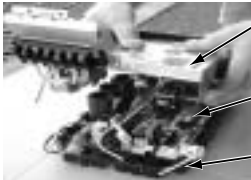
No.	Part name	Procedure	Remarks
②	Front cabinet	<p>1. Detachment</p> <ol style="list-style-type: none"> 1) Perform work of item 1 of ①. 2) Remove screws (ST1T Ø4 x 10L, 2 pcs.) of the front cabinet and the inverter cover. 3) Take off screws of the front cabinet and the bottom plate. (ST1T Ø4 x 10L 3 pcs.) 4) Take off screws of the front cabinet and the motor support. (ST1T Ø4 x 10L, 2 pcs.) <ul style="list-style-type: none"> • The left side of the front side is made to insert to the rear cabinet, so remove it pulling upward. <p>3. Attachment</p> <ol style="list-style-type: none"> 1) Insert hook at the left side of the front side into the rear cabinet. 2) Hook the lower part at the right side of the front to concavity of the bottom plate. Insert the hook of the rear cabinet into the slit of the front cabinet. 3) Attach the removed screws to the original positions. 	 <p>Motor support Front cabinet For single-phase type models, also take off this screw</p>  <p>Front cabinet (Left side) Slit Claw</p>  <p>Slit Hook Cord clamp</p>  <p>Front cabinet Lower slit Concavity at bottom plate</p>

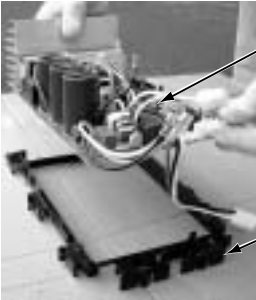
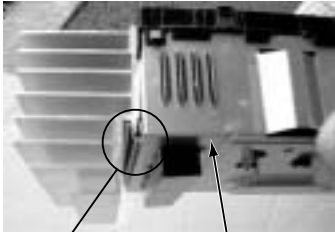

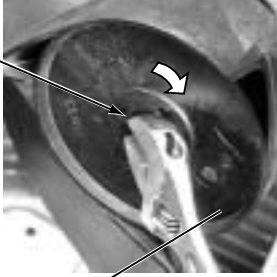
No.	Part name	Procedure	Remarks
③	Inverter assembly	<p>1. Detachment</p> <p>1) Perform work of item 1 of ①.</p> <p>2) Take off screws of the upper part of the front cabinet.</p> <ul style="list-style-type: none"> • If removing the inverter cover under this condition, P.C. board can be checked. • If there is no space in the upper part of the upper cabinet, perform work of ②. <div style="border: 1px solid black; border-radius: 10px; padding: 5px; text-align: center; margin: 10px 0;">CAUTION</div> <p>Be careful to check the inverter because high-voltage circuit is incorporated in it.</p> <p>3) Perform discharging by connecting ⊕, ⊖ polarities by discharging resistance (approx. 100Ω, 40W) or plug of soldering iron to ⊕, ⊖ terminals of the C14 (printed as "CAUTION HIGH VOLTAGE") electrolytic capacitor (500μF) of P.C. board.</p> <div style="border: 1px solid black; border-radius: 10px; padding: 5px; text-align: center; margin: 10px 0;">WARNING</div> <p>The electrolytic capacitor may not normally discharge according to error contents and the voltage may remain. Therefore, be sure to discharge the capacitor.</p> <div style="border: 1px solid black; border-radius: 10px; padding: 5px; text-align: center; margin: 10px 0;">WARNING</div> <p>For discharging, never use a screwdriver and others for short-circuiting between ⊕ and ⊖ electrodes. As the electrolytic capacitor is one with a large capacity, it is very dangerous because a large electric spark will occur.</p> <p>4) Take off screws (ST1T Ø4 x 10L, 2 pcs.) fixing the main body and the inverter box.</p> <p>5) Remove various lead wires from the holder at upper part of the inverter box and wiring holder at right side of the terminal block.</p> <p>6) Remove the lead wire from the bundled part at left side of the terminal block.</p> <p>7) Pull the inverter box upward.</p> <p>8) Disconnect connectors of various lead wires.</p> <div style="border: 1px solid black; border-radius: 10px; padding: 5px; text-align: center; margin: 10px 0;">REQUIREMENT</div> <p>As each connector has a lock mechanism, avoid to remove the connector by holding the lead wire, but by holding the connector.</p>	 <p>Screws</p> <p>Front cabinet</p>  <p>Inverter cover</p>  <p>Cord clamp</p> <p>Screws</p>  <p>Plug of soldering iron</p> <p>Discharging position (Discharging period 10 seconds or more)</p>  <p>Inverter assembly</p>  <p>Remove the connectors with locking function by pushing the part indicated by the arrow mark.</p>

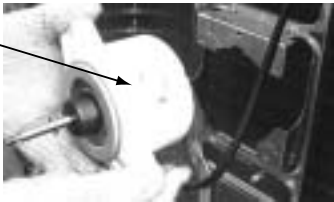
No.	Part name	Procedure	Remarks
④	Control P.C. board assembly	<p>1) Disconnect lead wires and connectors connected from the control P.C. board assembly to other parts.</p> <p>1. Lead wires</p> <ul style="list-style-type: none"> • Connection with the power terminal block: 3 wires (Black, White, Orange) • Earth wire: 1 wire (Black) <p>2. Connectors</p> <ul style="list-style-type: none"> • Connection with compressor: Remove 3P connector. • Connection with reactor: Remove the relay connectors from P07, 08 (2P, White) and P12, 13 (2P, Yellow) <p>CN300 : Outdoor fan (3P, White) CN301 : Position detection (5P, White) CN701 : 4-way valve (3P, Yellow) CN600 : TE sensor (2P, White) CN601 : TD sensor (3P, White) CN603 : TS sensor (3P, White) CN602 : TO sensor (3P, White) CN500 : Case thermo. (2P, White) CN703 : PMV (6P, White)</p> <p>2) Remove the inverter box (Metal plate).</p> <p>3) Remove the control board assembly from P.C. board base. (Remove the heat sink and the control board assembly as they are screwed.)</p> <p>NOTES:</p> <p>1. CN300, CN301 and CN701, etc. at the control board assembly side are connectors with locking function. Therefore, remove the connector while pushing the part indicated by an arrow mark.</p> <p>2. Remove 4 hooking claws of P.C. board base, and remove upward the heat sink with hands.</p> <p>4) Take off 3 screws fixing the heat sink and main control board assembly side, and replace the board with a new one.</p> <p>NOTE: When mounting a new board, check that the board is correctly set in the groove of the base holder of P.C. board base. Attach the P.C. board so that the heat sink comes securely contact with the metal sheet.</p>	 <p>Take off earth screws.</p> <p>Power line</p>  <p>Inverter box (Metal sheet)</p> <p>Control P.C. board assembly</p> <p>P.C. board base</p>  <p>Hooking claws (4 positions)</p>  <p>Control P.C. board assembly</p> <p>P.C. board base</p>  <p>Heat sink</p> <p>Inverter box (Metal sheet)</p>

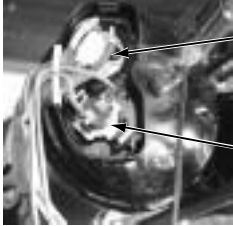
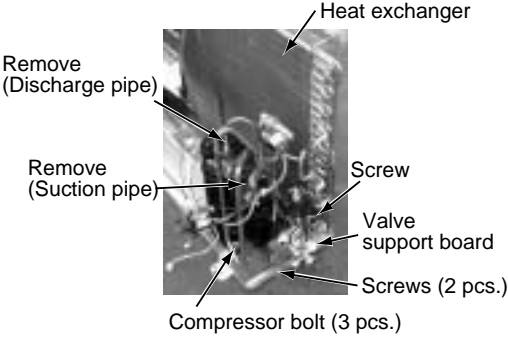
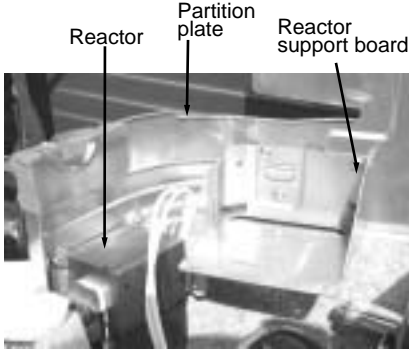
No.	Part name	Procedure	Remarks
⑤	Rear cabinet	1) Perform works of items 1 of ① and ②, ③. 2) Take off fixed screws for the bottom plate. (ST1T Ø4 x 10L, 3 pcs.) 3) Take off fixed screws for the heat exchanger. (ST1T Ø4 x 10L, 2 pcs.) 4) Take off fixed screw for the valve mounting plate. (ST1T Ø4 x 10L, 1 pc.)	
⑥	Fan motor	1) Perform works of items 1 of ① and ②. 2) Take off the flange nut fixing the fan motor and the propeller. <ul style="list-style-type: none"> • Turning it clockwise, the flange nut can be loosened. (To tighten the flange nut, turn counterclockwise.) 3) Remove the propeller fan. 4) Disconnect the connector for fan motor from the inverter. 5) Take off the fixing screws (3 pcs.) holding by hands so that the fan motor does not fall. <p>NOTE: Tighten the flange nut with torque 4.9Nm (50kgf/cm).</p>	 <p>Loosen the nut by turning clockwise</p>  <p>Propeller fan</p>  <p>Fan motor</p>

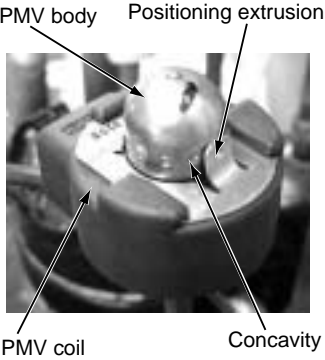
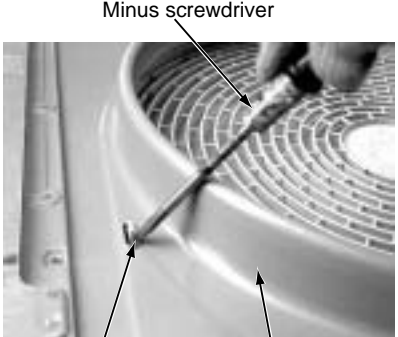
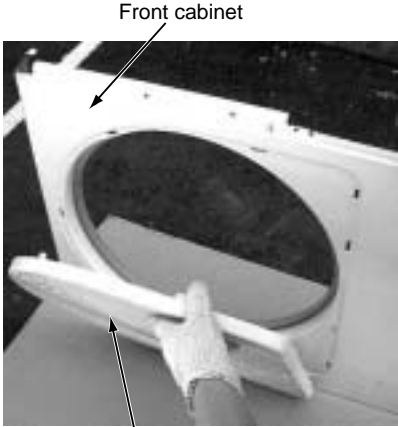
No.	Part name	Procedure	Remarks
⑦	Compressor	<ol style="list-style-type: none"> 1) Perform works of items 1 of ① and ②, ③, ④, ⑤. 2) Discharge refrigerant gas. 3) Remove the partition plate. (ST1T Ø4 x 10L, 2 pcs.) 4) Remove the noise-insulator. 5) Remove the terminal covers of the compressor, and disconnect lead wires of the compressor and the compressor thermo assembly from the terminal. 6) Remove pipes connected to the compressor with a burner. <div style="border: 1px solid black; border-radius: 10px; padding: 5px; margin: 10px 0; text-align: center;"> <p>CAUTION</p> <p>Pay attention to that flame does not involve 4-way valve or PMV. (If doing so, a malfunction may be caused.)</p> </div> <ol style="list-style-type: none"> 7) Take off the fixing screws of the bottom plate and heat exchanger. (ST1T Ø4 x 10L, 2 pcs.) 8) Take off the fixing screws of the valve clamping plate to the bottom plate. 9) Pull upward the refrigerating cycle. 10) Take off nut fixing the compressor to the bottom plate. <div style="border: 1px solid black; border-radius: 10px; padding: 5px; margin: 10px 0; text-align: center;"> <p>CAUTION</p> <p>When reconnecting the lead wires to the compressor terminals after replacement of the compressor, be sure to caulk the Faston terminal without loosening.</p> </div>	<p style="text-align: center;">Partition plate</p>   
⑧	Reactor	<ol style="list-style-type: none"> 1) Perform works of item 1 of ① and ③. 2) First take off two screws (ST1T Ø4 x 10L) of the reactor fixed to the reactor support. 3) Remove the reactor support from the partition plate. (ST1T Ø4 x 10L, 4 pcs.) 4) Take off two screws (ST1T Ø4 x 10L) directly attached to the partition plate. 	



No.	Part name	Procedure	Remarks
⑨	Pulse Modulating Valve (PMV) coil	<p>1. Detachment</p> <ol style="list-style-type: none"> 1) Perform works of items ① and ②. 2) Release the coil from the concavity by turning it, and remove coil from the PMV. <p>2. Attachment</p> <ol style="list-style-type: none"> 1) Put the coil deep into the bottom position. 2) Fix the coil firmly by turning it to the concavity. 	
⑩	Fan guard	<p>1. Detachment</p> <ol style="list-style-type: none"> 1) Perform works of items 1 of ①, and ②. 2) Remove the front cabinet, and put it down so that fan guard side directs downward. <div style="border: 1px solid black; border-radius: 10px; padding: 5px; text-align: center; margin: 10px 0;"> <p>CAUTION</p> <p>Perform works on a corrugated cardboard, cloth, etc. to prevent flaw on the product.</p> </div> <ol style="list-style-type: none"> 3) Remove the hooking claws by pushing with minus screwdriver along with the arrow mark in the right figure, and remove the fan guard. <p>2. Attachment</p> <ol style="list-style-type: none"> 1) Insert claws of the fan guard in the hole of the front cabinet. Push the hooking claws (10 positions) with hands and then fix the claws. <div style="border: 1px solid black; border-radius: 10px; padding: 5px; text-align: center; margin: 10px 0;"> <p>CAUTION</p> <p>All the attaching works have completed. Check that all the hooking claws are fixed to the specified positions.</p> </div>	 

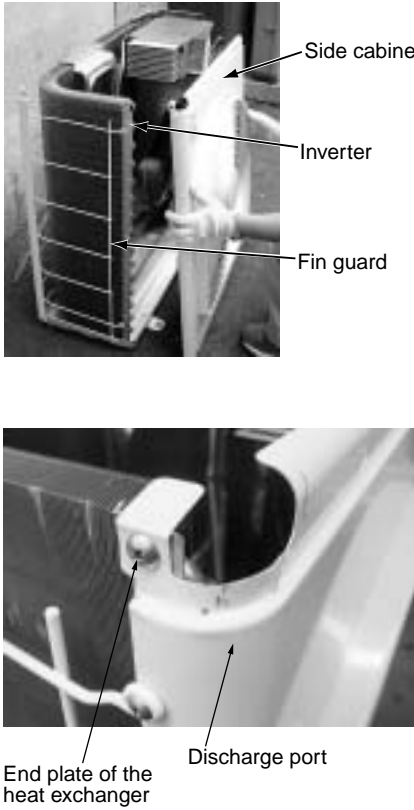
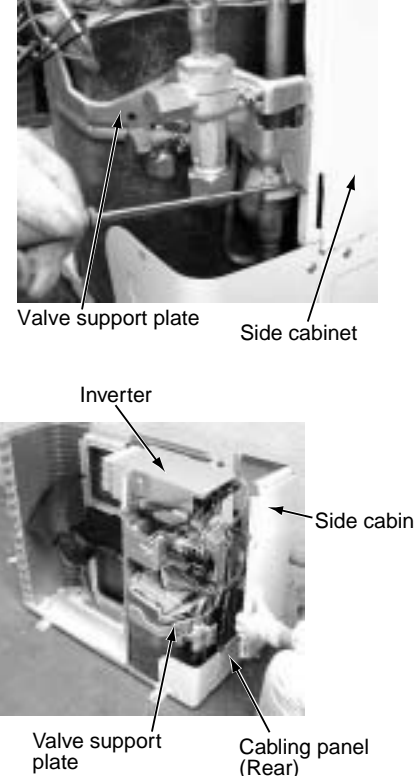

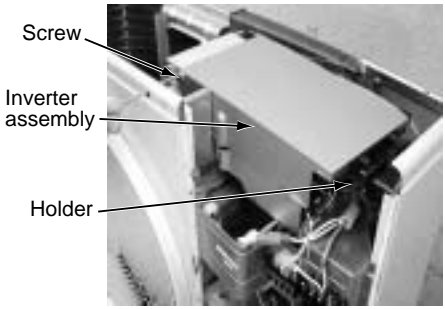
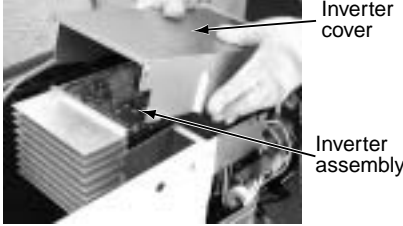
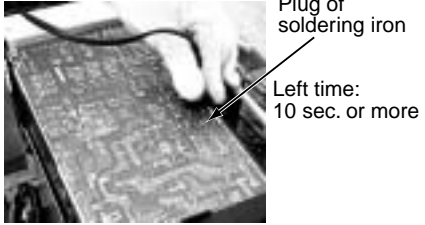
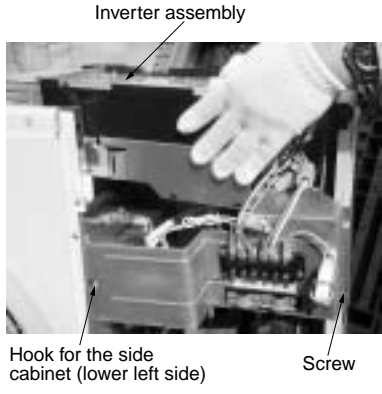
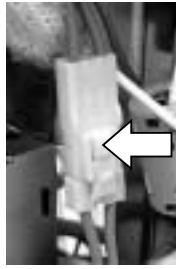
No.	Part name	Procedure	Remarks
①	Common procedure	<p style="text-align: center;">CAUTION</p> <p>Never forget to put on the gloves at working time, otherwise an injury will be caused by the parts, etc.</p> <p>1. Detachment</p> <ol style="list-style-type: none"> 1) Stop operation of the air conditioner, and also turn off switch of the breaker. 2) Remove the front panel. (ST1T Ø4 x 10L, 3 pcs.) <ul style="list-style-type: none"> • After taking off screws, remove the front panel by pulling it downward. 3) Disconnect the connecting cables and power cord from the terminals and cord clamp. 4) Remove the upper cabinet. (ST1T Ø4 x 10L, 6 pcs.) <p>2. Attachment</p> <ol style="list-style-type: none"> 1) Attach the waterproof cover. <p style="text-align: center;">CAUTION</p> <p>Be sure to attach a waterproof cover. If it is not attached, there is a possibility that water enters inside of the outdoor unit.</p> <ol style="list-style-type: none"> 2) Attach the upper cabinet. (ST1T Ø4 x 10L, 6 pcs.) 3) Connect the connecting cable and power cord at the terminal and fix them with cord clamp. <p style="text-align: center;">CAUTION</p> <p>Using bundling band sold at a market, be sure to fix the power cables and indoor/outdoor connecting cables along the inter-unit cable so that they do not come to contact with the compressor, valves and cables at gas side, and the discharge pipe.</p> <ol style="list-style-type: none"> 4) Attach the front cabinet. (ST1T Ø4 x 10L, 3 pcs.) 	 <p>Front cabinet</p>  <p>Upper plate of cabinet</p> <p>Water-proof cove</p>

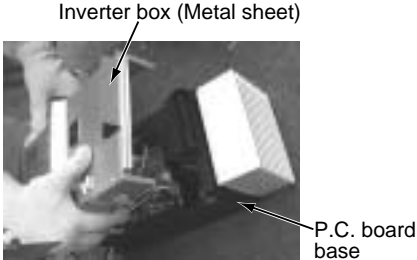
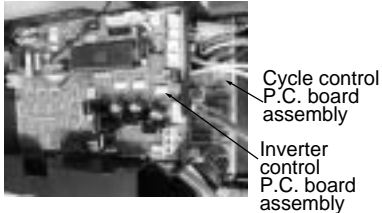
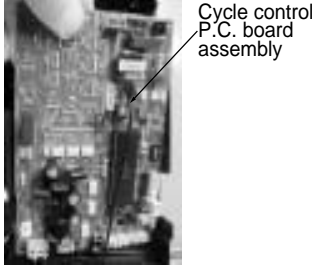
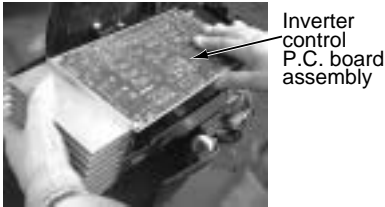
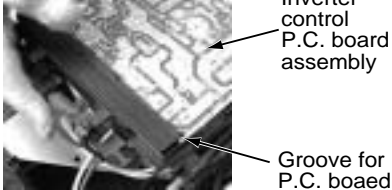
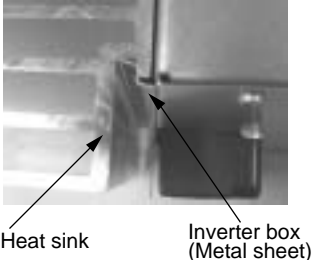
No.	Part name	Procedure	Remarks
②	Discharge port cabinet	<p>1. Detachment</p> <ol style="list-style-type: none"> 1) Perform work of item 1 of ①. 2) Take off screws (ST1T Ø4 x 10L, 3 pcs.) of discharge port cabinet for the partition plate. 3) Take off screws (ST1T Ø4 x 10L, 2 pcs.) of discharge port cabinet for the bottom plate. 4) Take off screw (ST1T Ø4 x 10L, 1 pc.) of discharge port cabinet for the heat exchanger. 5) Take off screws (ST1T Ø4 x 10L, 2 pcs.) of discharge port cabinet for the fin guard. <p>2. Attachment</p> <ol style="list-style-type: none"> 1) Put the upper left side of the discharge port cabinet on the end plate of the heat exchanger, and then fix it with screw. (ST1T Ø4 x 10L, 1 pc.) 2) Attach the removed screws to the original positions. 	 <p>Side cabinet Inverter Fin guard</p> <p>End plate of the heat exchanger Discharge port</p>
③	Side cabinet	<ol style="list-style-type: none"> 1) Perform work of item 1 of ①. 2) Remove screw fixing the inverter and the side cabinet. (ST1T Ø4 x 10, 1 pc.) 3) Remove screws of the side cabinet and the valve support plate. (ST1T Ø4 x 10, 2 pcs.) 4) Remove screw of the side cabinet and the cabling panel (Rear). (ST1T Ø4 x 10, 1 pc.) 5) Remove screw of the side cabinet and the bottom plate. (ST1T Ø4 x 10, 1 pc.) 6) Remove screw of the side cabinet and the fin guard (Heat exchanger). (ST1T Ø4 x 10, 2 pcs.) 	 <p>Valve support plate Side cabinet</p> <p>Inverter Side cabinet Valve support plate Cabling panel (Rear)</p>

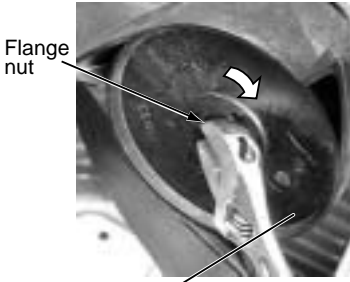
No.	Part name	Procedure	Remarks
④	Inverter assembly	<p>1) Perform works of items of 1) to 5) of ①.</p> <p>2) Take off screw (ST1T Ø4 x 10L, 1 pc.) of the upper left part of the inverter cover.</p> <ul style="list-style-type: none"> • If removing the inverter cover under this condition, P.C. board can be checked. • If there is no space in the upper part of the upper cabinet, perform works of items 6) to 7) of (1) and remove the partition fixing plate. (ST1T Ø4 x 10L, 1 pc.) <p style="text-align: center;">CAUTION</p> <p>Be careful to check the inverter because high-voltage circuit is incorporated in it.</p> <p>3) Perform discharging by connecting the discharging resistance (approx. 100Ω, 40W) or plug of soldering iron to ⊕, ⊖ terminals of the C10 too 13 (printed as "CAUTION HIGH VOLTAGE") electrolytic capacitor (760μF) of P.C. board.</p> <p style="text-align: center;">WARNING</p> <p>The electrolytic capacitor may not normally discharge according to error contents and the voltage may remain. Therefore, be sure to discharge the capacitor.</p> <p style="text-align: center;">WARNING</p> <p>For discharging, never use a screwdriver and others for short-circuiting between ⊕ and ⊖ electrodes. As the electrolytic capacitor is one with a large capacity, it is very dangerous because a large electric spark will occur.</p> <p>4) Remove various lead wires from the holder at upper part of the inverter box.</p> <p>5) Remove the hook for the partition plate (lower left side).</p> <p>6) Remove the hook for the side cabinet (lower left side) and the screw, and lift up the inverter assembly upward. (ST1T Ø4 x 10L, 1 pc.) In this time, cut off the band bundling each lead wire.</p> <p>7) Disconnect connectors of various lead wires.</p> <p style="text-align: center;">REQUIREMENT</p> <p>As each connector has a lock mechanism, avoid to remove the connector by holding the lead wire, but by holding the connector.</p>	     <p>Remove the connectors with locking function by pushing the part indicated by the arrow mark.</p>

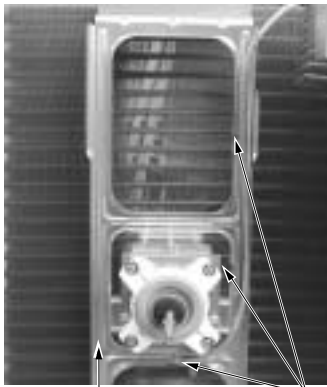
No.	Part name	Procedure	Remarks
⑤	Control P.C. board assembly	<p>1) Remove the inverter box from P.C. board base.</p> <p>2) Disconnect lead wires and connectors connected from the control P.C. board assembly to other parts.</p> <p>1. Lead wires:</p> <p>With the power terminal block: 2 pcs. (Single phase) (Red, White)</p> <p>With the compressor: 3 pcs. (Red, White, Black)</p> <p>2. Connectors</p> <p>CN301 : Outdoor fan (3P, White) *Note 1) CN300 : Position detection (5P, White) CN700 : 4-way valve (3P, Yellow) *Note 1) CN702 : PMV coil (6P, White) CN600 : TD sensor (3P, White) CN605 : TS sensor (3P, White) *Note 1) CN604 : TE sensor (2P, White) *Note 1) CN601 : TO sensor (2P, White) CN02 : Indoor/Outdoor connecting terminal block (2P, Black) CN500 : Case thermo (2P, White) *Note 1) CN14, CN15 : Reactor (3P, Relay connector, Blue) *Note 1)</p> <p>*Note 1) Remove the connector while releasing locking of the housing.</p> <p>3) Remove the control P.C. board assembly from P.C. board base. (Remove the heat sink and the inverter control P.C. board assembly as they are screwed.)</p> <p>Note 2) Remove the heat sink upward by taking off two claws of P.C. base and holding the heat sink.</p> <p>4) Take off three screws fixing the heat sink to the control P.C. board assembly.</p> <p>5) Mount a new control P.C. board assembly.</p> <p>Note 3) When mounting a new board, check that it is correctly set in the groove of the base holder of P.C. board base.</p>	 <p>Inverter box (Metal sheet)</p> <p>P.C. board base</p>  <p>Cycle control P.C. board assembly</p> <p>Inverter control P.C. board assembly</p>  <p>Cycle control P.C. board assembly</p>  <p>Inverter control P.C. board assembly</p>  <p>Inverter control P.C. board assembly</p> <p>Groove for P.C. board</p>  <p>Heat sink</p> <p>Inverter box (Metal sheet)</p>

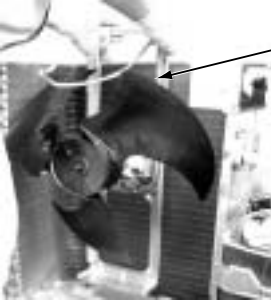
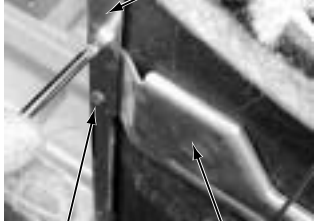
No.	Part name	Procedure	Remarks
⑥	Fan motor	<p>1) Perform works of items 1) to 5), 7) of ①</p> <p>2) Remove the flange nut fixing the fan motor and the propeller fan.</p> <ul style="list-style-type: none"> • Loosen the flange nut by turning clockwise. (To tighten the flange nut, turn it counterclockwise.) <p>3) Remove the propeller fan.</p> <p>4) Remove the lead wire from the hook fixing the fan motor lead wires on the motor base. (Three positions)</p> <p>5) Disconnect the connector for fan motor from the inverter.</p> <p>6) Take off the fixing screws (4 pcs.) while holding by hands so that the fan motor does not fall.</p> <p>NOTE : Tighten the flange nut with torque 9.8Nm (100kgf/cm).</p>	 <p>Flange nut</p> <p>Loosen by turning clockwise</p>  <p>Propeller fan</p>  <p>Fan motor</p>  <p>Motor base</p> <p>Fixing claws for fan motor lead wires (3 positions)</p>

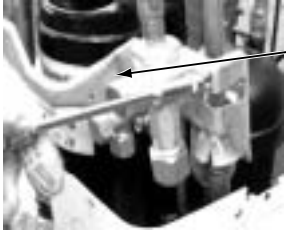
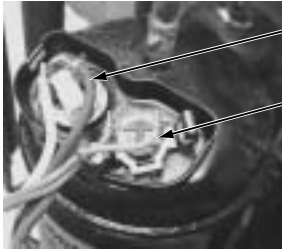
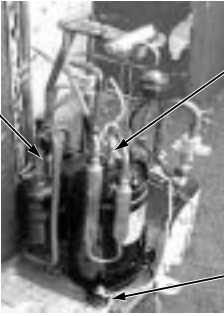
No.	Part name	Procedure	Remarks
⑥	Compressor	<ol style="list-style-type: none"> 1) Perform works of items ①, ②, ③, ④, and ⑤. 2) Evacuate refrigerant gas. 3) Disconnect the connector for fan motor from the inverter. 4) Take off screws fixing the motor base to the bottom plate. (ST1T Ø4 x 10L, 2 pcs.) 5) Remove the motor base together with the fan motor and the propeller fan. 6) Take off screws fixing the partition plate to the valve support plate. (ST1T Ø4 x 10L, 2 pcs.) 7) Remove the valve support plate. (M6 x 4 pcs.) 8) Take off screws of the partition plate and the bottom plate. (ST1T Ø4 x 10L, 2 pcs.) 9) Take off screws of the partition plate and the heat exchanger. (ST1T Ø4 x 10L, 2 pcs.) 10) Remove the noise-insulator. 11) Remove the terminal covers of the compressor, and disconnect lead wires of the compressor and the compressor thermo assembly from the terminal. 12) Remove pipes connected to the compressor with a burner. <div style="border: 1px solid black; border-radius: 10px; padding: 5px; margin: 10px 0; text-align: center;"> <p>CAUTION</p> <p>Pay attention to that flame does not involve 4-way valve or PMV. (If doing so, a malfunction may be caused.)</p> </div> <ol style="list-style-type: none"> 13) Pull the refrigerating cycle upward. 14) Take off nut fixing the compressor on the bottom plate. (3 pcs.) 15) Pull the compressor toward you. <div style="border: 1px solid black; border-radius: 10px; padding: 5px; margin: 10px 0; text-align: center;"> <p>CAUTION</p> <p>When reconnecting the lead wires to the compressor terminals after replacement of the compressor, be sure to caulk the Faston terminal without loosening.</p> </div>	 <p>Motor base</p>  <p>Partition plate</p> <p>Screw</p> <p>Valve support</p>  <p>Partition plate</p>  <p>Valve support</p>  <p>Compressor lead wire</p> <p>Case thermo</p>  <p>Remove (Suction pipe)</p> <p>Remove (Discharge pipe)</p> <p>Compressor nut (3 pcs.)</p>

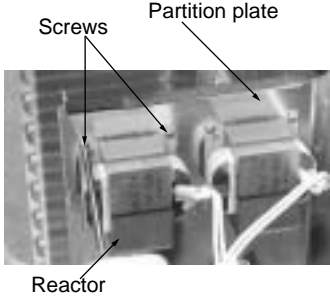
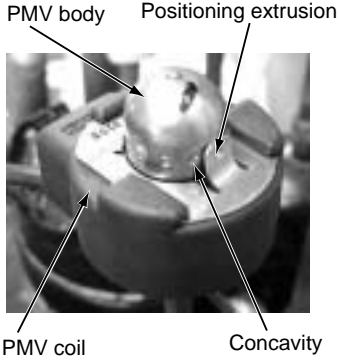
No.	Part name	Procedure	Remarks
⑧	Reactor	1) Perform works of items 1 of ① and ④. 2) Take off screws fixing the reactor. (Ø4 x 10L , 2 pcs. per one reactor. An outdoor unit has two reactors on the partition plate.)	
⑨	Pulse Modulating Valve (PMV) coil	1. Detachment 1) Perform works of items 1 of ① and ③. 2) Remove the coil from PMV body while pulling it upward. 2. Attachment 1) Match the positioning extrusion of the coil surely to the concavity of PMV body to fix it.	

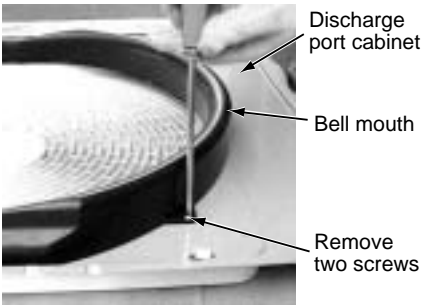
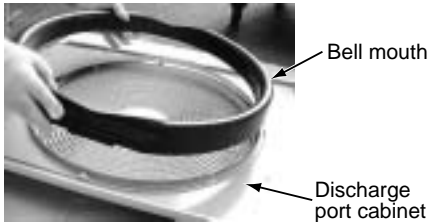
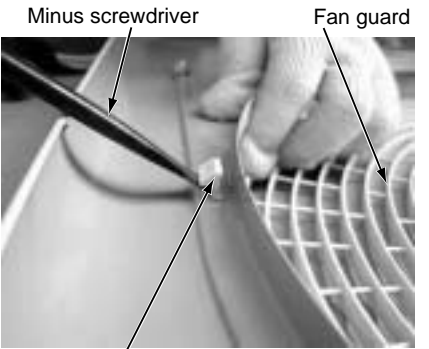
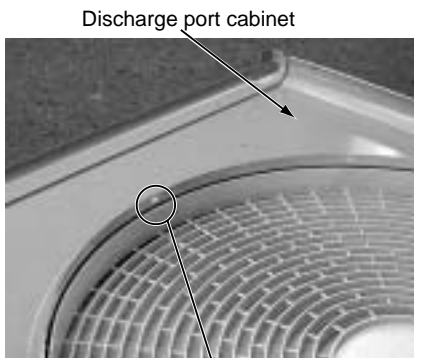
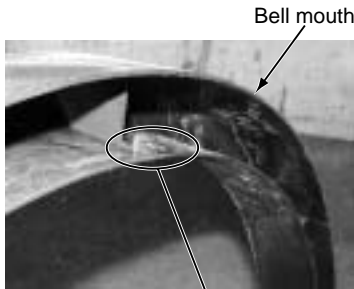
No.	Part name	Procedure	Remarks
⑩	Fan guard	<p>1. Detachment</p> <p>1) Perform works of items 1 of ① and ④.</p> <p>2) Remove the air flow cabinet, and put it down so that the fan guard side directs downward.</p> <div data-bbox="416 412 944 533" style="border: 1px solid black; padding: 5px; margin: 10px 0;"> <p>Perform work on a corrugated cardboard, cloth, etc. to prevent flaw to the product.</p> </div> <p>3) Take off screws fixing the bell mouth. (ST1Tf4 x 10L, 2 pcs.)</p> <p>4) Remove the bell mouth.</p> <p>5) Remove the hooking claws by pushing with minus screwdriver along with the arrow mark as shown in right figure.</p> <p>2. Attachment</p> <p>1) Insert claw of the fan guard in hole of the discharge panel. Push the hooking claws (5 positions) with hands and fix the claws.</p> <div data-bbox="416 927 944 1077" style="border: 1px solid black; padding: 5px; margin: 10px 0;"> <p>After all the attachment works are completed, check that all the hooking claws are fixed to the specified positions.</p> </div> <p>2) Mount the bell mouth by hooking three claws at upper side of the bell mouth in the slits on the discharge cabinet.</p> <p>3) After attachment, fix the bell mouth with screws. (ST1Tf4 x 10L, 2 pcs.)</p>	    

16. EXPLODED VIEWS AND PARTS LIST

16-1. Indoor Unit

4-Way Air Discharge Cassette Type RAV-SM560UT-E/RAV-SM800UT-E

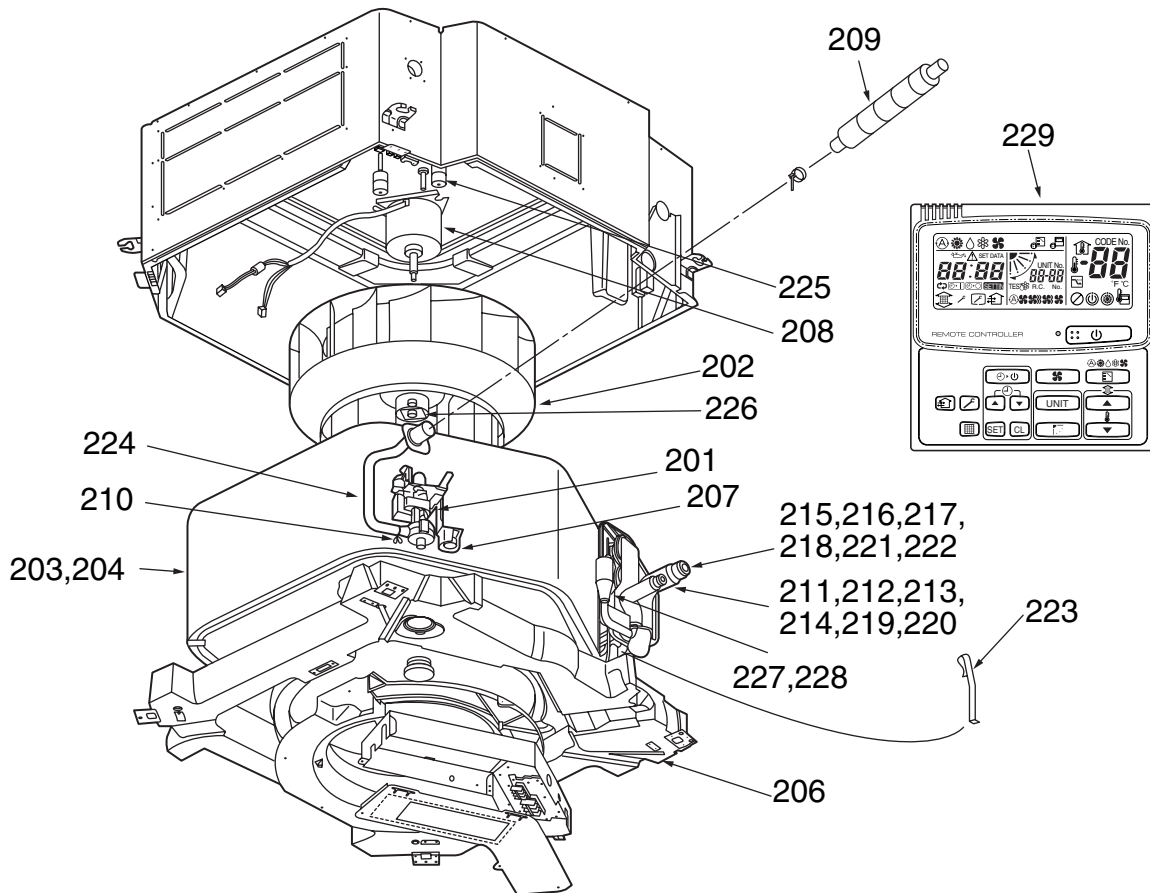

Location No.	Part	Description
201	43121703	Pump, Drain, ADP-1409, 220-240V
202	43120215	Fan, Ass'y Turbo, TJ461
203	4314J122	Refrigeration Cycle Ass'y
204	4314J123	Refrigeration Cycle Ass'y
205	4318T313	Owner's Manual
206	43172160	Pan Ass'y, Drain, PS-F+ABS, Sheet
207	43151279	Switch, Float, FS-0218-106
208	43121692	Motor, Fan, SWF-230-60-1
209	43170232	Hose, Drain, 25A
210	43079249	Band, Hose
211	43047545	Nut, Flare, 1/4 IN, Ø6.35
212	43047546	Nut, Flare, 3/8 IN, Ø9.52
213	43194051	Socket, Ø6.35
214	43194026	Socket, Ø9.52
215	43194081	Nut, Flare, 1/2 IN, Ø12.7

Location No.	Part	Description
216	43194078	Nut, Flare, 5/8 IN, Ø15.88
217	43194080	Socket, 1/2 IN, Ø12.7
218	43194079	Socket, 5/8 IN, Ø15.88
219	43049697	Bonnet, Ø6.35
220	43047609	Bonnet, Ø9.52
221	43147195	Bonnet, 1/2 IN, Ø12.7
222	43194029	Bonnet, Ø15.88
223	43019904	Holder, Sensor, SUS
224	43170231	Hose, Drain
225	43139137	Rubber, Cushion
226	43097204	Nut
227	43147656	Distributor Ass'y (SM560UT)
228	43147657	Distributor Ass'y (SM800UT)
229	4316V194	Remote Controller, SX-A3JE
230	4316V195	Remote Controller, SX-A11JE
231	4316V196	Remote Controller, WX-W2JE
232	4316V197	Remote Controller, WH-H1JE

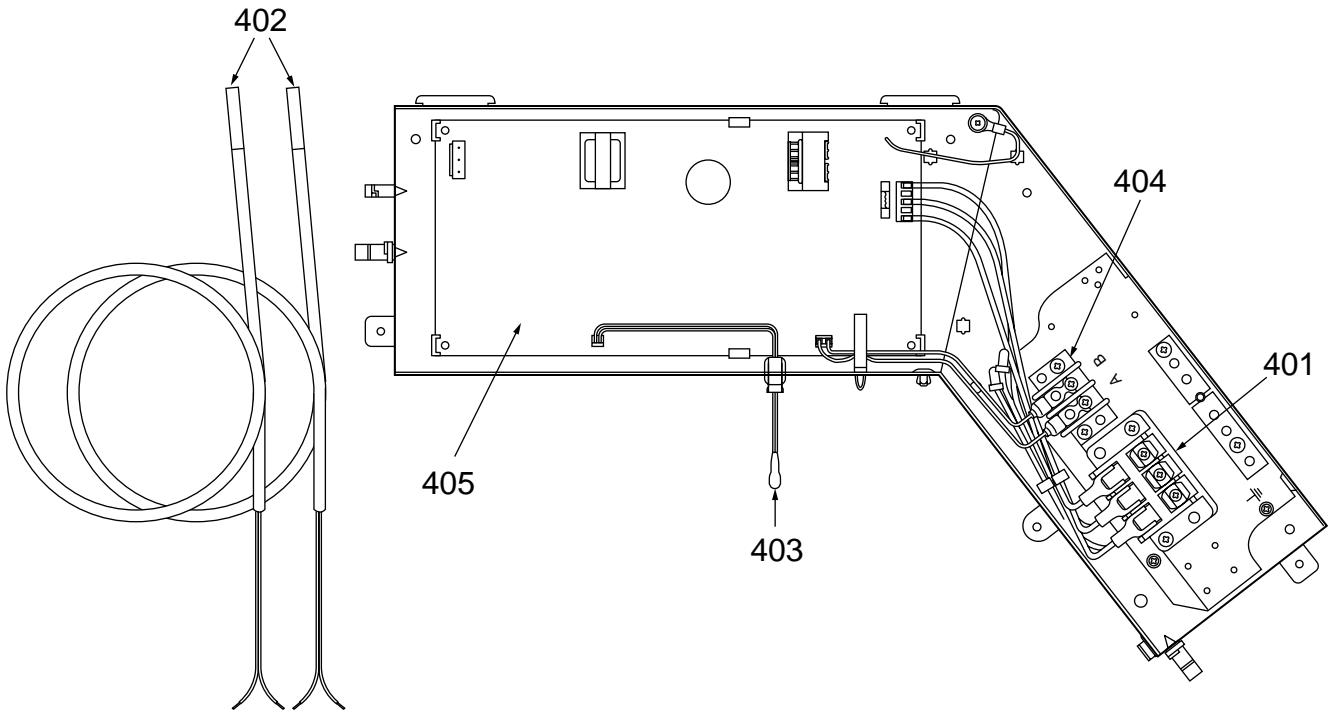

Location No.	Part	Description
401	43060750	Terminal Block, 3P
402	43050382	Sensor, TC (F6)
403	43150297	Sensor, TC
404	43160445	Terminal Block, 2P, 1A, AC30V
405	4316V188	P.C. Board Ass'y, MMC-1402

Concealed Duct Type
RAV-SM560BT-E/RAV-SM800BT-E

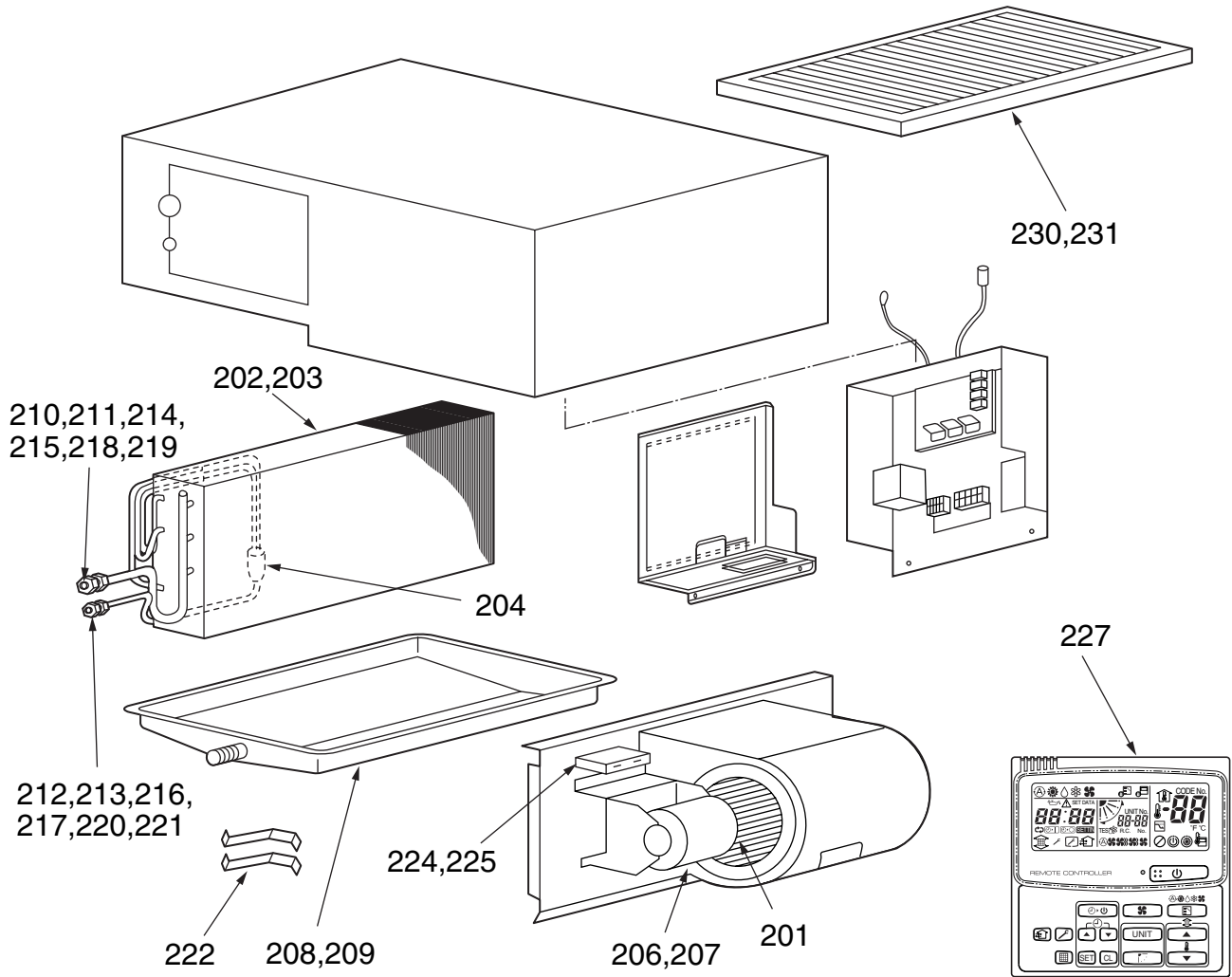

Location No.	Part	Description
201	43120149	Fan, Multi Blade
202	4314J100	Refrigeration Cycle Ass'y
203	4314J101	Refrigeration Cycle Ass'y
204	43147654	Distributor Ass'y
205	43147655	Distributor Ass'y
206	43121643	Motor, Fan
207	43121645	Motor, Fan
208	43191304	Pan, Drain
209	43191305	Pan, Drain
210	43047545	Nut, Flare, 1/4 IN, Ø6.35
211	43047546	Nut, Flare, 3/8 IN, Ø9.52
212	43194081	Nut, Flare, 1/2 IN, Ø12.7
213	43194078	Nut, Flare, 5/8 IN, Ø15.88
214	43194051	Socket, Ø6.35
215	43194026	Socket, Ø9.52
216	43194080	Socket, 1/2 IN, Ø12.7
217	43194079	Socket, 5/8 IN, Ø15.88

Location No.	Part	Description
218	43049697	Bonnet, Ø6.35
219	43047609	Bonnet, Ø9.52
220	43147195	Bonnet, 1/2 IN, Ø12.7
221	43194029	Bonnet, Ø15.88
222	43019822	Holder, Sensor, SUS
223	43160394	Connector, 9P
224	43155088	Capacitor, Electrolytic, 2.5MFD, 500V
225	43155096	Capacitor, Electrolytic, 5MFD, 400V
226	43121688	Pump, Drain, PJD-05230TF, 220-240V 50/60Hz
227	4316V194	Remote Controller, SX-A3JE
228	4316V195	Remote Controller, SX-A11JE
229	4316V196	Remote Controller, WX-W2JE
230	43119462	Filter (SM560BT-E)
231	43119463	Filter (SM800BT-E)

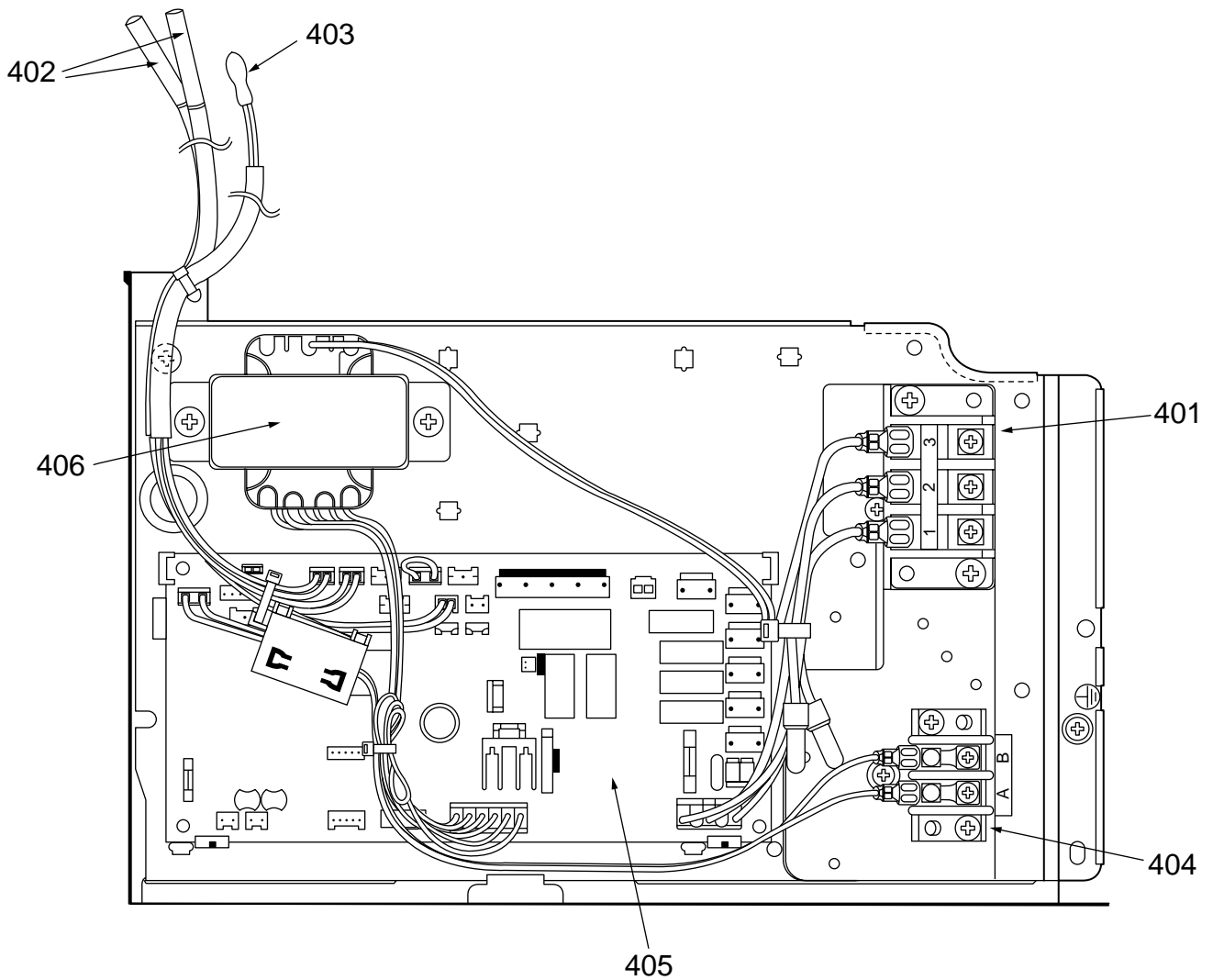

Location No.	Part	Description
401	43060750	Terminal Block, 3P
402	43050382	Sensor, TC (F6)
403	43150299	Sensor, TA
404	43160445	Terminal Block, 2P, 1A, AC30V
405	4316V189	P.C. Board Ass'y, MCC-1403 (220-240V)
406	43158180	Transformer, TT-09 (AC220-240V)

RBC-U21PG(W) - E

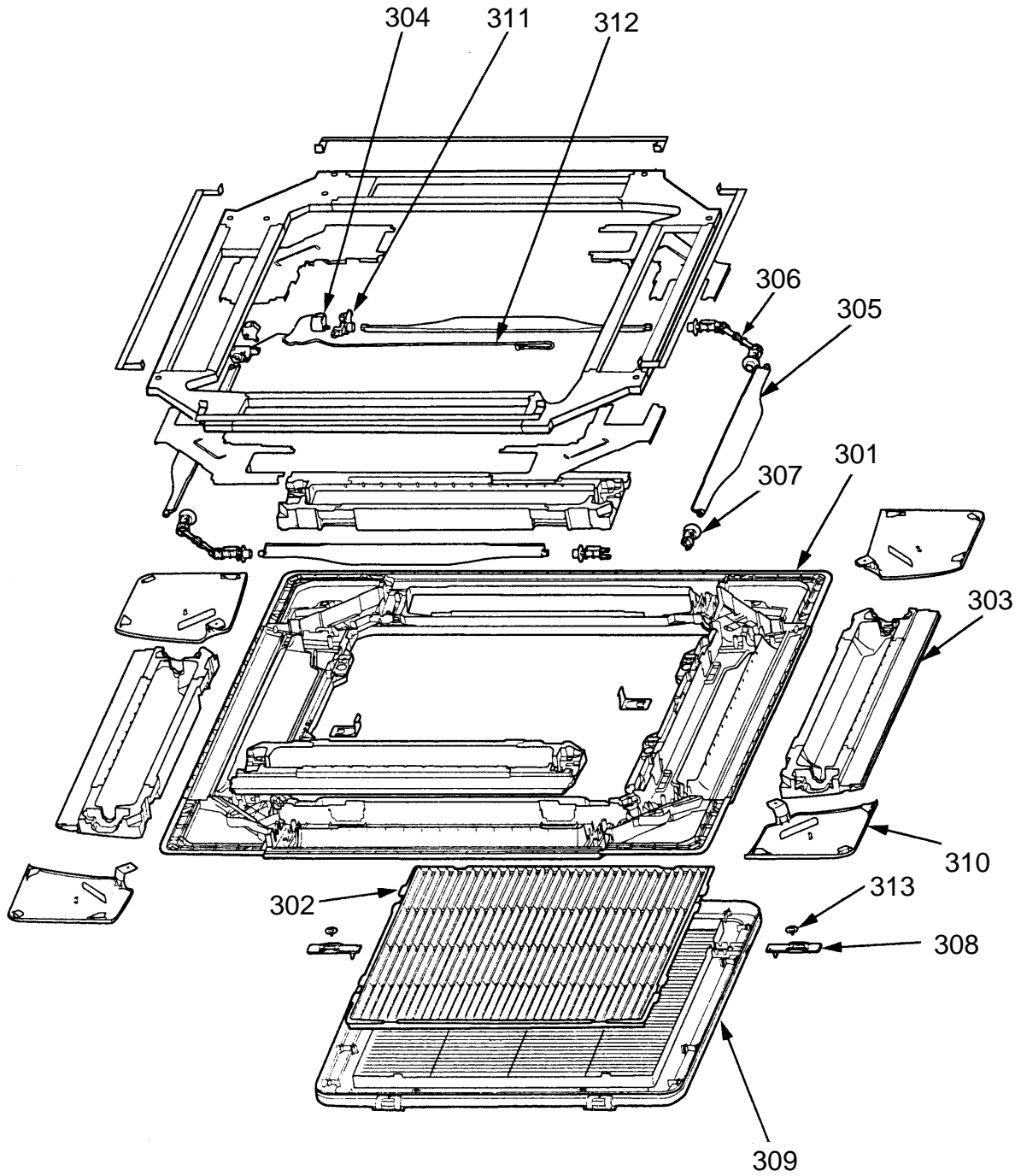

Location No.	Part	Description
301	43409164	Panel, PS-HI100
302	43480010	Air Filter, ABS
303	43407120	Outlet, Air Form, PS-F
304	4302C029	Motor, Louver, MP24GA
305	43409173	Louver, ABS
306	43422001	Joint, Kit
307	43422002	Joint, Kit

Location No.	Part	Description
308	43407116	Grille, Catch, ABS
309	43409168	Grille, Air, Inlet
310	43409182	Cover, Panel Ass'y, PS-HI100
311	43407123	Fix, Motor, ABS
312	43460108	Lead, Motor
313	43482025	Washer, SPCC

High-Wall Type
RAV-SM560KRT-E/RAV-SM800KRT-E

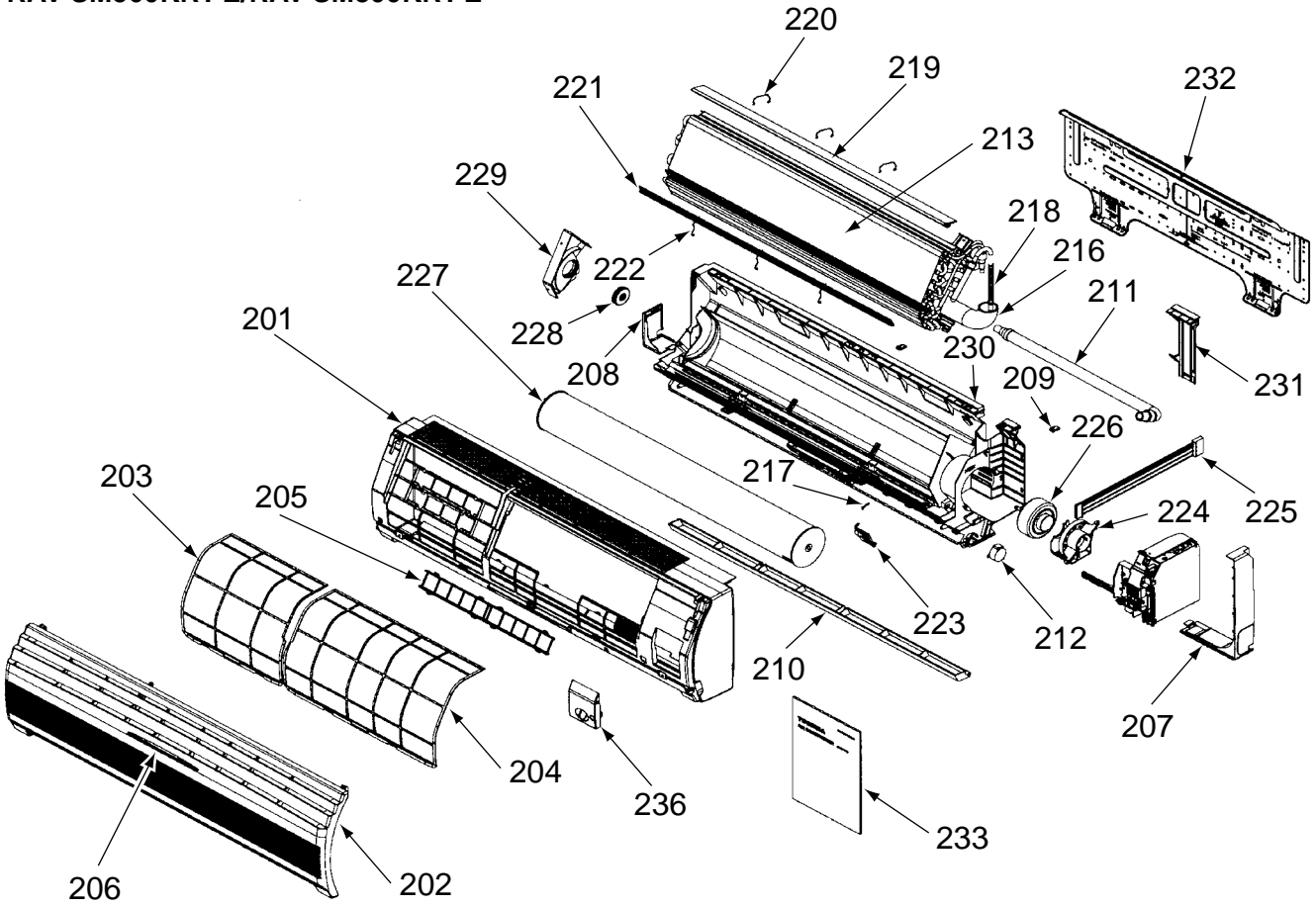

Location No.	Part	Description
201	43T00355	Front Panel Ass'y
202	43T00356	Grille Ass'y
203	43T80014	Air Filter, (L)
204	43T80013	Air Filter, (R)
205	43T80003	Filter, Frame
206	43T01004	Mark
207	43T03010	Body, Right
208	43T03011	Body, Left
209	43T03012	Hide, Claw
210	43T09317	Grille, Horizontal
211	43T70301	Hose Ass'y, Drain
212	43T21302	Motor, Stepping, MP35EA12
213	43T44316	Refrigeration Cycle Ass'y (SM560KRT-E)
213	42T44317	Refrigeration Cycle Ass'y (SM800KRT-E)
216	43T11002	Pipe, Shield
216	43T11306	Pipe, Shield (SM800KRT-E)

Location No.	Part	Description
217	43T19003	Holder, Sensor
218	43T49009	Spring
219	43T49036	Plate, EVA, Seal
220	43T49039	Holder, Plate EVA, Seal (U)
221	43T49038	Plate EVA, Seal (D)
222	43T49037	Holder, Plate EVA, Seal (D)
223	43T79007	Guide, Drain
224	43T39016	Fix Motor
225	43T60075	Fan Motor Cord
226	43T21327	Motor, Fan, ICF-340-30-2
227	43T20014	Fan, Cross Flow
228	43T22008	Bearing
229	43T39015	Base, Bearing
230	43T03305	Back Body Ass'y
231	43T07022	Holder, Pipe
232	43T82007	Plate, Installation
233	43T85400	Owner's Manual
236	43T62029	Cover, Terminal

RAV-SM560KRT-E/RAV-SM800KRT-E

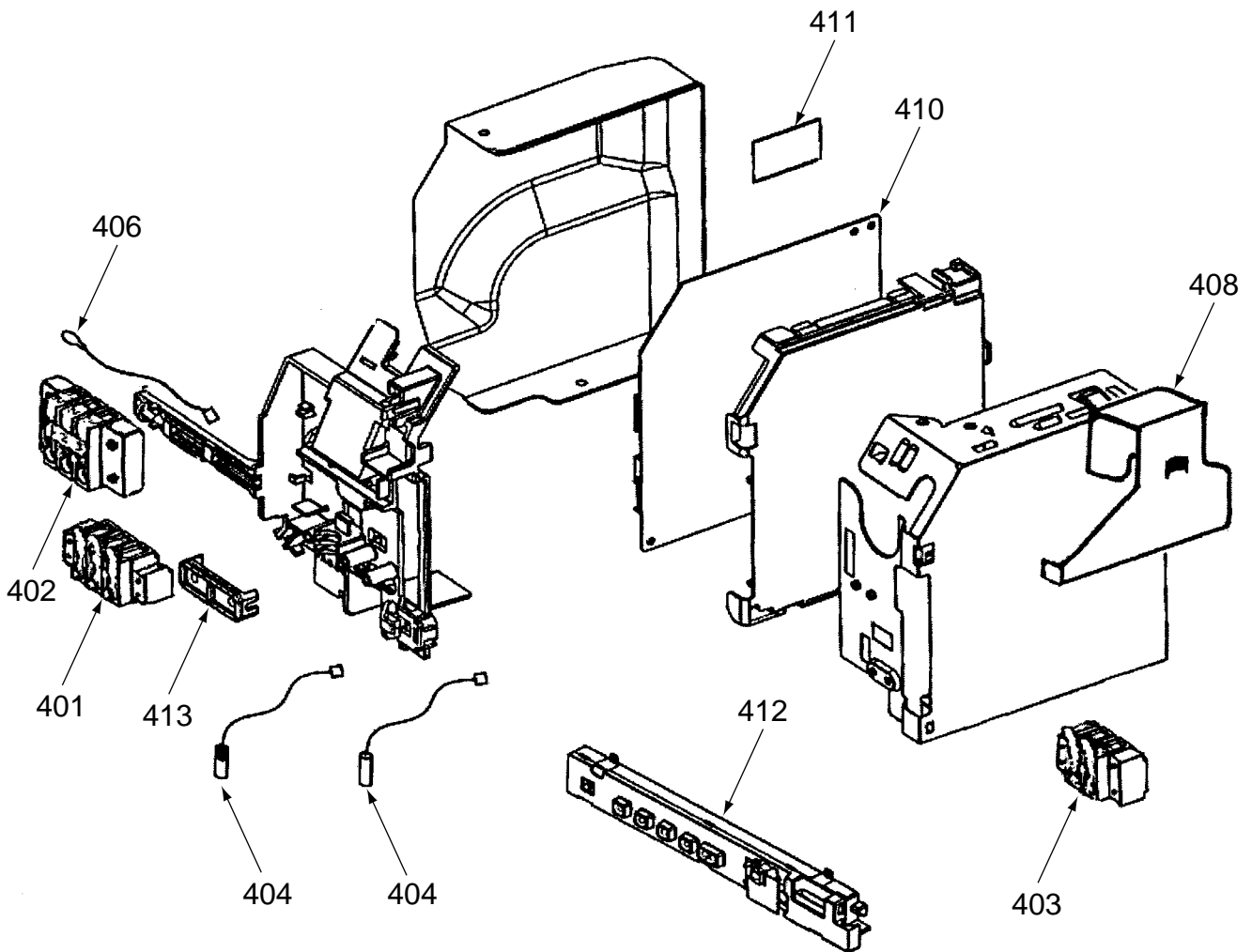

Location No.	Part	Description
401	43T60047	Terminal, 3P
402	43T60320	Terminal, 3P
403	43T60321	Terminal, 2P
404	43T50304	Temperature Sensor, TC, TCJ
406	43T69005	Sensor, Thermostat, TA
408	43T58302	Transformer, TT-02
410	43T69346	P.C. Board, Ass'y, MCC-1370A, MCC-1370B (SM560KRT-E)

Location No.	Part	Description
410	43T69347	P.C. Board, Ass'y, MCC-1370A, MCC-1370B (SM800KRT-E)
411	43T69325	P.C. Board, Ass'y, AI, MCC-1337
412	43T69066	P.C. Board Ass'y, WRS-LED, MCC-819-02
413	43162047	Cord clamp

16-2. Outdoor Unit
RAV-SM560AT-E

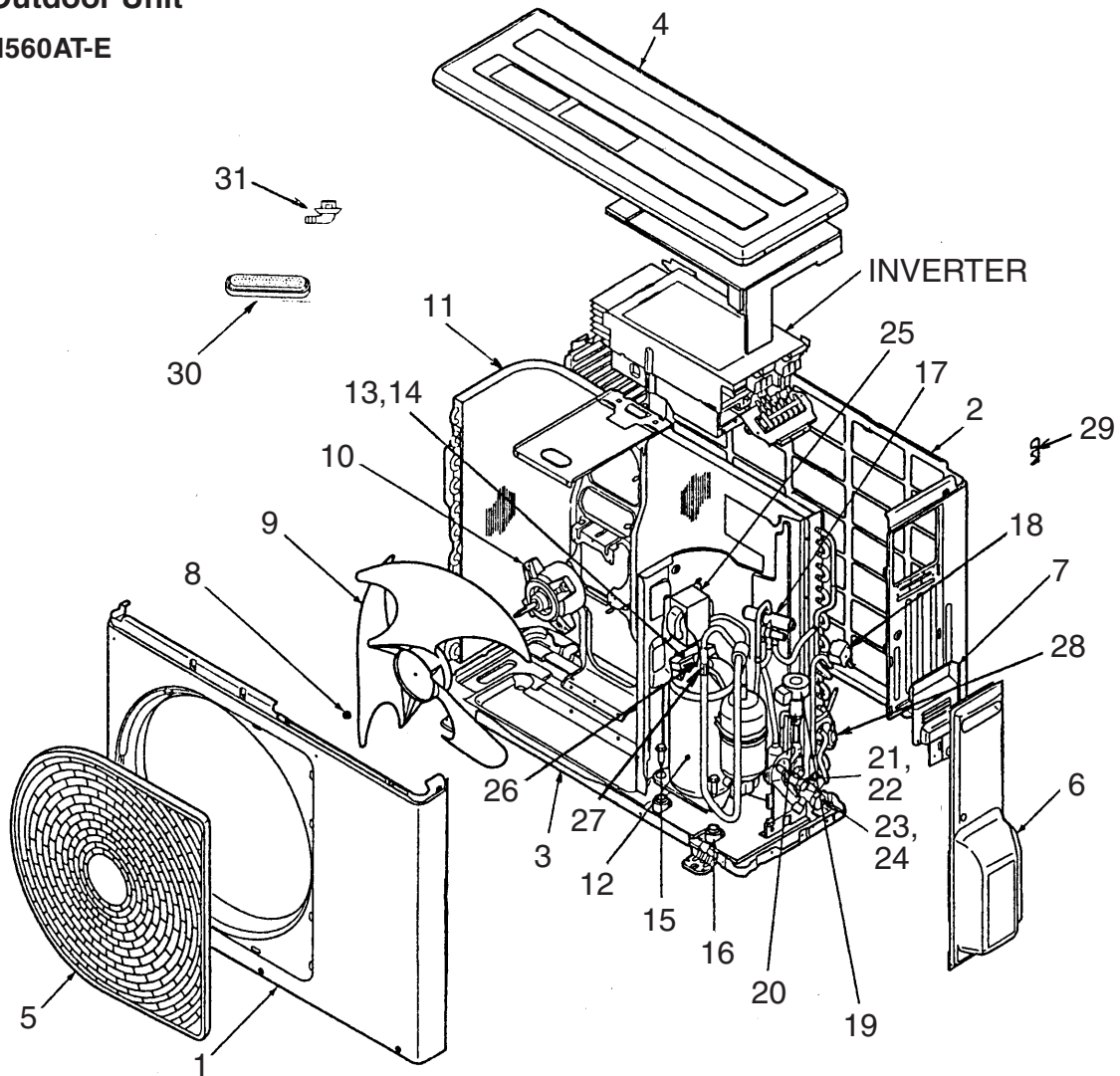

Location No.	Part	Description
1	43105037	Cabinet, Front, PCM
2	43100239	Cabinet, Back, PCM
3	43042468	Base, Ass'y
4	43005508	Cabinet, UP, PCM
5	43119460	Guard, Fan, PP
6	43119448	Cover, Packed, Valve
7	43062230	Cover, Wiring, Ass'y
8	43047667	Nut, Flange
9	43120213	Fan, Propeller, PJ421
10	4302C033	Motor, Fan, ICF-140-43-1
11	4314G128	Condenser, Ass'y
12	43041609	Compressor, DA130A1F-23F
13	43050407	Thermostat, Bimetal
14	43063317	Holder, Thermostat
15	43097206	Bolt, Compressor, M6
16	43049749	Rubber, Cushion
17	43046363	Valve, 4-WAY, VT7101D

Location No.	Part	Description
18	43146617	Solenoid, Coil, LB64045
19	43046385	Valve, Pulse, Modulating, SKV-18D26
20	43046394	Coil, PMV, DKV-MOZS744BO
21	43046392	Valve, Packed, 6.35, AO
22	43147195	Bonnet, 1/2 IN
23	43046393	Valve, Packed, 12.7, HKU-R410A-H4
24	43147196	Bonnet, 1/4 IN, 6.4 CU
25	43055521	Reactor, CH-57
26	43063321	Holder, Sensor, 4-8, 9.52
27	43063322	Holder, Sensor, 6-11.4, 12.7
28	43063325	Holder, Sensor, 6-6.35, 8
29	43063332	Holder, Sensor
30	43089160	Cap, Waterproof
31	43032441	Nipple, Drain

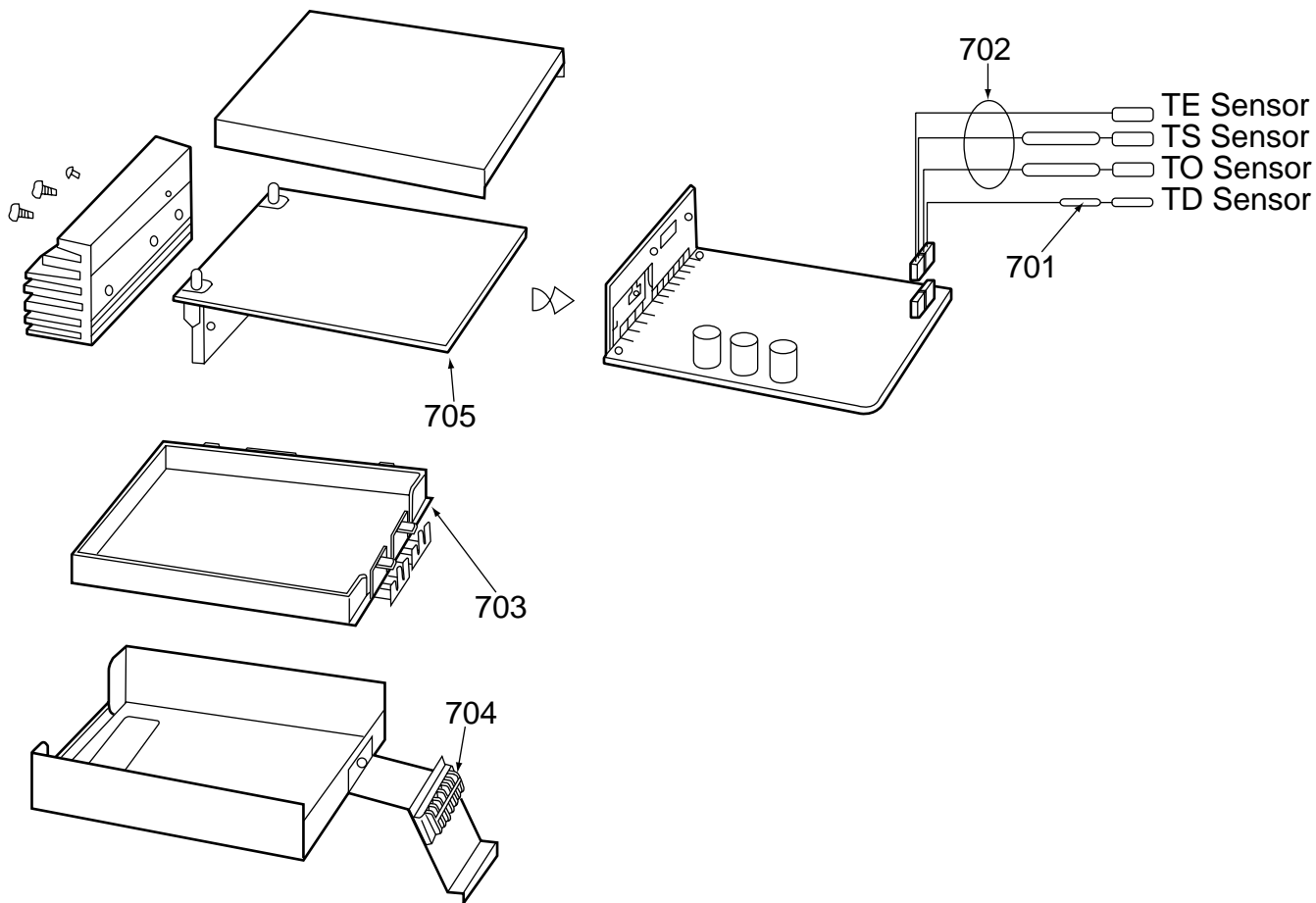

Location No.	Part	Description
701	43050334	Sensor, TD (F4), TD Sensor
702	43050382	Sensor, TC (F6), TC Sensor
703	43062228	Base, P.C. Board, ABS
704	43160469	Terminal Block, 6P, AC250V, 20A
706	4316V182	P.C. Board Ass'y, MCC-813

RAV-SM800AT-E

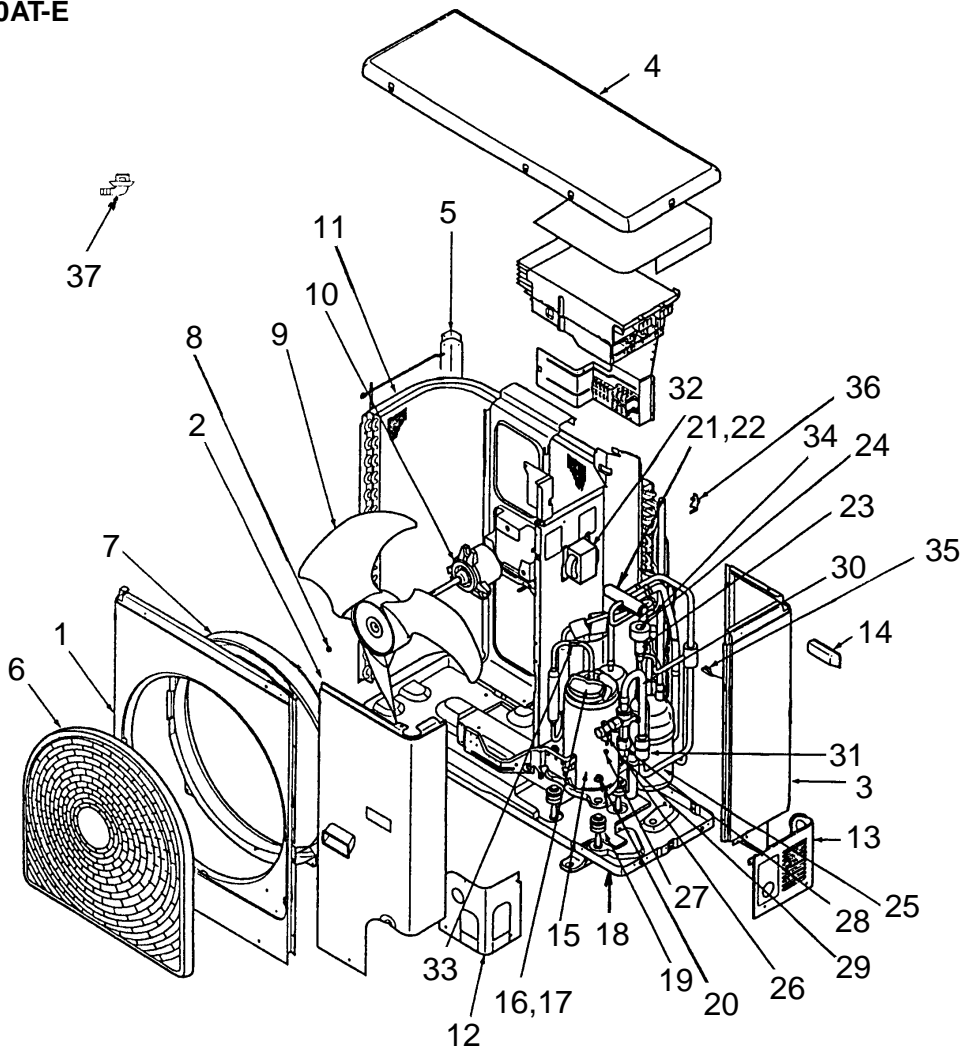

Location No.	Part	Description
1	43191634	Cabinet, Air Outled
2	43191636	Cabinet, Front, Ass'y
3	43191635	Cabinet, Side, Ass'y
4	43191637	Panel, Upper
5	43005489	Guard, Fin
6	43191630	Guard, Fan, PP-K
7	43122065	Bell Mouth, Plastic
8	43047667	Nut, Flange
9	43120123	Fan, Propeller, PJ491, AS-G
10	43121693	Motor, Fan, ICF-140-63-1
11	4314G117	Condenser, Ass'y
12	43191515	Panel, Front, Piping
13	43191605	Panel, Back, Piping
14	43119390	Hanger
15	43041772	Compressor Ass'y
16	43050407	Thermostat, Bimetal
17	43063317	Holder, Thermostat
18	43005482	Base Ass'y
19	43049739	Cushion, Rubber
20	43097204	Nut
21	43046344	Valve, 4-WAY, CHV-0213

Location No.	Part	Description
22	43046348	Coil, Solenoid, VHV-01A150A1
23	43046385	Valve, Pulse, Modulating, SKV-18D26
24	43046386	Coil, PMV, DKV-MO25743BO
25	43048066	Accumulator Ass'y
26	43146584	Valve, Packed, 9.52DIA, HKT9.52
27	43047401	Bonnet, 3/8 IN, 9.52 CU
28	43146613	Valve, Ball, B5/8F
29	43195029	Bonnet
30	43148169	Strainer
31	43148176	Strainer
32	43058266	Reactor, CH-47-Z-K
33	43063321	Holder, Sensor, 4-8, 9.52
34	43063322	Holder, Sensor, 6-11.4, 12.7
35	43063325	Holder, Sensor, 6-6.35, 8
36	43063332	Holder, Sensor
37	43032441	Nipple, Drain

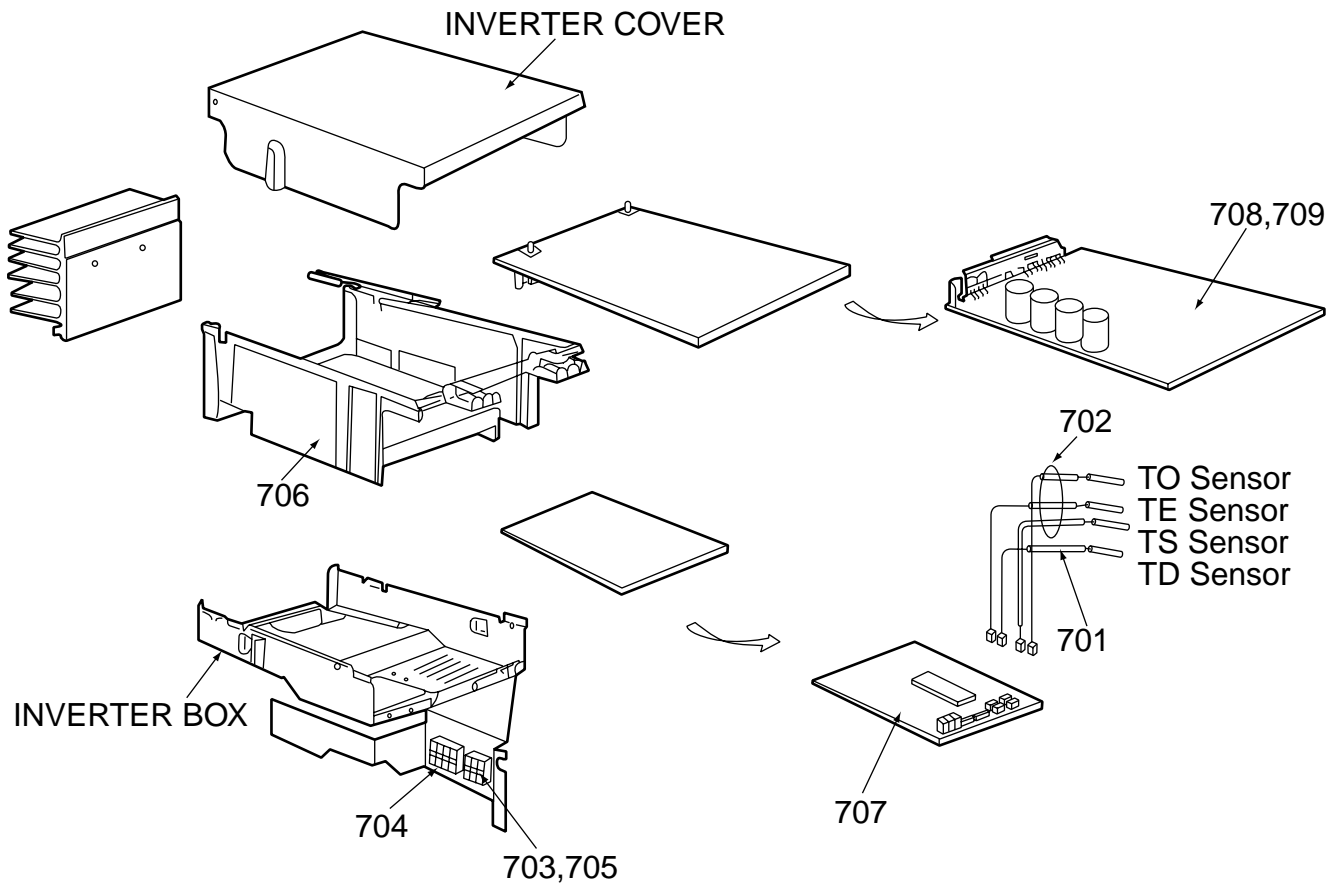

Location No.	Part	Description
701	43050334	Sensor, TD (F4), TD Sensor
702	43050382	Sensor, TC (F6), TC Sensor
704	43160469	Terminal Block, 6P, AC250V, 20A
705	43162042	Base, P.C. Board, ABS
707	4316V183	P.C. Board Ass'y, CDB, MCC-1398
708	4316V184	P.C. Board Ass'y, IPDU, MCC-1359

RAV-SM560XT-E/RAV-SM800XT-E

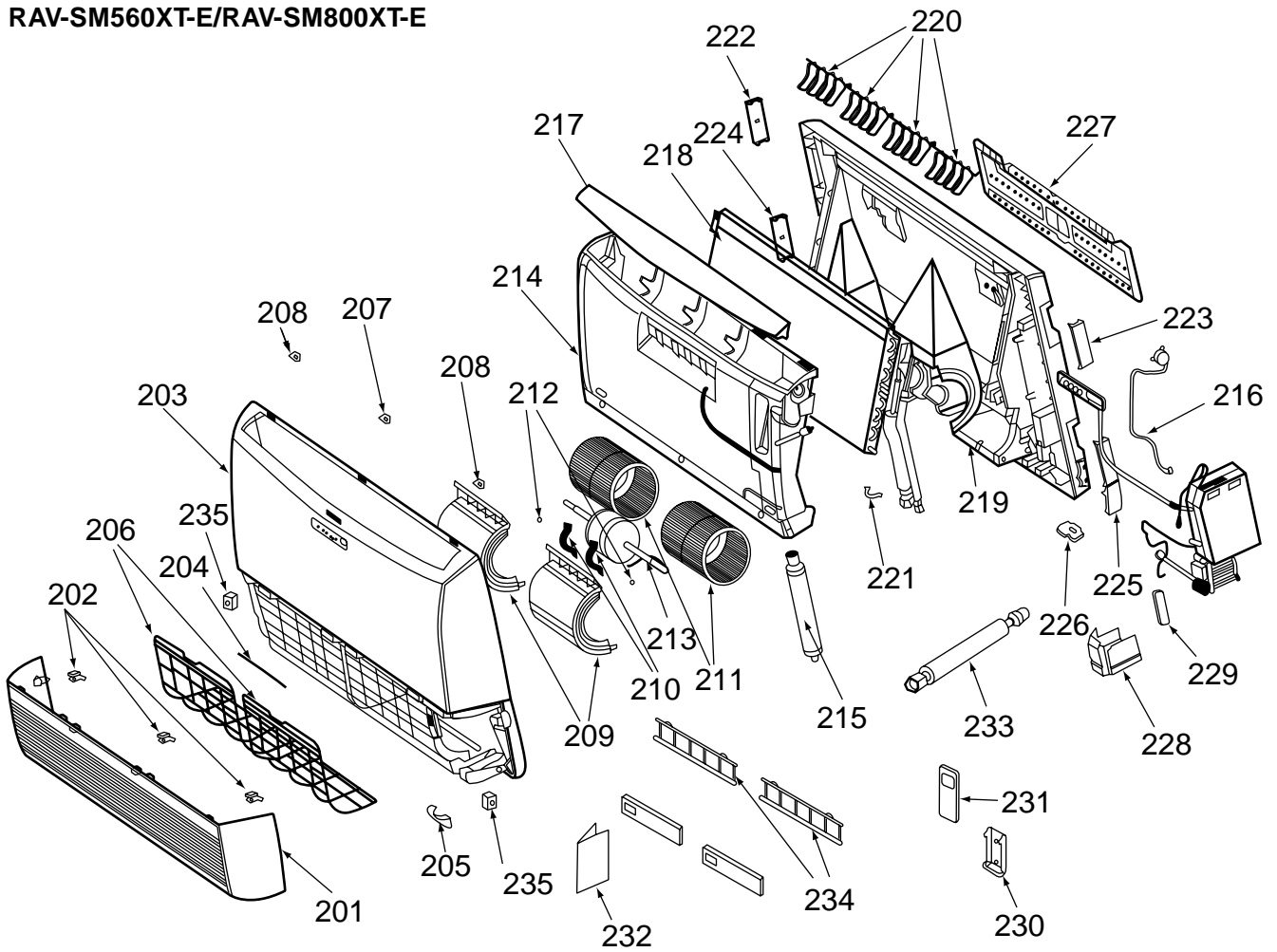

Location No.	Part	Description
201	43T09312	Air Inlet Grille
202	43T00357	Panel Arm Ass'y
203	43T00361	Front Panel Ass'y
203	43T00358	Front Panel Ass'y
204	43T01004	Mark
205	43T79303	Drain Band
206	43T80302	Air Filter
207	43T00359	Cap Screw C
208	43T00360	Cap Screw LR
209	43T20303	Fan Cover
210	43T20304	Motor Band Ass'y
211	43T20305	Multiblade Fan
212	43T19309	Screw Set (D-T)
213	43T21325	Fan Motor
214	43T72301	Drain Pan Ass'y
215	43T79304	Drain Hose Ass'y
216	43T19303	Lover Motor Ass'y
217	43T09313	Horizontal Louver
218	43T44319	Refrigeration Ass'y, Ø12.70
219	43T03303	Back Body Ass'y

Location No.	Part	Description
220	43T09314	Vertical Louver
221	43T49303	Pipe Holder
222	43T19304	Cover Body L
223	43T19305	Cover Body R
224	43T19306	Cover Body LD
225	43T19307	Bush Body R
226	43T19308	Bush Body D
227	43T82302	Installation Plate
228	43T60314	Terminal Cover
229	43T62303	Connector Cover
230	43T83003	Remote Controller Holder
231	43T69309	Wireless Remote Controller
231	43T69310	Wireless Remote Controller
232	43T85335	Owner's Manual
232	43T85336	Owner's Manual
232	43T85337	Owner's Manual
232	43T85341	Owner's Manual
233	43T49304	Flexible pipe, Ø12.70, Ass'y
234	43T80003	Filter Flame
235	43T00365	Grille Stopper Ass'y

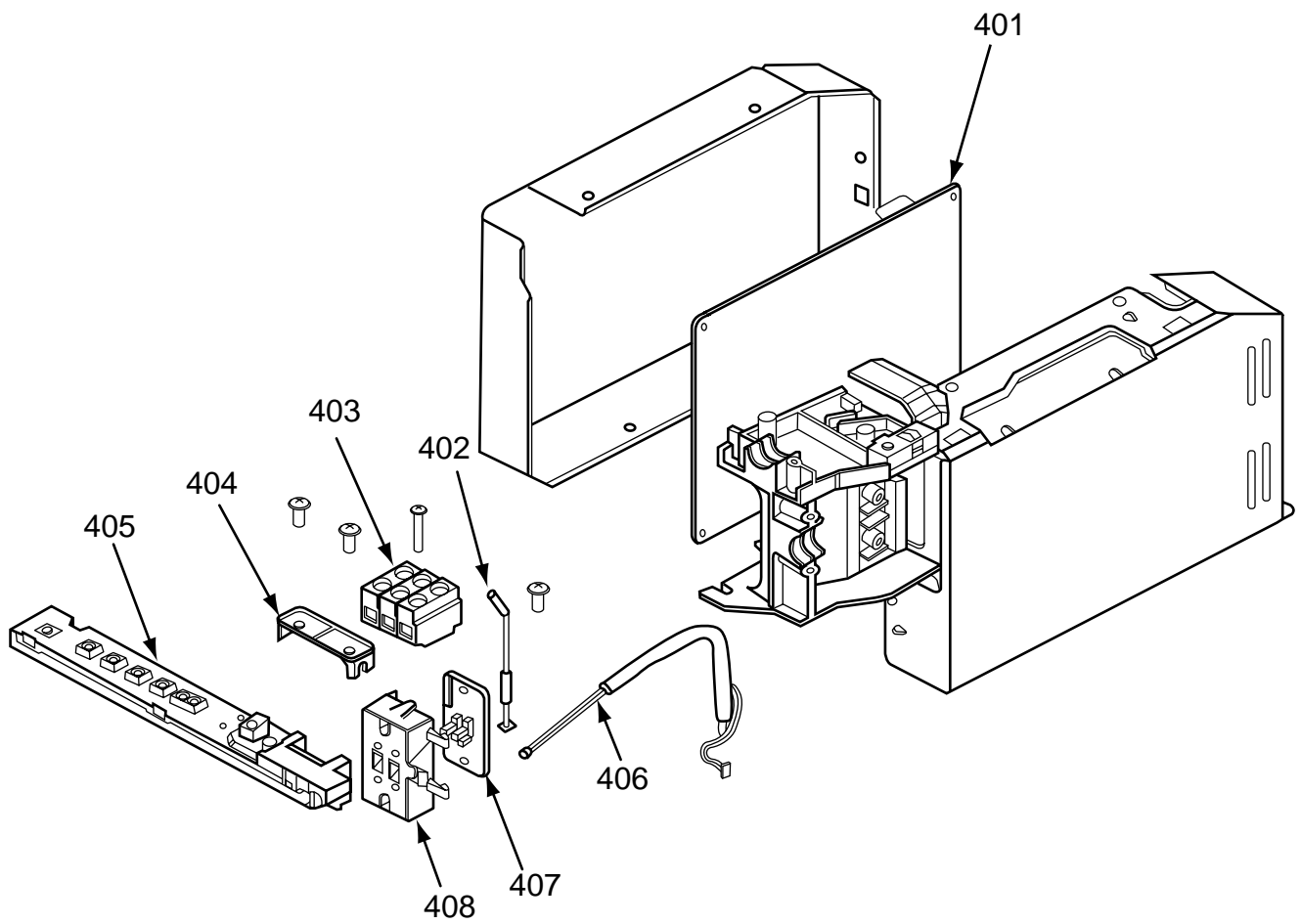

Location No.	Part	Description
401	43T69311	P.C. Board
401	43T69312	P.C. Board
401	43T69313	P.C. Board
401	43T69314	P.C. Board
402	43T50004	Temperature Sensor

CORD HEATER INSTALLATION WORK

Applicable Models: RAV-SM560AT-E, RAV-SM800AT-E

1. Required parts for installation work (Recommendation)

No.	Part name	Q'ty	Specifications/Vendor	Remarks
1	Cord heater	1	Drain line heaters CSC2 (SM560 : 1.5m, 40W/m, SM800 : 2.0m, 40W/m) by Flexelec com. (Please go to the following URL.) http://www.flexelec.com	Procured locally
2	Thermostat	1	US-622AXRLQE by ASAHI KEIKI Operating temperature: on $4 \pm 4^{\circ}\text{C}$, off $15 \pm 3^{\circ}\text{C}$ A thermostat holder is incorporated with a thermostat in the package. (Please go to the following URL.) http://www.asahikeiki.co.jp/product/product.html On self-responsibility, you can use a product manufactured by other company (For example, Texas Instruments) if its characteristics are equivalent to those of ASAHI KEIKI. However, when the shape of the thermostat holder is different from that of ASAHI KEIKI, apply some treatment to No.13 thermostat fixing plate and then fix the holder.	Procured locally
3	Fuse	1	ES3-5000, 250V / 5A by NAGASAWA Electric Co. (Please go to the following URL.) http://www.nagasawa-el.co.jp/ On self-responsibility, you can use a product manufactured by other company if its characteristics are equivalent to those of NAGASAWA Electric Co.	Procured locally
4	Fuse holder	1	GM1H-02 by NAGASAWA Electric Co. (Please go to the following URL.) http://www.nagasawa-el.co.jp/ On self-responsibility, you can use a product manufactured by other company if its characteristics are equivalent to those of NAGASAWA Electric Co.	Procured locally
5	P-shape clamp	16	Use heat-resistance, weatherproof and non-hydrolytic type. Material: 4-fluorinated ethylene copolymer Harness diameter: $\varnothing 7.5$ Use equivalence with the above specifications. 12 pieces are used to fix the cord heater to the outdoor unit base. One piece is used to fix the power cords to the thermostat fixing plate.	Procured locally
6	Screw	15	Self-tapping screw type-B $\varnothing 4 \times 6\text{mm}$, truss head, stainless These screws are used to fix the cord heater to the outdoor unit base with P-shape clamp.	Procured locally
7	Screw	3	Self-tapping screw type-B $\varnothing 4 \times 8\text{mm}$, truss head, stainless Two screws are used to fix the thermostat fixing plate to the back cabinet. One screw is used to fix the power cord to the thermostat fixing plate.	Procured locally
8	Screw	2	Self-tapping screw type-B $\varnothing 3.5 \times 8\text{mm}$, pan head These screws are used to fix the thermostat to the thermostat fixing plate with the thermostat holder.	Procured locally
9	Faston	2	#250 They are used for the connecting part to the thermostat.	Procured locally
10	Sleeve for Faston	2	UL sleeve for #250	Procured locally
11	Close-end connector	2	Use the most appropriate connector with the power cord diameter.	Procured locally
12	Power cord	1	2-cores x 0.75mm^2 or more, H05RN-F	Procured locally
13	Thermostat fixing plate	1	Material: SGCC-Z08, Board thickness: 0.8t	Procured locally (Drawing attached)

NOTE: The parts on the above table are recommended parts.

2. Required tools for installation work

No.	Part name	Specifications	Usage
1	Plus screwdriver		It is used for disassembling and assembling of each cabinet.
2	Wrench		It is used for disassembling and assembling of compressor fixing nuts.
3	Motor drill	Drill diameter: Ø3.2 and Ø5.0	It is used to make the additional holes on the base or the back cabinet.
4	Faston crimping tool	Fixing jig for #250	
5	Close-end connector crimping tool		
6	Cutting plier		
7	Stripper		
8	Cutter knife		
9	Insulation tape		

3. Cord heater installation wiring diagram

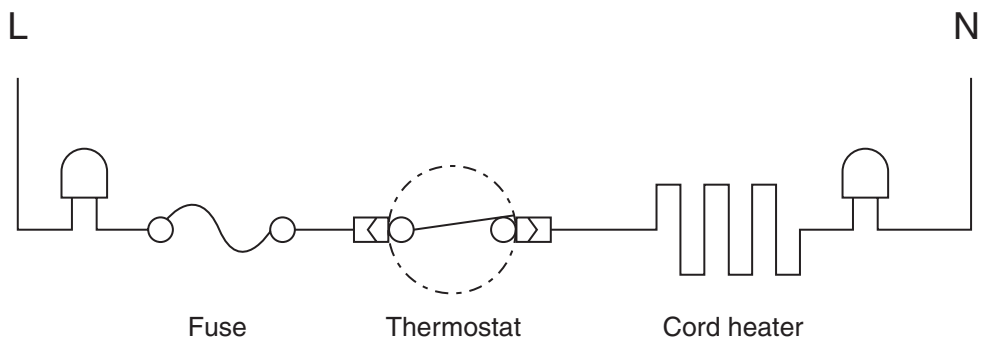

* Be sure to connect the fuse and the thermostat to LIVE side of the cord heater.

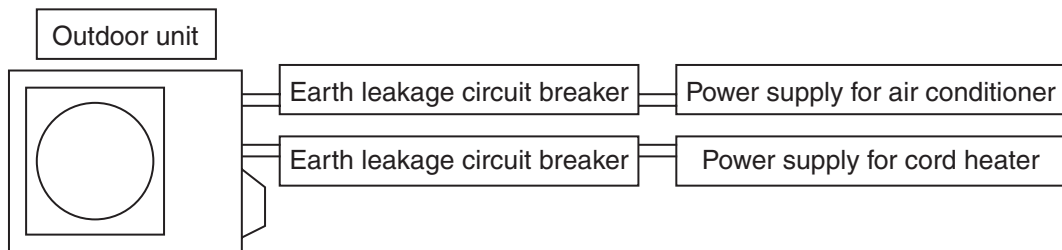





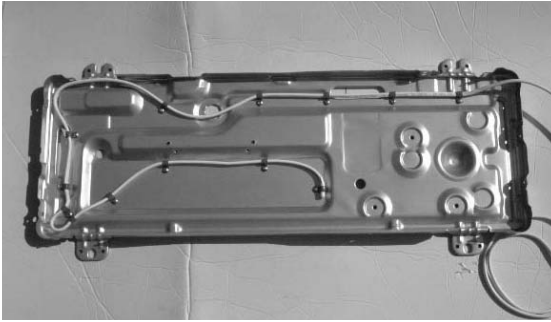

NOTE:

Separate the cord heater power from the air conditioner power, and connect it to its exclusive breaker. By doing so, the power consumption can be decreased because the breaker can be turned off if there is no possibility of freezing of the base in cooling operation, etc.

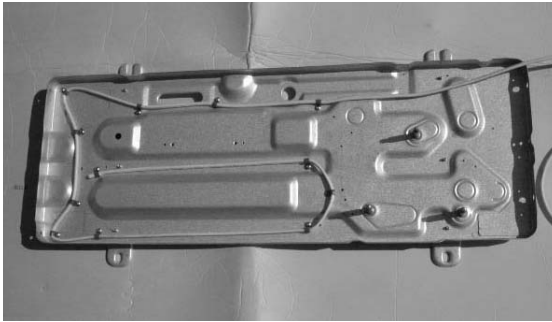
When the cord heater power is connected to the inverter P.C. board assembly or others without connected to the exclusive breaker, the control P.C. board of the inverter assembly may cause a failure.

4. Cord heater installation work procedure

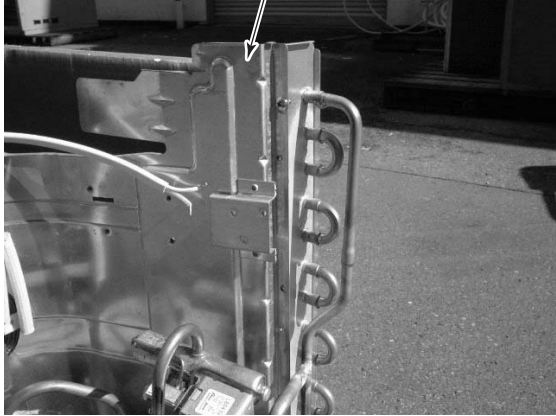
No.	Photo / Explanatory diagram	Procedure
1		Remove each cabinet, inverter assembly, motor base assembly, and partition board assembly. * Do not damage the electric parts such as cables, connectors, etc. while this work.
1-2	<p style="text-align: center;"><Example for RAS-13JAVP-E></p> 	As shown in the left figure, remove the set of refrigeration cycle assembly from the outdoor unit base. * In this time, work attentively so that the cycle pipes are not damaged by dent or deformation. Apply protective measures to pipes if necessary.
2		Cord heater installation work Drill a hole on the outdoor unit base, and fix the cord heater to the outdoor unit base using P-shape clamp. Connect the cord heater cables.
2-1		Using a motor drill, etc., drill Ø3.2 holes to the existing emboss on the outdoor unit base. (12 positions)
2-2	<p style="text-align: center;"><RAV-SM560AT-E></p>    <p style="text-align: center;"><RAV-SM800AT-E></p>   	<p>As shown in the below figure, install the cord heater to the outdoor unit base by using P-shape clamp and screws (Self-tapping screw type-B Ø4 × 6mm, stainless).</p> <p>Pay attention to the direction of P-shape clamp so that it is set to the same direction in the left figure.</p> <p>* If the drain port is frozen due to installation status, etc., draw around the cord heater so that the end part of the heater is inserted into the drain port. In this case, add some fixing positions to fix the cord heater surely.</p> <p>* The end part from the marked part of the cord heater heats up. When there is the heating part near the electric parts box, a fire may generate. Be sure to set the heating part on the outdoor unit base at the fan room side or near it. (within 20cm from the outdoor unit base)</p> <p>* Be careful that the cord heater does not hit the fan. Fix the cord heater without any loosening or sag</p>

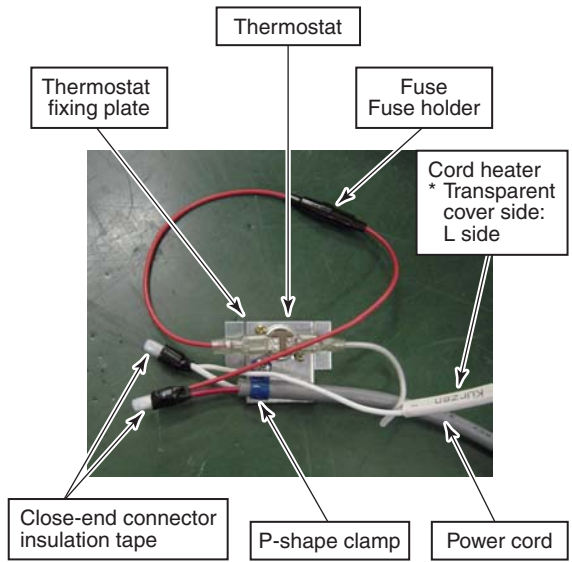
No.	Photo / Explanatory diagram	Procedure
2-3	<p>As shown in the below figure, drill a hole on the partition or back cabinet for fixing the thermostat fixing plate. Ø5 hole at two positions When drilling a hole on the back cabinet, be sure not to damage the cabinet.</p> <div style="display: flex; justify-content: space-around;"> <div style="text-align: center;"> <p><RAV-SM560AT-E></p>  </div> <div style="text-align: center;"> <p><RAV-SM800AT-E></p>  </div> </div>	
2-4		<p>Perform end process and bundling of each cable.</p> <p>Using fixing screws (Self-tapping screw type-B Ø3.5 × 8mm), fix the thermostat to the thermostat fixing plate.</p> <p>Perform end process for various lead cables and connect them according to the wiring diagram.</p> <p>Attach #250 Faston and UL-approved sleeves each to the end of lead cables which are connected to the thermostat.</p> <p>Using insulation tape, apply protective measures to the connected parts by the close-end connectors.</p> <p>Using P-shape clamp and the screws (Self-tapping screw type-B Ø4 × 8mm), fix the power cord to the thermostat fixing plate.</p> <p>When the power cord size does not match with P-shape clamp, procure the most appropriate one at the local site.</p>
3	<p>Assembly</p> <p>Return a set of the refrigeration cycle assembly into the outdoor unit base and reassemble sound insulation board, partition plate assembly, fan motor assembly, and back cabinet as original. Fix the thermostat fixing plate to the back cabinet, built in the inverter assembly, and then connect various cables. After then, incorporate front cabinet, upper cabinet, wiring cover, and valve cover as before.</p>	
4	<p>In installation work, connect power cord for the cord heater to another breaker separated from one for power cord of the air conditioner.</p>	

5. Drawing of thermostat fixing plate

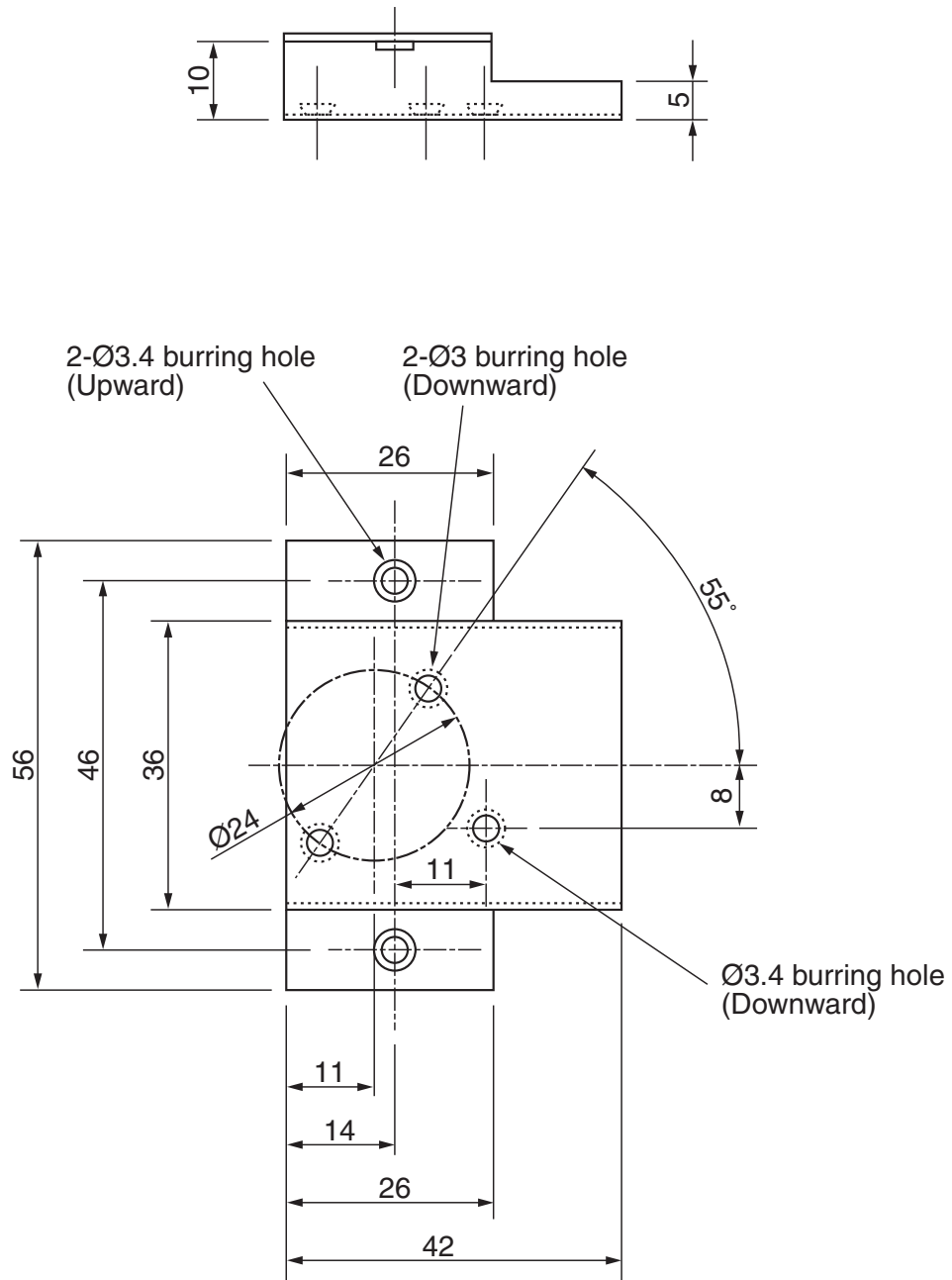

Material: SGCC-Z08, Thickness: 0.8t

TOSHIBA CARRIER CORPORATION

2 CHOME 12-32, KONAN, MINATOKU, TOKYO, 108-0075, JAPAN