

**I N F O**



INSTALLATION AND INSTRUCTION MANUAL  
UPRIGHT FREEZER EU 1420 T

 **Electrolux**

---

# CONTENTS

---

Important user information . . . . .	page 3
About your freezer . . . . .	page 5
Connecting to the mains . . . . .	page 6
Changing over the door hinges . . . . .	page 7
Installing under a worktop . . . . .	page 8
Setting the controls . . . . .	page 9
Using the freezer . . . . .	page 10
Thawing food . . . . .	page 10
Freezing fresh food . . . . .	page 11
Freezing foodstuffs – Individual characteristics . . . . .	page 13
The ice store . . . . .	page 16
Looking after your freezer . . . . .	page 17
Something not working . . . . .	page 18
Electrolux Service Centres . . . . .	page 19
Guarantee . . . . .	page 21

---

# IMPORTANT USER INFORMATION

---



## **IMPORTANT PLEASE READ THE INSTRUCTION BOOK BEFORE USING THIS APPLIANCE**

**It is most important that this instruction book should be retained with the appliance for future reference. Should the appliance be sold or transferred to another owner, or should you move house and leave the appliance, always ensure that the book is supplied with the appliance in order that the new owner can be acquainted with the functioning of the appliance and the relevant warnings.**

**These warnings are provided in the interest of safety. You must read them carefully before installing or using the appliance.**

- This product is designed to be operated by adults. Children should not be allowed to tamper with the controls or play with the product.
  - Any electrical work required to install this appliance should be carried out by a qualified electrician.
  - This product should be serviced by an authorised Electrolux Service Engineer and only genuine Electrolux spare parts should be used.
  - It is dangerous to alter the specifications or modify this product in any way.
  - Care must be taken to ensure that the appliance does not stand on the electrical supply cable.
  - Electrolux domestic freezers are designed to be used specifically for the storage of edible foodstuffs only.
  - There are working parts in this product which heat up. Always ensure that there is adequate ventilation as a failure to do this will result in component failure and possible food loss. See installation instructions.
  - Parts which heat up should not be exposed. Wherever possible the back of the product should be close to a wall but leaving the required distance for ventilation as stated in the installation instructions.
  - Before defrosting, cleaning or maintenance work is carried out, be sure to switch off the appliance and unplug it.
  - The aluminium lining or refrigerated freezer shelves in this appliance contain channels through which the refrigerant passes. If these are punctured this would cause substantial damage to the appliance and result in food loss. **DO NOT USE SHARP INSTRUMENTS** to scrape off frost or ice. Under no circumstances should solid ice be forced off the lining or shelves. Solid ice should be allowed to thaw when defrosting the appliance. See defrost instructions.
  - The appliance should be left for 2 hours after installation before it is turned on in order to allow refrigerant to settle.
- This appliance is heavy. Care should be taken when moving it.
  - Ice lollies can cause frost burns if consumed straight from the freezer.
  - Frozen food must not be refrozen once it has thawed out.
  - Manufacturers' food storage recommendations should be strictly adhered to. Refer to relevant instructions.
  - Do not place carbonated or fizzy drinks in the freezer as it creates pressure on the container which may cause it to explode resulting in damage to the appliance.
  - Under no circumstances should you attempt to repair the appliance yourself. Repairs carried out by inexperienced persons may cause injury or more serious malfunctioning. Refer to your local Electrolux Service Centre and always insist on genuine Electrolux spare parts.

Your new Electrolux freezer will store frozen food and freeze fresh food and is an ideal companion for a matching Electrolux ER 1720 T larder refrigerator.

For best results, it's important that you read all the contents of this handbook before you use your freezer.

At first you may be aware of sounds in your kitchen which you are not used to, particularly if your freezer is against sound-reflective surfaces such as tiled or painted walls. Please remember the cooling units include precision-built components which, like those in car engines and other machinery with fast moving parts, need a running-in period which may last for several weeks. During this period, don't worry — just allow the appliance time to settle down.

Before using your freezer, we advise you to wash the inside and fittings as described on page 17 under "cleaning".

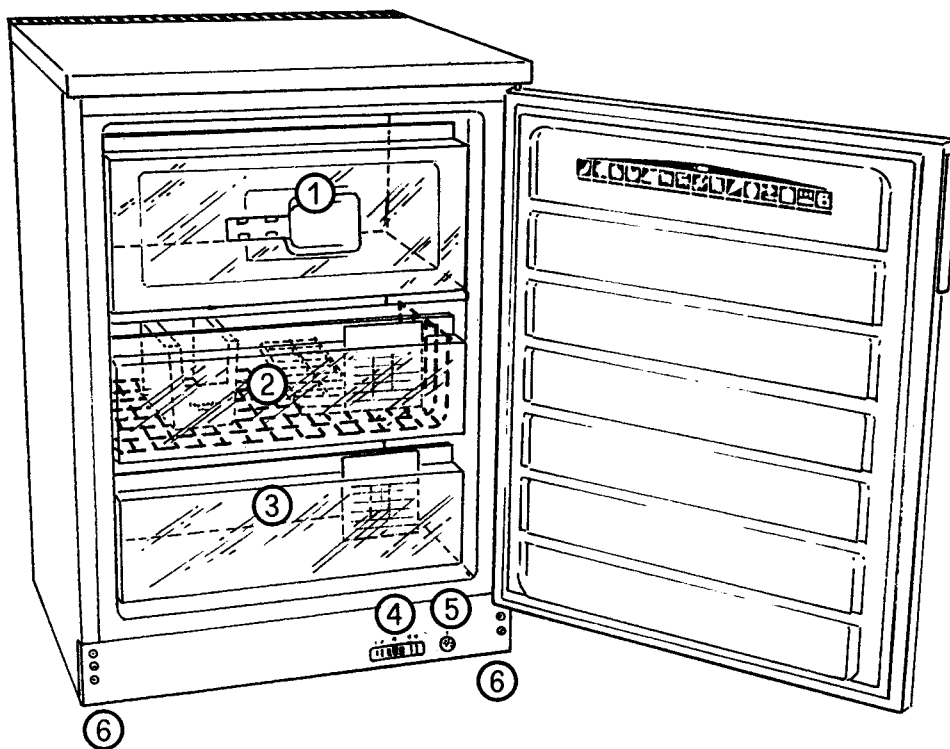

1 Freezing/storage compartment  
2 Pull-out storage basket

3 Storage compartment (lift flap to open)  
4 Indicator lights and switches

5 Thermostat dial  
6 Level adjusters

#### **SAFETY NOTE**

If this appliance is replacing an old one which is going to be scrapped, remove the door before disposal to prevent children from being trapped inside.

---

# ABOUT YOUR FREEZER

---

## Door hang

The chosen position may make it preferable to change over the hinges and door handles to reverse the door hang. To do this refer to "Changing over the door hinges" on page 7.

## Decor panel

If preferred, you can fit a decor panel to the door to harmonise with other furnishings in your kitchen. Instructions for doing this are given on page 7.

## Where to install

For the cooling units to work efficiently, your freezer should be located in a dry atmosphere, out of direct sunlight and away from extreme temperatures, e.g. not next to a cooker or other sources of direct heat, or in a very cold room e.g. an outhouse, where the temperature may fall below 6°C (43°F).

Leave a clearance of at least 50mm (2ins) above the freezer and don't obstruct the space underneath. The back may be placed close to the wall but should not touch it. Do not install in a small pantry or in other places with restricted ventilation.

If your freezer is to be placed under a worktop or built into a kitchen unit, please refer to the instructions given on page 8.

Your freezer will be heavy when loaded with food and must therefore be stood on a strong firm floor. It should also be level. Adjustable feet are provided at the front corners of the cabinet for adjusting the level – see illustration.

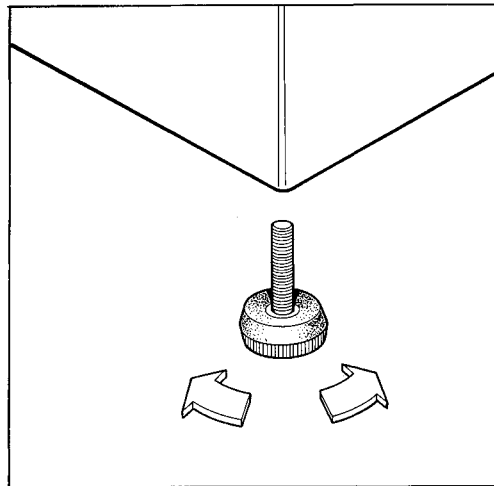

**Make sure the freezer is standing upright and the adjusters are in firm contact with the floor so that the cabinet does not rock in any direction.**

## Connecting to the mains

Before you use your freezer, check that the voltage shown on the data label inside the cabinet conforms with your mains supply.

The mains lead of the freezer is fitted with a non-rewireable moulded-on 13amp plug containing a 13amp fuse. If the fuse requires replacing at any time, the fuse cover/carrier should be removed using a small screwdriver to lever it out. The old fuse should be replaced by a 13 amp ASTA approved BS1362 fuse and the fuse cover/carrier **must** be refitted before the plug is used again. If the fuse cover/carrier is lost, a replacement can be obtained from the Electrolux Service Shops and offices listed on page 19.

The fuse cover/carrier must be of the same colour as that of the coloured insert in the base of the plug.

**In no circumstances must the plug be used without a correct fuse cover/carrier fitted.**

If the plug supplied on the freezer mains lead is not suitable for the socket outlet in your home, it should be cut off and disposed of safely, or destroyed, to avoid any possible shock hazard resulting from the plug being inserted into a 13 amp socket elsewhere in the house. A suitable replacement plug should then be fitted as given below. (If a 13 amp plug and socket are not used, the circuit supplying the freezer should contain a 10 amp fuse).

### WARNING

**THIS APPLIANCE MUST BE EARTHED.**

### IMPORTANT

The wires in the mains lead of this appliance are coloured in accordance with the following code:

**GREEN-and-YELLOW: EARTH**  
**BLUE: NEUTRAL**  
**BROWN: LIVE**

As the colours of the wires in the mains lead may not correspond with the coloured markings identifying the terminals in your plug, proceed as follows:

Connect the GREEN-and-YELLOW coloured wire to the plug terminal marked letter E or earth symbol  $\perp$  or coloured green or green-and-yellow. Connect the BLUE coloured wire to the plug terminal marked letter N or coloured black. Connect the BROWN coloured wire to the plug terminal marked letter L or coloured red.

If at any time a replacement mains lead is required, the cross sectional area of its conductors must not be less than 0.75 mm<sup>2</sup>.

The cover of the terminal box can be removed to gain access to the mains lead terminals after releasing the two clips with a small screwdriver, **but remember to first disconnect the plug from the electricity supply socket.**

**However, we recommend that this operation be carried out by a member of the Electrolux Service Organisation or a qualified electrician.**

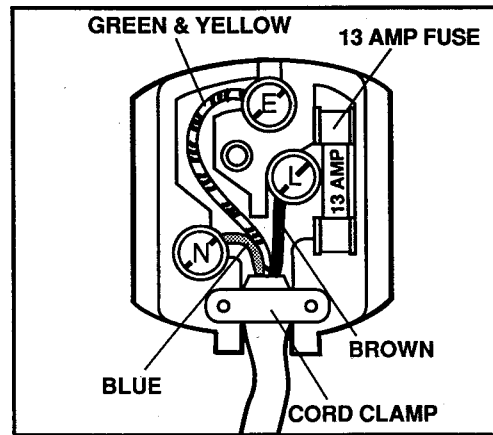

**This appliance complies with EEC directive number 87/308 of 2/6/87 relative to radio interference suppression.**

## As a general guide to fitting any plug

Ensure the lengths of wire inside the plug are prepared correctly.

Connections should be firmly made after all conductor strands are entered into the terminal posts.

When preparing the cable ends take care not to damage the outer sheath, or the insulation surrounding the inner conductors.

Tighten all screws.

Replace the top cover of the plug and secure.

## Extension cord

If using an extension cord at any time always ensure that the insulation sheath is in good condition and is not damaged in any way.

Make sure that the socket is fitted to the extension cable correctly. If in doubt, have it checked by a qualified electrician.

## Door hang and decor panel

### Changing over the door hinges

To enable you to carry out the above operation, you will require the following tools:

Phillips screwdriver

12 mm spanner

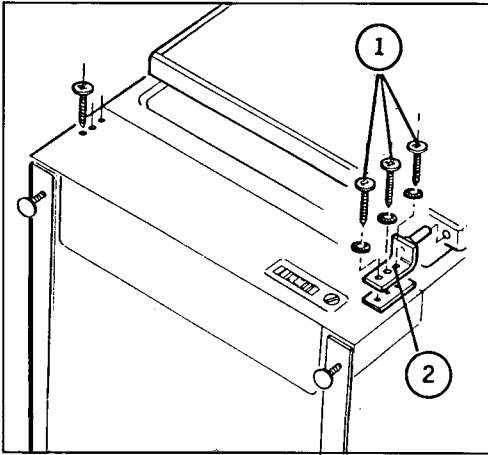

Proceed as follows:

1. If the freezer is already in use, disconnect it from the electricity supply. Remove loose items and temporarily store frozen food in boxes wrapped in blankets or other insulating material. Put these boxes in a cool place.

2. Gently lay the freezer on its back. Using the Phillips screwdriver, remove the lower hinge (2), which is held by 3 screws and shakeproof washers (1). Separate the shakeproof washers from the screws. Refit the screws in the holes in the cabinet. Keep the shakeproof washers and any packaging pieces (from behind the hinge) for re-use on the other side of the cabinet.

3. Remove the door by lifting it at the bottom until it clears the cabinet, then carefully disengaging the top from the upper hinge.

4. Using the 12 mm spanner, unscrew the upper hinge pin and fit it to the outer threaded hole in the hinge bracket on the opposite side.

**At this stage we recommend that reversal of the freezing compartment door is carried out – see next section concerning this.**

5. Refit the freezer door, engaging the top with the hinge pin in its new position.

6. Remove the 3 screws from the base of the cabinet (where the lower hinge is to be located).

7. Fit the lower hinge (2) to the cabinet in its new position. Place any packing pieces (previously removed) behind the hinge. Fit the shakeproof washers to the screws and secure the lower hinge.

8. Remove the 2 blanking screws from the frame of the freezer.

9. Take off the handle cover (see picture). Remove the 2 retaining screws and transfer the handle to the opposite side of the door frame.

10. Refit the blanking screws in the vacant holes.

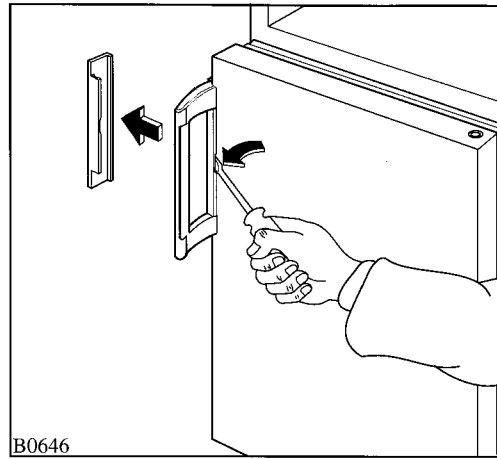

11. Stand the freezer upright and test for satisfactory door opening and closure.

12. Replace all items, re-connect to the electricity supply and then re-load your food.

### Reversal of freezing compartment door

For convenience in use, if the main door hang is reversed, it is advisable to also reverse the freezing compartment door. This is best done during change-over of the main door (after item 4 in the previous section) while the freezer is on its back and the main door is removed.

1. Hold the freezing compartment door open and remove the screws (3) holding the hinges (4) to the cabinet.

2. Remove the 2 screws (6) securing the door catch (7). Turn the catch upside down and fit to the opposite side of the cabinet.

3. Turn the door with its hinges upside down in relation to its original position. Hold the hinge in place and screw firmly to refit the door to the opposite side of the cabinet.

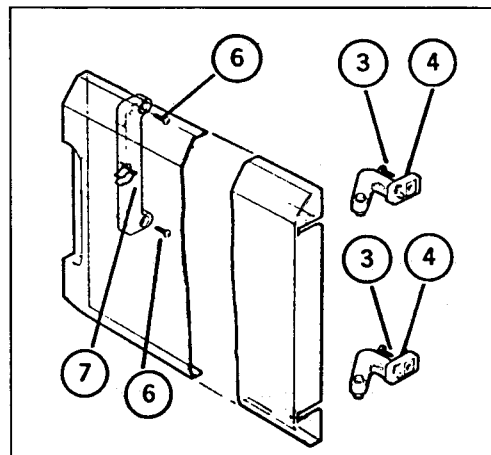

### Fitting a decor panel

The door of the freezer will accept your own decor panel if you wish to fit one to match other equipment in your kitchen. The panel should be 1 to 2 mm less in height and width than the door of the freezer and its thickness should not exceed 3 mm. To fit a decor panel:

1. Pull off the emblem which is stuck to the front of the door.

2. Take off the metal strip from the hinge side of the door by unscrewing all screws. Loosen all screws holding the other strips, including the handle.

3. Slide your decor panel into place, refit the metal strip and tighten all screws, pushing the front of each strip against the panel while doing this to ensure a snug fit.

## Installing under a worktop or building in

### Installing under a work surface

If you are to install your freezer under a work surface or other overhanging structure you can remove the worktop from the freezer to provide more air-flow over the top for satisfactory ventilation of the cooling unit. If you wish you can then fit the ventilation grille supplied to the top front as described in the next section.

Unscrew the two screws (8) securing the rear brackets to the worktop, then slide it out from the slots (9). Remove foot (10) and replace it with the adjustable one contained in the plastic bag together with these instructions.

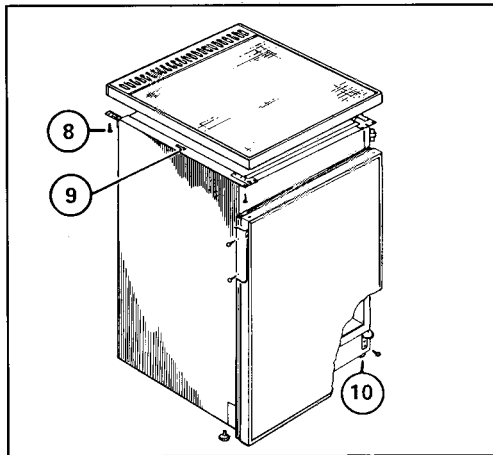

If difficulties arise in building the cabinet in, it may be necessary to remove the two plastic plugs from the support bracket of the compressor.

We suggest you to keep safely the parts removed in case of possible reuse at a later date.

### Building into a kitchen unit

If you wish, you can build your freezer into a kitchen unit. To help with this and make a neat appearance, a ventilation grille is supplied with the freezer for fitting at the top front.

The **minimum** dimensions of the recess to accept the freezer and ventilation grille are as follows (see fig.): Height – 900 mm, width – 600 mm, and depth (front to back) – 600mm.

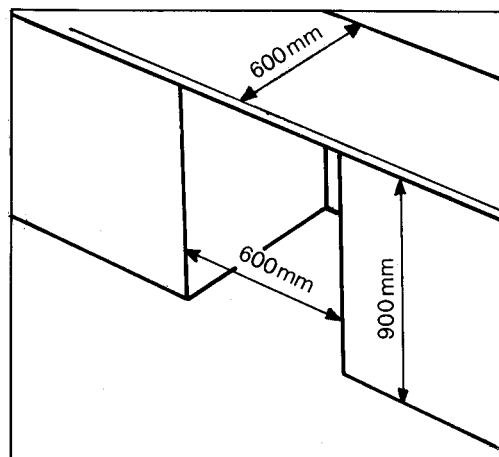

The floor of the recess must be strong enough to safely support the weight of the freezer plus that of the food when fully loaded.

To fit the ventilation grille, first remove the worktop from the freezer as detailed previously under "Installing under a work surface". Then remove the front screw (11) from each of the two hinge brackets (12) on the cabinet. Secure the ventilator clips (13) to the top of the hinge brackets using the new screws supplied, the clips pointing forwards so that they will grip the lower edge of the ventilation grille when it is pushed into place.

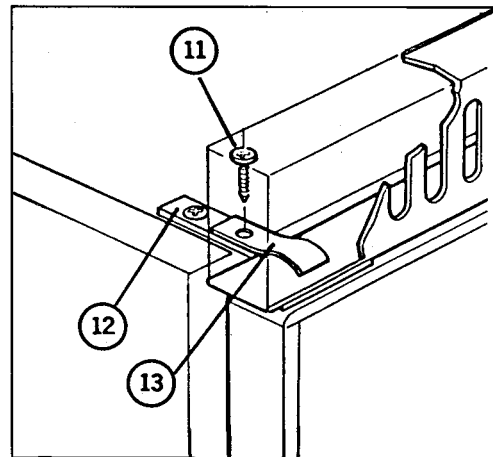

**Important: Free space must be maintained over the freezer for air-flow. Do not block ventilation openings in any way.**

### Adjusting the worktop

The worktop is normally aligned with the freezer door. However, it is adjustable and can be realigned to suit your own needs.

To do this proceed as follows:

1. Remove the two screws (A) securing the worktop at the rear.
2. Push the worktop to the required position and then refit the two fixing screws.

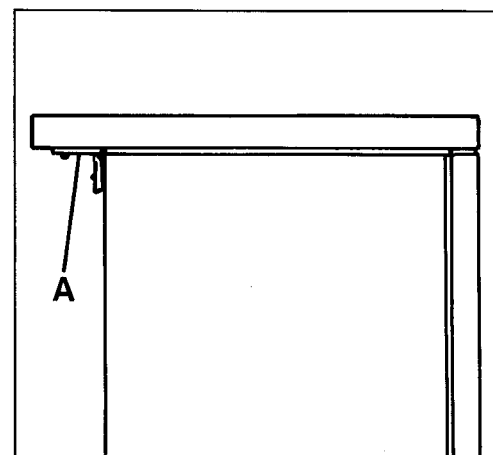



# SETTING THE CONTROLS

The controls for operating the freezer are located at the bottom front — see illustration below.

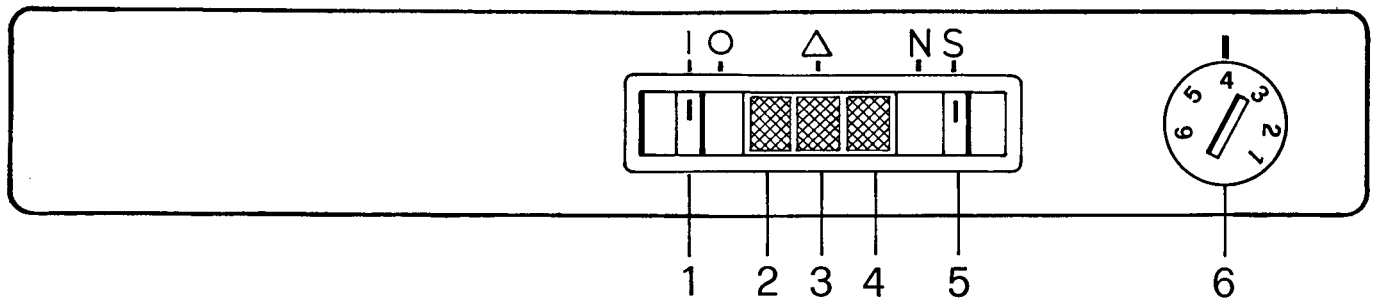

1. On/Off switch. I = ON O = OFF.
2. Green mains-on indicator light.
3. Red temperature warning light.
4. Yellow fast-freeze indicator light.
5. Fast-freeze switch. N = NORMAL S = SUPER.
6. Thermostat dial.

To start the cooling unit, plug into the wall socket and switch the socket on, set the switch (1) to the symbol "I" and turn the thermostat dial (6) to No. 4. The fast-freeze switch (5) should be at "N" (normal). The green mains-on light will come on and the cooling unit will start operating.

The freezer temperature will be affected by location, room temperature and frequency of door opening, and adjustment of the thermostat setting may be needed to allow for this — see under the heading "Temperature control".

When operating, the outside front edges of the freezer may feel warm to the touch. This is quite normal.

**We advise you to run your freezer for a day before storing frozen food.**

## Temperature control

With the thermostat dial set at 4, the temperature will be suitable for the long term storage of frozen food under most conditions of use. In cold weather the dial may be turned to 3 but turn it back to 4 when the weather becomes warmer again.

If colder temperatures are required for some reason, turn the thermostat dial to a **higher** number. The required temperature for long term storage of frozen food is  $-18^{\circ}\text{C}$  ( $0^{\circ}\text{F}$ ) or below.

## Fast-freeze switch and yellow indicator light

The fast-freeze switch overrides the thermostat and should be used when freezing fresh foods as explained later. When the fast-freeze switch is in use (i.e. with the thermostat dial set against "S") the yellow light will come on as a reminder.

## Red temperature warning light

The red light (3) in the control panel will come on as a warning if the temperature in the freezer rises above the level required for the safe storage of frozen food, — provided of course that electricity is still available and that the thermostat is at the correct setting.

The red light will come on when first starting up the freezer and possibly after opening the door, or while freezing fresh food, but it should go out as soon as the temperature falls to the correct level. If it does not, it indicates that something is wrong.

# USING THE FREEZER

The **\*\*\*** symbol means that your freezer will store food at  $-18^{\circ}\text{C}$  ( $0^{\circ}\text{F}$ ) for long term storage and will also freeze fresh food.

## Storing frozen food

Your freezer has the following capacities:

Net Storage Volume		* Weight of Stored Food	
litres	cubic ft	kg	lb
115	4.1	36.8	81

\* This is a standard measurement, the actual capacity depending on the density and sizes of food stored. The above figures are based on an average density of 0.32 kg per litre.

Pre-packed commercially frozen food should be stored in accordance with the manufacturer's instructions for 3 star frozen food compartments and should be put into the freezer as soon as possible after purchase. Your freezer provides for long term storage which generally means up to 3 months but the length of storage time can vary and it is important to follow the recommended times shown on packets of commercially frozen food.

Storage times for home prepared fresh frozen foods are given on pages 13, 14 and 15.

**If your freezer breaks down or the power fails, don't open the door and the frozen food won't be affected for up to 24 hours.**

Any frozen food which thaws accidentally should be eaten as soon as possible or thrown away. Alternatively, if the food is uncooked and it has not completely defrosted, it can be cooked and then refrozen. (Note that some items must be thawed completely before cooking – see next paragraph).

**Cooked food that has defrosted must never be refrozen.**

## Thawing food

### Fruit

Keep container closed and allow to thaw at room temperature for about five hours.

### Vegetables

No thawing needed – place in salted boiling water, cover and time cooking from moment of return to boil. It only takes a few minutes. Can also be put in the oven with a knob of butter. Chips and courgettes can go into hot fat.

### Meat, Poultry etc.

Small jointed items don't require thawing before cooking, but always choose a moderate temperature and allow for a longer cooking time than normal so the meat cooks right through.

However, large items, such as a whole chicken must be thawed first; allow two to three hours per pound at room temperature, then proceed as usual.

### Dairy products

Butter and cream will thaw in one to two hours at room temperature. Egg whites and egg yolks should be placed in closed containers and allowed to thaw. They should be used immediately.

### Baked Items

Bread takes about two hours to thaw or loaves may be heated in the oven. Cakes can be sliced in their frozen state to retain shape and speed the thawing process.

### Prepared Foods

Heat gently in closed containers in the oven.

### Commercial Packs

Simply follow the printed instructions.

---

# FREEZING FRESH FOOD

---

## General information

In any 24 hours you can freeze as much as 15kg (33lb) of fresh food in your freezer. The method to adopt will depend on the weight of food to be frozen at one time:

### 10 to 15kg (22 to 33lb)

Slide the fast-freeze switch to the right so that the indicator mark is against "S" 24 hours **before** loading the food in the freezer; 24 hours after loading the food, return the switch to "N" (normal).

### 5 to 10 kg (11 to 22lb)

Set the fast-freeze switch to "S" as above, but load the fresh food in the freezer **immediately**; 24 hours later, return the switch to "N" (normal).

### Up to 5kg (11lb)

There is no need to use the fast-freeze switch for small quantities, — simply load the food and leave for 24 hours to freeze.

The foods to be frozen should be prepared and packaged as described on the following pages and placed in the freezing compartment as given above, depending on weight. The packages should be in contact with the cooling surface as far as possible and spaced apart to allow cold air to circulate between them. They should not touch existing frozen food packages.

No harm will result if you forget to return the fast-freeze switch to "N" after it has been in use but, for reasons of economy, try to remember to return it when freezing is complete, — the yellow light should remind you of this.

If there is room, you can transfer the food you have frozen to other parts of the freezer allowing you to freeze a further load in the freezing compartment.

For safety reasons, the wire basket is fitted with stops but it can be removed by pulling it forward and lifting it at the front. Refit by reversing this procedure to engage the runners.

## Practical Hints

Different foods need different methods of preparation and some will keep longer than others.

Of course, you can freeze practically anything, but don't waste space in your cabinet by storing foods which are readily available throughout the year.

Fruit is ideal — especially the softer varieties. But avoid pears because they lose their texture and discolour, and bananas, which will turn black.

Vegetables and herbs too are ideal, but salad vegetables and marrows are unsuitable because they contain too much water. Celery loses its crispness, so should be cooked first, and tomatoes are best frozen as purée. Onions should be chopped fine and frozen in small quantities.

All poultry, meat and fresh fish freeze well, as do baked goods, though for shorter periods.

As for prepared foods, these too can be frozen with confidence, but there are a few points to bear in mind.

Semi-liquid foods have a tendency to thicken, so should be made up a little slacker than normal. Highly spiced and aromatic dishes should be wrapped really thoroughly, so the flavour doesn't spread to your other frozen foods. Always cool them quickly and then freeze immediately.

## General Preparation

For freezing purposes always choose the finest quality fresh foods.

### Fruit & Vegetables

Fruit and vegetables should preferably be frozen immediately after harvesting or at least kept in a refrigerator for no longer than twenty-four hours. For perfect results fruit should be **just** ripe, and if any shows signs of being damaged it should be discarded. Most vegetables and some fruit need to be blanched before freezing to retard enzyme reaction. Timings for individual types are given in the detailed tables that appear later in this booklet (pages 13 and 14).

### Meat

Freeze joints in handy-sizes after removing waste such as bones, fat and so forth. Game must be hung for the desired period and cleaned **before** being frozen.

### Fish

Should preferably be frozen within twenty-four hours of being caught. Any superfluous scale should be removed along with the fins, then the fish gutted and washed clean in cold salted water before being frozen.

## Poultry

Gut, singe and wash birds thoroughly. Tie legs and wings to the body before placing in the freezer, or cut into joints for packing separately – giblets should be packed separately, where possible.

## Dairy Products & Baked Items

See individual details in tables which appear later in this booklet (pages 14 and 15).

## Prepared Foods

These freeze well, but remember that seasonings will become intensified during frozen storage, so be very sparing and add whatever you like when ready for eating. Salt actually shortens the storage time for all types of frozen foods, so add only a little during preparation.

## Blanching

Where necessary, (see remarks column on pages 13 and 14), plunge vegetables into boiling water for the specified period, timing from the moment of return to boil. Then drain and cool immediately in cold or iced water before packaging and freezing.

## Packaging

Proper packing is one of the most important points about food freezing, if the true quality is to be preserved.

All food should be carefully wrapped in airtight moistureproof materials. It should be completely covered and as much air as possible shut out to prevent “freezer-burn” – those blemishes which appear on thawing.

The majority of materials you are likely to require will be readily obtainable from your own home freezer supplier, the larger stationery shops and department stores. Most useful are heavy gauge polythene bags or sheeting and plastic containers with tight-fitting lids – also the thicker kinds of aluminium foil.

As far as possible try to pack food in even shapes and sizes to maximise the space available in your freezer cabinet and facilitate removal when required at a later date.

## Labelling

The self-adhesive type of label is probably the most useful as it can be used on every kind of surface. Each label should show clearly what kind of food is in the package, its approximate weight or likely number of servings, the date of initial storage and any comments relevant to ultimate use.

In addition, keep a notebook handy to enable you to rotate your stocks and check your family’s requirements on a daily basis for future reference, so you can plan your household budget accordingly.

## Important points to remember

### DO...

adjust the level of your freezer before loading it with food, – see page 5.

keep a simple record of what you are storing, and remember to rotate stocks, – date markings will help with this.

disconnect from the wall socket and leave the door ajar when the freezer is not in use.

### DON'T...

put hot food in the freezer.

put bottles or cans of fizzy drinks in the freezer.

give children iced lollies straight from the freezer, – they could cause frost burns.

attempt to freeze more than the maximum stated quantity of food in any 24 hours.

obstruct the air-flow under or over the freezer.

use a sharp instrument to remove frost as this could damage the cooling unit.

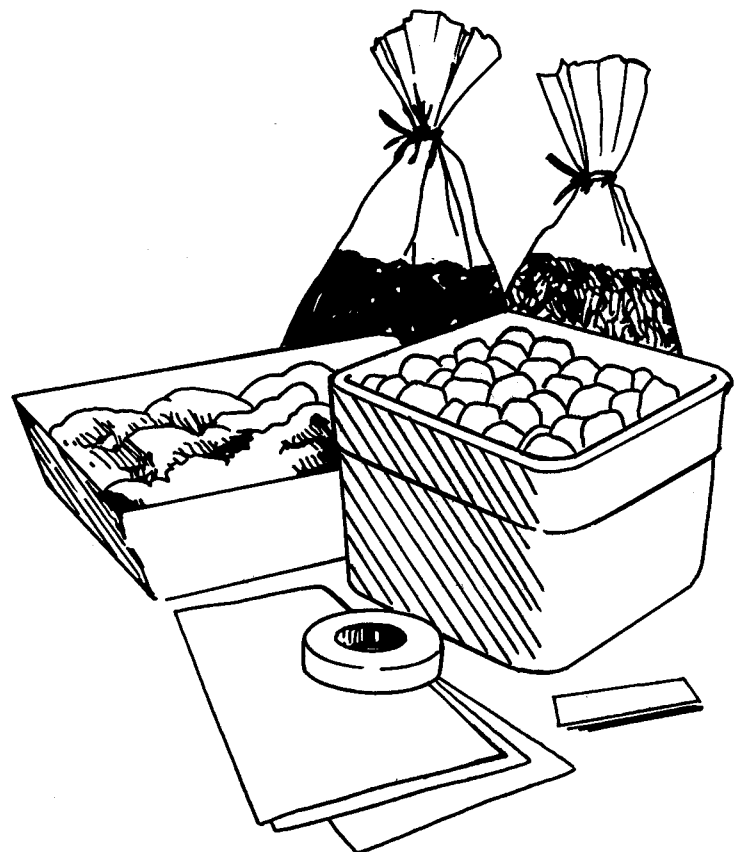

# FREEZING FOODSTUFFS – INDIVIDUAL CHARACTERISTICS

	Max. Storage Period	Method	Remarks
<b>MEAT joints</b>			
Beef	10-12 months	Cut to handy size. Wrap thoroughly	
Pork	6-9 months	Cut to handy size. Wrap thoroughly	
Lamb	9-12 months	Cut to handy size. Wrap thoroughly	
Offcut Steak	10-12 months	Separate with cellophane layers	
Chops	see Pork or Lamb above	Separate with cellophane layers	Wrap carefully to protect against puncturing by sharp bones
Veal Fillets	6-9 months	Separate with cellophane layers	
Bacon, cured smoked	6 weeks 1 month	Separate with cellophane layers	Pack in handy meal portions
Sausages	6 weeks	Wrap tightly	Pack in handy meal portions
Minced meats	2 months	Wrap tightly	Pack in handy meal portions
Offal and tripe	3 months	Clean thoroughly. Pack in small portions	Make sure it is really fresh
<b>POULTRY</b>			
Chicken	9-12 months	Clean in usual way, joint if necessary	Wrap giblets separately – do not stuff till ready
Turkey	9-12 months	Clean in usual way, joint if necessary	
Duck, Goose	6 months	Clean in usual way, joint if necessary	
Giblets	3 months		Wrap separately from bird
<b>GAME</b>			
All types	6 months	Hang before freezing, prepare as for poultry	Cook immediately after thawing
<b>FISH</b>			
All types	3-6 months	Clean, discard head and tail, wrap separately	Must be fresh
Trout	4 months	Clean, discard head and tail, wrap separately	Must be fresh
Salmon	4 months	Clean, stuff with greaseproof paper for shape retention, or cut into steaks	Must be fresh
<b>VEGETABLES</b>			
Mushrooms	12 months	Wash, dry thoroughly. Freeze loose (or sauted in a little butter till partially cooked, then freeze)	Pack viable quantities in boxes
Potatoes	10-12 months	New potatoes and chips can be frozen raw. Otherwise cook partially in one of usual forms, cool then freeze	
Beans	12 months	Peel or pod, and wash	Blanch for 2 mins., cool for same time in iced water then freeze.

	<b>Max. Storage Period</b>	<b>Method</b>	<b>Remarks</b>
Carrots	12 months	Use small ones. Prepare	Blanch for 5 mins.
Cauliflower	12 months	Break up into florets	Blanch for 3 mins.
Spinach	12 months	Wash thoroughly. Remove thicker veins	Blanch a few leaves at a time, for 2 mins.
Sprouts	12 months	Use only small ones. Remove outer leaves	Blanch for 3 mins.
Root crops	12 months	The younger the better. Peel and slice or freeze whole	Blanch for 3 mins.
<b>FRUIT</b>			
Apples	9-12 months	Freeze either of two ways: As purée-stew with little water, beat to smooth pulp, sweeten to taste, cool. OR Sliced-blanch for two minutes, drain and cool. Pack tightly in layers with a little dry sugar sprinkled between, if so desired; or soak in slightly salted water for ten minutes, dry and freeze	Freeze in small quantities. Pack in plastic containers, leaving 1/2" headroom ditto
Apricots	10-12 months	Preferably remove stones, but leave skins on. Pack in syrup 1/2-1 lb. sugar to 1 pint of water, making sure fruit is covered	Pack in plastic containers, leaving 1/2"-1" headroom
Cherries	12 months	ditto	ditto
Damsons	12 months	ditto	ditto
Plums	9 months	ditto	ditto
Gooseberries	12 months	ditto	ditto
Blackberries	12 months	Either pack in syrup as above, or coat with caster sugar and pack in plastic containers. Also may be frozen loose: spread on trays allowed to freeze overnight and then packed in containers	ditto
Currants	12 months	ditto	ditto
Raspberries	12 months	ditto	ditto
Strawberries	12 months	ditto	ditto
Peaches	10 months	Cover with boiling water for 1 minute, then cool by dipping into cold and peel carefully. Cut into halves, removing stone. Use syrup method of packing and freezing	Keep fruit submerged in syrup; place crumpled greaseproof paper on top, so there is no room between the surface of the liquid and the lid
<b>DAIRY PRODUCTS</b>			
Egg Whites	10 months	Eggs must always be separated. Place whites in small containers just a few at a time	Eggs frozen in their shells will crack
Egg Yolks	10 months	As for whites, but to prevent coagulation mix with 1/2 tsp. salt or 1 tsp. caster sugar to every two yolks	Use for savoury or sweet dishes accordingly

	<b>Max. Storage Period</b>	<b>Method</b>	<b>Remarks</b>
Butter	6 months (unsalted) 3 months (salted)	Wrap bought butter in foil and freeze	
Cream Whipping and Double only	4 months	Must first be beaten lightly before freezing	Allow slight room for expansion in the container
Cheese	8 months (soft) 3 months (hard)	Wrap all varieties tightly in foil	Hard cheese stores much better when grated
<b>BAKED ITEMS Wrap in foil or polythene bags</b>			
Bread (Freshly baked)	1-2 months		
Cakes, plain	6 months	Just wrap and freeze	
Cakes, iced	3 months	Freeze without wrapping, then wrap and store in polythene	
<b>PREPARED FOODS</b>			
Stews	2 months	May be frozen quite satisfactorily in a polythene bag	
Sauces	4 months	Freeze in quantities of ½ pint. A little extra liquid may be required, when you come to use it	Egg based sauces are unsuitable
Full courses	3 months	Assemble individual helpings on specially constructed aluminium trays, then cover with foil. To re-heat leave the cover on and put in the oven for about 45 minutes at 400°F (200°C)	Cover slices of meat with gravy to prevent drying out

---

# THE ICE STORE

---

## Ice making

The freezing compartment includes an ice store which enables you to build up a supply of ice cubes for a forthcoming party or spell of hot weather when ice will be in demand. The ice tray fits in the top of the ice store.

First, make ice cubes by filling the ice tray with fresh drinking water to the top of each ice cube compartment and placing the tray in the top of the ice store in the freezing compartment. For quicker ice-making, you can place the ice tray directly on the floor of the freezing compartment.

When ice cubes have formed, hold the tray upside down over the ice store and twist the tray along its length, allowing the loosened cubes to fall into the store.

Several makings of ice cubes can be accommodated and, of course, you can also leave the ice tray full of cubes, conveniently placed on top of the ice store.



---

# LOOKING AFTER YOUR FREEZER

---

## How to defrost

Frost accumulates on the cooling surfaces during normal working and should occasionally be removed using the plastic scraper supplied (clipped to the inside of the freezing compartment door).

Heavy frosting (about 1/4" thick) will reduce the freezer's efficiency and therefore complete defrosting should then be carried out, probably at 6 month intervals, depending on usage. Preferably you should do this when there is little or no food in the freezer, in the following manner:

**1** Any remaining frozen food should be placed in another freezer, or in cardboard boxes and wrapped in blankets, layers of paper, or other suitable insulating material. Put in a cool place.

**2** Switch off at the wall socket, remove the plug, and leave the freezer door open.

**3** Defrosting can be speeded up by putting bowls of hot (not boiling) water in the freezer and loosening the frost with the plastic scraper supplied.

**4** As defrosting progresses, remove loose frost and ice and soak up defrost water with a sponge or cloth.

**5.** When defrosting has finished, clean and dry the interior as explained later under the heading "Cleaning", re-connect to the electricity supply and switch on. See that the thermostat dial is at the required setting and that the green mains-on indicator light is on. Replace frozen food and close the door.

**REMEMBER**, if the temperature of frozen food is allowed to rise unduly during defrosting, its storage life may be shortened.

## Cleaning

The most suitable time to clean your freezer is after defrosting. Remember to first switch off and pull out the plug.

The interior and fittings should be thoroughly cleaned with a clean cloth wrung out in a solution of one teaspoonful of bicarbonate of soda in each pint of water.

**Never use neat detergents, abrasive powders, highly perfumed cleaning materials or wax polishes to clean the interior as these can damage the surfaces or leave a strong smell.**

The outside should be occasionally dusted or wiped over with a damp cloth and a small amount of detergent. But not the door seal, which should be cleaned only with soap and water and thoroughly dried.

A small amount of wax polish applied every few months will maintain the gloss finish of the outside.

The motor compressor and condenser at the rear should also be cleaned of dust occasionally using a brush, but make sure the freezer is unplugged when you do this.

## Going on holiday

Don't switch off at the mains if you intend to leave food in the freezer.

If you are leaving the freezer empty, switch off at the wall socket and remove the plug. Defrost, clean and dry, **and leave the door open.**

---

# SOMETHING NOT WORKING

---

## **Before you call for a Service Engineer, carry out these simple checks:**

Is the freezer on/off switch "on" i.e. with its indicator mark set against the symbol "I", and is the green light showing? If the green light is not on, check for a power failure by switching on your house lights.

If your house supply is in order, is the freezer plug firmly connected to the wall socket, and is the socket still switched on? Try plugging in a table lamp or other appliance to see if power is available at the particular wall socket.

Is the fuse in the plug intact? If you have fitted your own plug, are the wires of the mains lead correctly connected? (See "Connecting to the mains", on page 6).

Have you turned the thermostat to the correct setting?

Has the door been left open causing the temperature to rise?

Sometimes the freezer door will be difficult to open shortly after you have closed it. Don't worry; this is due to a pressure difference which will quickly equalise and allow the door to open normally.

If, after checking these points, your freezer still won't work, call your nearest Electrolux Service Office without delay. It is listed on pages 19 and 20.

When calling, tell us your name, address with post-code, telephone number and what appears to be wrong, also the Model number of your freezer and when and where you purchased it.

For future reference we suggest you record these details here, and keep the receipt with the handbook as proof of purchase.

Purchased from \_\_\_\_\_

Date of Purchase \_\_\_\_\_

Model Number EU 1420 T \_\_\_\_\_

# Emaco

AFTERSALES

## **ELECTROLUX - TRICITY BENDIX - DISTRIPARTS** **THE MANUFACTURERS SERVICE AND SPARES**

Service Centre	Postcode areas covered	Telephone	Address
ABERDEEN	DD IV KW AB PH	0224 696569	Electrolux - Tricity Bendix Service 8 Cornhill Arcade, Cornhill Drive, Aberdeen AB2 5UT
NORTHERN REGION CENTRE	CA DL DH NE SR TS SK M BL OL BB LA FY PR WN CW CH LL L WA	0325 301400 0282 774621 051 2541724	Electrolux - Tricity Bendix Service PO Box 40 Preston Road, Aycliffe Industrial Estate, Newton Aycliffe, Co. Durham DL5 6XL
BELFAST	BT	0232 746591	Electrolux - Tricity Bendix Service Unit C3, Edenderry Industrial Estate, 326 Crumlin Road, Belfast BT14 7EE
BIRMINGHAM	WR DY B WV TF ST SY WS GL HP NN OX SL RG	021 358 7076 or 021 358 5051 0993-704411	Electrolux - Tricity Bendix Service 8 Lammermoor Ave, Great Barr, Birmingham, B43 6ET
CARDIFF	CF HR LD NP SA	0222 460131	Electrolux - Tricity Bendix Service Guardian Industrial Estate, Clydesmuir Road, Tremorfa, Cardiff, CF2 2QS
GLASGOW	DG KA ML G PA KY EH TD FK	041 647 4381 031 557 8383	Electrolux - Tricity Bendix Service 20 Cunningham Road, Clyde Estate, Rutherglen, Glasgow, G73 1PP
LEEDS	S DN HU YO WF HX HD LS HG BD	0532 608511	Electrolux - Tricity Bendix Service 64-66 Cross Gates Road, Leeds, LS15 7NN
LEICESTER	LE DE CV NG LN PE IP NR	0533 515131	Electrolux - Tricity Bendix Service 10-12 Buckminster Road, Leicester LE3 9AR
	RM CM SS CO IG	0268 694144	
LONDON REGION CENTRE	E EC WC N NW W EN SE SM CR BR SW	081 443 3464 081 658 9069	Electrolux - Tricity Bendix Service 2-4 Sandhurst, Kings Road, Canvey Island SS8 0QY
	AL CB LU MK SG WD HA UB TW	081 965 9699	
SOUTHERN REGION CENTRE	BH DT PO SO SP KT GU BA BS SN TA TQ EX TR PL	0705 667411 0272 211876 0626 65909	Electrolux - Tricity Bendix Service Limberline Road, Hilsea, Portsmouth P03 5JJ
TONBRIDGE	CT DA ME TN BN RH	0732 357722 0273 694341	Electrolux - Tricity Bendix Service 61-63 High Street, Tonbridge, TN9 1SD

# Emaco

AFTERSALES

 **ELECTROLUX - TRICITY BENDIX - DISTRIPARTS**  
**THE MANUFACTURERS SERVICE AND SPARES**

## **Postcode to Service Centre cross - reference**

AB	Aberdeen	GU	Southern Region	PO	Southern Region
AL	London Region	HA	London Region	PR	Northern Region
B	Birmingham	HD	Leeds	RG	Birmingham
BA	Southern Region	HG	Leeds	RH	Tonbridge
BB	Northern Region	HP	Birmingham	RM	London Region
BD	Leeds	HR	Cardiff	S	Leeds
BH	Southern Region	HU	Leeds	SA	Cardiff
BL	Northern Region	HX	Leeds	SE	London Region
BS	Southern Region	IG	London Region	SG	London Region
BT	Belfast	IP	Leicester	SK	Northern Region
BN	Tonbridge	IV	Aberdeen	SL	Birmingham
BR	London Region	KA	Glasgow	SM	London Region
CA	Northern Region	KT	Southern Region	SN	Southern Region
CB	London Region	KW	Aberdeen	SO	Southern Region
CF	Cardiff	KY	Glasgow	SP	Southern Region
CH	Northern Region	L	Northern Region	SR	Northern Region
CM	London Region	LA	Northern Region	ST	Birmingham
CO	London Region	LD	Cardiff	SY	Birmingham
CR	London Region	LE	Leicester	SS	London Region
CT	Tonbridge	LL	Northern Region	SW	London Region
CV	Leicester	LN	Leicester	TA	Southern Region
CW	Northern Region	LS	Leeds	TD	Glasgow
DA	Tonbridge	LU	London Region	TF	Birmingham
DD	Aberdeen	M	Northern Region	TN	Tonbridge
DE	Leicester	ME	Tonbridge	TQ	Southern Region
DG	Glasgow	MK	London Region	TR	Southern Region
DH	Northern Region	ML	Glasgow	TS	Northern Region
DL	Northern Region	N	London Region	TW	London Region
DN	Leeds	NE	Northern Region	UB	London Region
DT	Southern Region	NG	Leicester	W	London Region
DY	Birmingham	NN	Birmingham	WA	Northern Region
E	London Region	NP	Cardiff	WC	London Region
EC	London Region	NR	Leicester	WD	London Region
EH	Glasgow	NW	London Region	WF	Leeds
EN	London Region	OL	Northern Region	WN	Northern Region
EX	Southern Region	OX	Birmingham	WR	Birmingham
FK	Glasgow	PA	Glasgow	WS	Birmingham
FY	Northern Region	PE	Leicester	WV	Birmingham
G	Glasgow	PH	Aberdeen	YO	Leeds
GL	Birmingham	PL	Southern Region		

---

# GUARANTEE

---

**This guarantee is offered to you as an extra benefit and does not affect your legal rights.**

Electrolux products are carefully designed, manufactured, tested and inspected and in consequence we undertake to replace or repair any part found to be defective in material or workmanship, within one year of delivery to the original purchaser, free of charge.

The Company does not accept liability for defects arising from neglect, misuse, or accident.

There are certain conditions which may invalidate this guarantee:

- a) It is dependent upon the appliance being correctly installed and used in accordance with the Company's instructions under normal domestic conditions within the United Kingdom or the Republic of Ireland.
- b) Service at all times must be carried out by an Electrolux service representative or authorised agent.
- c) The guarantee may be invalidated by unauthorised repair or modification of the appliance.

Proof of the date of purchase will be required before service under guarantee is provided. Addresses or telephone numbers for service requests are listed on pages 19 and 20.

We must point out that this guarantee does not cover liability for loss of food or other contents, but would draw your attention to the insurance facilities described on the separate leaflet.





