

# Model 7000

## *Service Manual*



**IMPORTANT: Fill in Pertinent Information on Page 3 for Future Reference**

---

# Table of Contents

---

Job Specification Sheet.....	3
Water Softener Control Valve .....	4
Valve Installation and Start-Up Procedures.....	5
7000 Control Operation and Settings .....	6
Programming a Meter Delayed Regeneration System .....	9
Programming a Meter Immediate Regenerated System .....	11
Programming a Time Clock Regenerated System .....	12
Programming a Day of the Week Regenerated System.....	14
Water Conditioner Flow Diagrams.....	16
Power Head Assembly .....	20
Valve Assembly .....	22
Bypass Assembly .....	24
2310 Safety Brine Valve .....	25
Troubleshooting.....	26
Removing Gear Box Assembly.....	28
Inserting Circuit Board.....	29
Connecting the Circuit Board.....	30
Dimensions.....	31
Meter Flow Data .....	32
Injector Flow Data.....	33

**IMPORTANT:** The information, specifications and illustrations in this manual are based on the latest information available at the time of printing. The manufacturer reserves the right to make changes at any time without notice.



---

# Water Softener Control Valve

---

## Water Pressure

A minimum of 20 psi inlet water pressure is required for regeneration valve to operate effectively.

## Electrical Facilities

An uninterrupted alternating current (A/C) supply is required. Make sure:

- Voltage supply is compatible with unit before installation.
- Current supply is always hot and cannot be turned off with another switch.

## Existing Plumbing

Condition of existing plumbing should be free from lime and iron buildup. Replace piping that has heavy lime and/or iron build-up. If piping is clogged with iron, install a separate iron filter unit ahead of the water softener.

## Location of Softener and Drain

Locate the softener close to a clean working drain and connect according to local plumbing codes.

## Bypass Valves

Always provide for the installation of a bypass valve if unit is not equipped with one.

	<p><b>CAUTION</b></p> <ul style="list-style-type: none"><li>•Minimum water pressure 20psig.</li><li>•Maximum water pressure 125psig.</li><li>•Minimum water temperature 34° F.</li><li>•Maximum water temperature 110° F.</li><li>•Ambient temperature 34° to 122° F (1° to 50° C)</li><li>•Disconnect all power sources before servicing.</li><li>•Always operate with cover in place.</li></ul>
---	---

## NOTE:

This product should be installed by qualified personnel.  
Comply with all plumbing codes when installing this product.  
Comply with all electrical codes when installing this product.

	<p><b>WARNING</b></p> <p>The system <b>MUST</b> be depressurized before removing any quick connections for servicing.</p>
---	---

---

# Valve Installation and Start-Up Procedures

---

## Installation Instructions

1. Place the softener tank where you want to install the unit.  
**NOTE: Be sure the tank is level and on a firm, clean base.**
2. Perform all plumbing according to local plumbing codes.
3. Cut the 1.05" or 32mm distributor tube flush with the top of the tank (A).
  - Deburr the outside of the tube (B) after cutting.
  - Lubricate the o-ring (C) with non-petroleum based grease.
4. Lubricate the distributor O-ring seal and tank O-ring seal.  
Use only non-aerosol silicone lubricant.
5. Load media and place the control valve on the tank.
6. All soldering **MUST** be done on any connections requiring soldering prior to connecting the main control valve.  
The main control valve will be damaged if it is connected at the time of soldering.
7. Apply Teflon tape to all threaded fittings.
8. On units with a bypass, place in **Bypass** position.
  - Turn on the main water supply.
  - Open a cold soft water tap nearby and let water run a few minutes or until the system is free of foreign material (usually solder) resulting from the installation. Close the water tap when water runs clean.
9. Make plumbing connections to valve.
10. Plug the valve into an approved power source.  
**NOTE: Make all electrical connections according to codes.**
11. Place the bypass In Service position. Cycle the valve to the Backwash position, and let the water flow slowly into the mineral tank until the air is purged from the unit.
12. Add water to the brine tank until the top of the air check is covered. Manually step the valve to the Brine Draw Position, and allow the valve to draw water from the brine tank until it stops.  
**NOTE: The air check will check at approximately the midpoint of the screened intake area.**
13. Manually step the valve to the Brine Refill Position, and allow the valve to return to In Service automatically.
14. With the valve In Service, check that there is at least 1" of water above the grid in the brine tank, if used.
15. Fill the brine tank with salt.
16. Allow the control to run automatically. Setup is now complete.

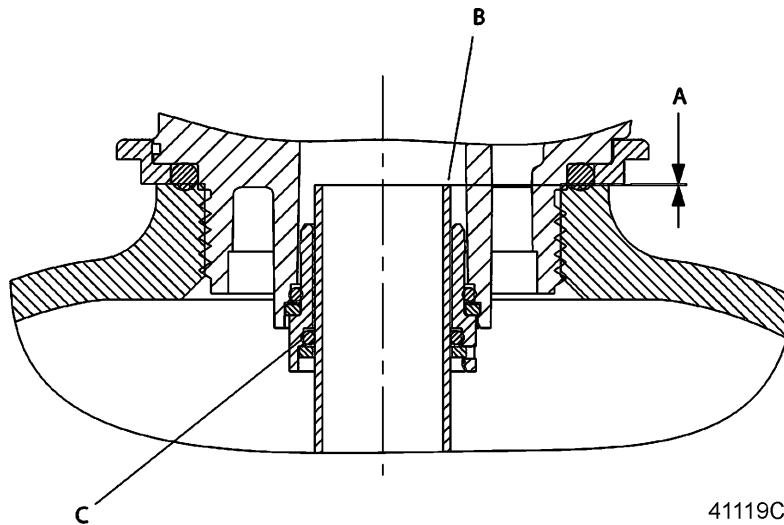

---

# 7000 Control Operation and Settings

---

## Display

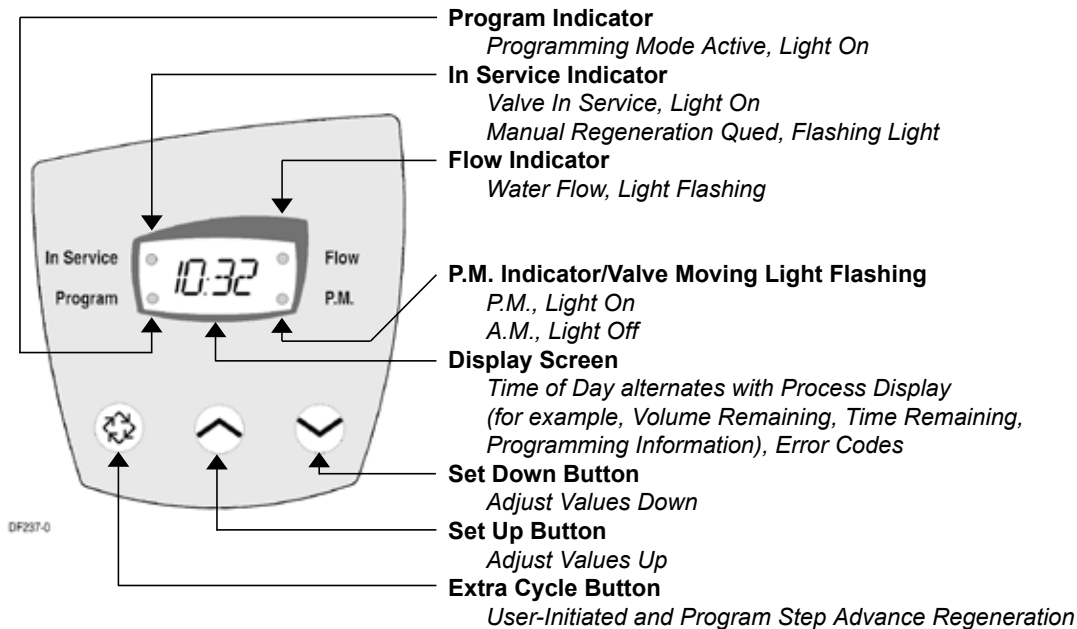

## Time Clock or Day of the Week Regeneration Valves

In normal operation the Time of Day Display may be viewed at all times. The control operates for a preset number of days between Regeneration cycles. When the number of days since the last Regeneration reaches the preset number of days, a Regeneration cycle initiates at the preset Regeneration Time.

Program the number of days between Regeneration cycles and the Regeneration time using the 7000 Control Start-Up Procedures.

## Flow Meter Equipped Valves – General

Flow meter equipped valves calculate the volume of water that the system can treat between Regeneration cycles based on the system capacity which is preset by the system manufacturer in a Master Programming Mode and the feed water hardness which is programmed in the Start-Up procedure safety factor (Master Mode only).

The remaining system capacity displays in gallons or liters. The display has a range of 0 to 9999 (gallons or liters). If the remaining capacity exceeds 9999 liters when in the Metric Mode, then the display changes to millions of liters and a letter t is displayed as the first digit. The display then has a range of t1.0 (1,000,000) to t1.9 (1,900,000).

## Flow Meter Equipped Valves – Immediate Regeneration Mode

The Time Of Day display alternates with the Volume Remaining display in gallons or liters. The Meter dot flashes in direct relation to the water flow rate through the unit. As treated water is used, the Volume Remaining display counts down from a maximum value to zero and initiates a Regeneration cycle immediately.

---

# 7000 Control Operation and Settings

---

## Flow Meter Equipped Valves – Delayed Regeneration Mode

In Normal operation the Time Of Day display alternates with the Volume Remaining display. The flow dot flashes in direct relation to the water flow rate through the unit. As treated water is used, the Volume Remaining display counts down from a maximum value to zero. If the reserve is reached, a Regeneration queues. The display shows all dashes if the entire volume is depleted before the scheduled Regeneration time. At the preset Regeneration Time, a Regeneration cycle initiates.

## Control Operation During Regeneration

In Regeneration the display shows the Regeneration status two ways:

- When the valve advances to the next position, the display flashes the number of that next position followed by three dashes.
- Once the valve reaches a position the display shows that position and number of minutes left in that Regeneration step.

**NOTE: If the step time exceeds 100, the leading digit flashes.**

- Once all Regeneration steps are complete, the valve returns to In Service and resumes normal operation.

NOTE: Pressing the Extra Cycle Button during a Regeneration cycle immediately advances the valve to the next cycle step position and resumes normal step timing.

## Control Operation During Programming

The control enters Program Mode with the valve In Service. While in Program Mode the control continues to operate normally, monitoring water usage and keeping all displays up to date. Control programming is stored in memory permanently. There is no need for battery backup power.

## Control Operation During a Power Failure

During a power failure all control displays and programming are stored for use upon power re-application. An inaccurate or flashing Time of Day display indicates that a power outage has occurred. During power failure the control:

- Is fully inoperative and any calls for Regeneration are delayed.
- Upon power re-application, resumes normal operation from the point that it was interrupted.
- Does not monitor the volume of water used during a power outage.
- In Delay Regeneration types, the reserve capacity is set to 1/3 the capacity.

## Manually Initiating a Regeneration

A Regeneration cycle may be initiated manually (referred to as an Extra Regeneration Cycle). There are two options when starting an Extra Regeneration Cycle:

- Press and release the Extra Cycle Button:
  - Flow Meter - Immediate Regeneration controls immediately go into a Regeneration cycle.
  - For Time Clock and Flow Meter - Delayed Regeneration controls, the In Service dot begins to flash immediately and a Regeneration occurs at the pre-programmed Regeneration time.



- Press and hold the Extra Cycle Button for five (5) seconds:
  - For Time Clock and Flow Meter - Delayed Regeneration controls, the control immediately begins the Regeneration cycle.

---

# 7000 Control Start-Up Procedures

---

## Set Time of Day

- Press the Set Up and Set Down buttons to set time of day.
  - Metric = 24 hour clock
  - US = 12 hour clock with PM indicator light



## Enter Control Programming Mode

- Press and hold both the Set Up and Set Down buttons for 5 seconds to enter Programming Mode. When the program mode is entered, the program dot turns on.



The 7000 controller performs 5 basic types of Regeneration systems. The type of system is selected by the system manufacturer and set in the Master Programming Mode. Basic systems are:

- **Time Clock**
  - The control operates for a preset number of days between Regeneration cycles. On the day that a Regeneration cycle is required the system regenerates at the preset Regeneration Time.
- **Meter Immediate**
  - The control regenerates immediately when the remaining capacity (volume of water that can be treated before a Regeneration is required) drops to 0.
- **Meter Delayed**
  - The control regenerates on the day that the remaining capacity drops to less than the reserve volume. Regeneration starts at the preset Regeneration Time.
- **Meter Delayed - Variable Brining**
  - The control regenerates on the day that the available volume of softened water drops to or below the reserve volume. Regeneration starts at the set Regeneration Time. With the variable brining option activated, the time setting for Cycle 1 is automatically calculated based on the volume of treated water at the time of regeneration. Cycle time 1 will not exceed the original time setting and is never less than 1 minute.
- **Day of the Week**
  - The control regenerates at the scheduled Regeneration Time on the day(s) of the week which are set by the user.

The Current Day of the Week display will alternate with the Time of Day when the control is In Service. The Day of the Week display will increment each day at 12:00 A.M. (Midnight).



---

# Programming a Meter Delayed Regenerated System

---

## 1. Feed water hardness (Display Code H).

**NOTE:** The feed water hardness setting only displays when the system is set to operate as a Meter Immediate or Meter Delayed system type.

- Press the Set Up or Set Down buttons to set the amount of feed water hardness in grains/gallon (U.S.) or degrees (metric). The system automatically calculates treated water capacity based on the feed water hardness and the system capacity preset in the Master Programming mode. "Calc" is displayed during calculations.

**Example: Range: 4 – 199 U.S. and metric**

- To program 9 grains / gallon (U.S.) or 9 degrees (metric) [ H -- 9]
- Press the Set Up and Set Down buttons to adjust this value.
- Press the Extra Cycle button once to advance to the next step.

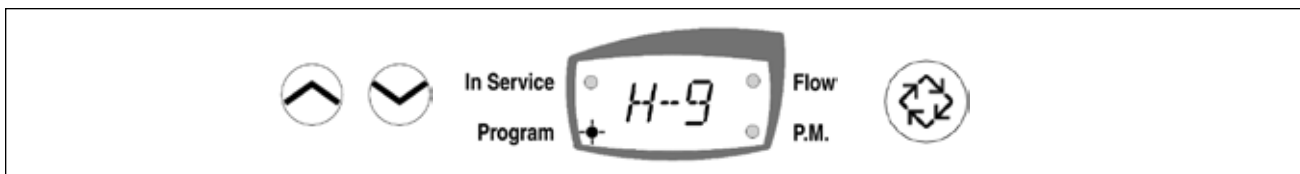

## 2. Regeneration Time (No display Code)

**NOTE:** The Regeneration Time setting does not display in Meter Immediate Regeneration Mode since the system regenerates immediately when the available capacity reaches 0.

Identify the Regeneration Time display by observing a non-flashing colon between two sets of numbers. Set the desired time of day for Regeneration to occur.

**Example: 2 o'clock A.M. regeneration time: [ 2:00 ] (P.M. Indicator Dot Off)**

- Press the Set Up and Set Down buttons to adjust this value.
- Press the Extra Cycle button to exit the programming mode or press and hold the Set Up and Set Down buttons simultaneously for five (5) seconds to enter the Extended Setup Programming Mode.



# Programming a Meter Delayed Regenerated System

## 3. EXTENDED Programming Mode

### Regeneration Cycle Step Programming (Display Code 1 to 6)

Use this feature to program the Regeneration Cycle step times. The Regeneration Cycle Step being programmed appears in the first digit of the display. Each display is used to set the duration time in minutes of that specific step in the regeneration cycle.

Example:

Cycle Step	dF	dFFF	FLtr
1	10 = Backwash	12 = Fill	10 = Backwash
2	60 = Brine Draw	60 = Brine Making	10 = Rapid Rinse
3	5 = 2nd Backwash	10 = Backwash	
4	10 = Rapid Rinse	60 = Brine Draw	
5	12 = Refill	5 = 2nd Backwash	
6		10 = Rapid Rinse	

- Use the Set Up and Set Down buttons to adjust this value.
- Press the Extra Cycle button to advance to the extended diagnostics.

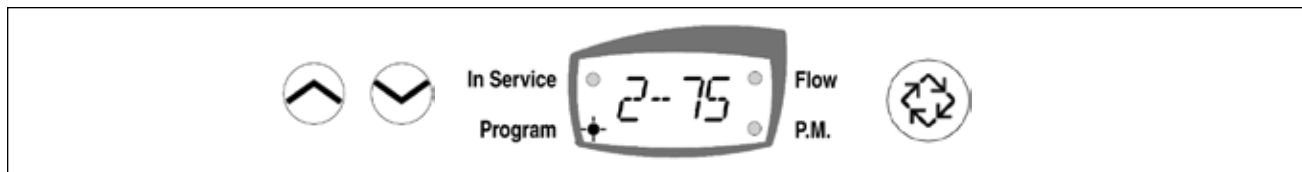

## 4. EXTENDED Diagnostics Mode (Viewable Only)

(Dy xx) Display Code xx = days since last Regeneration

- Press the Extra Cycle button once to advance to the next diagnostics.

(xxxx) No Display Code xxxx = volume used since the last Regeneration.

(yyyy) No display code yyyy = Reserve Volume.

- Press the Extra Cycle button once to Exit Extended Setup Programming Mode.

**Control Programming Complete**

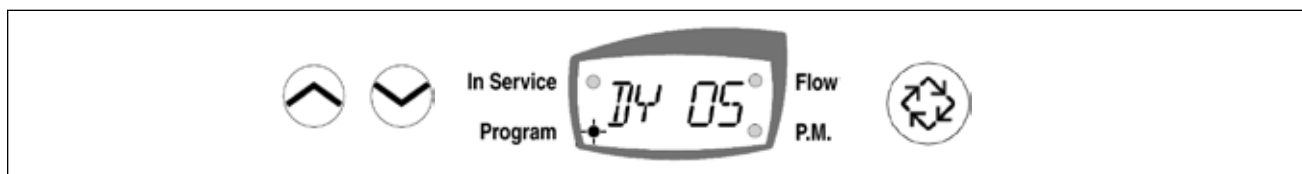

# Programming a Meter Immediate Regeneration System

## 1. Feed water hardness (Display Code H)

The feed water hardness setting displays only if the system is set to operate as a Meter Immediate or Meter Delayed system type.

- Press the Set Up and Set Down buttons to set the amount of feed water hardness (grains/gallon or degrees). The system automatically calculates treated water capacity based on the feed water hardness and the system capacity preset in the Master Programming mode.

**Example: Range: 4 – 199 US and Metric**

- To program 9 grains / gallon (US) or 9 degrees (Metric) [H – 9]
- Press the Set Up and Set Down buttons to adjust this value.
- Press the Extra Cycle button once to Exit Setup Programming Mode or press and hold the Set Up and Set Down buttons simultaneously for five (5) seconds to enter the Extended Setup Programming Mode.

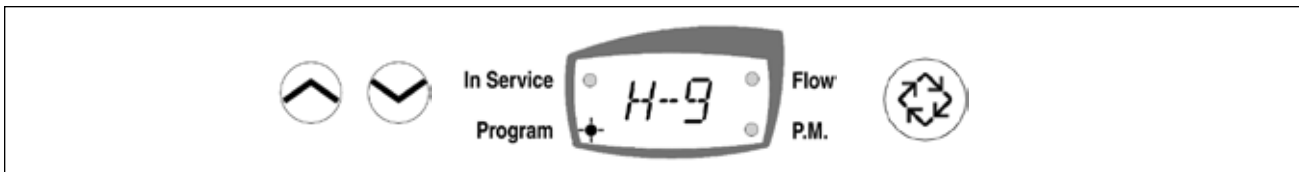

## 2. EXTENDED Programming Mode

### Regeneration Cycle Step Programming (Display Code 1 – 6)

This Program Step is used to program the Regeneration Cycle step times. The Regeneration Cycle Step being programmed is displayed in the first digit of the display. Each display is used to set the duration time in minutes of that specific step in the Regeneration cycle.

**Example:**

Cycle Step	dF	dFFF	FLtr
1	10 = Backwash	12 = Fill	10 = Backwash
2	60 = Brine Draw	60 = Brine Making	10 = Rapid Rinse
3	5 = 2nd Backwash	10 = Backwash	
4	10 = Rapid Rinse	60 = Brine Draw	
5	12 = Refill	5 = 2nd Backwash	
6		10 = Rapid Rinse	

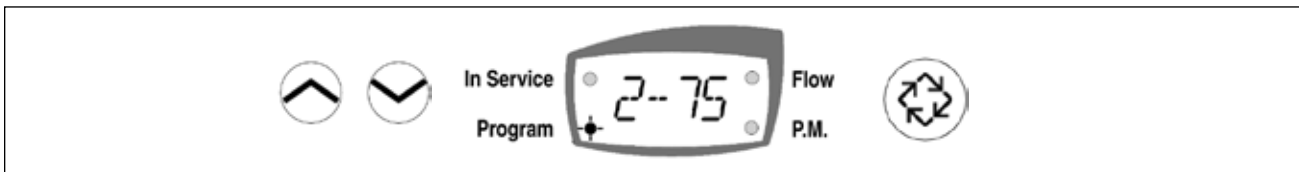

---

## Programming a Meter Immediate Regeneration System

---

### 3. Extended Diagnostics Mode (Viewable Only)

(Dy xx) Display Code xx = days since last Regeneration

— Press the Extra Cycle button once to advance to the next diagnostics.

(xxxx) No Display code xxxx = the volume used since the last Regeneration

— Press the Extra Cycle button once to Exit Extended Setup Programming Mode.

**Control Programming Complete**

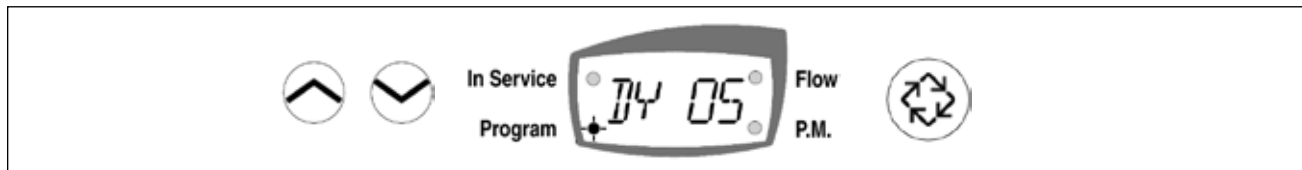

## Programming a Time Clock Regeneration System

### 1. Regeneration Time (No Display Code)

The Regeneration Time display can be identified by observing a non-flashing colon between two sets of numbers. Set the desired time of day that you want Regeneration to occur.

**Example: 2 o'clock A.M. regeneration time: [ 2:00 ] (P.M. Indicator Dot Off)**

— Use the Set Up and Set Down buttons to adjust this value.

— Press the Extra Cycle button to proceed to the next step.



### 2. Regeneration Day (Display code A)

Use this display to set the number of days between Regeneration cycles. This setting is identified by observing the letter "A" in the first digit. In the Time Clock regeneration mode, the system regenerates at the time set in Step 1 on the programmed number of days.

**Example: Regeneration every 7 days [A--7]**

— Use the Set Up and Set Down buttons to adjust this value.

— Press the Extra Cycle button once to Exit Setup Programming Mode or press and hold the Set Up and Set Down buttons simultaneously for five (5) seconds to enter the extended setup programming mode.

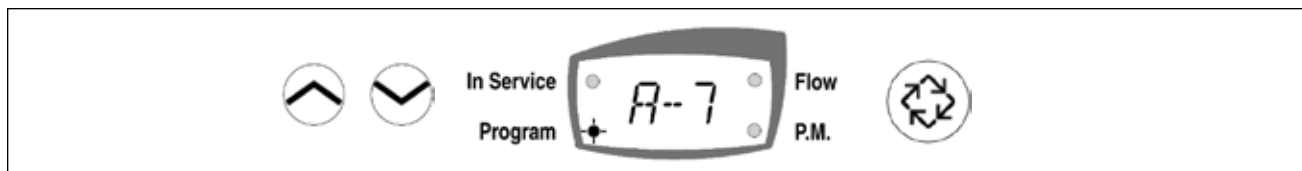

# Programming a Time Clock Regeneration System

## 3. Extended Programming Mode

### Regeneration Cycle Step Programming (Display Code 1 – 6)

This Program Step is used to program the Regeneration Cycle step times. The Regeneration Cycle Step being programmed is displayed in the first digit of the display. Each display is used to set the duration time in minutes of that specific step in the Regeneration cycle.

#### Example:

Cycle Step	dF	dFFF	FLtr
1	10 = Backwash	12 = Fill	10 = Backwash
2	60 = Brine Draw	60 = Brine Making	10 = Rapid Rinse
3	5 = 2nd Backwash	10 = Backwash	
4	10 = Rapid Rinse	60 = Brine Draw	
5	12 = Refill	5 = 2nd Backwash	
6	10 = Rapid Rinse		

- Use the Set Up and Set Down buttons to adjust this value.
- Press the Extra Cycle button once to proceed to the diagnostics.

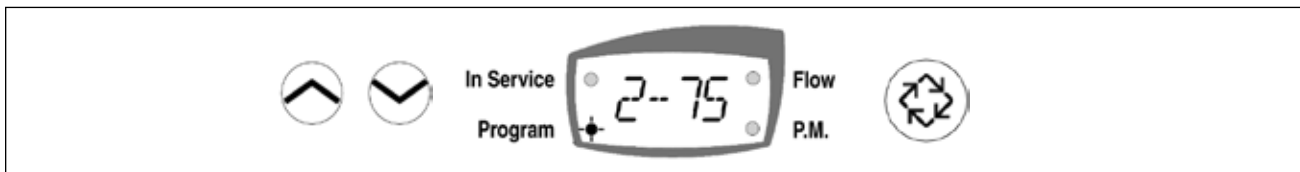

## 4. Extended Diagnostics Mode (Viewable Only)

(Dy xx) Display Code xx = days since last Regeneration.

- Press the **Extra Cycle** button once to advance to the next diagnostics.

(xxxx) No Display code xxxx = the volume used since the last Regeneration

- Press the Extra Cycle button once to Exit Extended Setup Programming Mode.

**Control Programming Complete**

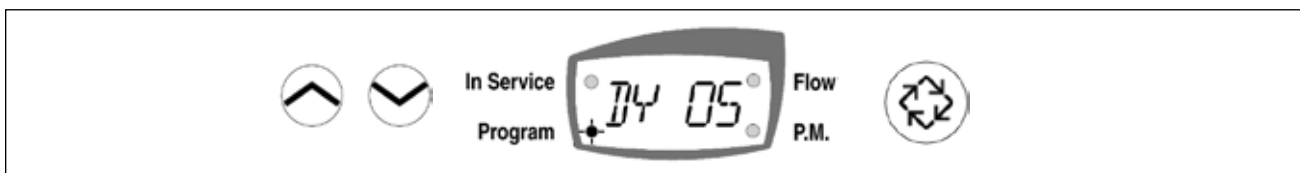

---

# Programming a Day of the Week Regenerated System

---

## 1. Regeneration Time (No Display Code)

**NOTE:** The Regeneration Time setting does not display in Meter Immediate Regeneration Mode since the system regenerates immediately when the available capacity reaches 0.

Identify the Regeneration Time display by observing a non-flashing colon between two sets of numbers.

Set the desired Time of Day for Regeneration to occur.

**Example: 2 o'clock A.M. Regeneration Time: [ 2:00 ] (P.M. Indicator Dot Off)**

- Press the Set Up and Set Down buttons to adjust this value.
- Press the Extra Cycle button to exit the Programming Mode or press and hold the Set Up and Set Down buttons simultaneously for 5 seconds to enter the Extended Setup Programming Mode.



## 2. Current Day of the Week

Use the display to enter the current day setting. Enter day 1 through day 7.

**Example: If Monday, setting is Day 1. If Tuesday, setting is day 2, etc.**

- Press the Set Up and Set Down buttons to adjust this value.
- Press the Extra Cycle button to advance and set the individual day(s) on which a regeneration will occur.

**NOTE:** The current day display is incremented each day at 12:00 AM (Midnight).

- Press the Extra Cycle button once to advance to the next step.

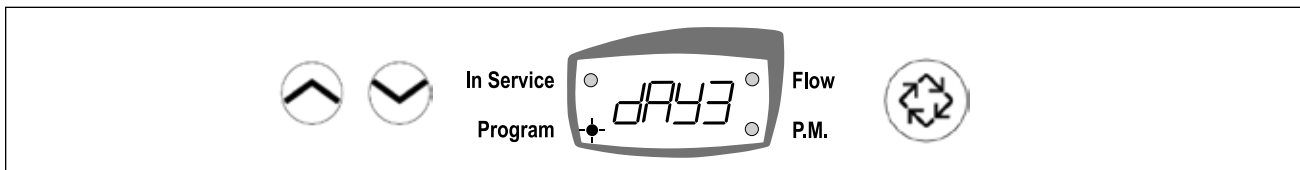

## 3. Individual Day of the Week Regeneration Setting

- Set to 1 or 0 using the Set Up and Set Down buttons (1 enables regeneration for that day; 0 disables regeneration for that day)
- Press the Extra Cycle button once to exit Setup Programming Mode or press and hold the Set Up and Set Down buttons for 5 seconds when viewing the regeneration time (Ex: 2:00 A.M.) to enter the Extended Programming Mode.

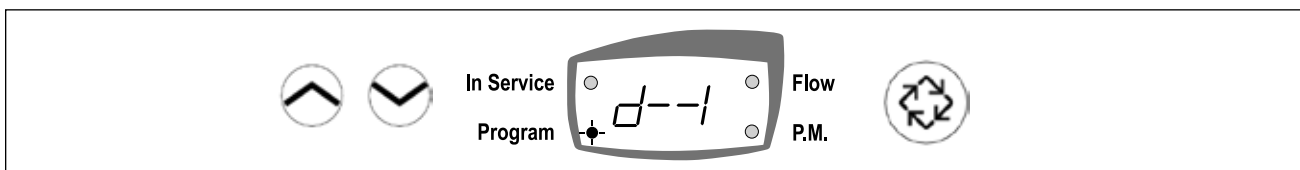

---

# Programming a Day of the Week Regenerated System

---

## 1. Extended Programming Mode

### Regeneration Cycle Step Programming (Display Code 1 – 6)

Use this feature to program the Regeneration Cycle step times. The Regeneration Cycle Step being programmed appears in the first digit of the display. Each display is used to set the duration time in minutes of that specific step in the regeneration cycle.

**Example:**

Cycle Step	dF	dFFF	FLtr
1	10 = Backwash	12 = Fill	10 = Backwash
2	60 = Brine Draw	60 = Brine Making	10 = Rapid Rinse
3	5 = 2nd Backwash	10 = Backwash	
4	10 = Rapid Rinse	60 = Brine Draw	
5	12 = Refill	5 = 2nd Backwash	
6		10 = Rapid Rinse	

- Use the Set Up and Set Down buttons to adjust this value.
- Press the Extra Cycle button once to proceed to the next step.
- Set to 1 or 0 using the Set Up and Set Down buttons (1 enables a regeneration for that day; 0 disables a regeneration for that day).
- Press the Extra Cycle button once to exit Setup Programming mode.

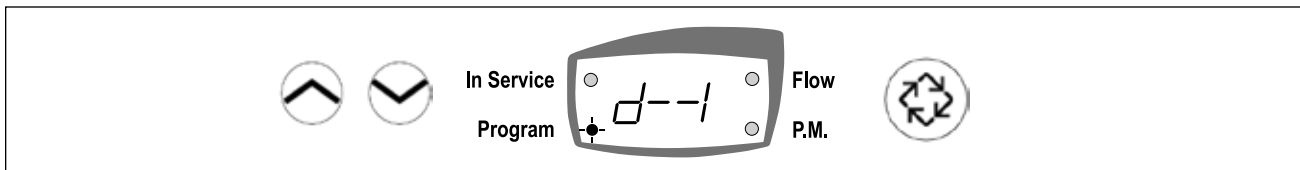
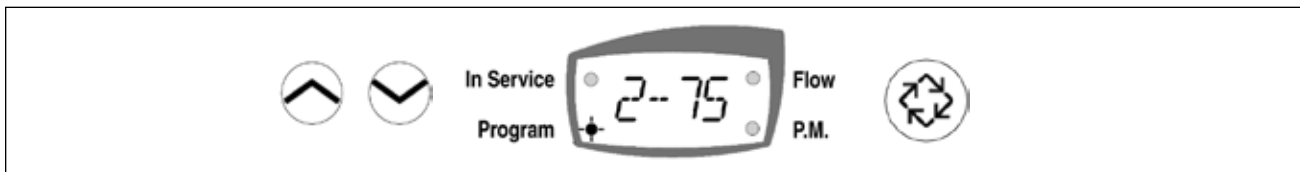

# Water Conditioner Flow Diagrams

## In Service Position

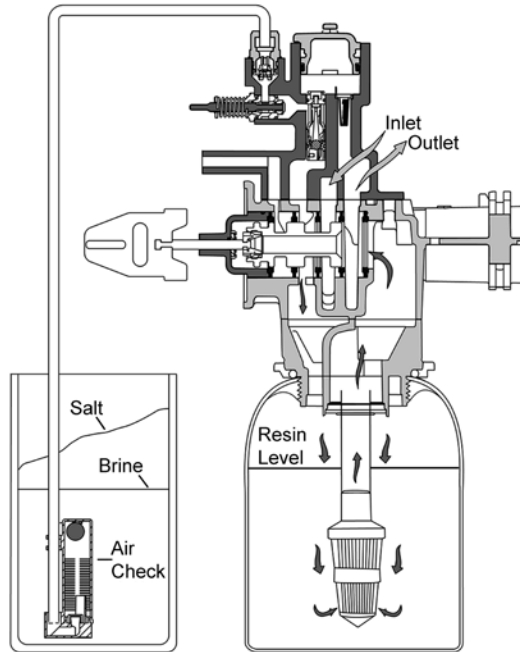
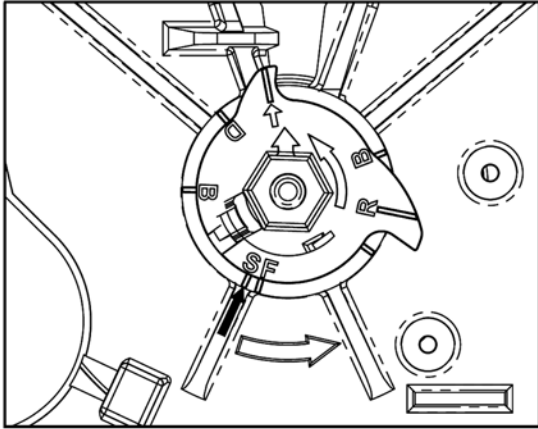

## Backwash Position

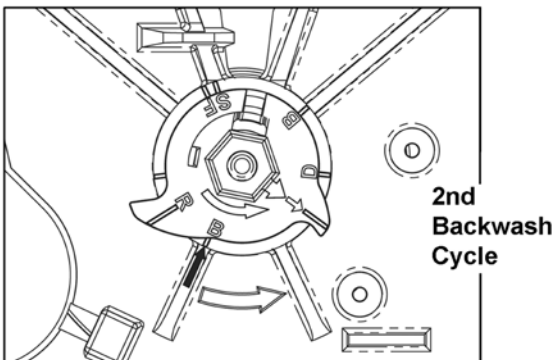
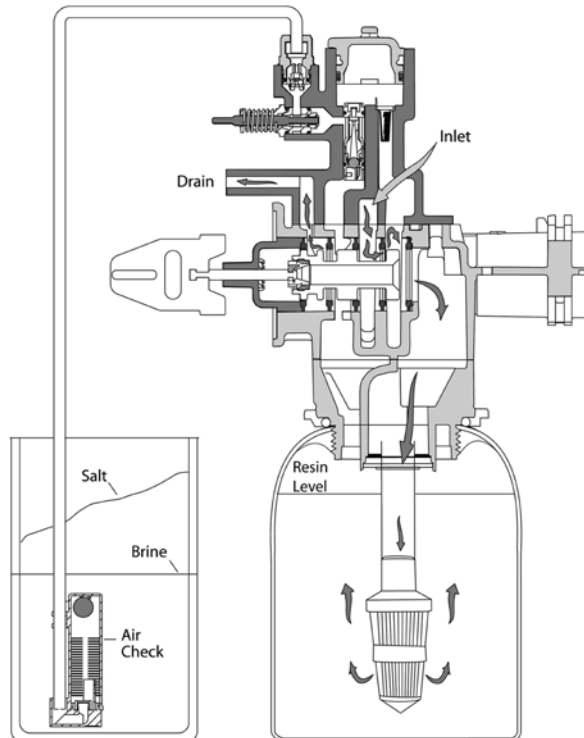
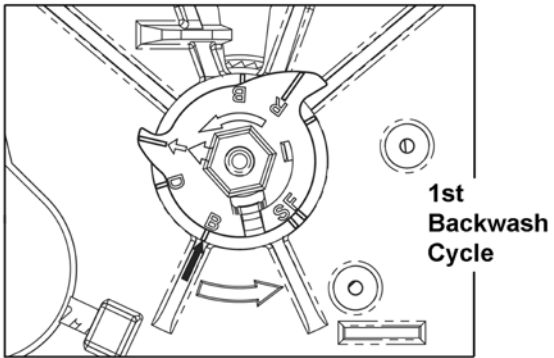



---

# Water Conditioner Flow Diagrams

---

## Brine Position

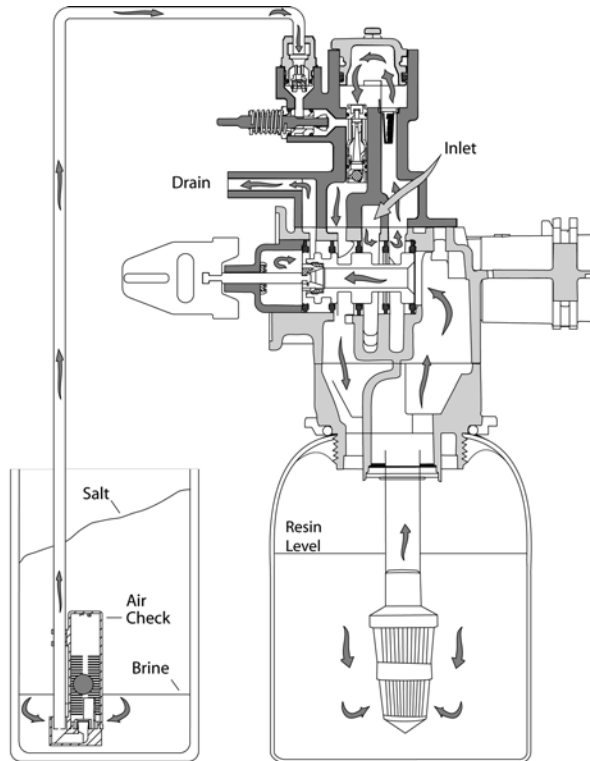
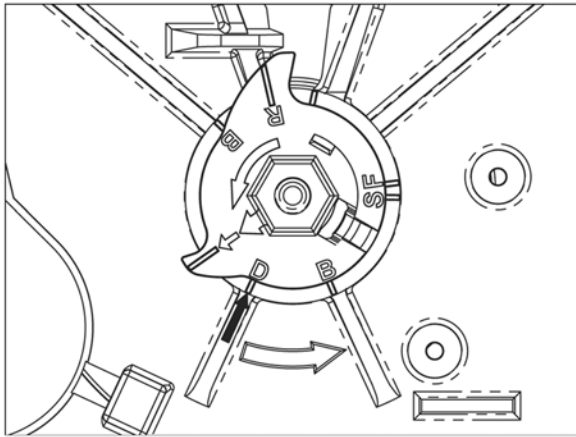

## Slow Rinse Position

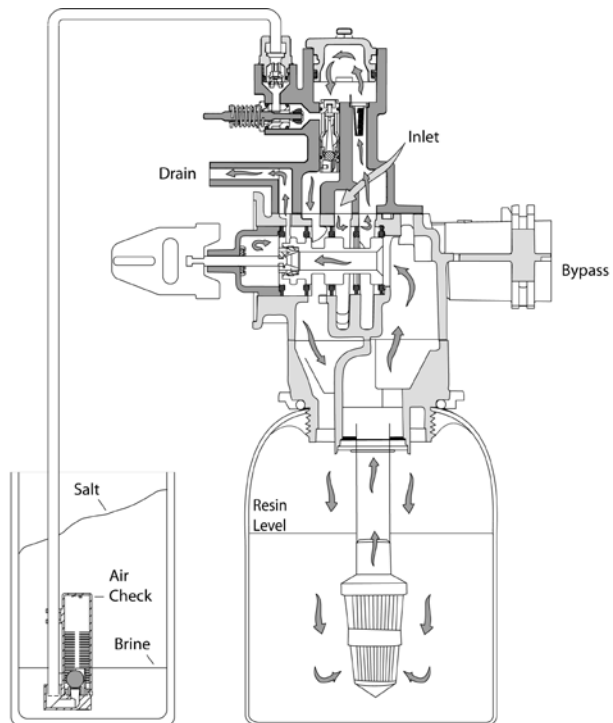
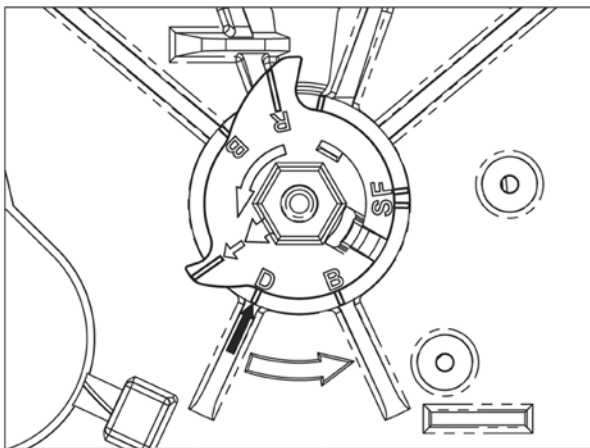

---

# Water Conditioner Flow Diagrams

---

## Rapid Rinse Position

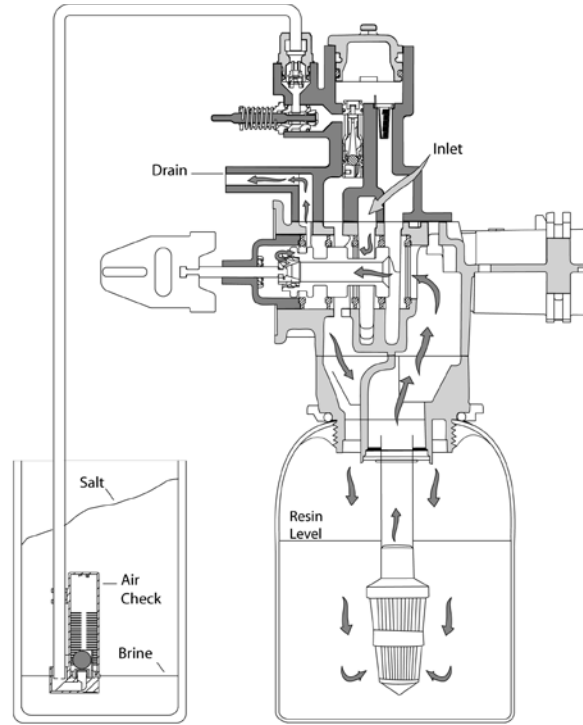
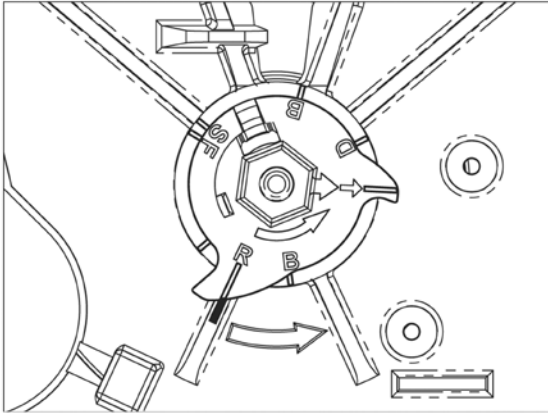

## Brine Tank Refill Position

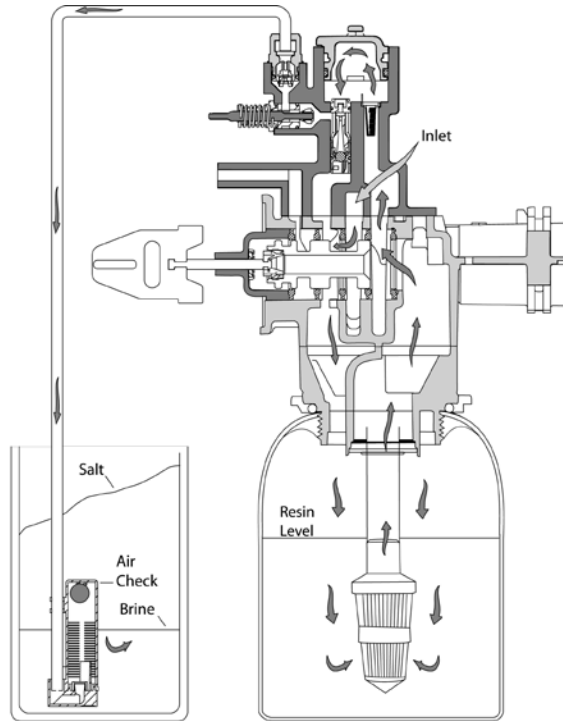
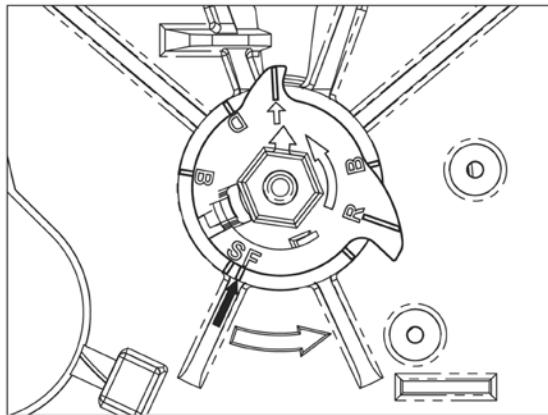



# Power Head Assembly

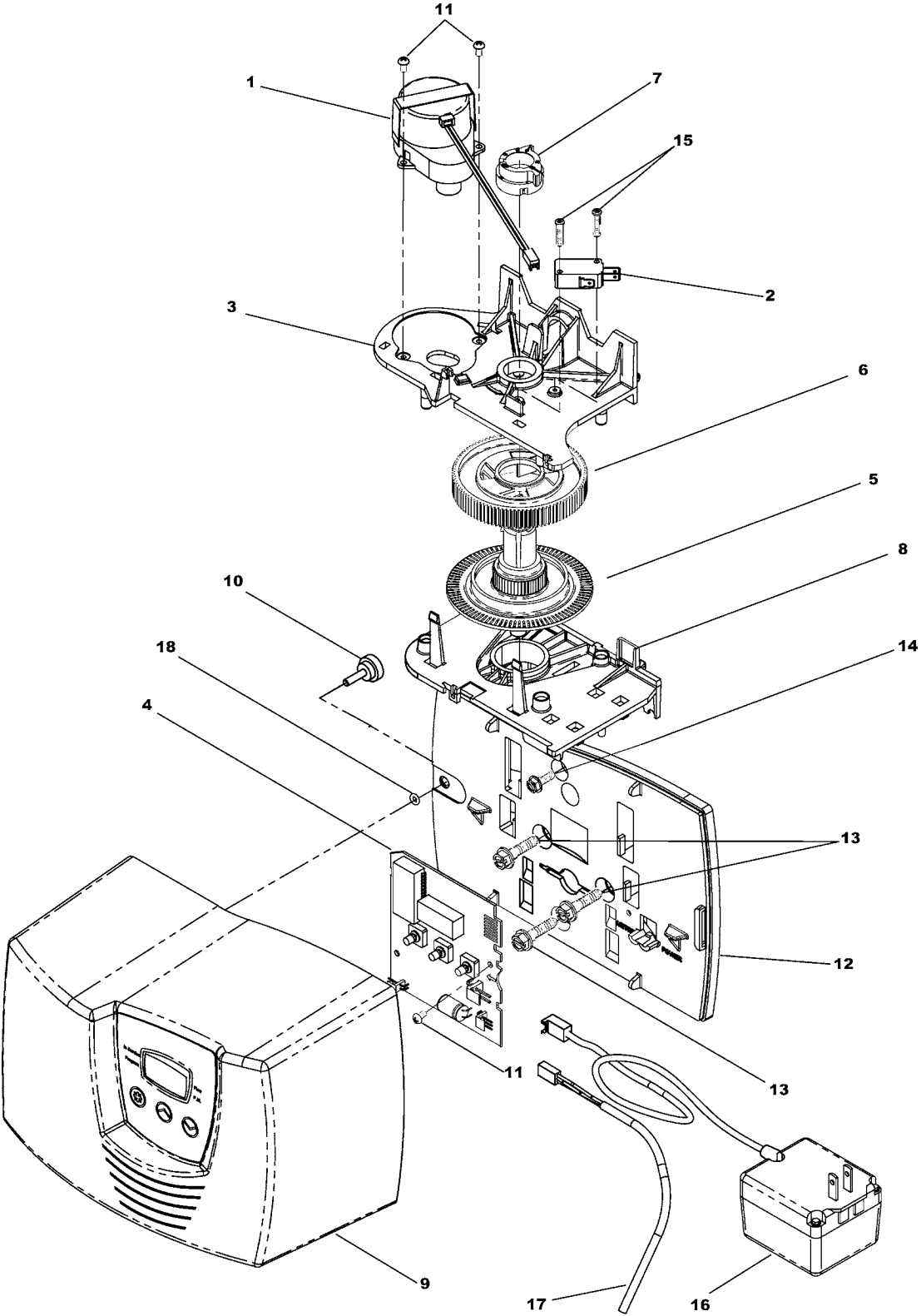

---

## Power Head Assembly Parts List

---

Item No.	Quantity	Part No.	Description
1	1	40968	Motor, 24V 50/60 Hz
2	1	10218	Switch, Micro
3	1	40978	Plate, Upper Support
4	1	61460	Circuit Board Kit, 7000
5	1	40702	Shaft, Encoder, 7000
6	1	40703	Gear, Main
7	1	40704	Cam, Brine, Downflow
		40977	Cam, Aux Switch, Filter
8	1	40979	Plate, Lower Support
9	1	61430	Cover Assy, 7000, Gray
		61431	Cover Assembly, 7000, Black
10	1	19367	Screw, Designer Cover, Thumb
11	3	13602	Screw, Phil Rd Hd, 6-32 x 5/16
12	1	40980	Backplate, 7000
13	3	40967	Screw, Hex Washer, Slotted
14	1	15727	Screw, Hex Wsh Hd, 10-24 x 1/2
15	2	11805	Screw, Rd Hd, 4-40 x 5/8 Type 1
16	1	40981	Transformer, US 24V, 9.6VA, 7000
		41086	Transformer Assy, 230/24V
17	1	19791-01	Meter Cable Assy, Turbine/SE
18	1	41122	O-ring, -007
Not Shown		41200	Label, Blank Configuration

# Valve Assembly

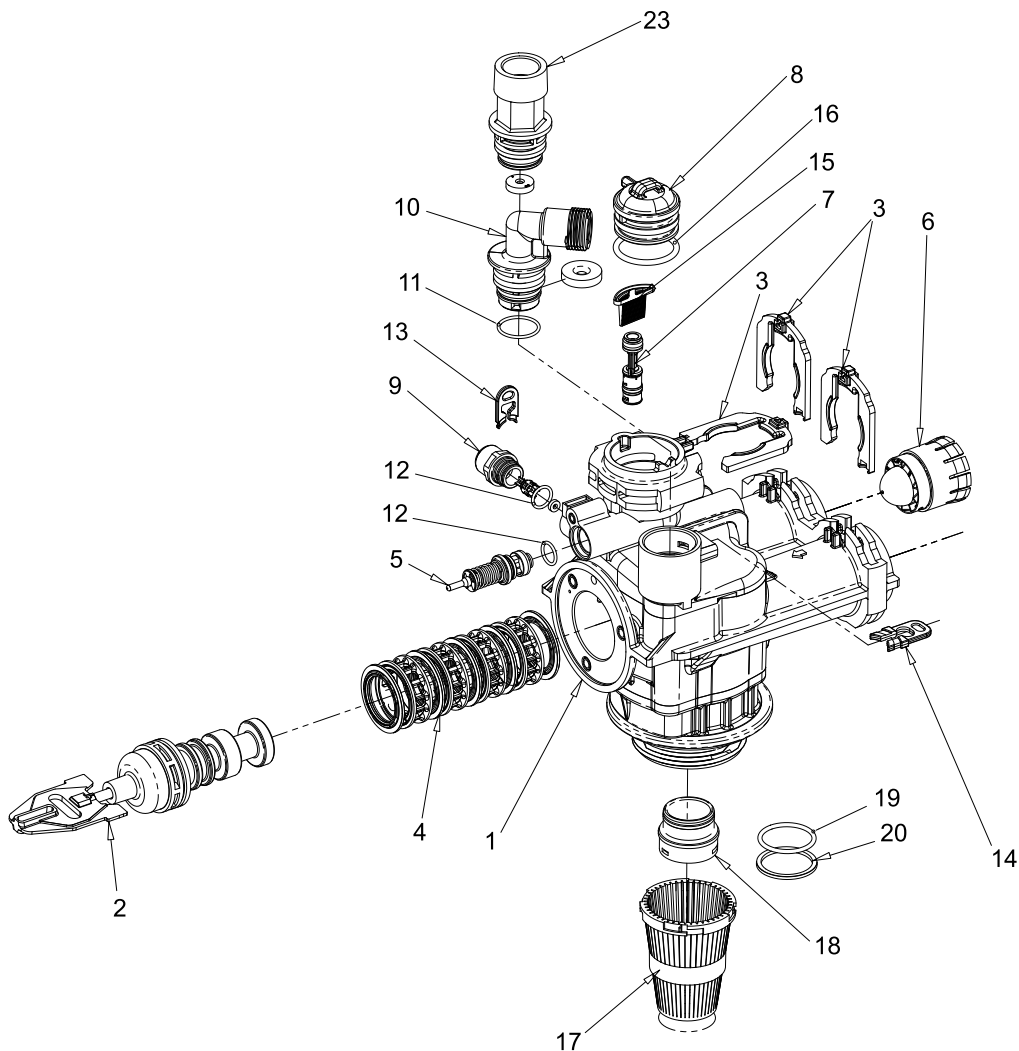

Item No.	Quantity	Part No.	Description
1	1	61050	Valve Body Assy, 7000, 32mm Dist
2	1	61542-10	Piston Assy, 7000, Softener, D/F 35GPM
		61453-10	Piston Assy, 7000, Softener, D/F 28GPM
		61452-20	Piston Assy, 7000, Filter 35GPM
3	3	40576	Clip, H, Plastic, 7000
4	1	61438	Seal & Spacer Kit, 7000, D/F
5	1	60016-01	Brine Valve Assy, 7000, 560CD
6	1	40577	Turbine Meter Assy, 7000
7	1	61XXX	Injector Assy, 7000

Part Number	Injector Number
61454-000	#000
61454-00	#00
61454-0	#0
61454-1	#1

# Valve Assembly Parts List

Item No.	No. Req'd	Part Number	Description
8.....	1 .....	40556.....	Cap, Injector
9.....	1 .....	61XXX.....	BLFC Assemblies

Part No.	Injector No.
61454-2.....	#2
61454-3.....	#3
61454-4.....	#4
61454-5.....	#5

10.....	1 .....	61XXX.....	DLFC Assemblies
---------	---------	------------	-----------------

Part No.	BLFC Size	GPM
61450-00.....	3/8" .....	Blank
61450-12.....	3/8" .....	0.125
61450-25.....	3/8" .....	0.25
61450-50.....	3/8" .....	0.50
61450-100.....	3/8" .....	1.0
61451-00.....	1/2" .....	Blank
61451-12.....	1/2" .....	0.125
61451-25.....	1/2" .....	0.25
61451-50.....	1/2" .....	0.50
61451-100.....	1/2" .....	1.0

11.....	1 .....	13303-01.....	O-ring, -021, 560CD
12.....	2 .....	13302-01.....	O-ring, -014, 560CD
13.....	1 .....	40946.....	Clip, Brine Retaining
14.....	1 .....	40945.....	Clip, Drain Retaining
15.....	1 .....	40950.....	Screen, Injector, 7000
16.....	1 .....	40951.....	O-ring, -220
17.....	1 .....	18280.....	Collector, Top, 1" x .011, Gray
18.....	1 .....	61419.....	Kit, 1.05" Distributor, Adapter
19.....	1 .....	19054.....	O-ring, -124
20.....	1 .....	18303-01.....	O-ring, -336, 560CD
23.....	1 .....	61XXX.....	DLFC Kits

Part No.	DLFC Size	GPM
61455-00.....	3/4" .....	Blank
61455-17.....	3/4" .....	1.7
61455-20.....	3/4" .....	2.0
61455-24.....	3/4" .....	2.4
61455-30.....	3/4" .....	3.0
61455-35.....	3/4" .....	3.5
61455-40.....	3/4" .....	4.0
61455-45.....	3/4" .....	4.5
61455-50.....	3/4" .....	5.0
61455-60.....	3/4" .....	6.0
61455-70.....	3/4" .....	7.0

Part Number	DLFC Size	GPM
61456-00 .....	1" .....	Blank
61456-8.0.....	1" .....	8.0
61456-9.0.....	1" .....	9.0
61456-10 .....	1" .....	10.0
61456-12 .....	1" .....	12.0
61456-15 .....	1" .....	15.0
61456-20 .....	1" .....	20.0
61456-25 .....	1" .....	25.0
61456-30 .....	1" .....	0.0

**Not Shown**

40677 .....	Tube, Distributor, 32MM
40924 .....	Distributor, 32MM
40697-02.....	Collector, 32MM Bayonet
12763-10.....	Stuffer Tool Assy, 7000

**Filter Valves**

40947-01.....	Plug, Brine Valve, w/O-ring
40990-01.....	Plug, Injector, w/O-ring

# Bypass Assembly

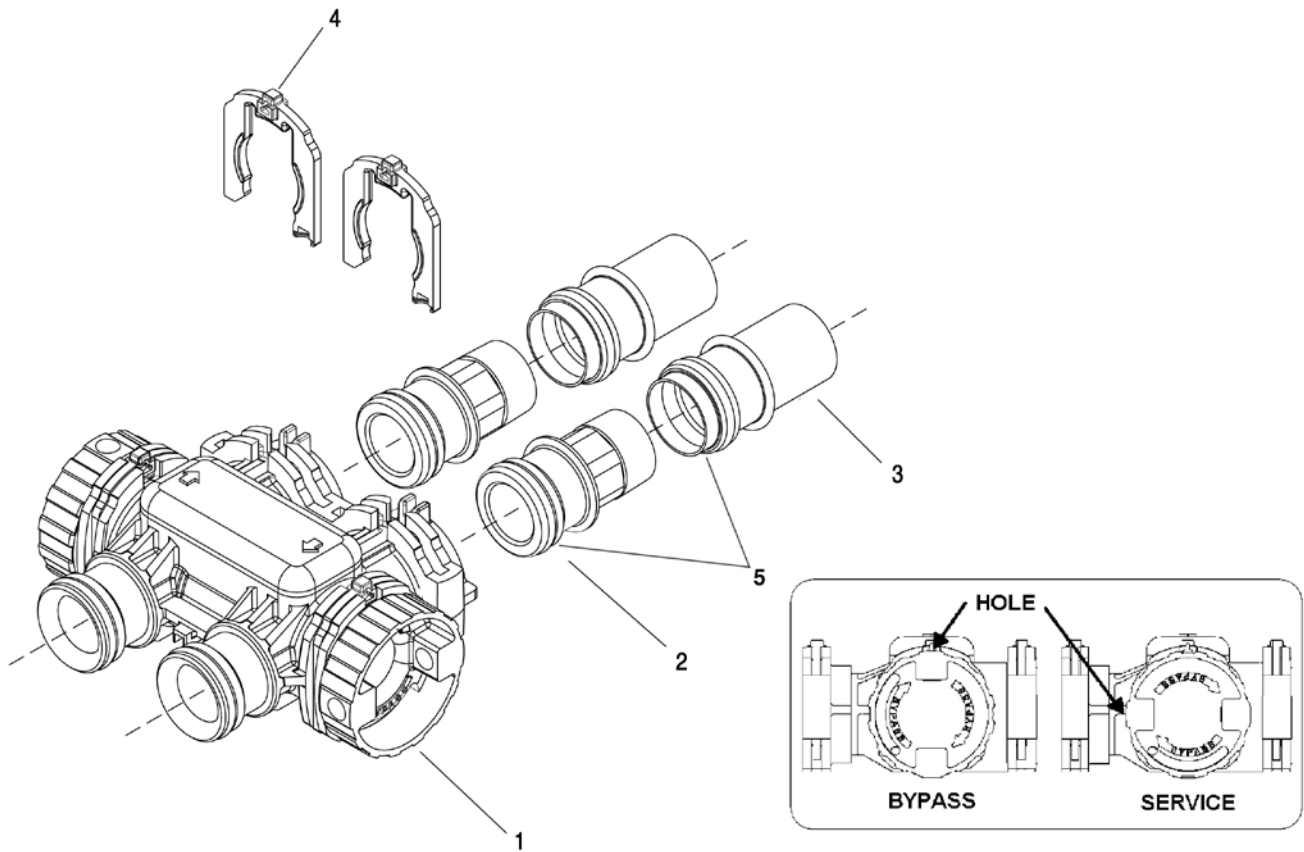

**IMPORTANT**

To bypass the valve, turn bypass knob on both sides of the valve to bypass position.

When returning to service, put the inlet into service before the outlet.

Item No.	Quantity	Part No.	Description
1	1	40569	Bypass Assembly, 7000, Less Clip
2	2	40563-01	Connector Assy, 1" NPT, w/O-ring
		40563-11	Connector Assy, 1" BSP, w/O-ring
		40565-01	Connector Assy, 1 1/4" NPT w/O-ring
		40565-11	Connector Assy, 1 1/4" BSP w/O-ring
3	2	41242-01	Connector Assy, 1" & 1/4" Sweat, w/O-ring
		41243-01	Connector Assy, 1 1/4" & 1 1/2" Sweat, w/O-ring
4	2	40576	Clip, H, Plastic, 7000
5	1	40951	O-ring, -220
Not Shown	1	61462	By-Pass Service Kit, 7000 (Includes all internal parts for 7000 bypass assembly - bypass body not included)



# 2310 Safety Brine Valve

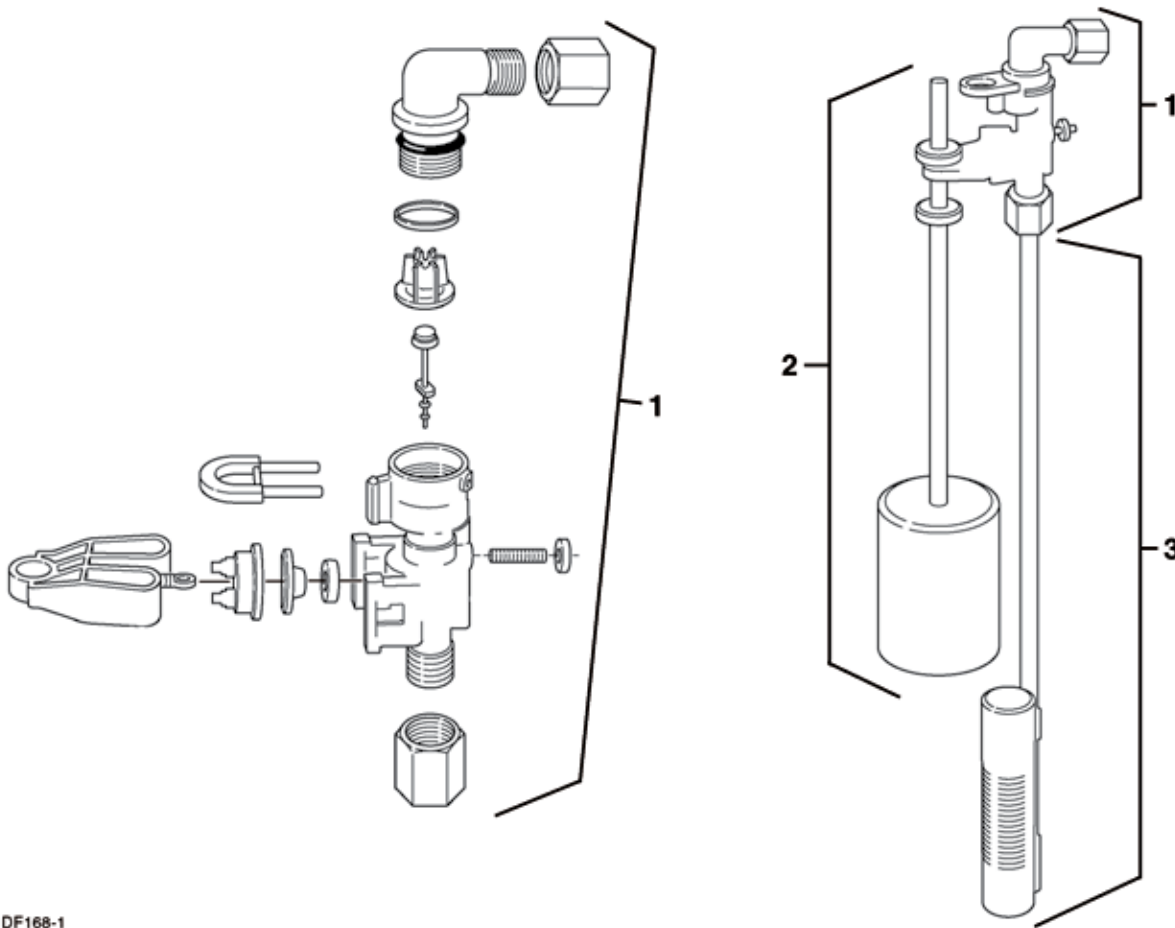

DF168-1

Item No.	Quantity	Part No.	Description
1	1	60014	Safety Brine Valve Assy, 2310
2	1	60068	Float Assy, 2310, w/30" Rod
		60026-30	Float Assy, 400A/2350, 30" Red/Wht
3	1	60002	Air Check, #500

# Troubleshooting

## Error Codes

**Note:** Error codes appear on the In Service display.

Error Code	Probable Cause	Recover and Resetting
[Err 0]	Drive motor is stalled	Unplug the unit from the power source
[Err 1]	Drive motor is running continuously	When power is restored to the unit, the Err _ display code clears. If the condition causing the error has not been resolved the Err _ code reappears in the four digit display. Do not attempt to troubleshoot this problem any further.
[Err 2]	<p>There have been more than 99 days since the last Regeneration. If the Day of the Week mode of regeneration is selected and days since last regeneration exceeds 7 days.</p> <p><b>[ 7 - - 5 ]:</b> There have been more than 7 days since the last regeneration. All individual settings (d1, d2, d3, d4, d5, d6, d7) are set to 0.</p>	<p>Regeneration must occur for the unit to recover, the display to clear and the valve to function normally.</p> <p><b>[ 7 - - 5 ]:</b> To recover from [Err2], the user must initiate a regeneration or set at least one individual day to 1.</p>



**WARNING**  
 The controller **MUST** be depressurized before removing any quick connection clips for servicing. The connector should be pushed toward the control while removing clips.

Problem	Cause	Correction
1. Softener fails to regenerate.	<p>A. Electrical service to unit has been interrupted.</p> <p>B. Timer is defective.</p>	<p>A. Assure permanent electrical service (check fuse, plug, pull chain or switch).</p> <p>B. Replace timer.</p>
2. Hard water.	<p>A. Bypass valve is open.</p> <p>B. No salt in brine tank.</p> <p>C. Injector screen plugged.</p> <p>D. Insufficient water flowing into brine tank.</p> <p>E. Hot water tank hardness.</p> <p>F. Leak at distributor tube.</p> <p>G. Internal valve leak.</p>	<p>A. Close bypass valve.</p> <p>B. Add salt to brine tank and maintain salt level above water level.</p> <p>C. Clean injector screen.</p> <p>D. Check brine tank fill time and clean brine line flow control if plugged.</p> <p>E. Repeated Flushing of the hot water tank is required.</p> <p>F. Make sure distributor tube is not cracked. Check O-ring and tube pilot.</p> <p>G. Replace seals and spacers and/or piston.</p>

## Troubleshooting

<b>Problem</b>	<b>Cause</b>	<b>Correction</b>
3. Unit uses too much salt.	A. Improper salt setting. B. Excessive water in brine tank.	A. Check salt usage and salt setting. B. See problem No. 7.
4. Loss of water pressure.	A. Iron buildup in line to water conditioner. B. Iron buildup in water conditioner.  C. Inlet of control plugged due to foreign material broken loose from pipe by recent work done on plumbing system.	A. Clean line to water conditioner. B. Clean control and add mineral cleaner to mineral bed. Increase frequency of regeneration and/or backwash time. C. Remove pistons and clean control.
5. Loss of mineral through drain line.	A. Air in water system.  B. Drain line flow control too large.	A. Assure that well system has proper air eliminator control. Check for dry well condition. B. Check to ensure drain line flow control is sized properly for your mineral tank.
6. Iron in treated water.	A. Fouled mineral bed.	A. Check backwash, brine draw and brine tank fill. Increase frequency of regeneration.
7. Excessive water in brine tank.	A. Plugged drain line flow control. B. Plugged injector system. C. Timer not cycling. D. Foreign material in brine valve. E. Foreign material in brine line flow control. F. Power loss during brine fill.	A. Check flow control.  B. Clean injector and screen. C. Replace timer. D. Replace brine valve seat and clean valve. E. Clean brine line flow control.  F. Check power source.

---

## Removing Gear Box Assembly

---

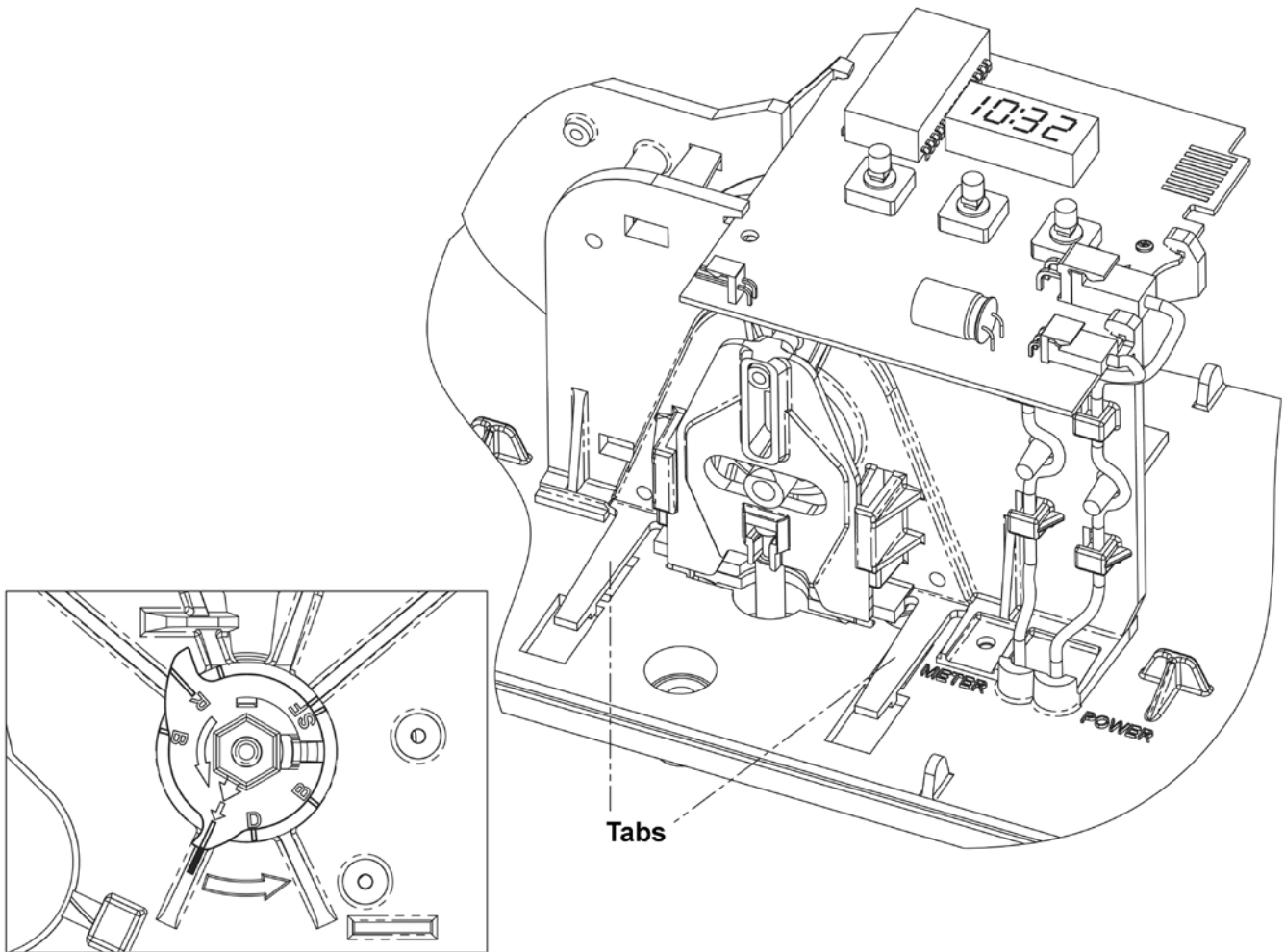

1. Unplug the power source.
2. With 3/8" nut driver, turn the cycle cam counter-clockwise to the position shown in illustration above.
3. Slightly pull the two tabs outward and push the gearbox slightly upward to remove.
4. When returning valve to service after powerhead disassembly, manually step valve through regeneration using the extra cycle button until valve is in service.

---

## Inserting Circuit Board

---

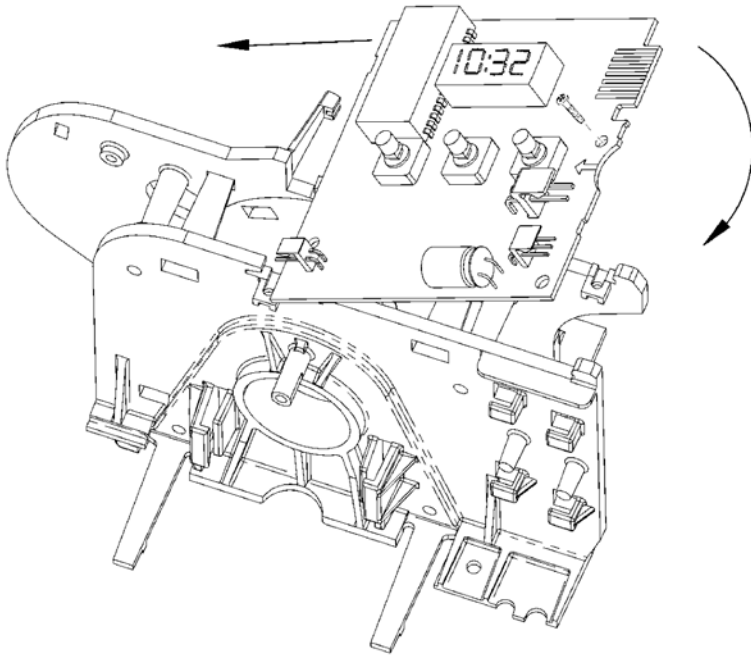

1. To insert the circuit board, align the notches on the left side of the board with the flexible finger on the power head. Apply pressure to the left while rotating the board back.

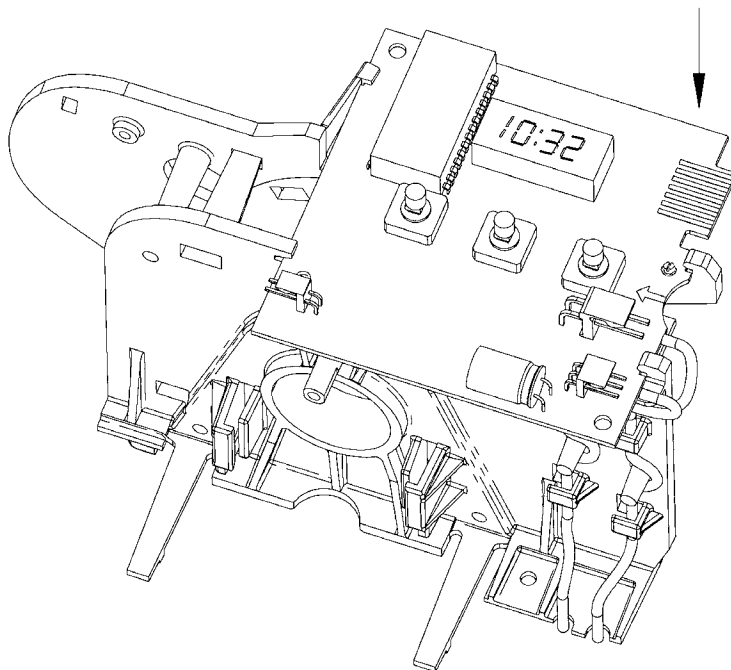

2. When all the way down, snap the circuit board into place under the notches on the right.

---

## Connecting the Circuit Board

---

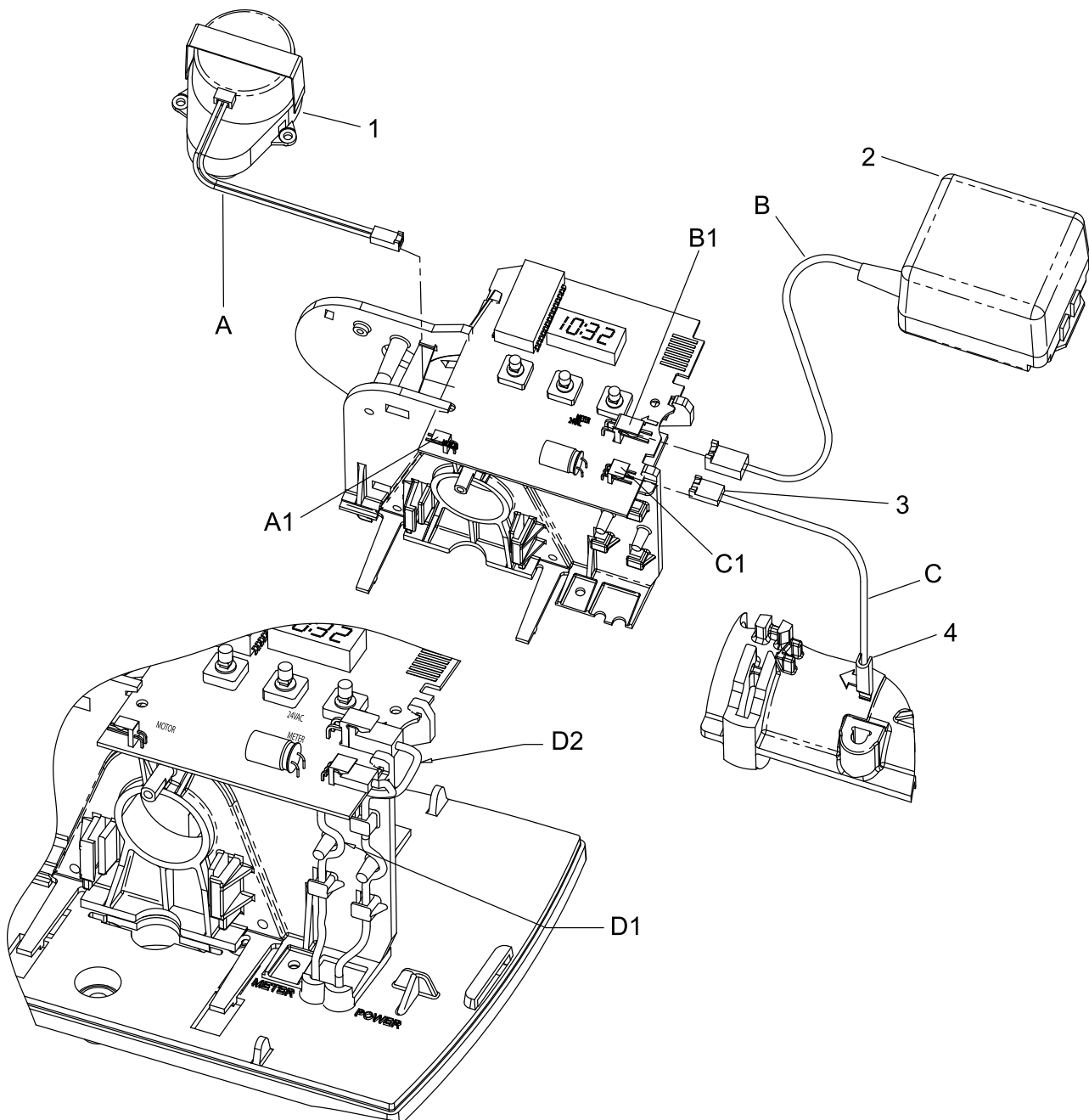

After the circuit board is installed:

1. Connect the motor wires (A) to the motor connector (A1) on board.
2. Connect the transformer cable (B) to the transformer connector (B1) on board.
3. Connect the meter cable (C) to the meter cable connector (C1) on board.
4. Connect the meter cable sensor end to the opening on the valve body.
5. Thread meter cable (D1) and power wire (D2) along path shown in above illustration.

# Dimensions

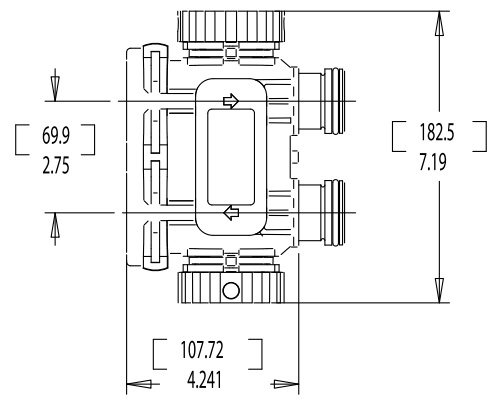
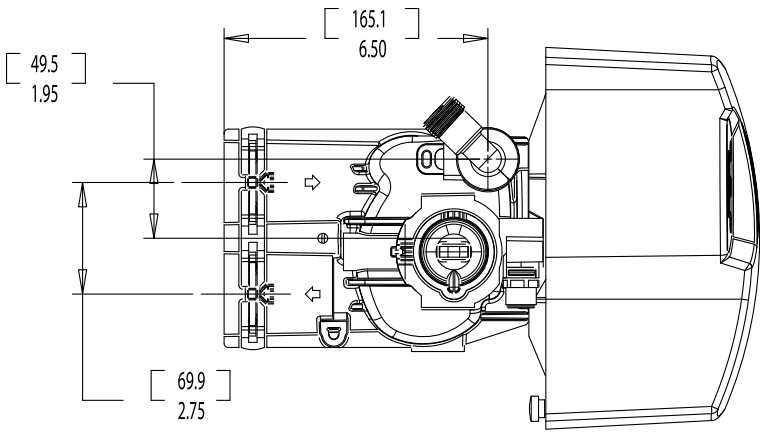

BYPASS

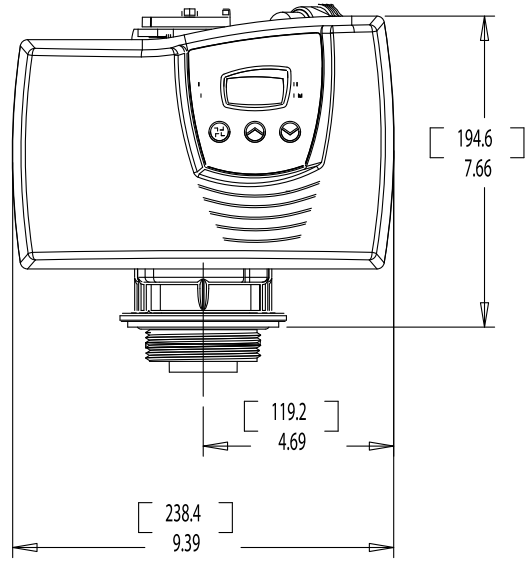
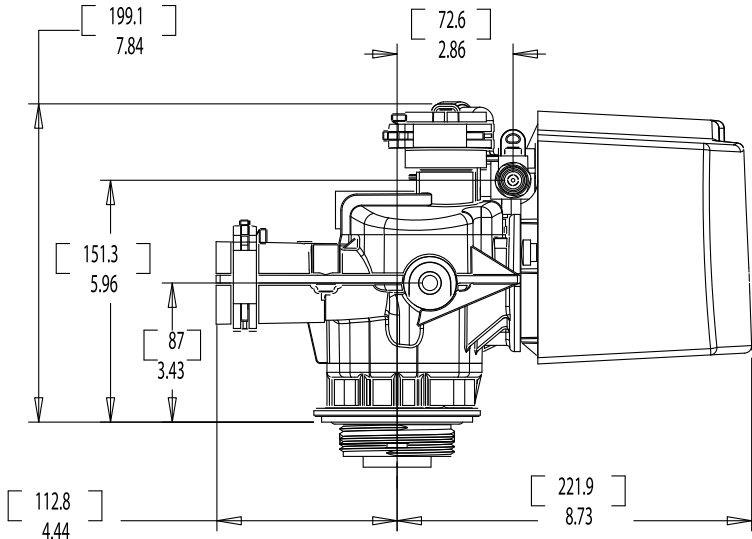

# Meter Flow Data

## 7000 Valve

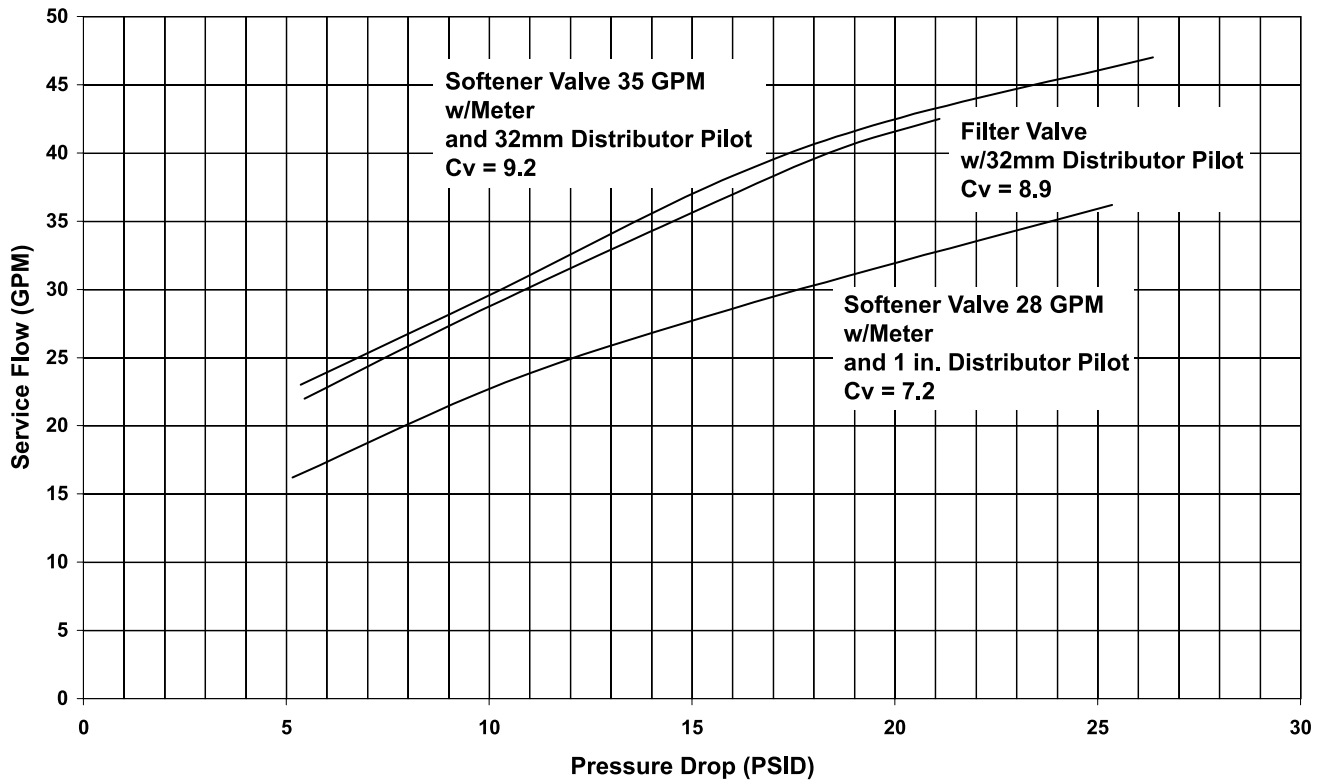



# Injector Flow Data

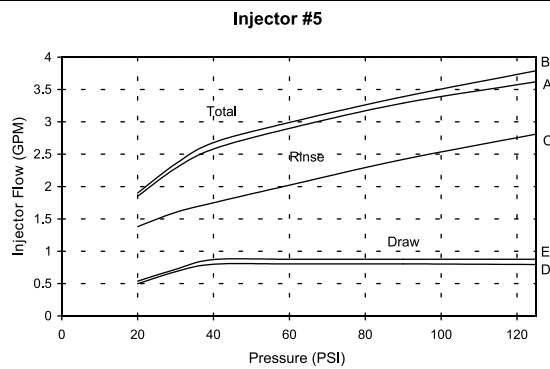
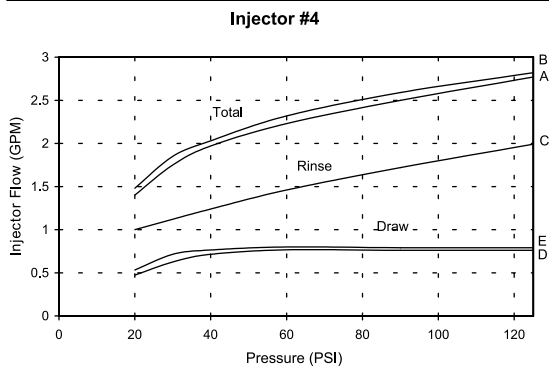
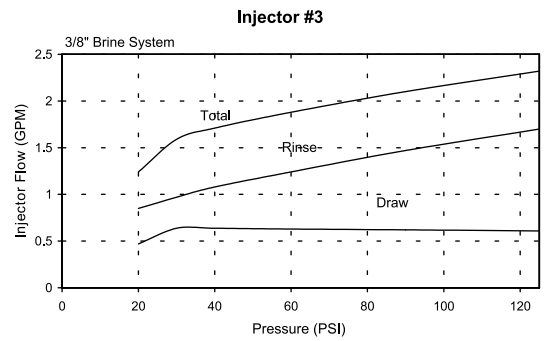
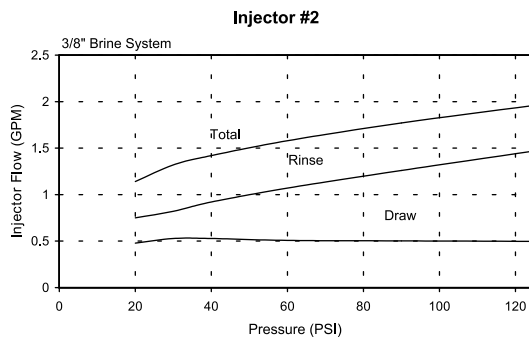
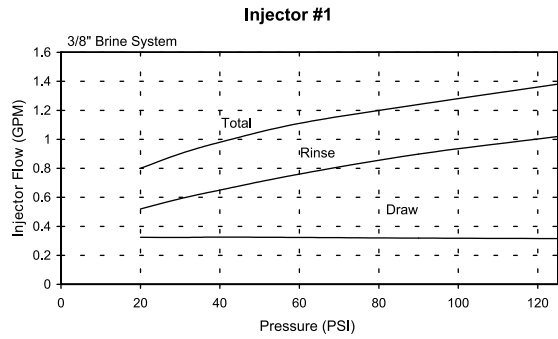
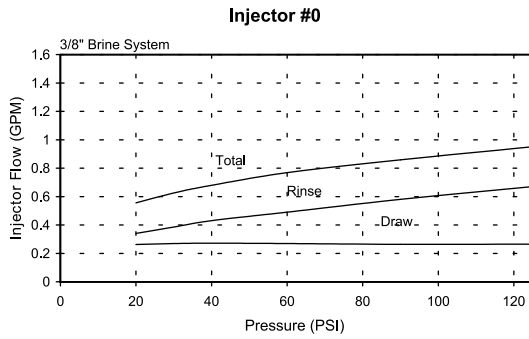
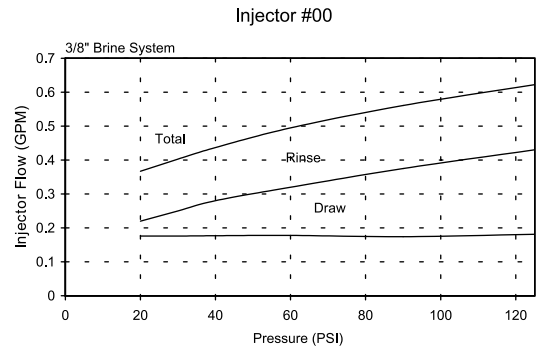
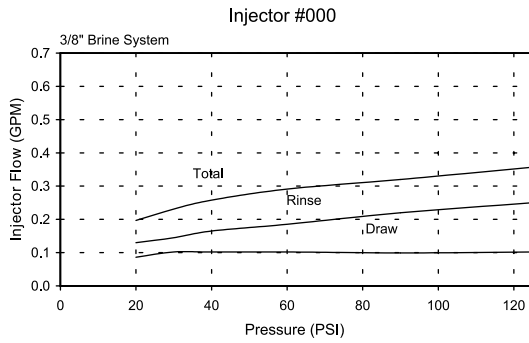

A) Total Flow, 3/8" Brine System B) Total Flow, 1/2" Brine Line C) Rinse D) Brine Draw, 3/8" Brine System E) Brine Draw, 1/2" Brine Line  
**NOTE: All data taken with 2310 Safety Brine Valve and 500 Air Check**

---

**Notes**

---



