

3200NT Timer

Service Manual

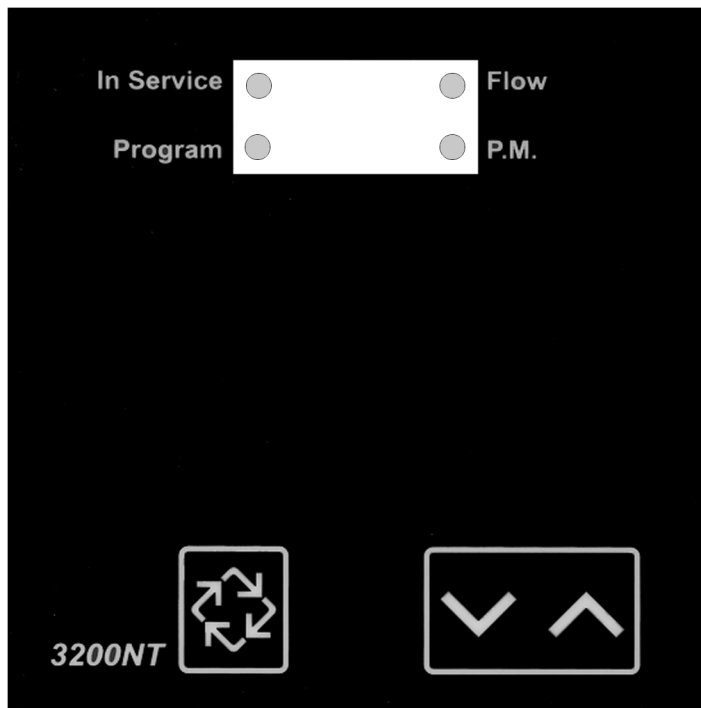

41025
NT001-0

Valve Serial Number _____

Valve Position

1-LEAd

2-LAg

3-LAg

4-LAg

IMPORTANT: Fill in pertinent information on *page 3* for future reference.

3200NT Timer

Table of Contents

Job Specifications Sheet	3
Timer Operation	4
<i>Set Time of Day</i>	4
<i>Manually Initiating a Regeneration</i>	4
<i>Timer Operation During Regeneration</i>	4
<i>Start a Regeneration Tonight</i>	4
<i>Day Regeneration Timer</i>	4
<i>Flow Meter Equipped Timer</i>	4
<i>Immediate Regeneration Timer with Regeneration Day Override Set</i>	5
<i>Delayed Regeneration Timer with Regeneration Day Override Set</i>	5
<i>Timer Operation During Programming</i>	5
<i>Timer Operation During A Power Failure</i>	5
<i>Remote Lockout</i>	5
<i>Remote Signal Start Regeneration</i>	5
<i>Day Override Feature</i>	5
System Operations	6
<i>System 4</i>	6
<i>System 5</i>	6
<i>System 6</i>	6
<i>System 7</i>	7
<i>System 9</i>	7
<i>Important System Operations Tips</i>	7
Timer Displays	8
<i>Timer Display Description</i>	8
Timer Programming Mode	9
Timer Display Definitions and Examples	10
Transformer Installation	11
<i>Installing the Transformer</i>	11
Power Head Assembly, 2750/2850/2900 Upper Drive and 2900 Lower Drive	12
Power Head Assembly Parts List 2750/2850/2900 Upper Drive and 2900 Lower Drive	13
Power Head Assembly, 3150/3900 Upper Drive and 3900 Lower Drive	14
Power Head Assembly Parts List, 3150/3900 Upper Drive and 3900 Lower Drive	15
2750/2850/3150 Timer Wiring Diagram	16
2750/2850/3150 Timer Wiring Diagram Labels	17
2900/3900 Timer Wiring Diagram	18
2900/3900 Timer Wiring Diagram Labels	19
Network Timer System Configuration Wiring Diagrams	20
<i>Interlocking 3200NT</i>	20
Troubleshooting	21
<i>Communication Error</i>	21
<i>Programming Error</i>	22
<i>Simultaneous Communication and Programming Errors</i>	22

IMPORTANT: The information, specifications and illustrations in this manual are based on the latest information available at the time of printing. The manufacturer reserves the right to make changes at any time without notice.

Job Specifications Sheet

Please circle and/or fill in the appropriate data for future reference.

Programming Mode:

Feed Water Hardness _____ Grain Per Gallon or _____ Degrees
 Regeneration Time: Delayed _____ a.m. / p.m. or Immediate
 Regeneration Day Override Off or Every _____ Days

Master Programming Mode:

Valve Model	2750	2850	2900	2930	3130	3150	3900
Regeneration Type	Downflow	Upflow Brine Draw First			Upflow Brine Fill First		
System Type	4 Time Clock	4 Meter Immediate		4 Meter Delayed			
	5 Interlock	6 Series	7 Alternating		9 Alternating		
Valve Position	LEAd	or	LAg				
Remote Signal Start	Off	or	On	Signal Time needed _____ Minutes			
Display Format	US Gallons	or	m ³				
System Capacity	_____		Gallons	or	m ³		
Capacity Safety Factor	Zero	or	____%				
Regeneration Cycle Step #1			____ Minutes				
Regeneration Cycle Step #2	Off	or	____ Minutes				
Regeneration Cycle Step #3	Off	or	____ Minutes				
Regeneration Cycle Step #4	Off	or	____ Minutes				
Regeneration Cycle Step #5	Off	or	____ Minutes				
Regeneration Cycle Step #6	Off	or	____ Minutes				
Time Auxiliary Relay Output							
Window #1	Off	or	Start Time _____				
			End Time _____				
Time Auxiliary Relay Output							
Window #2	Off	or	Volume _____				
			Seconds _____				
Fleck Flow Meter size	1"	1.25"	1.5"	2"	3" or	Non Fleck _____ Pulses	
Line Frequency	50Hz	or	60Hz				

3200NT Timer

Timer Operation

Set Time of Day

When the timer is **In Service**, push either the **Set Up** or **Set Down** button once to adjust the **Time of Day** by one digit. Push and hold to adjust by several digits.

Manually Initiating a Regeneration

1. When timer is **In Service**, press the **Extra Cycle** button for 5 seconds to force a manual regeneration.
2. The timer reaches **Regeneration Cycle Step #1**.
3. Press the **Extra Cycle** button once to advance valve to Regeneration Cycle Step #2 (if active).
4. Press the **Extra Cycle** button once to advance valve to Regeneration Cycle Step #3 (if active).
5. Press the **Extra Cycle** button once to advance valve to Regeneration Cycle Step #4 (if active).
6. Press the **Extra Cycle** button once to advance valve to Regeneration Cycle Step #5 (if active).
7. Press the **Extra Cycle** button once more to advance the valve back to **In Service**

Timer Operation During Regeneration

In the **Regeneration Cycle** step display, the timer shows the current regeneration step number the valve is advancing to, or has reached, and the time remaining in that step. The step number that displays flashes until the valve completes driving to this regeneration step position. Once all regeneration steps are complete the timer returns to **In Service** and resumes normal operation.

Example:

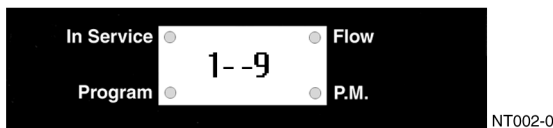

Less than 10 Minutes Remaining in Regen Step #1



Press the **Extra Cycle** button during a **Regeneration Cycle** to immediately advance the valve to the next cycle step position and resume normal step timing.

Start a Regeneration Tonight

With metered delayed timers, press the **Extra Cycle** button momentarily. The **In Service** indicator dot flashes and starts a **Regeneration** tonight at the programmed **Regeneration Time**.

Day Regeneration Timer

During normal operation the **Time of Day** display is visible at all times. The timer operates normally until the number of days since the last regeneration reaches the **Regeneration Day Override** setting. Once this occurs, a regeneration cycle is initiated at the preset **Regeneration Time**.

Flow Meter Equipped Timer

During normal operation the **Time of Day** display alternates with the **Volume Remaining** display (gallons or m³).

- As treated water is used, the **Volume Remaining** display counts down from the calculated system capacity to zero or (---). When this occurs a **Regeneration Cycle** begins or delays to the set Regeneration Time.
- Water flow through the valve is indicated by the Flow Dot that flashes in a direct relationship to flow rate.

Timer Operation

Immediate Regeneration Timer with Regeneration Day Override Set

When the valve reaches the set **Days Since Regeneration Override** value, a **Regeneration Cycle** initiates immediately. This occurs even if the **Volume Remaining** display has not reached zero.

Delayed Regeneration Timer with Regeneration Day Override Set

When the timer reaches the set **Days Since Regeneration Override** value a **Regeneration Cycle** initiates at the preset **Regeneration Time**. This occurs even if the **Volume Remaining** display has not reached zero.

Timer Operation During Programming

The timer only enters the Program Mode with the timer **In Service**. While in the Program Mode the timer continues to operate normally monitoring water usage and keeping all displays up to date. Timer programming is stored in memory permanently. There is no need for battery backup power.

Timer Operation During A Power Failure

During a power failure all timer displays and programming are stored for use upon power re-application. The timer retains all values, without loss. The timer is fully inoperative and any calls for regeneration are delayed. The timer, upon power re-application, resumes normal operation from the point that it was interrupted.

NOTE: An inaccurate **Time of Day** display may indicate a power outage.

Remote Lockout

The timer does not allow the unit/system to go into **Regeneration** until the Regeneration Lockout Input signal to the unit/system is cleared. This requires a contact closure to activate. See wiring diagrams *Figure 6, page 16* and *Figure 7, page 18*.

Remote Signal Start Regeneration

The control valve monitors treated water other than a flow meter. The timer receives a wetted contact signal for the amount of programmed time to receive. Regeneration begins immediately after signal is done.

Day Override Feature

If the **Day Override** option is turned on and the valve reaches the set Regeneration Day Override value without the water meter initiating a **Regeneration Cycle**, a **Regeneration Cycle** queues. This occurs regardless of the remaining volume available.

	<p>WARNING Transformer must be grounded and ground wire must be terminated to the back plate where grounding label is located before installation. See instructions for <i>Installing and Grounding the Transformer, page 11</i>.</p>
---	--

3200NT Timer

System Operations

System 4

Time Clock (1 Valve)

During normal operation the **Time of Day** display may be viewed at all times. The control operates normally until the number of days since the last regeneration reaches the **Regeneration Day Override** setting. Once this occurs, a **Regeneration Cycle** initiates at the preset **Regeneration Time**.

Meter Delayed (1 Valve)

During normal operation the **Time of Day** display alternates with the **Volume Remaining** display (gallons or m³).

- As treated water is used, the **Volume Remaining** display counts down from the calculated system capacity.
- The system monitors the volume of water used. When the system calculates that there is not a sufficient capacity for the next day's operation, a regeneration cycle is initiated at the preset regeneration time.
- Water flow through the valve is indicated by the Flow Dot that flashes in a direct relationship to flow rate.

Meter Immediate (1 Valve)

During normal operation the **Time of Day** display alternates with the **Volume Remaining** display (gallons or m³).

- As treated water is used, the **Volume Remaining** display counts down from the calculated system capacity to zero or (----). When this occurs a **Regeneration Cycle** is started.
- Water flow through the valve is indicated by the Flow Dot that flashes in a direct relationship to flow rate.

System 5

Interlock (2 – 4 Valves)

During normal operation the **Time of Day** display alternates with the **Volume Remaining** display (gallons or m³).

- As treated water is used, the **Volume Remaining** display counts down from the calculated system capacity to zero or (----). When this occurs a **Regeneration Cycle** queues.
- If no other valve is in **Regeneration** the valve sends a lock command and starts a **Regeneration Cycle**.
- If another valve is in **Regeneration** (i.e. the system is already locked) the valve remains **In Service** with **Regeneration** queued until other valves complete **Regeneration**. Then the system locks and **Regeneration** begins.
- Water flow through the valve is indicated by the Flow Dot that flashes in a direct relationship to flow rate.

System 6

Series (2 – 4 Valves)

During normal operation the **Time of Day** display alternates with the **Volume Remaining** display (gallons or m³). The **Volume Remaining** is the total volume for all units in the system.

- As treated water is used, the **Volume Remaining** display counts down from the calculated system capacity to zero or (----). When this occurs a **Regeneration Cycle** queues.
- If no other valve is in regeneration the valve sends a lock command and starts a **Regeneration Cycle**.
- If another valve is in regeneration (i.e. the system is already locked) the valve remains **In Service** until other valves complete regeneration, then regeneration is queued. The LEAd valve locks the system and **Regeneration** begins.
- When the LEAd valve completes regeneration cycle the remaining valve(s) in the system regenerate sequentially until all valves regenerate.
- Water flow through the valve is indicated by the Flow Dot that flashes in a direct relationship to flow rate.
- LAg valve volume remaining is updated every 5 seconds from the LEAd valve.
- A manually forced regeneration (EC key) can only be done on the LEAd valve and only if the system is not in **Regeneration**.

System Operations

System 7

Alternating (2 Valves)

During normal operation the **Time of Day** display alternates with the **Volume Remaining** display (gallons or m³). The **Volume Remaining** is the total volume for all units in the system.

- As treated water is used, the **Volume Remaining** display counts down from the calculated system capacity to zero or (----). When this occurs a **Regeneration Cycle** queues.
- The valve requiring **Regeneration** sends a lock command to the standby valve. The standby valve goes to **In Service** and exhausted valve starts a **Regeneration Cycle**.
- If a valve is in **Regeneration** and the other valve exhausts its volume remaining, then the exhausted valve remains **In Service** with **Regeneration** queued until the other valve goes into standby. The exhausted valve goes into standby after completing **Regeneration**.
- Water flow through the valve is indicated by the Flow Dot that flashes in a direct relationship to flow rate.

System 9

Alternating (2 – 4 Valves)

During normal operation the **Time of Day** display alternates with the **Volume Remaining** display (gallons or m³). The **Volume Remaining** is the total volume for all units in the system.

- As treated water is used, the **Volume Remaining** display counts down from the calculated system capacity to zero or (----). When this occurs a **Regeneration Cycle** queues.
- The valve requiring **Regeneration** sends a lock command to the standby valve. The standby valve goes to **In Service** and exhausted valve starts a **Regeneration Cycle**.
- If a valve is in **Regeneration** and another valve exhausts its volume remaining, then the exhausted valve remains **In Service** with **Regeneration** queued until the other valve goes into standby. The exhausted valve goes into standby after completing **Regeneration**.
- All units remain **In Service** except those in standby or **Regeneration**.
- Water flow through the valve is indicated by the Flow Dot that flashes in a direct relationship to flow rate.

Important System Operations Tips

- When programming multi-unit systems, program LAg units first and then LEAd unit. This eliminates or minimizes lower drive movement due to system type changes and errors.
 - When changing a valve from one system type to another system type, perform a Master Reset first.
 - System 6, 7 and 9 valves coming out of program mode or on power-up calculate their volume (display = **CALC**) and then wait for a good communication signal.
 - When a good communication signal is received, the system resume normal operations.
 - If the system does not receive a good communication signal, **CALC** displays and the system goes into a wait. Press the EC key to force the system out of the wait and resume normal operation.
 - The System 4, 5 and 6 LEAd valve drive sequence going into **Regeneration** is:
 - The lower drive moves to off-line and the upper drive moves to first **Regeneration** position.
- System 6 LAg valves and all system 7 and 9 valves:
- The off-line valve moves to online, the valve requiring **Regeneration** moves its lower drive to off-line and then the upper drive moves to first **Regeneration** position.
- Reserve capacity—System 4Fd only. After power-up or Master Reset, the reserve is set to one-third of the calculated capacity. Reserve is limited to a range of zero—capacity.
 - System 6 and 7, LEAd units only, respond to remote lock and chemical pump. Also chemical pump is available only if the auxiliary relay in regeneration is not used [**AroF**]

3200NT Timer

Timer Displays

Timer Display Description

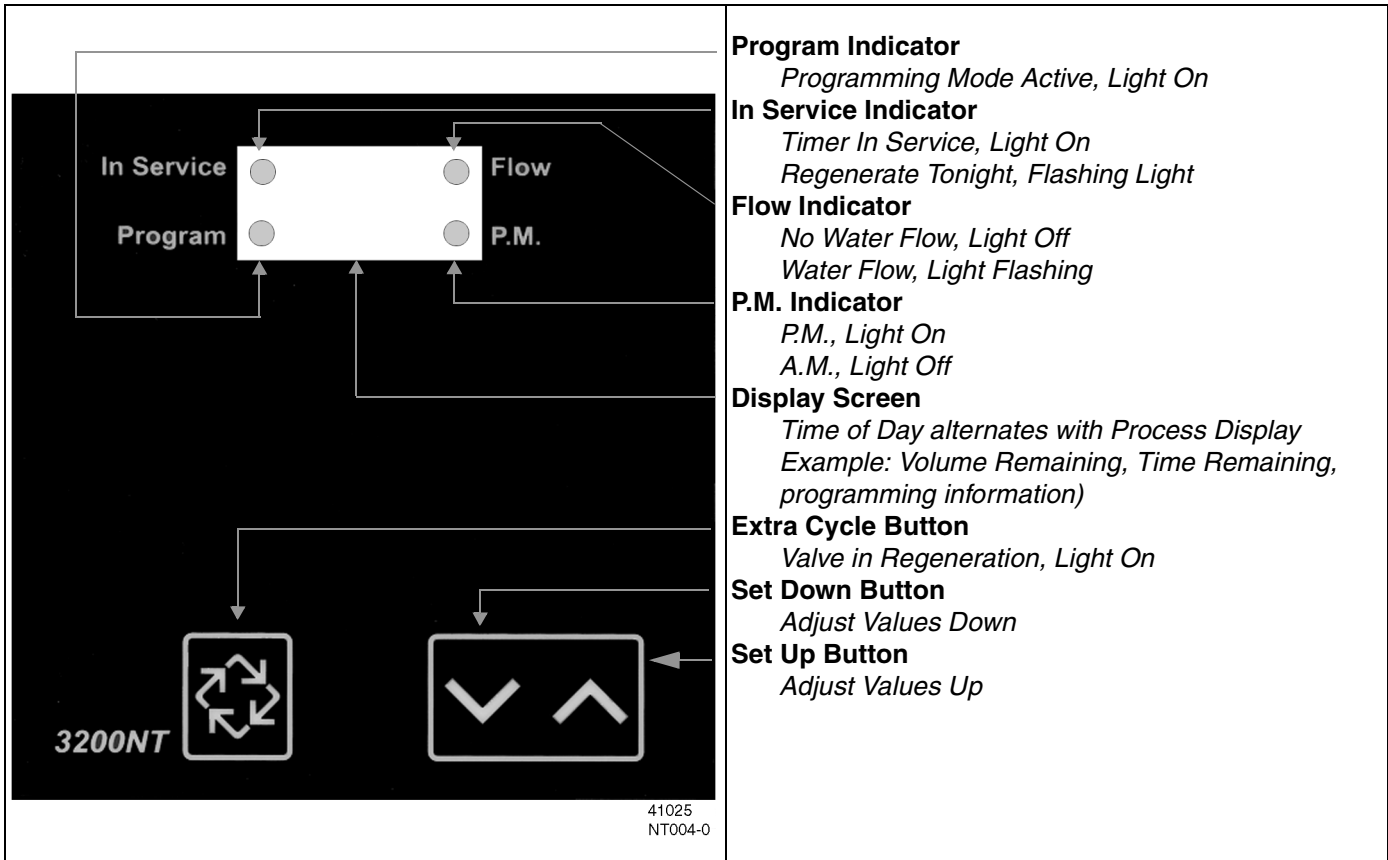
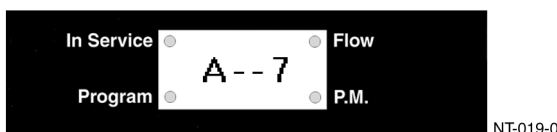
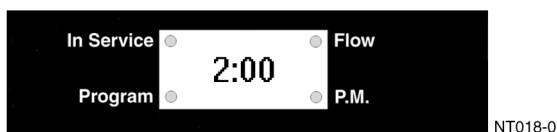

Figure 1: Control Panel and Display

Timer Programming Mode



1. Enter 3200NT Programming Mode

Press and hold both the **Set Up** and **Set Down** buttons for five (5) seconds to enter Programming Mode. When the program mode is entered, the program light illuminates.

2. Set Feed Water Hardness

The feed water hardness setting displays only if the Regeneration Type is set to Meter Immediate or Meter Delayed.

- Press the **Set Up** and **Set Down** buttons to set the amount of feed water hardness (in grains/gallon). The system automatically calculates treated water capacity based on the feed water hardness and the system capacity.
- Press the **Extra Cycle** button to proceed to the next step.

3. Set Regeneration Time

A non-flashing colon between two sets of numbers identifies the **Regeneration Time** display. Set the desired time of day that you want **Regeneration** to occur.

- Press the **Set Up** and **Set Down** buttons to adjust this value.
- Press the **Extra Cycle** button to proceed to the next step.

4. Set Regeneration Day Override

Use this display to set the maximum amount of time (in days) the unit can be **In Service** without a **Regeneration**.

- For System 4 Time Clock regeneration mode the system regenerates at the time set in Step 4 after the number of days programmed in this step.
- For all other System Types (4 Meter Immediate, 4 Meter Delayed, 5, 6, 7, 9) the system regenerates after the number of days programmed in this step unless the meter initiates a **Regeneration** cycle earlier.
- Press the **Extra Cycle** button to proceed to the next step.

Timer programming is complete and exits from the Programming Mode. Normal operation resumes.

3200NT Timer

Timer Display Definitions and Examples

Time of Day



NT005-0

US format



NT007-0

m³ format

Treated Water Remaining (4 Digit)



NT006-0



NT006-0

Treated Water Remaining (Over 4 Digits) t = (X 1000)

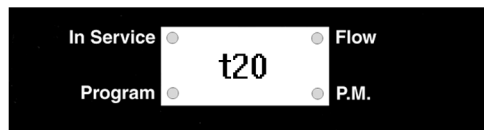

NT008-0

US format

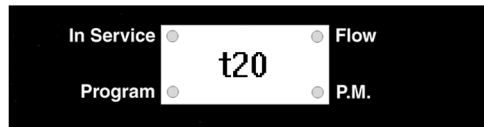

NT008-0

m³ format

Zero Treated Water Remaining

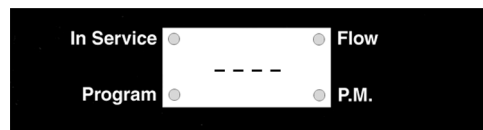

NT009-0



NT009-0

Communication Error

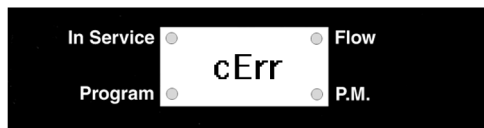

NT010-0

Calculating The Volume Remaining



NT011-0

Programming Error



NT012-0

Timer is Lock Out



NT013-0

Remote Signal Start Signal Is Communicating

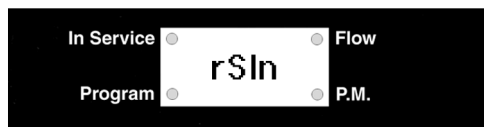

NT014-0

Timer is Remotely Lock Out



NT015-0

Transformer Installation

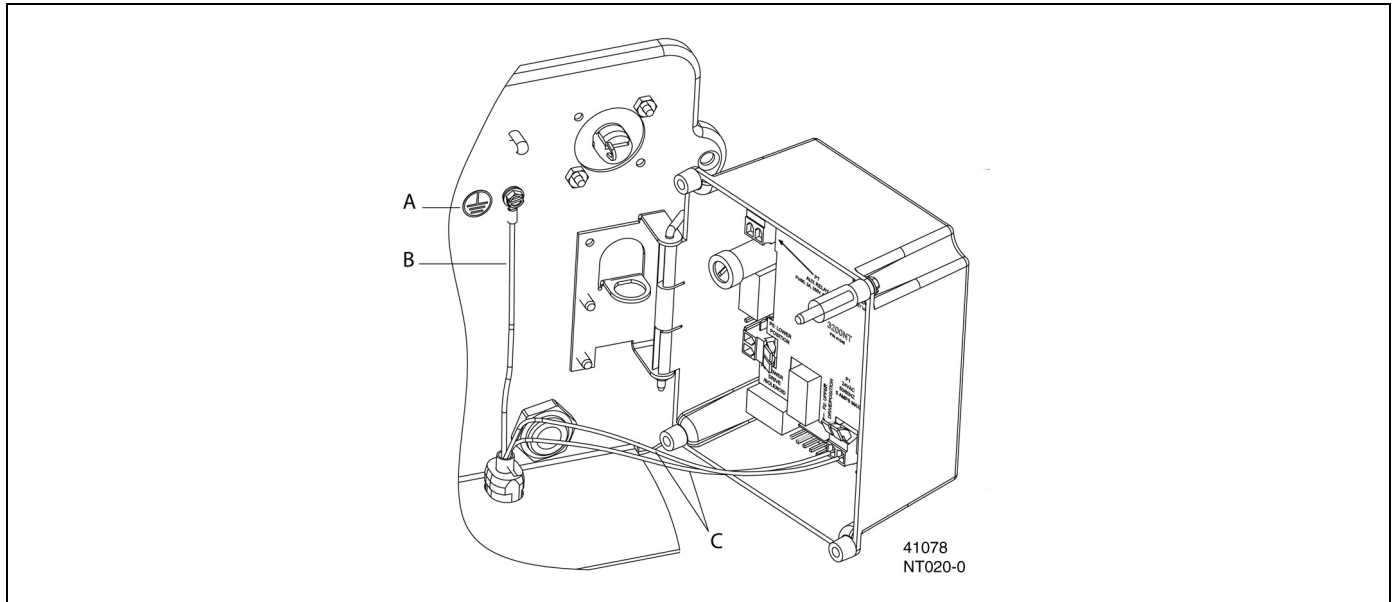

Figure 2: Installing Ground Wire on Transformer, **2750/2850/2900** Valves

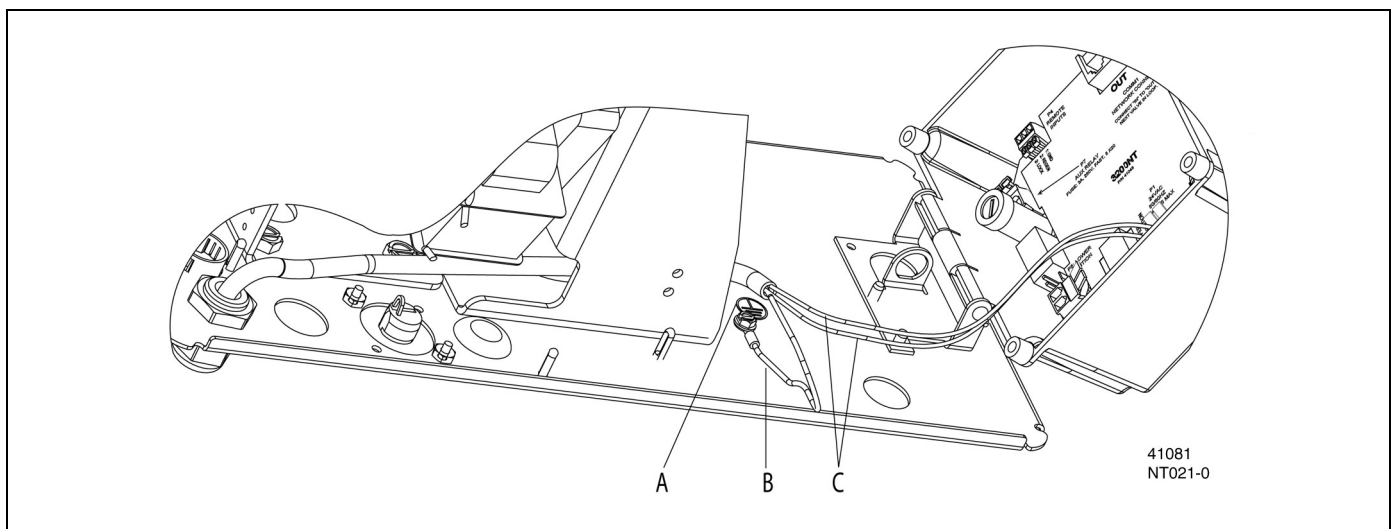

Figure 3: Installing Ground Wire on Transformer, **3150/3900** Valves

<i>Item</i>	<i>Description</i>
A	ground label
B	ground wire from transformer
C	wires from transformer

Installing and Grounding the Transformer

1. Locate the ground label (A) to find ground screw.
2. Remove the screw and attach the transformer ground wire (B).
3. Re-attach the screw.

3200NT Timer

Power Head Assembly

2750/2850/2900 Upper Drive and 2900 Lower Drive

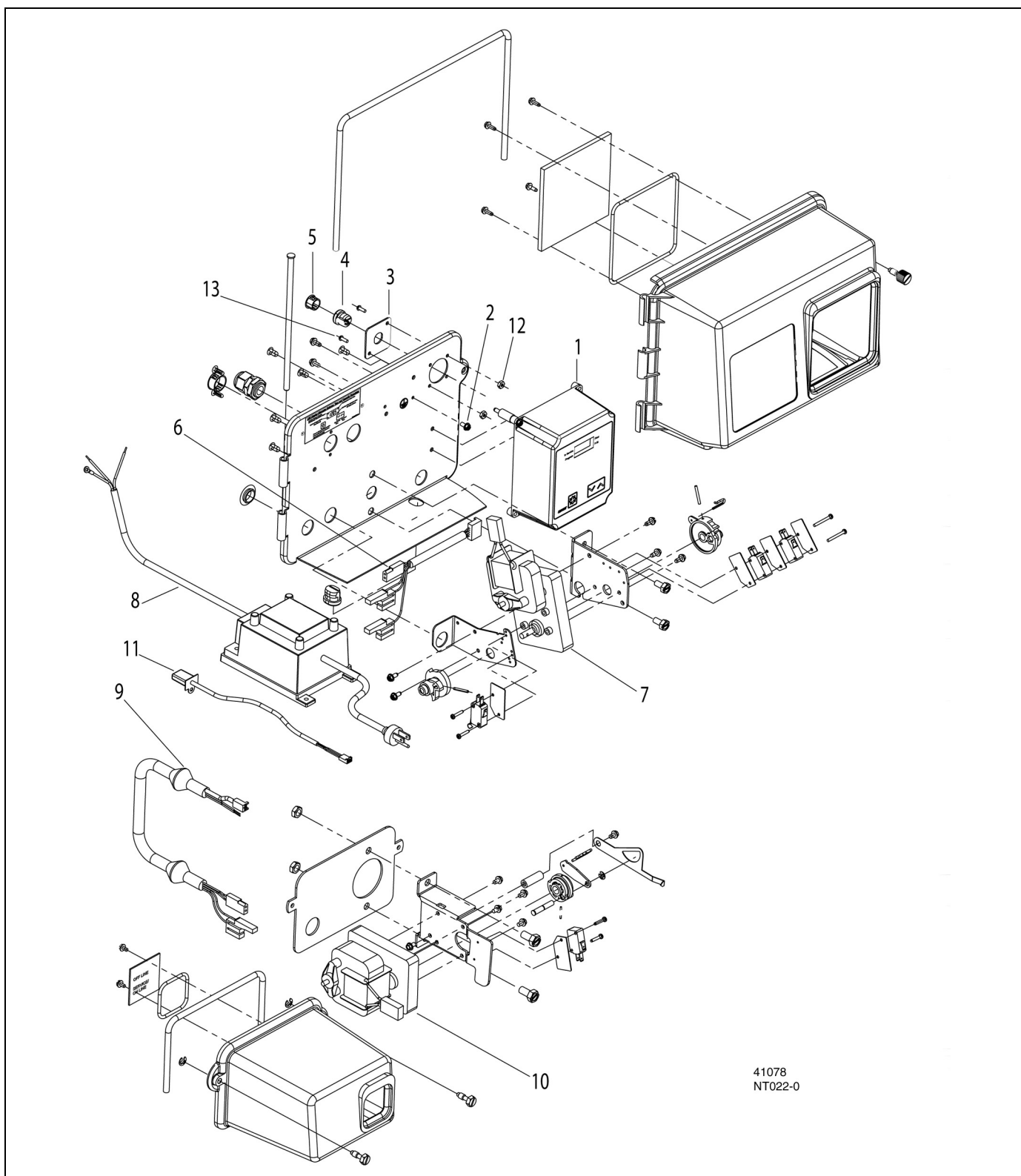

Figure 4: 2750/2850/2900 Upper Drive and 2900 Lower Drive Power Head Assembly

Power Head Assembly Parts List *2750/2850/2900 Upper Drive and 2900 Lower Drive*

<i>Item</i>	<i>Quantity</i>	<i>Part Number</i>	<i>Description</i>
1	1	41062	3200NT timer assembly
2	1	14202-01	screw, slotted hex washer head, #8-32 x .31
3	1	40959	bracket, strain relief, EZ NET
4	1	41071	bushing, strain relief
5	1	41035	plug, strain relief
6	1	40941	harness, upper drive
7	1	40385	motor, drive, 24V 50/60 Hz
8	1	41034	transformer, 120 / 24V, US
	1	41049	transformer, 230V/24V, European
	1	41050	transformer, 230V/24V, Australian
9	1	40943	harness, lower drive
10	1	40388	motor, drive, 24V 50/60 Hz
11	1	19121-05	meter cable assembly, 35"
	1	19121-07	meter cable assembly, 99.5"
	1	19121-08	meter cable assembly, 303.5"
12	2	12732	nut, hex, machine, #5-40
13	2	10299	screw, slotted round head, #5-40 x .38

NOTE: For all other service part numbers, see the Service Manual that accompanies the control valve.

3200NT Timer

Power Head Assembly, 3150/3900 Upper Drive and 3900 Lower Drive

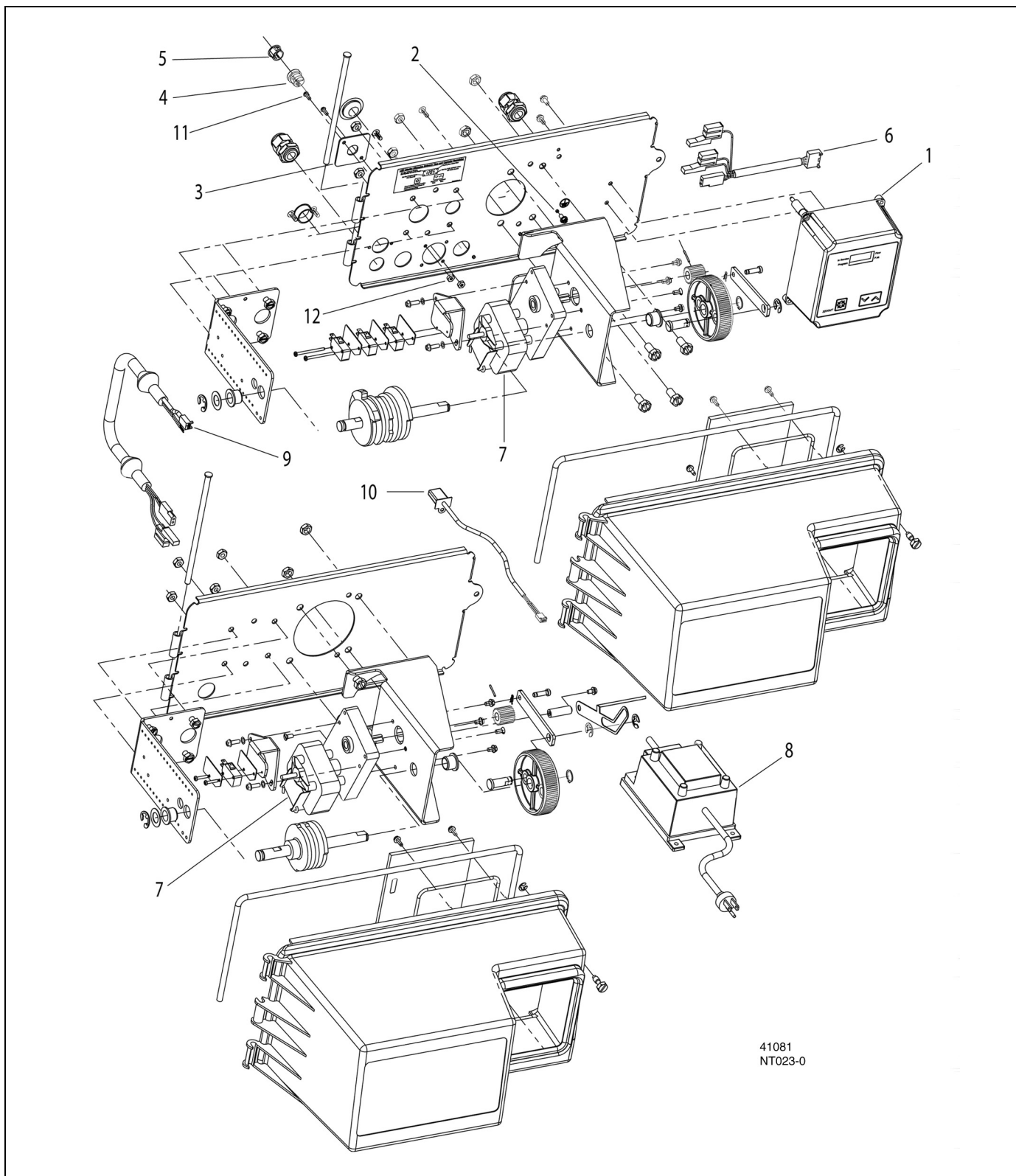

41081
NT023-0

Figure 5: 3150/3900 Upper Drive and Lower Drive Power Head Assembly

Power Head Assembly Parts List, 3150/3900 Upper Drive and 3900 Lower Drive

<i>Item</i>	<i>Quantity</i>	<i>Part Number</i>	<i>Description</i>
1	1	41062	3200NT timer assembly
2	1	14202-01	screw, slotted, hex washer head, #8-32 x .31
3	1	40959	bracket, strain relief, EZ NET
4	1	41071	bushing, strain relief
5	1	41035	plug, strain relief
6	1	40941	harness, upper drive
7	2	40391	motor, drive, 24V, 50/60 Hz
8	1	41034	transformer, 120V/24V
	1	41049	transformer, 230V/24V, European
	1	41050	transformer, 230V/24V, Australian
9	1	40943	harness, lower drive
10	1	19121-05	meter cable assembly, 35"
	1	19121-07	meter cable assembly, 99.5"
	1	19121-08	meter cable assembly, 303.5"
11	2	10299	screw, slotted round head, #5-40 x .375
12	2	12732	nut, hex, machine, #5-40

NOTE: For all other service part numbers, see the Service Manual that accompanies the control valve.

3200NT Timer

2750/2850/3150 Timer Wiring Diagram

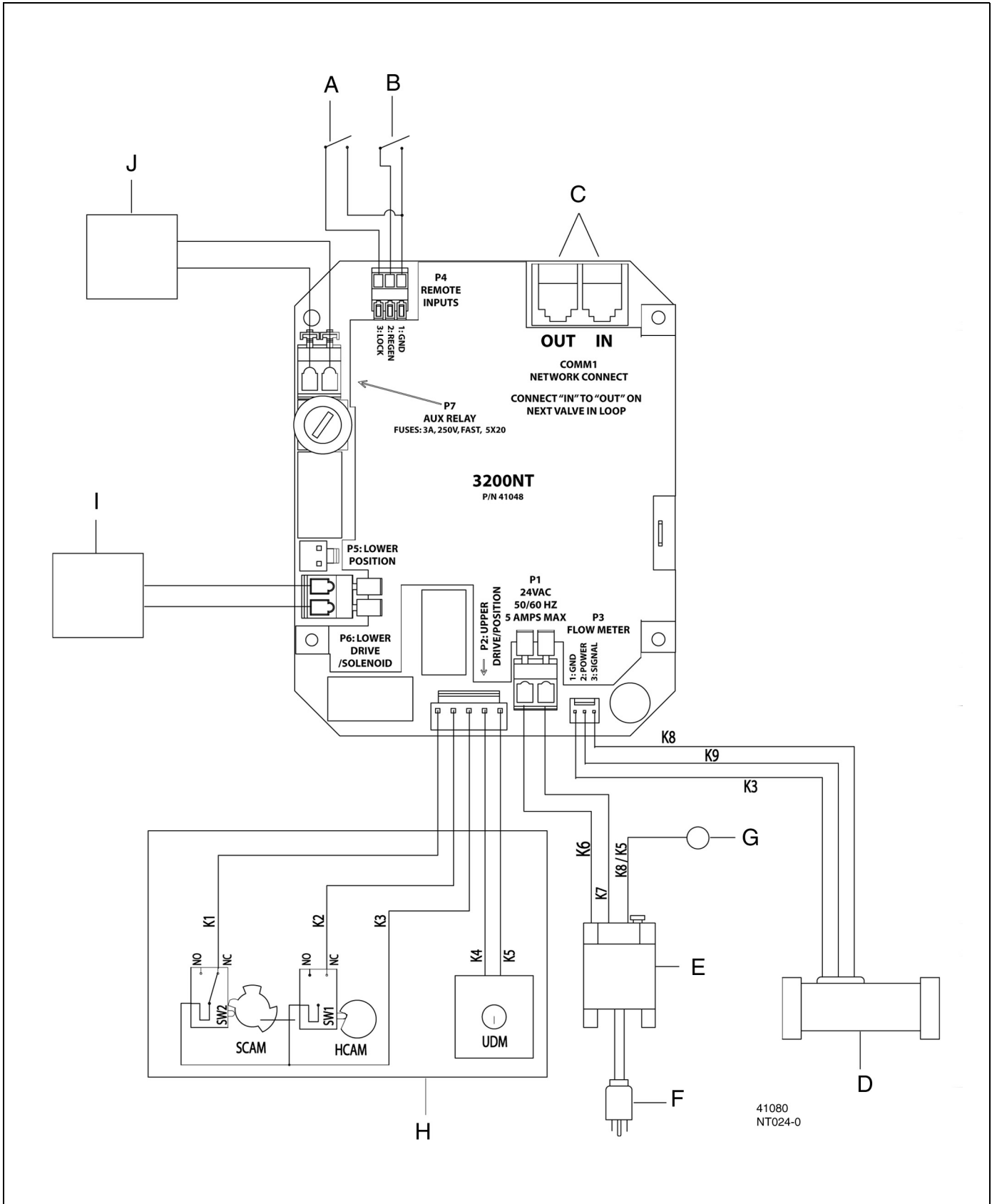

Figure 6: 2750/2850/3150 Timer Wiring Diagram, System #4—Single Valve Regeneration

2750/2850/3150 Timer Wiring Diagram Labels

<i>Item</i>	<i>Description</i>
A	remote lock out input — closed contact locks In Service
B	remote signal start input — closed contact initiates regeneration
C	network communication output and input — See network timer system wiring diagrams <i>Figure 8, Figure 9 and Figure 10, page 20.</i>
D	flow meter, if used
E	transformer
F	grounded plug
G	earth ground screw on base plate — fuse: 5A Slo Blo
H	upper drive assembly UDM Upper Drive Motor LDM Lower Drive Motor HCAM Valve Homing Cam SCAM Valve Step Cam SW1 Valve Homing Switch SW2 Valve Step Switch SW3 Lower Drive Switch NO Normally Open NC Normally Closed
	Note: Meter delayed or meter immediate regeneration
I	solenoid connection solenoid: 24VAC, normally open maximum watt rating: 6.1 VA holding: 16 VA inrush: 30 — Used in System 7 and 9
J	timed auxiliary relay programmable, normally open, relay contacts used in Regeneration and/or In Service maximum rated load: 3A @ 250VAC resistive 3A @ 30VDC resistive fused: 3A, 250V fast 5X20
K	Colors
K1	Purple
K2	Orange
K3	Black
K4	White
K5	Yellow
K6	Brown
K7	Blue
K8	Green
K9	Red

3200NT Timer

2900/3900 Timer Wiring Diagram

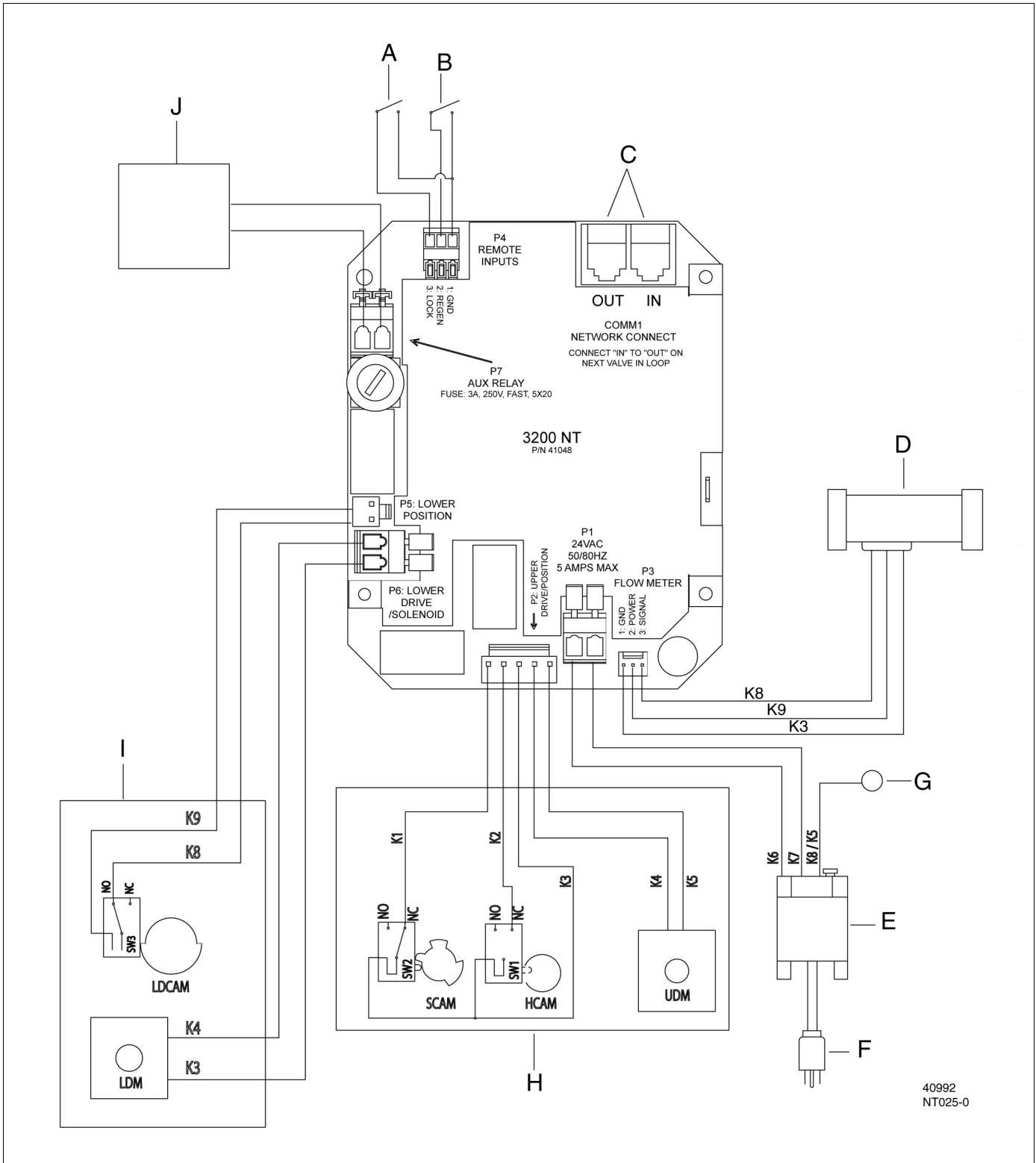

Figure 7: 2900/3900 Timer Wiring Diagram, System #4—Single Valve Regeneration

2900/3900 Timer Wiring Diagram Labels

<i>Item</i>	<i>Description</i>
A	remote lock out input — closed contact locks In Service
B	remote signal start input — closed contact initiates regeneration
C	network communication output and input — See network timer system wiring diagrams <i>Figure 8, Figure 9 and Figure 10, page 20.</i>
D	flow meter, if used
E	transformer
F	grounded plug
G	earth ground screw on base plate fuse: 5A Slo Blo
H	upper drive assembly UDM Upper Drive Motor LDM Lower Drive Motor HCAM Valve Homing Cam SCAM Valve Step Cam SW1 Valve Homing Switch SW2 Valve Step Switch SW3 Lower Drive Switch NO Normally Open NC Normally Closed
	Note: Meter delayed or meter immediate regeneration
I	lower drive LDCAM Lower Drive Cam
J	timed auxiliary relay programmable, normally open relay contacts used in Regeneration and/or In Service maximum rated load: 3A @ 250VAC resistive 3A @ 30VDC resistive fused: 3A, 250V fast 5X20
K	Colors
K1	Purple
K2	Orange
K3	Black
K4	White
K5	Yellow
K6	Brown
K7	Blue
K8	Green
K9	Red

Network Timer System Configuration Wiring Diagrams

Two Timers

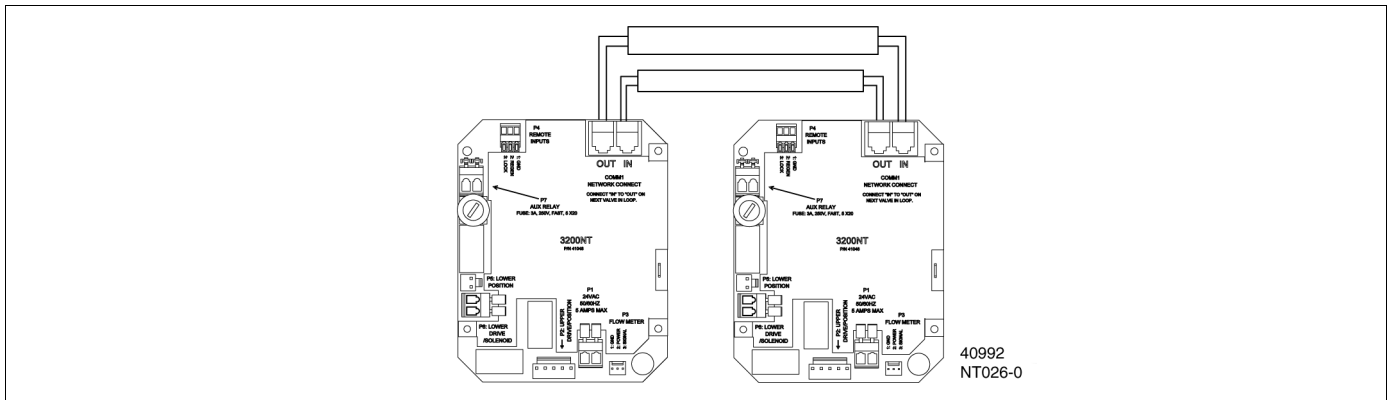

Figure 8: Network Timer System Wiring Diagram for System 5, 6, 7 and 9 Duplex

Three Timers

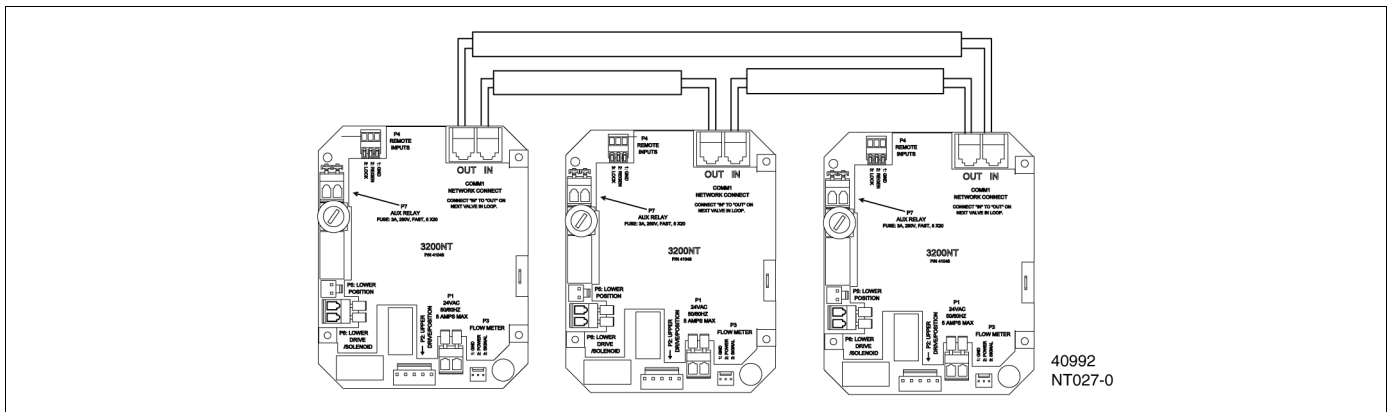

Figure 9: Network Timer System Wiring Diagram for System 5, 6 and 9 Triplex

Four Timers

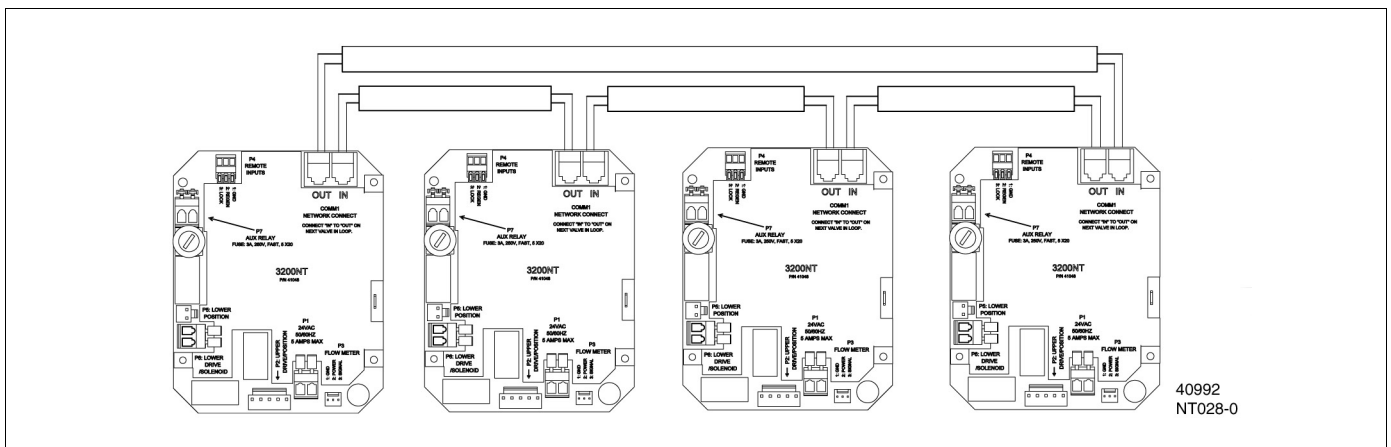

Figure 10: Network Timer System Wiring Diagram for System 5, 6 and 9 Quadplex

Interlocking 3200NT

NOTE: Use only 6-place, 4-conductor, RJ45 phone or extension cables.

1. Connect phone or extension cables first before programming.
 - System Type 7 and 6: flow meter cable must be connected to the timer programmed as the LEAd Timer.
2. A maximum cable length of 25' cable can be used between timers.
3. Always connect "IN" communication port to the "OUT" communication port of the next timer. Connect the last timer back to the first timer.

Troubleshooting

Communication Error

If a communication error is detected, **cErr** displays. It may take several minutes for all of the units in a system to display the error message.

- All units **In Service** remain in the **In Service** position.
- All units in standby go to **In Service**.
- Any unit in regeneration when the error occurs completes regeneration and goes to **In Service**.
- No units are allowed to start a regeneration cycle while the error condition exists.
- When the communication problem is corrected and the error no longer displays (it may take several minutes for all of the units in a system to stop displaying the error message), the system returns to normal operation.

NOTE: During the error condition the control continues to monitor the flow meter and update the remaining volume. Once the error condition is corrected all units return to the operating status they were in prior to the error and regeneration is queued according to the normal system operation. If reprogramming the unit in the Master Programming Mode clears the error, the volume remaining may be reset to the full unit capacity (i.e. as though it were just regenerated).

NOTE: System 4 units retain their normal display and do not display **cErr**.

Cause	Correction
A. One or more units have a missing or bad communication cable.	A. Connecting the communication cables.
B. One or more units has a communication cable plugged into the wrong receptacle.	B. Connecting the communication cable as shown on the wiring diagrams.
C. One or more units is not powered.	C. Powering all units.
D. One or more of the units programmed as a stand alone system 4tc, 4FI or 4Fd and one or more units programmed as a multi-unit system 5FI, 6FI, 7FI or 9FI.	D. Programming the units for the same system type in the Master Programming Mode.
E. All of the units programmed as LAg. With no unit programmed as a LEAd (there is no unit to start the communications).	E. Programming the units correctly in the Master Programming Mode.

Troubleshooting

Programming Error

Units display **PErr** when a programming error occurs.

- If multiple units are programmed as LEAd, **PErr** displays on all units.
- All units **In Service** remain in the **In Service** position.
- All units in standby go to **In Service**.
- Any unit in regeneration when the error occurs completes regeneration and goes to **In Service**.
- No units are allowed to start a regeneration cycle while the error condition exists.
- When the problem is corrected and the error no longer displays (it may take several minutes for all of the units in a system to stop displaying the error message), the system returns to normal operation.

NOTE: During the error condition the control continues to monitor the flow meter and update the remaining capacity. Once the error condition is corrected all units return to the operating status they were in prior to the error and regeneration is queued according to the normal system operation. If reprogramming the unit in the Master Programming Mode clears the error, the volume remaining may be reset to the full unit capacity (i.e. as though it were just regenerated).

NOTE: System 4 units retain their normal display and do not display **PErr**.

Cause	Correction
A. One or more units programmed as System type different from the LEAd unit.	A. Programming the units correctly in the Master Programming Mode.
B. More than one unit programmed as the S unit.	B. Programming the units correctly in the Master Programming Mode.
C. One or more units programmed with different hardness, day override or line frequency values.	C. Program these values to be the same on all units.

Simultaneous Communication and Programming Errors

If both a communication and programming errors occur simultaneously, the communications error (**cErr**) has precedence and masks the programming error (**PErr**). When the communications error (**cErr**) is corrected, the programming error (**PErr**) displays until corrected.

