



*Thinking of you*  
**Electrolux**



EN3700AHW  
ERB34258W

.....  
**EN FRIDGE FREEZER**

.....  
**USER MANUAL**



## CONTENTS

SAFETY INFORMATION . . . . .	3
CONTROL PANEL . . . . .	6
DAILY USE . . . . .	8
HELPFUL HINTS AND TIPS . . . . .	10
CARE AND CLEANING . . . . .	12
WHAT TO DO IF... . . . .	14
INSTALLATION . . . . .	17
NOISES . . . . .	21
TECHNICAL DATA . . . . .	22
ENVIRONMENT CONCERNS . . . . .	23

## WE'RE THINKING OF YOU

Thank you for purchasing an Electrolux appliance. You've chosen a product that brings with it decades of professional experience and innovation. Ingenious and stylish, it has been designed with you in mind. So whenever you use it, you can be safe in the knowledge that you'll get great results every time.

Welcome to Electrolux.

### Visit our website for:



Get usage advice, brochures, trouble shooter, service information:  
[www.electrolux.com](http://www.electrolux.com)



Register your product for better service:  
[www.electrolux.com/productregistration](http://www.electrolux.com/productregistration)



Buy Accessories, Consumables and Original spare parts for your appliance:  
[www.electrolux.com/shop](http://www.electrolux.com/shop)

## CUSTOMER CARE AND SERVICE

We recommend the use of original spare parts.

When contacting Service, ensure that you have the following data available.

The information can be found on the rating plate. Model, PNC, Serial Number.



Warning / Caution-Safety information



General information and tips



Environmental information

Subject to change without notice.



## SAFETY INFORMATION

In the interest of your safety and to ensure the correct use, before installing and first using the appliance, read this user manual carefully, including its hints and warnings. To avoid unnecessary mistakes and accidents, it is important to ensure that all people using the appliance are thoroughly familiar with its operation and safety features. Save these instructions and make sure that they remain with the appliance if it is moved or sold, so that everyone using it through its life will be properly informed on appliance use and safety.

For the safety of life and property keep the precautions of these user's instructions as the manufacturer is not responsible for damages caused by omission.

### CHILDREN AND VULNERABLE PEOPLE SAFETY

- This appliance is not intended for use by persons (including children) with reduced physical, sensory or mental capabilities, or lack of experience and knowledge, unless they have been given supervision or instruction concerning use of the appliance by a person responsible for their safety.

Children should be supervised to ensure that they do not play with the appliance.

- Keep all packaging well away from children. There is risk of suffocation.
- If you are discarding the appliance pull the plug out of the socket, cut the connection cable (as close to the appliance as you can) and remove the door to prevent playing children to suffer electric shock or to close themselves into it.
- If this appliance featuring magnetic door seals is to replace an older appliance having a spring lock (latch) on the door or lid, be sure to make that spring lock unusable before you discard the old appliance. This will prevent it from becoming a death trap for a child.

### GENERAL SAFETY



#### **WARNING!**

Keep ventilation openings, in the appliance enclosure or in the built-in structure, clear of obstruction.

- The appliance is intended for keeping foodstuff and/or beverages in a normal household as explained in this instruction booklet.
- Do not use a mechanical device or any artificial means to speed up the thawing process.
- Do not use other electrical appliances (such as ice cream makers) inside of refrigerating appliances, unless they are approved for this purpose by the manufacturer.
- Do not damage the refrigerant circuit.
- The refrigerant isobutane (R600a) is contained within the refrigerant circuit of the appliance, a natural gas with a high level of environmental compatibility, which is nevertheless flammable.

During transportation and installation of the appliance, be certain that none of the components of the refrigerant circuit become damaged.

If the refrigerant circuit should become damaged:

- avoid open flames and sources of ignition
- thoroughly ventilate the room in which the appliance is situated
- It is dangerous to alter the specifications or modify this product in any way. Any damage to the cord may cause a short-circuit, fire and/or electric shock.



#### **WARNING!**

Any electrical component (power cord, plug, compressor) must be replaced by a certified service agent or qualified service personnel to avoid hazard.

1. Power cord must not be lengthened.
2. Make sure that the power plug is not squashed or damaged by the back of the appliance. A squashed or damaged power plug may overheat and cause a fire.
3. Make sure that you can come to the mains plug of the appliance.
4. Do not pull the mains cable.

5. If the power plug socket is loose, do not insert the power plug. There is a risk of electric shock or fire.
  6. You must not operate the appliance without the lamp cover (if foreseen) of interior lighting.
- This appliance is heavy. Care should be taken when moving it.
  - Do not remove nor touch items from the freezer compartment if your hands are damp/wet, as this could cause skin abrasions or frost/freezer burns.
  - Avoid prolonged exposure of the appliance to direct sunlight.
  - Bulb lamps (if foreseen) used in this appliance are special purpose lamps selected for household appliances use only. They are not suitable for household room illumination.

## DAILY USE

- Do not put hot pot on the plastic parts in the appliance.
- Do not store flammable gas and liquid in the appliance, because they may explode.
- Do not place food products directly against the air outlet on the rear wall. (If the appliance is Frost Free)
- Frozen food must not be re-frozen once it has been thawed out.
- Store pre-packed frozen food in accordance with the frozen food manufacturer's instructions.
- Appliance's manufacturers storage recommendations should be strictly adhered to. Refer to relevant instructions.
- Do not place carbonated or fizzy drinks in the freezer compartment as it creates pressure on the container, which may cause it to explode, resulting in damage to the appliance.
- Ice lollies can cause frost burns if consumed straight from the appliance.

## CARE AND CLEANING

- Before maintenance, switch off the appliance and disconnect the mains plug from the mains socket.
- Do not clean the appliance with metal objects.

- Do not use sharp objects to remove frost from the appliance. Use a plastic scraper.
- Regularly examine the drain in the refrigerator for defrosted water. If necessary, clean the drain. If the drain is blocked, water will collect in the bottom of the appliance.
- Never use a hair drier or other heating appliances to speed up defrosting. Excessive heat may damage the plastic interior, and humidity could enter the electric system making it live.

## INSTALLATION



For electrical connection carefully follow the instructions given in specific paragraphs.

- Unpack the appliance and check if there are damages on it. Do not connect the appliance if it is damaged. Report possible damages immediately to the place you bought it. In that case retain packing.
- It is advisable to wait at least four hours before connecting the appliance to allow the oil to flow back in the compressor.
- Adequate air circulation should be around the appliance, lacking this leads to overheating. To achieve sufficient ventilation follow the instructions relevant to installation.
- Wherever possible the back of the product should be against a wall to avoid touching or catching warm parts (compressor, condenser) to prevent possible burn.
- The appliance must not be located close to radiators or cookers.
- Make sure that the mains plug is accessible after the installation of the appliance.
- Connect to potable water supply only (If a water connection is foreseen).

## SERVICE

- Any electrical work required to do the servicing of the appliance should be carried out by a qualified electrician or competent person.

- This product must be serviced by an authorized Service Centre, and only genuine spare parts must be used.

## ENVIRONMENT PROTECTION



This appliance does not contain gasses which could damage the ozone layer, in either its refrigerant circuit or insulation materials. The appliance shall not be discarded together with the urban refuse and rubbish. The insulation foam contains flammable gases: the appliance shall be disposed according to the applicable regulations to obtain from your local authorities. Avoid damaging the cooling unit, especially at the rear near the heat exchanger. The materials used on this appliance marked by the symbol  are recyclable.

# CONTROL PANEL

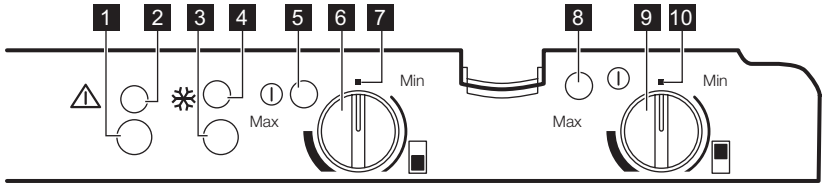

1. Alarm reset switch
2. Alarm light
3. Action Freeze switch
4. Action Freeze light
5. Freezer pilot light
6. Freezer temperature regulator
7. Freezer OFF position
8. Fridge pilot light
9. Fridge temperature regulator
10. Fridge OFF position

## SWITCHING ON

Insert the plug into the wall socket.  
Turn the Freezer temperature regulator clockwise to a medium setting.  
The Freezer pilot light will light up.  
Turn the Fridge temperature regulator clockwise to a medium setting.  
The Fridge pilot light will light up.



If the temperature inside the freezer is too high the Alarm light will light up and an alarm will sound.

## SWITCHING OFF

To turn off the appliance, turn the Freezer temperature regulator to the OFF position.  
The Freezer and Fridge pilot lights will switch off.

## SWITCHING OFF THE FRIDGE COMPARTMENT

To turn off the Fridge, turn the Fridge temperature regulator to the OFF position.  
The Fridge pilot light will switch off.



It is not possible to run only the fridge.  
If the freezer is turned off, the fridge will also turn off.

## TEMPERATURE REGULATION

The temperature is automatically regulated.  
To operate the appliance, proceed as follows:

- turn the Temperature regulator counter clockwise to obtain warmer storage temperature.
- turn the Temperature regulator clockwise to obtain colder storage temperature.



A medium setting is generally the most suitable.

The exact setting should be chosen keeping in mind that the temperature inside the appliance depends on:

- room temperature
- how often the door is opened
- the quantity of food stored
- the location of the appliance.



If the ambient temperature is high or the appliance is fully loaded, and the appliance is set to the lowest temperatures, it may run continuously causing frost to form on the rear wall. In this case the Temperature regulator must be set to a higher temperature to allow automatic defrosting and therefore reduced energy consumption.

## ACTION FREEZE FUNCTION

You can activate the Action Freeze function by pressing the Action Freeze button.  
The Action Freeze light will light up.



This function stops automatically after 52 hours.

It is possible to deactivate the function at any time by pressing the Action Freeze button. The Action Freeze light will switch off.

## TEMPERATURE ALARM

Temperature increase in the freezer compartment (for example due to an earlier power failure) is indicated by:

- Alarm light flashing.
- sounding of buzzer.

During the alarm phase, the buzzer can be switched off by pressing the Alarm reset button.

When normal conditions are restored the Alarm light will switch off automatically.

## DAILY USE

### FREEZING FRESH FOOD

The freezer compartment is suitable for freezing fresh food and storing frozen and deep-frozen food for a long time.

To freeze small amount of fresh foods it is not necessary to change the present setting.

To freeze fresh food activate the Action Freeze function 24 hours before placing the food to be frozen in the freezer compartment.

Place the fresh food to be frozen in the two top compartments.

The maximum amount of food that can be frozen in 24 hours is specified on the **rating plate**, a label located on the inside of the appliance.

The freezing process lasts 24 hours: during this period do not add other food to be frozen.

### STORAGE OF FROZEN FOOD

When first starting-up or after a period out of use, before putting the products in the compartment let the appliance run at least 2 hours.



In the event of accidental defrosting, for example due to a power failure, if the power has been off for longer than the value shown in the technical characteristics chart under "rising time", the defrosted food must be consumed quickly or cooked immediately and then re-frozen (after cooling).

### THAWING

Deep-frozen or frozen food, prior to being used, can be thawed in the refrigerator compartment or at room temperature, depending on the time available for this operation.

Small pieces may even be cooked still frozen, directly from the freezer: in this case, cooking will take longer.

### VEGETABLE DRAWER

The drawer is suitable for storing fruit and vegetables.

Some models have a separator inside the drawer that can be placed in different positions to allow for the subdivision best suited to personal needs.

All parts inside the drawer can be removed for cleaning purposes.

### FREEZING BASKETS

The freezer baskets ensure that it is quick and easy to find the food package you want. To gain space, the baskets can be removed and the food can be put directly on the shelves. On all shelves, except the top shelf, it is possible to place food that protrude 20 mm from the front edge. This allows maximum use of the available space.



Do not remove the bottom basket to ensure correct air circulation.

### MOVABLE SHELVES

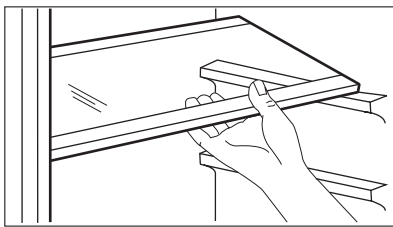

The walls of the refrigerator are equipped with a series of runners so that the shelves can be positioned as desired.

Some shelves must be lifted up by the rear edge to enable them to be removed.



Do not move the glass shelf above the vegetable drawer to ensure correct air circulation.



## REMOVAL OF FREEZING BASKETS FROM THE FREEZER

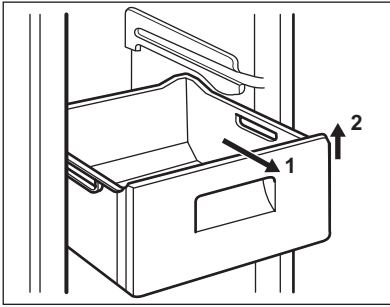

The freezing baskets have a limit stop to prevent their accidental removal or falling out. At the time of its removal from the freezer, pull the basket towards yourself and, upon reaching the end point, remove the basket by tilting its front upwards. At the time of putting it back, slightly lift the front of the basket to insert it into the freezer. Once you are over the end points, push the baskets back in their position.

## POSITIONING THE DOOR SHELVES

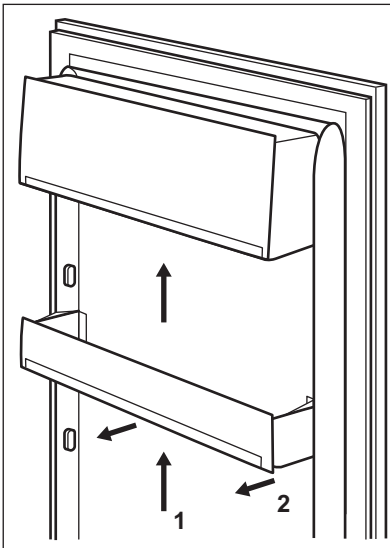

To permit storage of food packages of various sizes, the door shelves can be placed at different heights.

To make these adjustments proceed as follows:

gradually pull the shelf in the direction of the arrows until it comes free, then reposition as required.



Do not move the lower door shelf to ensure correct air circulation.

## CLEANING THE INTERIOR

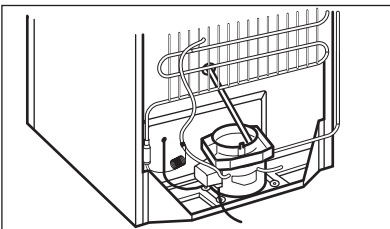

Before using the appliance for the first time, wash the interior and all internal accessories with lukewarm water and some neutral soap so as to remove the typical smell of a brand-new product, then dry thoroughly.



Do not use detergents or abrasive powders, as these will damage the finish.

Check that the drain hose at the rear of the cabinet discharges into the drip tray

## HELPFUL HINTS AND TIPS

### HINTS FOR ENERGY SAVING

- Do not open the door frequently or leave it open longer than absolutely necessary.
- If the ambient temperature is high and the Temperature Regulator is set to low temperature and the appliance is fully loaded, the compressor may run continuously, causing frost or ice on the evaporator. If this happens, set the Temperature Regulator toward warmer settings to allow automatic defrosting and so a saving in electricity consumption.

### HINTS FOR FRESH FOOD REFRIGERATION

To obtain the best performance:

- do not store warm food or evaporating liquids in the refrigerator
- do cover or wrap the food, particularly if it has a strong flavour
- position food so that air can circulate freely around it

### HINTS FOR REFRIGERATION

Useful hints:

Meat (all types) : wrap in polythene bags and place on the glass shelf above the vegetable drawer.

For safety, store in this way only one or two days at the most.

Cooked foods, cold dishes, etc...: these should be covered and may be placed on any shelf.

Fruit and vegetables: these should be thoroughly cleaned and placed in the special drawer(s) provided.

Butter and cheese: these should be placed in special airtight containers or wrapped in aluminium foil or polythene bags to exclude as much air as possible.

Milk bottles: these should have a cap and should be stored in the bottle rack on the door.

Bananas, potatoes, onions and garlic, if not packed, must not be kept in the refrigerator.

### HINTS FOR TEMPERATURE INSIDE THE FRIDGE

- A suitable temperature inside the fridge is approx. +5° C. It is normal with higher temperature in the top of the fridge and lower temperature in the lower part. If the temperature regulator is set to a cold temperature, the ambient temperature is high or if the fridge is fully loaded the compressor will run for a longer time. This results in colder temperature in the lower part of the fridge due to the cold air that falls down. It may result in that food with high water content start to freeze. If too cold, change to a higher temperature setting.



Do not place any shelves towards the water drain hole. This can result in too cold temperatures.

- If you want to check the temperature of food stored in the refrigerator, place a glass of water centrally in the cabinet, and put a proper thermometer with an accuracy of +/- 1 °C into it. After 6 hours the temperature can be monitored. The measuring shall be performed under steady-stated conditions (without changing the load).

### HINTS FOR FREEZING

To help you make the most of the freezing process, here are some important hints:

- the maximum quantity of food which can be frozen in 24 hrs. is shown on the rating plate;
- the freezing process takes 24 hours. No further food to be frozen should be added during this period;
- only freeze top quality, fresh and thoroughly cleaned, foodstuffs;
- prepare food in small portions to enable it to be rapidly and completely frozen and to make it possible subsequently to thaw only the quantity required;
- wrap up the food in aluminium foil or polythene and make sure that the packages are airtight;
- do not allow fresh, unfrozen food to touch food which is already frozen, thus

avoiding a rise in temperature of the latter;

- lean foods store better and longer than fatty ones; salt reduces the storage life of food;
- water ices, if consumed immediately after removal from the freezer compartment, can possibly cause the skin to be freeze burnt;
- it is advisable to show the freezing in date on each individual pack to enable you to keep tab of the storage time.

## HINTS FOR STORAGE OF FROZEN FOOD

To obtain the best performance from this appliance, you should:

- make sure that the commercially frozen foodstuffs were adequately stored by the retailer;
- be sure that frozen foodstuffs are transferred from the foodstore to the freezer in the shortest possible time;
- not open the door frequently or leave it open longer than absolutely necessary;
- once defrosted, food deteriorates rapidly and cannot be refrozen;
- do not exceed the storage period indicated by the food manufacturer.

## CARE AND CLEANING



### CAUTION!

Unplug the appliance before carrying out any maintenance operation.



This appliance contains hydrocarbons in its cooling unit; maintenance and recharging must therefore only be carried out by authorized technicians.

## PERIODIC CLEANING

The equipment has to be cleaned regularly:

- clean the inside and accessories with lukewarm water and some neutral soap.
- regularly check the door seals and wipe clean to ensure they are clean and free from debris.
- rinse and dry thoroughly.



Do not pull, move or damage any pipes and/or cables inside the cabinet.

Never use detergents, abrasive powders, highly perfumed cleaning products or wax polishes to clean the interior as this will damage the surface and leave a strong odor.

Clean the condenser (black grill) and the compressor at the back of the appliance with a brush. This operation will improve the performance of the appliance and save energy consumption.



Take care of not to damage the cooling system.



When moving the cabinet, lift it by the front edge to avoid scratching the floor.

Many proprietary kitchen surface cleaners contain chemicals that can attack/damage the plastics used in this appliance. For this reason use a soft cloth rinsed in warm water and neutral soap emulsion for cleaning external surfaces.



Do not use detergents or abrasive paste as these will damage the paint, or stainless steel anti finger print coating.

After cleaning, reconnect the equipment to the mains supply.

## CLEANING THE VENTILATION GRILLE

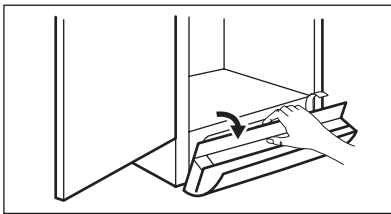

The ventilation grille can be removed for washing.

Make sure the door is open and then:

- Loosen the upper edge of the grille by pulling outward/downward.
- Pull the grille straight out to completely remove it.
- Vacuum clean under the cabinet.

## DEFROSTING THE REFRIGERATOR

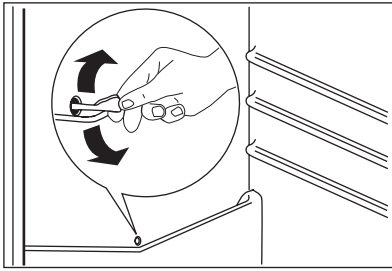

Frost is automatically eliminated from the evaporator of the refrigerator compartment every time the motor compressor stops, during normal use. The defrost water drains out through a drain hole into a special container at the back of the appliance, over the motor compressor, where it evaporates. It is important to periodically clean the defrost water drain hole in the middle of the refrigerator compartment channel to prevent the water overflowing and dripping on to the food inside.

## DEFROSTING THE FREEZER

A certain amount of frost will always form on the freezer shelves and around the top compartment.

Defrost the freezer when the frost layer reaches a thickness of about 3-5 mm.

To remove the frost, follow the instructions below:

- switch off the appliance and pull out the plug from the wall socket
- remove any stored food, wrap it in several layers of newspaper and put it in a cool place
- remove the freezer drawers
- put insulating material around the drawers, e.g. blankets or newspapers.

Defrosting can be accelerated by placing bowls with hot water (not boiling) inside the freezer.

- Loosen the drainage channel from its resting position, push it in according to the illustration and collect a water container.

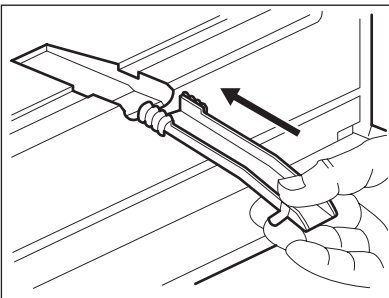

- carefully scrape off the ice when it starts to thaw. Use a wood or a plastic scraper

- when all the ice has melted, clean and wipe the cabinet dry, then put the drainage channel back in place.
- switch on the cabinet, insert the plug into the wall socket and replace the frozen foodstuff.



Never use sharp metal tools to scrape off frost from the evaporator as you could damage it. Do not use a mechanical device or any artificial means to speed up the thawing process other than those recommended by the manufacturer. A temperature rise of the frozen food packs, during defrosting, may shorten their safe storage life.

## PERIODS OF NON-OPERATION

When the appliance is not in use for long periods, take the following precautions:

1. disconnect the appliance from electricity supply
2. remove all food
3. defrost and clean the appliance and all accessories
4. leave the door/doors open to prevent unpleasant smells.



If the cabinet will be kept on, ask somebody to check it once in a while to prevent the food inside from spoiling in case of a power failure.

## WHAT TO DO IF...

During operation of the appliance some smaller but annoying trouble can often occur, which does not require calling a technician out. In the following chart information is given about them to avoid unnecessary charges on service.



The appliance operates discontinuously, so the stopping of compressor does not mean being no current. That is why you must not touch the electrical parts of the appliance before breaking the circuit.



The operation of the appliance goes with certain sounds (compressor and circulating sound). This not means a trouble, but a normal operation.

<b>Problem</b>	<b>Possible cause</b>	<b>Solution</b>
<b>The appliance is noisy.</b>	The appliance is not supported properly.	Check if the appliance stands stable (all feet and wheels should be on the floor). Refer to "Levelling".
<b>The buzzer sounds. The Alarm light flashing.</b>	The temperature in the freezer is too high.	Refer to "Temperature Alarm"
<b>Pilot light flashing.</b>	An error has occurred in measuring the temperature.	Call your service representative (the cooling system will continue to keep food products cold, but temperature adjustment will not be possible).
<b>The compressor runs continuously.</b>	The Temperature regulator may be set incorrectly.	Set a warmer temperature.
	The door is not closed correctly.	Refer to "Closing the door".
	The door has been opened too frequently.	Do not keep the door open longer than necessary.
	The food temperature is too high.	Let the food temperature decrease to room temperature before storage.
	The room temperature is too high.	Decrease the room temperature.
<b>Water flows on the rear plate of the refrigerator.</b>	During the automatic defrosting process, frost defrosts on the rear plate.	This is correct.
<b>Water flows inside the refrigerator.</b>	The water outlet is clogged.	Clean the water outlet.
	Food prevent that water flows into the water collector.	Make sure that food do not touch the rear plate.

<b>Problem</b>	<b>Possible cause</b>	<b>Solution</b>
<b>Water flows on the ground.</b>	The melting water outlet does not flow in the evaporative tray above the compressor.	Attach the melting water outlet to the evaporative tray.
<b>There is too much frost and ice.</b>	Food are not wrapped properly.	Wrap the food better.
	The door is not closed correctly.	Refer to "Closing the door".
	The door gasket is deformed or dirty.	Refer to "Closing the door".
	The Temperature regulator may be set incorrectly.	Set a warmer temperature.
<b>The temperature in the appliance is too cold</b>	The Temperature regulator may be set incorrectly.	Set a warmer temperature.
<b>The temperature in the appliance is too warm.</b>	The Temperature regulator may be set incorrectly.	Set a colder temperature.
	The door is not closed correctly.	Refer to "Closing the door".
	The food temperature is too high.	Let the food temperature decrease to room temperature before storage.
<b>The temperature in the refrigeration is too warm.</b>	There is no cold air circulation in the appliance.	Make sure that there is cold air circulation in the appliance.
	Large quantities of food to be cooled were put in at the same time.	Insert smaller quantities of food to be cooled at the same time.
<b>The temperature in the freezer is too warm.</b>	Food is too near to each other.	Store food so that there is cold air circulation.
	Large quantities of food to be frozen were put in at the same time.	Insert smaller quantities of food to be frozen at the same time.
<b>The appliance does not operate.</b>	The appliance is switched off.	Switch on the appliance.
	The mains plug is not connected to the mains socket correctly.	Connect the mains plug to the mains socket correctly.
	The appliance has no power. There is no voltage in the mains socket.	Connect another electrical appliance to the mains socket. Check fuse. Contact a qualified electrician.

<b>Problem</b>	<b>Possible cause</b>	<b>Solution</b>
<b>The lamp does not work.</b>	The lamp is defective.	Refer to "Replacing the lamp".
	The door has been open too long.	Close the door.
<b>Door interferes with ventilation grill.</b>	The appliance is not levelled.	Refer to "Levelling"
<b>Misaligned door</b>	The appliance is not levelled.	Refer to "Levelling"

As much as the advice does not lead to result, call the nearest brand-mark service.

## REPLACING THE LAMP

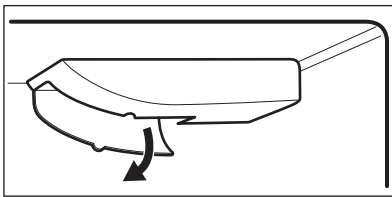

1. Disconnect the appliance from the power socket.
2. Fold the lamp cover backward by loosening the front edge.
3. Replace the bulb with one of the same power and specifically designed for household appliances (the maximum power is shown on the light diffuser) and with E14 socket type.
4. Reconnect the appliance.

## CLOSING THE DOOR

1. Clean the door gaskets.
2. If necessary, adjust the door. Refer to "Installation".
3. If necessary, replace the defective door gaskets. Contact the Service Center.



# INSTALLATION



## WARNING!

Read the "Safety Information" carefully for your safety and correct operation of the appliance before installing the appliance.

## POSITIONING

Install this appliance at a location where the ambient temperature corresponds to the climate class indicated on the rating plate of the appliance:

Cli- mate class	Ambient temperature
SN	+10°C to + 32°C
N	+16°C to + 32°C
ST	+16°C to + 38°C
T	+16°C to + 43°C

## LOCATION

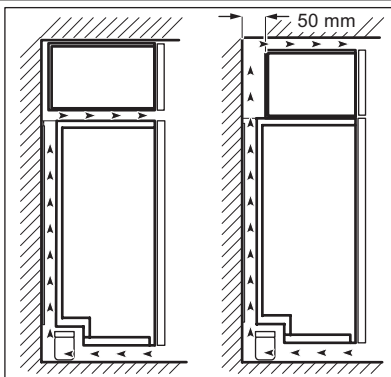

To ensure best performance, if the appliance is positioned below an overhanging wall unit, the minimum distance between the top of the cabinet and the wall unit must be at least 40 mm. Ideally, however, the appliance should not be positioned below overhanging wall units.

The ventilation space can be:

- directly above the appliance
- behind and above the top cupboard.

In this case, the space behind the top cupboard must be at least 50 mm deep.

## ELECTRICAL CONNECTION

Before plugging in, ensure that the voltage and frequency shown on the rating plate correspond to your domestic power supply.

The appliance must be earthed. The power supply cable plug is provided with a contact for this purpose. If the domestic power

supply socket is not earthed, connect the appliance to a separate earth in compliance with current regulations, consulting a qualified electrician.

The manufacturer declines all responsibility if the above safety precautions are not observed.

This appliance complies with the E.E.C. Directives.

## REMOVING THE TRANSPORT SUPPORT

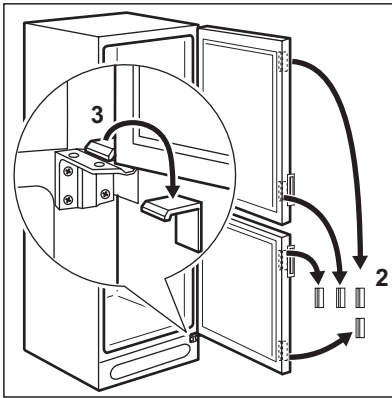

Your appliance is equipped with transport support to secure the door during transportation.

To remove them do these steps:

- Open the door.
- Remove the transport support from the door sides.
- Remove the transport support from the lower hinge (some models).



Some models are fitted with a silencing pad under the cabinet. Do not remove this pad.

## LEVELLING

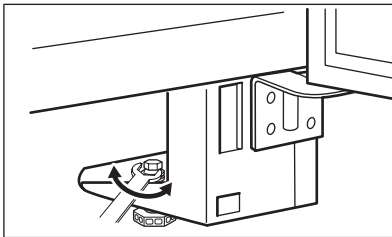

- When placing the appliance ensure that it stands level. If necessary adjust the feet using the adjustment spanner supplied.

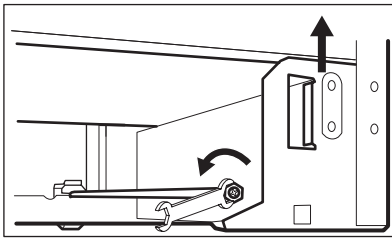

- On some models the wheels in the back-side can be adjusted by turning the nut on the threaded rod to the left to raise the appliance and to the right to lower the appliance.

## DOOR REVERSIBILITY

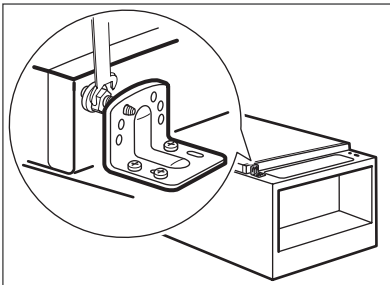
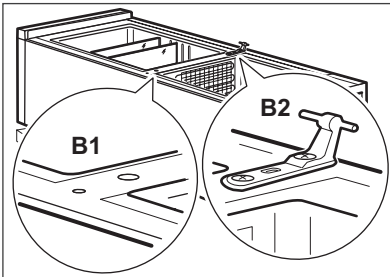
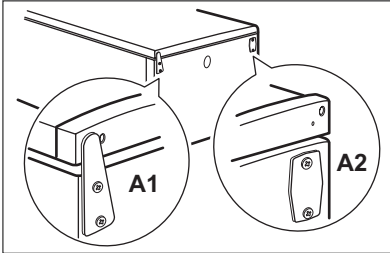
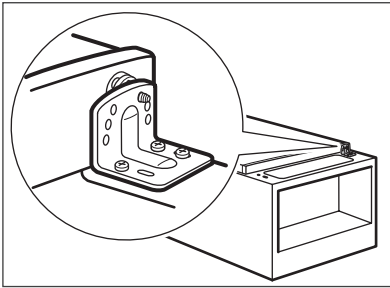

To change the opening direction of the door, do these steps:

- Remove the plug from the power socket.
- Remove the ventilation grille. Remove the filling and install it on the opposite side of the grille.
- Lay down the appliance back side down on a wooden support.
- Unscrew the lower hinge and remove the lower door.
- Unscrew the upper hinge (A1) and remove the upper door.
- Unscrew the cover washer (A2) and install it on the opposite side.
- Remove the hole covers (B1) by driving a drift into them and rocking them loose.
- Unscrew the middle hinge (B2) and install it on the opposite side.
- Install the hole covers provided within the accessory bag.
- Install the upper door and screw the upper hinge.
- Install the lower door and screw the lower hinge by changing the position of the pin.
- Tighten the pin. Make sure that the doors are aligned and blocked by the lock-nut

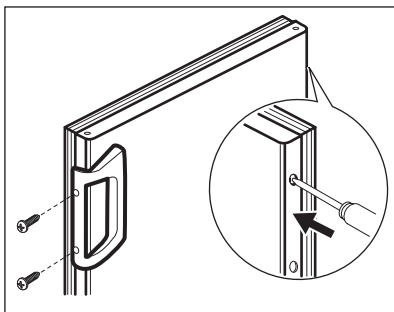

- Raise the appliance and install the ventilation grille.
- Unscrew the handle. On the opposite side remove the hole covers by driving a 3–4 mm drift or drill into them. Install the handle.
- Install the hole covers provided within the accessory bag.
- Put the cabinet in position.



**WARNING!**

Reposition, level the appliance, wait for at least four hours and then connect it to the power socket.

Do a final check to make sure that:

- All screws are tightened.
- The magnetic seal adheres to the cabinet.
- The door opens and closes correctly.



**WARNING!**

If the ambient temperature is cold (i.e. in Winter), the gasket may not fit perfectly to the cabinet. In that case, wait for the natural fitting of the gasket.

# NOISES

There are some sounds during normal running (compressor, refrigerant circulation).

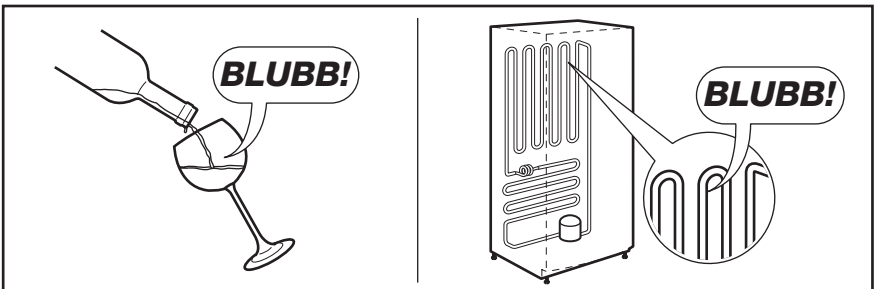
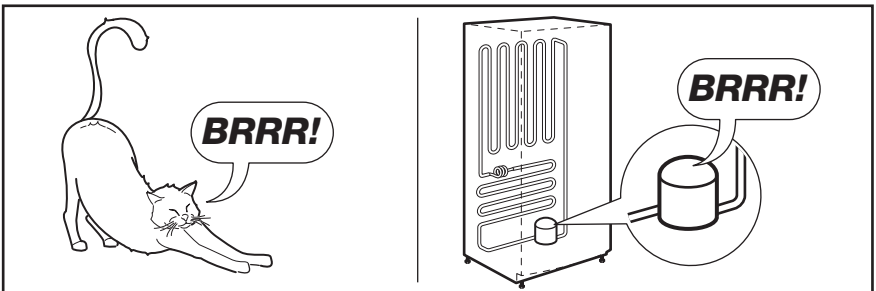
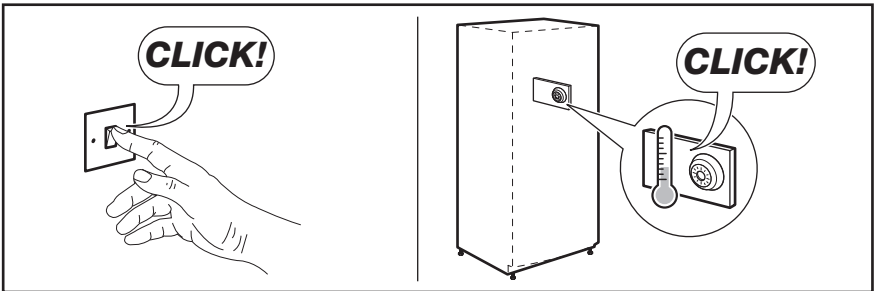
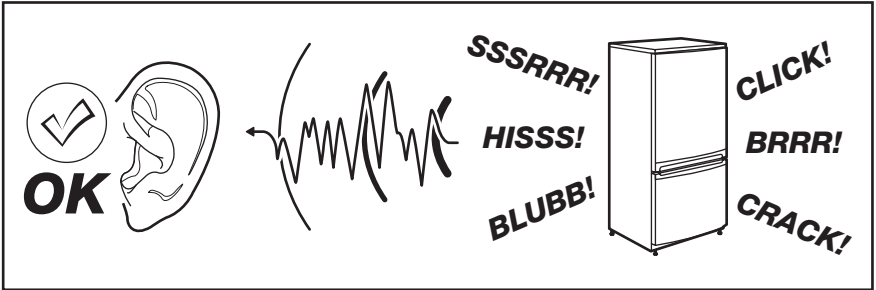

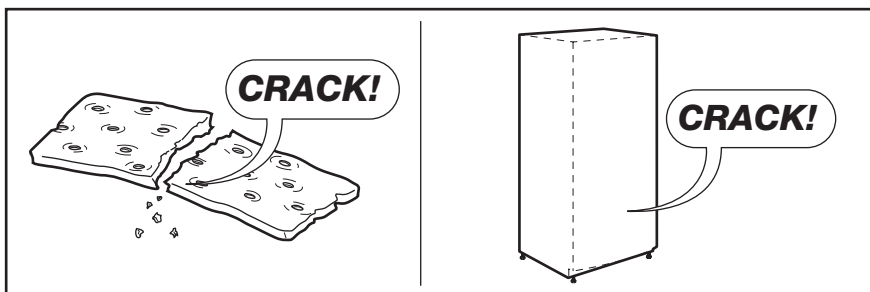
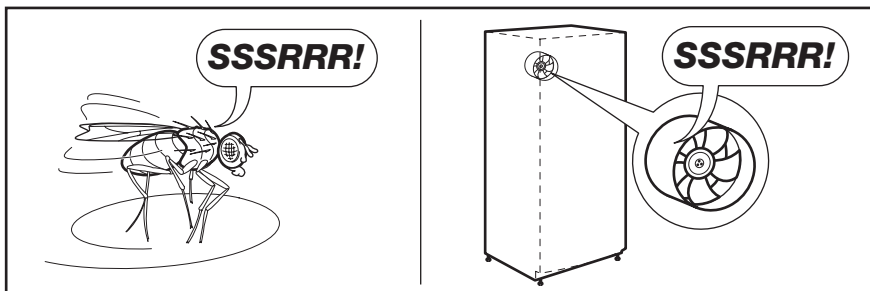



## TECHNICAL DATA

	<b>EN3700AHW</b>	<b>ERB34258W</b>
Dimension		
Height	1950 mm	1750 mm
Width	595 mm	595 mm
Depth	623 mm	623 mm
Rising Time	18 h	18 h
Voltage	230 V	230 V
Frequency	50 Hz	50 Hz

The technical information are situated in the rating plate on the internal left side of the appliance and in the energy label.

## ENVIRONMENT CONCERNS

Recycle the materials with the symbol  .  
Put the packaging in applicable containers  
to recycle it.  
Help protect the environment and human  
health and to recycle waste of electrical

and electronic appliances. Do not dispose  
appliances marked with the symbol  with  
the household waste. Return the product  
to your local recycling facility or contact  
your municipal office.

