

**7.1 Examples (cont.)**

Example with Speed control differential output stadio.

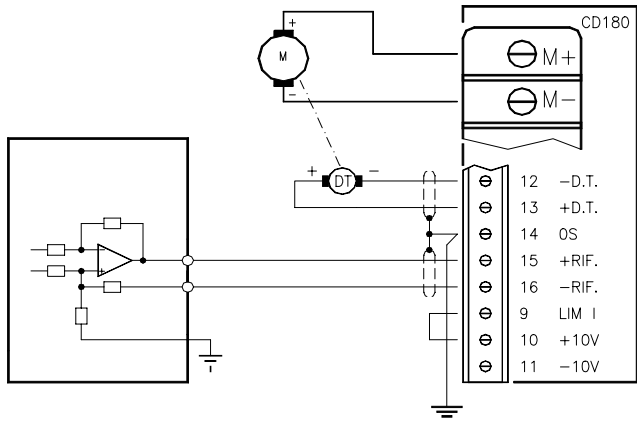

Example with speed control in common mode output stadio.

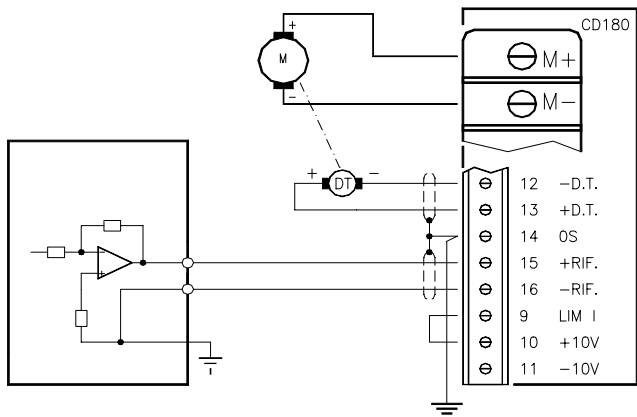

# CAUTION!

**ELECTRICAL AND CONTROL EQUIPMENT MAY BE DANGEROUS IF HANDLED IMPROPERELY**

This manual show mechanical and electrical characteristics about CD180 series.

It is important, that the installation procedure should be performed only by qualified personnel according with local safety rules. Who installs the equipment must follow the technical information contained in this manual.

For other informations please contact AXOR technicians.



**ATTENTION**  
ELECTRICAL DISCHARGE DANGER



## 7.1 examples (cont.)

Examples: reference connection from internal or external source.

NOTE: the greens on the reference cables and of the tachogenerator have to be connected to the terminal n.14 OS of the converter. Joint to be avoided. From the terminal n.14 you have to start with the mass connection.

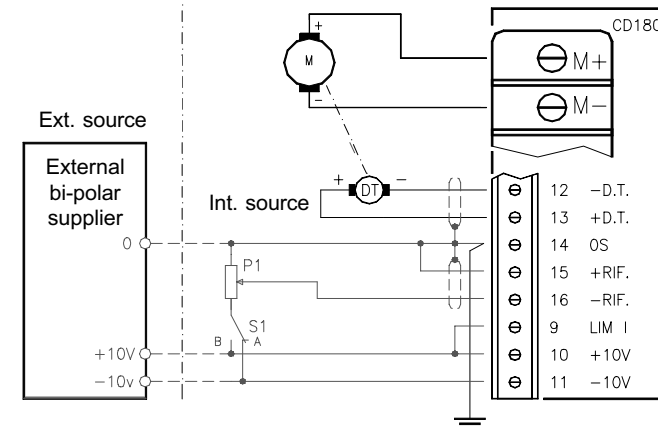
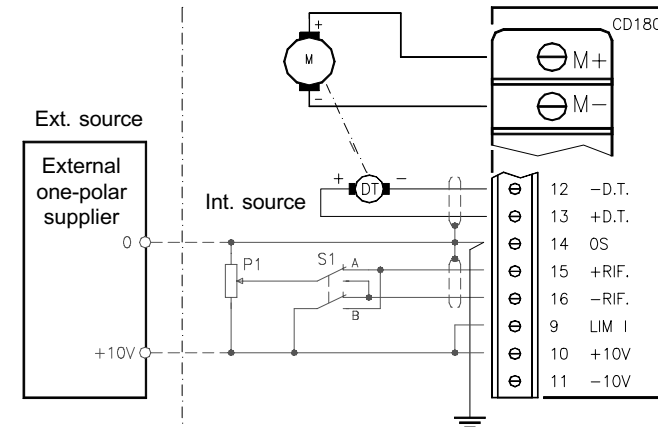

### 7.1 Examples (cont.)

**EXCLUSION LIMIT I EXT.**

With terminal n.9 and n.10 connected, the external limitation is excluded. With terminal n.9 free, limitation is totally inserted. I = 0A

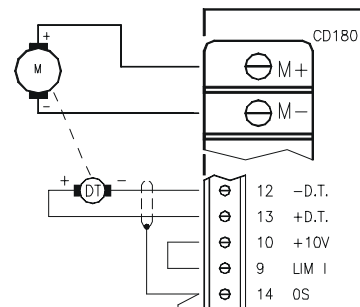

With :

S1 open = limit. I ext. inserted = 0A  
 S1 closed = limitation programmable with P1 from 0% to 100%.  
 P1 = 3Kohm min.

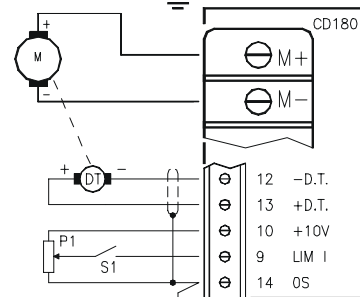

With:

S1 pos. A = lim. I ext. excluded (I=100%)  
 S1 pos. B = lim. I ext. inserted. The I can be programmed according to the formula:

$$R1(\text{Kohm}) = \frac{(3.3 \times I_{\text{max}}) - 3.3}{I_{\text{richiesta}}}$$

where  $I_{\text{max}} = I_{\text{max CD}}$

R2 = 3.3Kohm

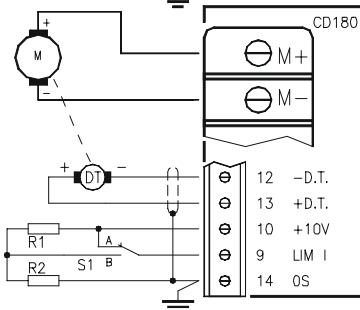

## Index

### 1) Descriptions

- 1.1 Introduction ..... pag. 4
- 1.2 Technical informations..... pag. 5
- 1.3 Applications..... pag. 5
- 1.4 Dimensions..... pag. 6
- 1.5 Functional diagram..... pag. 7
- 1.6 Connection diagram..... pag. 7

### 2) Connectors

- 2.1 Signal connector..... pag. 8

### 3) Signalling and calibrations

- 3.1 Personal card..... pag. 10
- 3.2 Signal led..... pag. 12
- 3.3 TP diagnostic connector..... pag. 13

### 4) Installation

- 4.1 Power wiring..... pag. 15
- 4.2 Signal wiring (4.2a 4.2b ecc.)..... pag. 15
- 4.3 External components dimensionality..... pag. 16

### 5) Starting procedure

- 5.1 Preliminary controls..... pag. 18
- 5.2 Starting procedure..... pag. 19
- 5.3 Calibrations..... pag. 20
- 5.4 Options..... pag. 22

### 6) Faults

- 6.1 Faults research..... pag. 24

### 7) Special functions

- 7.1 Examples..... pag. 25

## 1.1 Introduction

### Transistor switching converters to control DC permanent magnet motors.

Thanks to the easiness of installations, the semplicity of operations and the considerable varied range of performances available, our articles perfectly come up to the current request of the market. Because of the autogeneration of the internal auxiliary voltages, a three phase transformer, with only one secondary, is necessary for their supply.

The 5 KHz frequency modulation allow the elimination, nearly in all motors, of the inductance series of the additional levelling. As all the equipments are internally self ventilated, an exterior blower cooling (and the consequent additions of rack) is not needed. Rated current is guaranteed up to a room temperature of 40°C for all the sizes.

Braking unit to carry of the energy of the motor during the recovery phase, ar internally set. Inputs and outputs, either of power or signal, are completely available on the frontal. All the above characteristics enable these moduls to suit also the multiaxis executions.

To guaranteed the max. security of the external operator and the freedom of connection, the power stage is separated from the control circuits in a galvanic way. The converter is self-protected against autput short-circuits between the terminal motor. In case of anomaly, the operations of the equipment is stopped by an internal diagnostic circuit.

It intervention is memorized and externally reported by a green led. When the position of the led is in ON, the converter is all right. To restore the allarm it is necessary to take away and return the voltage to the set.

The protection of the motor is provided with the limitation of effective current. When the max. cycle of loading exceeds, an internal limits takes effects; this is externally signalled by a red led. When the position of the led is ON , the limithas not intervened.

To protect motor at high revolutions, the max. current limitation function depending on the speed, is available.

All the external calibrations are available on the frontal and set on a removable card.

This makes our equipments perfectly interchangeable on the same size.

## 7.1 Examples

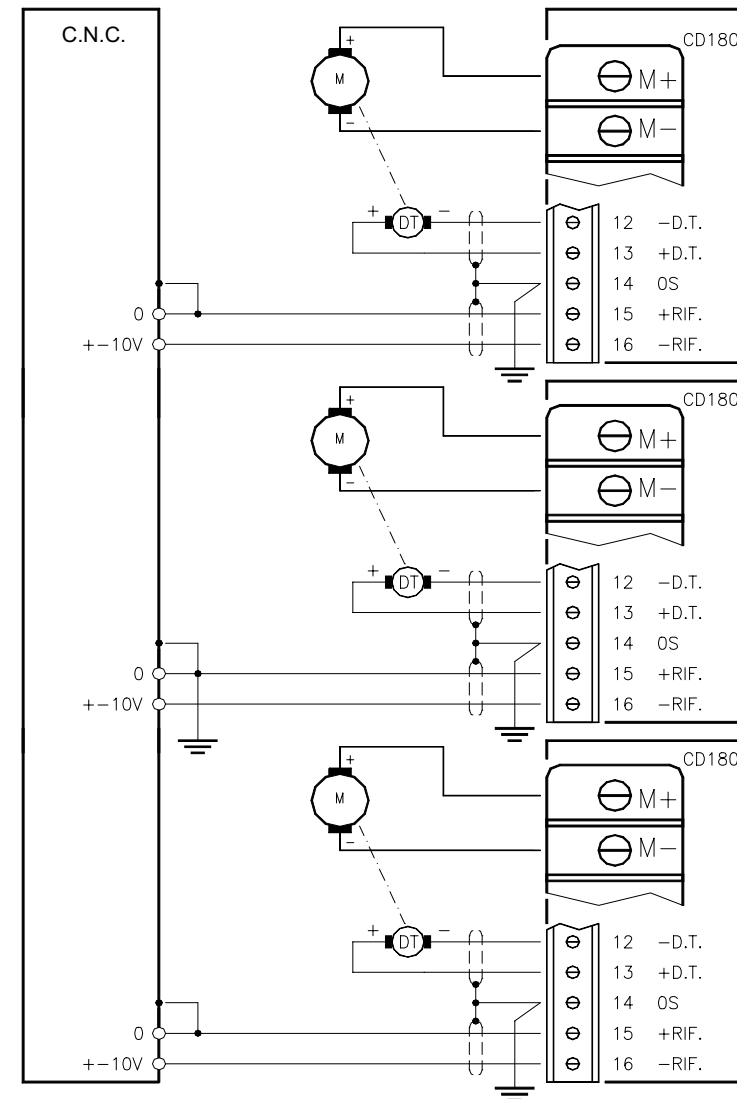

Es. : reference connection from external multiaxis CNC source

## 6.1 Faults research

1) After giving predisposition and with the converter supplied, the motor accelerates uncontrollably:

in this case it is possible that the connection between tachogenerator and plate motor is inverted or even lacking or broken. In presence of M.d.t. (tacho lacking), the motor starts its acceleration but after some turns the frontal L1 led turns off (CONV.OK) and the motor stops in a time depending on its mechanic inertia. At this point it is convenient to check the tachogenerator connection.

2) Given voltage, the MAX.REC., or max voltage, opens:

check using a tester, the output voltage of the supply transformer, which is probably too high.

3) In braking or motor deceleration phase, the MAX.REC. contact turns on:

Probably a too high PD<sup>2</sup> has been given to the driving shaft.

4) In acceleration motor phase the green led L1 (CONV.OK) turn off and the motor stops for inertia: the supply transformer power is not enough or its voltage short-circuit is too high.

5) In operating cycle the red led L2 (I<sup>2</sup>t) turns on and the motor loses torque:

the operating cycle is too hard and the motor is working more than its rated-torque characteristic.

6) With supplied working switched on predisposition and OK led lighted, the motor does not turn: check the terminal n.9 relative to the external current limit. If the voltage compared to the terminal n.14 is 0 volt the current in the motor is 0A. Connect suitably this terminal.

**For an easy search of the alarm causes, use the proper SINOPTYC card, and the relative booklet given under request.**

The characteristics can be modified without notice.

## 1.2 Technical informations

MODEL	RATED CURRENT	PEAK CURRENT	MAX. OUTPUT VOLTAGE
CD180 8/16	8A	16A	+/-200V
CD180 15/30	15A	30A	+/-200V
CD180 25/50	25A	50A	+/-200V
CD180 30/75	30A	75A	+/-200V
CD180 50/100	50A	100A	+/-200V
CD180 50/150	50A	150A	+/-200V

### Characteristics

- \* Frequency of 5KHz switching
- \* Working frequency at current loop = 1 KHz
- \* Room temperature allowed = 0 ÷ +40C°
- \* Tolerance on the power supply voltage = ± 10%
- \* Differential analogic reference input = ± 10V
- \* Input impedance = 24 KOhm
- \* Logical input signal of opto-isolated enable inputs
- \* Output signal available in clean contacts
- \* Peak current available for 5" until intervention I<sup>2</sup>t

### Dinamic protections

- \* Short - circuit motor (memorized)
- \* Max recovery cycle with release of power remote - control switch
- \* Min-Max supply voltage ( memorized)
- \* Max internal temperature (memorized)
- \* Internal anomaly diagnostic (memorized)
- \* Broken or inverted tachometer protection available (memorized)
- \* Dinamic braking againsts blackout conditions available
- \* I<sup>2</sup> x t function for thermic motor protection
- \* I<sub>max</sub> limitation at high speed function

## 1.3 Applications

- \* Axis translations for tool machines
- \* Machines to copy
- \* Various system of movements
- \* Industrial robot
- \* Positionings
- \* Transfer lines
- \* General need of very linear and accurate regulations

# 1.4 Dimension

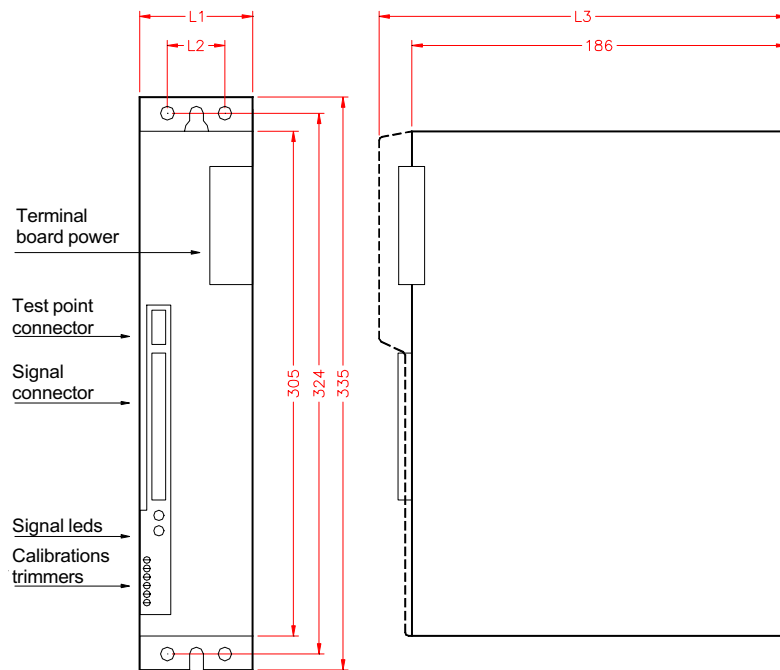

MODEL	L1	L2	L3
CD180 8/16 - 12/24	66	33	203
CD180 15/30 - 25/50 - 30/75	99	65	204
CD180 50/100 - 50/150	132	97	210

Dimensions are in mm.

# 5.4 Options (cont.)

## R.m.v. RELAY OUTPUTS OF MIN. SPEED

The signal of operating motor is indicated by a NO contact having its common on the terminal n.4 and the output on the terminal n.2 of the signal connector. For the regulation of the intervention threshold, see par. 3.1.2.

## POLARITY OF CONNECTIONS

To prederminate the right use of the motor rotation go on as follow:

- 1) The driving shaft has to be clockwise rotated by hand. It must be electrically unlinked to the converter. Using a texter, point out positive and negative polarity of the plate.
- 2) On the same conditions (as above) keep on rotating the driving shaft, again by hand, and point out the polarity of the tachogenerator.
- 3) Link the positive of the motor plate to the terminal +M of the converter and the negative to the terminal -M.

Link the positive of the tachogenerator to the terminal n.13 (+DT) and the negative to the terminal n.12 (-DT) of signal connector.

Putting on a positive reference on the terminal n.16 (-RIF) in comparision with the terminal n.15, the motor will rotate in a clockwise way. If the plate motor is wrongly connected to the tachigenerator, the motor can go in "escape" it means it is working uncontrollable, at the max speed and in a too short time. That is why, to avoid mechanics damages, it is recommended to operate with the driving shaft stopped.

## REFERENCE COMMON MODE

When a signal in differential mode is not used for the reference it is necessary to connect the terminal n.15 (+RIF) to the "0S", terminal n.14.

## BLOWER COOLING CONVERTERS

All the converters, if necessary, are already internally ventilated. No external set is needed. But in case of more set placed over, the min. distance between the converters has to be at least 15cm.

## ENVIROMENTAL CONDITIONS

For all the sizes, the rated current is guaranteed up to a room temperature of 40°C. In any case it is recommended not to exceed an operating room temperature of 60°C. In case of dusty places, it is necessary to keep the equipments inside electrical limits suitably filtered.

## 5.4 Option

### TEST POINT

The TP connector on the frontal of the set, provides a series of logical signal to be texted by a special synoptic alarm detector. It is available under request.

### TPOLOGY CONNECTION

To avoid anomalies on operation, it is recommended to follow these proceedings.

### POWER CONNECTIONS

the connection between the transformer and the drive must be carry out with suitable section cables. This is valid also for the motor connection. Medium currents must be considered in the calculation.

In addition a fast fuse tern in series at the secondary of the transformer for every converter must be provided. As for the dimensionality, see the relative table.

### SIGNAL CONNECTIONS

The tachogenerator and signal reference connections must be screened, the shields have to be linked to the terminal n.14, "0S".

At this point, it is possible to effectuate the grounding, as for the connection diagram.

### PREDISPOSITIONS

The release of modulation (PWM.ON), of reference (REF.ON), and of ramps (RAMPS.ON), must be short-circuited with the "0P" (terminal n.8), to obtain the predisposition.

### OUTPUT SIGNAL

The output signals from the converter are NO relay contacts. More exactly the common of the contacts is the terminal n.4 of the signal connector and the other contact head is the terminal n.1 for the MAX.REC. and the n.3 for the signalling of any anomaly, CONV.OK.

With a set in good working condition, these contacts close after 2" from the supply and reopen only in case of anomaly.

NOTE. The MAX.REC. contact has to adjust directly to power supply remote-control switch, as for connection diagram. If not, serious damage to the set can occure because of excessive tolerance on the max. voltage of the supply.

## 1.5 Functional diagram

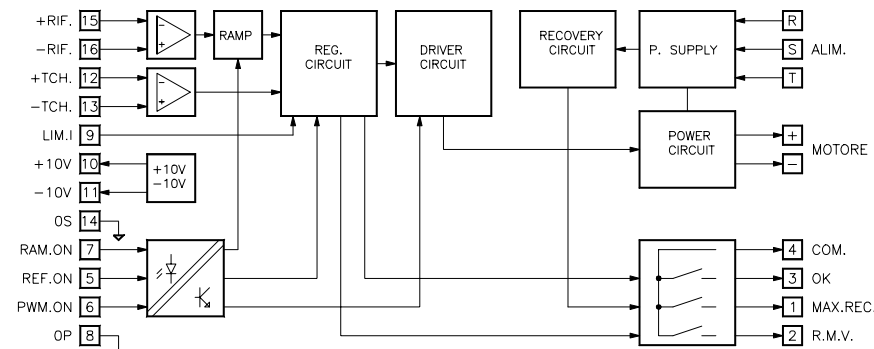

## 1.6 Connection diagram

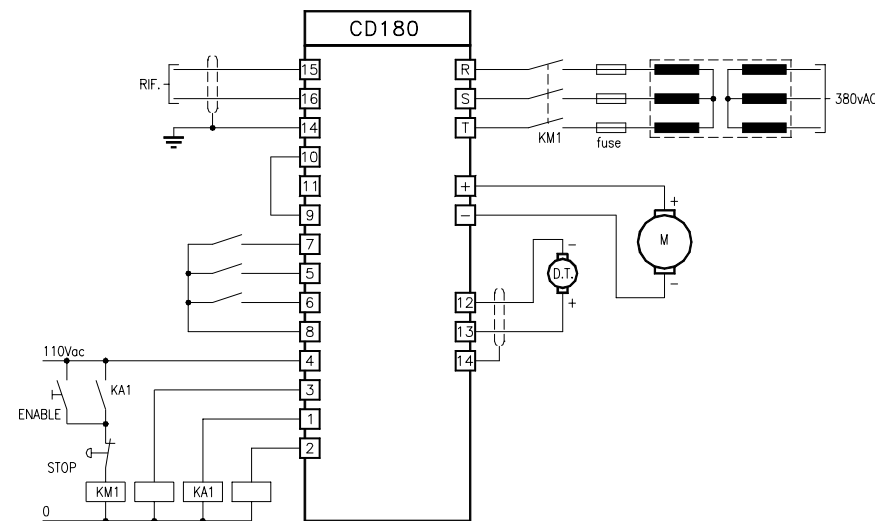

See also pages 15 and 16.

## 2.1 Signal connector

DENOMINATION	TERMINAL N°	DESCRIPTION
MAX REC.	1	<p><b>Output:</b> internal relay contact relative to the max dynamic braking cycle alarm. It can carry out a max voltage <math>V_{ac} = 110/115V</math>, or <math>V_{dc} = 48V</math> with a max current of 800mA. With supplied converter</p> <p><u>Contact in ON = OK</u> <u>Contact in OFF = intervention protection</u></p>
R.m.v.	2	<p><b>Output:</b> internal relay contact relative to the min. adjustable speed detector same loading as for MAX REC.</p> <p><u>Contact in ON = speed &gt; min. speed</u> <u>Contact in OFF = speed &lt; min. speed</u></p>
OK	3	<p><b>Output:</b> internal relay contact relative to the intervention of any alarm but MAX REC, it is memorized. It is restored by taking away and returning the voltage. Same loading as for MAX REC and R.m.v.</p> <p><u>Contact in on ON = protection OK</u> <u>Contact in OFF = protection intervened</u></p>
COMUNE	4	<p><b>Output:</b> common of the contacts relative to the terminal 1, 2 and 3.</p>
RIF.ON	5	<p><b>Input:</b> predisposition to signal of reference electrically separated by opto insulator. To be obtained bring this terminal to "0P".</p>
PWM.ON	6	<p><b>Input:</b> predisposition to modulation, electrically separated by opto insulator. To be obtained, bring the terminal to "0P".</p>

## 5.3 Calibrations (cont.)

- 7) ACC/DEC RAMP CALIBRATION  
 If request, the ACC/DEC ramp circuit is available. Incline variations are possible adjusting the T8 trimmer available on personal card. Clockwise rotation produces a decrease of the ramp time (from 1" to a min. value of 0.1").  
 The max. ramp time of 1" can be extended by introducing a C1 capacitor on the personal card. Under request it is also available a switching on/off function ramp stage provided with a logical signal on the outside terminal n.7 of the signal connector.  
 These optional function, if wanted, have to be request at the moment of the order.
- 8) BALANCING CALIBRATION  
 To make up for eventual external off-sets on the reference signal (which causes a light rotation of the motor), operate on the T6-BAL trimmer to stop the rotation of the motor. The operation has to be carried out with reference signal = 0V.
- 9) LIMIT CALIBRATION OF EXTERNAL TORQUES  
 It is possible to limit the current and as consequence the available torque at the driving shaft, bringing the terminal n.9 of the signal connector from +10V to 0V, as reported in the connection diagram. With +10V, 100% of the current torque is obtained, with 0V, the result is 0%.  
 If this function is not request, it has to be excluded by bringing to 10V fixed the terminal n.9, or closing the interior welding point n.S7.  
 If interested, this function must be requested at the moment of the order.
- 10) EMERGENCY BRAKING  
 If requested it is possible to obtain the fast dynamic braking against blackout conditions function which unables the interruption of the motor in case of blackout. To obtain this function it is necessary to stop the PWM.ON predisposition relative to the terminal n.6 of the signal connector, when the motor supply stops. In this way, the motor is controlled in fast braking until the min. speed threshold set.
- 11) ALARM RESTORATION  
 To restore the alarm that has been used it is necessary to take away and return voltage to the converter. Before returning voltage it is necessary to wait 10", if not the used alarm keep on signalling even if the cause for its action is not present any longer.



## 5.3 Calibrations

- 1) **RATED CURRENT CALIBRATION**  $I_n$   
It is obtained by inserting on the personal card a resistance called  $R_x$ , whose value is given by the following formula:

$$R_x \text{ in KOHM} = 2874 \times \frac{I_{\text{nom.}}^2}{I_{\text{max}}^2}$$

The max. time peak of the current depend on the ratio  $I_{\text{max}}/I_n$ . In any case it decrease according to the loss of  $I_n$  set in.

- 2) **MAX. CURRENT CALIBRATION**  $I_{\text{max}}$  IN FUNCTION OF THE SPEED  
Action is taken on the T1-R.P. and T2 R.S. trimmers to restrict the max current of peak motor turn function. In this case, the limits imposed by the switching bend of the motor itself, are not surpassed.  
**For the right calibration, it is recommended to ask for aou technical office.**
- 3) **RATED SPEED CALIBRATION**  
The rated speed arrangement is roughly calculated by the DIP SWITCH on personal card (see speed range table), and precisely calculated adjusting the multiturns trimmer on the T5-SPEED frontal. In absence of particular specifications, converters are produced calibrated for a 10V reference at the rated motor speed.
- 4) **THRESHOLD CALIBRATION** R.m.v. MIN SPEED RELAY  
R.m.v. circuit offers a clean NO contact available between the terminals n.4-COMMON and n.2-R.m.v of the signal connector. This contact closes then the tachogenerator exceed the level set up by the T7-R.m.v. trimmer on the personal card. Regulation fields included between the 0% and the 10% of the max. speed.
- 5) **CALIBRATION K.V. DYNAMIC PROFIT SPEED STAGE**  
It is obtained checking the T3-K.V. trimmer on frontal. Clockwise rotation increases the system answer.
- 6) **DERIVATE TACHOGENERATOR CALIBRATION**  
The T4-DER trimmer on the frontal introduces a lead regulation on the tachogenerator signal toward the collation knot with the reference signal. Clockwise rotation increases the derivative effect.

DENOMINATION	TERMINAL N°	DESCRIPTION
RAMPE ON	7	<b>Input:</b> predisposition to acceleration and deceleration ramps, electrically deparated by opto insulator. To be obtain bring the terminal ti "0P". <u>With RAMPE ON = L = on</u> <u>With RAMPE ON = H = off</u>
OP	8	<b>Output:</b> zero for predisposition.
LIM.I.EST.	9	<b>Input:</b> Current programming from outside by a voltage from 0 to +10Vdc, equivalent to a limitation from 100% to 0%.
+ 10V	10	<b>Output:</b> voltage available on the outside. $I_{\text{max}} = 8\text{mA}$ .
- 10V	11	<b>Output:</b> voltage available on the outside. $I_{\text{max}} = 8\text{mA}$ .
- D.T.	12	<b>Input:</b> tachogenerator.
+ D.T.	13	<b>Input:</b> tachogenerator.
OS	14	<b>Output:</b> zero signal for the connections of screws and c.n.c..
+ RIF.	15	<b>Input:</b> Not-reversing input, differential reference.
- RIF.	16	<b>Input:</b> reversing input, differential

**N.B.**

To take use of terminal 7 and 9, some internal weld point have to be executed by qualified personal. If the EXT.LIM.I is not used, it is necessary to connect the terminal 9 to +10V.

### 3.1 Personal card

All the external calibrations are available on the frontal and set on the removable card.

**ATTENTION:**  
Calibration for qualified personel

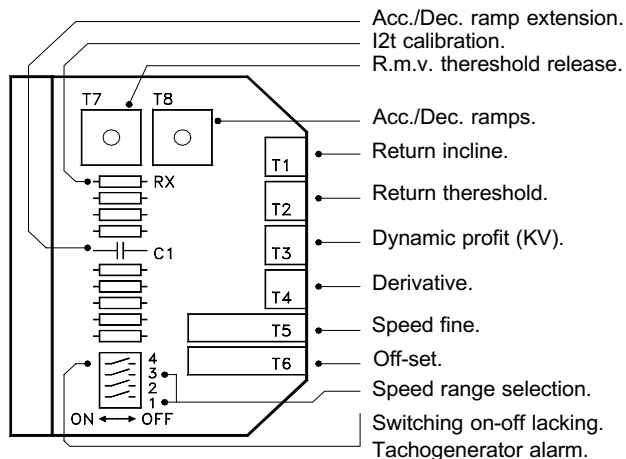

#### 3.1.1 Dip switch

N° 4 Switching on/off alarm for lacking or inverted tachogenerator.

N° 1,2,3 Speed range selection in binary system. The regulation fine inside each range is achieved by T5.

SPEED RANGE TABLE (Tachogenerator voltage)				
1	2	3	V.MIN	V.MAX
OFF	OFF	OFF	4V	24V
OFF	OFF	ON	15V	35V
OFF	ON	OFF	25V	44V
OFF	ON	ON	37V	56V
ON	OFF	OFF	46V	65V
ON	OFF	ON	58V	78V
ON	ON	OFF	68V	87V
ON	ON	ON	79V	99V

### 5.2 Starting procedures

- Keep the motor shaft free from load and be ready to switch off main power if necessary.
- Take out signal connector (from 1 to 16 marked) leaving connected wired to flying female connector.
- Put in series fuses on alternate feeding.
- Switch on the driver. After 1 second about, on normal operation mode green led on will light on. Motor must be stopped. If mentioned led don't light, please verify with a tester the choosen alternate feeding value. Switch off the three phases feeding.
- Insert signal connector and be sure that reference input is 0V.  
ATTENTION: when CNC driver the motor please use manual mode and not activated the error connector of CNC.
- Switch on the three phases power and after abilitate the regulation: PWM on activated. (Is good rule normally to give abilitation OK after the main power switch on of converter).

If motor stay on torque or it turn slittly, tachi polarity is correct. If tacho is inverted, after a low rotation, MD protection is activated "tacho loss or inverter tacho", disabling the converter.

Switch off the amplifier, exchange tacho wires and start again. ATTENTION: a minimum amount of times ha to be taken between a stop and start again in order to be sure of a real switch off of driver.

- Increase speed value signal to a minimum value of 1 Volt, and look to motor rotation direction. If motor turns wrong direction both polarity of tacho and motor must be inverted.

- Now activate space loop of CNC, if one. If now we have the same working way as before closing lop of CNC, and CNC don't gives "following position error", the driver is correctly regulated.

- Now please make standard working cycles verifying that no protections will go on.

## 5.1 Preliminari controls

The standard amplifier is provided as follow:

- Nominal and peak current agree with amplifier's size.
- Tachogenerator feedback.



Verify all screw clamp connections (power and signal) and control the proper wiring on the amplifier.  
 For motor and tacho polarity we will obtain clockwise direction with positive speed reference.  
 Motor and tachogenerator polarity are those declared from factory.

Now, we have 2 cases for CD180 starting procedure:

- 1) If the converter is adjusted for its motor, go on chapter "**Starting procedures**",
- 2) If the converter isn't adjusted consult chapter "**Calibrations**" and go on.

### 3.1.2 Calibration trimmer

DENOMINATION	TRIMMER N°	DESCRIPTION
R.P.	T1	Regulation of the incline intervention of the limitation current circuit of peak, in speed function. Anti-clockwise rotation increases the incline.
R.S.	T2	Regulation of the intervention threshold of the current limitation circuit of peak in speed function. Clockwise rotation reduces the intervention threshold. Anti-clockwise rotation leaves out the return function. This function unables to respect max. torque characteristic at high speed combinations of the permanent magnet motors.
K.V.	T3	Regulation of the dynamic profits or system promptness. Clockwise rotation increases the profits or the answer.
DERIVATIVE	T4	Lead regulation on the tachigenerator signal. Clockwise rotation increases the derivative effect.
FINE SPEED	T5	Fine motor speed regulation on the inside of the selected ranges by a dip-switch. Clockwise rotation reduces the speed.
OFF-SET	T6	Regulation of the zero setting speed in case of reference absence.

### 3.1.2 Calibrations trimmer (cont.)

DENIMONATION	TRIMMER N°	DESCRIPTION
R.m.v.	T7	Regulation of the min. speed relay release threshold. Clockwise rotation increases the thesold
ACC/DEC	T8	Unique regulation for the ACC. DEC. ramp. Clockwise rotation reduces the time of the ramp.

## 3.2 Signal led

DENOMINATION	LED	DESCRIPTION
OK	L1	<b>Green:</b> Signal of the intervention of any alarm except for the MAX. REC., it indicates the opening of the OK contact (terminal 3). It is memorized and to be restored it is necessary to take away and return voltage.  <u>With L1 = OFF = allarm</u> <u>With L1 = ON = converter OK</u>
I <sup>2</sup> t	L2	<b>Red:</b> Signal relative to the intervention of the effective motor current limitation. When operating, the peak current is not available. Its restoration comes at inverse time after the absorption has decrease below the rated current. <u>With L2 = OFF = OK</u> <u>With L2 = ON = signal released</u>

**N.B.** The use of test point or diagnostic connector enables the discrimination of the exactly cause of a L1 alarm signal.

### PROTECTIVE FUSES

#### Fuses for the primary

Normal fuses calculated according to the rated power of the transformer in KVA

$$F1 = \frac{Pa (VA)}{V_{primary} (\text{sqrt}3)^*} \quad (A)$$

\*sqrt3 = square root of 3

#### Fuse for the secondary

Fast fuses calculated and set up for every single converter to be used as following:

F2 =	CD180 8/16	12A fast
	CD180 15/30	16A fast
	CD180 25/50	25A fast
	CD180 30/75	35A fast
	CD180 50/100	50A fast
	CD180 50/150	80A fast

### EXTERIOR INDUCTANCE SERIES

if you want to drive motors with very low plated inductance (below 0.7 - 0.8mH) an exterior inductance to be linked in series if necessary.

In this way an improvement of the current form factor is obtained as the overheating of the motor is avoid.

The inductance values have been normalised depending on the converter size, as indicated in the table.

CD180 8/16	LX1
CD180 15/30	LX1
CD180 25/50	LX2
CD180 30/75	LX3
CD180 50/100	LX4
CD180 50/150	LX5

### 4.3 External components dimensionality

Proceeded to be followed:

- A) Choise and dimension of the transformer
- B) Dimension of fuses
- C) Choise inductance series to the motor (only where necessary)

#### SUPPLY TRANSFORMER

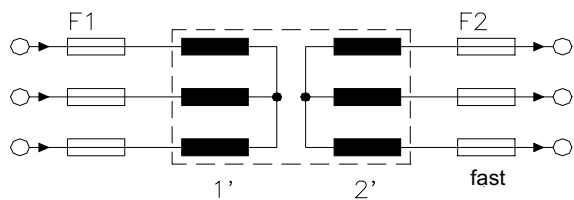

#### - Voltage

Primary voltage is linked to the line voltage available. The secondary voltage is calculated considering the characteristical datas of the motor you wont to drive. In any case it is very important included between a min. value of 110Vac (± 10% of line) and a max. value of 170Vac (± 10% of line) with empty transformer. The formula to obtain secondary voltage loading value is the following:

$$V_{ac} = (V_{mot} \times 0,9) \times 1,1$$

where  $V_{mot} = FCEM$  (with motor at the rated speed) +  $R_i$  (plate motor resistance with brushes) x  $I_n$  (rated motor current relative to the rated torque). In this formula we have supposed we can drive the motor also with -10% of line. To avoid driving motor problems in presence of high speeds and with max. loading, it is recommended not to exceed the 5%.

#### - Power

The rated power of the transformer is calculated according to the  $V_{mot}$  and the  $I_n$  of the motor (see previous notes). The formula is the following.

$$P = V_{mot} \times I_n$$

where  $P$  = power in KW obtained at the secondary. In the presence of a multiaxis system, the power of the transformer is given by the sum of all single powers. In fact the real constructuin power of the transformer can be lower than the theoretic one calculated as indicated above. In a tool machine where there are not very hard work cycles and with the axis not working at the same time and at the max. loading, the power can be reduced of 30/40%. The triangle secondary is recommended.

### 3.3 TP diagnostic connector

It is set on the frontal of equipment.

All test points are relative to logical levels, uncoupled by resistance in series at the outputs. 1,2 - 3,4 - 5,6 T.P. relative to +15V, -15V, 0P are excluded.



**ATTENTION:**  
The use of the diagnostic connector is reserved to qualified personal. In any case for a quick test, the use (via flat cable) of the relative "problem guide" is recommend.

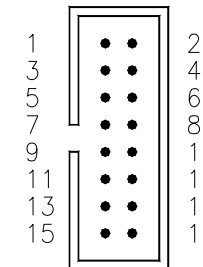

POSITION	SIGNAL	DESCRIPTION
1,2	-15V	Internal voltage supply -15V
3,4	+15V	Internal voltage supply +15V
5,6	0P	0P
7	MIN/MAX T.	Min/Max voltage supply alarm. With T.P.7 = L = int. protection. With T.P.7 = H = OK
8	DRIV. ALL.	Alarm for summation of the power stage driver protection. <u>With T.P.8 = L = int. protection.</u> <u>With T.P.8 = H = OK</u>
9	M.D.T.	Alarm absence or inverted tachogenerator. <u>With T.P.9 = L = int. protection</u> <u>With T.P.9 = H = OK</u>
10	S.T.	Alarm opening thermostats caused by interior overtemperature. <u>With T.P.10 = L = int. protection.</u> <u>With T.P.10 = H = OK</u>

POSITION	SIGNAL	DESCRIPTION
11	MAX. REC.	Alarm max dynamic bracking cycle in recovery. <u>With T.P.11 = L = int. protection.</u> <u>With T.P.11 = H = OK</u>
12	PWM.OK	Predisposed modulation. <u>With T.P.12 = L = OK</u> <u>With T.P.12 = H = modulation stopped</u>
13	REF.OK	Reference predisposed. <u>With T.P.13 = L = OK</u> <u>With T.P.13 = H = reference stopped</u>
14	RICH.PWM.	Modulation request. <u>With T.P.14 = L = modulation not request</u> <u>With T.P.14 = H = modulation request</u>
15	ACC/DEC.OK	Acceleration/Deceleration predisposed ramps. <u>With T.P.15 = L = ramps switched off</u> <u>With T.P.15 = H = ramp switched on</u>
16	± 10V.OK	Alarm lacking +-10V supply. <u>With T.P.16 = L = int. protection.</u> <u>With T.P.16 = H = OK</u>

**N.B.** With H and L logical voltage levels are intended.  
 H = 2/3 x 15V >=9-10V  
 L = 1/3 x 15V <=4-5V

### 4.1 Power wiring

**NOTE:** CD180 amplifier has several wiring connection which must be made in order to ensure the correct operation for reduce interferences. Use shielded cable for analogue and tachi signal. For wiring see cap. 7.1. Signals cables must be not together power wires, signals cables output should be own upper side power wiring output twisted together should be on lower side.

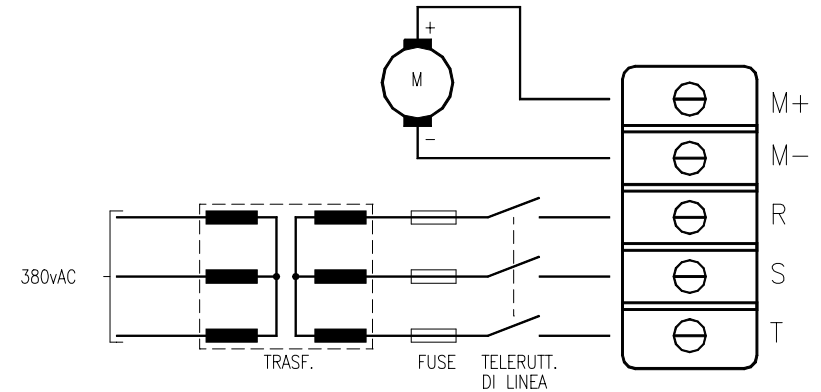

### 4.2 Signal wiring

