

ENFIELD

Z-DRIVE TRANSOM UNITS SERVICE MANUAL AND PARTS LIST

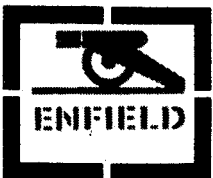
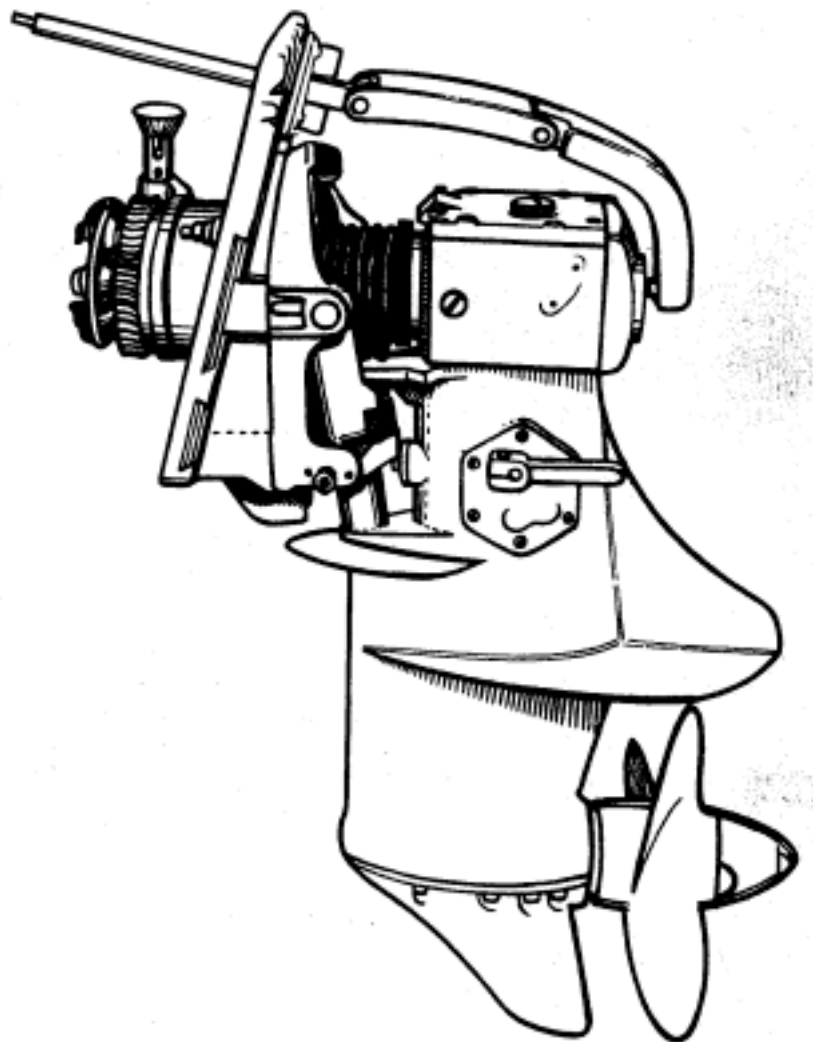

LEICESTER ENGLAND

ENFIELD

Z-DRIVE
TRANSOM UNITS

SERVICE MANUAL
AND
PARTS LIST
FOR
MODELS 130, 130H, 130NON SWIVEL



BOB KNOWLES PLANT SERVICES LTD.
MARINE DIVISION
9 VULCAN ROAD
LEICESTER LE5 5EF

TEL: 0116 253 8685
FAX: 0116 251 4977

ISSUE TWO APRIL 1980

PUBLICATION NUMBER 7768

PRINTED BY KALL-KWIK PRINTING
35 ORCHARD STREET, NEWPORT, TEL. 021010

CONTENTS

	Page
DESCRIPTION	4
DATA	5
OPERATING, LUBRICATION AND MAINTENANCE INSTRUCTIONS	6
INSTALLATION DETAILS	7
INSTALLATION INSTRUCTIONS	8
DIAGRAM, POWER TRIM-TILT	9
INSTALLATION HYDRAULIC LIFT KIT 130 NON SWIVEL	10
OVERHAUL SECTION	11
PARTS LIST	19-29
ILLUSTRATION, MODEL 130 Plate A	20
ILLUSTRATION, MODEL 130H Plate B	22
ILLUSTRATION, MODEL 130 NON SWIVEL Plate C	26
ILLUSTRATION, "Z-DRIVE", OUTSIDE VIEW (B)	24
ACCESSORIES	28-29

This booklet is published by BKPS LIMITED and every endeavour is made to ensure that the information contained in this manual is correct at the date of publication, but due to continuous development, the manufacturers reserve the right to make alterations without notice.

Sales and Service Enquiries should be directed to:

BOB KNOWLES PLANT SERVICES LTD.
MARINE DIVISION
9 VULCAN ROAD
LEICESTER LE5 5EF

DESCRIPTION

The ENFIELD "Z-DRIVE" transom unit is a transom mounted drive unit incorporating a reverse and reduction gear. It is suitable for adaption to either petrol or diesel engines within its power capacity.

Installation is easily accomplished, the standard mounting plate being arranged to suit a transom raked aft at 12° to the vertical. Where the transom is at a different angle an adaptor block is used.

DRIVE

Power from the engine is supplied through a flexible rubber-metal coupling to the drive unit input shaft. Two constant-velocity universal joints transmit the power to the top bevel gears and thence via the floating mainshaft to the gearshift bevels on the propeller shaft.

PROPELLER ROTATION

The standard propeller rotation is left hand, i.e. anti-clockwise looking forward when in forward gear. Rotation can be in the opposite direction so that contra-rotating twin units may be used.

ENGINE ROTATION

The "Z-DRIVE" transom unit is to be used on engines which rotate anti-clockwise when viewed from aft. Clockwise rotation

engines can be used providing manufacturers are informed when ordering.

GEAR CHANGE

An external lever, on the port side of the unit, controls the gear change by an internal linkage to the sliding dog clutch on the propeller shaft. A lock comes into operation automatically in the astern gear position to prevent the unit kicking up under reverse propeller thrust. The external gear change lever is arranged to suit a single lever control cable and quick release cable fittings are embodied. Gear positions are forward, neutral and reverse.

LUBRICATION

The unit must be filled with oil, up to the centre line of the input shaft. The filler plug Ref.169 is situated on the upper housing top cover, and the level plug is on the port side of the upper housing. Ref.172 **Plate.E**.

STEERING

Steering is by a tiller arm which is adaptable to either wire rope and pulleys or a proprietary push pull system.

TECHNICAL DATA

The unit serial number, consisting of 6 digits commencing with 2ZE, is found stamped on the port side of the Drive Housing. This

number should be quoted on all spares and service queries. The Power Trim Model carries its own serial number and the suffix "H".

	130	130H	130 Non Swivel
* Torque Capacity	140 lb. ft. torque at speeds up to 5500 rpm.		
Weight	90 lb. 41 kg.	95 lb. 43 kg.	90 lb. 41 kg.
Lubricating Oil Capacity	8.5 pt. 4.8 L	8.5 pt. 4.8 L	8.5 pt. 4.8 L
Type of Lubricant	E.P. 90	E.P. 90	E.P. 90
Oil for Power Trim	-	Automatic gear box fluid	Where hydraulic head lift is fitted use automatic gear box fluid
Reduction Ratio	1.65:1 or 2.0:1	1.65:1 or 2.0:1	1.65:1 or 2.0:1
Articulation: Lift Rearward (total) Trim Angle Forward Steering	55° 6° 34° (30° at steering arm)	55° 6° 34° (30° at steering arm)	55° 6° 34° (30° at steering arm)
Athwartships Rotation	135°	-	
Transom Angle	12°	12°	12°
Propellers (for further details see Page 28)	Small Spline 1 1/2 in. dia. to 14 in. dia.		

For a recommendation of propeller size, consult our Technical Sales Department

*Torque is given by Horse Power multiplied by 5250 divided by RPM at Horse Power Rating.

OPERATING, LUBRICATION AND MAINTENANCE INSTRUCTIONS

The Z-DRIVES are a transmission system for boats allowing a direct coupling to an engine without a gearbox being required. Also incorporated are steering and either a kick-up system or power trim.

STEERING

This is done usually with a proprietary push-pull system and the patented exterior linkage will require little maintenance.

GEARSHIFT

There are ahead, neutral, and astern positions of gear movement and the angle of movement and length of the Z-DRIVE operating lever are designed to suit one recommended stroke of a cable system. These systems have alternative strokes available by selecting a different anchoring hole on the control head.

Operation is simple. Select neutral once the engine is started and is idling at its operating temperature, the control head lever can be moved to engage the desired gear. Further movement of the control head lever will give an increase in engine speed but no further gear engagement.

The engine may be stopped when a gear is engaged but starting should always be when in neutral and no gear shifting should be attempted when the engine is NOT idling.

LUBRICATION

Before entering service and at regular intervals (20 hours or monthly, whichever is the shorter period) the oil level in the unit must be checked. The level plug is on the outside near the top of the Z-DRIVE body. The Power Trim Models have a dipstick in the transom plate. Should the colour of the lubricant become grey or creamy, contamination by water has occurred and the cause should be ascertained. The lubricant should be changed at least once per season.

ELECTROLYTIC CORROSION

As protection against galvanic action, the Z-DRIVE has a zinc block (5) fitted to the underside of the transom plate and a zinc ring

(218) just forward of the propeller. These should be inspected and replaced as they become eaten away.

A craft must be fitted with sufficient anodes to protect its own hull and fittings otherwise the whole sterndrive may act as such. Consultation with an expert on such anodes may be a wise precaution if in doubt.

NEVER use any paint on the hull or Z-DRIVE that contains copper.

PARKING MODEL 130 Z-DRIVE

If it is wished to leave the boat with the Z-DRIVES parked, adopt the following procedure:

Just before stopping the engine, engage astern. (This ensures that the drive will not slip off the reverse catch bar because the astern lock pin is under the catch). Pull on the plunger release cable to withdraw the locating plunger. The winding handle, when turned in the socket of the Z-DRIVE, will cause the body to swing sideways to starboard. (This will be possible in starboard direction only because of a stop plate on the swivel plate). Continue winding until the plunger re-engages. The Drive is then parked. For trailing support the Z-DRIVE body with ropes or blocks, etc.

POWER TRIM

Operation

If the system is correctly assembled, when the switch is pressed down the body will be trimmed inwards. This trimming will be finished when the rams are completely closed. There is no indication of this on the gauge but a change of note on the pump may be heard. Trimming out is achieved by pressing the switch upwards. If underway, a reading will be shown on the gauge (up to 600 p.s.i.) and when the needle swings quickly up to 1000 p.s.i. end of travel is reached. Continued operation under this condition will result in overheated wiring and damage.

Parking

It is recommended that the Power Trim Model Z-DRIVES are left parked with the bodies **down**. The rams are fully closed and there is no chance of marine growth on the piston rods.

INSTALLATION DETAILS

INSTALLATION OF DRIVE UNIT

The assembly is bolted through the transom which should be prepared as shown in *Figs. 1, 2,3,4,5.* It will also be noted that suitable reinforcing must be introduced to the transom. The drive unit is arranged to suit a standard transom angle of 12° although it is possible to accommodate other angles by making up a suitable adaptor block.

Generally speaking, it is recommended that the cavitation plate should be located within 0- $\frac{3}{4}$ inches (0 to 19 mm) below the keel (*see Fig. 2*).

On the 130 Z-DRIVE the out-drive unit should be installed initially with the locating tilt catch rod in the centre hole and the propeller shaft horizontal. A small angular adjustment of the propeller shaft with the rod in the other two holes is possible if it is found necessary to alter the trim. With fast single engine craft, where speeds over 30 mph (48 kph) are anticipated, it may be advisable to locate the engine and drive about $\frac{1}{4}$ inches (31.75 mm) off centre towards the port side to minimise torque reaction.

The distance between a pair of "Z-drives" will depend on the engines and their size, in the case of 130 "Z-drive" the minimum distance is more critical than with the 130H because when cranking up to the parked position (normal) the port unit must not foul the other.

STEERING GEAR

The tiller arm is adaptable to either a wire rope and pulley system or a proprietary push pull cable system, with 9 ins. (228 mm) travel. The special steering linkage does not have to be disconnected from the drive before swivelling to the parked position or when the unit is tilted.

REMOTE CONTROL

Remote control of both engine throttle and gear change is by means of a "single lever" control which is available as an optional extra with cable lengths up to 30 feet (9.14 metres) and all necessary fittings. For details of remote control cable kits available refer to Accessories Section. Page 27.

ELECTROLYTIC CORROSION

As the unit is of aluminium alloy construction, and copper alloys are commonly used in wooden boat construction, some trouble due to galvanic action should be anticipated unless precautions are taken.

It is recommended that an anti-fouling paint, as used with aluminium hulls and specifically free from copper, be applied to the bottom of the boat. This can also be used on the underwater part of the "Z-DRIVE" transom unit. Paints based on red lead should not be used.

A zinc sacrificial block is provided on the underside of the transom plate. The purpose of this block is to attract electrolytic erosion which would otherwise attack other "ZDRIVE" components. This sacrificial block should never be painted. As it is the normal function of the sacrificial block to erode, it should be replaced periodically, as necessary. A zinc ring is also fitted forward of the propeller.

A master switch should be fitted in the earthed lead between the battery and starter motor to isolate the engine when the boat is out of use. Care should be taken to avoid earthing the unit to the engine or other metal work with the mounting bolts, controls, steering gear, etc.

When connecting radio, echo sounding equipment, etc., check polarity of engine earth.

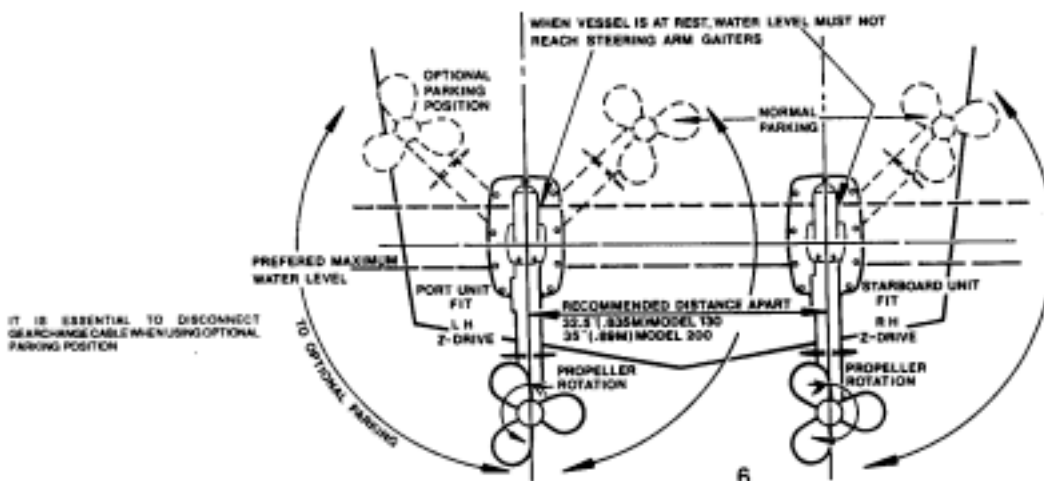

INSTALLATION INSTRUCTIONS

When assembling the "Z-DRIVE" transom unit to the craft for the first time, it may be an advantage to use the "Z-DRIVE" transom plate for marking off purposes.

Removal of Transom Plate from "Z-DRIVE" Unit

When new, there will be no oil left in the unit, but on all other occasions, before removing the transom plate from the "ZDRIVE", the oil must be drained.

The oil drain plug should be removed from the skeg, and the oil allowed to drain into a suitable clean container.

STANDARD MODEL 130

1. Loosen the jubilee clip around the gaiter over the universal joints (transom plate only). Engage reverse gear to lock reverse catchdown before removing swivel pins. Instruction 4.
2. Remove the screws holding the steering arm assembly to the transom plate. Withdraw the steering arm through the hole in the plate and allow the steering linkage to swivel away to one side.
3. Remove the two grub screws at the top of each leg of the swivel fork.
4. Tap outwards the two swivel pins connecting the fork to the swivel plate until the fork can swing away.
5. Move the gear lever to neutral which withdraws locking plunger from under reverse catch. The reverse catch can be pressed down and the body lifted away from the swivel plate.
6. Remove the flexible coupling wormwheel and worm-wheel housing from the transom plate.
7. The transom can be marked off according to the *Figs. 2 & 3*, and after some preliminary cutting of holes, the plate may be offered up for drilling.
8. When all the necessary holes have been cut in the transom, the plate can be attached together with the gasket using the "Z-DRIVE" bolting kit 8093.

POWER TRIM MODEL 130H

1. Loosen the clip around the gaiter over the universal joints (transom plate end only).
2. Remove the screws holding the steering arm assembly to the transom plate. Withdraw the steering arm through the hole in the plate, and allow the steering linkage to swivel away to one side.
3. Remove circlips off the end of the shaft on which the hydraulic cylinders are mounted, withdraw the shaft to one side, retaining the nylon and stainless steel washers as this is done. Note the order in which they are assembled. It is most important that the hydraulic cylinders are not rotated when at the innermost extreme of travel.
4. Loosen the allen screws found on the top of each leg of the swivel fork.
5. Tap outwards the two swivel pins connecting the fork to the transom plate, until the latter is free. The transom plate can now be handled separately from the "Z-DRIVE" body, which can be put on one side until required.
6. The transom can be marked off according to *Fig.4* and after some preliminary cutting of holes, the plate may be offered up for drilling.
7. When all the necessary holes have been cut in the transom, the plate can be attached together with the gasket using the "Z-DRIVE" bolting kit 8093.

130 NON SWIVEL MODEL

1. To remove Transom Plate from Drive Leg follow instructions as for Standard 130 instructions 1 to 5. Cut hole in Transom of Boat according to *Fig.5*. Place Transom in cut out position correctly for height from bottom of boat to centre of input shaft *Figs.3 & 5*. When all the necessary holes have been drilled the Transom Plate can be attached together with the Gasket using the Z-Drive bolting kit 8093.

ELECTRICAL CIRCUIT

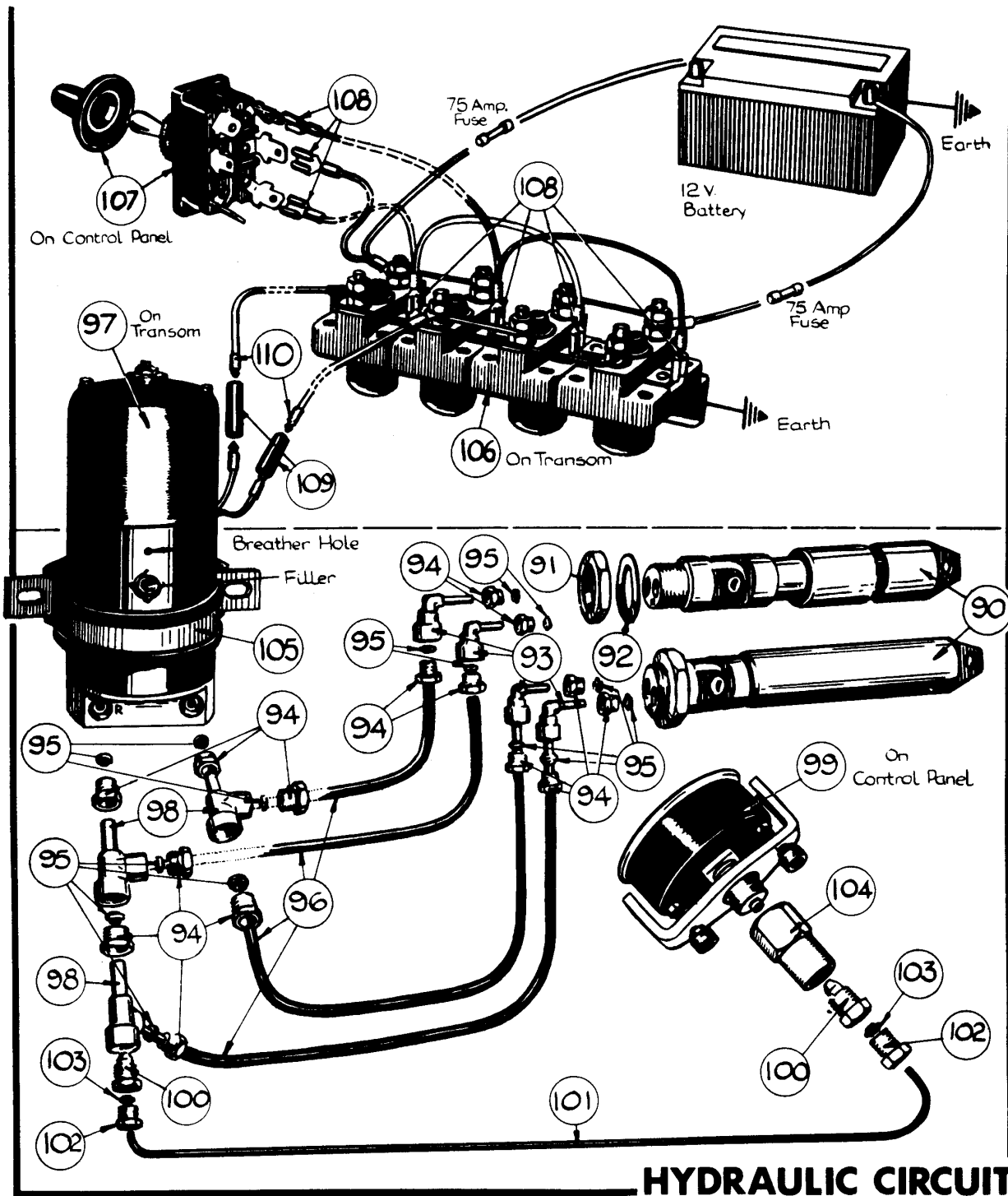

HYDRAULIC CIRCUIT

INSTALLATION HYDRAULIC LIFT KIT 130 NON SWIVEL Z-DRIVE

If the Hydraulic Hand Lift is to be used. Before placing Cylinder into Recess Housing draw Piston from Cylinder close valve on Pump and Prime Hose and Cylinder until oil is level with 'O' Ring at top of Cylinder, Position Piston into oil open Release Valve on Pump and press down Piston to end of

Cylinder. Smear Cylinder liberally with water proof grease and position into Recess in Transom Plate. The system is now ready to lift unit to parked position. When unit is in the lift position for long periods or storage the unit should be supported with rope or blocks etc.

OVERHAUL SECTION

1. Transom Plate Assembly - 130
2. Transom Plate Assembly - 130H. 130 Non Swivel.
3. Swivel Fork
4. Hydraulic Trim Tilt Equipment
5. 130 "Z-DRIVE" Housing, Lower
6. 130 "Z-DRIVE" Housing, Upper
7. Checking for Backlash

INTRODUCTION

Disassembly of the "Z-DRIVE" transom unit for inspection may be accomplished by following the procedures outlined below:

1. Transom Plate Assembly:
2. Drive Housing
 - (a) Lower
 - (b) Upper

1. TRANSOM PLATE ASSEMBLY

When the disassembly procedure for any given section has been completed, any further disassembly indicated by inspection may then be carried out by following in detail the necessary additional procedures. When removing or refitting ball and roller bearings, it is recommended that the housings, etc., should be heated in water to maintain manufacturing tolerances, and so avoid possible loosening of the bearings in the housings.

When re-assembling the unit, all gaskets and 'O' rings must be removed. Dirt is a major cause of wear and failure; therefore, conduct all maintenance operations in an area which is as clear and clean as possible. Place the disassembled parts on a clean surface and if they are to remain for an extended period of time, cover exposed-surfaces, which can be contaminated by salt air, etc. For parts identification numbers refer to the illustrations contained in the Parts List section.

The following instructions assume that the unit has been removed from the craft. For ease of dismantling the unit can be split into two parts. These are (1) the Transom Plate and (2) Drive Housing. To accomplish this the following procedure should be adopted:

Drain off the oil into a clean container.

TRANSOM PLATE ASSEMBLY 130

To Disassemble the Transom Plate Assembly

If the transom plate assembly has been removed from the craft with the close coupling components still connected, remove these first.

Knock back the tabwashers (61) locking the set screws (60) that hold the flexible couplings (59) to the input shaft (55). Unscrew the bolts (60) and remove the flexible coupling (59).

Undo the nut (57) on the universal coupling input shaft (55) and remove with the washer (58). The input shaft (55) can now, without the aid of special tools, be pulled out of the transom plate. It will bring with it the inner race to the roller bearing (21). Using a suitable drift, the universal coupling **shaft** (56) can be tapped through its ball bearing (22) in the opposite direction to which the input shaft was removed.

The oil seal (24) and bearings (21) in the swivel hub (20) can be inspected and if necessary changed.

Removal of Swivel Hub from Transom Plate

Remove from the hub the six socket screws (42), (retaining the wormwheel). (41)

Remove the seven socket screws (40) that retain the wormdrive housing (33) to the transom plate (1)

Rotate the swivel plate (44) and hub (20) so that the lug clears the hook in the transom.

Undo the six nuts (51) or the countersunk screws (54) and withdraw the swivel plate from the hub.

Using a suitable drift on the inboard end of the swivel hub (20) tap the swivel hub through the transom plate (1) in a rearwards direction. When the hub is clear, the sealing 'O' rings (29, 30) and nylon thrust washer (32) and bearing strips (31) will be evident and can be removed.

It is not necessary to remove the swivel hub (20) to replace the front oil seal (24) as this can be done after the input shaft (55) has been removed.

If the bearings roller (21) and ball (22) require renewal, the swivel hub (20) must be heated such as in boiling water and the bearings tapped clear with a drift or extractor.

The ball bearing (21) is retained by circlip (23) which should be removed before the bearing (21) is withdrawn.

The new bearings are pressed home hard against their locating shoulders with the bearings (22 & 21) cold and the hub (20) hot as before. If the oil seal (24) has been removed a new one may be fitted at this stage but after the hub (20) has cooled.

The 'O' rings (29 & 30) should be inspected and renewed if necessary. The washer (32) is located in its correct position and the nylon strips (31) fitted into their respective grooves. An application of a suitable water resistant graphite containing grease should be applied to the outer diameters.

The swivel hub is replaced within the transom plate, taking care that the nylon strips remain within their grooves as this is done.

THE SWIVEL PLATE ASSEMBLY

The only items on the swivel plate that may require replacing from time to time are the buffer (46), the two bushes (45), the rod (47) and nuts (48) left. In addition to these there is the swivel plate stop (49) with its screws (50) which may be moved to the opposite side of the swivel plate to allow for swivelling for parking in the opposite direction to that normally used.

NOTE: If this parking procedure is adopted, it is necessary to disconnect the gear change cable before parking to avoid damage to the cable.

To remove the buffer (46) merely unscrew as if it were a small bolt. Re-fit a new one, making sure that it is screwed up tight.

To renew the swivel bushes (45), place the swivel plate somewhere where the part of the plate that contains the bush can be adequately supported.

While using a suitable drift the bush is pushed through with a press or gently tapped through using a hammer.

The reverse is the procedure for fitting the new bushes but ensure that they do not protrude either side of the lugs.

The reverse catch rod (47) is normally positioned in the middle of the three holes but can be removed and used in either of the other two, whichever appears to give the best boat performance.

The removal of this bar can be done at any time and does not necessitate the dismantling of the "Z-DRIVE". If one of the nuts (48) is undone, the bar can be slid out sideways and re-fitted into whichever of the holes is thought to be the best position.

To re-fit the swivel plate assembly to the transom plate, the plate has to be slid over the spigot on the swivel hub and at the same time the lug at the bottom of the swivel plate engaged within the hook of the transom plate. The swivel hub is then rotated to align the holes within its flange with those on the swivel plate. The nuts (51) or countersunk screws (54) are re-fitted.

RE-FITTING THE WORMDRIVE HOUSING

The seven socket head screws (40) are fitted through the worm drive housing (33) and into the forward face of the transom plate (1). This is done with the cone pointing vertically upwards. The wormwheel is then attached to the swivel hub by six socket head screws (42). The constant velocity joint is tapped, from the rear, through the ball bearing (22) until fully home.

The input shaft (55) is fitted from the front of the transom, engaging with the splines of the constant velocity joint (56) and care should be taken when it is passing through the oil seal (24).

If the roller bearing (21) has been replaced within the swivel hub, the inner race previously fitted must be removed and the inner race to the new bearing fitted. Races and bearings are not interchangeable.

The input shaft is tapped along the shaft of the constant velocity joint until itself is hard against the bearing.

The washer (58) and nut (57) are then fitted on to the exposed thread of the constant velocity joint, the nut is tightened to 140 lb. ft. torque. The flexible coupling (59) screws (60) tabwashers (61) may now be re-fitted to the input shaft.

2. TRANSOM PLATE ASSEMBLY 130H 130 NON SWIVEL

Disassembly of the Transom Plate

Dismantle the input coupling (59) from the input shaft (55) by removing the set-screws (60), plain washers (62) and tab washers (61, 68).

Remove the input shaft nut (57) and washer (58) from the internal bore of the input shaft. Using a soft drift, carefully drive out the constant velocity joint (56) from the input shaft. Using a suitable press, remove the input shaft from its bearings (21). After removal of the circlip (23) press out the bearings (21) and (22) and seal (24) from the transom plate.

The ball bearing (21) is retained by circlip (23) which should be removed before the bearing (21) is withdrawn.

The new bearings are pressed home hard against their locating shoulders with the bearings (22 & 21) cold and the hub (20) hot as before. If the oil seal (24) has been removed a new one may be fitted at this stage but after the hub (20) has cooled.

The 'O' rings (29 & 30) should be inspected and renewed if necessary. The washer (32) is located in its correct position and the nylon strips (31) fitted into their respective grooves. An application of a suitable water resistant graphite containing grease should be applied to the outer diameters.

The swivel hub is replaced within the transom plate, taking care that the nylon strips remain within their grooves as this is done.

THE SWIVEL PLATE ASSEMBLY

The only items on the swivel plate that may require replacing from time to time are the buffer (46), the two bushes (45), the rod (47) and nuts (48) left. In addition to these there is the swivel plate stop (49) with its screws (50) which may be moved to the opposite side of the swivel plate to allow for swivelling for parking in the opposite direction to that normally used.

NOTE: If this parking procedure is adopted, it is necessary to disconnect the gear change cable before parking to avoid damage to the cable.

To remove the buffer (46) merely unscrew as if it were a small bolt. Re-fit a new one, making sure that it is screwed up tight.

To renew the swivel bushes (45), place the swivel plate somewhere where the part of the plate that contains the bush can be adequately supported.

While using a suitable drift the bush is pushed through with a press or gently tapped through using a hammer.

The reverse is the procedure for fitting the new bushes but ensure that they do not protrude either side of the lugs.

The reverse catch rod (47) is normally positioned in the middle of the three holes but can be removed and used in either of the other two, whichever appears to give the best boat performance.

The removal of this bar can be done at any time and does not necessitate the dismantling of the "Z-DRIVE". If one of the nuts (48) is undone, the bar can be slid out sideways and re-fitted into whichever of the holes is thought to be the best position.

To re-fit the swivel plate assembly to the transom plate, the plate has to be slid over the spigot on the swivel hub and at the same time the lug at the bottom of the swivel plate engaged within the hook of the transom plate. The swivel hub is then rotated to align the holes within its flange with those on the swivel plate. The nuts (51) or countersunk screws (54) are re-fitted.

RE-FITTING THE WORMDRIVE HOUSING

The seven socket head screws (40) are fitted through the worm drive housing (33) and into the forward face of the transom plate (1). This is done with the cone pointing vertically upwards. The wormwheel is then attached to the swivel hub by six socket head screws (42). The constant velocity joint is tapped, from the rear, through the ball bearing (22) until fully home.

The input shaft (55) is fitted from the front of the transom, engaging with the splines of the constant velocity joint (56) and care should be taken when it is passing through the oil seal (24).

If the roller bearing (21) has been replaced within the swivel hub, the inner race previously fitted must be removed and the inner race to the new bearing fitted. Races and bearings are not interchangeable.

The input shaft is tapped along the shaft of the constant velocity joint until itself is hard against the bearing.

The washer (58) and nut (57) are then fitted on to the exposed thread of the constant velocity joint, the nut is tightened to 140 lb. ft. torque. The flexible coupling (59) screws (60) tabwashers (61) may now be re-fitted to the input shaft.

2. TRANSOM PLATE ASSEMBLY 130H 130 NON SWIVEL

Disassembly of the Transom Plate

Dismantle the input coupling (59) from the input shaft (55) by removing the set-screws (60), plain washers (62) and tab washers (61, 68).

Remove the input shaft nut (57) and washer (58) from the internal bore of the input shaft. Using a soft drift, carefully drive out the constant velocity joint (56) from the input shaft. Using a suitable press, remove the input shaft from its bearings (21). After removal of the circlip (23) press out the bearings (21) and (22) and seal (24) from the transom plate.

This will enable the main body of the "ZDRIVE" to be lifted clear of the hydraulic cylinders. Now, from inside the hull, unscrew the two tubing nuts (94) which hold the oil supply and return pipes to each cylinder, and remove the pipes.

Now undo the large nut (91) with nylon washer (92) and remove.

It will be necessary to keep the main body of the "Z-DRIVE" lifted out of the way whilst the hydraulic cylinders are removed.

Checking the Hydraulic Cylinder Units for Leakage

A simple method of checking the hydraulic cylinder and pumps for leakage and to observe that the cylinders and pumps function

correctly is to re-connect the pipes (96) to the hydraulic cylinder.

The hydraulic units can now be suitably clamped and operated several times to both extremities to remove air inclusions, checking that the pump reservoir is correctly filled to the level of the oil filler hole.

It will be observed whether leakage occurs at the knuckle joint seals, piston rod seals, or any of the pipe connections.

If new rings are fitted into the grooves in the hinge tongue, the hinge fork must be very carefully fed over the tongue.

The parts should be well lubricated with oil before starting to re-assemble, making sure that absolute cleanliness is maintained.

Re-fit the pivot pin.

5. MODEL 130/130H/130 NON SWIVEL

To Disassemble the Drive Body (Lower)

Knock back the tabs on the locking washer and turning anti-clockwise remove the propeller shaft spinner nut. Withdraw the propeller and distance piece from the propeller shaft (204).

Remove the clutch operating lever pivot pin (155) and sealing washer (156) from the skeg. Remove the two socket screws (219) and withdraw the zinc ring (218) from within the boss surrounding the propeller shaft.

Release and remove the ten socket screws (163) and sealing washers (129) which secure the skeg (162) to the body (161) and remove the skeg.

Remove the split pin (144) from this gear change operating rod (150, 151). In the case of R.H. rotation units - drawing section F F refers to Plate A. Remove clutch operating lever (153) together with the dog clutch operating fork (154).

Lift the propeller shaft (204) complete with bearings, bevel gears, thrust washers, seal and dog clutch from the housing.

Withdraw the seal circlip (217) and seal (213) complete with housing (214) from the rear end of the propeller shaft. Using a suitable extractor remove the ball bearing (166) from the rear end of the propeller shaft. It will now be possible to remove the rear thrust washer (211), rear bevel gear (210), rear bevel gear bush (205), dog clutch (212), front bevel gear (205) and front thrust washer (211) from the propeller shaft. Remove the front bearing circlip (209) and bearing spacer (207). Press off the front bearing (206) and remove the second spacer (208), circlip (209) and front bevel gear bush (205) from the propeller shaft.

Loosen clamp screw (136) and remove the gear change operating lever (135) and key (132) - See Section C - C Plate A illustrated.

Remove the plug (139), washer (140), spring (138) and gear change locking plunger (137) from the gear change lever shaft bearing (126) or in the case of R.H. rotation units (126A). Remove circlip (85) and thrust washer (134) from the gear change lever shaft.

Release and remove the six screws (40), sealing washers (128) and plain washers (129) securing the gear change lever shaft bearing (126) to the housing. Remove the bearing and joint (127) from its location.

Withdraw the pin (141) which connects the operating lever (133) to the astern lock operating fork (142). See section D D Plate A, not present on 130H.

Disconnect the gear change operating rod (150) or (151) on R. H. rotation units from the gear change lever (133) by removing the securing pin (149) and withdraw the operating rod and lever from the unit.

Remove the 'O' ring (131) and circlip (85) from the gear change lever shaft (130). The shaft can now be pressed out of the gear change lever and the woodruff key (132) removed.

Note: Position of lever reversed on R.H. rotation units.

Withdraw the astern lockpin (145) and fork (142) from the lockpin bush (175). Remove the split pin (144), washer (143) and fork (142) from the astern lockpin.

Release and remove the two setscrews (196), washers (197) and vertical drive shaft retainer (195) from the housing. Using a suitable extractor remove the bottom bevel gear (193) from the vertical drive shaft and bearings.

The vertical drive shaft (194) can now be removed, care being taken to prevent the removable collar (198) from falling and becoming lodged in the housing.

With a suitable extractor remove the roller bearing (165) and ball bearing (166) from the bottom of the housing. Disassembly of the drive housing (lower) comprising the skeg bottom bevel gears and the lower housing, is now complete.

Before inspection and reassembly, all parts should be thoroughly washed in clean paraffin. Carefully inspect all components for wear, pitting and cracks, etc. Renew all parts considered unserviceable

To Reassemble the Drive Body (Lower)

Using a suitable press, fit the bottom bevel drive gear ball bearing (166) and roller bearing (165) to the body (161) ensuring that each bearing is fitted in to the full extent of its recess.

Refit the vertical drive shaft (194) with collar (198) into the drive housing and using a press, fit the bottom bevel drive gear (193) into the roller bearing (165) and ball bearing (166).

Fit the vertical drive shaft retainer (195) to the housing and secure with the two setscrews (196) and washers (197).

Fit the 'O' ring (176) into the astern lock pin bush (175) and refit the bush and sealing washer (169) into the body (161). Refit the fork (142) and washer (143) to the astern lock pin (145) and secure with split pin (144). Assemble the lock pin into the bush.

Fit the woodruff key (132) to the inner end of the gear change shaft (130) and using a suitable press, assemble the gear change lever (133) to the shaft and secure with the circlip (85).

Place the gear change operating rod (151) (151 R.H. rotation unit), in position in the housing and connect the gear change lever (133) to the rod with the pin (149).

N.B. As the assembly of this item varies according to direction of rotation, it should be noted that the above instructions refer to the L.H. rotation unit and is illustrated in the main drawing whilst the assembly of the R.H. rotation unit is illustrated in Section F F -Plate A.

fitment of the gear change shaft bearing (126) and (126A) as this varies with left or right hand rotation units.

Assemble the thrust washer (134), circlip (85) and woodruff key (132) to the gear change shaft.

Fit the locking plunger (137), spring (138), washer (140) and plug (139) to the rear change shaft bearing (126) or 126A on R.H. rotation units.

Fit the key (132) and the gear change operating lever (135) to the shaft (130) and secure with the clamp screw (136).

N. B. It should be noted that on L.H. rotation unit the lever will point aft, whereas on a R.H. one it will point forward; two key-ways are provided on the shaft for this purpose.

Onto the front end of the propeller shaft (204) assemble the front bevel gear bush (205), the rearmost of the two circlips (209) and bearing spacer (208) then press on the front bearing (206), fit the foremost spacer (207) and secure with the second circlip (209).

Onto the rear end of the shaft assemble the front bevel gear (210), the dog clutch (212), the rear bevel gear (210) and the rear thrust washer (211), press on the rear bearing (166) and fit the propeller shaft seal (213), complete with housing (214) and 'O' ring (215).

To ensure that the bearing (166) is correctly positioned, place the assembled propeller shaft in its location in the housing, ensuring that the seal housing locating pin (216) engages with the locating hole in the seal housing (214). Check that clearance exists between the front face of the bearing and the rear face of the rear bevel gear thrust washer (211), and also between the rear face of the bearing and the front face of the seal housing (214).

With the propeller shaft assembly correctly positioned, check the backlash between the bottom bevel drive gear (193) and both propeller shaft bevel gears (210). Clearance between these gears should be within the limit of 0.008 in to 0.012 in. (0.20/0.30 mm). Should the backlash require adjustment, thrust washers (211) of the required thickness should be fitted to bring the backlash within the above limits.

When the dog clutch operating fork (154) is in the groove of the dog clutch, place the clutch operating lever (153) in position. Connect it to the gear change operating rod (150), (151 for R.H. rotation units) and secure with the split-pin (152).

Connect the gear change lever to the astern lock operating fork (142) with the pin (141). (Not on 130H).

Fit the 'O' ring (131) to the gear change lever shaft and using a new joint (127) fit the gear change shaft bearing (126) (126A for R.H. rotation) to the housing and secure with the six screws (40), sealing washers (128) and plain washers (129).

N. B. Refer to illustration for correct method of

The faces of the skeg and housing are

machined flat. On these units when re-fitting the skeg a suitable jointing compound should be used. Place the skeg (162) in position on the housing, ensuring that the tabs on the thrust washers (211) locate in their respective slots in the skeg. Secure the skeg with the ten socket screws (163) and sealing washers (129). Fit the rear seal housing retaining circlip (217).

Fit the clutch operating lever pivot pin (155) and washer (156) to the skeg, ensuring that it is correctly located in the clutch operating lever (153).

Replace the zinc ring (218) in the boss surrounding the propeller shaft and secure with two socket screws (219).

Refit the distance piece, propeller, lock washer and spinner nut. With the spinner effectively tightened, secure with the locking washer tabs.

Refill the unit to the correct level with oil. Oil capacity of the unit is 8½ pints (4.8 litres). E.P. 90 gear oil should be used.

6. To Disassemble the Drive Body (Upper)

Remove the eight screws (171) securing the top cover (167) to the housing and remove the top cover and joint (170).

Remove the six socket screws (140) and spring washers (179) which retain the bevel gear bearing housing (177) to the body. Withdraw the bearing housing and joint (178) from the body.

Using a suitable extractor, carefully remove the bevel gear (192), roller bearing (165) and ball bearing (166) from the bevel gear bearing housing (177).

Remove the circlip (203) from the universal joint and input shaft assembly (199). Using a suitable press, remove the universal joint from its bearing (22).

Remove the two circlips (23) from the housing and press the universal joint shaft bearing (22) from the housing.

Withdraw the vertical drive shaft bevel gear (192). Before the bearings (165 and 166) can be removed, the vertical drive shaft (194) and collar (198) must be withdrawn. This can be accomplished by dismantling the lower housing as described in the earlier section. The vertical drive shaft can be withdrawn and using a suitable extractor, remove the vertical drive shaft bevel gear (192), roller bearing (165), ball bearing (166) and collar (198) from the housing.

If renewal of the centre swivel pin bushes (45) is intended, press out in the normal manner.

Thoroughly clean and inspect all components for wear, pitting and cracks, etc. Renew worn or defective parts.

To Reassemble the Drive Housing (Upper)

If the centre swivel bushes (45) have been removed for renewal, fit new bushes.

Fit the ball bearing (166) roller bearing (165) to the housing, ensuring that the bearings are fitted to the full extent of their recesses. Replace the vertical drive shaft (194) and ensure that collar (198) is correctly positioned and reassemble the lower housings, as described in the earlier section. Re-fit the vertical drive shaft bevel gear (192).

Fit the inner bearing circlip (23) to the housing and fit in the universal joint shaft bearing (22). Fit the second of the circlips (23).

Press the universal joint and input shaft assembly (199) into its bearing (23) and secure with the circlip (203).

Fit the ball bearing (166), roller bearing (165) and bevel gear (192) to the bevel gear housing (177) ensuring that the races fit in to the full extent of their recesses.

Fit the bevel gear bearing housing (177) to the body (161) using a new joint (178) and secure with the six socket screws (40) and spring washers (179). With the aid of a feeler gauge, check the backlash between the top bevel gear and the vertical drive shaft bevel gear. Clearance between these two gears should be within the limit of **0.008 in to 0.012 in.** (0.20/0.30 mm). Adjustments to the clearances is obtained by the addition of extra joints (178) to the bevel gear housing (177).

Assemble the top cover (167), using a new joint (170) to the housing and secure with the eight screws (171).

7. CHECKING FOR BACKLASH

Re-fit into bearings in bearing housing top bevel gear (220). Slip gear (221) into bearings at the top of the housing. With two joints (178) offer the bevel gear housing with the gear up to the body. Check as follows:

- (F.) When looking at the inner faces of the gear, not the teeth, ensuring that the edges of the teeth are in line with the edges of the teeth of the mating gear.
- (b) When a clock gauge is mounted with its stylus on the pitch circle diameter, the other gear being held, the reading given should be 0.008 in. - 0.312 in. (min. to use).

To correct for (a) :-

It is unlikely with minimum shimming to start with that either gear will be too high, so the first step is to observe which gear has teeth whose faces are behind those of mating gear. The gear that has such teeth requires **additional** shimming.

To correct for (b) :

However, when faces are in line, backlash may not be correct. If it is too much, additional shimming will be necessary on **both** gears.

If it is too little, shimming has to be taken away from both gears. On vertical gear (221) shim is put between gear and ball bearing. For top input gear (220)

shimming is done by using extra joints (178)

On ahead and astern gears (238) on propeller shaft assembly, adjustment is made by fitting different thickness of thrust washer (236).

When backlash is correct, the assembly may continue:

Slip vertical bevel gear (221) on vertical driveshaft (223). Re-fit washer (225) and setscrew (226).

Holding hose clip (189) loosely over gaiter (190) put gaiter over spigot provided on the body (180) and tighten clip to seal.

Using soft-faced mallet, tap constant velocity joint (227) through ball bearing (22) until shoulder of joint is hard against bearing. Fit retaining circlip (203) into groove on shaft. The assembly of parts in bearing housing may be re-fitted and held in place with six screws (40) and washers (179). Top cover (167) with gasket (170) is fitted back into place and fixed with screws (171).

PARTS LIST

METHOD OF IDENTIFYING AND ORDERING SPARE PARTS

The Parts List contains the numbers and descriptions of all parts comprising the Model 130, 130H, 130 Non Swivel Transom Units, together with a Supplementary Section giving those of the recommended propellers and other principal accessories. (For further details of Accessories, see separate leaflet).

IDENTIFICATION

Each part contained in the Unit is located in its section in columns headed as follows:

Ref. No.

Relates the item concerned to its position on the drawing.

S or N.S.

'S' indicates that the item in question is available as a spare part.

'ICS.' indicates that the item is not available as a spare part by itself.

(for various reasons, some sub-assemblies or component parts can ONLY be supplied in the complete assembly. It is therefore necessary, before ordering, to determine whether or not the part required is, in fact, available separately).

Qty. Req.

Indicates the total quantity of the particular item in the assembly, or group, in which it is contained.

Part No. & Description Is self-explanatory.

Remarks Contains supplementary notes and information.

As a guide for use of the Parts List, the following examples are given:

1. Locate the item required and its Ref. No. on the drawing.
- 2 Locate the Ref. No. in the list, so as to check whether 'S' or 'ICS.' determine quantity, and ascertain part number and description.
 - (a) If the part is indicated 'S', then it can be ordered separately, e.g. Ref. No. 7 in the Transom and Swivel

Plate Assembly on Page 18 is read as:
33432309 Sleeve, Swivel Plate
Locking Plunger
This is indicated 'S' and, therefore, is available as a spare part.

- (b) If the part is indicated 'ICS.' then it can only be supplied inside its containing assembly, e.g. Ref. No. 112 in the Steering Linkage Section on Page 22 is read as:
7067 Link, Steering Upper
This is indicated 'ICS.' and can ONLY be supplied inside the assembly of which it is part. This assembly is covered by the first number in the next left hand column reading upwards which is:
7225 Assembly Link and Bushes
and is the one that should be ordered.

ORDERING

When ordering parts, it is imperative to quote the serial number of the Unit and to specify the part number, description and quantity of the items required. If in doubt, then the reference numbers should also be given to facilitate identification by your Dealer.

The Unit serial number will be found stamped on the port side of the Drive Housing; it consists of six digits, commencing 2ZE. The power trim model has its own suffix H. We would again stress the importance of always quoting the number and giving complete information if parts orders are to be promptly expedited.

All enquiries relating to parts and accessories should be addressed to:

**BOB KNOWLES PLANT SERVICES LTD.
MARINE DIVISION
9 VULCAN ROAD
LEICESTER LE5 5EF
TEL: 0116 253 8685
FAX: 0116 251 4977**

Ref. No.	S or NS	Qty. Req.	For NS Model	Part No.	Description	Remarks
-	S	1	130 only	37814125	TRANSOM & SWIVEL PLATE ASSEMBLIES	
)	NS	1		37537182	Assembly, transom plate comprising:-	
2	S	10		32815117	Transom Plate	
3	S	1		32114126	Pin, Nylon	
4	S	1		7055	Plug Breather	
5	S	1		36131314	Nipple, Greasing	
6	S	1		2224568	Block, zinc	
7	S	1		33432309	Screw, zinc block to transom plate	
8	S	1		33432309	Sleeve, swivel plate locking plunger	
9	S	1		2725499	Circlip, sleeve locating	
10	S	1		37811111	Plunger pin and 'O' ring asst'.	
11	S	1		32815117	Pin, nylon	
12	S	1		31744128	Spring	
13	S	1		2415702	'O' ring	
14	S	1		36285105	Fork end plunger release	
15	S	1		32713113	Pin, shackle, cable	
16	S	1		2221281	Grub screw	
17	S	1		2131037	Washer	
18	S	1		2117269	Split pin	
19	S	1	130 only	36863113	Gasket "Z-DRIVE" to transom	
20	S	1	130 only	710947	Swivel hub assembly, comprising:-	
21	S	1		33426381	Hub, swivel	
22	S	1		2546106	Bearing, roller, input shaft	
23	S	1		0040020	Bearing, ball, input shaft	
24	S	1		2721790	Circlip locating bearing	
25	S	1		2415507	Seal input shaft	
29	S	1		2415821	'O' Ring - rear (Swivel hub to transom plate)	
30	S	1		33824117	'O' Ring - front (Swivel hub to transom plate)	
31	S	2		36841412	Strip (Swivel hub to transom plate)	
32	S	1		33822406	Thrustwasher (Swivel hub to transom plate)	
-	S	1		710914	Assembly, housing worm drive and assembly worm and shaft comprising:-	
33	S	1		710951	Assembly worm drive housing	
34	S	1		37522441	Housing, worm drive	
35	S	2		2513089	Bush, worm drive housing	
36	S	1		32456408	Shaft, worm drive	
37	S	1		31173109	Worm gear	
38	S	2		2513970	Thrust washer, worm drive	
39	S	2		2115261	Pin worm to shaft and tube assembly to shaft.	
40	S	1		37442415	Tube assembly	
41	S	7		2222712	Socket screw, worm drive housing to transom plate.	Stainless
42	S	1		31173201	Wormwheel	
43	S	6		2222712	Socket screw	Stainless
44	S	1		710915	Handle, cranking asst'.	
45	NS	1	130 only	710938	Assembly, swivel plate comprising:-	
46	S	1		38167553	Plate swivel	
47	S	2		2513911	Bush top pins/swivel fork to plate	
48	S	1		2634018	Buffer, swivel plate	
49	S	1		32524137	Rod, locating catch - swivel fork	
50	S	2		2211284	Nut, retaining rod	
51	S	1		36113133	Plate, stop - swivel plate	
52	S	2		2222712	Screw - plate to swivel plate	
53	S	6		7349	Set screw swivel plate retaining	Stainless
54	S	6		2131041	Washer - to swivel hub	Stainless

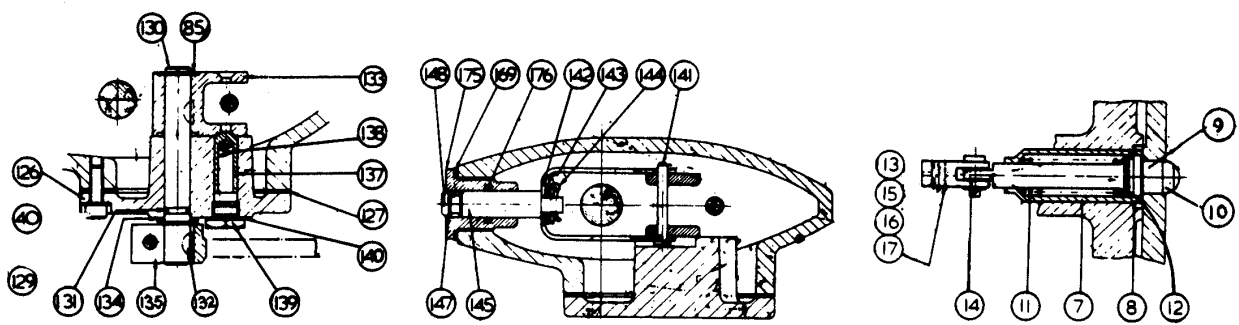

Section C-C

Section D-D

Section E-E

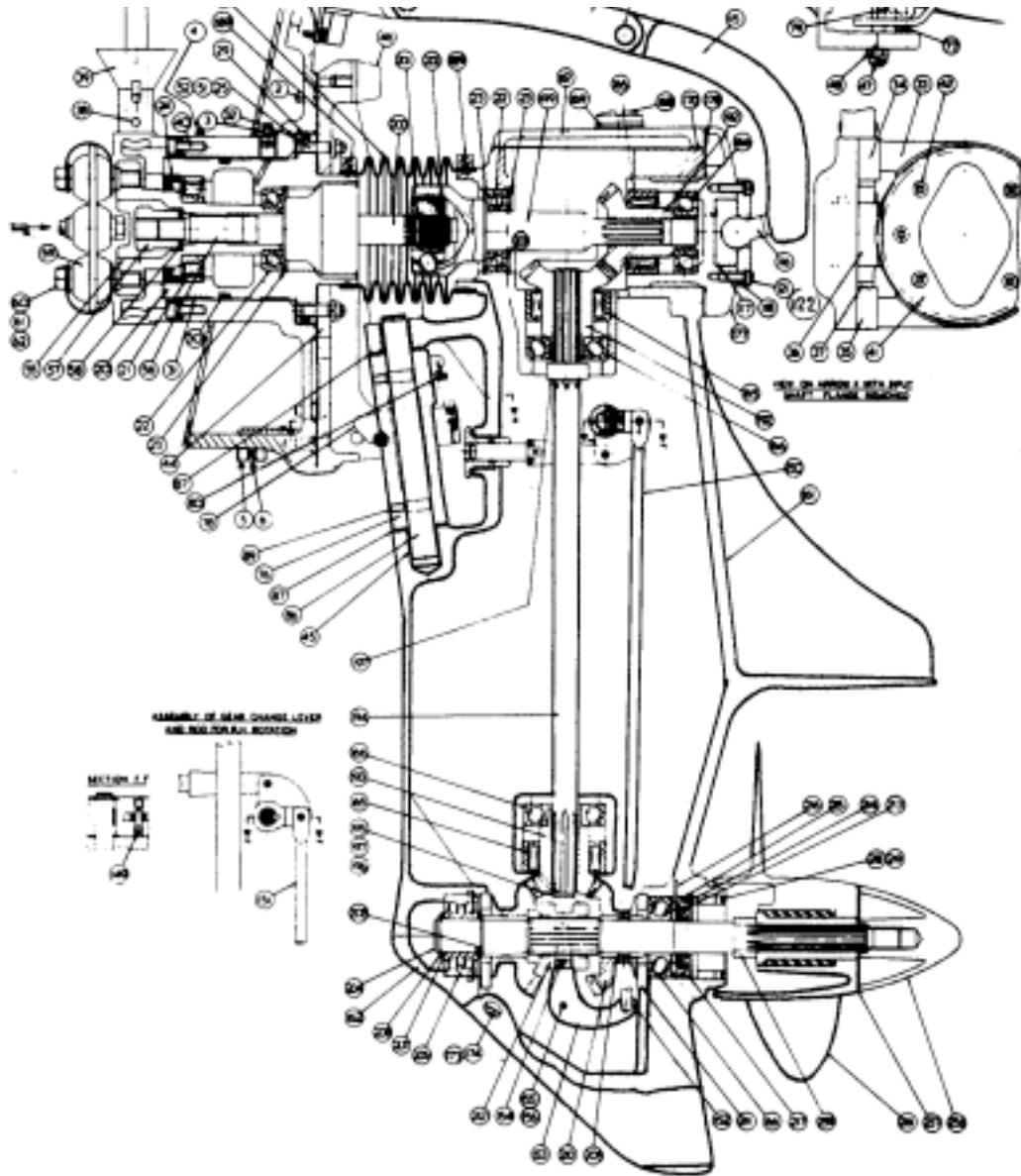

Plate A Model 130 Assy.

Ref.	S No.	Qty. or Req.	For NS Model	Part N ^o ,	Description	Remarks
TRANSOM & SWIVEL PLATE ASSEMBLIES						
	55	S1	130/130H	37466511	Shaft input (contd)	
	56	S1		2584601	C.V. Joint - input	
	57	S1		33531116	Nut. C.V. Joint to input shaft	
	58	S1	130	33121412	Washer. C.V. Joint to input shaft	
	59	S1	Non swivel	2581215	Coupling, flexible	
	60	S2		0096635	Setscrew - Coupling to input shaft	
	61	S2		36478311	Tabwasher - Coupling to input shaft	
	62	S2		2131043	Washer, plain - Coupling to input shaft	
	69	S1	130H	7285	Assembly Transom Plate, with 5, 6, 45,	
	70	S1	130	7003	21, 22, 23, comprising:-	
	71	S1	Non swivel	7074	Transom plate	
	72	S1		W18275	Oil filler neck extension	
	73	S2		DE2010	Oil filler neck extension	
				7076	Oil filler cap	
				7286	Pin, locating hydraulic cylinders	
					Assembly Transom Plate, with 5, 6, 22,	
					23, 45, 69, 70, 71, 72, comprising:-	
					Transom Plate	
	75	S1	130H 130 Non swivel	~ 7008	Gasket, "Z-DRIVE" to transom	
SWIVEL FORK ASSEMBLY						
	76	-- C1	130	37378571	Fork, swivel	
	77	S2		32716123	Pin, pivot - locating catch	
	78	S1		36671134	Catch, swivel fork locating	
	79	S2		2221281	Socket screw, retaining pin to fork	
	80	S1		31751111	Spring, swivel fork to catch	
	81	S1	130H	7005	Fork, swivel	
	82	S1		7007	Shaft hyd cylinder pivot	
	83	S4		33117417	Washer, plain cylinder to shaft	Stainless steel
	84	S2		7010	Washer, nylon cylinder to shaft	
	85	S2		2727177	Circlip, cylinder to shaft	
	86	S1	All Models	32716121	Pin, centre-fork to body	
	87	S2		33813312	Washer, thrust - to body	
	88	S2		32716119	Pin, fork upper	
	89	S4	130	~ 2221285	Socket screw retaining pins	
	89	S3	130H	2221285	Socket screw retaining pins	
HYDRAULIC TRIM/TILT						
	-	-1	130H	9003	Assembly, comprising:-	
	91	S2		7100	Nut	
	92	S2		7099	Washer	
	93	S4		7103	Elbow stem	
	94	S8 +		7105	Nut - tubing	
	95	S8 +		7104	Sleeve - tubing	
	96	S To suit		7217	Hose	
	97	S1		7219	Motor pump	
	98	S3		7216	Tee	
		1		9008	Gauge kit with items 92, 93, 96	
	99	S1		7218	Gauge	
	100	S1		7166	Reducer	
	101	S To suit		7163	Hose	
	102	S2		7165	Nut	
	103	S2		7164	Sleeve	
	104	S1		7162	Adaptor	
	105	S1		7214	Clamp motor pump	
	106	S1		7213	Relay bank	
	107	S1		7215	Switch - and shroud	

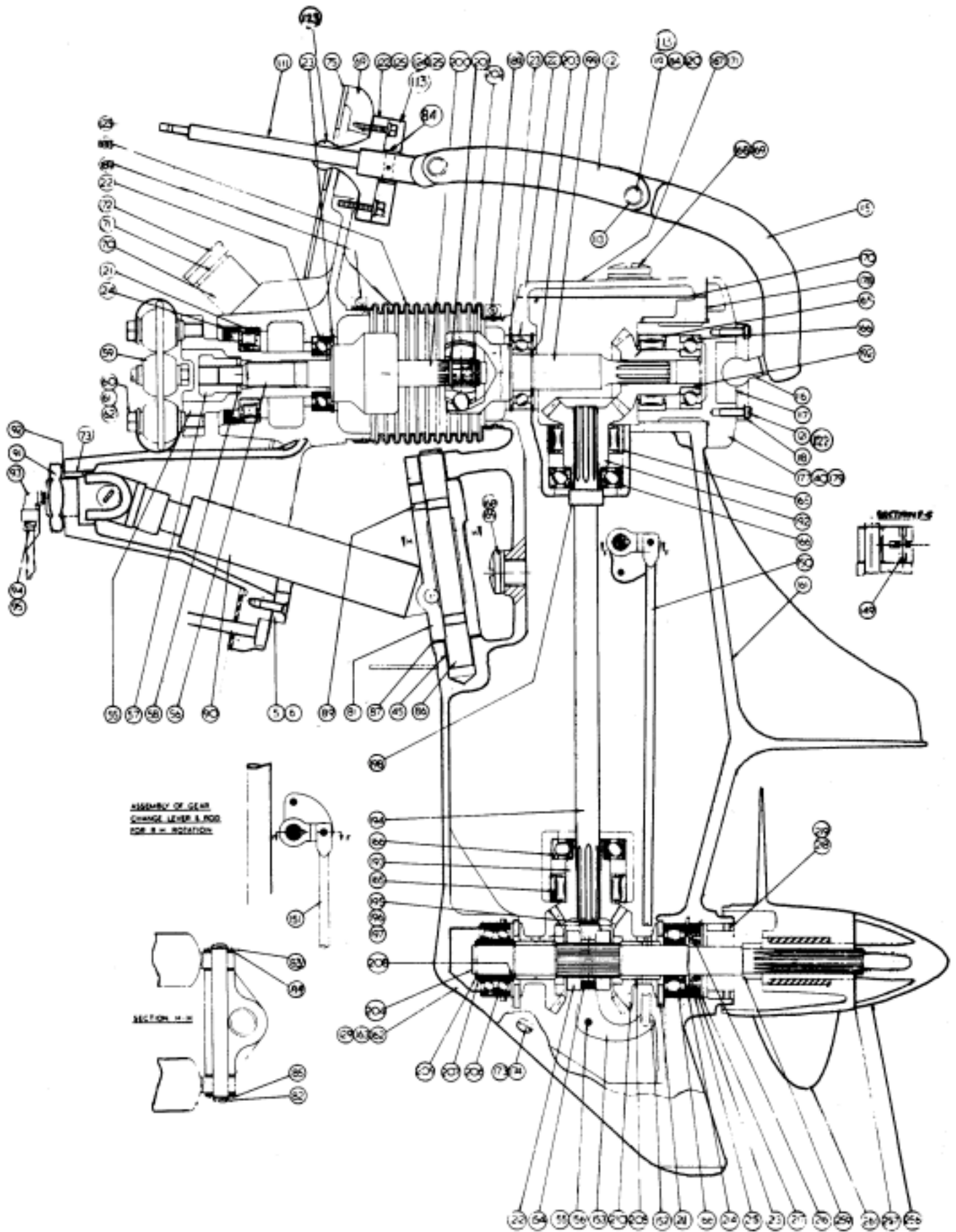
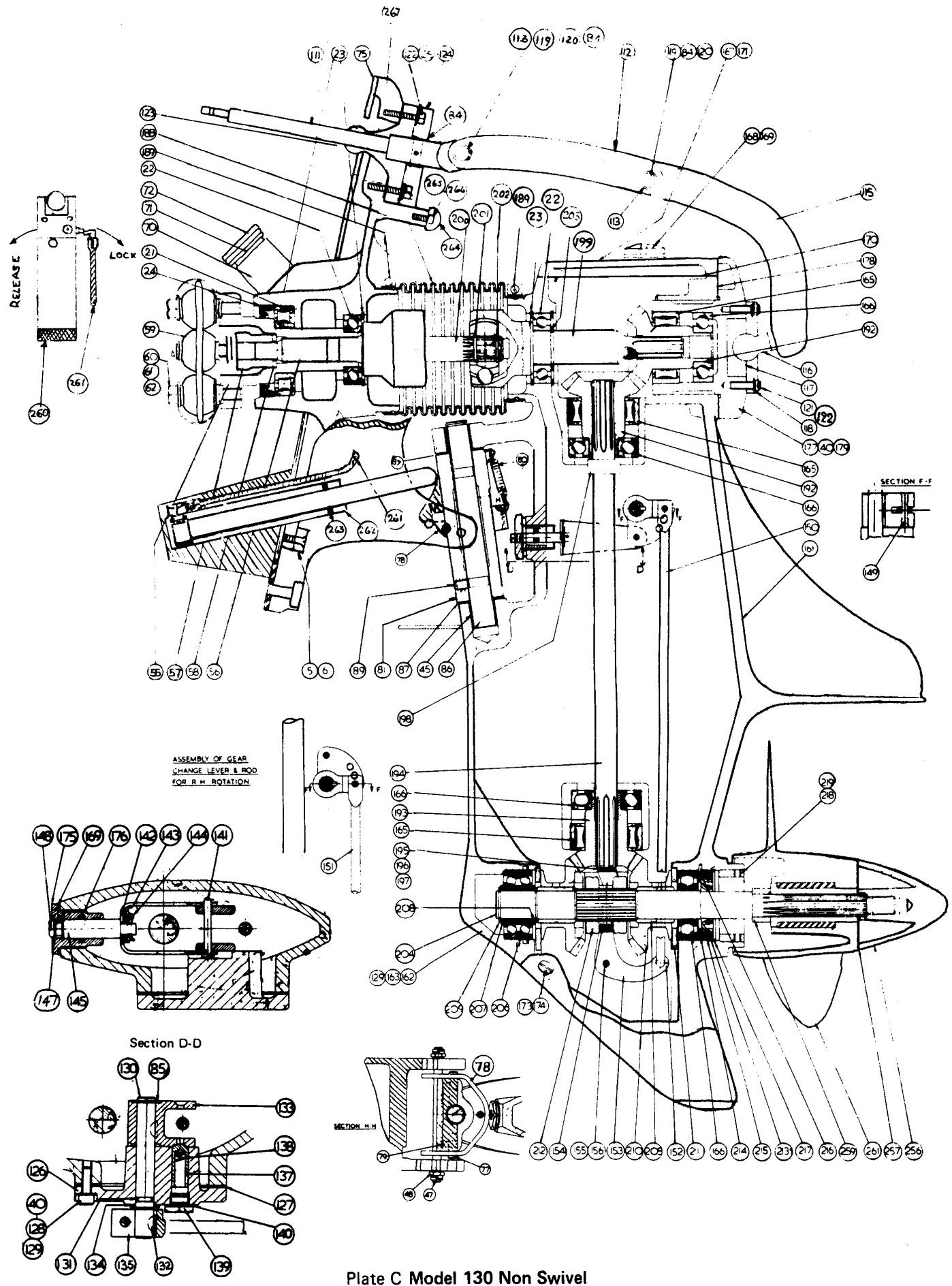

Plate B Model 130H Assy.

Ref. No.	S ^o r NS	Qty. Req.	For NS Modet	Part N ^o ,	Description	Remarks
108	S	7		7167	HYDRAULIC TRIM/TILT (eontd)	
109	S	2		7161	Terminal	
110	S	2		7291	Connector - bullet Terminal - bullet	
111	S	1		7242	STEERING LINKAGE	
112	NS	1	130/ 130H	7225	Assembly steering arm and tee link	
113	S	6		7067	Assembly link and bushes comprising:-	
115	S	1		2513906	Link steering, upper	
116	S	1		37374601	Bush steering, upper link	
117	S	1		32762115	Link steering - lower	
118	S	1		32813107	Ball, lower steering link	
119	S	3		33825111	Cup, inner - steering ball joint	
84	S	6		32716125	Cap, outer - steering ball joint	
120	S	3		7010	Pin - upper link to steering arm & lower link to steering arm	
121	S	4		2222712	Washer - upper link to steering arm & lower link to steering arm and tee link	
122	S	8		2221281	Socket screw - upper link to steering arm and lower link	
123 ~	S	1		33825426	Screw, linkage to bevel gear housing	
124	S	1		7238	Washer hsg retaining	
125	S	4		7335	Gaiter, steering arm to transom	
126	S	1		37421511	Housing steering arm pivot	
126A ~	S	1		or 37421512	Set screw steering hsg retaining	
127	S	1		36822517	Gear change linkage	
40	S	6		2222712	Bearing, gear change, L.H.	Stainless steel
129	S	6		33111411	Bearing, lever shaft, R.H.	Stainless steel
130	S	1		32732113	Gasket, bearing to body	
131	S	1		0730135	Socket screw bearing to body .	
132	S	2		0500003	Washer, plain - bearing to body	
85	S	2		2727177	Shaft, gear change lever	
133	S	1		37376481	'O' Ring, sealing shaft	
134	S	1		33812114	Key, gear change shaft	
135	S	1		37366641	Circlip, retaining	
136	S	1		2222712	Lever, operating gear change & astern lock	
137	S	1		32455506	Washer, thrust	
138	S	1		31742126	Lever, operating	
139	S	1		32168104	Socket screw, clamping	
140	S	1		33812113	Plunger, locking gear change	
141	S	1	130	32711408	Spring, locking gear change	
142	S	1		36512111	Plug retaining spring gear change	
143	S	1		33114411	Washer plug sealing	
144	S	1		0610016	Pin, astern lock form to lever	
145	S	1	130 only	32724105	Fork to astern lock pin	
147	S	3	As req.	33111411	Washer, astern lock pin operating	
148	S	1		32148311	Split pin, astern lock pin to fork	
149	S	1	130/ 130H	32114125	Pin astern lock	
150	S	1		34161109	Washer	
151	S	1		or 34161111	Screw adjusting	
152	S	1		0610002	Pin - gear change rod to lever	
153	S	1		7280	Rod, gear change operating - L.H. Rotation	
154	S	1		37378551	Rod, gear change operating - R.H. Rotation	
155	S	1		32182112	Split pin rod to lever	
156	S	1		33811111	Lever, bell crank clutch operating	
122	S	1	NOTE PARTS 1	41476002	Yoke operating dog clutch	
124	S	1		33823113	Pin, pivot - bell crank lever	
					Washer, sealing - pin to body	
					AVAILABLE FOR OLD TYPE STEERING	
					Nylon cup steer arm to transom plate	
					1	
					1	
					1	
					Nylon cap steering arm to cup	

Ref. No.	S or NS	Qty. Req.	For NS Model	Part No.	Description	Remarks
161	S	1	130/	710954	ASSEMBLY BODY, SKEG & GEARS, etc.	Stainless steel Stainless steel
162	S	1	130H	0999999	Assembly body and bearings, comprising:-	
163	NS	1		37522491	Assembly body comprising:-	
129	NS	1		37171751	Body, drive	
45	S	10		2222256	Skeg	
165	S	10		33111411	Socket screw, skeg to body	
22	S	2		2513911	Washer, plain	
23	S	2		7222	Bush, centre pin swivel fork	
166	S	2		0040005	Bearing, roller-gear, vertical shaft	
169	S	1		00040020	Bearing, ball-gear, vertical shaft	
176	S	2		2721790	Bearing, ball - C.V. joint - rear	
167	S	1	All Model	37532891	Circlip, locating ball bearing	
168	S	1		32168105	Cover top	Stainless steel
169	S	1		0920351	Plug, oil filler - top cover	
170	S	1		36857407	Washer, plug oil filler to cover	
171	S	8		2222712	Gasket, top cover to body	
172	S	1		32168104	Screw top cover to body	
140	S	1		33812113	Plug, oil level	
173	S	1		32158105	Washer, plug foil level) to body	
174	S	1		33812112	Plug, oil drain (skeg)	
175	S	1	130 only	33533114	Washer, plug oil drain to skeg	
169	S	1		0920351	Bush, astern lock pin	
176	S	1		2415710	Washer, sealing bush to body	
168	S	1	130H/	32168105	'O' ring, sealing astern lock pin	
177	S	1	130/	710948	Plug - blanking	Stainless steel Stainless steel
165	S	1	130H	37446221	Assembly housing top bevel gear comprising:-	
166	S	1		7222	Housing, top vevel gear	
178	S	2 or to suit		0040005	Bearing, roller	
40	S	6		36861724	Bearing, ball	
179	S	6		2222256	Gasket Housing top bevel gear to body	
183	S	1	130/ 130 H	33111411	Socket screw Housing top bevel gear to body	
183	S	1	130/ 130 H	37584125	Washer plain Housing top bevel gear to body	
183	S	1	130/ 130 H	37584125	Splash plate	
185	S	2	All	33134428	Distance piece, splash plate to body	Not used on Z. drives from serial number 2ZE04891
186	S	2	Models	2227285	Setscrew (rear) splash plate to body	
187	S	2		2227283	Setscrew (front) splash plate to body	

Ref. No.	S or NS	Qty. Req.	For NS Model	Part No.	Description	Remarks
					ASSEMBLY BODY, SKEG & GEARS, etc. (contd..)	
188	S	1	130/	33884112	Gaiter - C.V. Joint cover	
189	S	2	130H	7002	Clip, sealing gaiter	
					GEARS AND SHAFTS - BODY	
192	S	2	130/ 130H	31174141	Bevel gear top (1 in body and 1 in rear bearing housing)	
193	S	1		31174132	Bevel gear - lower	
194	S	1		32462114	Shaft - vertical drive	
195	S	1		36612118	Retainer - vertical drive	
196	S	2		0748352	Screw - retainer to body	
197	S	2		0920052	Washer - retainer to body	
198	S	1		33177512	Collar - locating vertical shaft	
	S	1		710911	Assembly C.V. joint (rear) and intermediate shaft, comprising:-	
199	S	t		2584602	C.V. joint (rear)	
200	S	1		33451522	Shaft intermediate	
201	S	t		2724459	Circlip retaining, shaft to C.V. joint	
202	S	1		2725191	Circlip retaining, shaft to C.V. joint	
203	S	1		2724410	Circlip - C.V. joint to bearing	
					Assembly propeller shaft	
204	S	1		32767422	Shaft propeller	
205	S	2		33431405	Bush, propeller shaft	
206	S	1		7147	Bearing, double row ball	
207	S	1		33123118	Spacer bearing to shaft	
208	S	1		7146	Spacer bearing to shaft	
209	S	2		2724322	Circlip bearing to shaft	
210	S	2		31174152	Bevel gear - propeller shaft	
211	S	As Reqd.		31138101	Thrust washer (0.0279/0.282) bevel gear	
	S	As Reqd.		31138102	Thrust washer (0.292/0.295) bevel gear	
	S	As Reqd.		31138103	Thrust washer (0.285/0.288) bevel gear	
212	S	1		33571122	Dog clutch, propeller shaft	
166	S	1		0040005	Bearing, ball propeller shaft	
213	S	2		2415520	Oil seal propeller shaft	
214	S	1		33411503	Housing, oil seal propeller shaft	
215	S	1		2415817	'O' ring sealing housing propeller shaft	
216	S	1		2116024	Pin, locating housing	
217	S	1		31736114	Circlip, retaining oil seal housing	
218	S	1		33131507	Ring (zinc)	
219	S	2		2221281	Socket screw	
260	S	1		7389	Hydraulic hand pump	Complete onl
261	S	1		7386	Hydraulic hose and end fittings	
262	S	1		7392	Hydraulic cylinder	Complete onl
263	S	1		7383	'O' ring cylinder to piston sealing	
264	S	1		7380	Leg kickup bump stop	
265	S	2		2222712	Socket screw bump stop retaining	
266	S	2		33111411	Washer to socket screw	
267	S	1		7362	Non swivel transom plate	



ASSEMBLY OF GEAR
CHANGE LEVER & ROD
FOR R.H. ROTATION

Section D-D

Section C-C

SECTION H-H

SECTION F-F

Plate C Model 130 Non Swivel

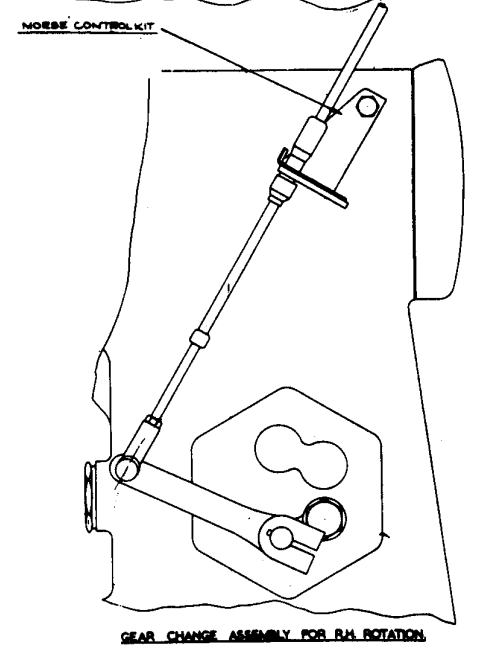
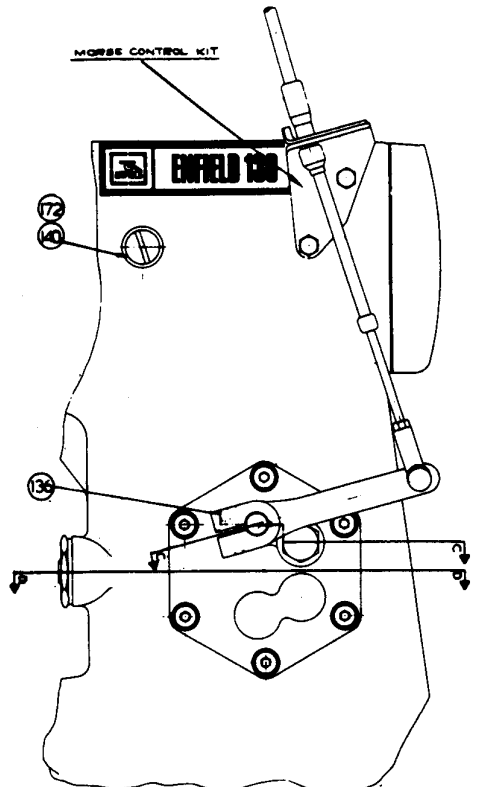
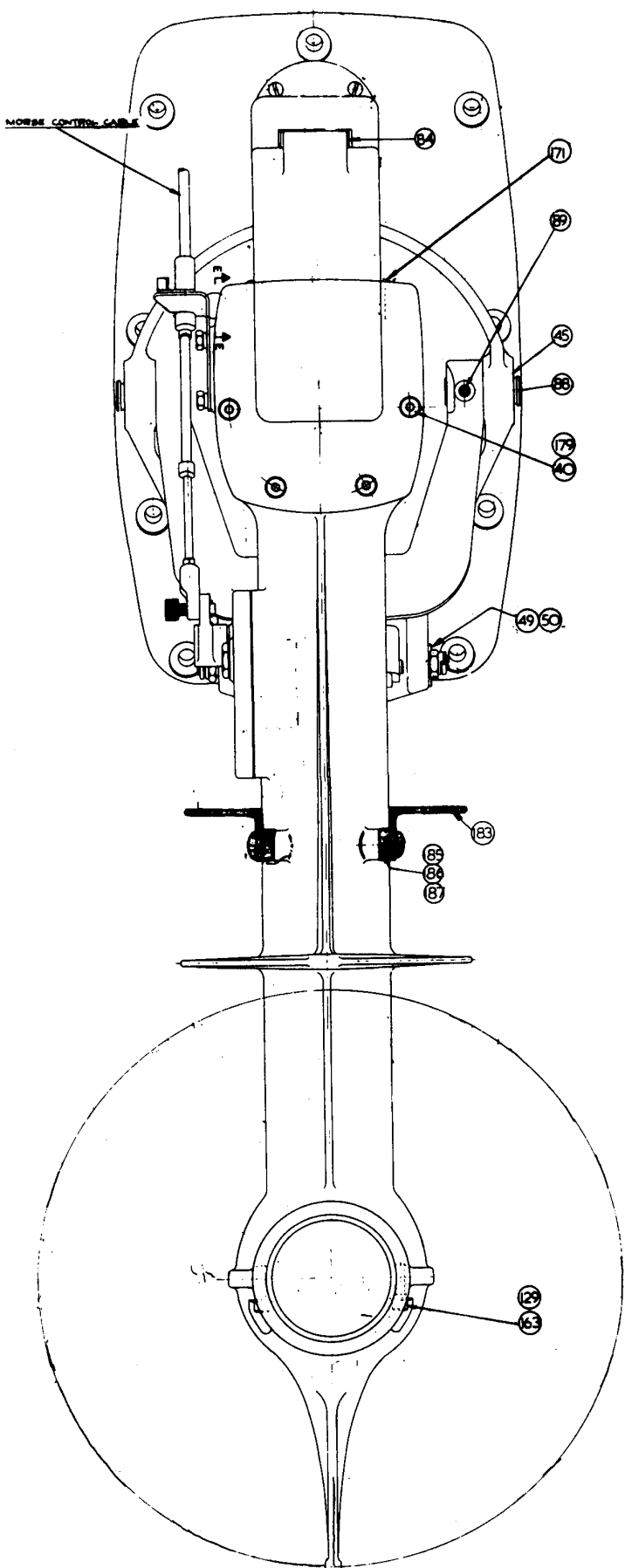

Ref. No.	S or NS	Qty. Req	For NS Model	Part No.	Description	Remarks
245	S	1	130	7114	Instruction - Transfer (top link)	
246	S	1		7125	Motif - Port (Body)	
247	S	1		7126	Motif - Starboard (Body)	
248	S	1	130H	7114	Instruction - Transfer (Top link)	
249	S	1		7115	Motif - Port (Body)	
250	S	1		7116	Motif -Starboard (Body)	

"Z-DRIVE" TRANSOM UNIT ACCESSORIES AND SERVICE PARTS

Attachment of "Z-DRIVE" Transom Unit to Boat Transom.

GASKET SETS

Coupling "Z-DRIVE" Transom Unit to engine. To suit various installation requirements, close and distance coupling arrangements are available as follows:

130 and 1ØH recommended engine coupling components:

8101	Stub shaft (short)	Part machined
7130	Stub shaft (long)	undrilled. Customer to finish to suit engine.
	1130 H)	

37463734	Coupling, half
2581215	Coupling, flexible
0096637	Bolt, flexible coupling to half coupling - 2 off
0576101	Nut, flexible coupling to half coupling - 2 off

Close Coupling.-

8009	Close coupling kit comprising:
36133118	Distance piece
0096642	Bolt Flexible coupling, distance piece to
0576101	Nut "Z-DRIVE" coupling, 2 off

REMOTE CONTROLS - SINGLE LEVER (MORSE):- be ordered from MORSE CONTROL LIMITED Distributors.

Each unit will require a Single Lever Remote Control Box, a Pair of Cables of predetermined lengths, a Gear Change Connection Kit to match the direction of propeller rotation and a Throttle Connection Kit to suit the type of engine employed.

All models
8089
SEAL SET

130

8090	Seal Set comprising:-
245821	Ring
33824117	'O' Ring
2415507	Oil seal input
2415520	Oil seal propeller shaft
2415817	'O' Ring, housing oil seal propeller shaft
0730135	'O' Ring sealing shaft gear change
2415710	'O' Ring sealing astern lock pin
2415943	Washer, sealing housing astern lock
2415702	'O' Ring, sealing plunger swivel plate stop

130H Comprising:-

2415507
2415520
2415817
0730135

LOCKING ARRANGEMENT - SWIVELLING GEAR

The plunger release cable, fitted within the craft, allows for remote operation of the swivel plate locking plunger when cranking the unit into or out of its Port and Starboard parking positions.

8096	Plunger release cable assembly 8 ft. (2.4m)
comprises:	
41718422	Cable assembly, swivel plate locking plunger release
36562118	Bracket, plunger release cable support

Ref. No.	Part Number	Description	Model
256	7112	Spinner Nut	130/130H
257	33177511	Tabwasher	130/130H
259	33144114	Distance Piece	130/130H

Reference 261

Part Number	Description	Part Number
Left Hand Rotation		Right Hand Rotation
8005	Propeller Assembly - 11 1/2" (292mm) dia. X 11" (279mm) pitch X 3 blade	8004
8003	11 1/2" (292mm) dia. X 12" (305mm) pitch X 3 "	8002
8006	12 1/2" (318mm) dia. X 11" (279mm) pitch X 3 "	' 8005
8056	" 12/a" (318mm) dia. X 12" (305mm) pitch X 3 "	8057
8058	12/z" (318mm1 dia. X 13" (330mm) pitch X 3 "	8059
8060	" 12/x" (318mm) dia. X 14" (356mm) pitch X 3 "	8061
8062	" 12 1/2 (318mm) dia. X 15" 1381mm) pitch X 3 "	' 8063
8064	13" (330mm) dia. X 8" (203mm) pitch X 3 "	' 8065
8100	" 13" (330mm1 dia. X 9" (229mm) Pitch X 3 "	8066
8067	13" (330mm1 dia. X 10" 1254mm1 pitch X 3 "	' 8068
8073	14" (356mm) dia. X 9" (229mm) pitch X 3 "	8074
8075	14" (356mm) dia. X 10" (245mm) pitch X 3 "	8076
8077	14" (356mm) dia. X 11" (279mm) pitch X 3 "	8078
8079	14" (356mm) dia. X 12" (305mm) pitch X 3 "	8080
8081	14" (356mm) dia. X 13" (330mm) pitch X 3 "	8082
8083	14" (356mm) dia. X 14" 1356mm) pitch X 3 "	8084
8085	14" (356mm) dia. X 16" 1406mm) pitch X 3 "	8086