

# Service Manual



## TLA 714 Color Portable Mainframe 071-0267-01

### **Warning**

The servicing instructions are for use by qualified personnel only. To avoid personal injury, do not perform any servicing unless you are qualified to do so. Refer to all safety summaries prior to performing service.



Copyright © Tektronix, Inc. All rights reserved. Licensed software products are owned by Tektronix or its suppliers and are protected by United States copyright laws and international treaty provisions.

Use, duplication, or disclosure by the Government is subject to restrictions as set forth in subparagraph (c)(1)(ii) of the Rights in Technical Data and Computer Software clause at DFARS 252.227-7013, or subparagraphs (c)(1) and (2) of the Commercial Computer Software – Restricted Rights clause at FAR 52.227-19, as applicable.

Tektronix products are covered by U.S. and foreign patents, issued and pending. Information in this publication supercedes that in all previously published material. Specifications and price change privileges reserved.

Tektronix, Inc., 14200 SW Karl Braun Drive, Beaverton, OR 97077

TEKTRONIX and TEK are registered trademarks of Tektronix, Inc.

## HARDWARE WARRANTY

Tektronix warrants that the products that it manufactures and sells will be free from defects in materials and workmanship for a period of one (1) year from the date of shipment. If a product proves defective during this warranty period, Tektronix, at its option, either will repair the defective product without charge for parts and labor, or will provide a replacement in exchange for the defective product.

In order to obtain service under this warranty, Customer must notify Tektronix of the defect before the expiration of the warranty period and make suitable arrangements for the performance of service. Customer shall be responsible for packaging and shipping the defective product to the service center designated by Tektronix, with shipping charges prepaid. Tektronix shall pay for the return of the product to Customer if the shipment is to a location within the country in which the Tektronix service center is located. Customer shall be responsible for paying all shipping charges, duties, taxes, and any other charges for products returned to any other locations.

This warranty shall not apply to any defect, failure or damage caused by improper use or improper or inadequate maintenance and care. Tektronix shall not be obligated to furnish service under this warranty a) to repair damage resulting from attempts by personnel other than Tektronix representatives to install, repair or service the product; b) to repair damage resulting from improper use or connection to incompatible equipment; c) to repair any damage or malfunction caused by the use of non-Tektronix supplies; or d) to service a product that has been modified or integrated with other products when the effect of such modification or integration increases the time or difficulty of servicing the product.

**THIS WARRANTY IS GIVEN BY TEKTRONIX IN LIEU OF ANY OTHER WARRANTIES, EXPRESS OR IMPLIED. TEKTRONIX AND ITS VENDORS DISCLAIM ANY IMPLIED WARRANTIES OF MERCHANTABILITY OR FITNESS FOR A PARTICULAR PURPOSE. TEKTRONIX' RESPONSIBILITY TO REPAIR OR REPLACE DEFECTIVE PRODUCTS IS THE SOLE AND EXCLUSIVE REMEDY PROVIDED TO THE CUSTOMER FOR BREACH OF THIS WARRANTY. TEKTRONIX AND ITS VENDORS WILL NOT BE LIABLE FOR ANY INDIRECT, SPECIAL, INCIDENTAL, OR CONSEQUENTIAL DAMAGES IRRESPECTIVE OF WHETHER TEKTRONIX OR THE VENDOR HAS ADVANCE NOTICE OF THE POSSIBILITY OF SUCH DAMAGES.**

## SOFTWARE WARRANTY

Tektronix warrants that the media on which this software product is furnished and the encoding of the programs on the media will be free from defects in materials and workmanship for a period of three (3) months from the date of shipment. If a medium or encoding proves defective during the warranty period, Tektronix will provide a replacement in exchange for the defective medium. Except as to the media on which this software product is furnished, this software product is provided "as is" without warranty of any kind, either express or implied. Tektronix does not warrant that the functions contained in this software product will meet Customer's requirements or that the operation of the programs will be uninterrupted or error-free.

In order to obtain service under this warranty, Customer must notify Tektronix of the defect before the expiration of the warranty period. If Tektronix is unable to provide a replacement that is free from defects in materials and workmanship within a reasonable time thereafter, Customer may terminate the license for this software product and return this software product and any associated materials for credit or refund.

**THIS WARRANTY IS GIVEN BY TEKTRONIX IN LIEU OF ANY OTHER WARRANTIES, EXPRESS OR IMPLIED. TEKTRONIX AND ITS VENDORS DISCLAIM ANY IMPLIED WARRANTIES OF MERCHANTABILITY OR FITNESS FOR A PARTICULAR PURPOSE. TEKTRONIX' RESPONSIBILITY TO REPLACE DEFECTIVE MEDIA OR REFUND CUSTOMER'S PAYMENT IS THE SOLE AND EXCLUSIVE REMEDY PROVIDED TO THE CUSTOMER FOR BREACH OF THIS WARRANTY. TEKTRONIX AND ITS VENDORS WILL NOT BE LIABLE FOR ANY INDIRECT, SPECIAL, INCIDENTAL, OR CONSEQUENTIAL DAMAGES IRRESPECTIVE OF WHETHER TEKTRONIX OR THE VENDOR HAS ADVANCE NOTICE OF THE POSSIBILITY OF SUCH DAMAGES.**

# Table of Contents

<b>General Safety Summary</b> .....	<b>vii</b>
<b>Service Safety Summary</b> .....	<b>ix</b>
<b>Preface</b> .....	<b>xi</b>
Manual Structure .....	xi
Manual Conventions .....	xi
Contacting Tektronix .....	xii
<b>Introduction</b> .....	<b>xiii</b>
Adjustment and Certification Interval .....	xiii
Strategy for Servicing .....	xiii
Service Offerings .....	xiv
 <b>Specifications</b>	
Product Description .....	1-1
Characteristics Tables .....	1-2
 <b>Operating Information</b>	
Installation .....	2-1
I/O and Memory Hardware .....	2-1
Operating System and Application Interface .....	2-6
Diagnostics .....	2-6
 <b>Theory of Operation</b>	
Portable Mainframe .....	3-1
 <b>Maintenance</b>	
Preparation .....	4-1
Preventing ESD .....	4-1
Inspection and Cleaning .....	4-2
<b>Removal and Installation Procedures</b> .....	<b>4-5</b>
Preparation .....	4-5
General Instructions .....	4-5
Equipment Required .....	4-6
Exploded View .....	4-7
Removing the Replaceable Hard Disk Drive .....	4-8
Removing the Hard Disk Drive From The Cartridge .....	4-10
Trim Ring .....	4-10
Flat Panel Display Assembly .....	4-12
Floppy Disk Drive .....	4-14
Front Panel Interface Board .....	4-14
Front Panel Control Assembly .....	4-15
Front Panel Knobs .....	4-17
CD ROM Drive .....	4-18
Bottom Cover .....	4-19

Top Cover . . . . .	4-20
Left Side Cover . . . . .	4-21
Right Side Cover . . . . .	4-22
Line Cord and Line Fuse . . . . .	4-23
Power Supply . . . . .	4-25
Rear Chassis Fan Tray . . . . .	4-26
Individual Fans . . . . .	4-28
Flip Stands and Rear Feet . . . . .	4-30
Cord Wrap Feet . . . . .	4-31
Handle . . . . .	4-32
Procedures for Internal Parts . . . . .	4-33
Controller Board . . . . .	4-33
Main Memory . . . . .	4-35
Backplane Board . . . . .	4-36
Front Panel Control Board . . . . .	4-36
Glidepoint Assembly . . . . .	4-38
Elastomeric Keypad . . . . .	4-39
<b>Fixed Hard Disk Drive Removal and Installation . . . . .</b>	<b>4-41</b>
Preparation . . . . .	4-42
General Instructions . . . . .	4-42
Tools Required . . . . .	4-42
Remove Hard Disk Drive From The Cartridge . . . . .	4-43
Removing the Replaceable Hard Disk Drive . . . . .	4-44
Remove the Trim Ring . . . . .	4-46
Remove Flat Panel Display Assembly . . . . .	4-47
Install Fixed Hard Disk Drive . . . . .	4-49
Install Flat Panel Display Assembly . . . . .	4-51
Install the Trim Ring . . . . .	4-51
Verify Operation . . . . .	4-51
<b>Troubleshooting . . . . .</b>	<b>4-53</b>
Service Level . . . . .	4-53
Check for Common Problems . . . . .	4-54
Eliminate Other Problem Sources . . . . .	4-56
Troubleshoot the Portable Mainframe . . . . .	4-56
Equipment Required . . . . .	4-56
Fault Isolation Procedure . . . . .	4-56
Controller and PC Diagnostics . . . . .	4-58
Power-On Diagnostics . . . . .	4-58
QA+Win32 . . . . .	4-59
Bypassing Front Panel Controls . . . . .	4-60
Checking the Power Supply Voltages . . . . .	4-60
Isolating System Problems . . . . .	4-62
BIOS Setup Error Messages . . . . .	4-65
Update the BIOS Version . . . . .	4-67
Adjustment After Repair . . . . .	4-68
TLA 700 Startup Sequence . . . . .	4-68
<b>Repackaging Instructions . . . . .</b>	<b>4-71</b>
Packaging . . . . .	4-71
Shipping to the Service Center . . . . .	4-71

## Options

Tektronix Options .....	5-1
Service Options .....	5-2
Power Cord Identification .....	5-3

## Diagrams .

Interconnection Block Diagram .....	6-1
-------------------------------------	-----

## Replaceable Mechanical Parts

Standard Accessories .....	7-1
Optional Accessories .....	7-2
Parts Ordering Information .....	7-2
Using the Replaceable Parts List .....	7-3

## Index

# List of Figures

Figure 1–1: Front and side views of the portable mainframe .....	1–10
Figure 2–1: TLA 714 portable mainframe front panel .....	2–1
Figure 2–2: Portable mainframe rear panel .....	2–3
Figure 4–1: External parts .....	4–7
Figure 4–2: Depress the latch .....	4–8
Figure 4–3: Unlatching the hard disk drive cartridge .....	4–9
Figure 4–4: Removing the hard disk drive cartridge .....	4–9
Figure 4–5: Removing the hard disk drive from the cartridge .....	4–10
Figure 4–6: Trim ring removal .....	4–11
Figure 4–7: Flat panel display assembly removal .....	4–13
Figure 4–8: Front-panel control assembly removal .....	4–16
Figure 4–9: Top and side cover removal .....	4–21
Figure 4–10: Line cord and line fuse removal .....	4–24
Figure 4–11: Power supply removal .....	4–25
Figure 4–12: Rear chassis fan tray removal .....	4–27
Figure 4–13: Individual fan removal .....	4–29
Figure 4–14: Flip stand and rear feet removal .....	4–30
Figure 4–15: Cord-wrap feet removal .....	4–31
Figure 4–16: Handle removal .....	4–32
Figure 4–17: Internal parts .....	4–34
Figure 4–18: Front panel control assembly parts locations .....	4–37
Figure 4–19: Removing the hard disk drive from the cartridge .....	4–43
Figure 4–20: Depress the latch .....	4–44
Figure 4–21: Unlatching the hard disk drive cartridge .....	4–45
Figure 4–22: Removing the hard disk drive cartridge .....	4–45
Figure 4–23: Front cover and trim ring removal .....	4–46
Figure 4–24: Flat panel display assembly removal .....	4–48
Figure 4–25: Installing the fixed hard disk drive .....	4–50
Figure 4–26: Primary troubleshooting tree .....	4–57
Figure 4–27: Jumper locations for bypassing front panel control assembly .....	4–60
Figure 4–28: Location of J1 and J2 pins within the portable mainframe .....	4–62
Figure 4–29: ResMan32 program output .....	4–64



---

<b>Figure 4-30: TLA 700 startup sequence</b> .....	<b>4-69</b>
<b>Figure 6-1: Portable mainframe interconnection diagram</b> .....	<b>6-1</b>
<b>Figure 6-2: Portable mainframe block diagram</b> .....	<b>6-2</b>
<b>Figure 7-1: External parts</b> .....	<b>7-9</b>
<b>Figure 7-2: Front panel assembly</b> .....	<b>7-11</b>
<b>Figure 7-3: Floppy disk drive, front panel interface board, and related cables</b> .....	<b>7-13</b>
<b>Figure 7-4: Controller board and EMI shield</b> .....	<b>7-15</b>
<b>Figure 7-5: Power supply and fan</b> .....	<b>7-17</b>

## List of Tables

<b>Table 1–1: Internal controller</b> .....	<b>1–2</b>
<b>Table 1–2: Display system</b> .....	<b>1–3</b>
<b>Table 1–3: Backplane interface</b> .....	<b>1–4</b>
<b>Table 1–4: Front panel interface</b> .....	<b>1–4</b>
<b>Table 1–5: Rear panel interface</b> .....	<b>1–5</b>
<b>Table 1–6: AC power source</b> .....	<b>1–7</b>
<b>Table 1–7: Secondary power</b> .....	<b>1–7</b>
<b>Table 1–8: Certifications and compliances: TLA 714 Logic Analyzer Color Portable Mainframe</b> .....	<b>1–8</b>
<b>Table 1–9: Cooling</b> .....	<b>1–9</b>
<b>Table 1–10: Environmental</b> .....	<b>1–9</b>
<b>Table 1–11: Mechanical</b> .....	<b>1–10</b>
<b>Table 2–1: USB (universal serial bus) pin assignments</b> .....	<b>2–2</b>
<b>Table 2–2: SVGA OUT pin assignments</b> .....	<b>2–4</b>
<b>Table 2–3: LPT (parallel interface) pin assignments</b> .....	<b>2–5</b>
<b>Table 4–1: Tools required for part removal</b> .....	<b>4–6</b>
<b>Table 4–2: Failure symptoms and possible causes</b> .....	<b>4–54</b>
<b>Table 4–3: TLA 700 Power-on diagnostic tests</b> .....	<b>4–58</b>
<b>Table 4–4: Power supply voltages and backplane connector pins</b> ...	<b>4–61</b>
<b>Table 4–5: Command line options for ResMan32</b> .....	<b>4–63</b>
<b>Table 4–6: BIOS error codes and explanations</b> .....	<b>4–65</b>
<b>Table 5–1: Portable Mainframe options and upgrade kits</b> .....	<b>5–1</b>
<b>Table 5–2: Power cord identification</b> .....	<b>5–3</b>
<b>Table 7–1: Standard accessories</b> .....	<b>7–1</b>
<b>Table 7–2: Standard accessories</b> .....	<b>7–2</b>
<b>Table 7–3: Parts lists column descriptions</b> .....	<b>7–4</b>

# General Safety Summary

Review the following safety precautions to avoid injury and prevent damage to this product or any products connected to it. To avoid potential hazards, use this product only as specified.

*Only qualified personnel should perform service procedures.*

While using this product, you may need to access other parts of the system. Read the *General Safety Summary* in other system manuals for warnings and cautions related to operating the system.

## To Avoid Fire or Personal Injury

**Use Proper Power Cord.** Use only the power cord specified for this product and certified for the country of use.

**Connect and Disconnect Properly.** Do not connect or disconnect probes or test leads while they are connected to a voltage source.

**Ground the Product.** This product is grounded through the grounding conductor of the power cord. To avoid electric shock, the grounding conductor must be connected to earth ground. Before making connections to the input or output terminals of the product, ensure that the product is properly grounded.

**Observe All Terminal Ratings.** To avoid fire or shock hazard, observe all ratings and marking on the product. Consult the product manual for further ratings information before making connections to the product.

The common terminal is at ground potential. Do not connect the common terminal to elevated voltages.

Do not apply a potential to any terminal, including the common terminal, that exceeds the maximum rating of that terminal.

**Do Not Operate Without Covers.** Do not operate this product with covers or panels removed.

**Use Proper Fuse.** Use only the fuse type and rating specified for this product.

**Avoid Exposed Circuitry.** Do not touch exposed connections and components when power is present.

**Do Not Operate With Suspected Failures.** If you suspect there is damage to this product, have it inspected by qualified service personnel.

**Do Not Operate in Wet/Damp Conditions.**

**Do Not Operate in an Explosive Atmosphere.**

**Keep Product Surfaces Clean and Dry.**

**Provide Proper Ventilation.** Refer to the manual's installation instructions for details on installing the product so it has proper ventilation.

**Symbols and Terms**

**Terms in this Manual.** These terms may appear in this manual:



---

**WARNING.** *Warning statements identify conditions or practices that could result in injury or loss of life.*

---



---

**CAUTION.** *Caution statements identify conditions or practices that could result in damage to this product or other property.*

---

**Terms on the Product.** These terms may appear on the product:

**DANGER** indicates an injury hazard immediately accessible as you read the marking.

**WARNING** indicates an injury hazard not immediately accessible as you read the marking.

**CAUTION** indicates a hazard to property including the product.

**Symbols on the Product.** The following symbols may appear on the product:



WARNING  
High Voltage



Protective Ground  
(Earth) Terminal



CAUTION  
Refer to Manual



Double  
Insulated

# Service Safety Summary

Only qualified personnel should perform service procedures. Read this *Service Safety Summary* and the *General Safety Summary* before performing any service procedures.

**Do Not Service Alone.** Do not perform internal service or adjustments of this product unless another person capable of rendering first aid and resuscitation is present.

**Disconnect Power.** To avoid electric shock, disconnect the main power by means of the power cord or, if provided, the power switch.

**Use Care When Servicing With Power On.** Dangerous voltages or currents may exist in this product. Disconnect power, remove battery (if applicable), and disconnect test leads before removing protective panels, soldering, or replacing components.

To avoid electric shock, do not touch exposed connections.



# Preface

This is the service manual for the TLA 714 Color Portable Mainframe. Read this preface to learn how this manual is structured, what conventions it uses, and where you can find other information related to servicing this product. Read the *Introduction* following this preface for safety and other important background information needed before using this manual for servicing this product.

## Manual Structure

This manual is divided into chapters, which are made up of related subordinate topics. These topics can be cross referenced as sections.

Be sure to read the introductions to all procedures. These introductions provide important information needed to do the service correctly, safely, and efficiently.

## Manual Conventions

This manual uses certain conventions that you should become familiar with before attempting service.

### Modules

Throughout this manual, the term *module* refers to a TLA 700 Series Logic Analyzer or DSO unit that mounts inside a TLA 700 Series portable or benchtop chassis. A module is composed of circuit cards, interconnecting cables, and a user-accessible front panel.

### Replaceable Parts

This manual refers to any field-replaceable assembly or mechanical part specifically by its name or generically as a replaceable part. In general, a replaceable part is any circuit board or assembly, such as the hard disk drive, or a mechanical part, such as the I/O port connectors, that is listed in the replaceable parts list of Chapter 10. Also, see *Strategy for Servicing* on page xiii.

### Safety

Symbols and terms related to safety appear in the *Service Safety Summary* found at the beginning of this manual.

## Contacting Tektronix

Product Support	<p>For questions about using Tektronix measurement products, call toll free in North America: 1-800-TEK-WIDE (1-800-835-9433 ext. 2400) 6:00 a.m. – 5:00 p.m. Pacific time</p> <p>Or contact us by e-mail: tm_app_supp@tek.com</p> <p>For product support outside of North America, contact your local Tektronix distributor or sales office.</p>
Service Support	<p>Tektronix offers extended warranty and calibration programs as options on many products. Contact your local Tektronix distributor or sales office.</p> <p>For a listing of worldwide service centers, visit our web site.</p>
For other information	<p>In North America: 1-800-TEK-WIDE (1-800-835-9433) An operator will direct your call.</p>
To write us	<p>Tektronix, Inc. 14200 SW Karl Braun Drive Beaverton, OR 97077 USA</p>
Website	<p>Tektronix.com</p>



# Introduction

This manual contains information needed to properly service the portable mainframe. This introduction contains information critical to safe and effective servicing.

To prevent personal injury or damage to the portable mainframe, consider the following requirements before attempting service:

- Read the *General Safety Summary* and *Service Safety Summary* found at the beginning of this manual.
- The procedures in this manual may only be performed by a qualified service person.
- Read the *Preface* beginning on page xi.
- Read *Operating Information* beginning on page 2–1.

Be sure to follow all warnings, cautions and notes.

## Adjustment and Certification Interval

Generally, you should perform the adjustments and certification (calibration) described in the *TLA 700 Series Performance Verification and Adjustment Technical Reference Manual* once per year, or following repairs that affect adjustment or calibration.

## Strategy for Servicing

This manual supports and contains information needed for periodic maintenance of the portable mainframe.

This manual supports and contains information for corrective maintenance of this product:

- supports isolation of faults to the failed circuit board or assembly level shown in the replaceable parts list of Chapter 10
- supports removal and replacement of those boards or assemblies
- supports removal and replacement of the fuse, knobs, chassis, and other mechanical parts listed in the replaceable parts list

This manual does not support component-level fault isolation and replacement.

## Service Offerings

Tektronix provides service to cover repair under warranty as well as other services that are designed to meet your specific service needs.

Whether providing warranty repair service or any of the other services listed below, Tektronix service technicians are equipped to service the portable mainframe. Services are provided at Tektronix Services Centers and on-site at your facility, depending on your location.

### Warranty Repair Service

Tektronix warrants this product for one year from date of purchase. The warranty is located behind the title page in this manual. Tektronix technicians provide warranty service at most Tektronix service locations worldwide. The Tektronix product catalog lists all service locations worldwide, or you can visit us on our *Customer Services World Center* web site at:

[Tektronix.com/Measurement/Service](http://Tektronix.com/Measurement/Service)

### Calibration and Repair Service

In addition to warranty repair, Tektronix Service offers calibration and other services which provide solutions to your service needs and quality standards compliance requirements.

The following services can be tailored to fit your requirements for calibration and/or repair of your portable mainframe.

**Service Options.** Tektronix Service Options can be selected at the time you purchase your instrument. You select these options to provide the services that best meet your service needs. These service options are listed on the *Tektronix Service Options* page following the title page of this manual.

**Service Agreements.** If service options are not added to the instrument purchase, then service agreements are available on an annual basis to provide calibration services or post-warranty repair coverage. Service agreements may be customized to meet special turn-around time and/or on-site requirements.

**Service on Demand.** Tektronix offers calibration and repair services on a “per-incident” basis that is available with standard prices.

**Self Service.** Tektronix supports repair to the replaceable-part level by providing for circuit board exchange.

Use this service to reduce down-time for repair by exchanging circuit boards for remanufactured ones. Tektronix ships updated and tested exchange boards. Each board comes with a 90-day service warranty.

**For More Information.** Contact your local Tektronix service center or sales engineer for more information on any of the Calibration and Repair Services just described.



# Specifications



# Specifications

This chapter provides a brief product description and lists the warranted characteristics, nominal traits, and typical characteristics of the portable mainframe.

## Product Description

The portable mainframe is the base component of a customer-configurable portable instrument. It can function as a logic analyzer, a digital storage oscilloscope, or both, depending on the module cards installed in its slots. The portable mainframe has the following features:

- Microsoft Windows operating system
- Standard PC I/O ports, two PCMCIA PC card slots, two USB ports, and a PC-based 266 MHz Intel Pentium with MMX processor architecture that provides automatic connectivity to numerous off-the-shelf I/O devices (Ethernet, modem, printers, etc.)
- Display system provides internal color flat-panel LCD display and an external SVGA port capable of driving large, high-resolution external monitors
- Four backplane slots provide compatibility with TLA 700 Series instrument modules
- Precision clock, bus trigger line, and event signaling between the mainframe and instrument modules supports real-time triggering, sequencing, and time correlation of events
- Mainframe compatible with international power standards, certified to international safety and EMC requirements, and tested to rugged environmental standards

## Characteristics Tables

This section lists only the specifications that are useful for servicing. All specifications listed here should be considered “typical”. Typical characteristics describe typical or average performance and provide useful reference information.

Refer to Appendix A of the *TLA 700 Series Logic Analyzer User Manual* for a complete listing of all specifications.

**Table 1–1: Internal controller**

Characteristic	Description
Operating System	Microsoft Windows 98
Microprocessor	Intel Pentium PC-AT configuration with a 266 MHz Intel Pentium MMX microprocessor
Main Memory	EDO DRAM
Style	144 pin SO DIMM, 2 Sockets
Speed	60 ns
Installed Configurations	Minimum           64 MB loaded in one socket Maximum           128 MB with both sockets loaded
Cache Memory	512 KByte Level 2 (L2) write-back cache
Flash BIOS	512 KByte
Real-Time Clock and CMOS Setups NVRAM	Real-Time clock/calendar, with typical 10-year life. Standard and advanced PC CMOS setups; see BIOS specification.
Bootable Replaceable Hard Disk Drive	Standard PC compatible IDE (Integrated device Electronics) hard disk drive residing on an EIDE interface.
Size	Minimum           2.1 GB Maximum           6.4 GB  Continually subject to change due to the fast-moving PC component environment. These storage capacities valid at product introduction.
CD ROM Drive	Standard PC compatible IDE (Integrated device Electronics) 20X (minimum) CD ROM drive residing on an IDE interface.  Continually subject to change due to the fast-moving PC component environment.
Floppy Disk Drive	Standard 3.5 inch 1.44-MB PC compatible high-density, double-sided floppy disk drive.

Table 1-2: Display system

Characteristic	Description																											
Classification	Standard PC graphics-accelerator technology capable of supporting both internal color LCD display and external color SVGA/XGA monitor																											
Display Memory Size	2 MB																											
Display Selection	<p>Hardware sense of external SVGA monitor during BIOS boot sequence; defaults to internal color LCD display; automatically switches to external SVGA monitor, if attached.</p> <p>Dual (simultaneous) display of external SVGA monitor and internal color LCD is possible via special CMOS "simulscan" setup, as long as internal and external displays operate at same resolution and display rates.</p> <p>Dynamic Display Configuration 1 support for external SVGA monitor is provided.</p>																											
External Display Drive Display Size	<p>1 SVGA/XGA-compatible analog output port</p> <table border="1"> <thead> <tr> <th><u>Resolution (Pixels)</u></th> <th><u>Colors</u></th> <th><u>DDC1?</u></th> </tr> </thead> <tbody> <tr> <td>640 x 480</td> <td>256</td> <td>yes</td> </tr> <tr> <td>640 x 480</td> <td>64,000</td> <td>yes</td> </tr> <tr> <td>640 x 480</td> <td>16,800,00</td> <td>no</td> </tr> <tr> <td>800 x 600</td> <td>256</td> <td>yes</td> </tr> <tr> <td>800 x 600</td> <td>64,000</td> <td>yes</td> </tr> <tr> <td>1024 x 768</td> <td>256</td> <td>yes</td> </tr> <tr> <td>1280 x 1024</td> <td>256</td> <td>yes</td> </tr> <tr> <td>1600 x 1200</td> <td>256</td> <td>yes</td> </tr> </tbody> </table>	<u>Resolution (Pixels)</u>	<u>Colors</u>	<u>DDC1?</u>	640 x 480	256	yes	640 x 480	64,000	yes	640 x 480	16,800,00	no	800 x 600	256	yes	800 x 600	64,000	yes	1024 x 768	256	yes	1280 x 1024	256	yes	1600 x 1200	256	yes
<u>Resolution (Pixels)</u>	<u>Colors</u>	<u>DDC1?</u>																										
640 x 480	256	yes																										
640 x 480	64,000	yes																										
640 x 480	16,800,00	no																										
800 x 600	256	yes																										
800 x 600	64,000	yes																										
1024 x 768	256	yes																										
1280 x 1024	256	yes																										
1600 x 1200	256	yes																										
Internal Display Classification	TFT (Thin Film Transistor) active-matrix color LCD display, CCFL backlight, intensity controllable via software.																											
Resolution	800 X 600																											

**Table 1–3: Backplane interface**

Characteristic	Description
Slots	4 C-size, compliant with VXIBus System Spec Rev. 1.4, except as follows:  MODID driver not capable of sinking 48 mA as required for 3-state lines (meets standard design practices for VXI); and  TTLTRG- may not be unasserted after SYSRESET-, as ADG332 does not use SYSRESET- (accommodated by local controller reset)
✓ CLK10 Frequency	10 MHz $\pm$ 100 PPM

**Table 1–4: Front panel interface**

Characteristic	Description
QWERTY Keypad	31-key ASCII keypad to support naming of files, traces, and keyboard equivalents of pointing device inputs for menus
HEX Keypad	25-key HEX keypad supporting standard DSO and LA entry functions
Special Function Knobs	
Multi-Function Knob	Various increment/decrement functions
Vertical Position	Scrolling and positioning dependent on display type
Vertical Scale	Scales waveform displays only
Horizontal Position	Scrolling and positioning dependent on display type
Horizontal Scale	Scales waveform displays only
Integrated Pointing Device	Vertically mounted glidepoint touchpad with three keypad control buttons (DRAG, SELECT, and MENU)
Dual USB Ports	Two USB complaint ports
Mouse Port	PS/2 compatible pointing device port
Keyboard Port	PS/2 compatible keyboard port



Table 1-5: Rear panel interface

Characteristic	Description
LPT (Parallel Interface) Port	36-pin high-density connector supports standard Centronics mode, Enhanced Parallel Port (EPP), or Microsoft high-speed mode (ECP)  Complies with IEEE P1284-C/D2 for bi-directional Parallel Peripheral Interface for Personal Computers (draft) style 1284-C
COM (Serial Interface) Port	9-pin male sub-D connector to support RS-232 serial port.
SVGA Output Port	15-pin sub-D SVGA connector.
Type I and II PC Card Port	Standard Type I and II PC-compatible PC card slot. Complies with PCMCIA 2.1 and JEIDA 4.1
Type III PC Card Port	Standard Type III PCMCIA-compatible PC card slot
System Trigger Input	TTL-compatible inputs via rear-panel BNC connectors
Input Destination	System trigger (TTLTRG7)
Input Levels	$V_{IH} \geq 2.0V$ ; $V_{IL} \leq 0.8V$ (TTL-compatible input)
Input Mode	Falling edge sensitive, latched (active low)
Minimum Pulse Width	12 ns
Active Period	Accepts system triggers during valid acquisition periods via real-time gating; resets system trigger input latch between valid acquisition periods.
Maximum Input Voltage	0 to +5V peak
External Signal Input	TTL-compatible inputs via rear-panel BNC connectors
Input Destinations	Signal 1, 2 (ECLTRG0, 1) Signal 3, 4 (TTLTRG0, 1)
Input Levels	$V_{IH} \geq 2.0V$ ; $V_{IL} \leq 0.8V$ (TTL-compatible input)
Maximum Input Voltage	0 to +5V peak
Input Mode	Active (true) low, level sensitive
Input Bandwidth	Signal 1, 2: 50 MHz square wave minimum; Signal 3, 4: 10 MHz square wave minimum. Input bandwidth only applies to signals to the modules, not round-trip signals into the external signal input and back out the external signal output.
Active Period	Accepts signals during valid acquisition periods via real-time gating
System Trigger Output	TTL-compatible outputs via rear-panel BNC connectors
Source Selection	System trigger (TTLTRG7)
Output Levels	50- $\Omega$ back-terminated TTL output $V_{OH} \geq 4 V$ into open circuit $V_{OH} \geq 2 V$ into 50 $\Omega$ to ground $V_{OL} \leq 0.7 V$ sinking 10 mA
Source Mode	Falling edge sensitive
Active Period	Outputs system trigger state during valid acquisition period; resets system trigger output to false state and resets output latch between valid acquisitions via software

Table 1-5: Rear panel interface (Cont.)

Characteristic	Description
Output Protection	Short-circuit protected (to ground)
External Signal Output	TTL-compatible outputs via rear-panel BNC connectors
Source Selection	Signal 1, 2 (ECLTRG0, 1) Signal 3, 4 (TTLTRG0, 1) 10 MHz clock (CLK10)
Output Levels	50- $\Omega$ back-terminated TTL output $V_{OH} \geq 4$ V into open circuit $V_{OH} \geq 2$ V into 50 $\Omega$ to ground $V_{OL} \leq 0.7$ V sinking 10 mA
Output Modes	User-definable: active (true) low or active (true) high
Output Bandwidth	Signal 1, 2: 50 MHz square wave minimum; Signal 3, 4: 10 MHz square wave minimum. The output bandwidth only applies to signals from the modules, not round-trip signals into the External Signal Input and back out the External Signal Output.
Active Period	Outputs signals during valid acquisition periods; resets signals to false state between valid acquisitions via software
Output Protection	Short-circuit protected (to ground)
Intermodule Signal Line Bandwidth	Minimum bandwidth over which the intermodule signals are specified to operate correctly: Signal 1,2 (ECLTRG0,1): 50 MHz square wave minimum Signals 3,4 (TTLTRG0,1): 10 MHz square wave minimum

Table 1-6: AC power source

Characteristic	Description
Source Voltage and Frequency	90 V <sub>RMS</sub> to 250 V <sub>RMS</sub> , 45 Hz to 66 Hz, continuous range CAT II; 100 V <sub>RMS</sub> to 132 V <sub>RMS</sub> , 360 Hz to 440 Hz, continuous range CAT II
Fuse Rating	
90 V - 250 V Operation (159-0046-00)	UL198/CSA C22.2 0.25 in × 1.25 in, Fast Blow, 8 A, 250 V
90 V - 250 V Operation (159-0381-00)	IEC 127/Sheet 1 5 mm × 20 mm, Fast Blow, 6.3 A, 250 V
Maximum Power Consumption	600 W line power maximum
Steady-State Input Current	6 A <sub>RMS</sub> maximum
Inrush Surge Current	70 A maximum
Power Factor Correction	Yes
On/Standby Switch and Indicator	Front Panel On/Standby switch, with LED indicator located next to switch.  The power cord provides main power disconnect.

Table 1-7: Secondary power

Characteristic	Description			
DC Voltage Regulation	Voltage	Vmin	Vnom	Vmax
	+24 V	23.28 V	24.24 V	25.20 V
	+12 V	11.64 V	12.12 V	12.60 V
	+5 V	4.875 V	5.063 V	5.250 V
	-2 V	-2.10 V	-2.00 V	-1.90 V
	-5.2 V	-5.460 V	-5.252 V	-5.044 V
	-12 V	-12.60 V	-12.12 V	-11.64 V
	-24 V	-25.20 V	-24.24 V	-23.28 V

**Table 1–8: Certifications and compliances: TLA 714 Logic Analyzer Color Portable Mainframe**

<p>EC Declaration of Conformity – EMC</p>	<p>Meets intent of Directive 89/336/EEC for Electromagnetic Compatibility. Compliance was demonstrated to the following specifications as listed in the Official Journal of the European Union:</p> <p>EN 55011                      Class A Radiated and Conducted Emissions</p> <p>IEC 1000–3–2                AC Power Line Harmonic Emissions</p> <p>EN 50082-1 Immunity:</p> <p>    IEC 1000–4–2            Electrostatic Discharge Immunity</p> <p>    IEC 1000–4–3            RF Electromagnetic Field Immunity</p> <p>    IEC 1000–4–4            Electrical Fast Transient/Burst Immunity</p> <p>    IEC 1000–4–5            Power Line Surge Immunity</p> <p>    IEC 1000–4–6            Conducted RF Immunity</p> <p>    IEC 1000–4–11         Power Line Dips/Interruptions Immunity</p> <p>Tektronix, Inc. claims compliance to EMC Directive 89/336/EEC for the following products when used with the above named mainframes:</p> <p>TLA 700 Series Logic Analyzer Modules (TLA 7L1, TLA 7L2, TLA 7L3, TLA 7L4, TLA 7M1, TLA 7M2, TLA 7M3, TLA 7M4, TLA 7N1, TLA 7N2, TLA 7N3, TLA 7N4, TLA 7P2, TLA 7P4)</p> <p>TLA 700 Series Digitizing Oscilloscope Modules (TLA 7D1, TLA 7D2, TLA 7E1, TLA 7E2)</p>
<p>Australia/New Zealand Declaration of Conformity – EMC</p>	<p>Complies with EMC provision of Radiocommunications Act per the following standard(s):</p> <p>AS/NZS 2064.1/2            Industrial, Scientific, and medical Equipment: 1992</p> <p>EN 61010-1:/A2 1995      Safety requirements for electrical equipment for measurement, control, and laboratory use</p>
<p>Approvals</p>	<p>UL3111-1 – Standard for electrical measuring and test equipment</p> <p>CAN/CSA C22.2 No. 1010.1 – Safety requirements for electrical equipment for measurement, control and laboratory use</p>
<p>Installation Category Descriptions</p>	<p>Terminals on this product may have different installation category designations. The installation categories are:</p> <p>CAT III    Distribution-level mains (usually permanently connected). Equipment at this level is typically in a fixed industrial location</p> <p>CAT II    Local-level mains (wall sockets). Equipment at this level includes appliances, portable tools, and similar products. Equipment is usually cord-connected</p> <p>CAT I    Secondary (signal level) or battery operated circuits of electronic equipment</p>
<p>Conditions of Approval</p>	<p>Safety Certifications/Compliances are made for the following conditions:</p> <p>Temperature (operation): +5° C to +40° C</p> <p>Altitude (maximum operation): 2000 meters</p>
<p>IEC Characteristics</p>	<p>Equipment type:</p> <p>Test and Measuring</p> <p>Installation Category II</p> <p>Pollution Degree 2</p> <p>Safety Class I</p>

Table 1-9: Cooling

Characteristic	Description
Cooling System	Forced air circulation (negative pressurization) utilizing six fans operating in parallel
Cooling Clearance	2 inches (51 mm), sides and rear; unit should be operated on a flat, unobstructed surface

Table 1-10: Environmental

Characteristic	Description
Atmospherics	
Temperature (no media in floppy drive)	
Operating	+5° C to +50° C, 15° C/hr maximum gradient, non-condensing. Derated 1° C per 1000 feet (305 m) above 5000 feet (1524 m) altitude.
Nonoperating	-20° C to +60° C, 15° C/hr maximum gradient, non-condensing
Relative Humidity (no media in floppy drive)	
Operating	20% to 80% relative humidity, non-condensing. Maximum wet bulb temperature: +29° C (derates relative humidity to ~22% at +50° C)
Nonoperating	8% to 80% relative humidity, non-condensing. Maximum wet bulb temperature: 29° C (derates relative humidity to ~22% at +50° C)
Altitude	
Operating	To 10,000 ft. (3048 m). Derated 1° C/1000 ft. (305 m) above 5000 ft. (1524 m) altitude
Nonoperating	To 40,000 ft. (12,192 m)
Dynamics	
Random Vibration	Three axis, 30 minutes total, 10 minutes per axis; without VXI instrument modules installed, or with instrument modules installed but not exceeding 5 lbs/slot
Operating	0.1 g <sub>RMS</sub> total from 5 Hz to 500 Hz
Nonoperating	2 g <sub>RMS</sub> total from 5 Hz to 500 Hz
Mechanical Shock	
Operating	Half sine, 30 g, 11 ms duration, three drops each side, 9 shocks total, no media in floppy drive, without instrument modules installed or with instrument modules installed but not exceeding 5 lbs/slot. Meets functional shock requirements of MIL-T-28800E, Type-III, Class 5 limited to top, bottom, face, or rear.

**Table 1-11: Mechanical**

Characteristic	Description
Overall Dimensions	(See Figure 1-1 for overall chassis dimensions)
Height (with feet)	9.25 in (23.5 cm)
Width	17 in (43.18 cm)
Depth	17.5 in (44.45 cm)
Weight	30 lbs 12 oz (13.9 kg) with no modules installed, two dual-wide slot covers, and empty pouch
Shipping Configuration	60 lbs 13 oz (27.58 kg) minimum configuration (no modules), with all standard accessories 86 lbs 9 oz (39.26 kg) full configuration, with two TLA 7P4 modules and standard accessories (including probes)

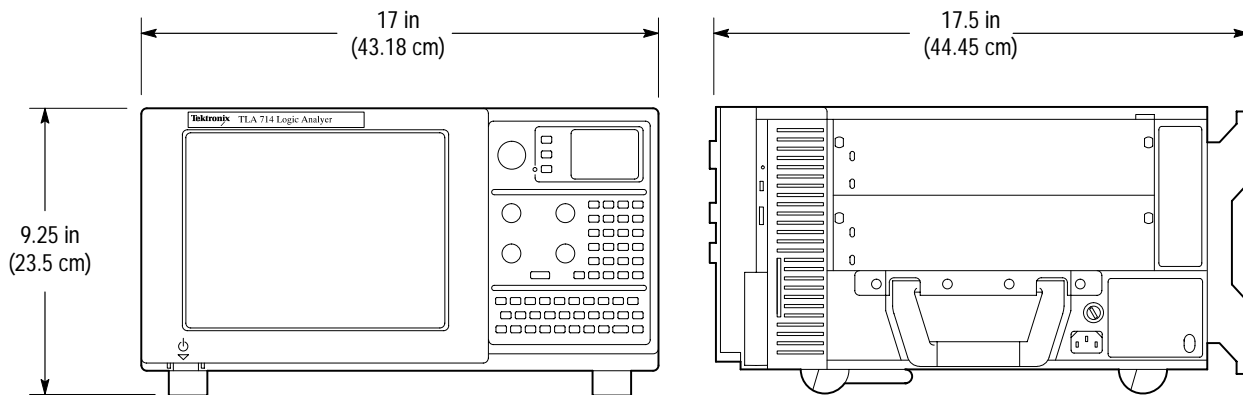

**Figure 1-1: Front and side views of the portable mainframe**



# Operating Information





# Operating Information

This chapter contains information about operating the portable mainframe.

## Installation

Refer to the *TLA 700 Series Logic Analyzer Installation Manual* for complete information on how to install and configure the portable mainframe.

## I/O and Memory Hardware

This section describes the I/O and memory hardware on the portable mainframe including:

- 800 x 600 color display and front panel components
- Dual PC card ports
- Dual USB ports
- Rear-panel I/O ports
- Replaceable hard disk drive, CD ROM drive, floppy disk drive, and SO DIMM memory.

Figure 2–1 shows the front panel. Figure 2–2 shows the rear panel.

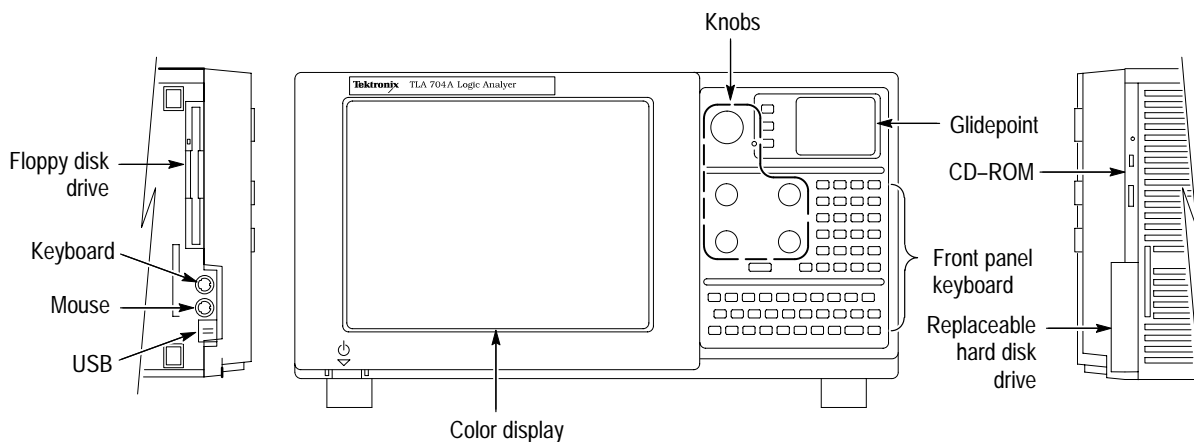

Figure 2–1: TLA 714 portable mainframe front panel

**Color LCD Display** The portable mainframe features a 10.4-inch diagonal, 600 X 800, flat-panel LCD color display.

**Front Panel Keypad, Knobs** The front panel of the portable mainframe includes a QWERTY keyboard, a hexadecimal numeric keypad, and five front panel knobs. The keypads are active simultaneously with the standard external keyboard.

**Front Panel Knobs.** The front panel knobs include a large multi-function knob and four smaller positioning/scale knobs. The multi-function knob is used primarily for incrementing and decrementing values in selected menu boxes. The positioning and scale knobs (Vertical Position, Horizontal Position, Vertical Scale, and Horizontal Scale) provide necessary control of DSO applications, as well as the scrolling of logic analyzer displays.

**Glidepoint Point Device** The glidepoint device, vertically mounted on the front panel, can be used instead of an external mouse when limited bench space is available. The glidepoint device and a standard external mouse are active simultaneously.

**USB Port** There are two USB (universal serial bus) ports. The USB ports can be used for any USB compliant device.

**Table 2-1: USB (universal serial bus) pin assignments**

Pin number	Pin function	Pin number	Pin function
A1	Vcc	B1	Vcc
A2	A DATA -	B2	B DATA -
A3	A DATA +	B3	B DATA +
A4	GND	B4	GND

**Mouse Port** The portable mainframe supports an external pointing device. The mouse connector is a standard six-pin, PS/2-compliant DIN connector. The mouse port can be connected to an external, standard PS/2-compliant three-button mouse.

**Keyboard Port** The portable mainframe has an external keyboard port. The keyboard connector is a standard six-pin PS/2-compliant DIN connector. The keyboard port can be connected to an external, standard PS/2-compliant keyboard.

**PC Card Port** There are two PCMCIA card slots that support an industry standard Type I, II, or III PCMCIA PC card.

<b>Replaceable Hard Disk Drive</b>	There is one replaceable hard drive. Because of the speed at which the PC industry evolves, the hard disk drive is subject to change. This service manual lists the size of the hard disk drive available at the time the product was introduced. Consult your Tektronix Sales Representative for the maximum hard disk drive available.
<b>Fixed Hard Disk Drive</b>	It is possible to add a fixed hard disk drive to the TLA 714 mainframe which is available through the TLA 7UP mainframe upgrade kit. Contact your Tektronix representative for more information on available upgrades to your mainframe.
<b>CD ROM Drive</b>	The portable mainframe has one CD ROM drive.
<b>Floppy Disk Drive</b>	The portable mainframe has one standard 1/2 inch drive that supports 3.5 inch, 1.44 MByte, high-density/double-sided floppy disk media.
<b>Memory SO DIMMs</b>	The portable mainframe utilizes 144-pin SO DIMM memory devices. The memory devices must have gold pins.  Refer to the specifications for memory parameters.
<b>External I/O BNCs</b>	The portable mainframe has four test I/O BNC connectors on the rear panel (see Figure 2-2) these connectors are labeled:

SYSTEM TRIG IN  
SYSTEM TRIG OUT  
EXTERNAL SIGNAL IN  
EXTERNAL SIGNAL OUT

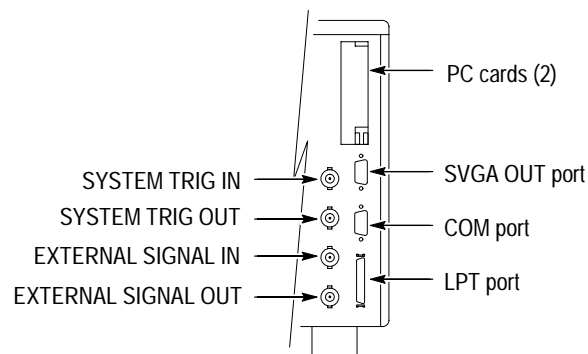

**Figure 2-2: Portable mainframe rear panel**

**SYSTEM TRIG IN Connector.** The System Trigger Input is a TTL-compatible signal input that is user definable in software. The System Trigger Input utilizes a BNC connector. Refer to the *TLA 700 Series Logic Analyzer User Manual* for additional information.

**SYSTEM TRIG OUT Connector.** The System Trigger Output is a TTL-compatible output signal that is user definable in software. The System Trigger Output utilizes a BNC connector. Refer to the *TLA 700 Series Logic Analyzer User Manual* for additional information.

**EXTERNAL SIGNAL IN Connector.** The External Signal Input is a TTL-compatible input signal that is user definable in software. The External Signal Input utilizes a BNC connector. Refer to the *TLA 700 Series Logic Analyzer User Manual* for additional information.

**EXTERNAL SIGNAL OUT Connector.** The External Signal Output is a TTL-compatible output signal that is user definable in software. The System Trigger Output utilizes a BNC connector. Refer to the *TLA 700 Series Logic Analyzer User Manual* for additional information.

**SVGA Port**

The SVGA OUT port supports an industry standard SVGA color monitor. The connector is a 15-pin, sub-D SVGA-compliant connector. See Table 2–2 for pin assignments.

**Table 2–2: SVGA OUT pin assignments**

Pin number	Pin function	Pin number	Pin function
1	RED	2	GRN
3	BLU	4	NC
5	GND	6	GND
7	GND	8	GND
9	(KEY)	10	GND
11	NC	12	DDC DAT
13	HSYNC	14	VSYNC
15	DDD CLK		

**COM Port** The COM port is an industry standard RS-232 serial port.

Pin number	Pin function	Pin number	Pin function
1	DCD	2	RXD
3	TXD	4	DTR
5	GND	6	DSR
7	RTS	8	CTS
9	Ring Indicator		

**LPT Port** The LPT port is a parallel printer port. This parallel printer port supports standard Centronics mode, Enhanced Parallel Port (EPP), or Microsoft high-speed mode (ECP) and utilizes a 36-pin high density Centronics-compliant connector. See Table 2–3 for pin assignments.

**Table 2–3: LPT (parallel interface) pin assignments**

Pin number	Pin function	Pin number	Pin function
1	BUSY	19	GND
2	SLCT	20	GND
3	ACK*	21	GND
4	ERR*	22	GND
5	PE	23	GND
6	D0	24	GND
7	D1	25	GND
8	D2	26	GND
9	D3	27	GND
10	D4	28	GND
11	D5	29	GND
12	D6	30	GND
13	D7	31	GND
14	INIT*	32	GND
15	STB*	33	GND
16	SLIN*	34	GND
17	AFD*	35	GND
18	HI	36	H1

See IEEE specification P1284-C for pin connection definitions for other modes

## Operating System and Application Interface

The portable mainframe comes with the Microsoft Windows operating system factory-installed. Operations and capabilities when running on the portable mainframe are the same as with Microsoft Windows running on a high-performance personal computer. Windows Help is available from the Start menu of the Windows Task Bar.

The portable mainframe also comes with the TLA 700 series application software configured at the factory to launch after the logic analyzer boots up and the operating system is running. The TLA 700 series application software controls data acquisition and processing by the logic analyzer. The TLA 700 series application software is included with the product. Refer to the *TLA 700 Series Installation Manual* if you need to reinstall the TLA 700 series application software.

### Online Help

Most of the user information for operating the portable mainframe is available through online help.

Refer to the TLA 700 series online help for more information on the individual menus, icons, and fields within each window. You may also want to refer to the *TLA 700 Series Logic Analyzer User Manual* for additional information.

Refer to your Microsoft Windows documentation for additional information on using Windows help.

## Diagnostics

The portable mainframe contains the following diagnostics:

- BIOS diagnostic tests (automatic)
- TLA 700 series application software (automatic and manual)
- TLA 700 series mainframe diagnostics (manual)
- QA+Win32 (manual)

All diagnostics (both automatic and manually executed tests) are useful for troubleshooting purposes.

The portable mainframe performs BIOS and TLA 700 series application diagnostics for the mainframe and all installed modules every time you power on. The diagnostics window displays when any of the diagnostic tests fail. To access the diagnostics tests in the TLA 700 series application software, use the System pull-down menu.

In addition to Power-on Diagnostics, the Portable Mainframe also contains mainframe diagnostics and QA+Win32 diagnostics for the PC hardware.

For more information about diagnostics, refer to the *Maintenance* chapter.







# Theory of Operation



# Theory of Operation

This section provides a brief overview of the board level theory of operation for the portable mainframe. Refer to page 6–2 for a functional block diagram.

## Portable Mainframe

The portable mainframe contains the following major components:

<b>Power Supply</b>	The power supply provides all voltages and currents to the portable mainframe. The power supply connects to the backplane at P400 and P401.
<b>Backplane</b>	The backplane connects the power supply secondary to the remainder of the system, including the fans, distributes the precision 10-MHz (CLK10) system clock, and supports all communication between the instrument modules.
<b>Controller Board</b>	The controller board provides the portable mainframe with a high-performance PC-based controller architecture, and interfaces to the backplane bus and front panel. The controller board mounts vertically on the left side of the instrument and connects to the back of the backplane. The controller board provides I/O to the rear panel and is the source of the 10-MHz (CLK10) system clock.
<b>Front Panel Interface Board</b>	The front panel interface board interconnects the controller board, the flat-panel display, the floppy disk drive, the front-panel keypad and glidepoint, dual USB ports, and the external mouse and keyboard ports. Dual 50-pin cables connect the front panel interface board to the controller board. The interface board also supplies the PC speaker.
<b>Front Panel Controller Board</b>	The front panel controller board combines signals from the front-panel hex keypad, the front-panel QWERTY keypad, and an external keyboard to generate or receive standard keyboard scan-codes from the controller board.
<b>Mechanical Chassis</b>	The mechanical chassis provides the mechanical support structure for the instrument, and includes the cooling system, the modular-card cage, the EMI shielding system, and all the subsystems previously listed.





# Maintenance



# Maintenance

This chapter provides procedures for inspecting and cleaning the portable mainframe, removing and replacing internal chassis components, and isolating problems to the board or replacement part level.

To repair, you must exchange or replace the failed part; this manual does not provide component-level procedures for isolating components on the failed part.

## Preparation

The information in this chapter is designed for use by qualified service personnel. Read the *Safety Summary* at the front of this manual before attempting any procedures in this chapter. Refer to the *Operating Information* chapter for information on the location of controls, indicators, and connectors used with the chassis.

## Preventing ESD

When performing any service which requires internal access to the portable mainframe, adhere to the following precautions to avoid damaging internal circuit boards and their components due to electrostatic discharge (ESD).



---

**CAUTION.** *Many components within the chassis are susceptible to static-discharge damage. Service the chassis only in a static-free environment.*

*Observe standard handling precautions for static-sensitive devices while servicing the chassis.*

*Always wear a grounded wrist strap, or equivalent, while servicing the chassis.*

---

1. Minimize handling of static-sensitive circuit boards.
2. Transport and store static-sensitive circuit boards in their static protected containers or on a metal rail. Label any package that contains static-sensitive boards.
3. Discharge the static voltage from your body by wearing a grounded antistatic wrist strap while handling these circuit boards. Do service of static-sensitive circuit boards only at a static-free work station.
4. Nothing capable of generating or holding a static charge should be allowed on the work station surface.

5. Handle circuit boards by the edges when possible.
6. Do not slide the circuit boards over any surface.
7. Avoid handling circuit boards in areas that have a floor or work-surface covering capable of generating a static charge.



---

**WARNING.** To avoid electric shock, always power off the chassis and disconnect the power cord before cleaning or servicing the chassis.

---

## Inspection and Cleaning

The portable mainframe is inspected mechanically and electrically before shipment. It should be free of marks or scratches and should meet or exceed all electrical specifications. To confirm this, inspect the chassis for physical damage incurred during transit. Retain the chassis packaging in case shipment for repair is necessary. If there is damage or deficiency, contact your local Tektronix representative.

Cleaning procedures consist of exterior and interior cleaning of the chassis. Clean the chassis as needed, based on the operating environment. Refer to the appropriate module service manuals for information on cleaning individual TLA 700 Series modules.

### Interior Cleaning

Use a dry, low-velocity stream of air to clean the interior of the chassis. Use a soft-bristle, non-static-producing brush for cleaning around components. If you must use a liquid for minor interior cleaning, use a 75% isopropyl alcohol solution and rinse with deionized water.

### Exterior Cleaning

Clean the exterior surfaces of the chassis with a dry lint-free cloth or a soft-bristle brush. If any dirt remains, use a cloth or swab dipped in a 75% isopropyl alcohol solution. Use a swab to clean narrow spaces around controls and connectors. Do not use abrasive compounds on any part of the chassis that may damage the chassis.

Clean the On/Standby switch using a dampened cleaning towel. Do not spray or wet the switch directly.





**CAUTION.** Avoid getting moisture inside the chassis during exterior cleaning; use just enough moisture to dampen the cloth or swab.

*Do not wash the front-panel On/Standby switch. Cover the switch while washing the chassis.*

*Use only deionized or distilled water when cleaning. Use a 75% isopropyl alcohol solution as a cleanser and rinse with deionized or distilled water.*

*Do not use chemical cleaning agents; they may damage the chassis. Avoid chemicals that contain benzene, toluene, xylene, acetone, or similar solvents.*

---

### Flat Panel Display Cleaning

The portable mainframe display is a soft plastic display and must be treated with care during cleaning.



**CAUTION.** Improper cleaning agents or methods can damage the flat panel display.

*Avoid using abrasive cleaners or commercial glass cleaners to clean the display surface.*

*Avoid spraying liquids directly on the display surface.*

*Avoid scrubbing the display with excessive force.*

---

Clean the flat panel display surface by gently rubbing the display with a clean-room wipe (such as Wypall Medium Duty Wipes, #05701, available from Kimberly-Clark Corporation).

If the display is very dirty, moisten the wipe with distilled water or a 75% isopropyl alcohol solution and gently rub the display surface. Avoid using excess force or you may damage the plastic display surface.



# Removal and Installation Procedures

This section contains procedures for removal and installation of all mechanical and electrical field-replaceable parts.

## Preparation



---

**WARNING.** Before performing this or any other procedure in this manual, read the Safety Summary found at the beginning of this manual.

To prevent possible injury to service personnel or damage to the portable mainframe, read Installation in Chapter 2, and Preventing ESD on page 4–1 in this section.

---



---

**WARNING.** Dangerous voltages may be present.

Before performing any procedure in this subsection, disconnect the power cord from the line voltage source.

Failure to do so could cause serious injury or death.

---

## General Instructions

---

**NOTE.** Read the following general instructions before removing a part.

Following these instructions helps ensure that you remove the part to be serviced while removing the minimum number of additional parts.

---

First read over the *Summary of Procedures* that follows to understand how the procedures are grouped. Then see Table 4–1 for a list of the tools needed to remove and install replaceable parts in this mainframe.

If you are removing a part for service, begin by looking up the procedure for that part. If any procedures are listed as required in advance in order to gain access to the part, perform those procedures first.

## Equipment Required

Most parts in this mainframe can be removed with a screwdriver with a T-15 Torx tip.

**Table 4-1: Tools required for part removal**

Name
Screwdriver with a T-15 Torx tip
Screwdriver with a T-10 Torx tip
Flat Blade Screwdriver
Phillips screwdriver with a #1 tip
Pliers
Side cutters
Scribe or jeweler's screwdriver
Cable ties

## Exploded View

Figure 4-1 shows the locations of the parts of the portable mainframe.

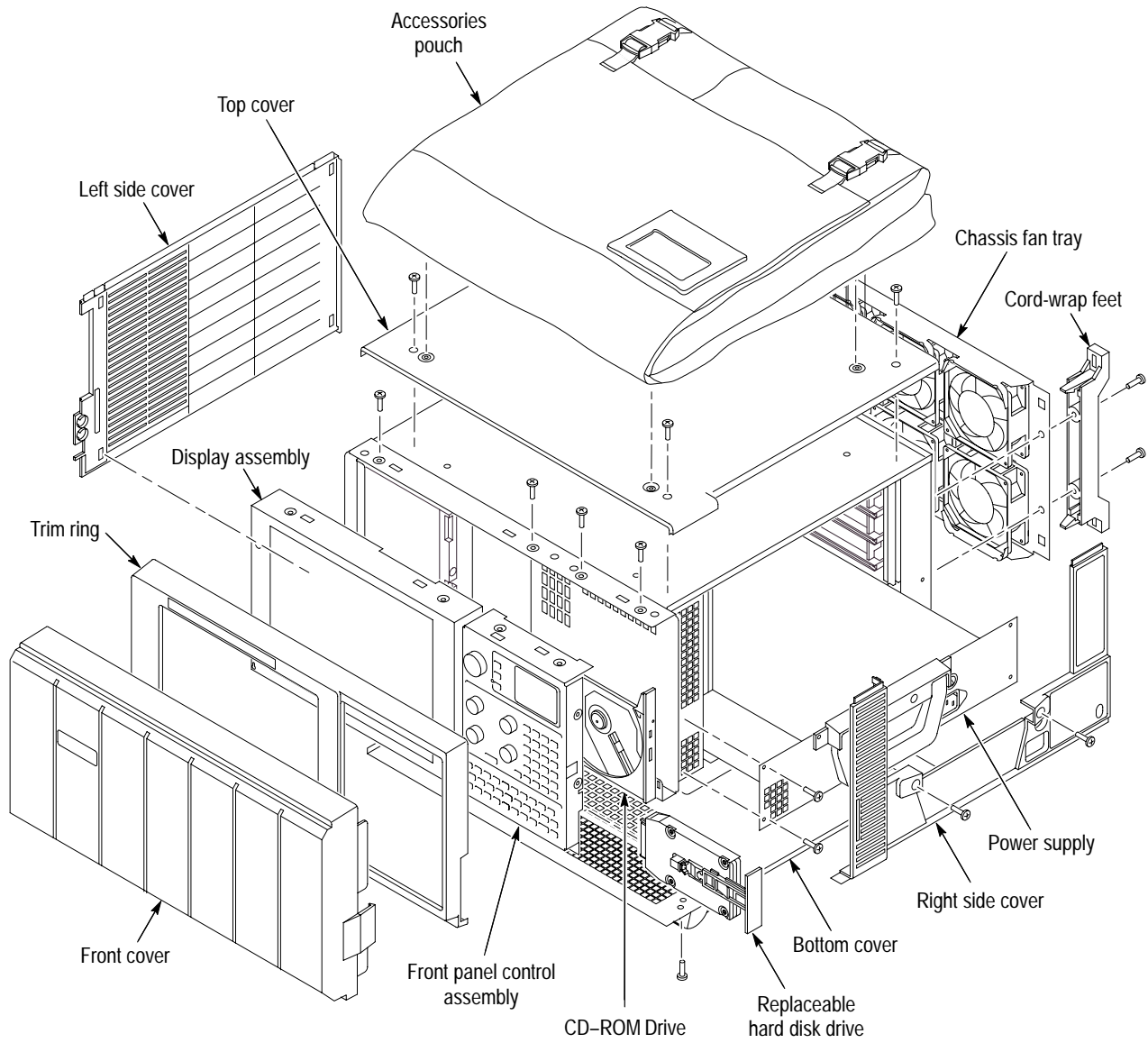

Figure 4-1: External parts

## Removing the Replaceable Hard Disk Drive



**CAUTION.** Do not remove the replaceable hard disk drive when the mainframe is powered on.

The replaceable hard disk drive may be permanently damaged if it is removed while the mainframe is powered on.

Always power down the mainframe before removing the replaceable hard disk drive.

---

Verify that the chassis is powered down.

The hard disk drive cartridge is removed by depressing it. This will release the latch. Pull on the removable hard disk drive to remove it from the chassis. Refer to Figure 4-3 and 4-4.

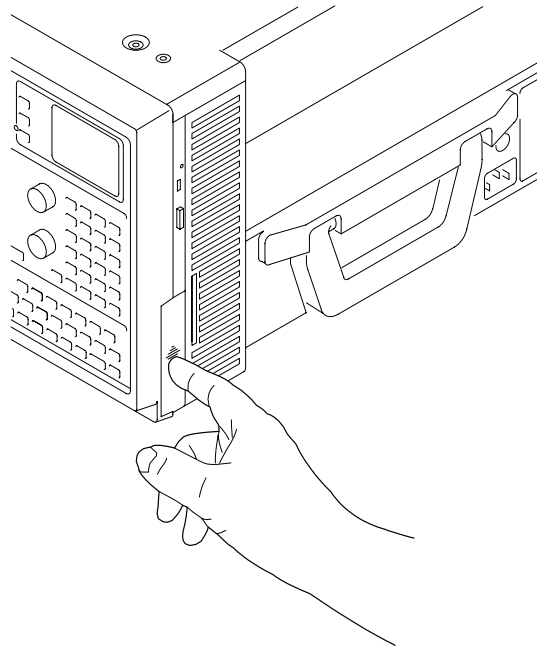

**Figure 4-2: Depress the latch**

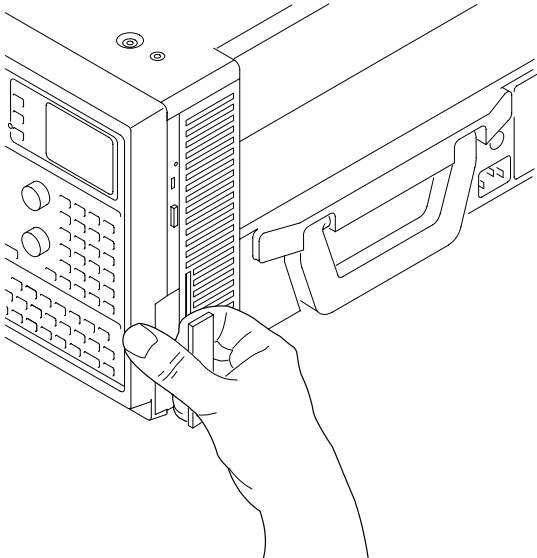

Figure 4-3: Unlatching the hard disk drive cartridge

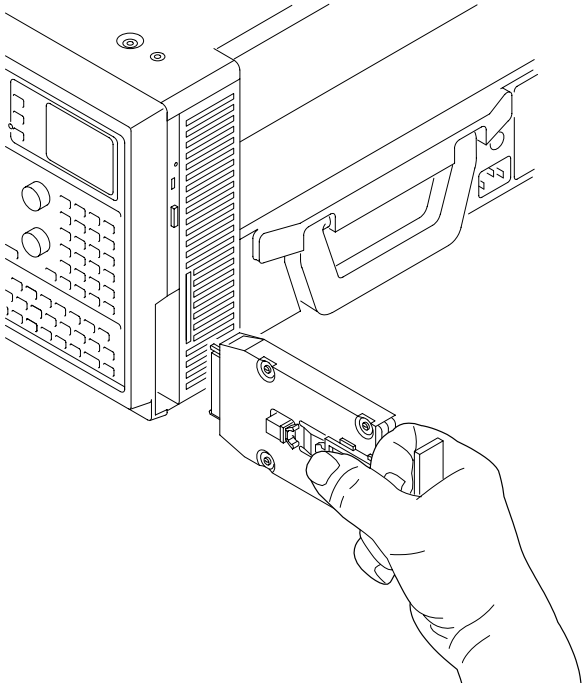

Figure 4-4: Removing the hard disk drive cartridge

## Removing the Hard Disk Drive From The Cartridge

To remove the hard disk drive from the cartridge, refer to Figure 4-5 and follow these steps:

1. Remove the four screws that fasten the hard disk drive to the cartridge.
2. Carefully remove the hard disk drive from the cartridge, and remove the cable assembly from the connector on the hard disk drive.

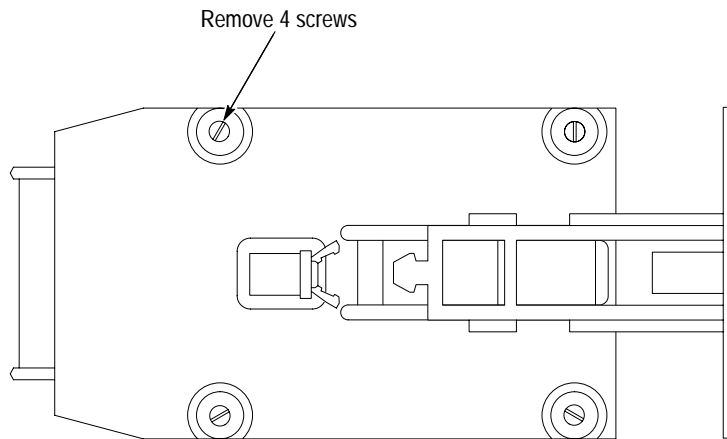

Figure 4-5: Removing the hard disk drive from the cartridge

## Trim Ring

You will need a flat-bladed screwdriver (or other small prying tool) to remove the trim ring.

**Removal** Use the following procedure to remove the trim ring:

1. Set the mainframe with the cord-wrap feet on the work surface and the bottom facing you.
2. Grasp the trim ring by its bottom edge and pull toward you to detach the three plastic snaps. (Alternatively, you can use a flat-bladed screwdriver or other small prying tool to help you detach the snaps.) Then, swing the bottom of the ring upward and work the rest of the ring off the front panel.



**Installation** Use the following procedure to replace the trim ring:

- 3. Replace the trim ring on the front panel. Start at the top edge and work around to the bottom until the three plastic snaps engage. Press the trim ring down all around the edges until it is completely seated.

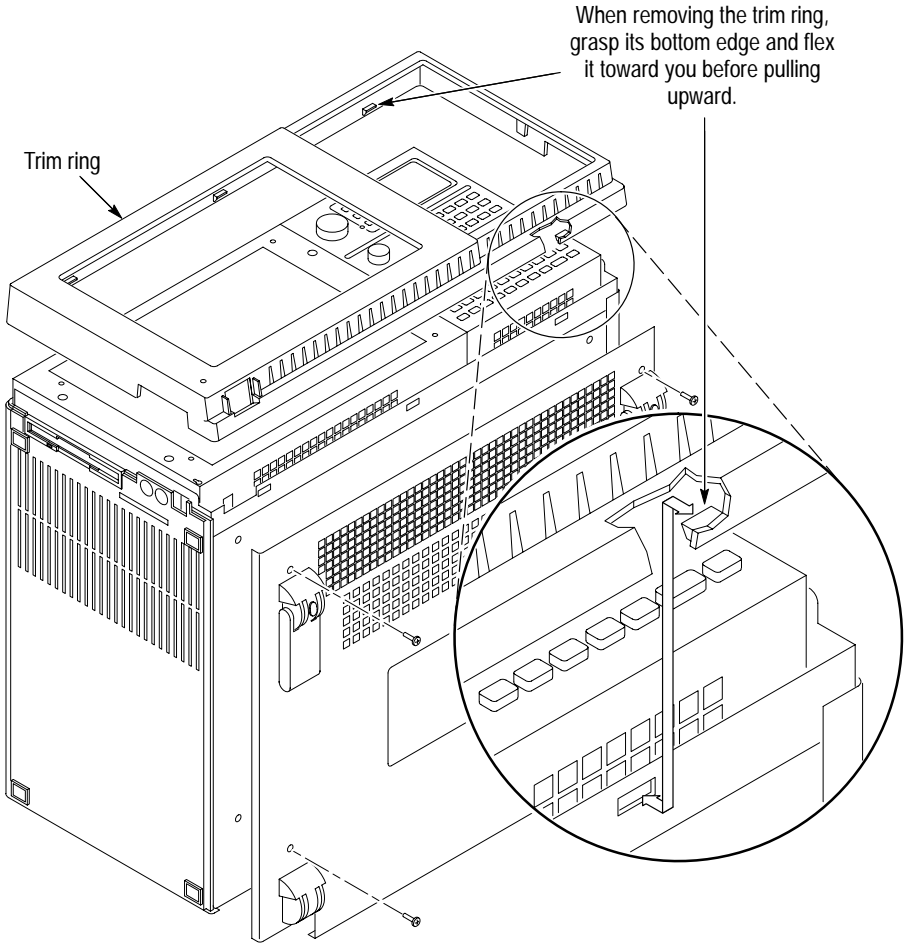

Figure 4-6: Trim ring removal

## Flat Panel Display Assembly

You will need a screwdriver with a size T-15 Torx tip to perform this procedure.

**Removal** Use the following procedure to remove the flat panel display assembly:

1. Do the Trim Ring removal procedure on page 4–10.
2. Remove the five screws that attach the flat panel display assembly to the mainframe: two screws at the bottom of the assembly on the front of the instrument, two screws on the top, and one screw on the left side. (See Figure 4–7 on page 4–13).
3. Lift the bottom edge of the flat panel display assembly and rotate it upward and off the front face of the mainframe.
4. Detach the cable connecting the flat panel display assembly to connector J209 on the front panel interface board.
5. Detach the five pin display backlight connector.

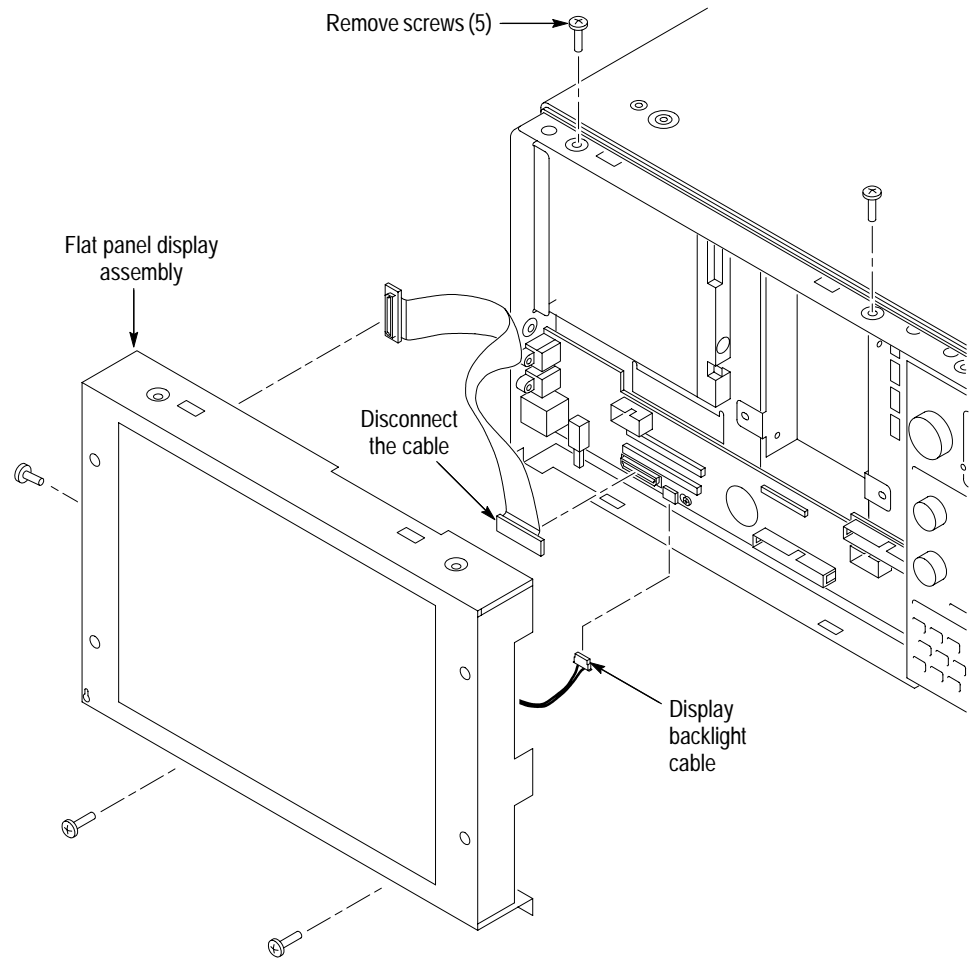

**Figure 4-7: Flat panel display assembly removal**

### **Installation**

Use the following procedure to reinstall the flat panel display assembly:

1. Reattach the cable connecting the flat panel display assembly to the interface board.
2. Reattach the display backlight cable.
3. Reinstall the flat panel display assembly by first inserting the top edge and then rotating it downward into position. (Be sure the tabs are engaged at the top of the assembly. Insert the five screws that attach the flat panel display assembly to the mainframe: two screws at the bottom of the assembly on the front of the instrument, two screws on the top, and one screw on the left side. (See Figure 4-7 on page 4-13).
4. Do the *Trim Ring* installation on page 4-11.

## Floppy Disk Drive

You will need a screwdriver with a size T-15 Torx tip to perform this procedure.

### Removal

Use the following procedure to remove the floppy disk drive:

1. Do the *Trim Ring* Removal procedure, steps 1-5, on page 4–10.
2. Do the *Flat Panel Display Assembly* removal procedure, page 4–12.
3. Detach the data cable from J103 on the front panel interface board; there is a release latch on both the floppy drive and the interface board connectors.
4. Remove the two screws securing the floppy disk drive to the chassis.
5. Remove the floppy disk drive.
6. Remove the cable from the floppy disk drive.

### Installation

Use the following procedure to reinstall the floppy disk drive:

1. Attach the data cable to the floppy disk drive.
2. Reposition the disk drive.
3. Insert the two screws securing the floppy disk drive to the chassis.
4. Attach the data cable to J103 on the interface board.
5. Do the *Front Panel Display Assembly* installation procedure, page 4–13.
6. Do the *Trim Ring* installation on page 4–11.

## Front Panel Interface Board

You will need a screwdriver with a T-15 Torx head to perform this procedure.

### Removal

The front panel interface board is located under the front panel display. Use the following procedure to remove the interface board:

1. Do the *Trim Ring* Removal procedure, steps 1-5, on page 4–10.
2. Do the *Flat panel Display Assembly* removal procedure, page 4–12.
3. Detach the ribbon cables at J100, J101, J209, J102, and J103.
4. Remove the one screw securing the interface board, and the two screws on the side panel.

5. Grasp the board and slide the board to the right (toward the front panel control assembly) and lift the board out.

**Installation** Use the following procedure to reinstall the interface board:

1. Reposition the interface board on the mounting pegs, and slide it to the left (i.e., away from the front panel control assembly).
2. Insert the screw securing the interface board to the front, and the two screws securing the interface board to the side panel.
3. Reattach cables at J100, J101, J209, J102, and J103.
4. Do the *Display Assembly* installation procedure, page 4–13.
5. Do the *Trim Ring* installation on page 4–11.

## Front Panel Control Assembly

You will need a screwdriver with a size T-15 Torx tip to perform this procedure.

**Removal** Use the following procedure to remove the front panel control assembly:

1. Do the *Trim Ring* Removal procedure on page 4–10.
2. Remove the flat panel display as shown on page 4–12.
3. Remove the four screws that attach the front panel control assembly to the mainframe: two at the bottom of the assembly on the front of the instrument, two on the top. (See Figure 4–8 on page 4–16).

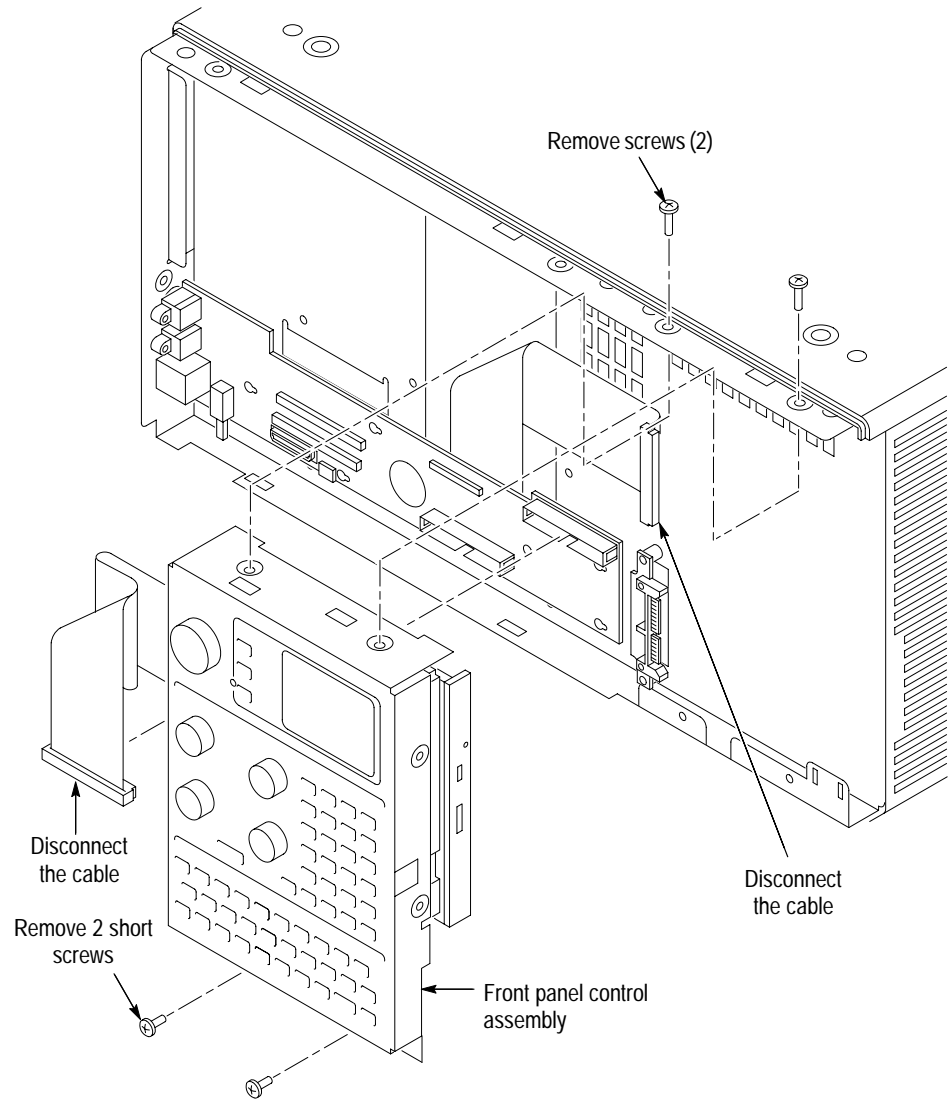

**Figure 4-8: Front-panel control assembly removal**

4. Lift the bottom edge of the front control panel assembly and rotate it upward and off the front face of the mainframe.
5. Detach the two ribbon cables connecting the front panel panel assembly and the CD ROM to the interface board.

---

**NOTE.** Procedures for removing the knobs, elastomeric keypad, and Front Panel Control Board are found in Procedures for Internal Parts, which begins on page 4-33.

---

- Installation** Use the following procedure to install the front panel control assembly:
1. Reattach the cable connecting the front panel control assembly to the interface board.
  2. Reinstall the front panel control assembly by first inserting the top edge and then rotating it downward into position. (Be sure the tabs are engaged at the top of the assembly. Insert the five screws that attach the front panel control assembly to the mainframe: two at the bottom of the assembly on the front of the instrument, two on the top, and one on the right side. (See Figure 4–8 on page 4–16).
  3. Do the *Trim Ring* installation on page 4–11.

## Front Panel Knobs

No tools are needed to remove or replace a front panel knob on the portable mainframe.

- Removal** To remove a front panel knob, grasp the knob and pull it straight out from the front panel.
- Installation** To reinstall a knob, align the knob to a shaft and push in as far as it will go.

## CD ROM Drive

The CD ROM drive is attached to the underside of the front panel control assembly. You will need a screwdriver with a size T-15 and T-10 Torx tip.



---

**CAUTION.** *The CD ROM drive uses a laser.*

*Use of procedures other than those specifically listed herein may result in hazardous radiation exposure.*

*Do not attempt to open the CD ROM drive covers, or attempt any type of repair on the CD ROM drive.*

*Refer all servicing of the CD ROM drive to qualified personnel.*

---

### Removal

Use the following procedure to remove the CD ROM drive:

1. Do the Trim Ring removal procedure, steps 1-5, on page 4–10.
2. Do the *Display Assembly* removal procedure on page 4–12.
3. Do the *Front Panel Control Assembly* removal on page 4–15.
4. Remove the five screws that attach the CD ROM drive to the front panel control assembly: three from the left side, two from the right side.

### Installation

Use the following procedure to reinstall the CD ROM drive:

1. Reposition the CD ROM drive within the bracket.
2. Install the five screws that attach the CD ROM drive to the front panel control assembly: three from the left side, two from the right side.
3. Do the *Front Panel Control Assembly* install on page 4–17.
4. Do the *Display Assembly* installation procedure, page 4–13.
5. Do the *Trim Ring* installation on page 4–11.



## Bottom Cover

Removing the bottom cover should only be necessary when replacing a flip stand or rear foot. You may also need to loosen the mounting screws on one side of the bottom cover to remove or replace either side cover or to remove the power supply.

You will need a screwdriver with a size T-15 Torx tip to perform this procedure.

**Removal** Use the following procedure to remove the bottom cover:

1. Set the mainframe with the cord-wrap feet on the work surface and the bottom facing you.
2. Remove the four screws that attach the bottom cover to the mainframe. (See Figure 4-6 on page 4-11.)
3. Lift bottom cover off.

**Installation** Reposition the bottom cover on the bottom surface of the portable mainframe.

Insert the four screws that attach the bottom cover to the mainframe. (See Figure 4-6 on page 4-11.)

## Top Cover

You will need a screwdriver with a size T-15 Torx tip to perform this procedure.

**Removal** Use the following procedure to remove the top cover:

1. Set the mainframe with the bottom on the work surface and the front facing you.
2. Unsnap the accessories pouch from the top cover.
3. Do the Trim Ring removal procedure on page 4–10.
4. Remove the four screws that attach the top cover to the mainframe. (See Figure 4–9 on page 4–21.)
5. Lift the top cover off.

**Installation** Use the following procedure to reinstall the top cover:

1. Reposition the top cover on the portable mainframe.
2. Insert the four screws that attach the top cover to the mainframe. (See Figure 4–9 on page 4–21.)
3. Do the Trim Ring installation procedure on page 4–10.
4. Reattach the accessories pouch to the top cover. (It snaps on.)

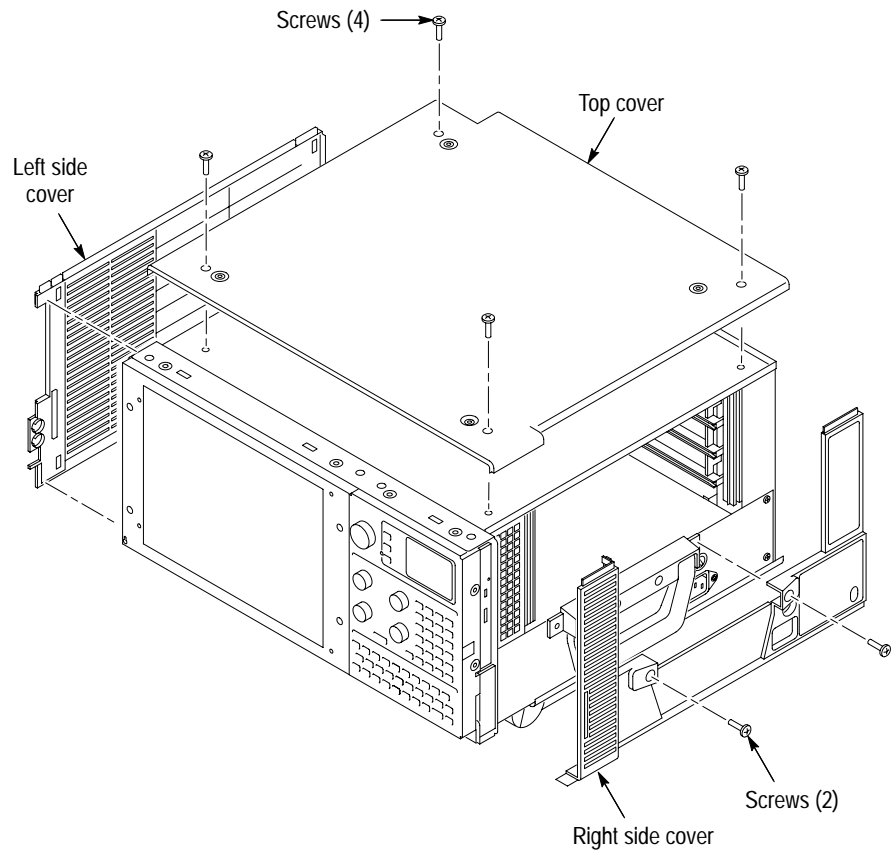

Figure 4-9: Top and side cover removal

## Left Side Cover

No screws attach the left side cover to the mainframe. However, you must loosen the two screws closest to the left side of the bottom cover in order to remove the left side cover.

You will need a screwdriver with a size T-15 Torx tip to perform this procedure.

**Removal** Use the following procedure to remove the left side cover:

1. Do the Trim Ring removal procedure, steps 1-5, on page 4-10.
2. Do the *Top Cover* removal procedure on page 4-20.
3. Loosen the two screws on the bottom cover closest to the left side of the mainframe. (See Figure 4-6 on page 4-11.)
4. Remove the left side cover.

**Installation** Reposition the left side cover and tighten the two bottom cover screws nearest the left side of the mainframe. Do the *Top Cover* installation procedure as shown on page 4–20.

## Right Side Cover

You will need a screwdriver with a size T-15 Torx tip to perform this procedure.

**Removal** Use the following procedure to remove the left side cover:

1. Remove any installed modules from the portable mainframe.
2. Do the Trim Ring removal procedure, steps 1-5, on page 4–10.
3. Do the *Line Cord and Line Fuse* removal procedure, page 4–23.
4. Do the *Top Cover* removal procedure, page 4–20.
5. Loosen the two screws on the bottom cover closest to the right side of the mainframe. (See Figure 4–6 on page 4–11.)
6. Remove the two screws that attach the right side cover to the power supply. (See Figure 4–9 on page 4–21.)
7. Remove the right side cover.

**Installation** Use the following procedure to reinstall the right side cover:

1. The two screws near the right side of the bottom cover should be loosely fastened.
2. Reseat the right side cover in the groove of the bottom cover.
3. Insert the two screws that attach the right side cover to the power supply.
4. Tighten the two bottom cover screws nearest the right side of the mainframe.
5. Do the *Top Cover* installation procedure, page 4–20.
6. Do the *Trim Ring* installation procedure, page 4–10
7. Do the *Line Cord and Line Fuse* installation procedure, page 4–23.

## Line Cord and Line Fuse

You will need a flat-bladed screwdriver to perform this procedure.

**Removal** Use the following procedure to remove the line cord and line fuse:

1. Unplug the instrument from power.
2. Set the mainframe with the bottom on the work surface and the right side facing you. If you are replacing the line fuse, do the next step; if you are replacing the line cord only, skip to step 4.
3. Find the fuse cap on the right side cover. (See Figure 4–10 on page 4–24.) Remove the fuse cap by turning it counterclockwise using a flat-bladed screwdriver, and then remove the line fuse.
4. Find the line cord on the right side cover. (See Figure 4–10 on page 4–24.) Unplug the line cord from its receptacle. Grasp the line cord on either side of the line cord retaining clamp. Rotate the line cord 90 degrees counterclockwise. Pull the line cord and clamp away from the side panel mounting hole to complete the removal.

**Installation** Use the following procedure to reinstall the line fuse and line cord:

1. If you are replacing the line fuse, insert it into the line fuse receptacle. If you are not replacing the line fuse, skip to step 3.
2. Replace the fuse cap by turning it clockwise using a flat bladed screwdriver.
3. Insert the line cord and retaining clamp into the mainframe side panel mounting hole, with the line cord oriented up and down.
4. Rotate the line cord 90 degrees counterclockwise.
5. Plug the line cord into its receptacle.

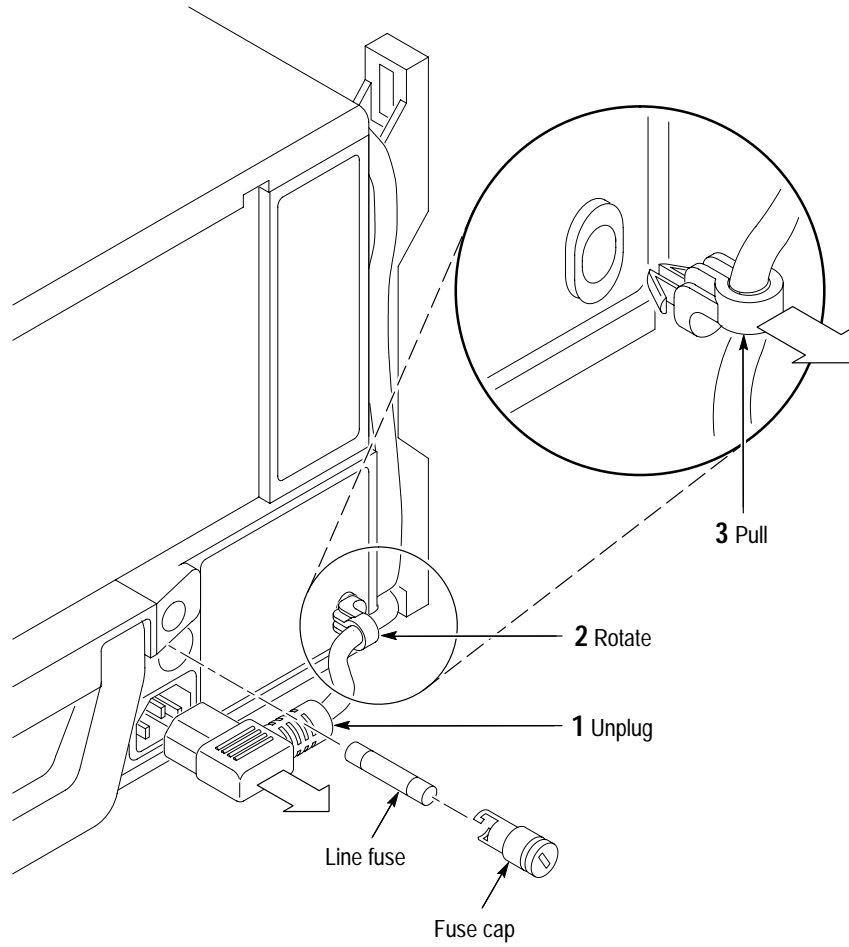

**Figure 4-10: Line cord and line fuse removal**

# Power Supply

You will need a screwdriver with a size T-15 Torx tip to perform this procedure.

**Removal** Use the following procedure to remove the power supply:

1. Do the removal procedures for *Bottom Cover* (page 4-19), *Top Cover* (page 4-20), and *Right Side Cover* (page 4-22).

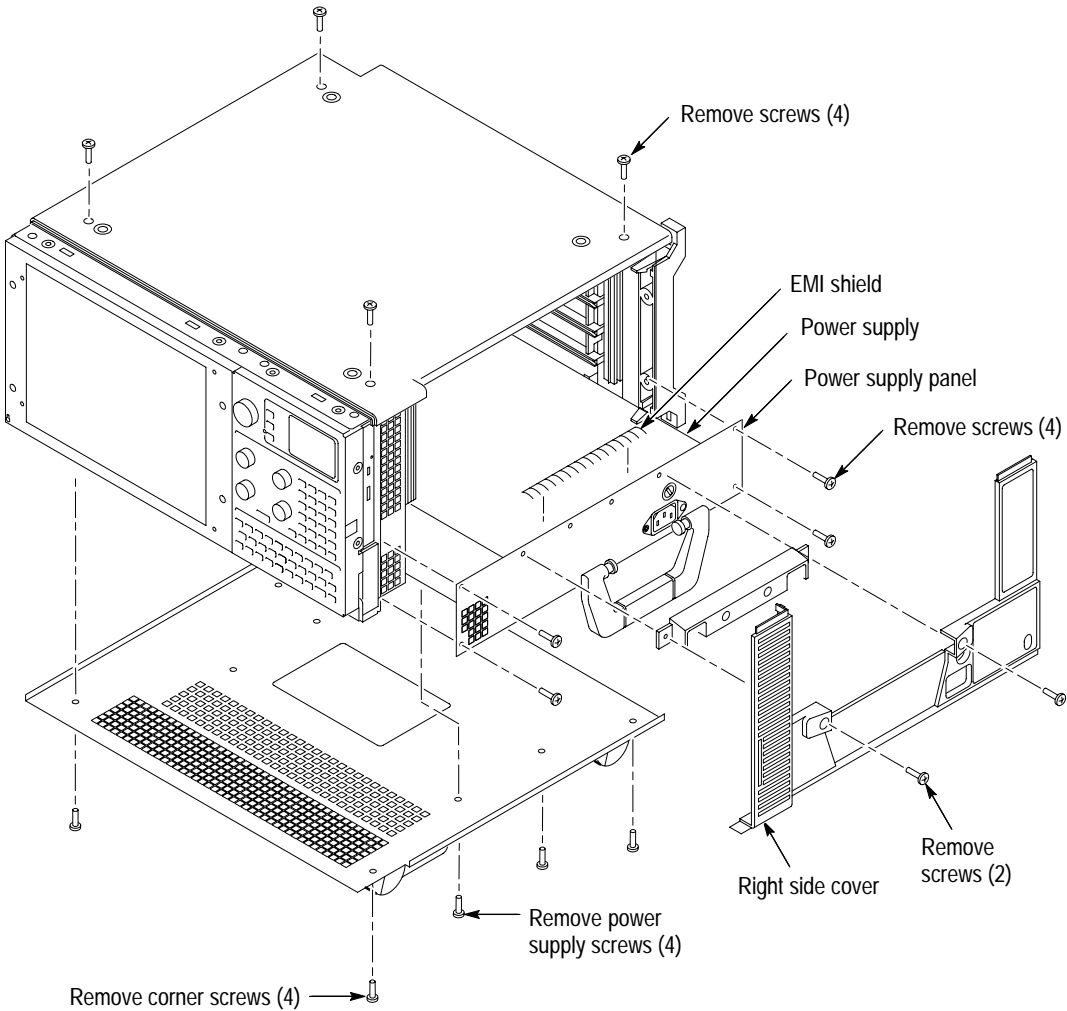

Figure 4-11: Power supply removal

2. Remove the four screws from the right side and the four screws from the bottom that secure the power supply to the chassis.
3. Pull on the handle to remove the power supply from the chassis.

4. Remove the handle and power supply panel before packaging the power supply for exchange.

---

**NOTE.** Replacement power supplies do not come equipped with a power supply panel or handle.

---

### Installation

Use the following procedure to reinstall the power supply:

1. Install the power supply panel and handle onto the replacement power supply.
2. Insert the power supply into the chassis. Press firmly to make sure the power supply is fully seated.
3. Insert the four screws on the right side and the four screws on the bottom that secure the power supply to the chassis.
4. Do the installation procedures for *Bottom Cover* (page 4–19), then *Right Side Cover* (page 4–22), and then *Top Cover* (page 4–20).

## Rear Chassis Fan Tray

You will need a screwdriver with a size T-15 Torx tip to perform this procedure.

### Removal

Use the following procedure to remove the rear chassis fan tray:

1. Set the mainframe so that the bottom is on the work surface and the rear chassis fan tray faces you.
2. Remove the four screws located within the cord-wrap feet that secure the rear chassis fan tray to the mainframe. (See Figure 4–12 on page 4–27.)
3. Grasp the left cord-wrap foot (facing the fan tray) and swing the left side of the fan tray away from the mainframe.
4. Disconnect the cable connecting the rear chassis fan tray to the backplane board.
5. Remove the rear chassis fan tray.



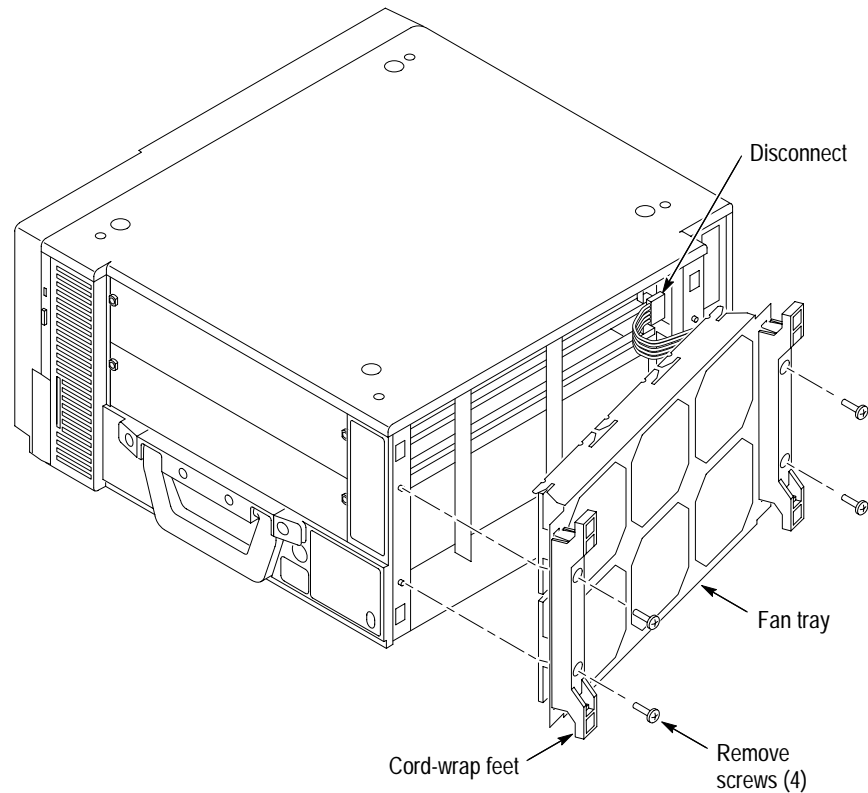

**Figure 4-12: Rear chassis fan tray removal**

### Installation

Use the following procedure to reinstall the rear chassis fan tray:

1. Redress the cable connecting the rear chassis fan tray to the backplane board if necessary.
2. Reconnect the cable connecting the rear chassis fan tray to the backplane board.
3. Reposition the rear chassis fan tray.
4. Reposition the cord-wrap feet (they snap into holes on the rear chassis fan tray), and insert the four screws that secure the rear chassis fan tray to the mainframe.

## Individual Fans

You will need a screwdriver with a size T-15 Torx tip, a Philips screwdriver, pliers, a side cutter, and a scribe or jeweler's screwdriver or other small, pointed tool to perform this procedure.

**Removal** Use the following procedure to remove an individual fan from the rear chassis fan tray:

1. Do the *Rear Chassis Fan Tray* removal procedure, page 4–26.
2. Remove the screw that secures the hold down brackets to the rear chassis fan tray. (See Figure 4–13 on page 4–29.) If you are replacing one of the two fans nearest the cable connector, you need remove only one of the hold-down brackets. Otherwise, remove two.
3. Use the pliers to gently straighten the metal tabs holding the fan to the rear chassis fan tray.
4. Lift the fan from the rear chassis fan tray.
5. Make note of the fan cable dress and remove the tie holding the cables together near the connector. Remove the cable tie(s) if necessary.
6. Remove the fan wires from the cable connector. (Pay attention to the wire color locations for reinstallation.) Use a scribe or jeweler's screwdriver to gently push down the "finger" of metal that secures (latches) the wire end into the connector. (See insert, Figure 4–13 on page 4–29.) At the same time, pull gently on the wire until it comes out of the connector.

**Installation** Use the following procedure to reinstall the individual fans from the rear chassis fan tray:

1. Reinsert the fan wires into the cable connector. Be sure to insert the (color-coded) wires into the same locations as they were removed from in step 6, above. The "finger" of metal that secures the wire end into the connector should be pointed up and outward for it to lock into place. (See insert, Figure 4–13 on page 4–29.)
2. Position the fan onto the rear chassis fan tray.
3. Gather the fan cables together, tie them together with a cable tie, and position them so that they do not interfere with any fan blades.
4. Use a pair of pliers to gently bend the metal tabs that hold the fan to the rear chassis fan tray until the fan is held firmly in position.

- 5. Attach the hold-down bracket(s) to the rear chassis fan tray.
- 6. Do the *Rear Chassis Fan Tray* installation procedure, page 4-27.

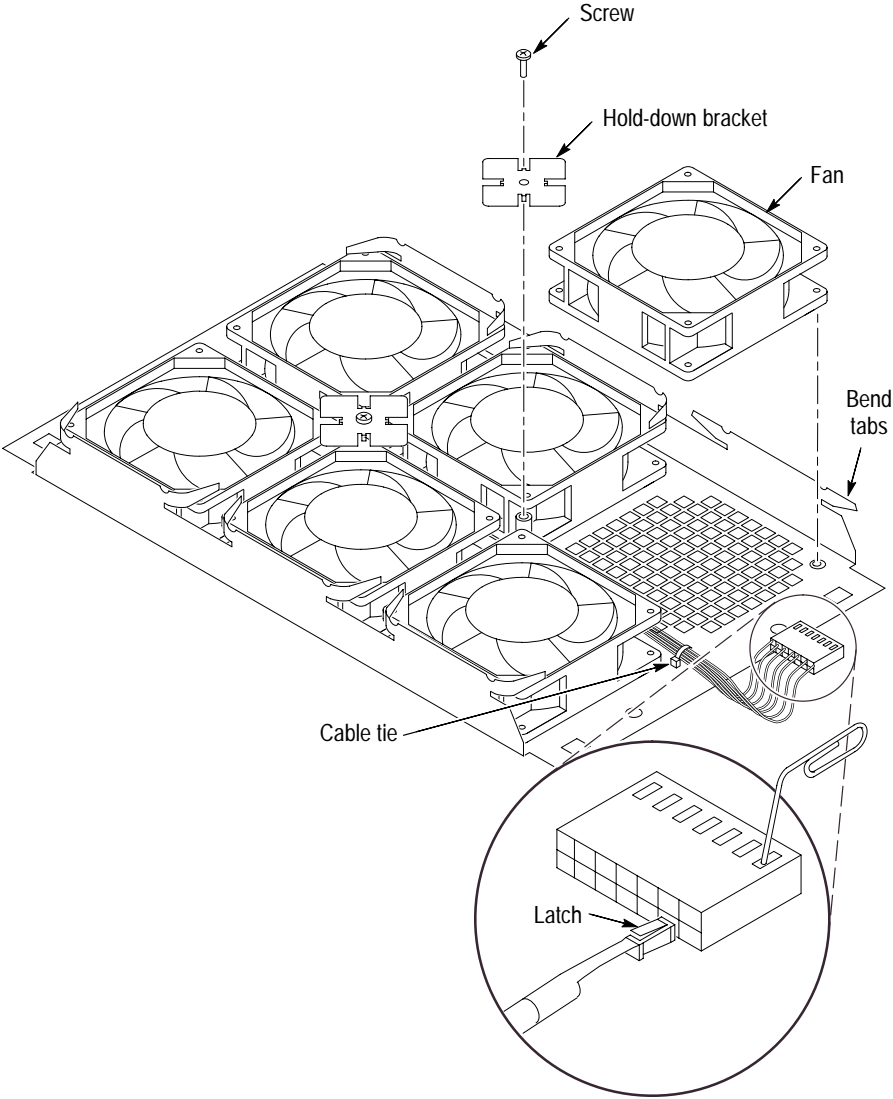

Figure 4-13: Individual fan removal

## Flip Stands and Rear Feet

You will need a screwdriver with a size T-15 Torx tip and a small Philips screwdriver to perform this procedure.

**Removal** Use the following procedure to remove the flip stands and rear feet:

1. Set the mainframe so the rear panel is on the work surface and the bottom faces you.
2. Do the *Bottom Cover* removal procedure, page 4–19.
3. Remove the two screws attaching the flip stand or rear foot to the bottom cover. (See Figure 4–14 on page 4–30.)

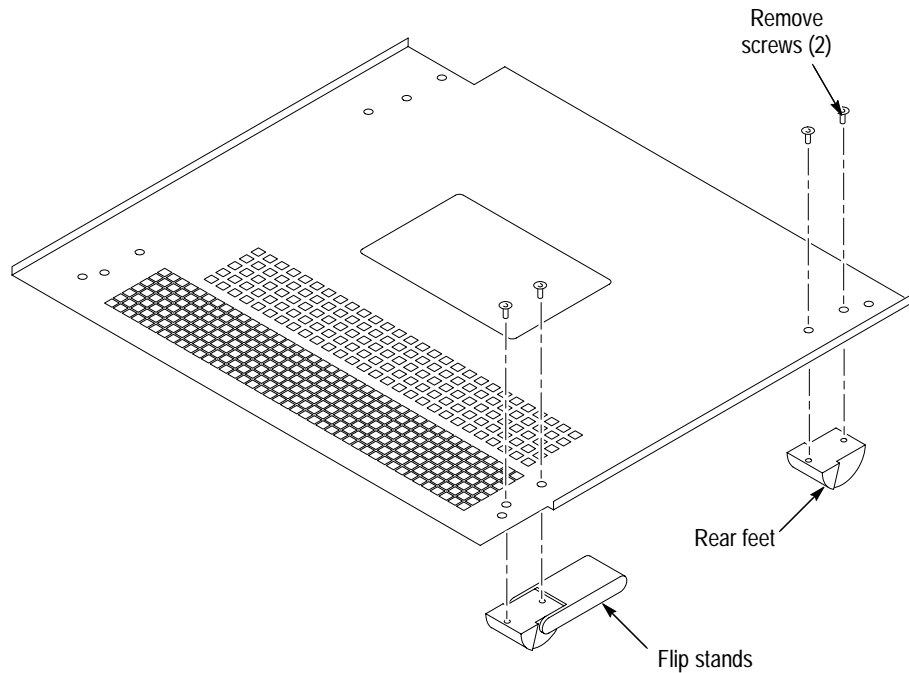

**Figure 4–14: Flip stand and rear feet removal**

**Installation** Reattach the flip stand or rear foot to the bottom cover. Do the *Bottom Cover* installation procedure as shown on page 4–19.

## Cord Wrap Feet

You will need a screwdriver with a size T-15 Torx tip to perform this procedure.

**Removal** Use the following procedure to remove the cord-wrap feet:

1. Set the mainframe so the bottom is on the work surface and the rear panel faces you.
2. Do the *Rear Chassis Fan Tray* removal procedure, page 4-26.
3. Orient the chassis fan tray so that the cord-wrap feet are on the bottom and the fans are on the top.
4. Press outward to unlatch the two tabs that connect each cord-wrap foot to the chassis fan tray. (See Figure 4-15 on page 4-31.)
5. Remove the cord-wrap feet.

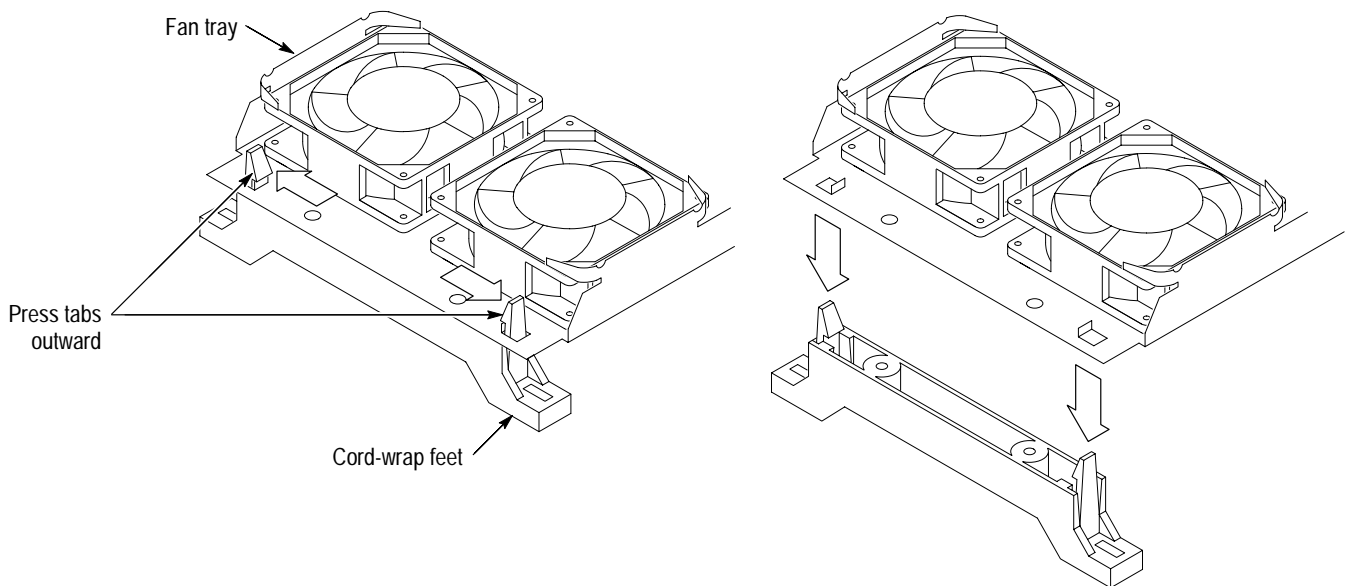

Figure 4-15: Cord-wrap feet removal

**Installation** Push the cord-wrap feet into the holes in the rear chassis fan tray to snap them into position. Do the *Rear Chassis Fan Tray* installation procedure as shown on page 4-27.

## Handle

You will need a screwdriver with a size T-15 Torx tip and a small flat-bladed screwdriver to allow you to remove the front panel trim ring prior to removing the handle.

**Removal** Set the mainframe so the bottom is on the work surface and the right side (the side with the handle) faces you.

Do the *Right Side Cover* removal procedure, page 4-22.

Remove the two inner screws connecting the handle to the power supply. (See Figure 4-16 on page 4-32) and then lift off the plastic handle mount and handle.

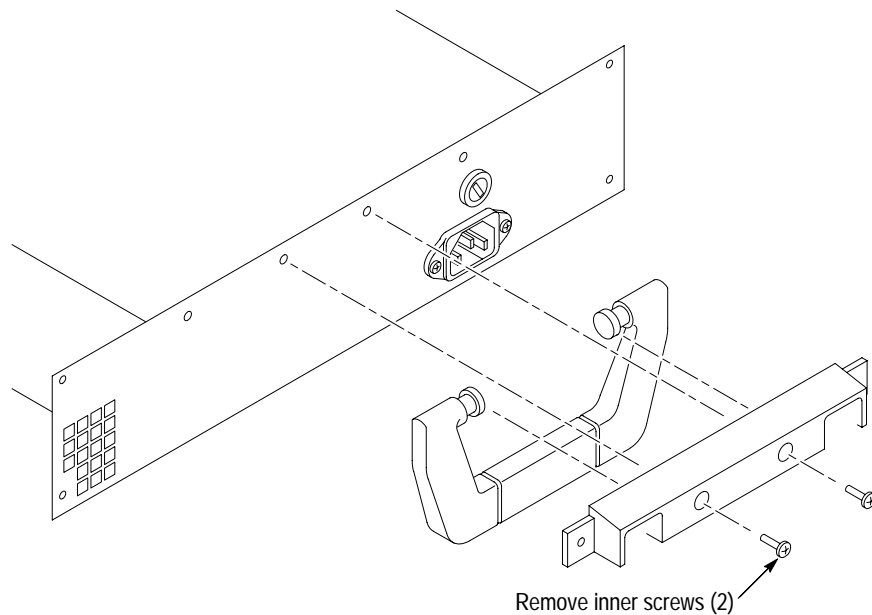

**Figure 4-16: Handle removal**

**Installation** Attach the handle and plastic handle mount to the power supply. Do the *Right Side Cover* installation procedure as shown on page 4-22.

## Procedures for Internal Parts

Figure 4–17 on page 4–34 shows the locations of the internal parts of the portable mainframe. Procedures for removing and replacing these parts are presented in the following order:

- Controller board
- SO DIMMs (RAM)
- Backplane board
- Front panel control board
- Front Panel interface board
- Glidepoint Assembly and Elastomeric Keypad

## Controller Board

You will need a screwdriver with a size T-15 Torx tip to perform this procedure.

### Removal

Use the following procedure to remove the controller board:

1. Locate the controller board in the locator diagram *Internal parts*, Figure 4–17 on page 4–34.
2. Set the mainframe so the bottom is on the work surface and the left side faces you.
3. Do the *Left Side Cover* removal procedure, page 4–21.
4. Remove the eight screws securing the EMI shield to the chassis (see Figure 4–17 on page 4–34), and then lift off the EMI shield.
5. Detach the three cables located near the bottom front corner of the controller board.
6. Remove the center screw from the controller board.
7. Remove the two screws securing the controller board to the chassis at the back panel.
8. Pull firmly on the rear panel until the controller board disconnects from the backplane board.

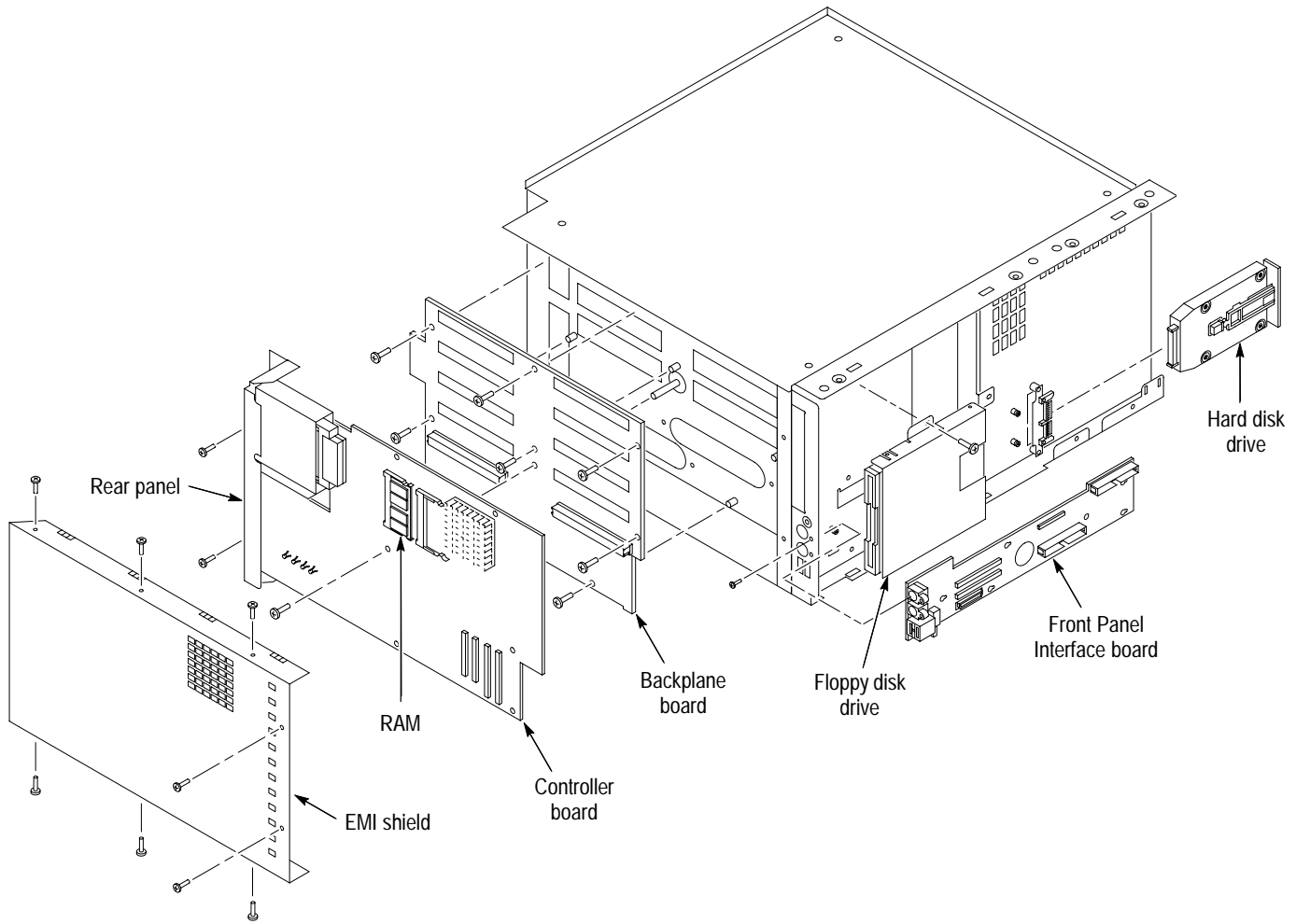

Figure 4-17: Internal parts

**Installation**

Use the following procedure to reinstall the controller board:

1. Reposition the controller board, and then push firmly on the backplane bus connector until the board is fully seated in the connectors on the backplane board.
2. Insert the center screw into the controller board.
3. Insert the two screws securing the controller board to the chassis at the back panel.
4. Reattach the three cables located near the bottom front corner of the controller board.
5. Reposition the EMI shield, and then insert the eight screws that secure it to the chassis.



6. Do the *Left Side Cover* installation procedure, page 4–22.

Refer to the *TLA 700 Series Performance Verification and Adjustment* manual for post-repair calibration procedures.

## Main Memory

You will need a screwdriver with a size T-15 Torx tip to perform this procedure.

### Removal

Use the following procedure to remove the RAM:

1. Locate the SO DIMM module in the locator diagram *Internal parts*, Figure 4–17 on page 4–34.
2. Set the mainframe so the bottom is on the work surface and the left side faces you.
3. Do the *Left Side Cover* removal procedure, page 4–21.
4. Remove the two screws securing the EMI shield to the chassis, and then lift off the EMI shield.
5. Press outward on the clips holding each SO DIMM module to the controller board, and then lift off the module board.

### Installation

Use the following procedure to install new SO DIMM module(s):



---

**CAUTION.** *SO DIMM modules must have gold plated contacts.*

*Use of SO DIMM modules that do not have gold plated contacts will result in eventual failure of the SO DIMM module.*

*Always use SO DIMM modules with gold plated contacts.*

---

1. Insert the new SO DIMM module. Press down gently until the clips that hold the modules to the controller board snap into place.
2. Reposition the EMI shield, and then insert the two screws that secure it to the chassis.
3. Do the *Left Side Cover* installation procedure, page 4–22.

## Backplane Board

You will need a screwdriver with a size T-15 Torx tip to perform this procedure.

**Removal** Use the following procedure to remove the backplane board:

1. Remove all modules installed in the portable mainframe.
2. Locate the backplane board in the locator diagram *Internal parts*, Figure 4-17 on page 4-34.
3. Do the *Controller Board* removal procedure, page 4-33.
4. Remove the seven remaining screws that secure the backplane board to the chassis.
5. Pull on the edges of the board nearest the front and rear surfaces of the mainframe to remove the backplane board from the chassis.
6. Detach cable J500.

**Installation** Use the following procedure to reinstall the backplane board:

1. Reattach cable J500.
2. Reposition the backplane board, and insert the screws that secure the backplane board to the chassis.
3. Do the *Controller Board* installation procedure, page 4-34.
4. Reinstall any modules removed from the portable mainframe.

## Front Panel Control Board

You will need a screwdriver with a size T-15 Torx tip and a flat-bladed screwdriver or other small prying tool to perform this procedure.

**Removal** Use the following procedure to remove the front panel control board:

1. Locate the front panel control board in the locator diagram *Front panel control assembly parts locations*, Figure 4-18 on page 4-37.
2. Do the *Front Panel Control Assembly* removal procedure (page 4-15).
3. Remove the knobs from the front of the front panel control assembly.
4. Detach the glidepoint cable at J100.

- 5. Remove the six screws that attach the front panel control board to the front panel control assembly.

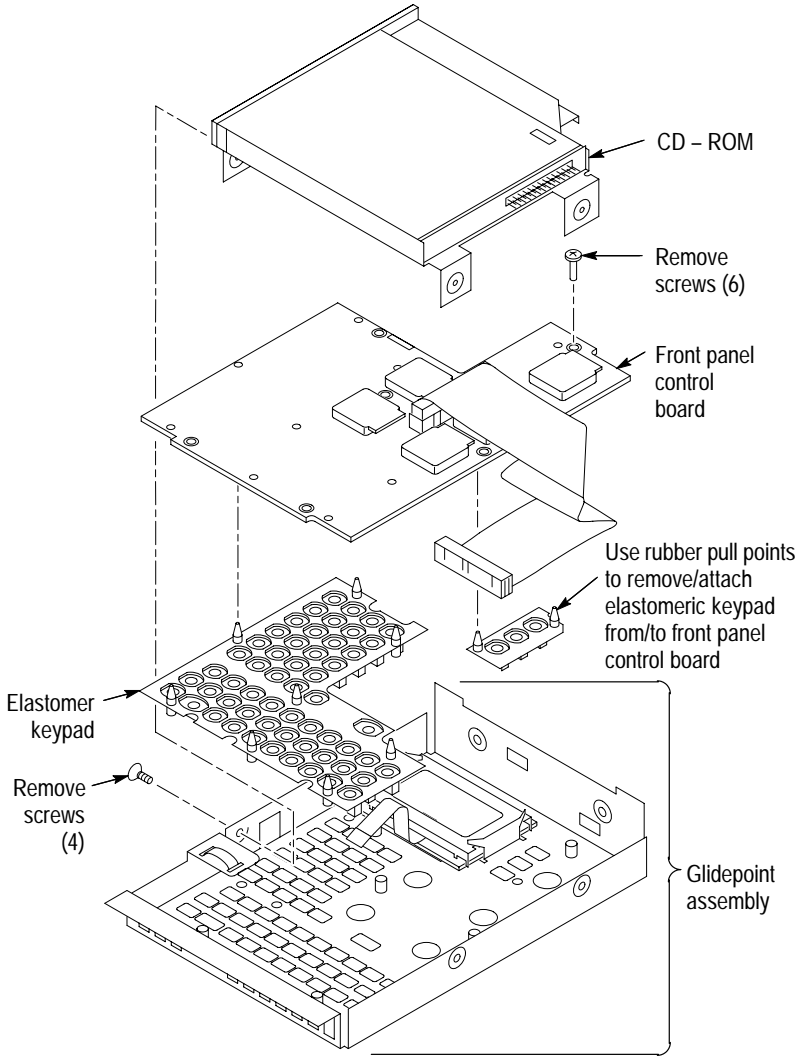

Figure 4-18: Front panel control assembly parts locations

- 6. Gently use the prying tool in the slots on the top and bottom of the control assembly to work the control board free.
- 7. Lift the front panel control board out of the assembly.

**Installation** Use the following procedure to reinstall the front panel control board:

1. Carefully work the control board into position, making sure that all keys go through their holes in the front panel and that the board is firmly seated.
2. Insert the six screws that attach the front panel control board to the front panel control assembly.
3. Reattach the glidepoint cable at J100.
4. Replace the knobs on the front panel.
5. Do the *Front Panel Control Assembly* installation procedure on page 4–17.

## Glidepoint Assembly

The glidepoint device is replaced as part of a larger assembly, consisting of the glidepoint device, glidepoint cable, front panel controls frame, and glidepoint bracket.

You will need a screwdriver with a size T-15 Torx tip to perform this procedure.

**Removal** Use the following procedure to remove the glidepoint assembly:

1. Locate the glidepoint assembly in the locator diagram *Front panel control assembly parts locations*, Figure 4–18, page 4–37.
2. Do the *Front Panel Control Assembly* removal procedure on page 4–15.
3. Do the *Front Panel Control Board* removal procedure on page 4–36.

**Installation** Use the following procedure to reinstall the glidepoint assembly:

1. Lay the glidepoint assembly face down on the work surface.
2. Do the *Front Panel Control Assembly* installation procedure on page 4–17.
3. Do the *Trim Ring* installation on page 4–11.

## Elastomeric Keypad

You will need a screwdriver with a size T-15 Torx tip to perform this procedure.

### Removal

Use the following procedure to remove the elastomeric keypad:

1. Locate the keypad in the locator diagram *Front panel control assembly parts locations*, Figure 4-18 on page 4-37.
2. Do the *Front Panel Control Assembly* removal procedure on page 4-15.
3. Do the *Front Panel Control Board* removal procedure on page 4-36.
4. Pull on the rubber pull-points from the front to remove the keypad from the Front Panel Control Board.

### Installation

Use the following procedure to reinstall the keypad:

1. Pull the rubber pull-points through the Front Panel Control Board to install the keypad.

---

**NOTE.** *When replacing the top three keys next to the glidepoint assembly, the rubber of the keypad should line up with the edge of the board.*

---

2. Do the *Front Panel Control Board* installation procedure.
3. Do the *Front Panel Control Assembly* installation procedure.
4. Do the *Trim Ring* installation on page 4-11.



# Fixed Hard Disk Drive Removal and Installation

These instructions direct you to remove or install a fixed hard disk drive. A fixed hard disk drive is available through the TLA 7UP mainframe upgrade kit. Contact your Tektronix representative for more information.

Prior to performing these procedures, use the Windows Back Up tool to back up any user files stored on the present hard disk drive. Use the backup media that was shipped with the instrument to reinstall the operating system and applications.

For further information on software backup and installation, refer to the *TLA 714 and TLA 720 Logic Analyzer Installation Manual*.

These instructions assume that you are familiar with servicing the instrument.

Contact your nearest Tektronix, Inc., Service Center or Tektronix Factory Service Center for installation assistance.



---

**CAUTION.** *To prevent static discharge damage, service the instrument only in a static-free environment.*

*Observe standard handling precautions for static-sensitive devices while installing this kit.*

*Always wear a grounded wrist strap, grounded foot strap, and static-resistant apparel while installing this kit.*

---

These instructions must be performed in the sequence in which they are presented; they include the following procedures:

- *Disassembly*, which removes the external parts needed to access the location for the fixed hard disk drive inside the portable mainframe.
- *Fixed Hard Disk Drive Installation*, to install the fixed hard disk drive.
- *Reassembly*, which reinstalls parts removed in *Disassembly*.

This section contains procedures for removal and installation of all mechanical and electrical field-replaceable parts.

## Preparation



---

**WARNING.** Before performing this or any other procedure in this manual, read the Safety Summary found at the beginning of this manual.

---



---

**WARNING.** Dangerous voltages may be present.

Before performing any procedure in this subsection, disconnect the power cord from the line voltage source.

Failure to do so could cause serious injury or death.

---

## General Instructions

---

**NOTE.** Read the following general instructions before removing a part.

Following these instructions helps ensure that you remove the part to be serviced while removing the minimum number of additional parts.

---

## Tools Required

You will need the following tools to perform this procedure:

- Screwdriver with a T-15 Torx tip
- Screwdriver with a T-10 Torx tip
- Flat Blade Screwdriver
- Phillips screwdriver with a #1 tip



## Remove Hard Disk Drive From The Cartridge

If the hard disk drive you are installing is not a replaceable type, but rather a fixed hard disk drive, the hard disk drive must be removed from inside of the removable hard disk drive cartridge that was received with this kit.

Refer to Figure 4–19 and follow these steps:

1. Remove the four screws that fasten the hard disk drive to the cartridge.
2. Carefully remove the hard disk drive from the cartridge, and remove the cable assembly from the connector on the hard disk drive.

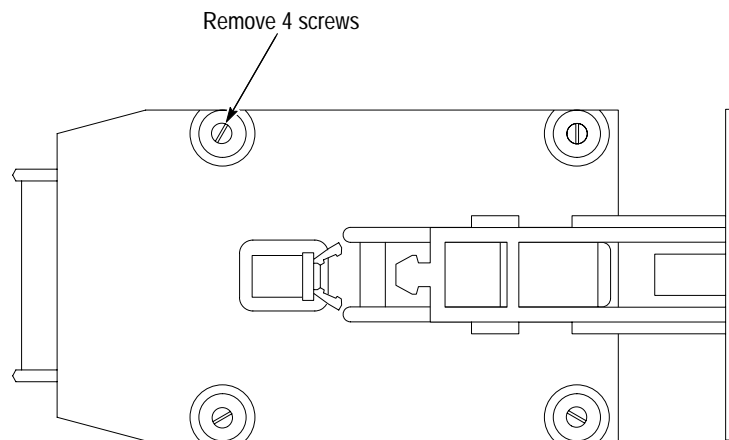

**Figure 4–19: Removing the hard disk drive from the cartridge**

## Removing the Replaceable Hard Disk Drive

Verify that the chassis is powered down.

The replaceable hard disk drive cartridge is removed by depressing it to release the latch.

Pull on the replaceable hard disk drive cartridge to remove it from the chassis. Refer to Figure 4-20, 4-21 and 4-22.

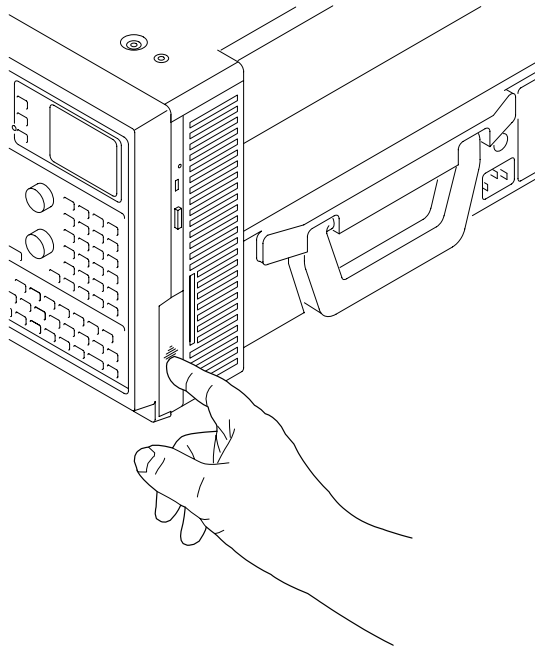

**Figure 4-20: Depress the latch**

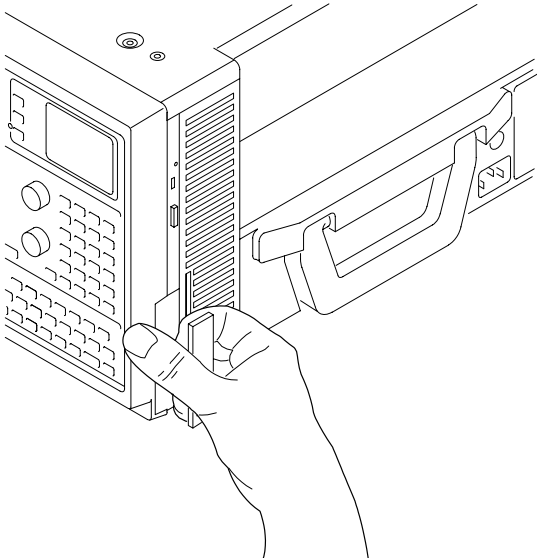

Figure 4-21: Unlatching the hard disk drive cartridge

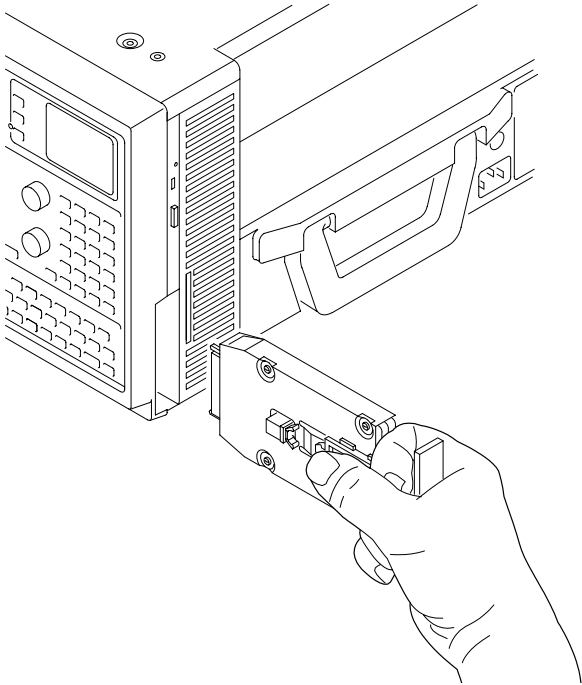

Figure 4-22: Removing the hard disk drive cartridge

## Remove the Trim Ring

You will need a flat-bladed screwdriver (or other small prying tool) to remove the trim ring.

**Removal** Use the following procedure to remove the trim ring:

1. Set the mainframe with the cord-wrap feet on the work surface and the bottom facing you.
2. Grasp the trim ring by its bottom edge and pull toward you to detach the three plastic snaps. (Alternatively, you can use a flat-bladed screwdriver or other small prying tool to help you detach the snaps.) Then, swing the bottom of the ring upward and work the rest of the ring off the front panel.

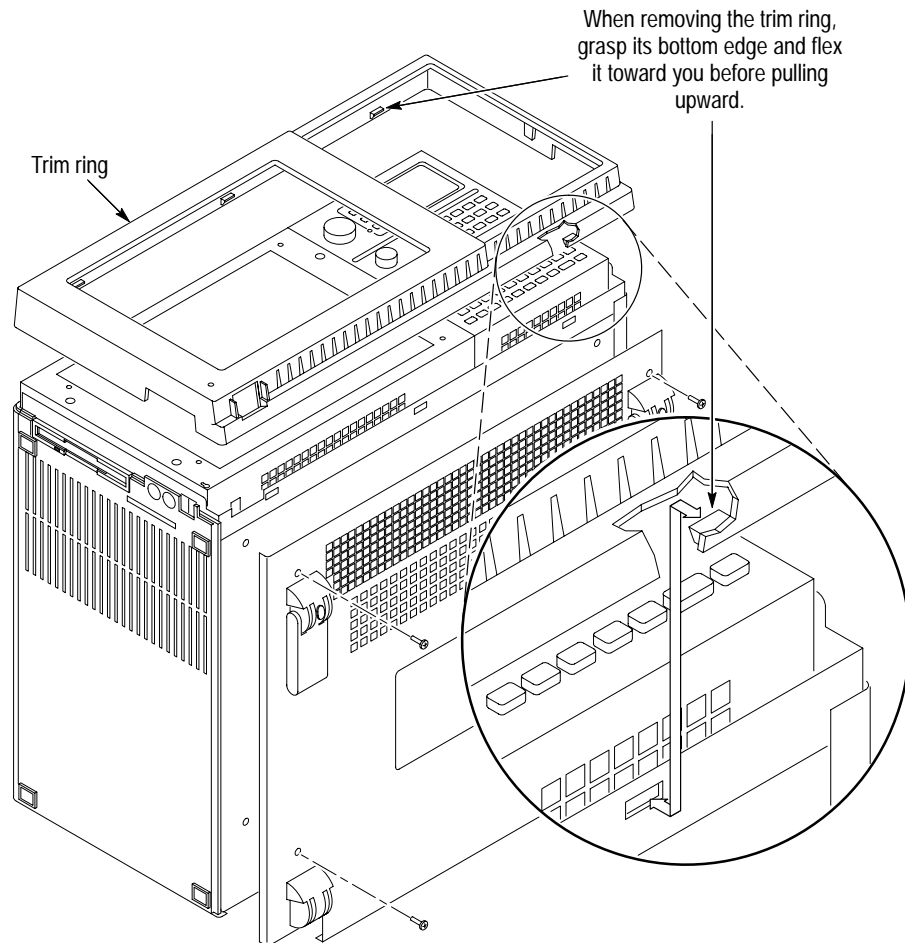

Figure 4-23: Front cover and trim ring removal

## Remove Flat Panel Display Assembly

You will need a screwdriver with a size T-15 Torx tip to perform this procedure.

**Removal** Use the following procedure to remove the flat panel display assembly:

1. Remove the five screws that attach the flat panel display assembly to the mainframe: two screws at the bottom of the assembly on the front of the instrument, two screws on the top, and one screw on the left side. (See Figure 4–24).
2. Lift the bottom edge of the flat panel display assembly and rotate it upward and off the front face of the mainframe.
3. Detach the cable connecting the flat panel display assembly to connector J209 on the front panel interface board.

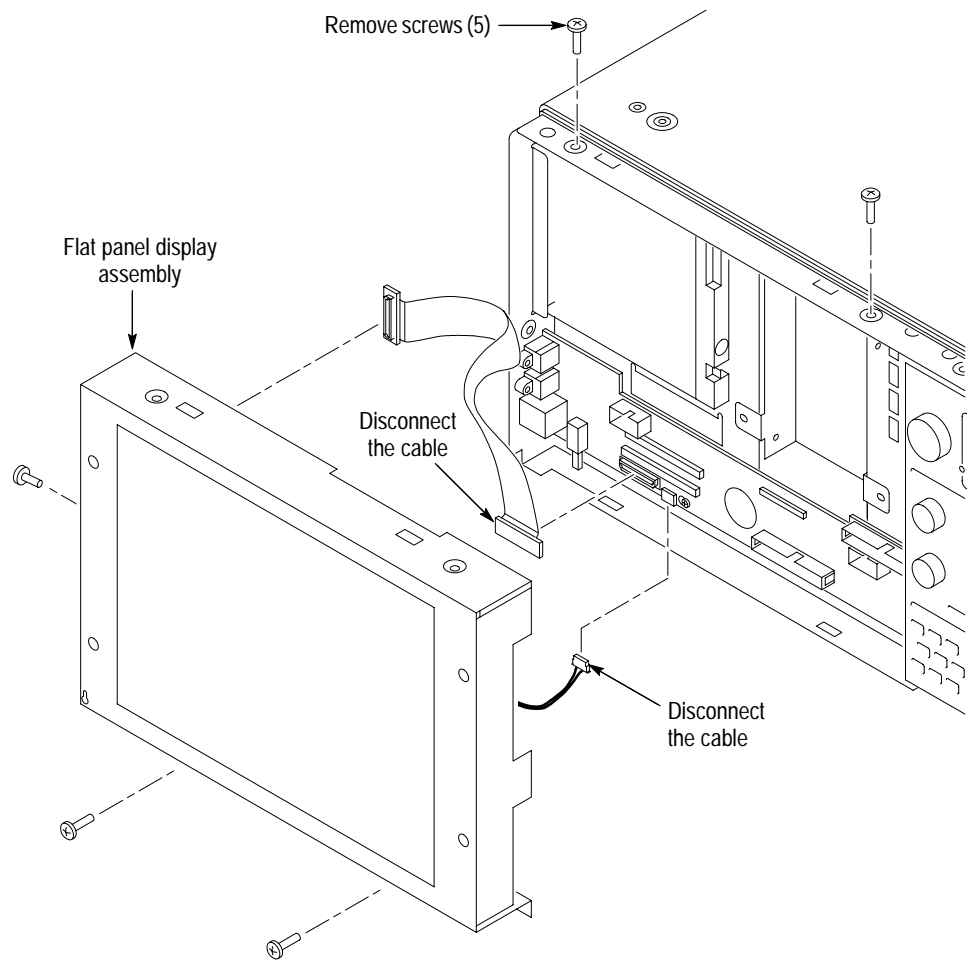

**Figure 4-24: Flat panel display assembly removal**

## Install Fixed Hard Disk Drive

You will need a screwdriver with a size T-15 Torx tip to perform this procedure.

**Installing** Use the following procedure to install the fixed hard disk drive:

1. Determine if you want the fixed hard disk drive to be the master or slave drive.  
  
If you want the fixed hard disk drive to be the master drive, skip step 2 and go to step 3.
2. Place a shorting jumper on the hard disk drive to make it the slave drive as shown in the *TLA 7UP Mainframe Field Upgrade Kit Instruction Manual*.
3. Remove the fixed hard disk drive bracket from the chassis as in Figure 4-25.
4. Attach the data cable to the fixed hard disk drive.
5. Position the fixed hard disk drive and attach the fixed hard disk drive to the bracket with the screws included with this kit as shown in figure 4-25.

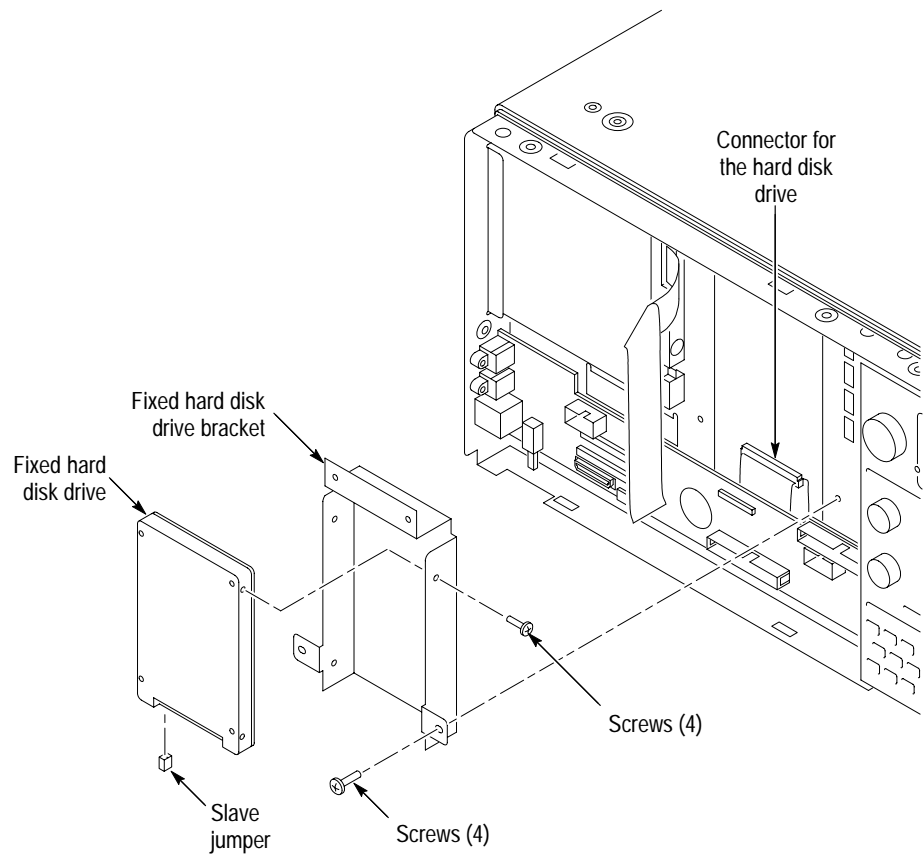

**Figure 4-25: Installing the fixed hard disk drive**

6. Do the *Flat Panel Display Assembly* procedure.
7. Do the *Trim Ring Installation* on page 4-51.



## Install Flat Panel Display Assembly

You will need a screwdriver with a size T-15 Torx tip to perform this procedure.

**Installation** Use the following procedure to reinstall the flat panel display assembly:

1. Reattach the cable connecting the flat panel display assembly to the interface board.
2. Reinstall the flat panel display assembly by first inserting the top edge and then rotating it downward into position. (Be sure the tabs are engaged at the top of the assembly. Insert the five screws that attach the flat panel display assembly to the mainframe: two screws at the bottom of the assembly on the front of the instrument, two screws on the top, and one screw on the left side. (See Figure 4–24).

## Install the Trim Ring

To install the trim ring follow these instructions.

**Installation** Use the following procedure to replace the trim ring:

3. Replace the trim ring on the front panel. Start at the top edge and work around to the bottom until the three plastic snaps engage. Press the trim ring down all around the edges until it is completely seated.

## Verify Operation

Follow the steps below to ensure proper operation of the instrument:

1. Reinstall all software. For help on software installation, refer to the *TLA 700 Series Logic Analyzer Installation Manual*.
2. Run memory and hard disk drive verification tests from the QA+Win32 diagnostics.

---

**NOTE.** To run QA+Win32 you must have either a working keyboard or working mouse (or other pointing device) and Windows 98 running.

---

- a. Turn off all other applications and close all open windows.
- b. Click Start → Programs → QA+Win32
- c. Run the memory tests from the QA+Win32 menu. If needed, refer to the QA+Win32 online help for more information on running QA+Win32.



# Troubleshooting



---

**WARNING.** Before performing this or any other procedure in this manual, read the General Safety Summary and Service Safety Summary found at the beginning of this manual.

To prevent possible injury to service personnel or damage to electrical components, please read Preventing ESD on page 4-1.

---

This section contains information and procedures designed to help you isolate faults to within the portable mainframe. The process is as follows:

- Do *Check for Common Problems* on page 4-54 to eliminate easy-to-find problems first.
- Do *Eliminate Other Problem Sources* on page 4-56 to eliminate the probes and DSO or Logic Analyzer modules as the fault source next.
- Do *Troubleshoot the Portable Mainframe*, beginning on page 4-56, to locate the failed replaceable part within the mainframe.

For assistance, contact your local Tektronix Service Center.

## Service Level

This section supports isolation of faults within the portable mainframe to the replaceable-part level shown in Chapter 10. In most cases, faults are isolated to circuit boards or assemblies, but not to individual components on those boards. See *Strategy for Servicing* on page xiii.

## Check for Common Problems

Use Table 4–2 to quickly isolate possible failures. The table lists problems related to the portable mainframe and possible causes. The list is not exhaustive, but it may help you eliminate a problem that is quick to fix, such as a blown fuse or loose cable.

**Table 4–2: Failure symptoms and possible causes**

Symptom	Possible cause(s)
Portable mainframe will not power on	<ul style="list-style-type: none"> <li>■ Power cord not plugged in.</li> <li>■ Failed fuse.</li> <li>■ Faulty power supply.</li> <li>■ Faulty backplane board.</li> <li>■ Faulty module.</li> </ul>
Front panel light comes on (mainframe powers on), but one or more fans will not operate	<ul style="list-style-type: none"> <li>■ Faulty fan cable.</li> <li>■ Defective fan.</li> <li>■ Faulty power supply.</li> </ul>
Controller appears “dead”; power light comes on, but monitor screen(s) is (are) blank, mainframe emits no beeps	<ul style="list-style-type: none"> <li>■ SO DIMMs incorrectly installed or missing.</li> <li>■ Defective controller board.</li> </ul>
External monitor does not power on	<ul style="list-style-type: none"> <li>■ Monitor power cord not plugged in.</li> <li>■ Failed fuse.</li> <li>■ Monitor failure.</li> </ul>
External monitor powers on, but is blank	<ul style="list-style-type: none"> <li>■ External monitor controls turned down.</li> <li>■ Monitor cable faulty or not connected to mainframe.</li> <li>■ Monitor defective.</li> </ul>
Hard disk drive related symptoms	<ul style="list-style-type: none"> <li>■ Defective hard disk drive.</li> <li>■ Incorrect hard disk type selected in the BIOS setup.</li> <li>■ Replaceable hard disk drive not installed.</li> <li>■ Benchtop chassis power supply failure, refer to the <i>TLA 720 Benchtop Chassis Service Manual</i> for troubleshooting procedures.</li> <li>■ Corrupted controller BIOS module firmware, reinstall firmware. Refer to <i>Upgrading Module Firmware</i> in the <i>TLA 714 and TLA 720 Installation Manual</i>.</li> <li>■ Controller BIOS setup problem. See BIOS Settings.</li> <li>■ Replaceable hard disk drive or optionally field installed fixed hard disk drive not configured as bootable (slave) master hard disk drive.</li> <li>■ Faulty benchtop controller.</li> </ul>

**Table 4-2: Failure symptoms and possible causes (Cont.)**

Symptom	Possible cause(s)
CD-ROM related symptoms	<ul style="list-style-type: none"> <li>■ Defective CD-ROM.</li> <li>■ Defective CD-ROM drive cable.</li> <li>■ Defective CD-ROM board.</li> <li>■ Incorrect CD-ROM configuration in the BIOS setup.</li> </ul>
Flat panel display blank	<ul style="list-style-type: none"> <li>■ Display selection jumper set incorrectly on front panel interface board (there are no jumpers on the board when the mainframe is shipped from the factory; this is the correct default setting).</li> <li>■ External monitor plugged in (look on external monitor for display).</li> <li>■ External monitor plugged in but not powered on.</li> <li>■ Defective cable from front panel interface board to display adapter board.</li> <li>■ Defective cable from controller board to front panel interface board.</li> <li>■ Defective cable from inverter board to display adapter board.</li> <li>■ Defective cable from inverter board to backlighting display lamp.</li> <li>■ Defective backlighting display lamp.</li> <li>■ Faulty display.</li> <li>■ Faulty controller board.</li> <li>■ Faulty inverter board.</li> <li>■ Faulty front panel interface board.</li> </ul>
Modules not recognized	<ul style="list-style-type: none"> <li>■ Module firmware incompatible with mainframe software version. Refer to the <i>TLA 714 and TLA 720 Installation Manual</i> for software and module firmware update instructions.</li> <li>■ TLA 700 system problem. Execute the internal resource manager program to determine if the mainframe recognizes any installed modules. Refer to instructions on page 4-62.</li> <li>■ Faulty module. Refer to appropriate module service manual for further troubleshooting information.</li> <li>■ Flash jumper installed on module.</li> </ul>
BIOS error messages	<ul style="list-style-type: none"> <li>■ Refer to the BIOS error message table on page 4-65.</li> </ul>

## Eliminate Other Problem Sources

The portable mainframe is part of the TLA 700 Series Logic Analyzer, which comprises modules and the portable mainframe. If power-on diagnostics indicate that an LA or DSO module test failed, troubleshoot the module using the TLA service manual for the module.

## Troubleshoot the Portable Mainframe

Follow the procedure in this section to identify the failed part within the portable mainframe.

## Equipment Required

You will need a digital voltmeter to check power supply voltages, as described on page 4–60.

Testing might also be required to correct some faults. Under those circumstances, you will need the test equipment listed in the *TLA 700 Series Performance Verification and Adjustment Procedures* manual.

## Fault Isolation Procedure

Follow the primary troubleshooting tree in Figure 4–26 for fault isolation. This tree calls for you to remove any installed modules, run the diagnostics programs, and check for BIOS errors.

If you are unable to identify any problems through the troubleshooting tree or through the diagnostic programs refer to *Isolating System Problems* beginning on page 4–62 for further troubleshooting information.

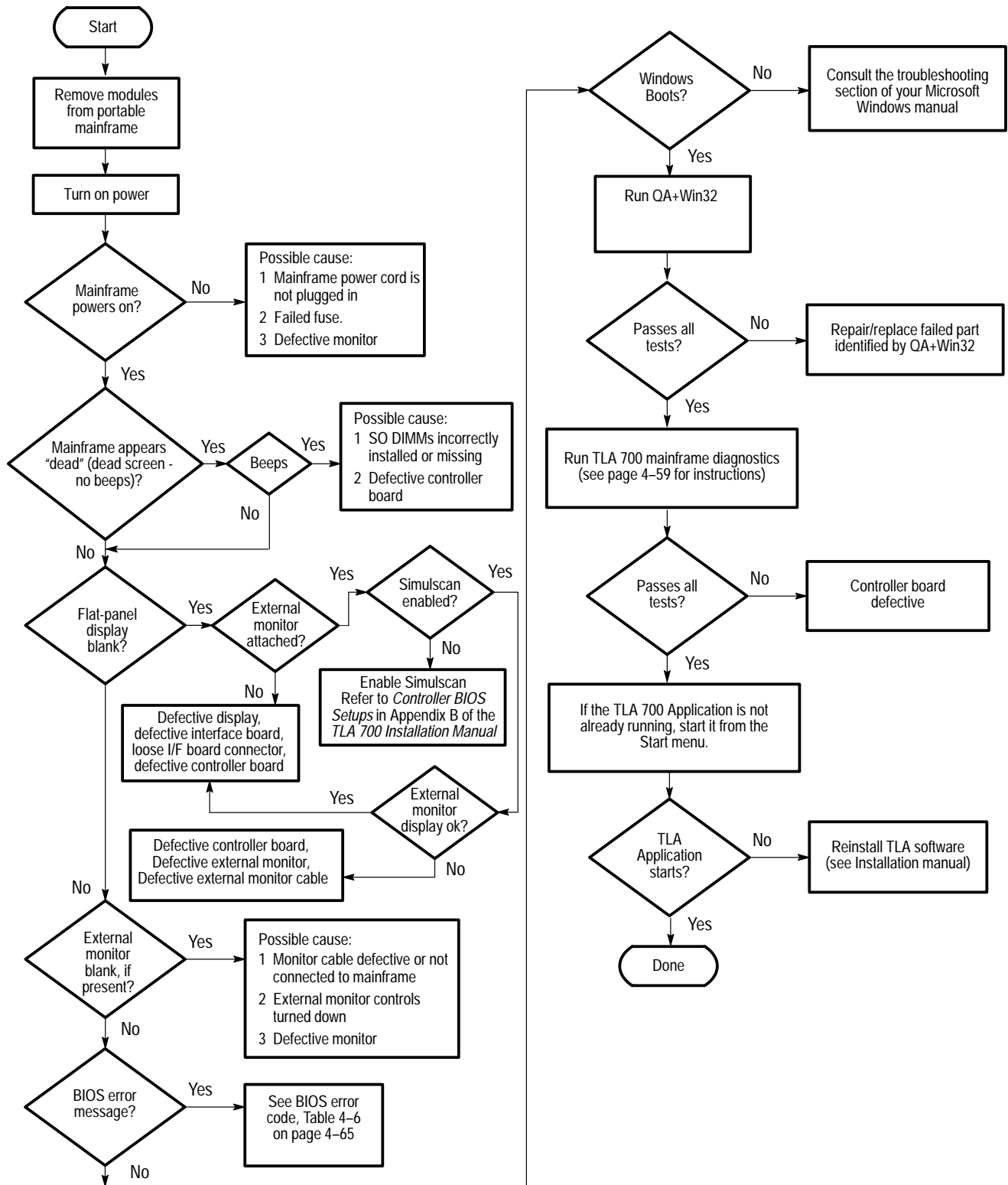

Figure 4-26: Primary troubleshooting tree

## Controller and PC Diagnostics

The primary diagnostics for the portable mainframe are the power-on diagnostics, the QA+Win32 diagnostics, and the TLA 700 mainframe diagnostics. Procedures for running these diagnostics are described below.

### Power-On Diagnostics

The power-on diagnostics check the basic functionality of the portable mainframe at every power on. If any failures occur at power on, the screen displays the calibration and diagnostics property page. Table 4–3 lists a subset of the power on tests. Use the results of the tests to help you isolate problems to the portable mainframe or to the modules installed in the system.

The power on tests ensure that hardware is installed and can be accessed by the software. The tests do not provide any performance information, but they provide limited diagnostic information. The TLA 700 mainframe diagnostics provide more extensive tests than the power-on diagnostics.

The power on tests check the generic hardware including the keyboard, mouse, memory, CPU, and associated peripherals. The interrupt lines and trigger lines are tested for each installed application module.

If there are no failures, you can view the results of the tests in the Calibration and Diagnostics page under the System menu. To view the Extended diagnostics, click on the Extended tab.

**Table 4–3: TLA 700 Power-on diagnostic tests**

Component	Group & test	Power on	Extended
TLA 700 mainframe	VTC Reset Test	✓	
	VTC Walk1 Test	✓	
	ADG Register Test	✓	
	ADG VXI Addr Test	✓	
	ADG VXI Data Test	✓	
TLA 700 system	Interrupt Lines	✓	✓
	Trigger Lines	✓	✓



## QA+Win32

If the portable mainframe passes all the BIOS tests, the primary tree calls for you to run QA+Win32 diagnostics software.

QA+Win32 is a comprehensive diagnostic software application to check and verify the operation of the PC hardware in the portable mainframe.

To run QA+Win32, you must have either a working keyboard or a working mouse or other pointing device and have the Windows operating system running. Repair or replace any failed component identified by QA+Win32.

---

**NOTE.** *To run QA+Win32 you must have either a working keyboard or a working mouse (or other pointing device) and Windows running.*

---

To run the QA+Win32 diagnostic software, do the following steps:

1. Turn off all other applications and exit all windows.
2. Click Start → Programs → QA+Win32 → QA Win32.
3. Reboot the mainframe after QA+Win32 diagnostic tests to restore the mainframe to normal operating condition.

**TLA 700 Mainframe Diagnostics.** If the portable mainframe passes all the QA+Win32 tests, the primary tree calls for you to run the TLA 700 Mainframe Diagnostics. The TLA 700 Mainframe Diagnostics are a comprehensive software test that checks the functionality of the portable mainframe. If the TLA 700 Mainframe Diagnostics test fails, the portable mainframe is defective.

To run the TLA Mainframe Diagnostics, do the following steps:

1. Turn off all other applications.
2. Click on Start in the Windows tool bar.
3. Select Programs from the Start menu.
4. Select Tektronix TLA 700 from the Programs menu.
5. Select TLA 700 Mainframe Diagnostics from the Tektronix TLA 700 menu.

## Bypassing Front Panel Controls

The front panel control assembly can be bypassed if necessary to assist in troubleshooting. Bypassing the front panel control assembly allows an external keyboard and mouse to function bypass the front panel control board as in a standard PC.

To bypass the front panel control assembly, unplug the cable from it to the front panel interface board (located behind the flat-panel display) at J102. Then, use jumpers to connect pins 33 and 34, pins 31 and 32, pins 27 and 28, and pins 25 and 26. See Figure 4-27.

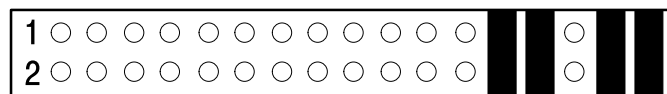

J102

**Figure 4-27: Jumper locations for bypassing front panel control assembly**

## Checking the Power Supply Voltages

Power off the mainframe and remove any modules installed in it. Power on the portable mainframe and connect the reference lead of a digital voltmeter to chassis ground, such as the top of the power supply.

Attach a 0.025 inch square pin to the probe tip of the other lead and insert it into a pin on one of the backplane connectors. The pins that should be carrying voltages are listed in Table 4-4.

The arrangement of J1 and J2 connectors on the backplane is shown in Figure 4-28 on page 4-62.

Measure the power supply voltages with the voltmeter and compare each reading to the values listed in the tables. If the voltages are within about 5% of the nominal voltages, your power supply is functional.

**Table 4-4: Power supply voltages and backplane connector pins**

J1 Pin	Voltage	J2 Pin	Voltage
Row A		Row A	
31	-12 V	2	-2 V
32	+5 V	7	-5.2 V
		13	-5.2 V
		19	-5.2 V
		25	+5 V
Row B		Row B	
32	+5 V	13	+5 V
		32	+5 V
Row C		Row C	
31	+12 V	4	-5.2 V
32	+5 V	13	-2 V
		19	-5.2 V
		31	+24 V
		32	-24 V

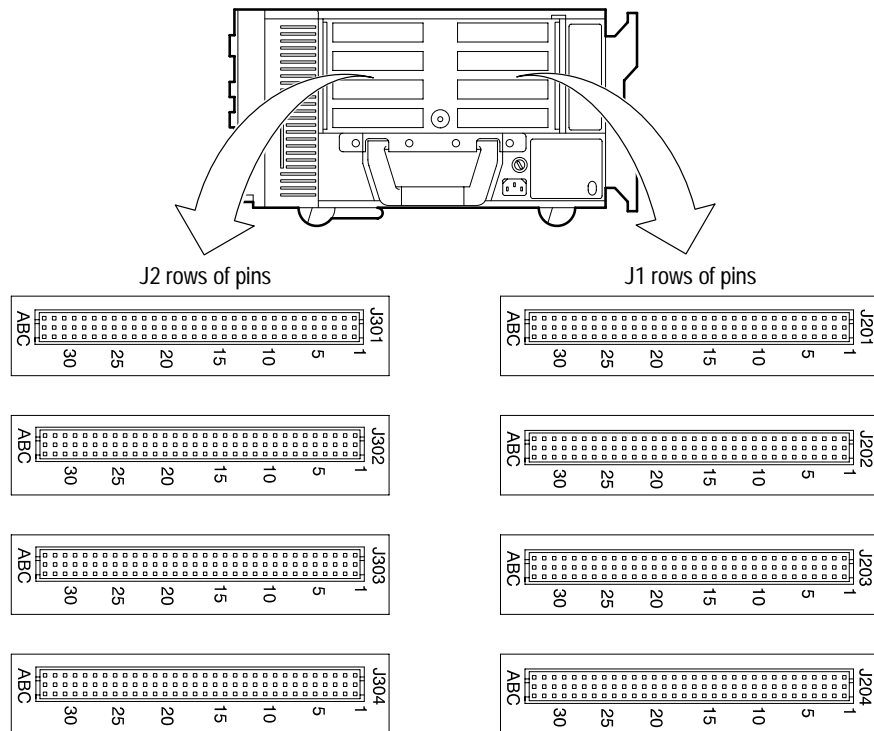

Figure 4-28: Location of J1 and J2 pins within the portable mainframe

## Isolating System Problems

If you have completed all of the troubleshooting procedures up to this point and the TLA 700 application fails to display any modules in the System Window, you may have a system problem. Check for the following:

- Verify that all modules are properly installed in the portable mainframe.
- Verify that the module address switches are set correctly. Power off the portable mainframe and remove the modules. Set the address switches to FF and reinstall the modules.
- Verify that the modules do not have the flash programming jumper installed on the rear of the module. Power off the portable mainframe and remove the modules. Remove the jumper and reinstall the modules.
- Try placing a suspected module in a different slot to verify slot dependency problems. For example, if you have a single module in slots 1 and 2, power off the portable mainframe, move the module to slots 3 and 4, and try the tests again. If the module works in the new location, you have identified a faulty slot in the mainframe.

- Check for broken connectors on the backplane, and broken connectors or bent pins on the module connectors.
- Faulty module. Replace the suspected faulty module with a known-good module, or contact your local Tektronix service center.
- Incompatible module firmware and portable mainframe software versions. Refer to the *TLA 700 Series Installation Manual* for software and module firmware update instructions.
- Check for computer viruses.

You can also execute the internal resource manager program (ResMan32.exe) to identify if any of the installed modules are being identified in the portable mainframe slots. Table 4-5 lists some of the command line options for executing ResMan32.

**Table 4-5: Command line options for ResMan32**

Option	Description
-a, -A, -o, -O	ResMan32 will not close the text window after executing and displaying the results the major functions (default).
-p, -P	ResMan32 will not execute the mainframe power-on self test diagnostics (default).
-v, -V	ResMan32 records the resource manager actions in the text window in a short form or nonverbose mode.
+a, +A, +o, +O	ResMan32 will terminate the tests and display the resultant action information in the text window.
+p, +P	ResMan32 will perform the mainframe power-on self test diagnostics.
+v, +V	ResMan32 records all actions in a text window in the verbose mode (default).
+t, +T	ResMan32 will not display the text window and the tests will terminate after executing regardless of the error conditions.
+m, +M	ResMan32 displays in a minimized window.

1. Quit the TLA 700 application and any other applications on the desktop.
2. Click on the Window Start button and select Run.
3. In the dialog box enter the following path:  
 C:\Program Files\TLA 700\System\ResMan32.exe
4. Click on OK.

The ResMan32 will check all of the installed modules and their address locations. The program will print out data similar to that in Figure 4–29. In this example the portable mainframe has two logic analyzer modules installed. Both modules were properly configured and the resources were successfully configured.

If ResMan32 encounters any errors (such as an unsupported instrument or application module), the resource manager will stop further communications and display information on why or at what point the instrument module was disabled.

```
#Resource Mgr
#09/09/97 08:48:49
Auto Exit - Off
Identify Static Configure Devices
    Found a device at LA 1
    Found a device at LA 2
Identify Dynamic Configure Devices
Matching Devices to Slots
    match la=1 to slot=1
    match la=2 to slot=3
Setting VISA Attributes
    la 1, slot 1: device_class 2, manf_id 0xffd, model_code 0x7f4, addr_spc 0
    la 2, slot 3: device_class 2, manf_id 0xffd, model_code 0x7f1, addr_spc 0
Setting VISA Address Maps
    A24 device @ la 1 - starting address 200000x, size 65536
    A24 device @ la 2 - starting address 210000x, size 65536
Enabling Events & Responses
    la 1: Int ID 1 assigned to IRQ 4
    Enabling Events: 16-32 124-125 127
    la 1: Asynchronous Enable succeeded
        **Responses are unsupported by this device
    la 2: Int ID 1 assigned to IRQ 4
    Enabling Events: 16-32 124-125 127
    la 2: Asynchronous Enable succeeded
        **Responses are unsupported by this device
Begin Normal Operation
    slot 1, LA 1, started successfully
    slot 3, LA 2, started successfully
VISA Data
    la_1=1,1,4093,2036,2,0,1,7,2097152
    la_2=2,3,4093,2033,2,0,1,7,2162688
```

**Figure 4–29: ResMan32 program output**

## BIOS Setup Error Messages

The portable mainframe runs a BIOS test when it boots up. If the BIOS test encounters a problem, the program displays the error on the display. Table 4–6 lists the error codes, an explanation of each error code, and actions that can be taken. Refer to the *TLA 700 Series Installation Manual* for information on BIOS setup parameters and feature settings.

**Table 4–6: BIOS error codes and explanations**

Error code	Explanation	Action to be taken
Diskette drive A error	<p>The BIOS test recognizes the presence of the floppy disk drive, but the floppy disk drive fails the power-on self-test.</p> <p>The floppy disk drive may be defined incorrectly in the CMOS setup.</p> <p>The floppy disk drive may not be connected correctly on the adapter board.</p>	<p>Verify the floppy disk drive is configured correctly in the CMOS setup.</p> <p>Verify that the floppy disk drive cable is connected on the floppy disk drive and the adapter board.</p>
Extended RAM Failed at offset: nnnn	The extended memory may not be configured correctly or the extended memory is defective at HEX address nnnn.	<p>Verify that the extended memory is configured correctly in the CMOS setup.</p> <p>Exchange the SO DIMMs. If one of the SO DIMMs is defective the error address should change.</p>
Failing Bits: nnnn	The RAM address mapped to HEX nnnn in the system, shadow, or extended memory has failed. A 1 in the map indicates a failed bit.	<p>Exchange the SO DIMMs.</p> <p>If one of the SO DIMMs is defective the error address should change.</p>
Fixed Disk 0 Failure  (or)  Fixed Disk Controller Failure	<p>The hard disk drive may not be defined correctly in the CMOS setup.</p> <p>The hard disk drive may not be connected correctly. The hard disk drive may be defective.</p> <p>Replaceable hard disk drive not installed.</p> <p>Replaceable hard disk drive may be jumpered as a slave, and there is not a master fixed hard disk drive present.</p>	<p>Verify the hard disk drive is configured correctly in the CMOS setup.</p> <p>Verify that the hard disk drive cable is connected on the hard disk drive and on the adapter board.</p> <p>Replace the hard disk drive and reinstall the TLA 700 Series software.</p>
Incorrect Drive A Type - run Setup	The floppy disk drive may not be defined correctly in the CMOS setup.	Verify the floppy disk drive is configured correctly in the CMOS setup.
Invalid NVRAM media type	The BIOS cannot access the NVRAM.	Replace the controller board.
Keyboard controller error	The keyboard controller may be defective.	Swap keyboard with a known good keyboard.
Keyboard error (Front panel keypad error)	<p>The keyboard may be missing or defective.</p> <p>Note: This error is quite uncommon because both the external keyboard and the front panel keypad would have to be missing or defective.</p>	Swap keyboard with a known good keyboard.

**Table 4–6: BIOS error codes and explanations (Cont.)**

Error code	Explanation	Action to be taken
Keyboard error nn	<p>There may be a stuck or defective key.</p> <p>The BIOS returns the address of the key where HEX nn is the address of the key.</p>	<p>Swap keyboard with a known good keyboard.</p>
Monitor type does not match CMOS - Run SETUP	<p>The monitor type may be defined incorrectly in SETUP.</p>	<p>Verify that the monitor type is defined correctly in the CMOS setup.</p>
Operating system not found	<p>The operating system cannot be found.</p> <p>The replaceable hard disk drive is not present.</p> <p>The replaceable hard disk drive is jumpered as a slave drive, and a fixed (master) hard disk drive is not present.</p>	<p>Insert a bootable disk into the floppy disk drive and try to reboot.</p> <p>Reload the Windows operating system.</p>
Parity Check 1	<p>A parity error was found on the communications bus. The BIOS will return the address of the error or display ???? if it cannot.</p>	<p>Replace the controller board.</p>
Parity Check 2	<p>A parity error was found on the I/O bus. The BIOS will return the address of the error, or display ???? if it cannot.</p>	<p>Replace the controller board.</p>
Press <F1> to resume, <F2> to Setup	<p>This message is displayed after a recoverable error message. Press the F1 key to restart the boot process, or press the F2 key to enter the CMOS setup and make changes to the definitions.</p>	<p>This is an informational message. Press the F1 key to restart the boot process, or press the F2 key to enter the CMOS setup and make changes to the definitions. Verify that the CMOS setup is configured correctly.</p>
Press and hold CTRL-ALT-F2 to enter SETUP	<p>This is an optional message that can be turned on and off in CMOS setup. It is only displayed during a power-on self-test.</p>	<p>This is an informational message.</p>
Previous boot incomplete - Default configuration used	<p>The previous power-on self- test was not successful. If the power-on self-test fails, it loads default values and displays a message to run the CMOS setup. If incorrect values are loaded, future boot attempts may fail.</p>	<p>This is an informational message. Verify that the CMOS setup is configured correctly.</p>
Real time clock error	<p>The real time clock may be defective.</p>	<p>Replace the controller board.</p>
Shadow Ram Failed at offset: nnnn	<p>The shadow RAM has failed at HEX location nnnn.</p>	<p>The system will run without shadow RAM, but it will run slowly. Exchange the SO DIMMs; if one of the SO DIMMs is defective, the error address should change.</p>
System battery is dead - Replace and run SETUP	<p>The CMOS clock may be dead or disconnected. The CMOS setup may have to be reset.</p>	<p>The system battery is internal to the RAM/Calendar component. To replace the system battery, replace the RAM/Calendar component.</p> <p><b>Note:</b>  <i>After replacing the RAM/Calendar component, you must reflash the BIOS. Refer to Update the BIOS on page 4–67 and perform the procedures to reflash the BIOS.</i></p>



**Table 4-6: BIOS error codes and explanations (Cont.)**

Error code	Explanation	Action to be taken
System BIOS shadowed	The system BIOS was copied to shadow RAM.	This is an informational message. No action needs to be performed.
System cache error - Cache disabled	When the system BIOS failed the cache test, the cache was disabled.	The system will run without cache RAM, but it will run slowly. Try rebooting the system.
System CMOS checksum bad - run SETUP	The system CMOS settings may be incorrect or modified incorrectly by some application. The CMOS setup may have to be re-defined.	This is an informational message. Reboot the system, and then verify that the CMOS setup is configured correctly.
System RAM Failed at offset: nnnn	The system RAM at HEX address nnnn may be defective.	Exchange the SO DIMMs; if one of the SO DIMMs is defective the error address should change.
System timer error	The BIOS failed the timer test. The controller board may be defective.	Try rebooting the system first. If this message keeps reappearing, replace the controller board.

## Update the BIOS Version

On rare occasions it may be necessary to update the controller BIOS version. In most cases this is only necessary to activate enhancements to the product.

To update the BIOS, you will need the latest version of BIOS available on floppy disk. Refer to your *TLA 714 and TLA 720 Installation Manual*.

### Verify the BIOS Version

The BIOS version is briefly displayed on boot up of the portable mainframe. To verify the BIOS version number, power on the portable mainframe and watch the upper left hand section of the screen. A message will be displayed as below:

Copyright 1996 By RadiSys Corporation. Version 2.xx.xx.  
RadiSys boot block version 2.xx.xx

Before continuing, verify that the BIOS version that is displayed is an older version than the version you are installing. The version number is listed on the software floppy diskette.

### Verify Operation

Run the QA+Win32 diagnostic software to verify that all of the functions of the controller are functioning correctly.

After running the QA/Plus/WIN diagnostics, quit the application by selecting **Restart MS Windows**, and clicking the **OK** button. This guarantees that the TLA 700 returns to a stable state for normal operation.

## Adjustment After Repair

There are no adjustment procedures required after replacement of any part of the portable mainframe. Power on the portable mainframe to ensure that it, and any installed modules, pass their power-on diagnostics.

## TLA 700 Startup Sequence

The following information is intended to provide troubleshooting hints in case the logic analyzer fails to complete the startup sequence. You may want to refer to Figure 4–30 on page 4–69 while reading the following paragraphs.

At power on, the mainframe software starts the mainframe and module kernel tests. If the mainframe passes the kernel tests, it attempts to boot the Windows operating system. If the mainframe fails the kernel tests, it displays the error code(s), beeps, and terminates the startup sequence.

The Windows operating system starts the resource manager. The resource manager performs the following tasks:

- Mainframe power-on self tests.
- Verifies the power-on self test status.
- Inhibits any failed modules.
- Records the power-on self test failures.
- Determines the logic analyzer configuration.
- Executes the system controller power-on diagnostics.

After completing all of the above tasks, the logic analyzer starts the TLA 700 application which performs the following tasks:

- Power-on diagnostics on all installed modules.
- Power-on diagnostics on the TLA 700 system.
- Records the Pass/Fail status in the Calibration and Diagnostics property sheet.

If no failures occur, the TLA 700 application is ready to use for regular tasks.

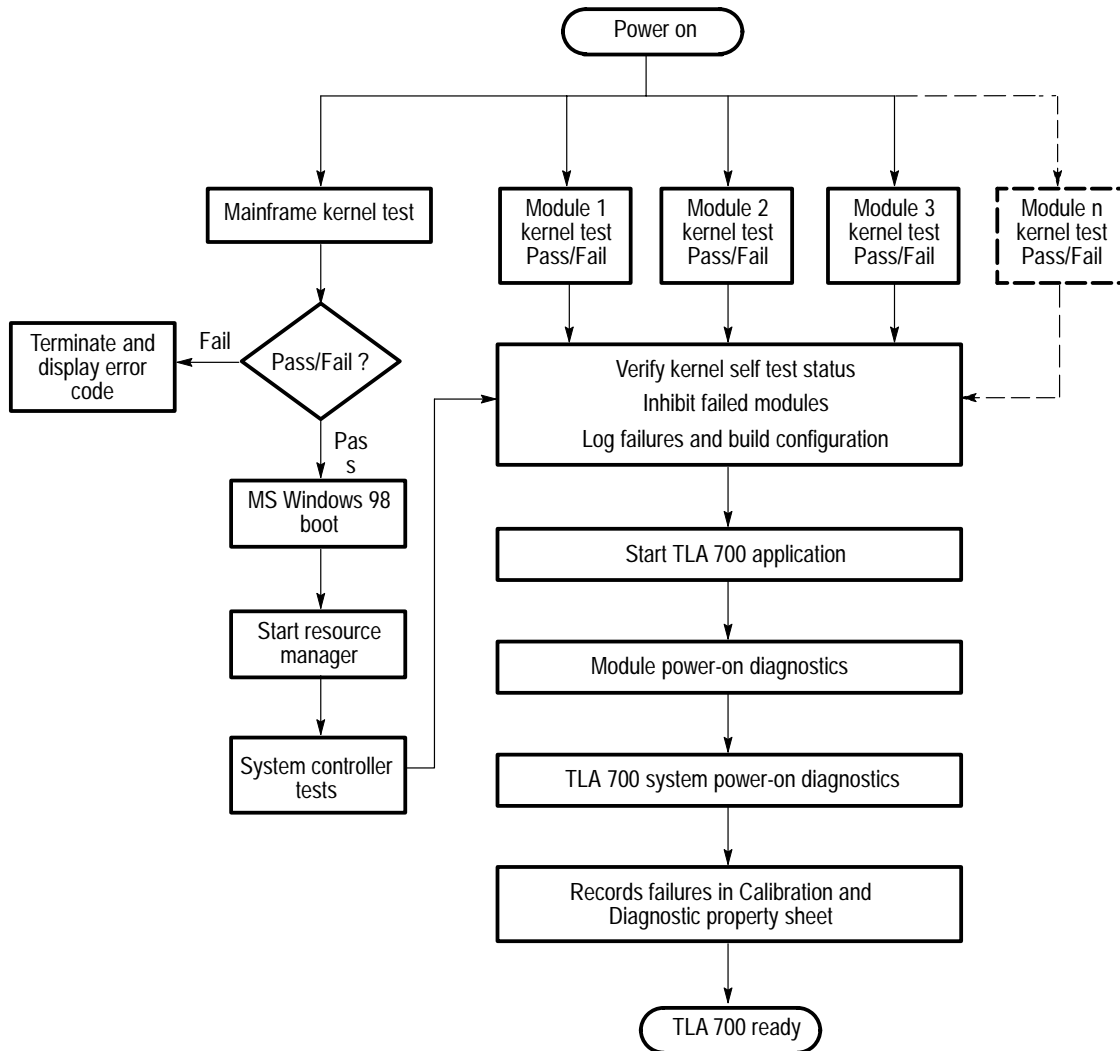

Figure 4-30: TLA 700 startup sequence



# Repackaging Instructions

This section contains the information needed to repack the portable mainframe for shipment or storage.

## Packaging

When repacking the portable mainframe for shipment, use the original packaging. If the packaging is unavailable or unfit for use, contact your local Tektronix representative to obtain new packaging.

Seal the shipping carton with an industrial stapler or strapping tape.

## Shipping to the Service Center

Contact the Service Center to get an RMA (return material authorization) number, and any return or shipping information you may need.

If the instrument is being shipped to a Tektronix Service Center, enclose the following information:

- The RMA number.
- The owner's address.
- Name and phone number of a contact person.
- Type and serial number of the instrument.
- Reason for returning.
- A complete description of the service required.

Mark the address of the Tektronix Service Center and the return address on the shipping carton in two prominent locations.





# Options





# Options

This section provides a list of options that might be installed in the portable mainframe.

For the most up to date information on options and upgrades, contact your Tektronix sales representative.

## Tektronix Options

Table 5–1 lists some of the options for the portable mainframe. These items are separately purchased and installed. Contact your local Tektronix representative for more information.

**Table 5–1: Portable Mainframe options and upgrade kits**

Description	Option	Part number
10BaseT and 10Base2 LAN PC Card	1A	See part list
17-inch Color Monitor	1M	119-5700-XX
21-inch Color Monitor	2M	119-5798-XX
Logic Analyzer Cart	1K	LACART
Power Cord, Universal Euro (230VAC) right-angle straight	A1	161-0104-06 161-0066-09
Power Cord, UK (230VAC) right-angle straight	A2	161-0104-07 161-0066-10
Power Cord, Australian (230VAC) right-angle straight	A3	161-0104-05 161-0066-11
Power Cord, North American (230VAC) right-angle straight	A4	161-0104-08 161-0066-12
Power Cord, Switzerland (230VAC) right-angle straight	A5	161-0167-00 161-0154-00
Service options		See <i>Tektronix Service Options</i>

## Service Options

Tektronix offers the following service options. These options are modular, flexible, and easy to order with your instrument. Designed to ease installation and start up, to support tracking of calibration to requirements of ISO9000, and to provide for extended repair coverage, these options help fix your long-term maintenance costs and eliminate unplanned expenditures. And these options can be converted from service at Tektronix service depots to service on-site (see Option S1 and S3), which helps keep downtime to a minimum.

Product installation service <sup>1</sup>	Option IN	Provides initial product installation/configuration and start-up training session including front panel and product familiarization.
Upgrade installation service <sup>1</sup>	Option IF	Provides installation of product upgrades performed at a Tektronix Service Center.
Three years of calibration services	Option C3	Provides factory calibration certification on delivery, plus two more years of calibration coverage. Throughout the coverage period the instrument will be calibrated according to its Recommended Calibration Interval.
Test data	Option D1	Provides initial Test Data Report from factory on delivery.
Test data	Option D3	Provides test data on delivery plus a Test Data Report for every calibration performed during 3 years of coverage – requires Option C3.
Three years repair coverage	Option R3	Extends product repair warranty to a total of three years.
One year upgrade to on-site service <sup>1,2</sup>	Option S1	Upgrades the standard one year, “return to depot” warranty to an on-site warranty.
Three year upgrade to on-site service <sup>1,2</sup>	Option S3	Upgrades any C3, D3, and R3 options purchased to on-site coverage for three years

<sup>1</sup> Availability of installation and on-site services depends on the type of product and may vary by geography.

<sup>2</sup> Upgrade options are ordered with the mainframe products and cover individual modules.

Tektronix Service Options are available at the time you order your instrument. Contact your local Tektronix Sales Office for more information.

## Power Cord Identification

Table 5-2: Power cord identification

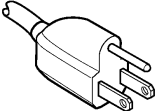
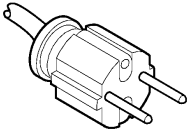
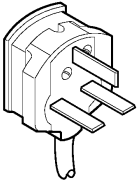
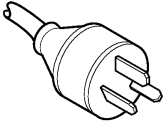
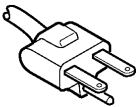
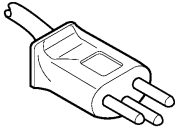
Plug configuration	Normal usage	Option number
	North America 125 V/15A Plug NEMA 5-15P	Standard
	Europe 230 V	A1
	United Kingdom 230 V	A2
	Australia 230 V	A3
	North America 230 V	A4
	Switzerland 230 V	A5





# Diagrams



# Diagrams

## Interconnection Block Diagram

This chapter contains the interconnection diagram and the block diagram for the portable mainframe.

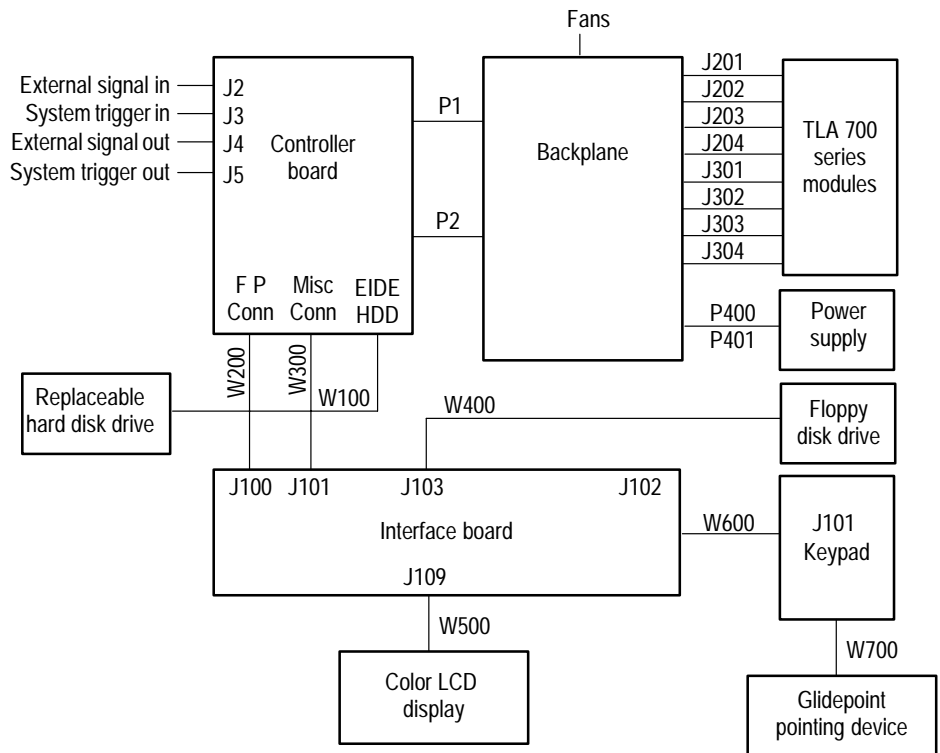

Figure 6-1: Portable mainframe interconnection diagram

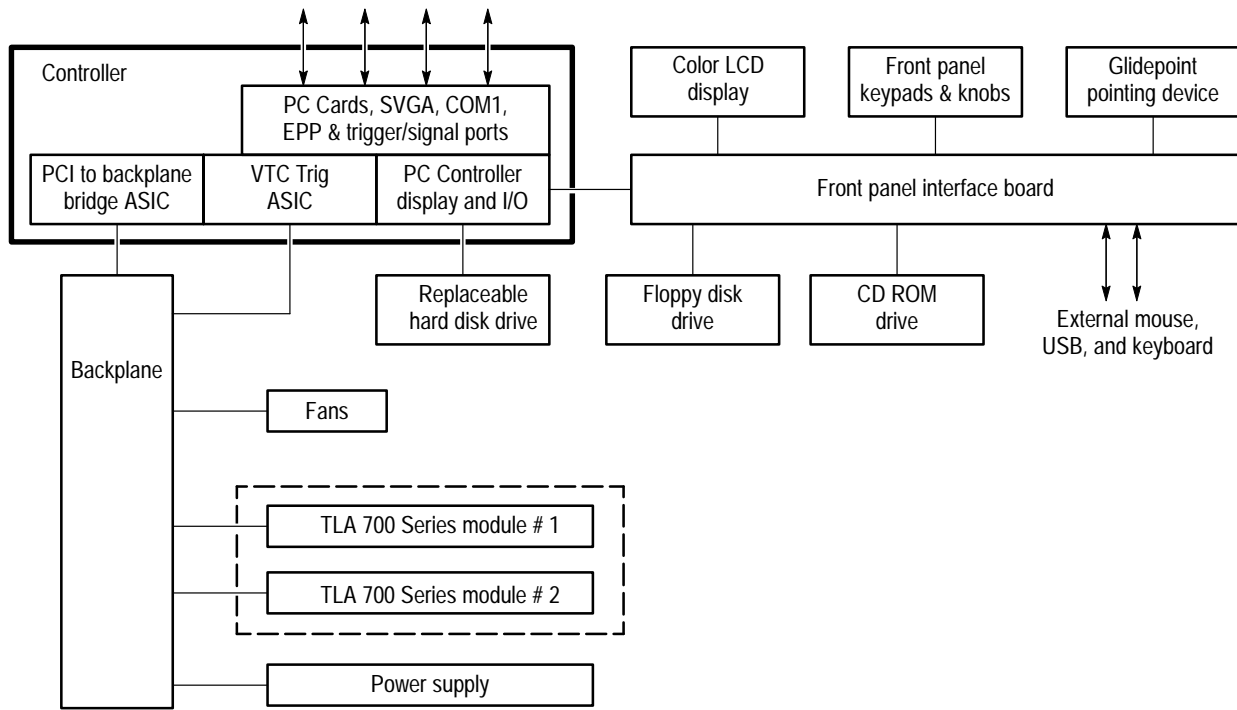

Figure 6-2: Portable mainframe block diagram





# **Replaceable Mechanical Parts**



# Replaceable Mechanical Parts

This chapter contains a list of standard accessories, optional accessories, and replaceable parts.

## Standard Accessories

Table 7-1 lists the standard accessories shipped with the portable mainframe.

**Table 7-1: Standard accessories**

Accessory	Part number
Windows keyboard, PS2 mini-DIN	119-5662-00
Mouse, 3-button, PS2 mini-DIN	119-5662-02
Accessory pouch	016-1441-00
Front panel cover	200-4279-00
Dual wide slot fillers	333-4206-00
Printer adapter cable	015-0687-00
Windows 98 package (software and manual)	063-3135-00
TLA 700 application software TLA TPI client software Diagnostics software	063-3022-XX
Windows 98 preinstall internal/external CDROM boot disk	063-3227-XX
Flash jumper with pull tab (for flashing module firmware)	131-4356-00
Power cord clip	343-1213-00
TLA 700 Series, Version 3.1, User Manual	071-0684-XX
Tek mouse pad	016-1524-XX
Cap, fuse holder	200-4326-00
Fuse, 15A	159-0256-00
Fuse, 6.3A	159-0381-00
Fuse, 20A	159-0379-00

## Optional Accessories

Table 7–2 lists the optional accessories available for the portable mainframe.

**Table 7–2: Standard accessories**

Accessory	Part number
Power cord, North American right angle straight	161–0104–00 161–0066–00
Power cord, Universal Euro right angle straight	161–0104–06 161–0066–09
Power cord, UK right angle straight	161–0104–07 161–0066–10
Power cord, Australian right angle straight	161–0104–05 161–0066–11
Power cord, Switzerland right angle straight	161–0167–00 161–0154–00
Transport hard case, wheeled	016–1522–00
TLA 7Nx and TLA 7Px Logic Analyzer Module Service Manual	071–0266–XX
TLA 7D1/7D2/7E1/7E2 Oscilloscope Module Service Manual	070–9780–XX
Performance Verification and Adjustment Technical Reference	070–9776–XX

## Parts Ordering Information

Replacement parts are available through your local Tektronix field office or representative.

Changes to Tektronix products are sometimes made to accommodate improved components as they become available and to give you the benefit of the latest improvements. Therefore, when ordering parts, it is important to include the following information in your order.

- Part number (see Part Number Revision Level below)
- Instrument type or model number
- Instrument serial number

- Instrument modification number, if applicable

If you order a part that has been replaced with a different or improved part, your local Tektronix field office or representative will contact you concerning any change in part number.

Change information, if any, is located at the rear of this manual.

**Part Number Revision Level**

Tektronix part numbers contain two digits representing the revision level of the part. For most parts in this manual, you will find the letters XX in place of the revision level number.

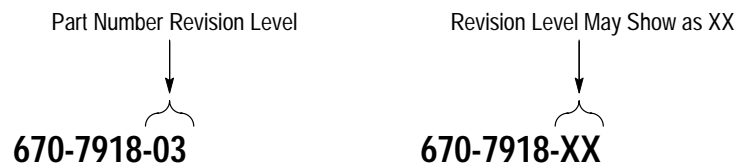

When you order parts, Tektronix will provide you with the most current part for your product type, serial number, and modification (if applicable). At the time of your order, Tektronix will determine the part number revision level needed for your product, based on the information you provide.

**Module Servicing**

Modules can be serviced by selecting one of the following options. Contact your local Tektronix service center or representative for repair assistance.

**Module Repair and Return.** You may ship your module to Tektronix for repair, after which Tektronix will return it to you.

**New Modules.** You may purchase replacement modules in the same way as other replacement parts.

**Using the Replaceable Parts List**

The rest of this chapter contain lists of the replaceable mechanical and/or electrical components of the Portable Mainframe. Use these lists to identify and order replacement parts. The following table describes each column in the lists.

**Table 7-3: Parts lists column descriptions**

Column number	Column name	Description
1	Figure & Index Number	Figure and index numbers in the exploded view illustrations.
2	Tektronix Part Number	Use this part number when ordering replacement parts from Tektronix.
3 and 4	Serial Number	Column 3 indicates the serial number at which the part was first effective. Column 4 indicates the serial number at which the part was discontinued. No entries in either column indicates the part is good for all serial numbers.
5	Qty	Quantity of parts used.
6	Name & Description	An item name is separated from the description by a colon (:). Because of space limitations, an item name may sometimes appear incomplete. Use the U. S. Federal Catalog Handbook H6-1 for further item name identification.
7	Mfr. Code	Manufacturer code.
8	Mfr. Part Number	Manufacturer's or vendor's part number.

**Abbreviations**

Abbreviations conform to American National Standard ANSI Y1.1-1972.

**Mfr. Code to Manufacturer Cross Index**

The table titled Manufacturers Cross Index shows codes, names, and addresses of manufacturers or vendors of components listed in the parts list.

**Manufacturers Cross Index**

Mfr. Code	Manufacturer	Address	City, State, Zip Code
0VF15	TOTAL TECHNOLOGIES LTD	9 STUDEBAKER	IRVINE, CA 92618
0ZQ35	3COM CORPORATION	5353 BETSY ROSS DRIVE	SANTA CLARA, CA 95052-8145
1DM20	PARLEX CORP	7 INDUSTRIAL WAY	SALEM, NH 03079
22526	BERG ELECTRONICS INC	825 OLD TRAIL ROAD	ETTERS, PA 17319-9769
31918	ITT SWITCH PRODUCTS	8081 WALLACE RD	EDEN PRAIRIE, MN 55344-8798
34416	PARSONS MANUFACTURING CORP	1055 O'BRIEN DRIVE	MENLO PARK, CA 940251476
46628	LOGITECH INC	6505 KAISER DR	FREMONT, CA 94555
50356	TEAC AMERICA INC	7733 TELEGRAPH RD PO BOX 750	MONTEBELLO, CA 90640-6537
7X318	KASO PLASTICS INC	5720-C NE 121ST AVE, STE 110	VANCOUVER, WA 98682
S5341	ALPS ELECTRIC CO LTD	1-7 YUKIGAYA-OHTSUKA-CHO OHTA-KU TOKYO JAPAN	

## Manufacturers Cross Index (Cont.)

Mfr. Code	Manufacturer	Address	City, State, Zip Code
S5769	NEC CORPORATION	NEC BUILDING 7-1, SHIBA 5 CHOME MINATO-KU	TOKYO, JP 108
TK1943	NEILSEN MANUFACTURING INC	3501 PORTLAND RD NE	SALEM, OR 97303
TK2157	CONNECTOR TECHNOLOGY INC	5065 E HUNTER AVE	ANAHEIM, CA 92807-6001
TK2383	PANASONIC INDUSTRIAL CO	1600 MCCANDLESS DR	MILPITAS, CA 95035
TK2647	INSTRUMENT SPECIALTIES CO INC.	C/O TEMCO NW 1336 SE 51ST STREET	HILLSBORO, OR 97123
TK6110	OWNCO MARKETING	14150 SW MILTON CT	TIGARD, OR 97224
06383	PANDUIT CORP	17303 RIDGELAND AVE	TINLEY PARK, IL 60477-3048
0B445	ELECTRI-CORD MFG CO INC	312 EAST MAIN STREET	WESTFIELD, PA 16950
0L0L7	RADISYS CORPORATION	5445 NE DAWSON CREEK DRIVE	HILLSBORO, OR 97124
0VF15	TOTAL TECHNOLOGIES LTD	2110 S ANNE ST	SANTA ANNA, CA 92704
12136	PHC INDUSTRIES INC	1643 HADDON AVE; PO BOX 1448	CAMDEN, NJ 08103
1GM54	ZYTEC CORP	7575 MARKET PLACE DR	EDEN PRAIRIE, MN 55344
0KB01	STAUFFER SUPPLY CO	810 SE SHERMAN	PORTLAND, OR 97214-4657
0KB05	NORTH STAR NAMEPLATE INC	5750 NE MOORE COURT	HILLSBORO, OR 97124-6474
0RAG4	MERITEC	1359 W JACKSON ST PO BOX 8003	PAINESVILLE, OH 44077
26742	METHODE ELECTRONICS INC	BACKPLAIN DIVISION 7444 WEST WILSON AVE	CHICAGO, IL 60656-4548
7X318	KASO PLASTICS INC	5720-C NE 121ST AVE, STE 110	VANCOUVER, WA 98682
2W733	BELDEN WIRE & CABLE COMPANY	2200 US HWY 27 SOUTH; PO BOX 1980	RICHMOND, IN 47374
4T165	NEC ELECTRONICS, INC.	2880 SCOTT BLVD; PO BOX 58062	SANTA CLARA, CA 95052-8062
50356	TEAC AMERICA INC	7733 TELEGRAPH RD; PO BOX 750	MONTEBELLO, CA 90640-6537
00779	AMP INC.	CUSTOMER SERVICE DEPT PO BOX 3608	HARRISBURG, PA 17105-3608
09353	C & K COMPONENTS CORP	57 STANLEY AVE	WATERTOWN, MA 02172-4802
0D1M6	NMB TECHNOLOGIES INC	9730 INDEPENDENCE AVE	CHATSWORTH, CA 91311
5F520	PANEL COMPONENTS CORP	PO BOX 115	OSKALOOSA, IA 52577-0115
60128	MICROSOFT CORPORATION	ONE MICROSOFT WAY; DEPARTMENT 101	REDMOND, WA 98052-8300
61935	SCHURTER INC	1016 CLEGG CT PO BOX 750158	PETALUMA, CA 94975-0158
6V439	ERNI COMPONENTS INC	12701 NORTH KINGSTON AVENUE	CHESTER, VA 23831
049S6	FUJITSU COMPUTER PRODUCTS OF AMERICA INC	2904 ORCHARD PARKWAY	SAN JOSE, CA 95134-2009
6Y440	MICRON SEMICONDUCTOR PRODUCTS INC	8000 S FEDERAL WAY; PO BOX 6	BOISE, ID 83707-0006
71400	BUSSMANN DIV OF COOPER INDUSTRIES INC	114 OLD STATE RD PO BOX 1460	ST LOUIS MO 63178
80126	PACIFIC ELECTRICORD CO	747 WEST REDONDO BEACH; PO BOX 10	GARDENA, CA 90247-4203
S3109	FELLER U.S. CORPORATION	72 VERONICA AVE; UNIT #4	SOMERSET, NJ 08873
TK1163	POLYCAST INC	9898 SW TIGARD ST	TIGARD, OR 97223

**Manufacturers Cross Index (Cont.)**

<b>Mfr. Code</b>	<b>Manufacturer</b>	<b>Address</b>	<b>City, State, Zip Code</b>
TK1373	PATELEC-CEM	10156 TORINO	VAICENTALLO, ITALY 62/456
TK2157	CONNECTOR TECHNOLOGY INC	5065 E HUNTER AVE	ANAHEIM, CA 92807-6001
TK2383	PANASONIC INDUSTRIAL CO	1600 MCCANDLESS DR	MILPITAS, CA 95035
TK2469	UNITREK CORPORATION	3000 LEWIS & CLARK HWY; SUITE 2	VANCOUVER, WA 98661
TK2541	AMERICOR ELECTRONICS LTD	UNIT-H; 2682 W COYLE AVE	ELK GROVE VILLAGE, IL 60007
TK2647	INSTRUMENT SPECIALTIES CO INC.	C/O TEMCO NW; 1336 SE 51ST STREET	HILLSBORO, OR 97123
0B445	ELECTRI-CORD MFG CO INC	312 EAST MAIN STREET	WESTFIELD, PA 16950
80126	PACIFIC ELECTRICORD CO	747 WEST REDONDO BEACH PO BOX 10	GARDENA, CA 90247-4203
80009	TEKTRONIX INC	14150 SW KARL BRAUN DR PO BOX 500	BEAVERTON, OR 97077-0001





**Replaceable Parts List**

Fig. & Index Number	Tektronix Part Number	Serial No. Effective	Serial No. Discont'd	Qty	Name & Description	Mfr. Code	Mfr. Part Number
1-1	016-1441-00			1	POUCH, PLASTIC: PLASTIC POUCH	80009	016-1441-00
-2	200-4275-00			1	COVER, TOP: PLASTIC TOP COVER	80009	200-4275-00
-3	211-0721-00			10	SCREW, MACHINE: 6-32 X 0.375, PNH, STL, CDPL, T-15 TORX DR	0KB01	ORDER BY DESCRIPTION
-4	348-1479-00			2	FOOT, REAR: PLASTIC REAR FOOT	80009	348-1479-00
-5	348-1254-01			8	PAD, FOOT: TEK BLACK, SANTOPRENE	80009	348-1254-01
-6	343-1213-00			1	CLAMP, PWR CORD: POLYIMIDE	TK1163	ORDER BY DESCRIPTION
-7	200-4430-00			1	COVER: RIGHT, PLASTIC	7X318	2TEK1581X
-8	200-4280-00			1	COVER: BOTTOM COVER, 0.050 SHEET METAL	80009	200-4280-00
-9	348-1515-00			0	FOOT, CABINET: BLACK PLASTIC, 63-526, SET OF 4	80009	348-1515-00
-10	200-4279-00			1	COVER, FRONT: FRONT, PROTECTIVE, ABS, TEK BLUE	80009	200-4279-00
-11	214-4718-00			1	ACTUATOR, SWITCH: ACTUATOR, ON/STANDBY	80009	214-4718-00
-12	101-0149-00			1	TRIM, RING: FRONT TRIM RING, PLASTIC	80009	101-0149-00
-13	334-9634-00			1	MARKER, IDENT: LABEL, GE LEXAN, W/ADHESIVE	0KB05	334-9634-00
-14	200-4469-00			1	COVER: LEFT, PLASTIC	7X318	200-4469-00

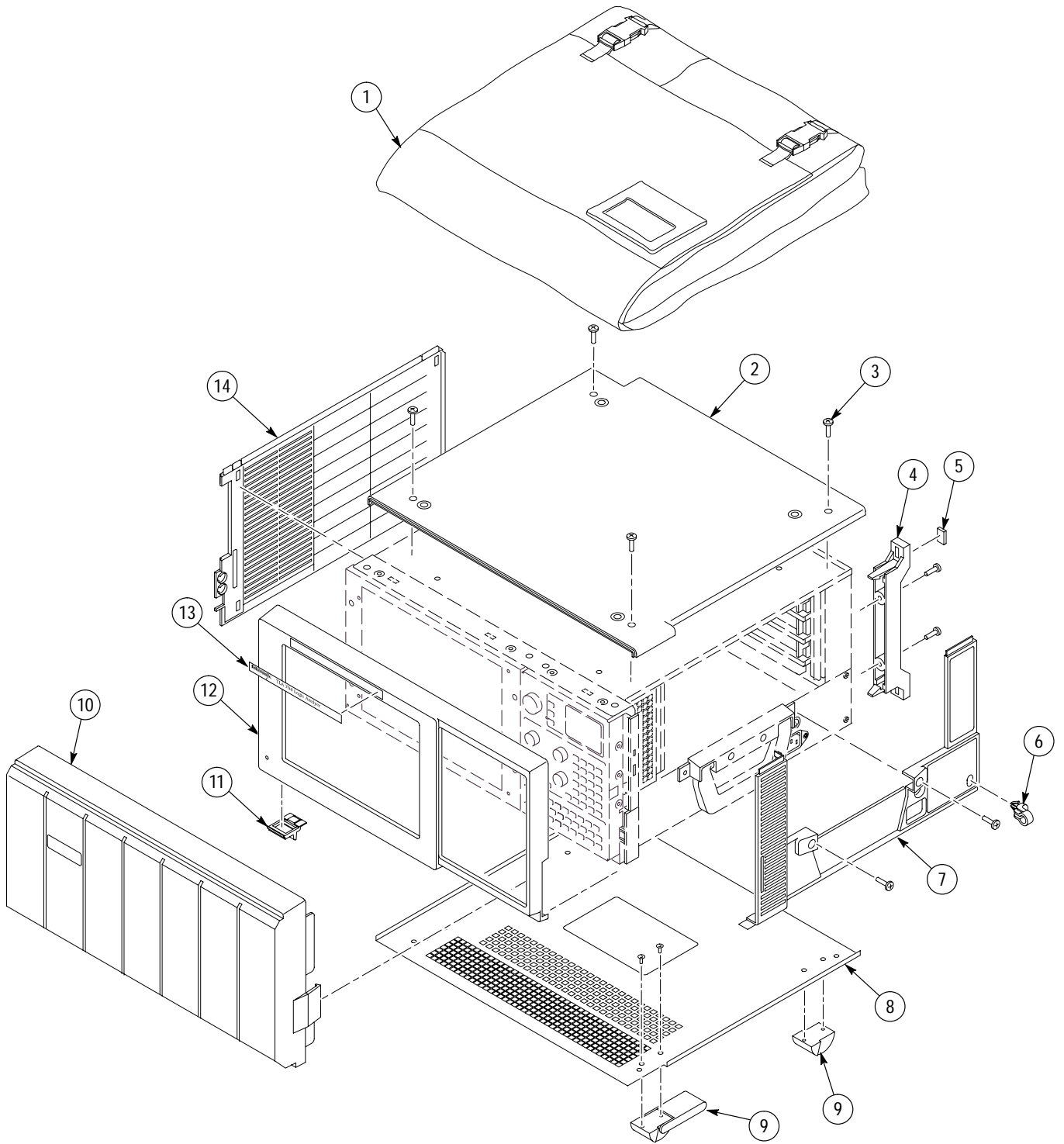

Figure 7-1: External parts

Replaceable Parts List

Fig. & Index Number	Tektronix Part Number	Serial No. Effective	Serial No. Discont'd	Qty	Name & Description	Mfr. Code	Mfr. Part Number
2-1	650-3801-00			1	FRAME ASSY: DISPLAY	80009	650-3801-00
-2	337-4173-01			1	SHIELD: DISPLAY, 0.025 AL, CLR CHROMATE	TK1943	337-4173-01
-3	174-4187-00			1	CABLE ASSY,SP:RIBBON,DISPLAY,IDC,40 2 X 10,6.7 L,RCPT BOTH ENDS,SPECIAL FOLD	ORAG4	174-4187-00
-4	211-0721-00			9	SCREW,MACHINE: 6-32 X 0.375,PNH, T-15 TORX DR	OKB01	ORDER BY DESCRIPTION
-5	671-4379-00			1	CIRCUIT BD ASSY: CONNECTOR CONVERSION	80009	671-4379-00
-6	211-1081-00			4	SCREW,MACHINE:M3 X 0.5 X 3.5MM,FLAT WAFER HD W/SERRATIONS STRESS RELIEVED,PHL,0.0002 STL ZI PL	OKB01	211-1081-00
-8	671-4378-00			1	CIRCUIT BD ASSY: HARD DISK DRIVE	80009	671-4378-00
-9	174-3925-00			1	CA ASSY,SP:RIBBON,CD ROM AUDIO CABLE ,IDC,44,28 AWG,1MM,1.0 L,2 X 22,0.079 CTR (2MM),RCPT,W/	060D9	174-3925-00
-10	119-6061-00			1	DISK DRIVE:WINCHESTER, 2.5 IN, 2.1GB, 9.5 MM, IDE, MHF2021AT	049S6	MHF2021AT
-10	119-6071-00			1	DISK DRIVE:WINCHESTER, 2.5 IN, 6.4GB, 9.5 MM, IDE, MHE2064AT	049S6	MHE2064AT
-11	437-0479-00			1	CABINET ASSY: REMOVEABLE HARD DISK DRIVE HOLDER (DOES NOT INCLUDE HARD DISK DRIVE)	TK1943	437-0479-00
-12	650-4018-00			1	RHDD ASSEMBLY: MIN REPLACEABLE HARD DISK DRIVE, W/O SW INSTALLED	80009	650-4018-00
-12	650-4019-00			1	RHDD ASSEMBLY: MAX REPLACEABLE HARD DISK DRIVE, W/OSW INSTALLED	80009	650-4019-00
-13	671-4377-00			1	CIRCUIT BD ASSY: CD ROM INTERFACE	80009	671-4377-00
-14	119-5728-00			1	DISK DRIVE:OPTICAL, 644MB, CD-ROM, 16.7 MB/SEC, IDE/ATAPI, CD-224	50356	CD-224E-903
-16	211-1071-00			3	SCREW:M2 X 2MM,FLT, PHL, STL NI PLT	OKB01	211-1071-00
-17	407-4570-00			1	BRACKET: CD ROM	TK1943	407-4570-00
-18	614-0978-00			1	PANEL ASSEMBLY:FRONT,W/O CD ROM ASSEMBLY	80009	614-0978-00
-19	671-3487-01			1	CIRCUIT BD ASSY:FRONT PANEL,389-2042-00,TESTED	80009	671-3487-01
-21	214-4703-00			1	ACTUATOR:ELASTOMERIC, SWITCHMAT	80009	214-4703-00
-22	650-3811-00			1	FRAME ASSY: FRONT PANEL	80009	650-3811-00
-24	366-0771-00			4	KNOB,CAP:0.650 DIA,MACROBLEND DP4-1368	TK1163	366-0771-00
-25	366-0770-00			1	KNOB,CAP:0.925 DIA,MACROBLEND DP4-1368	TK1163	366077000
-26	352-1063-00			1	OPTO, PASSIVE:LIGHT PIPE, 0.14 DIA X 1.445 INCHES LONG, CLEAR ACRYLIC	80009	352-1063-00
-	174-3520-00			1	CABLE ASSY,SP:FLAT FLEX,FLX,8,0.039 CTR,60.0 L,LAMINATED POLYESTER,3MM,EXPOSED CONDUCTOR BOTH	1DM20	174-3520-00

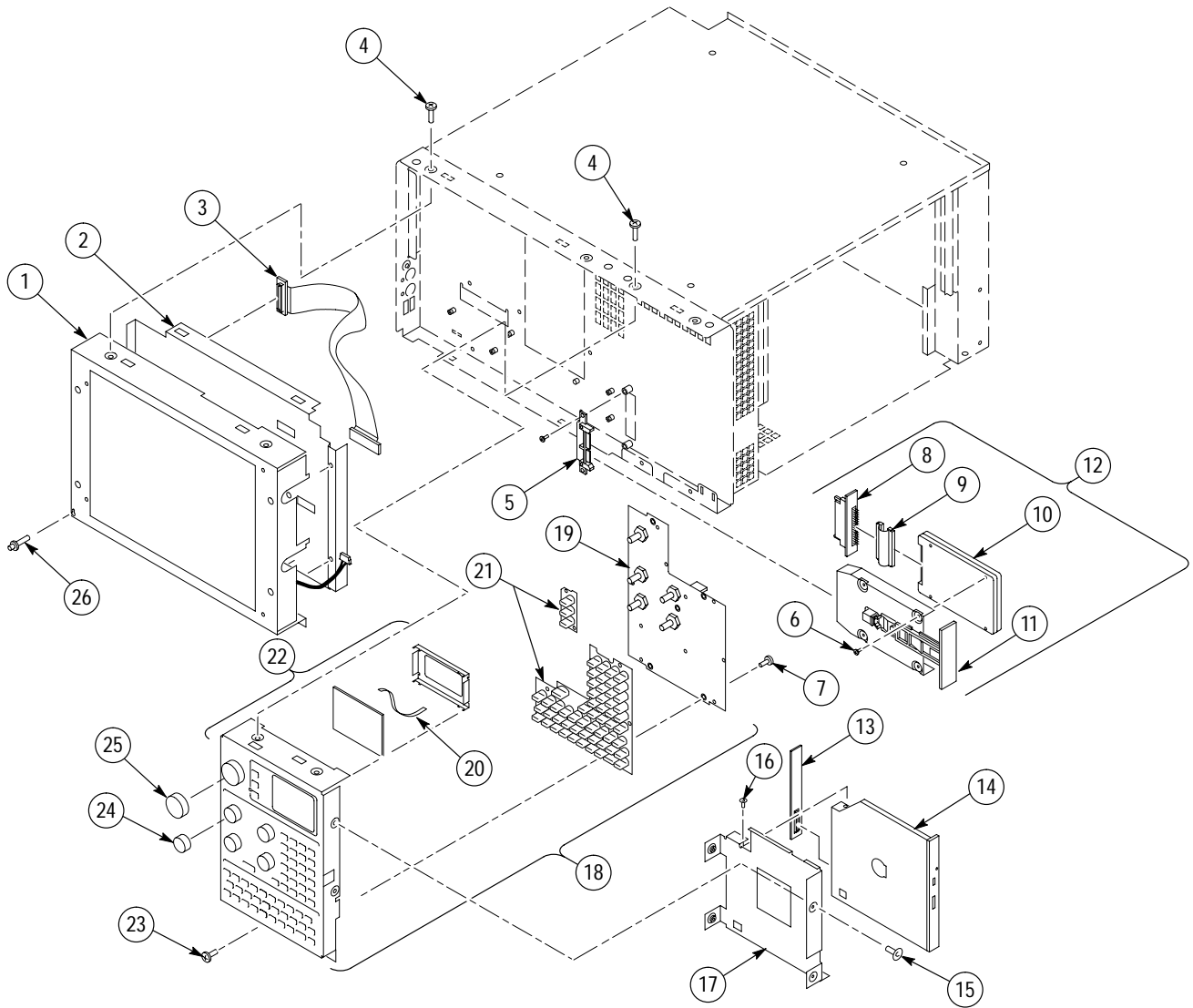

Figure 7-2: Front panel assembly

Replaceable Parts List

Fig. & Index Number	Tektronix Part Number	Serial No. Effective	Serial No. Discont'd	Qty	Name & Description	Mfr. Code	Mfr. Part Number
3-1	407-4682-00			1	BRACKET: HARD DRIVE	TK1943	407-4682-00
-2	211-0721-00			4	SCREW,MACHINE: 6-32 X 0.375, PNH, T-15 TORX DR	OKB01	ORDER BY DESCRIPTION
-3	174-3923-00			1	CA ASSY,SP:RIBBON,IDC,44, 28 AWG,1MM,2X22,0.079 CTR,2MM,RCPT W/O STRAIN RELIEF BOTH ENDS,1	060D9	174-3923-00
-4	671-4381-00			1	CIRCUIT BD ASSY: INTERFACE	80009	671-4381-00
-5	174-4186-00			1	CA ASSY,SP:RIBBON,FRONT PANEL,IDC,34,28 AWG,6.0 L,2 X 17,0.1 CTR,RCPT,NON PLZ,BOTH ENDS,SPE	060D9	174-4186-00
-6	174-3732-00			1	FLOPPY DRIVE CABLE		
-7	174-3924-00			1	CA ASSY,SP:RIBBON,HD, IDC,44, 28 AWG,1MM,2X22,0.079 CTR,2MM,RCPT W/O STRAIN RELIEF THREE EN	060D9	174-3924-00
-8	211-0721-00			1	SCREW,MACHINE: 6-32 X 0.375, PNH, T-15 TORX DR	OKB01	ORDER BY DESCRIPTION
-9	211-0840-00			1	SCREW,MACHINE: M2.6 X 0.45MM PITCH X 4.0MM L, PHILIPS, PNH	OKB01	.26C4MXPHY
-10	407-4381-00			1	BRACKET: FLOPPY DRIVE BRACKET	80009	407-4381-00
-11	119-5677-02			1	DISK DRIVE: FLOPPY, 3.5 INCH, 1.44MB, BLACK, 0.5 INCH HIGH, DSDD, FD-04HG-2600	50356	FD-04HG-2600
-12	211-0895-00			2	SCREW,MACH:M2.6 X 0.45 X 8MM,PHILLIPS,PNH,ZINC YELLOW	OKB01	211-0895-00

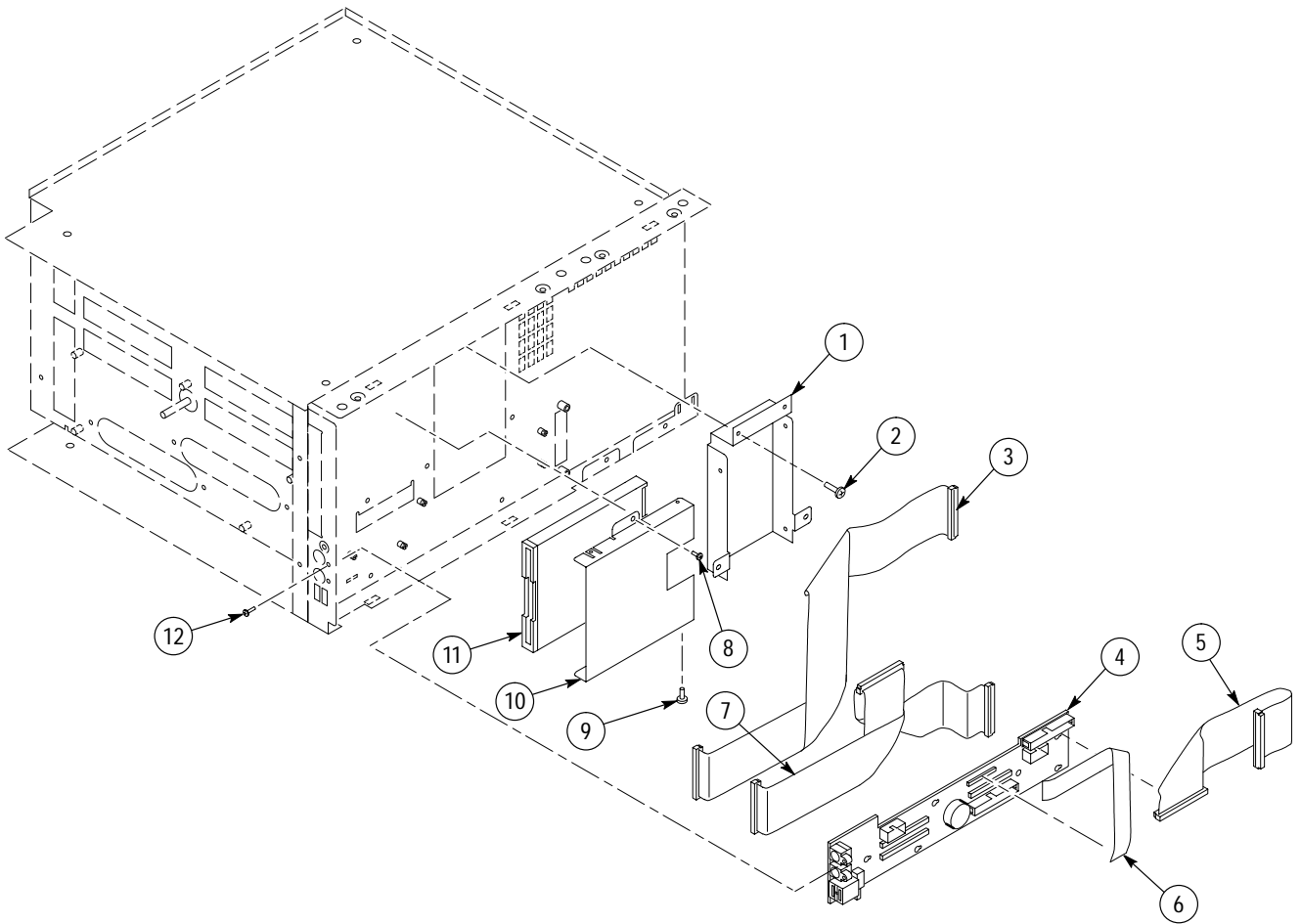

Figure 7-3: Floppy disk drive, front panel interface board, and related cables

**Replaceable Parts List**

Fig. & Index Number	Tektronix Part Number	Serial No. Effective	Serial No. Discont'd	Qty	Name & Description	Mfr. Code	Mfr. Part Number
4-1	118-9160-00			1	BACK PLANE:4 SLOT BACKPLANE ASSY,VXI	TK2157	118-9160-00
-2	211-0721-00			1	SCREW,MACHINE:6-32 X 0.375,PNH,STL,CDPL,T-15 TORX DR	OKB01	ORDER BY DESCRIPTION
-3	039-0047-00			1	CONTROLLER BD: PENTIUM CONTROLLER	0L0L7	OBD
-4	174-4259-00			1	CA ASSY,SP:RIBBON,IDC,28 AWG,1MM,8.0 L,2 X 25,0.079CTR(2MM) BOTH ENDS,SAME SIDE,SPECIAL FO	060D9	174-4259-00
-5	156-8389-00			1	IC,MEMORY:CMOS,SDRAM,8MEG X 64,64M,SYNCHRONOUS,100MHZ,7NS,MODULE,MC-458CD6 4S-A10B,SODIMM14	S5769	MC-458CD64S-A10 B
-6	337-4191-00			1	SHIELD,ELEC:PROCESSOR,0.050 AL	TK1943	337-4191-00
-7	012-0057-01			1	CA ASSY,RF:COAXIAL,RFD,50 OHM,43 L,BNC,MALE,STR,BOTH ENDS,W/STRAIN RELIEF BOOT BOTH ENDS,	060D9	012-0057-01
-8	PART OF ITEM 3			1	REAR PANEL		



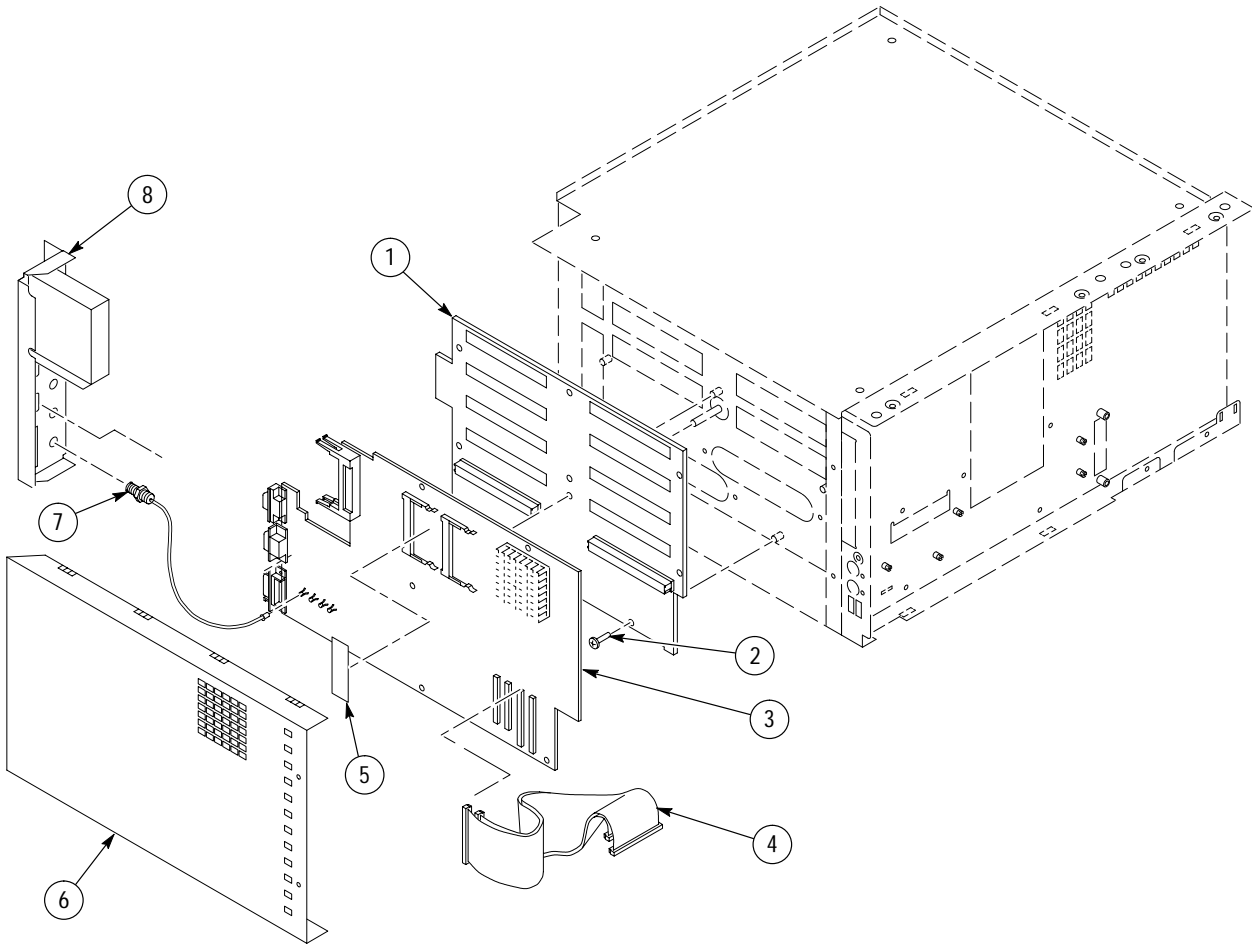

Figure 7-4: Controller board and EMI shield

Replaceable Parts List

Fig. & Index Number	Tektronix Part Number	Serial No. Effective	Serial No. Discont'd	Qty	Name & Description	Mfr. Code	Mfr. Part Number
5-1	441-2154-00			1	CHASSIS,MAIN:AL	TK1943	441-2154-00
-2	436-0296-00			1	TRAY,FAN:CHASSIS ASSY,W/FANS MOUNTED	80009	436-0296-00
-3	119-5522-00			6	FAN,DC: TUBE AXIAL, 24V, 4.3W, 3200RPM, 54.7CFM RIBBED MOUNTING FLANGE	0D1M6	3610KL-05W-B50-L00
-4	386-0076-00			2	PLATE,CMPNT NTG:PLATE, FAN MOUNT	80009	386-0076-00
-5	211-0895-00			2	SCREW,MACH:M2.6 X 0.45 X 8MM,PHILLIPS,PNH,ZINC YELLOW	0KB01	211-0895-00
-6	351-0979-00			2	GUIDE,CARD:GUIDE,DIN 41612,ACCOM C MALE,FRONT PANEL,3 X 32	6V439	043 520
-7	348-1365-01			1	SHLD GSKT,ELEC:SYMMETRICAL SLOTTED FINGER,0.350 W X 7.5 L,RIVIT MTG,SNAP-IN,RIVIT SPACING 1.5 IN	TK2647	0493-0069-01
-8	441-2093-00			1	CHASSIS:CHASSIS,BRACE WITH EMI GASKET	80009	441-2093-00
-9	159-0046-00			1	FUSE,CARTRIDGE:3AG,8A,250V,15SEC,CER	71400	ABC 8
-9	159-0381-00			1	FUSE,CARTRIDGE:5 X 20 MM,6.3A,250V,FAST BLOW,HIGH BREAKING CAPACITY,UL REC,SEMKO,	71400	GDA-6.3
-10	200-2264-00			1	CAP,FUSEHOLDER:3AG FUSES	61935	FEK 031 1666
-10	200-2265-00			1	CAP,FUSEHOLDER:5 X 20MM FUSES	61935	031.1663
-11	367-0477-00			1	HANDLE,CARRYING:DUAL DUROMETER MOLDED HANDLE, POLYPROPYLENE HANDLE VINYL GRIP SECTION	12136	PT 3170
-12	407-4459-00			1	BRACKET:HANDLE BRACKET,PLASTIC,	80009	407-4459-00
-13	211-0721-00			6	SCREW,MACHINE: 6-32 X 0.375, PNH,T-15 TORX DR	0KB01	ORDER BY DESCRIPTION
-14	119-4933-01			1	POWER SUPPLY: POWER SUPPLY ASSY	1GM54	119-4933-01
-	650-3591-01			1	PWR SUPPLY ASSY: HANDLE AND POWER SUPPLY	80009	650-3591-01
-16	020-2205-00			2	NUTBAR/SET SCREWS		
-17	378-0449-00			1	SHUTTER ASSY: INCLUDING FRAME, ACTUATOR, FIN, SPRING	7X318	2TEK1588
-18	131-6417-00			3	CONTACT, ELEC: GROUNDING	TK2647	7701118003

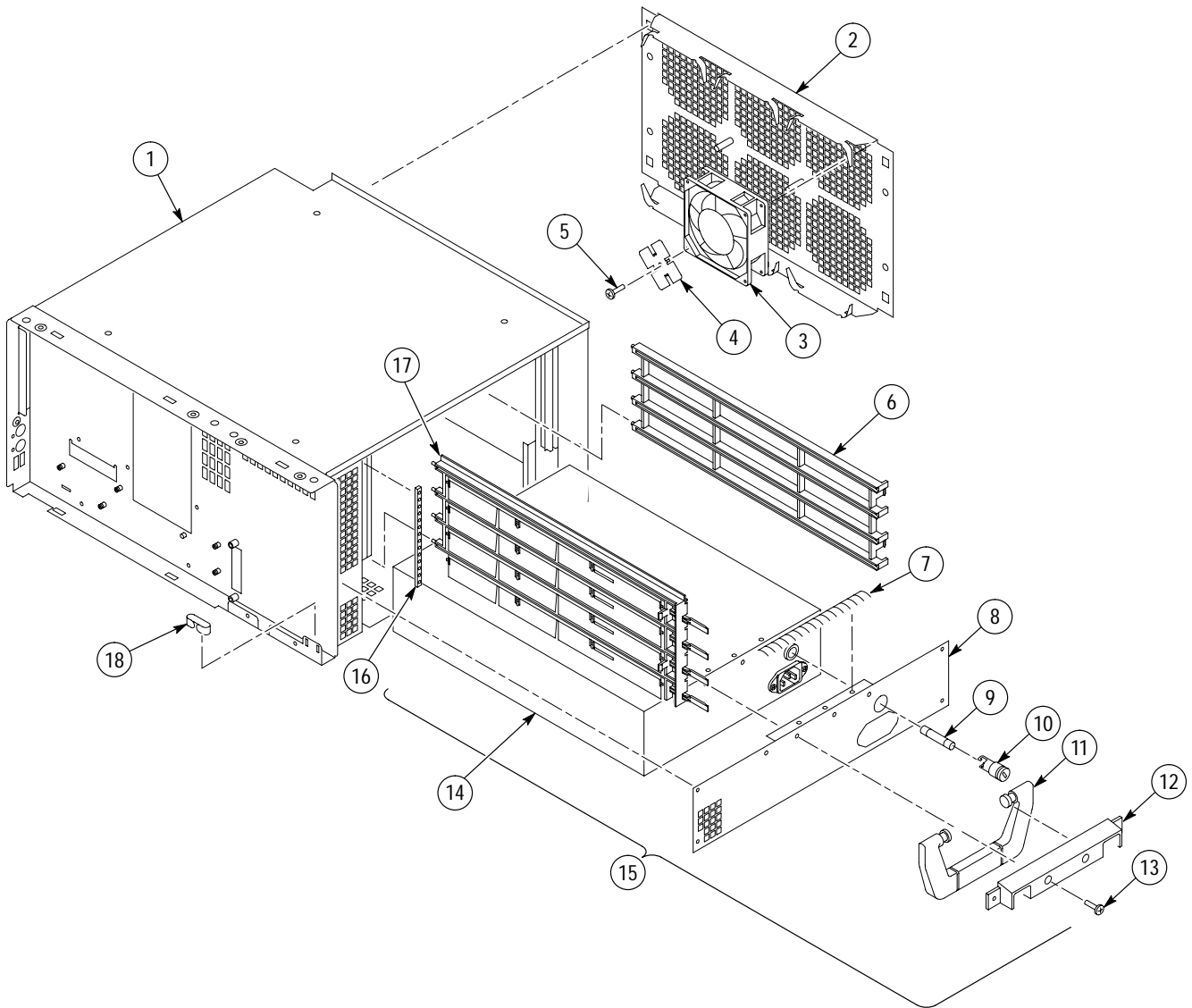

Figure 7-5: Power supply and fan

Replaceable parts List

Fig. & index number	Tektronix part number	Serial no. effective	Serial no. discont'd	Qty	Name & description	Mfr. code	Mfr. part number
<b>STANDARD ACCESSORIES</b>							
	015-0687-00			1	CABLE,INTCON:IEEE1284,SHIELDED COMPOSITE, 25,28 AWG,17 TW PR,1 METER, 25 POSITION,FEMALE DSUB	0VF15	015-0687-00
	016-1524-01			2	MOUSE PAD: TEKTRONIX TLA700 SERIES	TK6110	016-1524-01
	119-4330-02			1	POINTER ASSY: MOUSE,400 DPI MOUSE, LOGITECH, SAD35-6MD	46628	SAD35-6MD
	071-0265-XX			1	MANUAL,TECH: USER,TLA700 SERIES	TK2548	071-0265-00
	071-0264-XX			1	MANUAL,TECH:INSTALLATION,TLA700 SERIES	TK2548	071-0264-00
	119-5662-00			1	KEYBOARD:104 WINDOWS,RT5156TW	0D1M6	122761-001
	131-4356-00			5	CONN,SHUNT:SHUNT/SHORTING,FEMALE,1 X 2,0.1 CTR,0.63 H,BLK,W/HANDLE,JUMPER,30 GOLD	26742	9618-302-50
	200-4279-00			1	COVER,FRONT:FRONT, PROTECTIVE, ABS, TEK BLUE	7X318	1425
<b>OPTIONAL ACCESSORIES</b>							
	119-6072-00			1	LAN PC CARD:10/100 LAN CARDBUS,32-BIT PC CARD,10BASE-T,3COM MODEL #3CXFE575BT	0ZQ35	3CCFE575BT
	020-2194-00			1	COMPONENT KIT:BACKPLANE,EMI SHIELD W/SCREWS,BACKPLANE,TLA704/TLA711	TK2157	020-2194-00
	071-0266-XX			1	MANUAL,TECH:SERVICE,LOGIC ANALYZER MODULE,TLA7NX/TLA7PX SERIES	TK2548	071-0266-00
	070-9776-XX			1	MANUAL, TECH: TECHNICAL REFERENCE, TLA700 SERIES PERFORMANCE VERIFICATION AND ADJUSTMENT	80009	070-9776-00
	071-0567-XX			1	MANUAL,TECH:INSTRUCTION,P6417/P6418 LOGIC ANALYZER PROBE	TK2548	071-0567-00
	070-9780-XX			1	MANUAL, TECH: SERVICE, TLA7D1, TLA7E1 DIGITIZING OSCILLOSCOPE MODULE	80009	070-9780-XX
	119-5430-00			1	DISPLAY,MONITOR:17 INCH,COLOR,30-86KHZ MULTI SYNC, 0.27MM DOT PITCH,FLAT CRT,PWR SAVING,ON SCREE	80009	119-5430-00
	119-5798-00			1	DISPLAY,MONITOR:21 INCH,COLOR MULTI-SYNC MONITOR,1600 X 1200,30-95 KHZ,0.25MM DOT PITCH,ON SCREE	TK2383	TX-D1F63R
	161-0104-00			1	CA ASSY,PWR:3,18 AWG,98 L,250V/10AMP,98 INCH,RTANG,IEC320,RCPT X STR,NEMA 15-5P,W/CORD GRIP	S3109	ORDER BY DESCRIPTION
	161-0104-06			1	CA ASSY,PWR:3,1.0MM SQ,250V/10A,2.5 METER,RTANG,IEC320,RCPT,EUROPEAN,SAFTEY CONTROLLED	TK1373	ORDER BY DESCRIPTION
	161-0104-07			1	CA ASSY,PWR:3,1.0MM SQ,240V/10A,2.5 METER,RTANG,IEC320,RCPT X 13A,FUSED,UK PLUG,(13A FUSE)	TK2541	ORDER BY DESCRIPTION
	161-0104-05			1	CA ASSY,PWR:3,1.0MM SQ,250V/10A,2.5 METER,RTANG,IEC320,RCPT,AUSTRALIA,SAFTEY CONTROLLED	TK1373	161-0104-05

## Replaceable parts List (cont.)

Fig. & index number	Tektronix part number	Serial no. effective	Serial no. discont'd	Qty	Name & description	Mfr. code	Mfr. part number
	161-0104-08			1	CA ASSY,PWR:3,18 AWG,250/10A,98 INCH L,RTANG,IEC320,RCPT X STR,NEMA 6-15P,US,SAFTEY CONTROLL	2W733	161-0104-08
	161-0167-00			1	CA ASSY,PWR:3,0.75MM SQ,250V/10A,2.5 METER,RTANG,IEC320,RCPT,SWISS,NO CORD GRIP,SAFTEY CONTR	S3109	ORDER BY DESCRIPTION
	161-0066-00			1	CA ASSY,PWR:3,18 AWG,250V/10A,98 INCH,STR,IEC320,RCPT X NEMA 5-15P,US,SAFTEY CONTROLLED	0B445	ECM-161-0066-00
	161-0066-09			1	CA ASSY,PWR:3,0.75MM SQ,250V/10A,99 INCH,STR,IEC320,RCPT,EUROPEAN	2W733	ORDER BY DESCRIPTION
	161-0066-10			1	CA ASSY,PWR:3,1.0 MM SQ,250V/10A,2.5 METER,STR,IEC320,RCPT X 13A,FUSED UK PLUG(13A FUSE),UNI	TK2541	ORDER BY DESCRIPTION
	161-0066-11			1	CA ASSY,PWR:3,1.0MM SQ,250V/10A,2.5 METER,STR,IEC320,RCPT,AUSTRALIA	80126	ORDER BY DESCRIPTION
	161-0066-12			1	CA ASSY,PWR:3,18 AWG,250V/10A,98 INCH,STR,IEC320,RCPT X NEMA 6-15P,US,SAFTEY CONTROLLED	S3109	ORDER BY DESCRIPTION
	161-0154-00			1	CA ASSY,PWR:3,1.0MM SQ,250V/10A,2.5 METER,STR,IEC320,RCPT,SWISS,SAFTEY CONTROLLED	5F520	86515030





# Index





# Index

## A

- Accessories
  - optional, 7-2
  - standard, 7-1
- Adjustment, after repair, 4-68
- Adjustment interval, xiii

## B

- Backplane, 3-1
- Backplane board
  - installing, 4-36
  - removing, 4-36
- BIOS
  - setup error messages, 4-65
  - updating, 4-67
  - verifying version of, 4-67
- Bottom cover, removing and installing, 4-19
- Bypassing front panel controls, 4-60

## C

- CD ROM drive, 2-3
  - installation, 4-18
  - removing, 4-18
- Certification interval, xiii
- Chassis, 3-1
- Cleaning and inspection, 4-2
  - exterior, 4-2
  - flat panel display, 4-3
  - interior, 4-2
- COM port, 2-5
- Controller board, 3-1
  - installing, 4-34
  - removing, 4-33
- Cord wrap feet
  - installing, 4-31
  - removing, 4-31
- Cover, bottom, removing and installing, 4-19
- Cover, left side, installing, 4-22
- Cover, right side, installing, 4-22
- Cover, top, removing and installing, 4-20
- CRT options, 5-1

## D

- Diagnostics, 2-6

- controller, 4-58
- mainframe, 4-59
- PC, 4-58
- power on, 4-58
- QA+Win32, 4-59
- start up sequence, 4-68
- start up sequence tree, 4-69
- Diagrams, mainframe block diagram, 6-1
- Dimensions, portable mainframe, 1-10
- Documentation, manual structure, xi

## E

- Elastomeric keypad
  - installing, 4-39
  - removing, 4-39
- Email address
  - Service, xii
  - Tektronix, xii
- Equipment required
  - to service, 4-6
  - to service TLA 714, 4-42
  - to troubleshoot, 4-56
- ESD, preventing, 4-1

## F

- Fan tray, rear chassis
  - installing, 4-27
  - removing, 4-26
- Fans, individual
  - installing, 4-28
  - removing, 4-28
- Feet
  - installing cord wrap feet, 4-31
  - installing rear feet, 4-30
  - removing cord wrap feet, 4-31
  - removing rear feet, 4-30
- Fixed hard disk drive, 2-3
  - installing on TLA 714, 4-49
- Fixed hard disk drive assembly, TLA 714, 4-41
- Flat panel display
  - cleaning, 4-3
  - installing, 4-13
  - installing on TLA 714, 4-51
  - removing, 4-12
  - removing from TLA 714, 4-47
- Floppy disk drive, 2-3

- installing, 4-14
- removing, 4-14
- Front panel control assembly
  - installing, 4-17
  - removing, 4-15
- Front panel control board
  - installing, 4-38
  - removing, 4-36
- Front panel controller board, 3-1
- Front panel controls, bypassing, 4-60
- Front panel interface board, 3-1
  - installing, 4-15
  - removing, 4-14
- Front panel knobs, removing and replacing, 4-17
- Fuse
  - installing, 4-23
  - removing, 4-23

## G

- General safety summary, vii
- Glide point device, 2-2
- Glidepoint assembly, removing and installing, 4-38

## H

- Handle
  - installing, 4-32
  - removing, 4-32
- Hard disk drive
  - fixed, 2-3
  - removal, 4-8
  - removal for TLA 714, 4-44
  - replaceable, 2-3
- Hard disk drive assembly, TLA 714, 4-41

## I

- I/O and memory hardware, 2-1
- Inspection and cleaning, 4-2
  - exterior, 4-2
  - flat panel display, 4-3
  - interior, 4-2
- Installation procedures
  - equipment required, 4-6
  - equipment required for TLA 714, 4-42
  - general instructions, 4-5
    - TLA 714, 4-42

## K

- Keyboard port, 2-2
- Keypad
  - installing, 4-39
  - removing, 4-39

## L

- LCD display
  - installing, 4-13
  - installing on TLA 714, 4-51
  - removing, 4-12
  - removing from TLA 714, 4-47
- Line cord
  - installing, 4-23
  - removing, 4-23
- Logic analyzer cart, 5-1
- LPT port, 2-5

## M

- Main memory, SO DIMM module, 4-35
- Mainframe
  - block diagram, 6-1
  - CD ROM drive, 2-3
  - COM port, 2-5
  - description, 2-1
  - diagnostics, 2-6, 4-59
  - exploded view, 4-7
  - external connectors, 2-3
  - fixed hard disk drive, 2-3
  - floppy disk drive, 2-3
  - glide point device, 2-2
  - installation, 2-1
  - keyboard and knobs, 2-2
  - keyboard port, 2-2
  - LCD display, 2-2
  - LPT port, 2-5
  - memory, 2-3
  - mouse port, 2-2
  - PC card port, 2-2
  - QA+Win32 diagnostics, 4-59
  - removing the hard disk drive, 4-8
  - replaceable hard disk drive, 2-3
  - SVGA port, 2-4
  - USB port, 2-2
- Maintenance, 4-1

- inspection and cleaning, 4-2
- preparation, 4-1
- preventing ESD, 4-1

#### Manual

- conventions, xi
- structure, xi

Mechanical chassis, 3-1

Mechanical parts list, 7-2

#### Memory

- installing, 4-35
- removing SO DIMM module, 4-35
- SO DIMM, 2-3
- SO DIMM module, 4-35

#### Module

- packaging, 4-71
- shipping information, 4-71

Module servicing, 7-3

Monitor options, 5-1

Mouse port, 2-2

## N

Network interface card, 5-1

NIC, option for, 5-1

## O

Online help, 2-6

Optional accessories, 7-2

Options, 5-1

- logic analyzer cart, 5-1
- monitor, 5-1
- network interface card, 5-1
- power cords, 5-1
- service, 5-1, 5-2

## P

Packaging, 4-71

Packing instructions, 4-71

Parts list, 7-2

- abbreviations, 7-4
- manufacturer cross reference, 7-4
- part number revision level, 7-3
- using, 7-3

PC card port, 2-2

PCMCIA port, 2-2

Power cord

- identification, 5-3
- installing, 4-23
- options, 5-1

- removing, 4-23

Power supply, 3-1

- checking voltages, 4-60
- installing, 4-26
- removing, 4-25

Preventing ESD, 4-1

Product description, 1-1

## Q

QA+Win32

- running, 4-59
- using for diagnostics, 4-59

## R

Removal procedures

- equipment required, 4-6
- equipment required for TLA 714, 4-42
- general instructions, 4-5
  - TLA 714, 4-42

Repackaging instructions, 4-71

Replaceable hard disk drive, 2-3

Replaceable parts list, 7-2

- abbreviations, 7-4
- manufacturer cross reference, 7-4
- part number revision level, 7-3
- part ordering information, 7-2
- using, 7-3

ResMan32

- command line options, 4-63
- program output, 4-64

Resource manager program, see: ResMan32, 4-63

RMA, 4-71

## S

Safety, vii, ix

- general safety summary, vii
- service safety summary, ix
- symbols and terms, viii
- to avoid fire, vii
- to avoid personal injury, vii

Service

- agreements, xiv
- calibration and repair, xiv
- contacting Tektronix, xii
- for more information, xiv
- module repair and return, 7-3
- module servicing, 7-3
- offerings, xiv

- on demand, xiv
  - options, xiv, 5-1
  - returning for service, 4-71
  - self service, xiv
  - strategy for, xiii
  - warranty repair, xiv
  - world wide web address, xiv
  - Service safety summary, ix
  - Shipping instructions, 4-71
  - Side cover, left, removing, 4-21
  - Side cover, right, removing, 4-22
  - SO DIMM, installing, 4-35
  - SO DIMM module, removing, 4-35
  - Specifications
    - characteristics tables, 1-2
    - portable mainframe dimensions, 1-10
    - portable mainframe weight, 1-10
    - product description, 1-1
  - Standard accessories, 7-1
  - Startup sequence, TLA 700, 4-68
  - Strategy for servicing, xiii
  - SVGA port, 2-4
  - System problems, isolating, 4-62
- T**
- Tektronix
    - email address, xii
    - how to contact, xii
    - mail address, xii
    - World Wide Web address, xii
  - Theory of operation, 3-1
  - backplain, 3-1
  - controller board, 3-1
  - front panel controller board, 3-1
  - front panel interface board, 3-1
  - power supply, 3-1
  - TLA 700 startup sequence, 4-68
  - TLA 714 mainframe, removing the hard disk drive, 4-44
  - Tools required
    - to service, 4-6
    - to service TLA 714, 4-42
  - Top cover, removing and installing, 4-20
  - Trim ring
    - installing, 4-11, 4-51
    - removing, 4-10, 4-46
  - Troubleshooting
    - adjustment after repair, 4-68
    - common problem checklist, 4-54
    - controller diagnostics, 4-58
    - eliminating other problems, 4-56
    - equipment required, 4-56
    - fault isolation procedure, 4-56
    - isolating system problems, 4-62
    - power on diagnostics, 4-58
    - service level, 4-53
    - the mainframe, 4-56
    - troubleshooting tree, 4-57
    - verifying operation, 4-67
- U**
- USB port, 2-2



