

Owners manual

Öhlins motocross front forks FG 012 GasGas



Including:
**Setting up
your bike**
Fine-tuning
**Service
the fork**
**General
handling
set-up**
**Technical
info**
**Spare parts
& tools**



Öhlins motocross front forks FG 012 GasGas

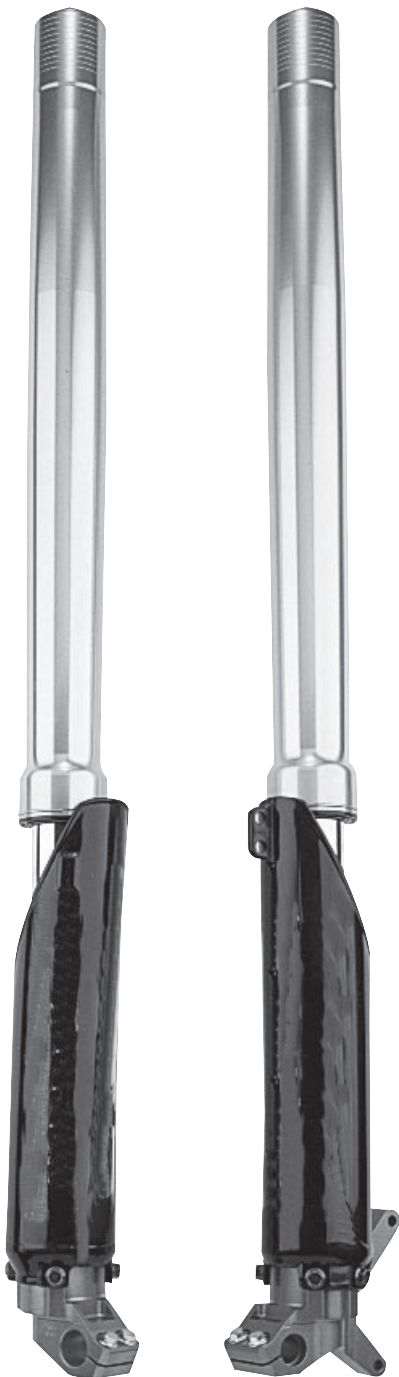

Contents

Safety signals	2
Introduction	3
Design	3
Before you start	3
Marking	3
Recommended settings	3
Mounting instructions	4
Setting up the bike	4
Checking front sag	4
Checking rear sag	4
Checking front ride height	5
Checking rear ride height	5
Fine-tuning the bike	5
Making adjustments	6
Oil level adjustment	6
Maintenance	6
General handling set-up	7
Preload adjustment	8
Changing springs	9
Dismantling the front fork	10
Assembly of the front fork	11
Service tools	13
Technical specifications	13
Spare parts	14

Safety signals

Important information concerning safety is distinguished in this manual by the following notations.



The Safety alert symbol means: **Caution!** Your safety is involved.

⚠ WARNING!

Failure to follow warning instructions could result in **severe or fatal injury** to anyone working with, inspecting or using the suspension, or to bystanders.

CAUTION!

Caution indicates that special precautions must be taken to avoid damage to the suspension.

NOTE!

This indicates information that is of importance with regard to procedures.

Kit contents

Before installing the front fork, please check the contents of the kit, listed in the mounting instruction. If anything is missing, contact your Öhlins dealer.

NOTE!

During storage and transportation, especially at high ambient temperature, the oil and grease used for assembling may run out inside the packing and damage the expanded polystyrene packing material. This is not unusual and is in no way detrimental to the shock absorber.

© Öhlins Racing AB.
All rights reserved.

Any reprinting or unauthorised use without the written permission of Öhlins Racing AB is prohibited.
Printed in Sweden.

Introduction

Öhlins Racing congratulates you on your choice of front fork for your motocross bike.

All Öhlins products are designed with just one aim; to win races. To design a winner you need a concept starting with a unique know-how. You add engineering skill, precision and the best material available. The result is quality, endurance and winning performance.

Your new Öhlins front fork is developed from experience gained during years of successful cooperation with the World Championship winning works motocross teams.

Spring rates and damping forces are developed just for your bike. The design and the settings are consequently the results of extensive testing and no guesswork!

Öhlins shock absorbers and front forks have dominated the motorcycle scene for several years and have captured more World Championship titles than any other brand, over 80 titles!

A well equipped network of authorised Öhlins service centres around the world, with specially trained mechanics, can help you with personally tuned settings, service, repairs and spare parts.

Design

Öhlins new up-side-down (USD) front fork is designed to combine the advantages of comfortable, safe conventional forks and rigid, light USD forks. The result is a unique combination of being rigid, precise in corners and during hard braking yet comfortable, forgiving when “over-landing” and in big bumps.

Your new Öhlins USD front fork has aluminium outer legs and 46 mm steel inner legs, with a polished surface for lowest possible friction.

The legs also feature a completely new bushing design with fixed and one sliding bushing.

The new USD fork features the Öhlins championship winning cartridge damping system.

The fork is fully adjustable with external adjuster for compression- and rebound damping.

The compression adjuster is located at the bottom of the fork leg, fig 1, the rebound adjuster at the top, fig 2.

Spring preload is adjusted with washers, fig 3, and optional springs are available to suit different tracks and riders.

In the legs there are also “air-springs” (the air trapped above the oil) that work together with the “real” spring. You adjust the air-spring by raising or lowering the oil level in the legs.

By using different combinations of

springs and air-springs you can alter the characteristic of the fork. For example, a soft spring in combination with a small air-spring (high oil level) makes the fork progressive, see “Fine-tuning the bike”.

Before you start

⚠ WARNING!

Installing a front fork, that is not approved by the vehicle manufacturer, may affect the stability of your vehicle. Öhlins Racing AB cannot be held responsible for any personal injury or damage whatsoever that may occur after fitting the front fork. Contact an Öhlins dealer or other qualified person for advice.

Öhlins Racing AB can not be held responsible for any damage whatsoever to front fork or vehicle, or injury to persons, if the instructions for fitting and maintenance are not followed exactly. Similarly, the warranty will become null and void if the instructions are not adhered to.

⚠ WARNING!

Please study and make certain that you fully understand all the mounting instructions and the owner’s manuals before handling this front fork kit. If you have any questions regarding proper installation procedures, contact an Öhlins dealer or other qualified person.

⚠ WARNING!

The vehicle service manual must be referred to when installing the Öhlins front fork.

NOTE!

Öhlins products are subject to continual improvement and development. Consequently, although these instructions include the most up-to-date information available at the time of printing, there may be minor differences between your suspension and this manual. Please consult your Öhlins dealer if you have any questions with regard to the contents of the manual.

Marking

All Öhlins front forks are marked. You will find the part number on the inside of the fork bottom.

Your Öhlins front fork has the following marking:

FG 012 GasGas

Recommended settings

The front fork in your kit is adjusted to the Öhlins recommended setting for your bike, see “Making adjustments”. We advise you to use this as your start setting.

Compression adjuster

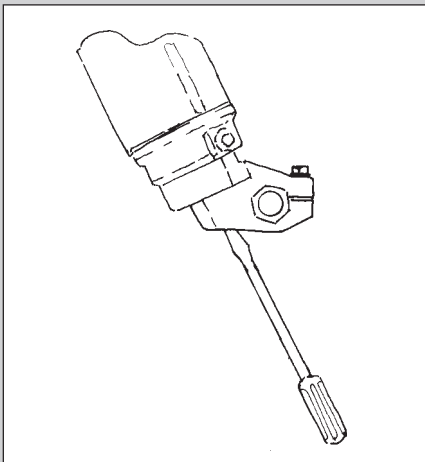

1. The compression adjuster is located at the bottom of the fork leg.

Rebound adjuster

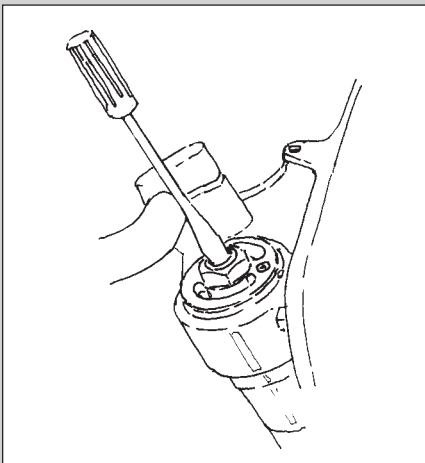

2. The rebound adjuster at the top of the fork leg.

Preload adjustment

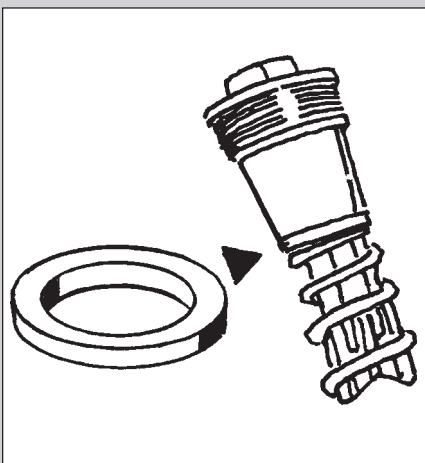

3. Spring preload is adjusted with washers and optional springs are available.

Mounting instructions

⚠ WARNING

1. It is advisable to have an Öhlins dealer or a qualified mechanic to fit your front fork kit.
2. To install the kit you need your motorcycle's work shop manual.
3. When working on your motorcycle, support it securely so it does not fall over.

The Öhlins front fork is designed to fit your bike's standard triple clamps and to use the standard brake components and wheel.

A

Put your bike on a stand and remove the front wheel, the front brake components and the fork legs from the bike according to the work shop manual.

CAUTION!

1. The outer legs, both left and right, should be adjusted evenly in the fork crown.
2. The Öhlins fork legs feature grooves on top of the outer fork legs to make adjustment of the fork height easier. The distance between the grooves is 4 mm.

B

Fit the Öhlins front fork legs. For recommended front fork mounting height see mounting instruction.

C

Fit the brake components and the front wheel according to the work shop manual.

D

Tighten all screws. For maximum torque, please see your bike's work shop manual.

Setting up the bike

We would like to give you some basic guidelines how to set up your bike with your new Öhlins front fork.

However, remember that the front fork is just one part of your motorcycle and to get the fork to work properly the whole motorcycle has to be set up according to standards.

Please follow the instructions below, see also your bike's work shop manual.

Your new front fork is dialled-in to the Öhlins recommended settings for your bike. The same goes for the rear shock absorber if you are using an Öhlins unit.

All settings are based on a bike and a rider of normal weight.

Depending on your own and your bike's actual weight minor differ-

ences, between the Öhlins recommended settings and the settings you achieve, may occur. Therefore, it is always wise to start the setting up by checking!

The sag effects not just only the suspension but also the rake of the front fork and therefore the overall behaviour of the bike.

Checking front static sag

A

Put your bike on a stand. Arrange the stand so that the front wheel is off the ground and the front fork fully extended.

B

Measure the distance between the upper fork crown and the front wheel axle, fig 4 distance A. Make a note of the measurement.

C

Remove the stand. With the wheels on the ground measure the distance again, fig 4 distance B. The difference of the two measurements is the static sag.

D

The static sag should be 30 ± 10 mm.

E

If the static sag is less than 20 mm, you need to reduce spring preload. If the static sag is more than 40 mm, you need to increase spring preload.

F

Spring preload is adjusted with spacers, see "Preload adjustment" on page 8. Maximum allowed spring preload is 13 mm.

If you need to preload the springs more than 13 mm, we recommend you to change to a "stiffer" spring.

Checking rear static sag

A

Put your bike on a stand. Arrange the stand so that the rear wheel is off the ground and the rear suspension fully extended.

B

Measure the distance between the rear wheel axle and a point near the rear end of the seat, for example a seat bolt, fig 4 distance A. Make a note of the measurement.

C

Remove the stand. With the wheels on the ground measure the distance again, fig 4 distance B. The difference of the two measurements is the static sag.

Setting up the bike

4. Checking sag and ride height.

Front sag:
A - B = 30 ± 10 mm.

Front ride height:
A - C = 50 ± 10 mm.

Rear sag:
A - B = 45 ± 10 mm.

Rear ride height:
A - C = 115 ± 10 mm.



NOTE!

Refer to mounting instruction for more specific set-up data.

D

The static sag should be 45 ± 10 mm.

E

If the static sag is less than 35 mm, you need to reduce spring preload. If the static sag is more than 55 mm, you need to increase spring preload.

F

Adjust the spring preload according to your rear shock mounting instruction.

Checking front ride height

A

Put your bike on a stand. Arrange the stand so that the front wheel is off the ground and the front fork fully extended. Measure the distance between the upper fork crown and the front wheel axle, fig 4 distance A. Make a note of the measurement.

B

Race dressed sit on the bike, straight above the foot pegs, with the feet barely touching the ground. Have somebody to measure between the same point as before, fig 4 distance C.

C

The difference of the two measurements should be 50 ± 10 mm.

CAUTION!

Do not try to alter ride height by altering the spring preload. New springs are needed.

D

If you need to change the springs, see "Changing springs" on page 9.

E

Stiffer springs are needed if the difference is more than 60 mm. Softer springs if the difference is less than 40 mm. Consult your Öhlins dealer for the right rate.

Checking rear ride height

A

Put your bike on a stand. Arrange the stand so that the rear wheel is off the ground and the rear suspension fully extended. Measure the distance between the rear wheel axle and a point near the rear end of the seat, for example a seat bolt, fig 4 distance A. Make a note of the measurement.

B

Race dressed sit on the bike, straight above the foot pegs, with the feet barely touching the ground. Have somebody to measure between the same point as before, fig 4 distance C.

C

The difference of the two measurements should be 115 ± 10 mm.

CAUTION!

Do not try to alter ride height by altering the spring preload. A new spring is needed.

D

A stiffer spring is needed if the difference is more than 110 mm. A softer spring if the difference is less than 90 mm. Consult your Öhlins dealer for a spring of the right rate.

Should you still experience excessive bottoming or that the bike feels much too stiff and suspension travel is not fully used, harder/softer than normal springs may be needed for the track you are testing on.

Consult your Öhlins dealer for advice!

Fine-tuning the bike

Learning how to use the adjusters will take time but you quickly appreciate them once you know the tricks. Even the specialists sometimes need a specialist!

With the adjusters you optimize the suspension for your riding style and the track you are competing on.

The same basic guide lines goes for both the front fork and the rear shock absorber.

Too much compression damping will give you a harsh ride as your bike "jumps" along the track.

With too much rebound damping your bike will have difficulties with several bumps in a row. The suspension will not extend fast enough between bumps, your bike will ride lower and lower and eventually the suspension will bottom!

External adjusters

On the Öhlins front fork the adjusters are bleed valves, totally separated from each other.

The compression bleed valve controls the flow in the cartridge tube during the compression stroke, the rebound bleed valve the flow during the rebound stroke.

CAUTION!

Using too much force when closing the adjusters will destroy important sealing surfaces.

Air spring

5. A change in oil level will effect the damping forces, not in the early stage of fork travel but a great deal in the later stage.

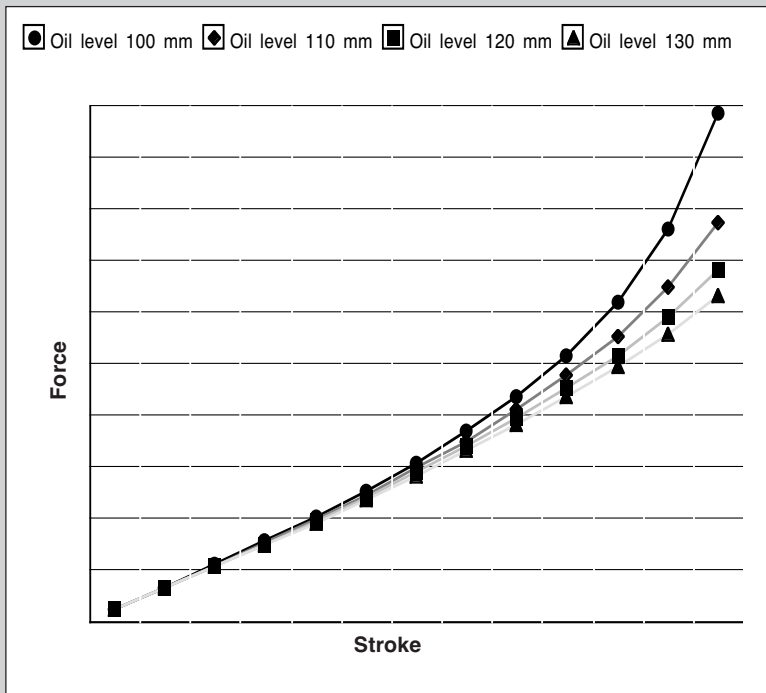

Oil level

6. Oil level is measured from the top of the outer leg, with the top nut off, the fork fully compressed and no preload washer nor spring installed.

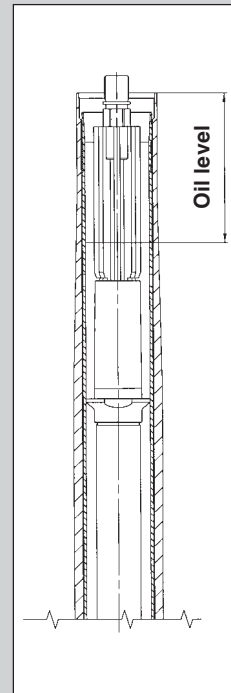

Both the adjusters have a normal right-hand thread.

Click position zero (0) is when the adjusters are turned clockwise to fully closed.

The adjustment range, from fully closed until maximum open valve (anticlockwise), is 20 clicks.

In order not to click in the wrong direction; always first close the adjuster, then dial-in the new setting.

Making adjustments

To make improvements using the adjusters, it is important to understand the function of the front fork and the shock absorber and through testing learn how they effect the handling of your bike.

Make sure that you have the correct springs and the correct spring preload before making any adjustments. And always start with the Öhlins recommended settings:

NOTE!

See mounting instruction for recommended settings.

NOTE!

Higher click numbers give less damping force.

When making adjustments; keep notes, make adjustments one at a time... and in small steps.

The adjusters should normally not be adjusted in steps of more than 2 clicks at a time and not outside the usable click range.

When you think you have made an improvement, go back to what you started with and double check to be sure. Pay attention to changes in conditions like tires, temperatures etc.

In general, compression damping changes should be used to influence the bike's stability and response, while rebound damping changes should be used to influence comfort and traction.

When you need more damping force, you should mainly try to increase compression damping and use as little rebound damping as possible.

This usually means that you gain comfort and performance in handling.

Oil level adjustment

As the air trapped between the oil and the top nut acts as an air-spring, a change in oil level will effect the damping forces. Not in the early stage of fork travel, but a great deal in the later stage.

A general description of how the oil level/air-spring effects the damping forces are shown in fig 5.

The air-spring gives the Öhlins USD fork a progressive spring rate, preventing it from bottoming out hard.

By using different combinations of springs and oil levels/air-springs you can alter the characteristic of the fork and tailor it to suit different tracks and conditions.

CAUTION!

The oil level must be the same in both front fork legs. Riding a bike with different oil levels will cause instability.

When the oil level is raised:

The air-spring in the later half of travel is strong, and thus the front fork hard.

When the oil level is lowered:

The air-spring in the later half of travel is soft, and thus the front fork soft.

CAUTION!

Adjust the oil level with the fork leg fully compressed and no preload washer nor spring installed.

NOTE!

See mounting instruction for recommended oil level.

The oil level is measured from the top of the outer leg, with the top nut off, see fig 6.

A change in oil level should be made in small steps. We recommend a change of 5 mm at a time and not outside the range of 90-130 mm.

Maintenance

Telescopic front forks depend on a smooth, friction free action.

Make sure your forks are regularly serviced.

Do not use strong solvents, such as brake cleaner, to clean the front forks. This will dry out the seals and the steel tubes and cause friction or leakage.

After every race:

Clean externally and spray with an all-purpose oil after washing with detergent.

Check externally for damage.

Put a little Öhlins green grease (148-01) on the steel tubes and work it in by pushing the fork up and down.

Every 20 hours:

Dismantle the fork and check all parts for wear and damage, replace if necessary, see page 10.

General handling set-up

A

Front end falls into the curves (over-steering) especially in sand.
Steep front fork angle. Front end too low in comparison to rear end.

- ✓ Increase the front fork compression damping.
- ✓ Change to harder springs.
- ✓ Lower fork leg approximately 5 mm in the triple clamp.

B

Front end "ploughs", understeers.
Shallow front fork angle. Front end too high in comparison to rear end.

- ✓ Decrease the front fork compression damping.
- ✓ Raise the fork legs approximately 5 mm in the triple clamp.
- ✓ Change to softer fork springs.

C

Front end unstable at high speed, unstable when accelerating out of curves.

- Front fork angle too steep. Front end too low in comparison to rear end.
- ✓ Lower the fork legs approximately 5 mm in triple clamp.
 - ✓ Change the front fork springs to harder ones.

D

Front end unstable during deceleration.

- Front fork angle too steep during braking. Front end too low or rear end too high.
- ✓ Increase the oil level in the front fork.
 - ✓ Change to harder fork springs.
 - ✓ Increase the front fork compression damping.

Front suspension.

A

Front fork travel is not used to its full capacity. Harsh feeling, front wheel grip is not satisfactory in bumpy turns.

- Suspension too hard.
- ✓ Decrease the front fork compression damping.
 - ✓ Change to softer springs.

B

Suspension bottoming, too soft during entire travel.

- Spring too weak or compression damping too soft.
- ✓ Increase oil level 5 mm.
 - ✓ Increase compression damping.
 - ✓ Change to stiffer springs.

C

Suspension bottoming, but can

handle smaller bumps.

- Damping force not progressive enough.
- ✓ Increase the oil level.

D

Can handle smaller bumps but is too hard during the last part of the travel.

- Damping force is too progressive.
- ✓ Decrease the oil level.

E

Front end feels low, initially feels soft, but is not bottoming.

- The initial spring rate is too soft or spring preload is too low.
- ✓ Increase the spring preload.

E

Feels harsh over small bumps, but using full wheel travel.

- Too much spring preload or too much compression damping.
- ✓ Increase the oil level or change to softer springs.
 - ✓ Decrease the compression damping.
 - ✓ Decrease the spring preload.
 - ✓ Clean the oil seals and scrapers. Use Öhlins grease 148-01 for regreasing.

F

Can handle the first in a series of bumps but feels hard after a few more bumps. Frontal grip insufficient in rough and bumpy turns.

- Too much rebound damping.
- ✓ Decrease the rebound damping.

G

Front end rebound too fast after a bump. Front wheel grip insufficient in bumpy curves.

- Not enough rebound damping, or too much spring preload
- ✓ Increase the rebound damping.
 - ✓ Decrease the spring preload.

Rear suspension.

A

Rear suspension stroke is not used to its capacity. Suspension feels harsh. Traction not satisfactory in bumpy curves.

- Suspension hard in general or too much compression damping, too much spring pre-load.
- ✓ Decrease the compression damping.
 - ✓ Decrease the spring preload.
 - ✓ Change to softer spring.

B

Suspension is bottoming, feels

soft during the entire wheel travel.

- Spring too soft, compression damping too low.
- ✓ Increase the compression damping.
 - ✓ Change to harder spring.

C

Suspension is bottoming, feels harsh and sags down too much with the rider in the saddle.

- Spring too soft or compression damping too low.
- ✓ Increase the spring preload, check ride height. 95 +/- 5 mm.
 - ✓ Change to harder spring if the load is more than 100 mm.
 - ✓ Increase compression damping.

D

Rear wheel jumps over small bumps during deceleration or when going downhill. Traction not satisfactory in washboard curves.

- Too much spring preload, as the spring is probably too soft, will cause the spring to extend too fast.
- ✓ Change to a harder spring in order to achieve a balanced position using less spring preload.
 - ✓ Check the static sag and ride height.

E

Rear end kicks up over bumps with sharp edges, but can handle bumps with round edges.

- Compression damping too hard.
- ✓ Decrease the compression damping.

F

Rear end becomes too low in series of bumps. Traction not satisfactory in washboard type curves or when decelerating on washboard ground.

- Rebound damping too slow.
- ✓ Decrease the rebound damping.

G

Rear end very unstable. Shock does not respond to adjustments.

- Shock damping is gone, caused of low gas pressure, bad oil is used, or components are broken in the shock absorber. Service is needed.
- ✓ Gas filling required.
 - ✓ Change shock oil.
 - ✓ Repair or change the shock absorber.

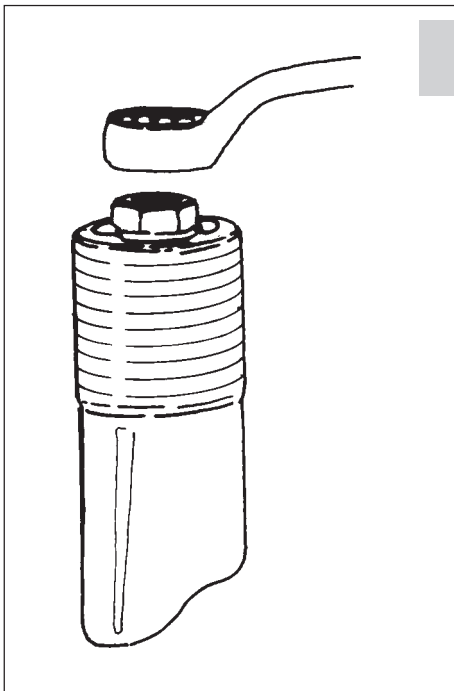

a

Preload adjustment

Put the bike on a stand and loosen the screws in the fork top crown that hold the fork legs.

NOTE

On most MX-bikes you have to take off the handle bar before you can unscrew the top cap.

Unscrew the top cap, use a 24 mm wrench.

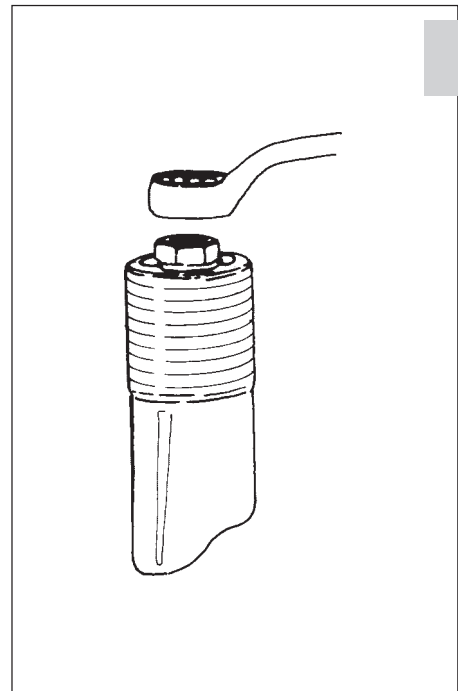

a

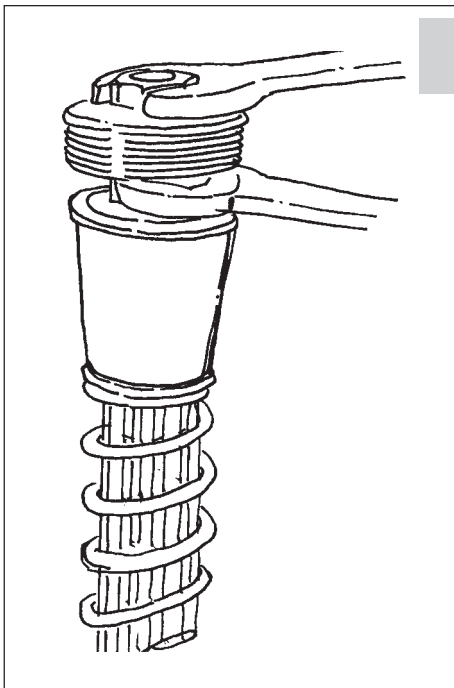

b

Put a box under the front wheel so that the springs are visible.

Remove the top cap from the damper rod extender. Use a 16 and 24 mm wrench.

Remove the spring support.

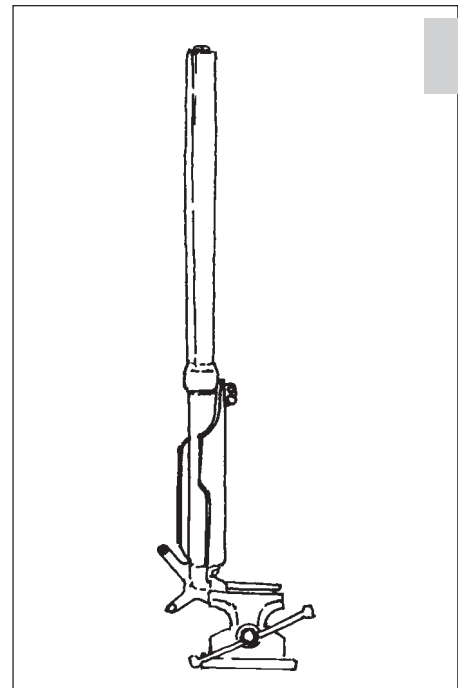

b

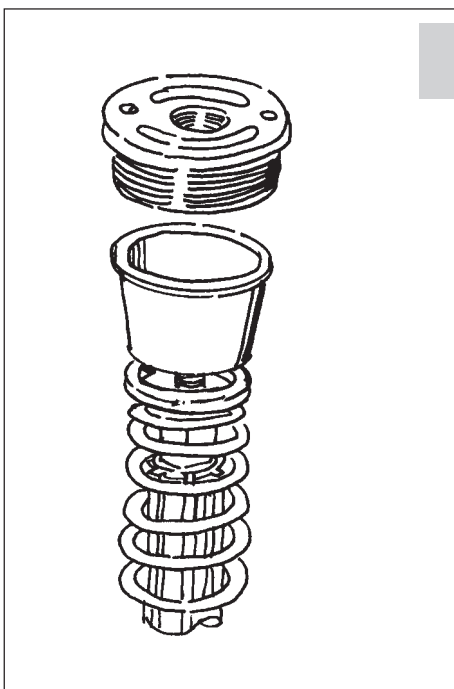

c

Install a new preload spacer to achieve the right static sag.

Fit the spring support, top cap and the handle bar.

Tighten all screws.

For tightening torques, please see your bike's work shop manual.

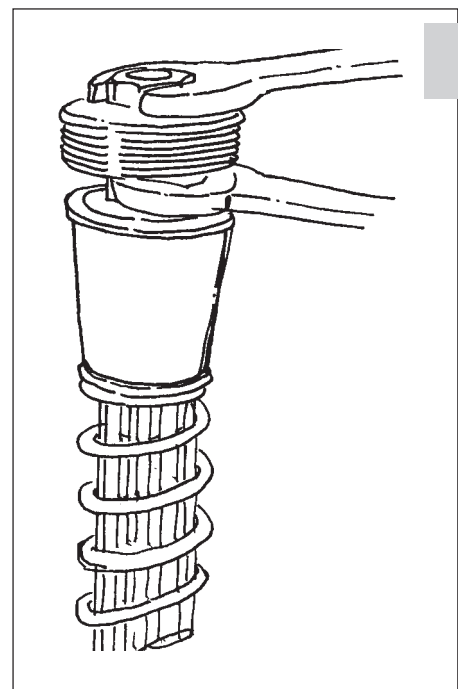

c

Changing springs

Loosen the screws that hold the fork legs in the upper fork crown.

With the fork leg still tightened in the lower fork crown unscrew the top cap, use a 24 mm wrench.

Loosen the screws that hold the fork legs in the lower fork crown.

Remove the fork legs from the motorcycle.

Fasten the fork leg with soft jaws in a vice and loosen the lock nut on the top of the fork cap.

Remove the top cap from the damper rod extender, use a 16 and 24 mm wrench.

Remove the spring support, the preload washer and the spring.

For free spring length see technical information on page 13.

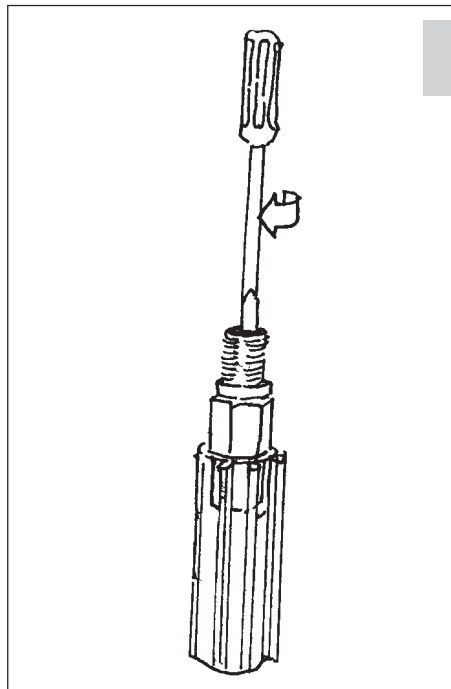

d

NOTE

Closing the compression- and the rebound valves will keep the damper rod extended making it easier to install the new spring.

Pull out the damper rod as far as possible.

Close the compression and the rebound valve (clockwise).

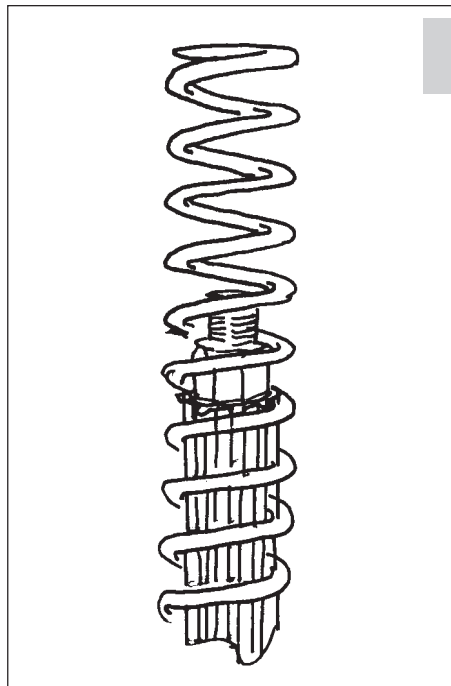

e

Install the spring and the preloadwasher.

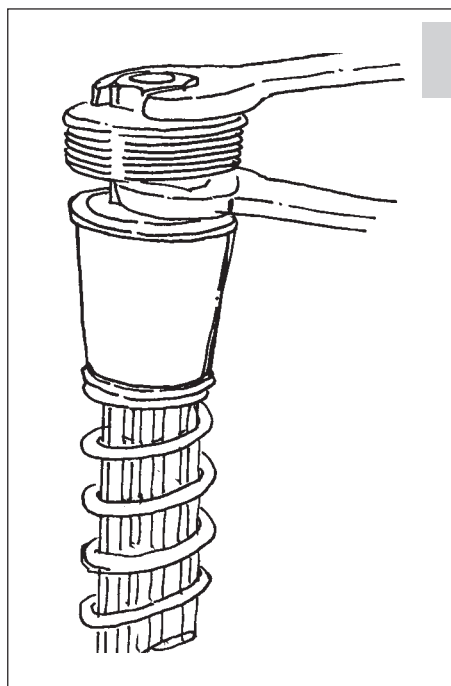

f

Install the spring support fork top cap and the lock nut.

Tighten the top cap and the lock nut against each other, use a 16 and 24 mm wrench.

Adjust the compression- and the rebound valves according to specification card.

Fit the fork legs on the motorcycle.

For tightening torques, please see your bike's work shop manual.

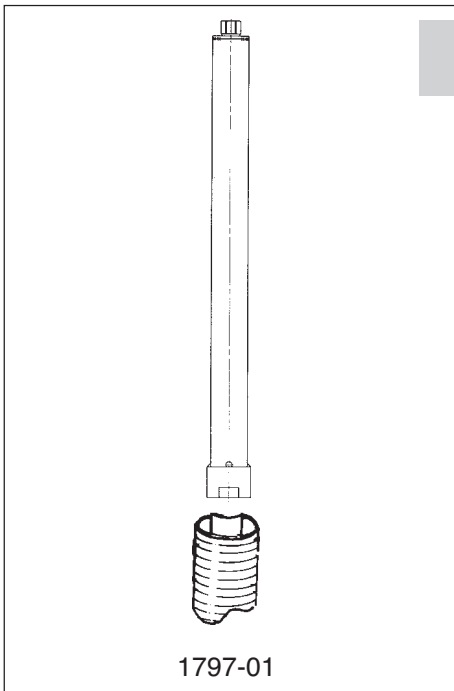

a

Dismantling

Perform steps a-d "Changing springs" on page 9.

Loosen the bush head, on top of the cartridge tube, with tool 1797-01.

Lift up the damper rod assembly and drain the oil.

Pull up the scraper with a screwdriver, release and remove the circlip.

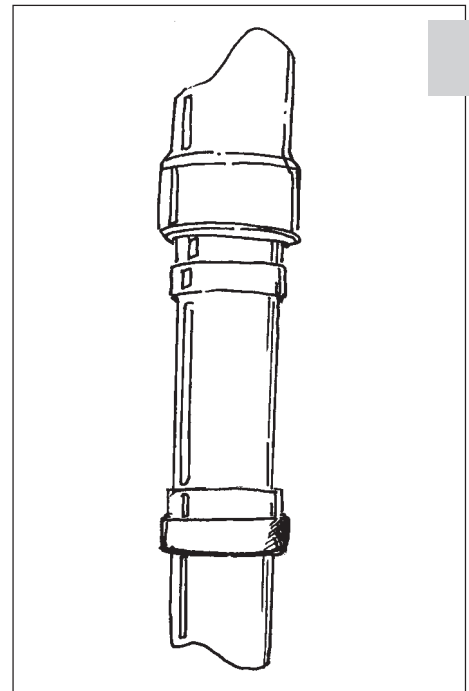

d

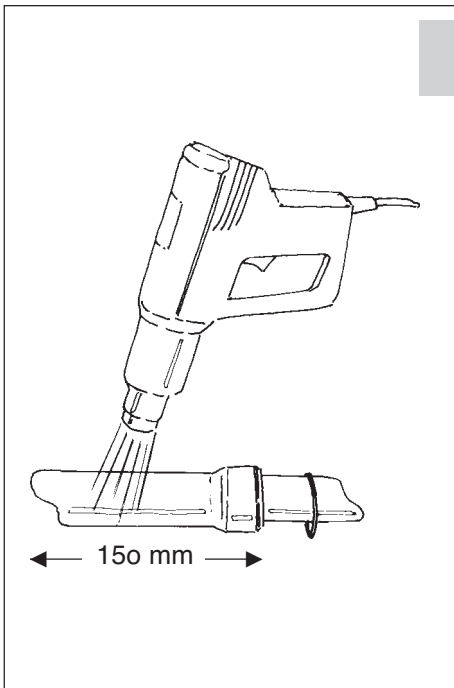

b

CAUTION!

The fork legs have two fixed and one sliding bushing. Be very careful when disassembling the fork legs.

Fasten the fork leg horizontally with soft jaws in a vice.

Use a hot air gun to warm up the outer leg where the bushings are located.

The first bushings is located at the bottom end of the outer leg, the second approximately 150 mm further up the leg.

Between them is a sleeve to maintain the distance.

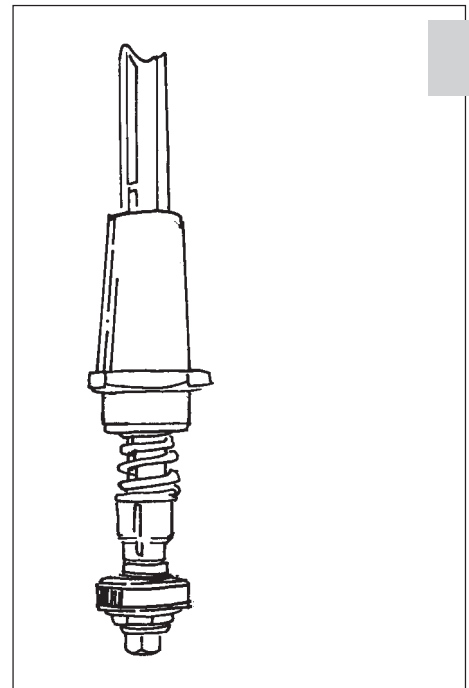

e

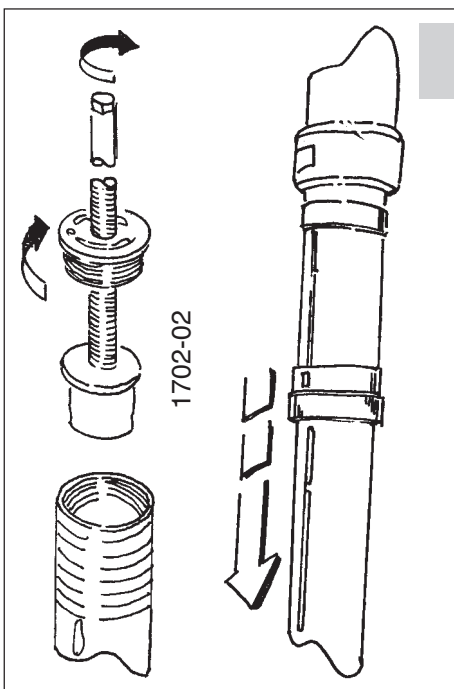

c

Use the special tool 1702-02 to remove the bushings.

Install the tool in the top of the inner steel leg.

Screw the top cap onto the tool and install the cap in the outer leg.

Rotate the tool to press out the bushings.

If tool 1702-02 not is available push the inner steel leg to the bottom and then pull it back quickly, so that the fork is topping out hard.

Repeat this procedure until the seal and the bushings can be pulled out from the outer leg.

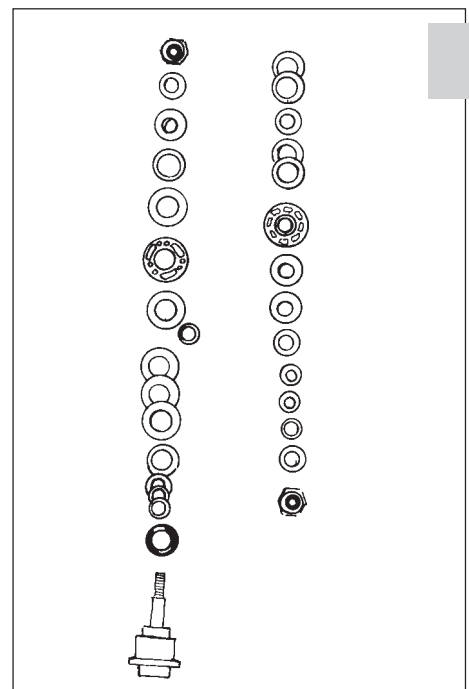

f

Remove the seals and bushings and check them for wear and damage.
Replace if necessary.

CAUTION!

When removing the oil seal and bushings use a small plastic bag to cover the bushing attachment groove and edges of the inner tube, to avoid damage to the seals.

Fasten the damper rod assembly with soft jaws in a vice.

Remove all parts from the damper rod.

NOTE

If the right order is lost, use the specification card as a guide.

Put them in the right order on the bench.

Inspect all parts for wear and damage, replace if necessary.

Clean all parts thoroughly.

Assemble the damper rod.

Remove the compression valve assembly from the fork bottom, use a 17 mm socket.

Fasten the valve assembly with soft jaws in a vice.

Remove all parts from the valve body.

Put them in the right order on the bench.

Inspect all parts for wear and damage, replace if necessary.

Clean all parts thoroughly.

Assemble the compression valve.

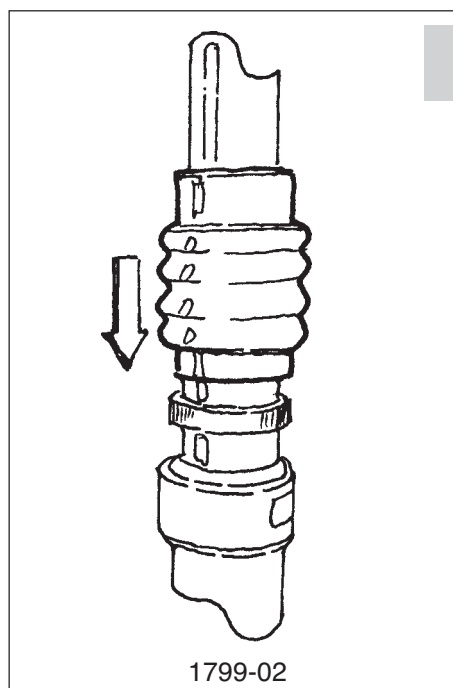
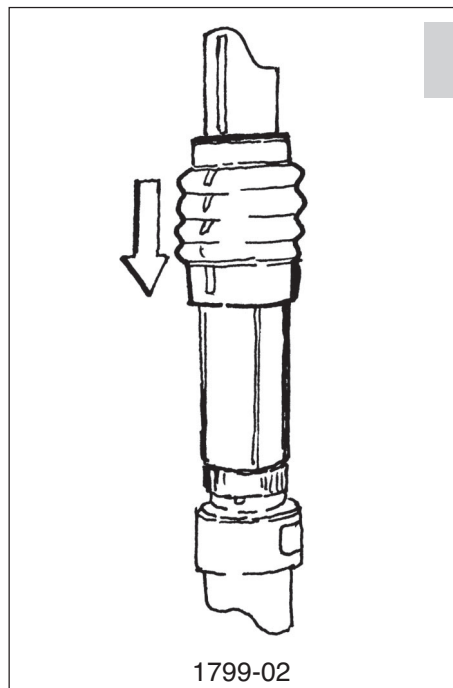
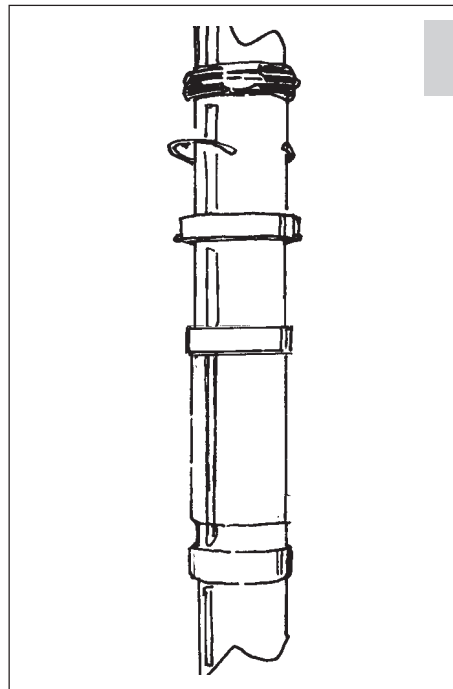

Assembling

Apply a thin layer of Öhlins green grease (148-01) on the scraper ring and on the sealing surface of the fork seal.

CAUTION!

When installing the oil seal and bushings use a small plastic bag to cover the bushing attachment groove and edges of the inner tube, to avoid damage to the seals.

Mount the scraper, circlip, fork seal, support ring and the bushings separated by the sleeve on the inner steel leg.

Fasten the outer leg with soft jaws in a vice.

Install the inner leg and mount the upper bushing with tool 1799-02, and the sleeve.

Mount the lower bushings.

Apply some Öhlins green grease on the seals.

Again, use tool 1799-02 turn it around to install the seal in the outer leg.

Install the circlip and the scraper.

CAUTION!

Make sure the circlip is fitted correctly into the groove in the outer leg.

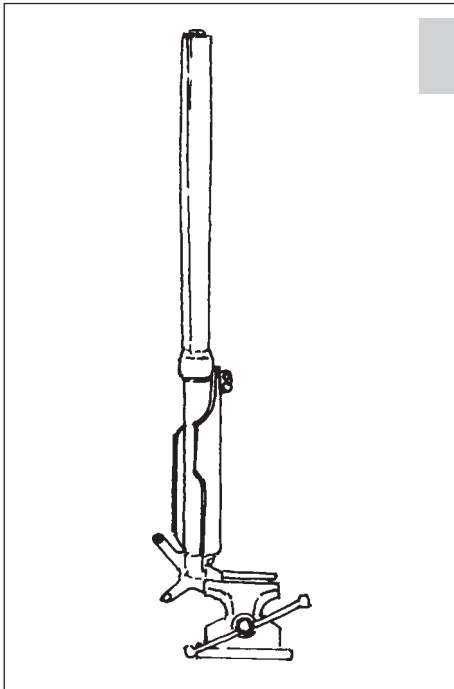

d

Fasten the fork leg, at the fork bottom, with soft jaws in a vice.

Install the compression valve assembly in the fork bottom.

Tightening torque 65 Nm.

Apply some front fork oil on the outer surface of the inner leg, and push the outer leg up and down a few times.

Measure the correct amount of oil according to the specification card.

First, fill up the cartridge tube, then raise up the outer leg about 250 mm and add the remaining oil.

Notes

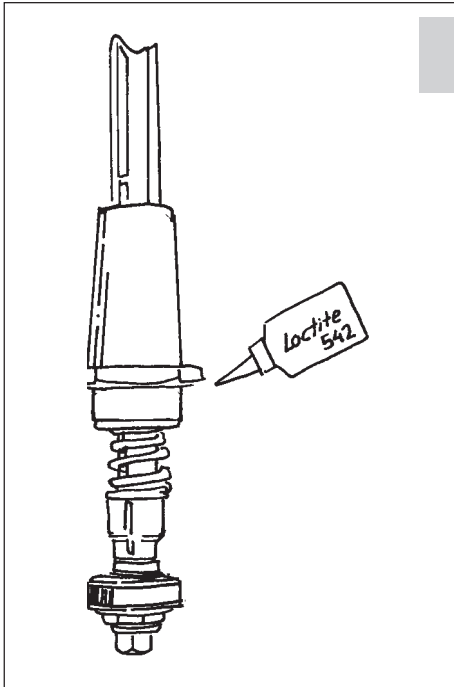

e

Install the damper rod assembly into the cartridge tube. Use Lotite 542 on the cartridge top lid.

Tighten with tool 1797-01. Tightening torque 65 Nm.

Pump the damper rod up and down a few times to check that there is no air left.

Pull out the damper rod as far as possible and close the compression- and the rebound valves.

Install the spring and the preload spacer.

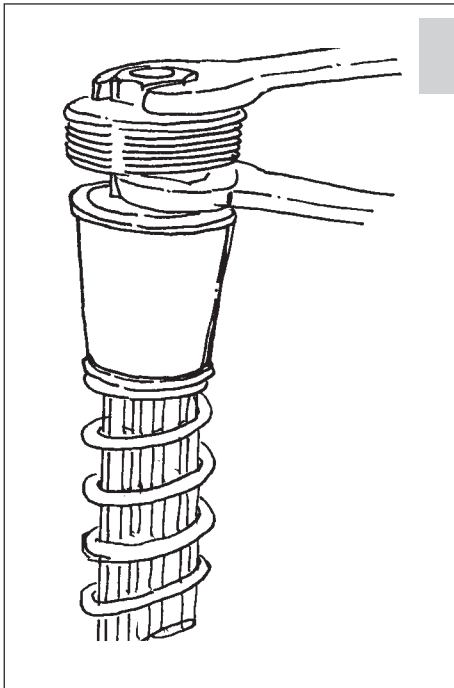

f

Install the fork top cap and the lock nut.

Tighten the top cap and the lock nut against each other, use a 16 and 24 mm wrench.

Fit the fork legs on the motorcycle.

For tightening torques, please see your bike's work shop manual.

Adjust the compression- and the rebound valves according to the specification card.

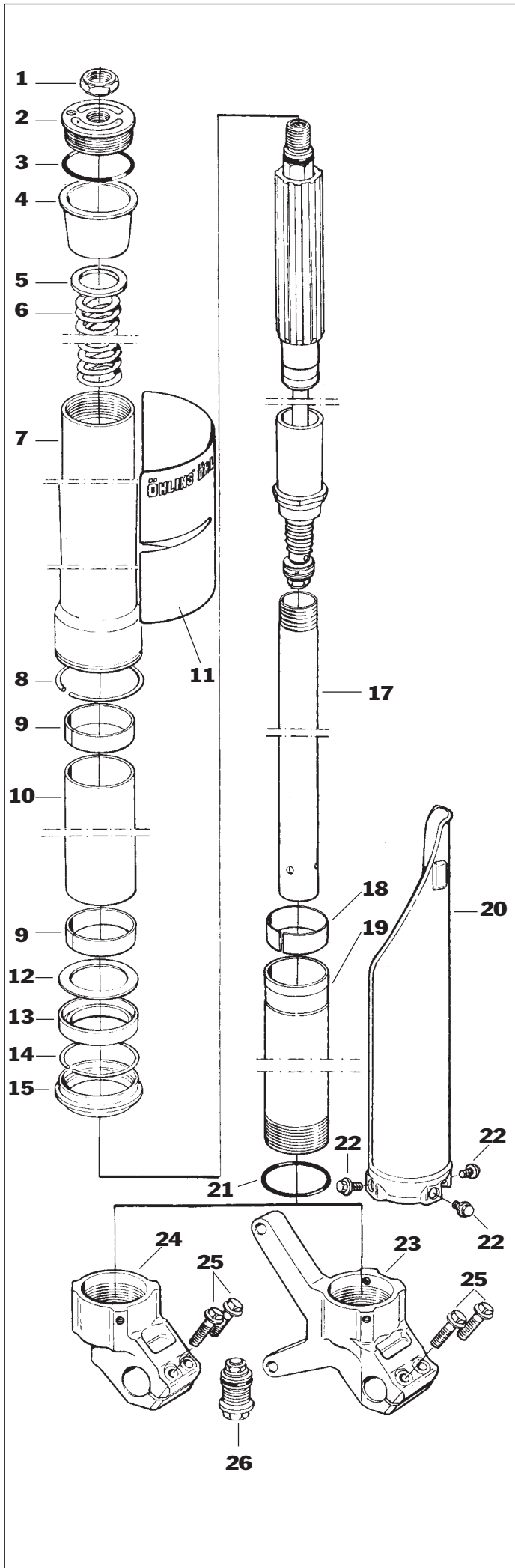

Spare parts

Pos.	Part No.	Pcs.	Description	Type/remarks
1	02338-01	2	Nut	
2	02306-02	2	Top cap	
3	00438-17	2	O-ring	
4	02337-01	2	Spring support	
5	02319-01		Preload washer	see spec. card
6	02328-39	2	Spring front fork	3,9 N/mm
	02328-41	2		4,1 N/mm
	02328-43	2		4,3 N/mm
	02328-45	2		4,5 N/mm
	02328-47	2		4,7 N/mm
7	02324-01	2	Fork leg outer	
8	00329-02	2	Circlip	
9	02021-01	4	Bushing lower	
10	02325-01	2	Sleeve	
11	02332-03	2	Cover Sticker Öhlins	
12	01552-01	2	Washer	
13	02336-01	2	Seal	
14	02015-01	2	Circlip	
15	02014-01	2	Scraper	
17	02339-01	2	Cylinder tube cartridge	
18	02022-01	2	Bushing upper	
19	02315-83	2	Fork leg inner	
20	02309-80	1	Cover fork leg pair	
21	00438-30	2	O-ring	
22	02314-01	6	Bolt	
23	02372-01	1	Fork bottom left	
24	02372-02	1	Fork bottom right	
25	02314-02	4	Bolt fork bottom	
-	00195-01	2	Sticker Öhlins white / transparent	

Spare parts

Pos.	Part No.	Pcs.	Description	Type/remarks
1	02338-01	2	Lock nut	
2	01050-01	2	Screw	
3	00338-59	2	O-ring	
4	02306-01	2	Top cap	
5	01473-02	2	Circlip	
6	00338-53	2	O-ring	
7	02321-02	1	Adjustment screw	
8	01248-01	2	Spring	
9	00884-04	4	Ball	
10	02366-12	2	Adjustment rod	
11	00338-76	2	O-ring	
12	02301-03	2	Needle housing	
13	02302-03	2	Guiding sleeve	
14	02303-01	2	Sleeve	
15	02304-01	2	Hydraulic stop	
16	00131-05	2	Circlip	
17	01499-02	2	Circlip	
18	02305-03	2	Cylinder tube cap	
19	02059-01	2	Bushing holder	
20	00338-19	2	O-ring	
21	00110-01	2	Bushing	
22	02340-01	2	Washer	
23	02307-01	2	Shaft	
24	02063-02	2	Spring	
25	00438-31	2	O-ring	
26	02356-03	2	Rebound needle	
27	02322-01	2	Spring	
28	02320-03	2	Piston holder	
29	00530-18	8	Shim washer	see spec. card, notes
30	01149-01	6	Wave washer	see spec. card, notes
31	-	-	Shims	see spec. card, notes
32	02335-01	2	Rebound piston	
33	01447-02	2	Piston ring	
34	-	-	Shim	see spec. card, rebound
36	-	2	Clamp washer	see spec. card, rebound
37	00153-01	2	Washer	
38	00430-05	2	Lock nut	
39	01473-02	2	Circlip	
40	00338-53	2	O-ring	
41	01242-05	2	Adjustment needle	
42	01248-01	2	Spring	
43	00884-04	4	Ball	
44	02054-02	2	End piece	
45	00438-02	2	O-ring	
46	-	2	Clamp washer	see spec. card compression
47	-	-	Shims	see spec. card compression
48	02334-01	2	Compression piston	
49	00438-03	2	O-ring	
50	00530-22	2	Shims	
51	01149-01	2	Wave washer	
52	00153-01	2	Washer	
53	00430-05	2	Nut	

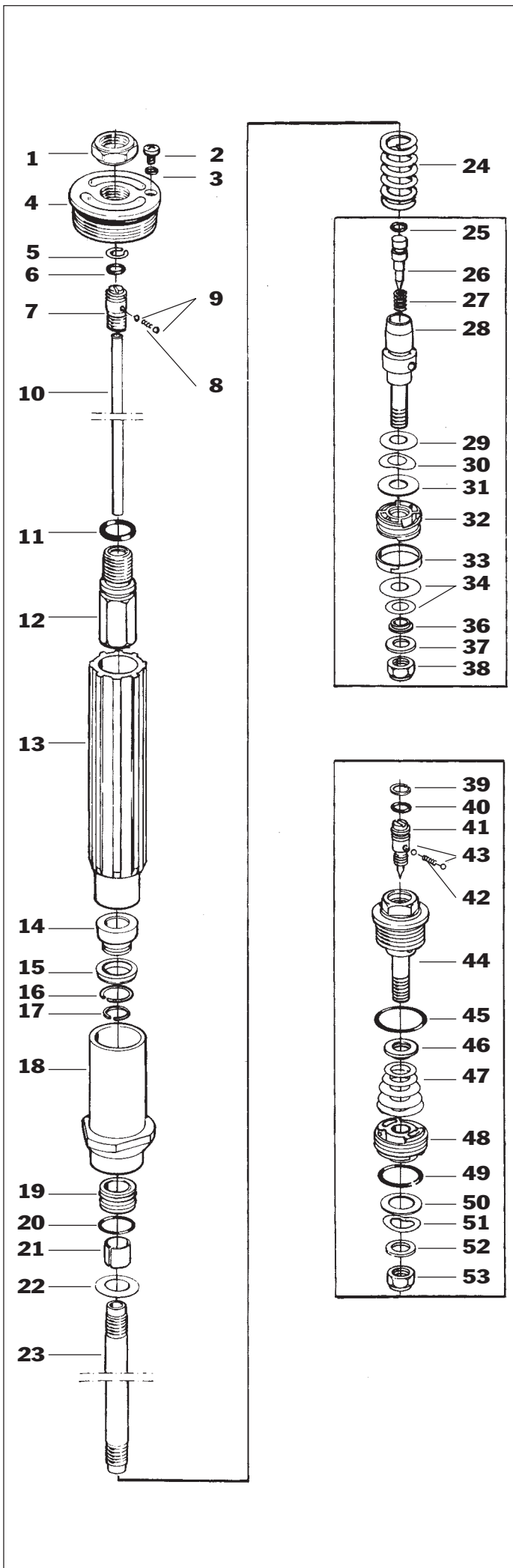

Öhlins distributors

Motorcycles

AUSTRALIA

Steve Cramer Proucts, BRAESIDE, Tel. +61 3 9587 1466, Fax. +61 3 9587 2018

AUSTRIA

Motopart Handelsges. m.b.H., WIEN, Tel. +43 1 667 6628, Fax. +43 1 667 0696

CANADA

S. Hansen Racing Products, EDMONTON, Tel. +1 403 466 8653, Fax. +1 403 465-9483

CROATIA

Moto ZIP trgovina d.o.o., KRANJ, Tel: +386 64 268 515, Fax: +386 64 268 514

DENMARK

F.I. Motorcykler ApS, SORÖ, Tel. +45 57 833 348, Fax. +45 57 834 855

ESTONIA

Ramo Ltd, VORU, Tel. +372 78 219 59, Fax. +372 78 219 59

FINLAND

Mauri Penttilä Racing, HYVINKÄÄ, Tel. +358 19 437 100, Fax. +358 19 489 872

FRANCE

P.F.P - Öhlins France, Arpajon-Sur-Cere, Tel. +33 471 481 534, Fax. +33 471 642 593

GERMANY

Zupin Moto-Sport GmbH, TRAUNREUT, Tel. +49 8669 8480, Fax. +49 8669 848590

GREECE

Vassilis Dulaveris, ATHENS, Tel. +30 1-923 6051, Fax. +30 1-924 9957

HONG KONG

Power Motorcycle Specialist, KOWLOON, Tel. +852 3903 949, Fax. +852 3919 434

ICELAND

Baldursson Trading, AKUREYRI, Tel: +354 8545 3136, Fax: +354 462 2777

ITALY

Motorquality S.p.A., SESTO S GIOVANNI (MI), Tel. +39 02 249 511, Fax. +39 02 2495 1232

JAPAN

Carrozzeria Japan Co., Ltd., SAITAMA-PREF; 336, Tel. +81 48 863 1801, Fax. +81 48 863 1802

The NETHERLANDS, BELGIUM, LUXEMBURG

Wim Kroon Import V.O.F., HV MILL, Tel. +31 485 453 911, Fax. +31 485 454 848

NORWAY

MC-Spesialisten, SKÅRER, Tel. +47 67 920 380, Fax. +47 67 972 855

NEW ZEALAND

Hawera Motorcycles LMVD, HAWERA TARNAKI, Tel.+64 627 84160, Fax. +64 627 86552

POLAND

P.T.M. SP. zo.o., NIEPORET, Tel. +48 22 774 8978, Fax. +48 22 774 8978

PORTUGAL

Motoni, AMADORA, Tel. +351 1 472 8160, Fax. +351 1 471 4809

RUSSIA

Alpine Ltd, MOSCOW 121 552, Tel. +7 95 149 5069, Fax. +7 95 141 2310

SINGAPORE

Sporting Motorcycles, SINGAPORE 1232, Tel. +65 250 5508, Fax. +65 253 6312

SLOVENIA

Moto ZIP trgovina d.o.o., KRANJ, Tel: +386 64 26 85 15, Fax: +386 64 26 85 14

SPAIN

Zacatin S.A., TORREJON DE ARDOZ, Tel. +34 91 677 7897, Fax. +34 91 677 6123

SWITZERLAND

3W Motorsport, WINTERTHUR, Tel. +41 52 315 3188, Fax. +41 52 315 3754

TAIWAN

Henly Company Ltd, TAIPEI 10422, Tel. +886 2 5375 600, Fax. +886 2 5631 357

TURKEY

Demaks Motor-Servis Hizmetleri A.S., ISTANBUL, Tel. +90 216 442 1580, Fax. +90 216 442 2380

U.K.

Harris Performance Prod. Ltd., HERTFORD, Tel. +44 1992 551 026, Fax. +44 1992 587 052

USA and CANADA

Parts Unlimited, JANESVILLE, WI 53547, Tel. +1 608 758 1111, Fax. +1 608 758 1144

service

Pettersson Pro Suspension, ANAHEIM, CA 92807, Tel. +1 714 630 4777, Fax. +1 714 630 4788

service

TUF Racing Products, DEKALB, IL 60115, Tel. +1 815 756 3588, Fax. +1 815 756 3528

(MX & Enduro steeringdampers)

Scotts Performance MC Products, MONTROSE, Tel. +1 818 248 6747, Fax. +1 818 248 4529

Öhlins Authorized Dealers in SWEDEN

Claessons Motor AB, Bromölla, Tel. 0456-230 30, Fax. 0456-232 31

R G Motor AB, Helsingborg, Tel. 042-16 96 60, Fax. 042-16 18 15

Nilssons Motor AB, Skåne-Fagerhult, Tel. 0433-300 70, Fax. 0433-300 80

DML Pro Bike, Värnamo, Tel. 0370-271 00, Fax 0370-271 61

LEJ Motor AB, Skövde, Tel. 0500-48 11 95, Fax. 0500-46 17 14

Carlarks Motor AB, Kumla, Tel. 019-57 07 01, Fax. 019-58 12 74

Beviks Motor AB, Linköping, Tel. 013-36 25 00, Fax. 013-36 25 10

BIKE Trollhättan AB, Trollhättan, Tel. 0520-700 75, Fax. 0520-762 84

Stötdämparexperten AB, Stockholm, Tel. 08-650 10 07, Fax. 08-650 10 09

Schneiders MC AB, Upplands Väsby, Tel. 08-590 310 80, Fax. 08-590 725 53

MB Racing AB, Västerås, Tel. 021-81 17 77, Fax. 021-81 17 78

Revelj Racing, Hede, Tel. 0684-120 59, Fax. 0684-122 75

Two Wheels I Umeå AB, Umeå, Tel. 090-187 595, Fax 090-18 77 61

Heds Motor AB, Boden, Tel. 0921-175 10, Fax. 0921-162 20



ADVANCED SUSPENSION TECHNOLOGY

Öhlins Racing AB, Box 722, S-194 27 Upplands Väsby, Sweden.

E-mail: info@ohlins.se

Web: www.ohlins.com