Hisense

SPLIT TYPE AIR CONDITIONER

SERVICE MANUAL

AS-09UR4SGNPQ

Hisense Corporation

Table of contents

	Page
1. OPERATING RANGE	1
2. SPECIFICATION.....	2
2-1 Unit specifications	
2-2 Major component specifications	
2-3 Other component specifications	
3. OUTLINES AND DIMENSIONS.....	6
3-1 INDOOR	
3-2 OUTDOOR	
4. REFRIGERANT FLOW DIAGRAM	8
4-1 Refrigerant flow diagram	
4-2 Evacuation procedures	
4-3 Evacuation direction	
5. ELECTRICAL DATA	11
5-1 Electric wiring diagrams	
5-2 Electric control	
5-3 Sensor parameter	
6. CONTROL MODE 16 6-1 control mode	18
7. TROUBLESHOOTING.....	26
7-1 Error codes	
7-2 Service flow chart	
8. CHECKING COMPONENTS.....	32
8-1 Check refrigerant system	
8-2 Check parts unit	
9. DISASSEMBLY INSTRUCTIONS	38
9-1 Indoor	
9-2 Outdoor	
10. PARTS LIST	45
10-1 Indoor	
10-2 Outdoor	

2-3-5. OVERLOAD PROTECTION

ELECTRIC PERFORMANCE	PARAMETER
Model	INT01L-4639/CS-74
Reset temperature(°C)	90±5°C
Trip temperature(°C)	120±4°C

2. SPECIFICATIONS**AS-09UR4SGNPQ****2-1. Unit specifications**

Model			AS-09UR4SGNPQ		
Function			Cooling	Heating	
Power supply			a.c 220V~230V/50Hz		
Capacity	Capacity	BTU	9000	12000	
		kW	2.6	3.2	
	Dehumidification	l/h	1.0	---	
	Air flow	m ³ /h	480	530	
Electrical data	Rated current	A	3.6	4.5	
	MAX. current	A	8.0	10.0	
	Rated input	kW	0.76	0.88	
	MAX. input	kW	1.50	1.85	
EER/COP			3.42	3.64	
MAX.operating pressure	High	MP	4.15		
Net size	Indoor unit	L×W×H	cm	75×19×25	
	Outdoor unit	L×W×H	cm	80×26×57	
Package size	Indoor unit	L×W×H	cm	84×27×31	
	Outdoor unit	L×W×H	cm	95×37×65	
Net weight	Indoor unit / Outdoor unit		kg	9.5/34.0	
Gross weight	Indoor unit / Outdoor unit		kg	11.5/38.5	
Refrigerant piping	Liquid pipe		mm	6.35	
	Gas pipe		mm	9.52	
	Connection method			Flared	
Special remarks	Sound level (Hi)	Indoor unit	dB	40	
		Outdoor unit	dB	52	
	Fan speed (Hi)	Indoor unit	rpm	800/1000/1250	
		Outdoor unit	rpm	540/620/800	
	Fan speed regulator	Indoor unit		3	
		Outdoor unit		1	
	Refrigerant filling capacity(R410A)		kg	0.72	
Throttle mode			CAPILLARY		

NOTE :Test conditions:

Cooling : Indoor: DB27℃/ WB19℃ Outdoor: DB35℃/ WB24℃

Heating: Indoor: DB20℃/ WB15℃ Outdoor: DB7℃/ WB 6℃

2-2. Major component specifications

2-2-1. INDOOR FAN MOTOR

ELECTRIC PERFORMANCE	PARAMETER
Motor model	YYW16-4-532
Rated power source	220V 50Hz
Phases/Poles	1/4
Rated load output(W)	16
Rated speed(r/min)	--
Ambient temperature(°C)	-5°C~+43°C.

2-2-2 OUTDOOR FAN MOTOR

ELECTRIC PERFORMANCE	PARAMETER
Motor model	YDK29-6I
Rated power source	220V 50Hz
Phases /Poles	1/6
Rated load output(W)	40
Ambient temperature(°C)	-5°C~+43°C.

2-2-3. COMPRESSOR

ELECTRIC PERFORMANCE	PARAMETER	
Compressor model	C-1RVN68HOE	
Compressor type	Rotary	
Rated power	675W	
Current (A)	4.75	
Motor	Motor type	DC brushless motor
	Starting type	DC Inverter
	Winding resistance	0.71 Ω (at 20°C)
Number of cylinder	1	
Oil type	FV50BX	
Oil charge (cc)	350	
Ambient temperature(°C)	-5°C~+43°C.	

2-3. Other component specifications

2-3-1. INDUCTANCE

ELECTRIC PERFORMANCE		PARAMETER
Inductance model		-
Rated power source		-
Rated current(A)	Loop winding rated current	-
	Filter winding rated current	-
Rated inductance(mH)	Loop winding rated inductance	-
	Filter winding rated inductance	-
Ambient temperature(°C)		-

2-3-2. INDUCTANCE(1205797,C)

ELECTRIC PERFORMANCE	PARAMETER
Inductance model	R2050HSB
Rated power source	220V 50Hz
Rated current(A)	20
Rated inductance(mH)	5.2
Ambient temperature(°C)	-20°C~+70°C.

2-3-3. FILTER(1336846,A)

ELECTRIC PERFORMANCE	PARAMETER
Filter model	RTLБ-12T047-02JF
Rated current(A)	12
Rated power source	AC 220V 50Hz
Filter frequency range	150K—30MHHz
Temperature range(°C)	-25°C~+85°C.

2-3-4. STEPPER MOTOR

ELECTRIC PERFORMANCE	PARAMETER
Stepper Motor model	24BYJ48-CP
Voltage(DC)	12V
Number of phase	4
Drive mode	1-2phase excitation unipolar drive
Resistance per phase	300 Ω ±7%
Temperature range(°C)	-10°C~+40°C.

2-3-5. OVERLOAD PROTECTION

ELECTRIC PERFORMANCE	PARAMETER
Model	INT01L-4639/CS-74
Reset temperature(°C)	90±5°C
Trip temperature(°C)	120±4°C

3-1. INDOOR

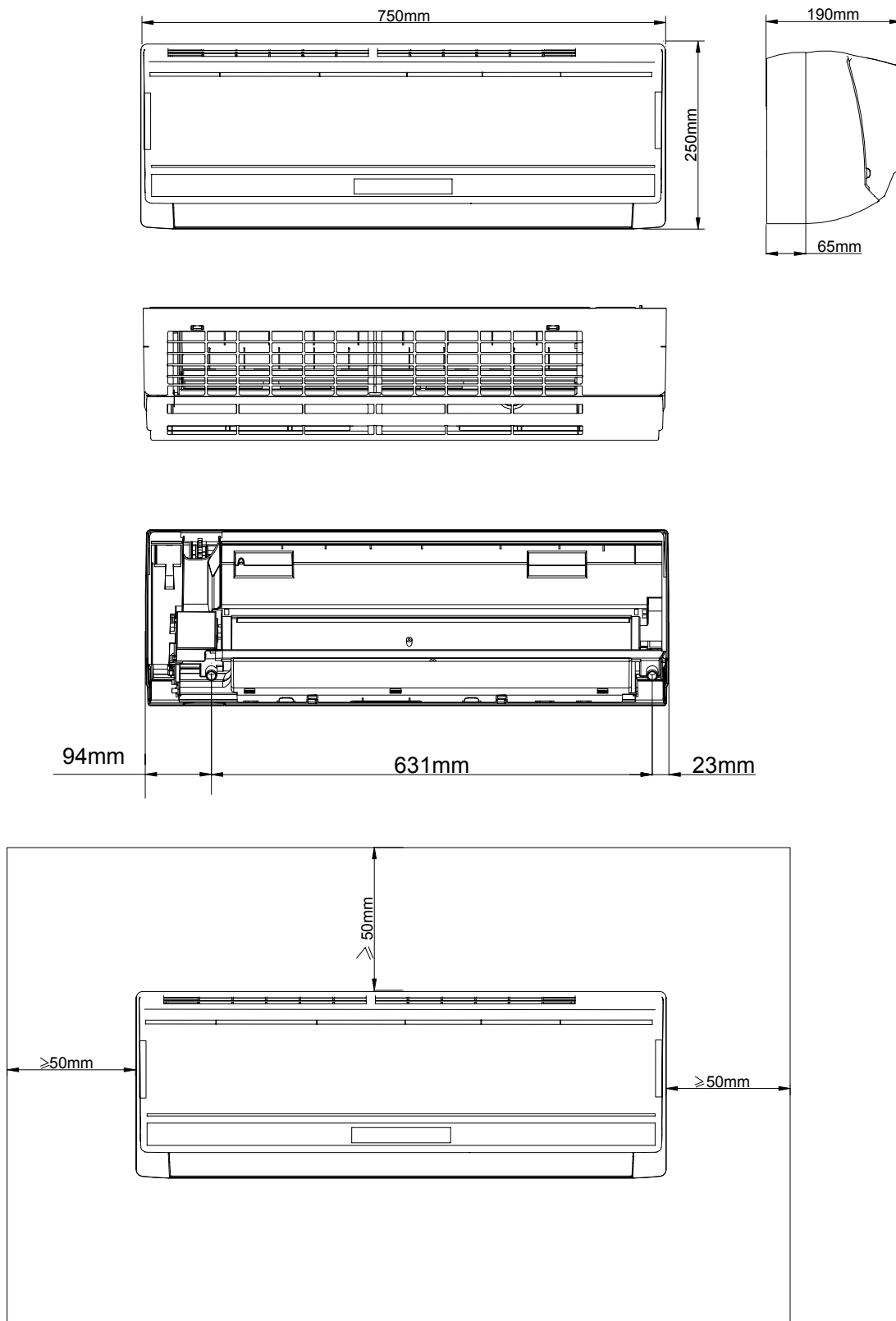

3-2. OUTDOOR

3. OUTLINES AND DIMENSIO

AS-09UR4SGNPQ

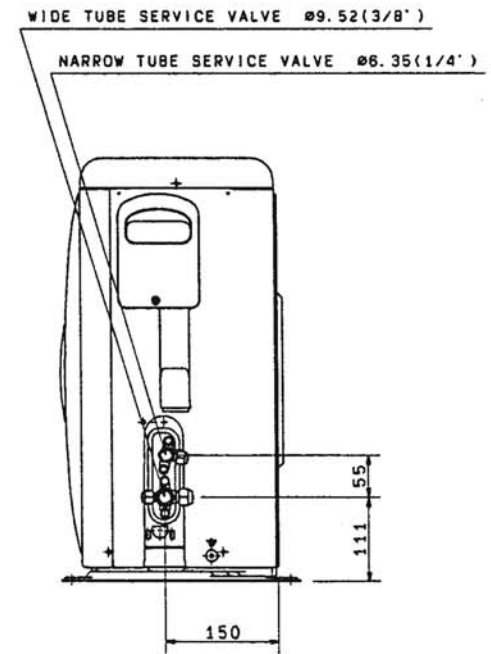
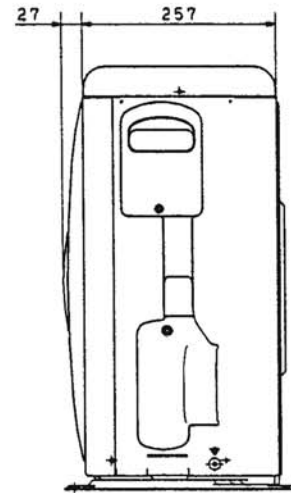
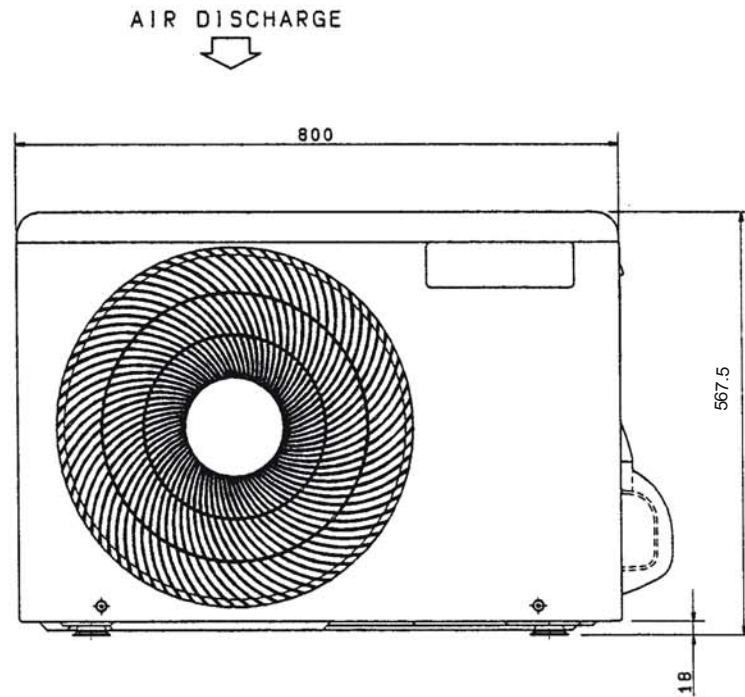
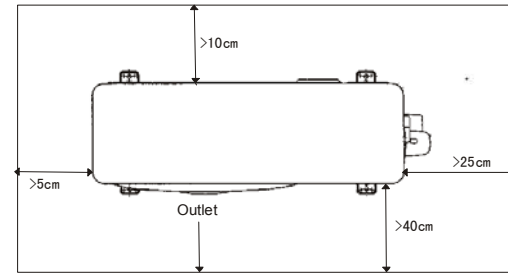
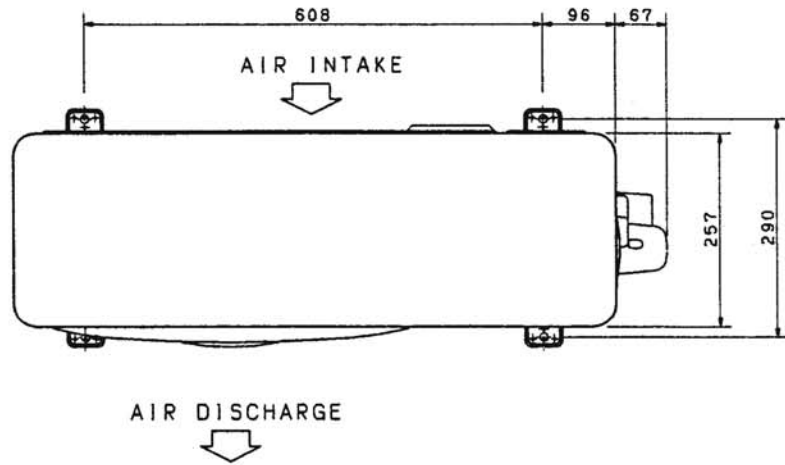

4-1. Refrigerant flow diagram :

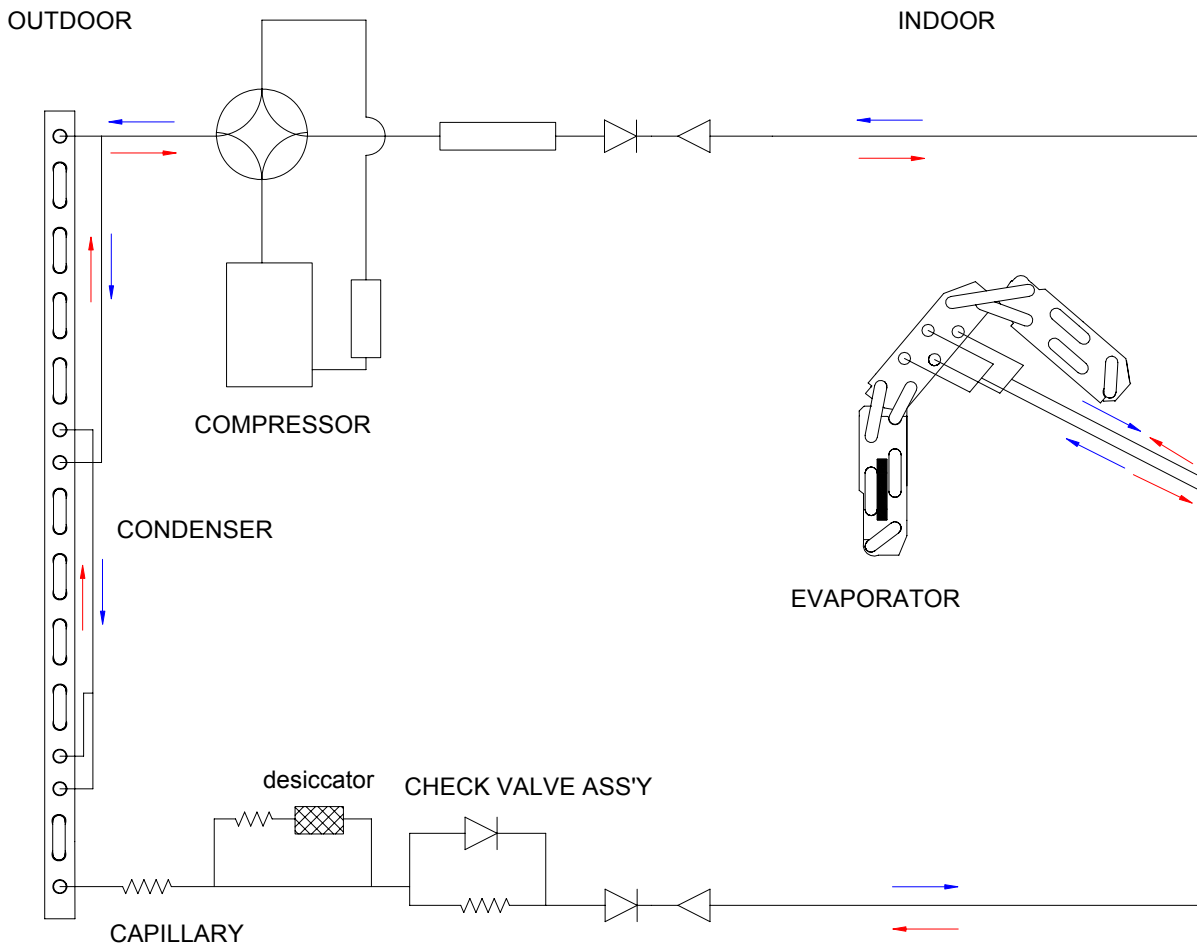

Remark:  **COOLING CYCLE**

Remark:  **HEATING CYCLE**

4-2. Evacuation procedures:

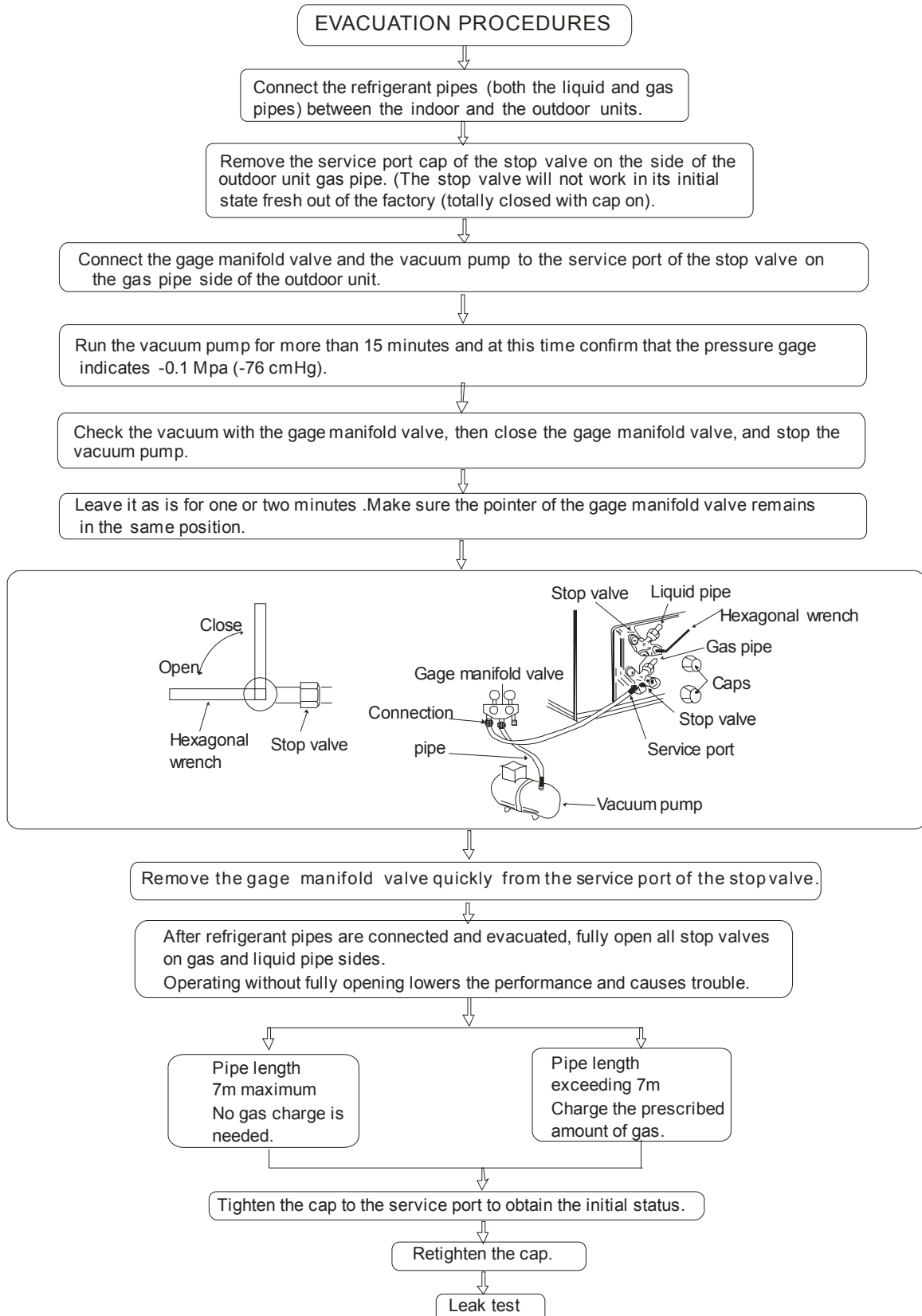

4-3. Evacuation direction:

MAX. REFRIGERANT PIPING LENGTH

Models	Refrigerant Piping Max. Length: m A	Piping size (OD) : mm		Length of connecting pipe : m	
		Gas	Liquid	Indoor unit	Outdoor unit
AS-09UR4SGNZA	15	9.52	6.35		

MAX. HEIGHT DIFFERENCE

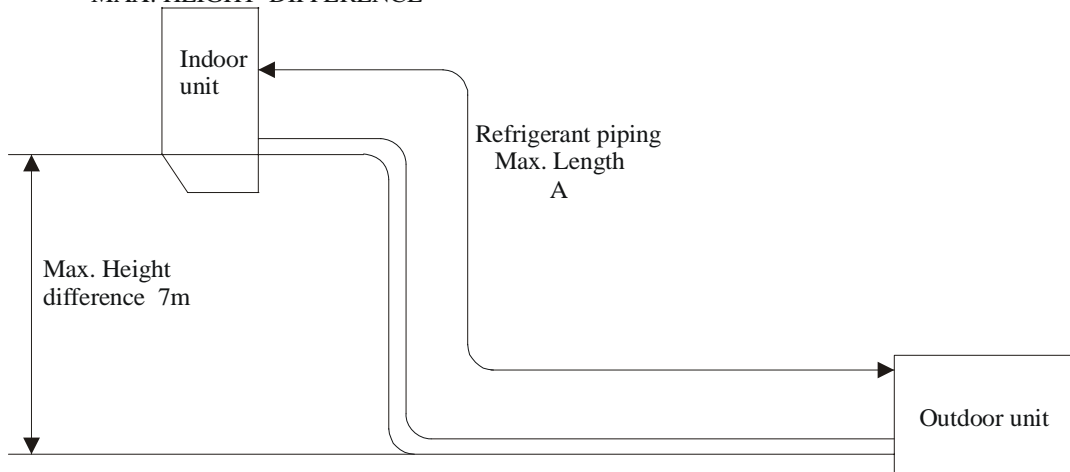

ADDITIONAL: REFRIGERANT CHARGE(R-410A: g)

Models	Outdoor unit precharged (up to 7m)	Refrigerant piping length		
		7m	10m	15m
AS-09UR4SGNZA	670	0	45	120

Calculation : $Xg=15g/m*(A-7)m$

5. ELECTRICAL DATA

AS-09UR4SGNPQ

5-1. Electrical wiring diagrams

1. INDOOR

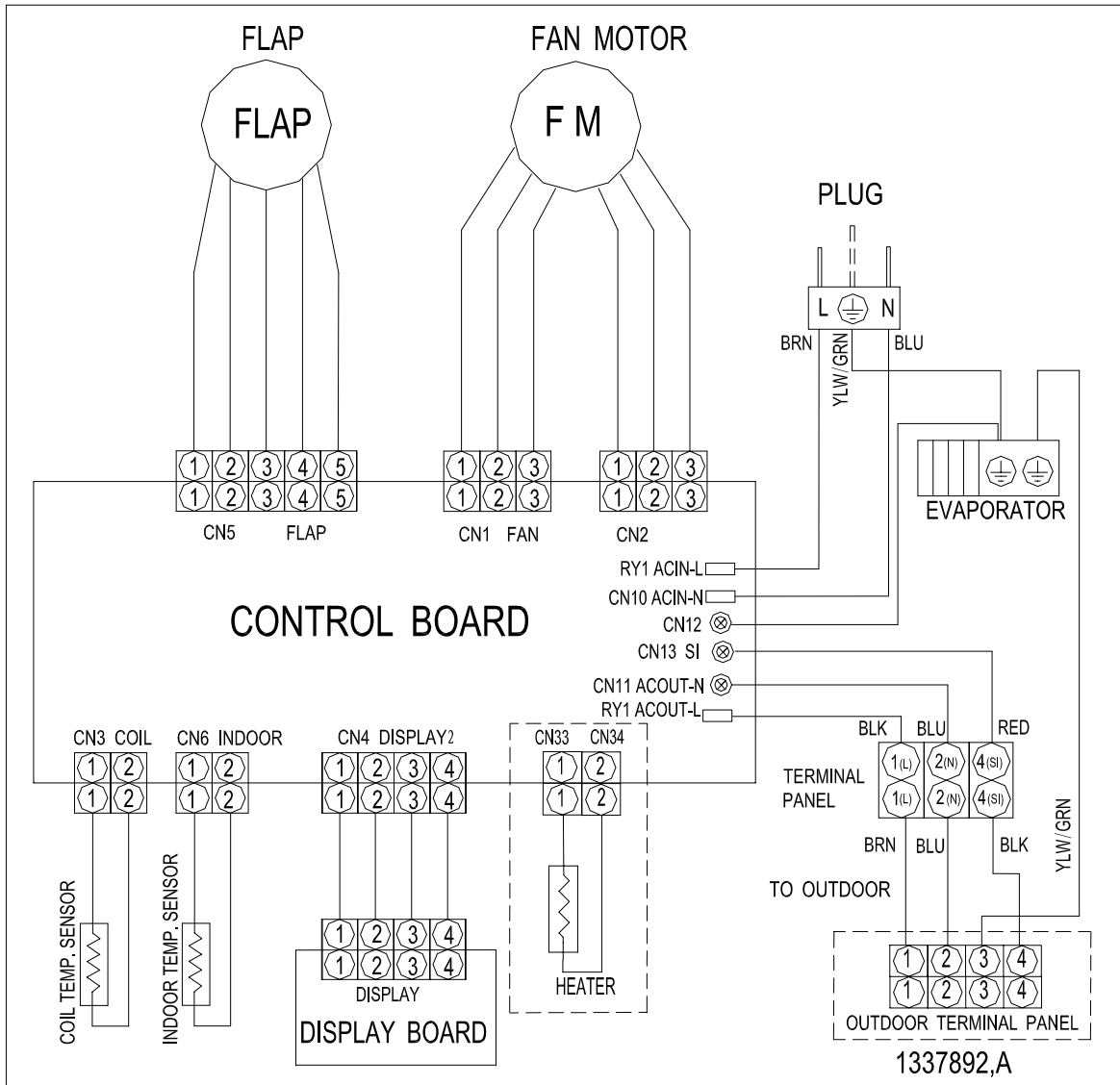

2. OUTDOOR

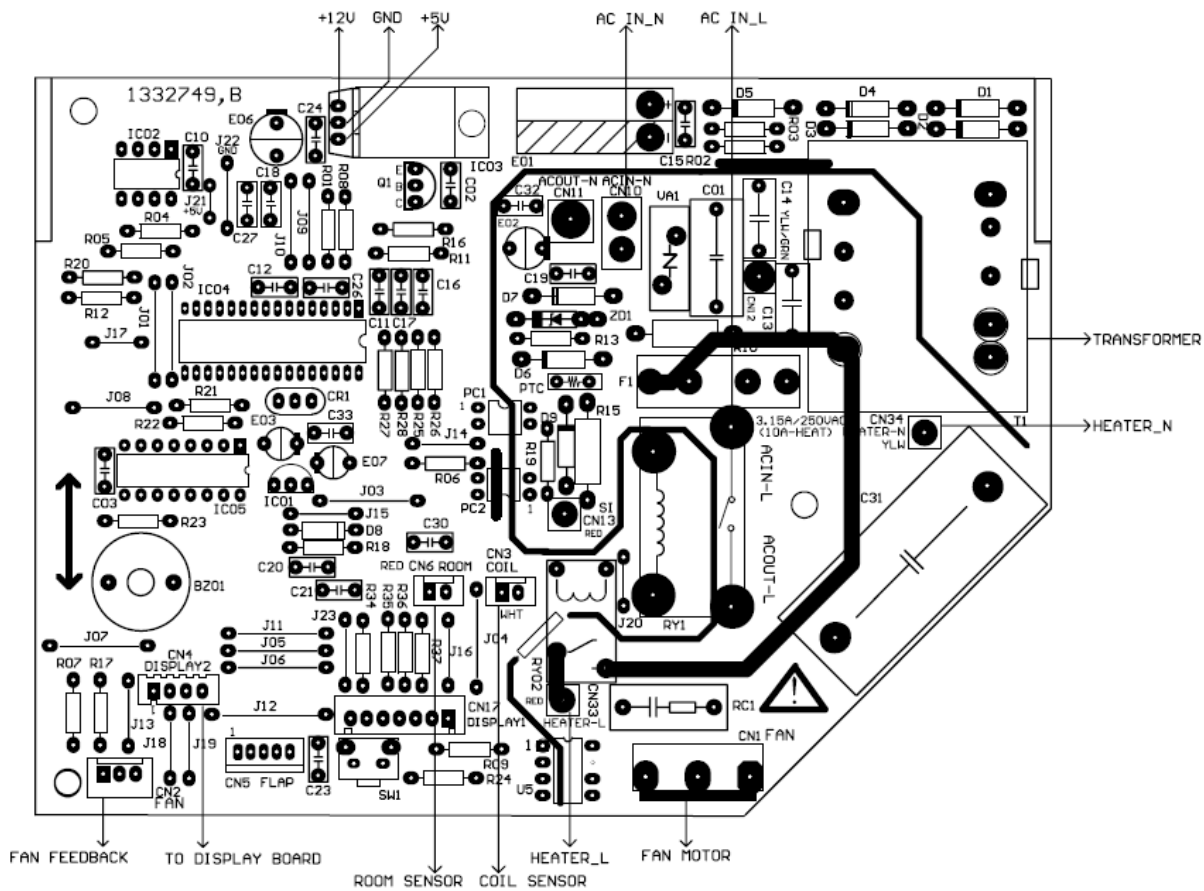

2. Outdoor control

5. ELECTRICAL DATA

AS-09UR4SGNPQ

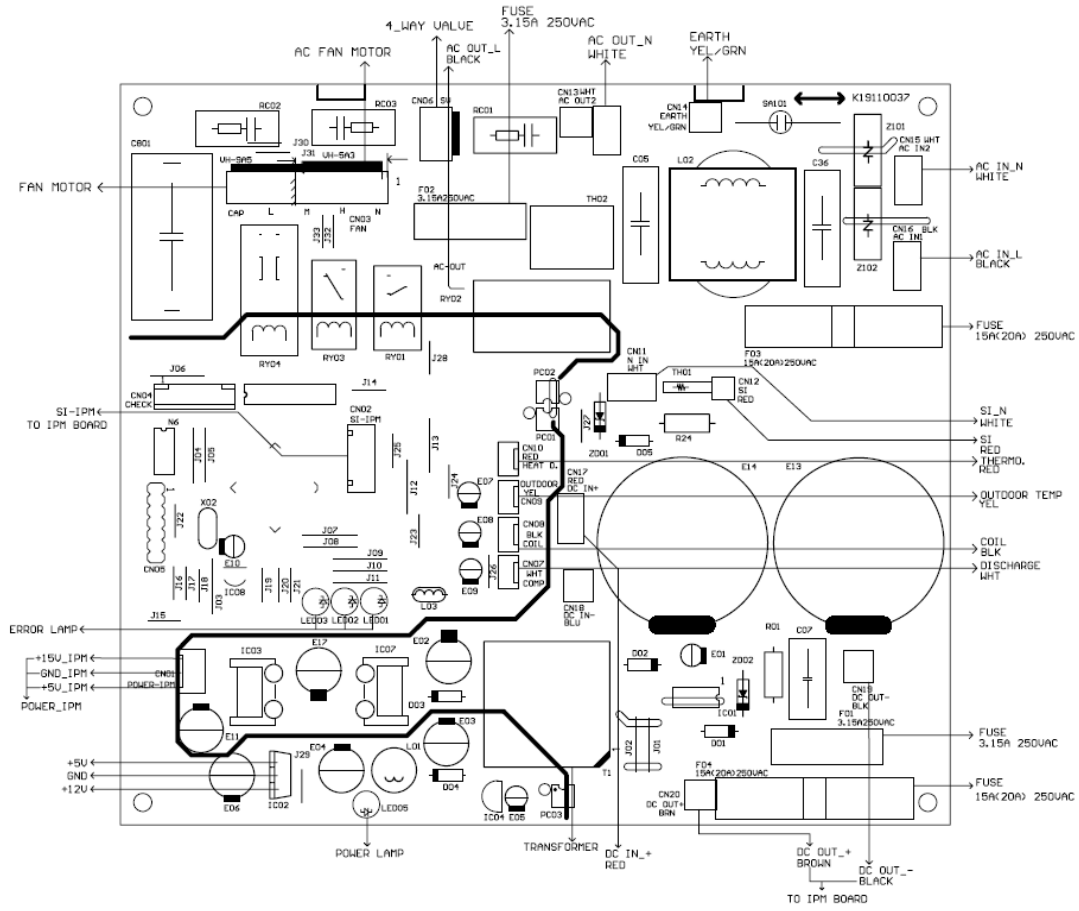

5. ELECTRICAL DATA

AS-09UR4SGNPQ

OUT IPM:

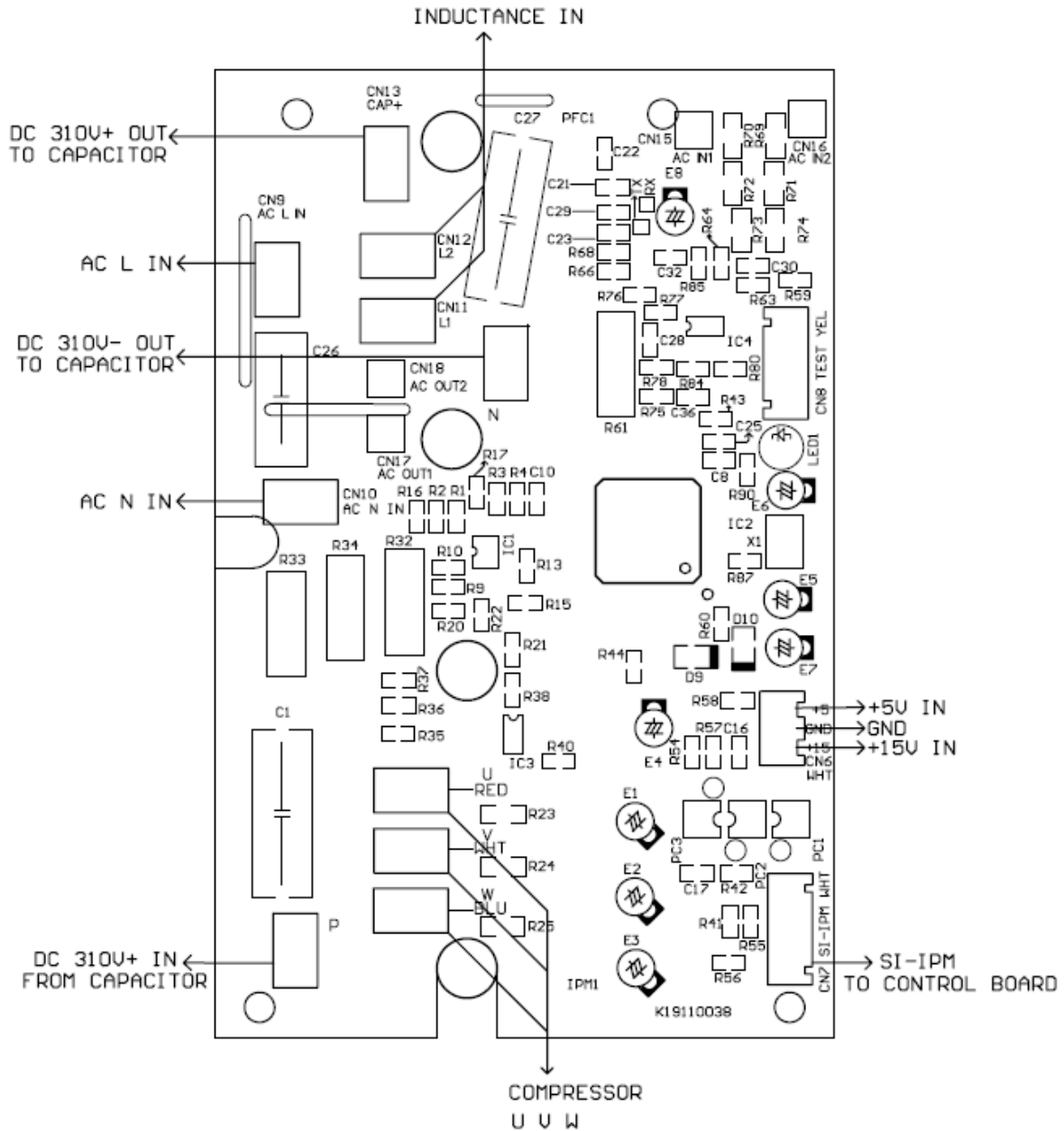

5. ELECTRICAL DATA

AS-09UR4SGNPQ

1. THE PARAMETER OF OUTDOOR COMPRESSOR TEMPERATURE SENSOR:

($R_0=187.25K\pm 6.3\%$; $R_{100}=3.77K\pm 2.5K$; $B=3979\pm 1\%$)

T(°C)	R(KΩ)	V(μ)	DEC	HEX	T(°C)	R(KΩ)	V(μ)	DEC	HEX	T(°C)	R(KΩ)	V(μ)	DEC	HEX
-30	966.1	0.1014	5	5	26	55.46	1.3252	68	44	82	6.662	3.7507	191	BF
-29	910.3	0.1075	5	5	27	53.11	1.3678	70	46	83	6.446	3.7813	193	C1
-28	858	0.1139	6	6	28	50.86	1.4112	72	48	84	6.239	3.8111	194	C2
-27	809	0.1206	6	6	29	48.72	1.4552	74	4A	85	6.039	3.8404	196	C4
-26	763.1	0.1277	7	7	30	46.68	1.4997	76	4C	86	5.846	3.8691	197	C5
-25	720	0.1351	7	7	31	44.74	1.5446	79	4F	87	5.661	3.8970	199	C7
-24	679.6	0.1429	7	7	32	42.89	1.5901	81	51	88	5.482	3.9243	200	C8
-23	641.7	0.1511	8	8	33	41.13	1.6359	83	53	89	5.309	3.9512	202	CA
-22	606.1	0.1597	8	8	34	39.44	1.6824	86	56	90	5.143	3.9773	203	CB
-21	572.7	0.1687	9	9	35	37.84	1.7289	88	58	91	4.982	4.0029	204	CC
-20	541.3	0.1782	9	9	36	36.3	1.7762	91	5B	92	4.827	4.0279	205	CD
-19	511.7	0.1881	10	A	37	34.84	1.8235	93	5E	93	4.678	4.0522	207	CF
-18	484	0.1984	10	A	38	33.44	1.8713	95	5F	94	4.534	4.0760	208	D0
-17	457.9	0.2092	11	B	39	32.11	1.9190	98	62	95	4.395	4.0992	209	D1
-16	433.3	0.2206	11	B	40	30.83	1.9673	100	64	96	4.261	4.1218	210	D2
-15	410.2	0.2325	12	C	41	29.61	2.0157	103	67	97	4.132	4.1439	211	D3
-14	388.5	0.2448	12	C	42	28.45	2.0640	105	69	98	4.007	4.1655	212	D4
-13	368	0.2577	13	D	43	27.34	2.1124	108	6C	99	3.886	4.1866	214	D6
-12	348.7	0.2712	14	E	44	26.27	2.1612	110	6E	100	3.77	4.2070	215	D7
-11	330.5	0.2853	15	F	45	25.25	2.2099	113	71	101	3.658	4.2269	216	D8
-10	313.4	0.2999	15	F	46	24.28	2.2584	115	73	102	3.549	4.2465	217	D9
-9	297.2	0.3153	16	10	47	23.35	2.3068	118	76	103	3.444	4.2655	218	DA
-8	281.9	0.3312	17	11	48	22.46	2.3552	120	78	104	3.343	4.2839	218	DA
-7	267.5	0.3478	18	12	49	21.6	2.4038	123	7B	105	3.15	4.3197	220	DC
-6	253.9	0.3651	19	13	50	20.79	2.4516	125	7D	106	3.059	4.3367	221	DD
-5	241.1	0.3830	20	14	51	20.01	2.4994	127	7F	107	2.97	4.3535	222	DE
-4	229	0.4016	20	14	52	19.26	2.5471	130	82	108	2.884	4.3699	223	DF
-3	217.6	0.4209	21	15	53	18.54	2.5947	132	84	109	2.802	4.3856	224	E0
-2	206.8	0.4409	22	16	54	17.85	2.6420	135	87	110	2.721	4.4012	224	E0
-1	196.6	0.4617	24	17	55	17.19	2.6889	137	89	111	2.721	4.4012	224	E0
0	186.9	0.4833	25	18	56	16.56	2.7352	139	8B	112	2.644	4.4162	225	E1
1	177.8	0.5056	26	19	57	15.96	2.7809	142	8E	113	2.569	4.4309	226	E2
2	169.2	0.5285	27	1A	58	15.38	2.8265	144	90	114	2.496	4.4452	227	E3
3	161	0.5525	28	1B	59	14.82	2.8719	146	92	115	2.426	4.4591	227	E3
4	153.3	0.5770	29	1C	60	14.29	2.9163	149	95	116	2.358	4.4727	228	E4
5	146	0.6024	31	1E	61	13.78	2.9603	151	97	117	2.292	4.4859	229	E5
6	139	0.6289	32	1F	62	13.28	3.0048	153	99	118	2.228	4.4988	229	E5
7	132.5	0.6557	33	21	63	12.81	3.0479	155	9B	119	2.167	4.5112	230	E6
8	126.3	0.6835	35	23	64	12.36	3.0902	158	9E	120	2.107	4.5235	231	E7
9	120.4	0.7123	36	24	65	11.93	3.1319	160	A0	121	2.049	4.5354	231	E7
10	114.8	0.7418	38	26	66	11.51	3.1736	162	A2	122	2.049	4.5354	231	E7
11	109.5	0.7722	39	27	67	11.11	3.2144	164	A4	123	1.994	4.5467	232	E8
12	104.4	0.8039	41	29	68	10.73	3.2541	166	A6	124	1.887	4.5689	233	E9
13	99.66	0.8357	43	2B	69	10.36	3.2938	168	A8	125	1.836	4.5796	234	EA
14	95.13	0.8686	44	2D	70	10	3.3333	170	AA	126	1.787	4.5899	234	EA
15	90.82	0.9024	46	2C	71	9.659	3.3717	172	AC	127	1.739	4.6000	235	EB
16	86.74	0.9369	48	2E	72	9.331	3.4094	174	AE	128	1.693	4.6098	235	EB
17	82.85	0.9723	50	32	73	9.016	3.4464	176	B0	129	1.649	4.6192	236	EC
18	79.16	1.0085	51	33	74	8.712	3.4829	178	B2	130	1.605	4.6286	236	EC
19	75.65	1.0455	53	35	75	8.421	3.5185	179	B3					
20	72.32	1.0832	55	37	76	8.14	3.5537	181	B5					
21	69.15	1.1217	57	39	77	7.869	3.5882	183	B7					
22	66.13	1.1610	59	3B	78	7.609	3.6220	185	B9					
23	63.27	1.2009	61	3D	79	7.359	3.6551	186	BA					
24	60.54	1.2416	63	3F	80	7.118	3.6876	188	BC					
25	57.94	1.2830	65	41	81	6.885	3.7195	190	BE					

5. ELECTRICAL DATA

AS-09UR4SGNPQ

2. THE PARAMETER OF THE COIL AND INDOOR AND OUTDOOR SENSOR: ($R_0=15K\pm 2\%$;
 $B=3450\pm 2\%$)

T(°C)	R(KΩ)	V(v)	DEC	HEX	T(°C)	R(KΩ)	V(v)	DEC	HEX	T(°C)	R(KΩ)	V(v)	DEC	HEX
-30	67.94	0.3235	16	10	18	6.962	2.0151	103	67	66	1.297	3.9186	200	C8
-29	64.25	0.3408	17	11	19	6.688	2.0636	105	69	67	1.258	3.9443	201	C9
-28	60.79	0.3588	18	12	20	6.427	2.1120	108	6C	68	1.22	3.9696	202	CA
-27	57.53	0.3776	19	13	21	6.178	2.1603	110	6E	69	1.184	3.9939	204	CC
-26	54.48	0.3971	20	14	22	5.939	2.2089	113	71	70	1.149	4.0178	205	CD
-25	51.6	0.4174	21	15	23	5.712	2.2570	115	73	71	1.116	4.0406	206	CE
-24	48.9	0.4384	22	16	24	5.494	2.3053	118	76	72	1.083	4.0636	207	CF
-23	46.35	0.4603	23	17	25	5.286	2.3533	120	78	73	1.051	4.0862	208	D0
-22	43.96	0.4829	25	19	26	5.086	2.4014	122	7A	74	1.021	4.1077	209	D1
-21	41.7	0.5065	26	1A	27	4.896	2.4489	125	7D	75	0.9914	4.1290	211	D3
-20	39.58	0.5307	27	1B	28	4.714	2.4963	127	7F	76	0.963	4.1497	212	D4
-19	37.58	0.5558	28	1C	29	4.539	2.5436	130	82	77	0.9354	4.1701	213	D5
-18	35.69	0.5818	30	1E	30	4.372	2.5904	132	84	78	0.9088	4.1898	214	D6
-17	33.91	0.6087	31	1F	31	4.212	2.6369	134	86	79	0.8831	4.2091	215	D7
-16	32.23	0.6363	32	20	32	4.059	2.6830	137	89	80	0.8582	4.2280	216	D8
-15	30.65	0.6648	34	22	33	3.912	2.7288	139	8B	81	0.8342	4.2463	217	D9
-14	29.15	0.6942	35	23	34	3.772	2.7738	141	8D	82	0.8109	4.2643	217	D9
-13	27.74	0.7244	37	25	35	3.637	2.8188	144	90	83	0.7884	4.2818	218	DA
-12	26.4	0.7556	39	27	36	3.508	2.8631	146	92	84	0.7666	4.2988	219	DB
-11	25.14	0.7875	40	28	37	3.384	2.9070	148	94	85	0.7455	4.3155	220	DC
-10	23.95	0.8202	42	2A	38	3.265	2.9504	150	96	86	0.725	4.3318	221	DD
-9	22.82	0.8539	44	2C	39	3.151	2.9932	153	99	87	0.7053	4.3476	222	DE
-8	21.75	0.8885	45	2D	40	3.041	3.0358	155	9B	88	0.6861	4.3631	223	DF
-7	20.74	0.9237	47	2F	41	2.936	3.0775	157	9D	89	0.6676	4.3781	223	DF
-6	19.79	0.9596	49	31	42	2.835	3.1188	159	9F	90	0.6496	4.3929	224	E0
-5	18.88	0.9966	51	33	43	2.739	3.1590	161	A1	91	0.6323	4.4071	225	E1
-4	18.02	1.0343	53	35	44	2.646	3.1990	163	A3	92	0.6156	4.4209	225	E1
-3	17.2	1.0731	55	37	45	2.556	3.2387	165	A5	93	0.5993	4.4345	226	E2
-2	16.43	1.1122	57	39	46	2.471	3.2771	167	A7	94	0.5836	4.4477	227	E3
-1	15.7	1.1520	59	3B	47	2.388	3.3155	169	A9	95	0.5683	4.4606	227	E3
0	15	1.1929	61	3D	48	2.309	3.3528	171	AB	96	0.5535	4.4732	228	E4
1	14.34	1.2342	63	3F	49	2.233	3.3896	173	AD	97	0.5391	4.4855	229	E5
2	13.71	1.2765	65	41	50	2.159	3.4262	175	AF	98	0.5251	4.4975	229	E5
3	13.11	1.3195	67	43	51	2.089	3.4615	177	B1	99	0.5115	4.5093	230	E6
4	12.55	1.3623	69	45	52	2.021	3.4965	178	B2	100	0.4983	4.5207	231	E7
5	12.01	1.4063	72	48	53	1.956	3.5306	180	B4	101	0.4855	4.5319	231	E7
6	11.5	1.4506	74	4A	54	1.893	3.5644	182	B6	102	0.4731	4.5427	232	E8
7	11.01	1.4959	76	4C	55	1.832	3.5977	183	B7	103	0.461	4.5534	232	E8
8	10.55	1.5410	79	4F	56	1.774	3.6299	185	B9	104	0.4492	4.5638	233	E9
9	10.1	1.5878	81	51	57	1.718	3.6616	187	BB	105	0.4378	4.5739	233	E9
10	9.684	1.6338	83	53	58	1.664	3.6926	188	BC	106	0.4268	4.5838	234	EA
11	9.284	1.6805	86	56	59	1.612	3.7231	190	BE	107	0.416	4.5934	234	EA
12	8.903	1.7276	88	58	60	1.562	3.7528	191	BF	108	0.4055	4.6029	235	EB
13	8.54	1.7749	91	5B	61	1.513	3.7824	193	C1	109	0.3953	4.6121	235	EB
14	8.194	1.8226	93	5D	62	1.467	3.8106	194	C2	110	0.3854	4.6211	236	EC
15	7.864	1.8704	95	5F	63	1.422	3.8386	196	C4					
16	7.549	1.9185	98	62	64	1.379	3.8658	197	C5					
17	7.249	1.9667	100	64	65	1.337	3.8927	199	C7					

Control mode

1. Major general technical parameters

- 1 Conditionings for operation: Ambient temperatures: (-15 - +45 °C), relative humidity (45 - 85%).
- 2 Remote receiver distance: 8 m.
- 3 Remote receiver angle: Less than 80 degrees.
- 4 Temperature control accuracy: $\pm 1^{\circ}\text{C}$.
- 5 Time error: Less than 1%.
- 6 The power supply for the air conditioner is a.c 220V, 50Hz, with its fluctuation in the range of (160 – 253 V).

2. Functions of the controller

2.1 Display panel

I. Control functions of the remote controller (See operating and installation manual)

II. Display of the indoor unit

Information on the screen:

The picture of the display is as follows:



Displaying Scheme:

1. Timer: ON, OFF, Enabled (the "Clock" sign appears), Cancel
2. Sleep. Enabled (the "sleep" sign appears), Cancel (the "sleep" sign disappears)
3. High efficient. Enabled (the "H" sign appears), Cancel (the "H" sign disappears)
4. Temperature: the temperature value is displayed according to the data from the indoor CPU. "— —" is displayed when there is no temperature value.
5. Frequency: the frequency value is displayed according to the data from the indoor CPU:
6. Display of error codes:
An error code is displayed according to the signal from the indoor CPU. The error code will flash for 5 seconds while displayed.

3. Control function

3.1 Emergency switch

3.1.1 Press the emergency switch once to turn on the machine and press it again to turn off the machine; in the automatic mode, the indoor control temperature is set at 24°C with the indoor fan speed setting is automatic and the flaps sweep.

3.1.2 When the machine is turned on (in the OFF condition), press and hold the emergency switch for 5 seconds, the buzzer rings for 3 times and the controller starts in the trial operation. The trial operation is the forced cooling with the indoor fan speed being set at high speeds, the flaps sweeping and the air conditioner's

operation is irrelevant with room temperatures.

3.1.3 If a remote signal has been received during the emergency run, the machine will operate upon the command of such a remote signal.

3.2 Operator-machine communication

3.2.1 The air conditioner has a thermal sensor to detect room temperatures. Some remote controller is equipped with a thermal sensor (Such remote controller has the function of man-machine communication. For details, refer to the section for the remote controller). In addition, there is a thermal sensor at the indoor air inlet. In the case where the remote controller is equipped with a thermal sensor, the default setting for room temperatures is subject to the detection by the remote controller. The remote controller detects the room temperature once every 20 seconds, and automatically transmits a signal at an interval of 3 minutes or when a change in the room temperature is detected. If the indoor control unit has not received a remote signal for more than 10 minutes, the control function will be automatically switched over to the thermal sensor on the indoor unit.

3.2.2 Neither the turning on nor turning off operation will cancel the operator-machine communication function.

3.2.3 In default, the air conditioner is set to start the operator-machine communication function.

3.3 Timer function

3.3.1 Timer on: When set to start in a time by the remote controller, the air conditioner starts in the timer on condition. When the set time is up, the air conditioner will turn on and operates in the preset conditions after receiving a signal from the remote controller. If the air conditioner has not received a signal from the remote controller when the set time is up, it will automatically start and operate in the preset conditions.

3.3.2 Timer off: When set to stop in a set time by the remote controller, the air conditioner will start in the timer off condition. When the set time is up, the air conditioner will turn off after receiving a signal from the remote controller. If the air conditioner has not received a signal from the remote controller when the set time is up, it will turn off automatically.

3.3.3 Neither the turning on nor turning off operation will cancel the timer function (Some remote controller has a simple one-hour timer off function and excludes this operation).

3.4 Sleep

3.4.1 In the heating, cooling or dehumidifying mode, press the "Sleep" button on the remote controller to start or cancel the sleep function in turn, and at the same time the sleep icon on the display screen will be on or off accordingly.

3.4.2 According to the different needs, there are four different sleep modes to choose. During the time of sleep mode, the set temperature will change automatically.

3.4.3 In default, the setting is to cancel the sleep function. Turning off the unit will

also cancel the sleep function.

3.4.4 The sleep function is valid for 8 hours. The air conditioner will turn off and cancel the sleep function after the sleep function works for 8 hours.

3.5 High efficient run function

In the heating (except for the single cooling unit), cooling or dehumidifying mode, it may be set for high efficient run with the indoor fan speed changed to the high efficient fan speed and the compressor operating at the highest frequency as available. If the display screen can display the frequency, the frequency displayed on the screen is up to the maximum. It will restore to the previous run state after 15 minutes operation automatically.

3.6 Automatic run mode

If there is no man-machine communication function after the unit is started, the indoor fan operates at the ultra-low flowrate for 20 seconds before selecting a run mode; The room temperatures are detected during this period for the selection of a run mode.

In the first operation:

- a. When $T_{\text{room}} - T_{\text{set}} > 3^{\circ}\text{C}$, it starts in the cooling mode;
- b. When $-3^{\circ}\text{C} \leq T_{\text{room}} - T_{\text{set}} \leq 3^{\circ}\text{C}$, it starts in the ventilation run mode;
- c. When $T_{\text{room}} - T_{\text{set}} < -3^{\circ}\text{C}$, it starts in the heating mode.

After the first run in the cooling or heating mode, the mode will be changed as the following:

- a. When $T_{\text{room}} - T_{\text{set}} > 3^{\circ}\text{C}$, it will be changed to the cooling mode;
- b. When $T_{\text{room}} - T_{\text{set}} < -3^{\circ}\text{C}$, it will be changed to the heating mode;
- c. When these conditions are not met, it will remain in the previous run mode.

When the temperature setting is changed, re-judgment will be made for the run mode according to the descriptions mentioned above; when the compressor is halted for 10 minutes, the re-judgment will be made for the run mode.

3.6.1 Switch between the cooling and heating mode:

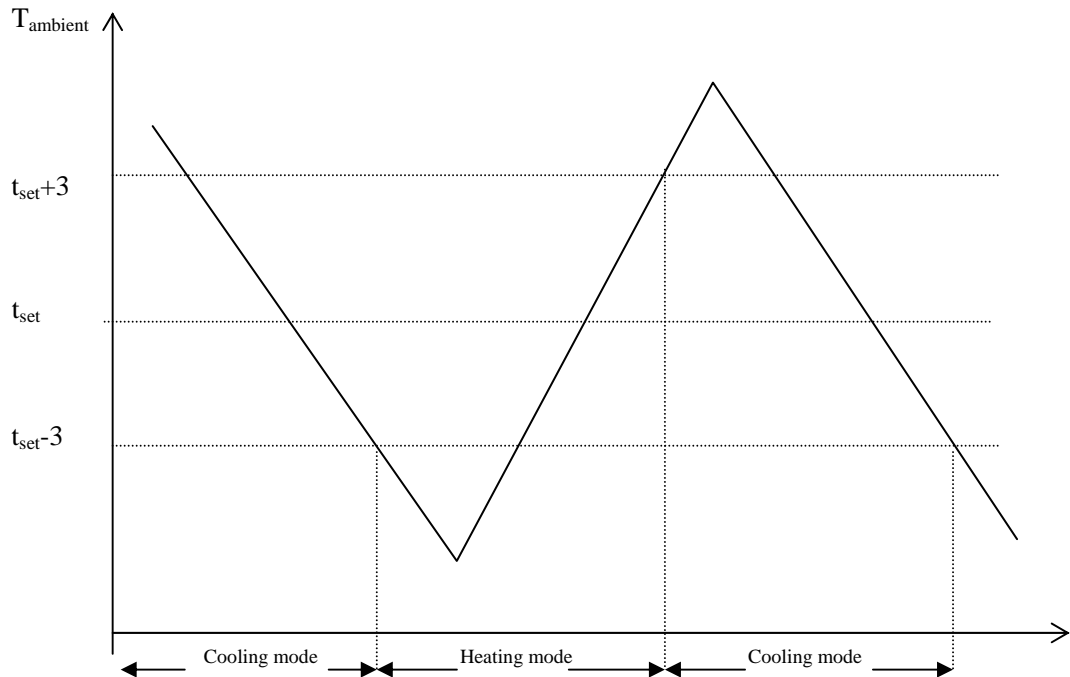

3.6.2 Cooling→heating turnover operation

Cooling→heating: the compressor stops; 50 s later the 4-way valve is activated and 3 minutes more the compressor turns on.

Heating→cooling: the compressor stops, 50 s later the 4-way valve is interrupted and 3 minutes more the compressor turns on.

3.6.3 There is a temperature compensation during the auto-run, which is same as cooling and heating.

3.7 Cooling-run mode

3.7.1 Temperature compensation

Principle for compensation: The compensation is available only if the proper sensor is used and it is not available when it is subject to the sensor on the remote controller.

3.7.2 Outdoor Fan

The outdoor fan’s speeds are divided into two levels which can be changed over according to outdoor ambient temperatures.

When operating at a fixed frequency, the outdoor fan is forced to operate at the high speed.

3.7.3 Indoor fan

When the fan speed is set at the high, medium and low fan speeds, the fan runs at a preset speed. When the fan speed setting is automatic, the fan speed is set based on the difference in room temperatures.

$T_{room}-T_{set}$	Indoor fan speed
$T_{room}-T_{set} \leq 2^{\circ}C$	Low
$2^{\circ}C < T_{room}-T_{set} < 4^{\circ}C$	Medium
$T_{room}-T_{set} \geq 4^{\circ}C$	High

3.7.4 Prevention against condensation and insufficient heat exchange at the low indoor fan speed.

When the indoor fan speed is set at the low fan speed, the compressor’s power is restricted as in the low temperature cooling.

3.7.5 4-way valve

State: It is interrupted in cooling.

Switchover: When initially powered on for cooling, the 4-way valve is interrupted immediately.

When the heating is changed to the cooling, it needs an interval of 50 seconds for the 4-way valve to change over from being activated to being interrupted.

3.7.6 Flap control

The flap opens to the position as shown in the figure below:

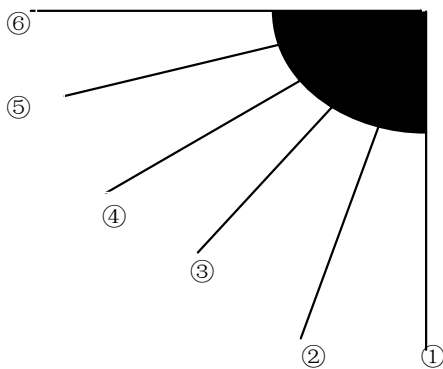

3.7.6.1 When set to open to one of the positions 1 – 6 as shown in the figure above, it is fixed in the corresponding position.

3.7.6.2 When the setting is automatic, it swings between the positions 3 - 6.

3.7.6.3 When set to sweep, it swings between the positions 1 - 6.

3.8 Heating-run mode

3.8.1 Temperature compensation

Principle for compensation: The compensation is available only if the proper sensor is used and it is not available when it is subject to the sensor on the remote controller or line controller.

3.8.2 Indoor fan

The fan speed is set at the high, medium or low fan speed, it operates at a preset speed (in the cold air prevention, it is forced to run at the ultra-low flowrate or stop).

When the fan speed is set in the auto-run, the fan speed setting is made according to the room temperature differences (except for the cold air prevention).

$T_{set}-T_{room}$	Indoor Fan Speed
$T_{set}-T_{room} \leq 2^{\circ}C$	Low

$2^{\circ}\text{C} < T_{\text{set}} - T_{\text{room}} < 4^{\circ}\text{C}$	Medium
$T_{\text{set}} - T_{\text{room}} \geq 4^{\circ}\text{C}$	High

3.8.3 Cold air prevention

In the heating-run, to prevent the indoor fan from blowing cold air, the indoor fan speed is different from the set speed after turning on air-conditioner.

3.8.4 Residual heat blowing off

When the compressor is turned off in the heating run, the indoor fan does not stop at once, but until the indoor evaporator temperature is below 23°C , but for 30 seconds at the latest.

3.8.5 Outdoor fan

The outdoor fan speeds are divided into three levels which can be changed over according to outdoor ambient temperatures.

3.8.6 4-way valve

State: It is electrified in heating.

Switchover: When initially powered on for heating, the 4-way valve is activated immediately.

In the change from cooling to heating, it needs an interval of 50 seconds for the 4-way valve to change over from being interrupted to being activated.

3.8.7 Flap control

The flap opens to the position as shown in the figure below:

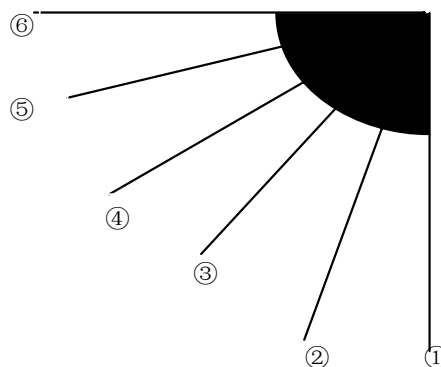

3.8.7.1 During the cold air prevention, regardless of what being set, it is forced to be fixed in position 6 until the cold air prevention is lifted.

3.8.7.2 When set to open in one of the positions 1 – 6 as shown in the figure above, it is fixed in the corresponding position.

3.8.7.3 When the setting is automatic, it swings between positions 1 - 4.

3.8.7.4 When set to sweep, it swings between positions 1 - 6.

3.9 Dehumidifying mode

The dehumidifying mode is illustrated as follows:

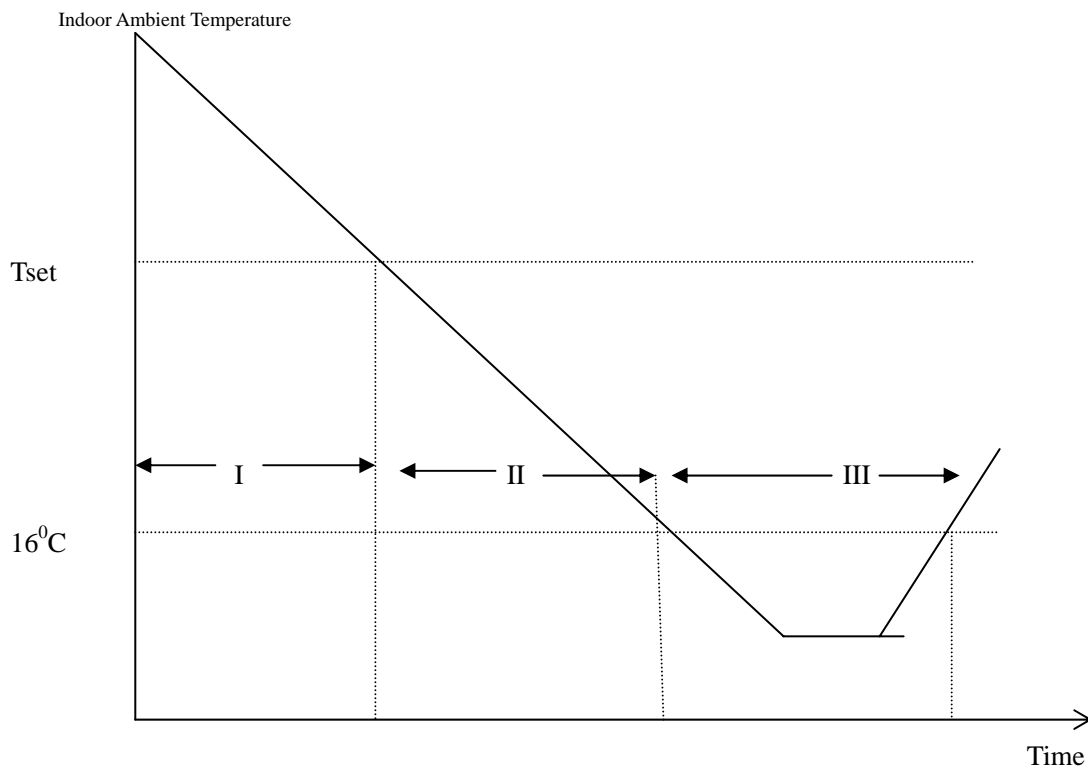

Dehumidifying area I: Operation at the frequency in the range (30 – 80 Hz) according to Δt ($T_{\text{indoor ambient}} - T_{\text{set}}$).

$\Delta t(^{\circ}\text{C})$	f(Hz)
0	30
0.5	30
1	40
1.5	50
≥ 2	60
Efficient	80

Dehumidifying area II: The compressor stops for 5 minutes and operates for 5 minutes at the lowest frequency.

Dehumidifying area III: The compressor stops.

3.10. Air Blowing mode

The outdoor unit does not work while the indoor fan runs with the fan speed selectable at the auto, low, medium and high speeds.

When being auto, the fan speed is determined in the cooling mode (with the temperature setting of 24°C in default).

The high, medium and low fan speeds are same with that in the cooling mode.

3.11 Compressor operating state indication

When the compressor is in operation, The 3 LED indicator lights on the control panel of the outdoor unit indicates the causes of the restriction on the

compressor's current operating frequency.

Symbols for indicator light:: ★: ON ○: flashing ×: OFF				
	LED1	LED2	LED3	The cause of the restriction on the compressor's current operating frequency
1	○	○	○	Normal frequency ascent and descent with no restriction on the frequency
2	×	×	★	Frequency descent or restriction on frequency ascent caused by overcurrent
3	×	★	★	Frequency descent or restriction on frequency ascent caused by anti-freeze in cooling or overload control in heating
4	★	×	★	Frequency descent or restriction on frequency ascent caused by too high compressor discharge temperature
5	×	★	×	Restriction on maximum operation operating frequency caused by too low voltage on the supply circuit
6	★	★	★	Operating at a fixed frequency (when in a capacity measurement or forced operation at a fixed frequency.)
8	★	×	×	Communication frequency drops.

3.12 Special notes

3.12.1 The outdoor unit of this model is electrified by the indoor unit control. After the system starts to operate, the indoor unit supplies the outdoor unit (except for the ventilation mode). If the EEPROM data is read correctly after turning on the power, the indoor unit's beeper rings one time, or if it is not the case the beeper will ring two times and the system cannot be started. Normally, when the indoor unit receives a control signal from the remote controller and emergency button, the system will be started and the beeper will ring two times, and in other cases, the beeper will ring one time.

3.12.2 This model can achieve the power interruption restoration function by the selection of the EEPROM data. The power interruption restoration is applied only for the basic functions (turning ON and OFF, setting temperatures, modes, fan speeds and flap's position) and not for other special functions such as sleep, timing and power-saving run.

7-1. Trouble alarm

Trouble List

Indication on the outdoor unit

When the compressor is interrupted, the outdoor LEDs are used to indicate the troubles listed below:

Symbols for indicator lights: ★: ON O: flashing ×: OFF				
	LED1	LED2	LED3	Troubles
1	×	×	×	Normal
2	×	×	★	Room temperature sensor short-circuited, open circuited or the corresponding test circuit in trouble
3	×	★	×	Indoor heat exchanger temperature sensor short-circuited, open circuited or the corresponding test circuit in trouble
4	★	×	×	Compressor temperature sensor short-circuited, open circuited or the corresponding test circuit in trouble
5	★	×	★	Outdoor heat exchanger temperature sensor short-circuited, open circuited or the corresponding test circuit in trouble
6	★	★	×	Outdoor atmosphere temperature sensor short-circuited, open circuited or the corresponding test circuit in trouble
9	×	×	O	Signal communication abnormal (indoor – outdoor)
10	×	O	×	Power module (IPM) protection
11	★	O	★	Maximum current control
12	★	O	×	Current overload control
13	×	O	★	Compressor discharge temperature too high
14	★	★	O	Over and under-voltage control
18	×	★	O	Compressor housing temperature too high
19	★	★	★	Outdoor memory in trouble
20	×	O	O	Indoor fan motor in trouble
22	O	O	×	DC compressor fails to start
23	O	×	O	DC compressor out of step

Indication by the indoor unit

Press the high power for 4 times in a row and the trouble codes listed below will be displayed.

0	No trouble	16	Anti-freeze or overload control
1	Outdoor coil temperature sensor in trouble	18	DC compressor fails to start
2	Compressor temperature sensor in trouble	19	DC compressor out of step
3	Voltage transformer in trouble		
4	Current transformer in trouble		

7. TROUBLE SHOOTING**AS-09UR4SGNPQ**

5	IPM module protection		
6	Over and under-voltage control	33	Room temperature sensor in trouble
7	Communication trouble	34	Indoor coil temperature sensor in trouble
8	Current overload control	36	Communication between the indoor and outdoor in trouble
9	Maximum current control	39	Indoor fan motor operation abnormal
10	4-way valve changeover abnormal	40	Grid protection alarm (cabinet type)
11	Outdoor EEPROM in trouble	41	Detecting failures by zero-crossing
13	Compressor exhaust temperature too high control		
14	Outdoor ambient temperature sensor in trouble		
15	Compressor housing temperature control		

7-2. Service flow chart

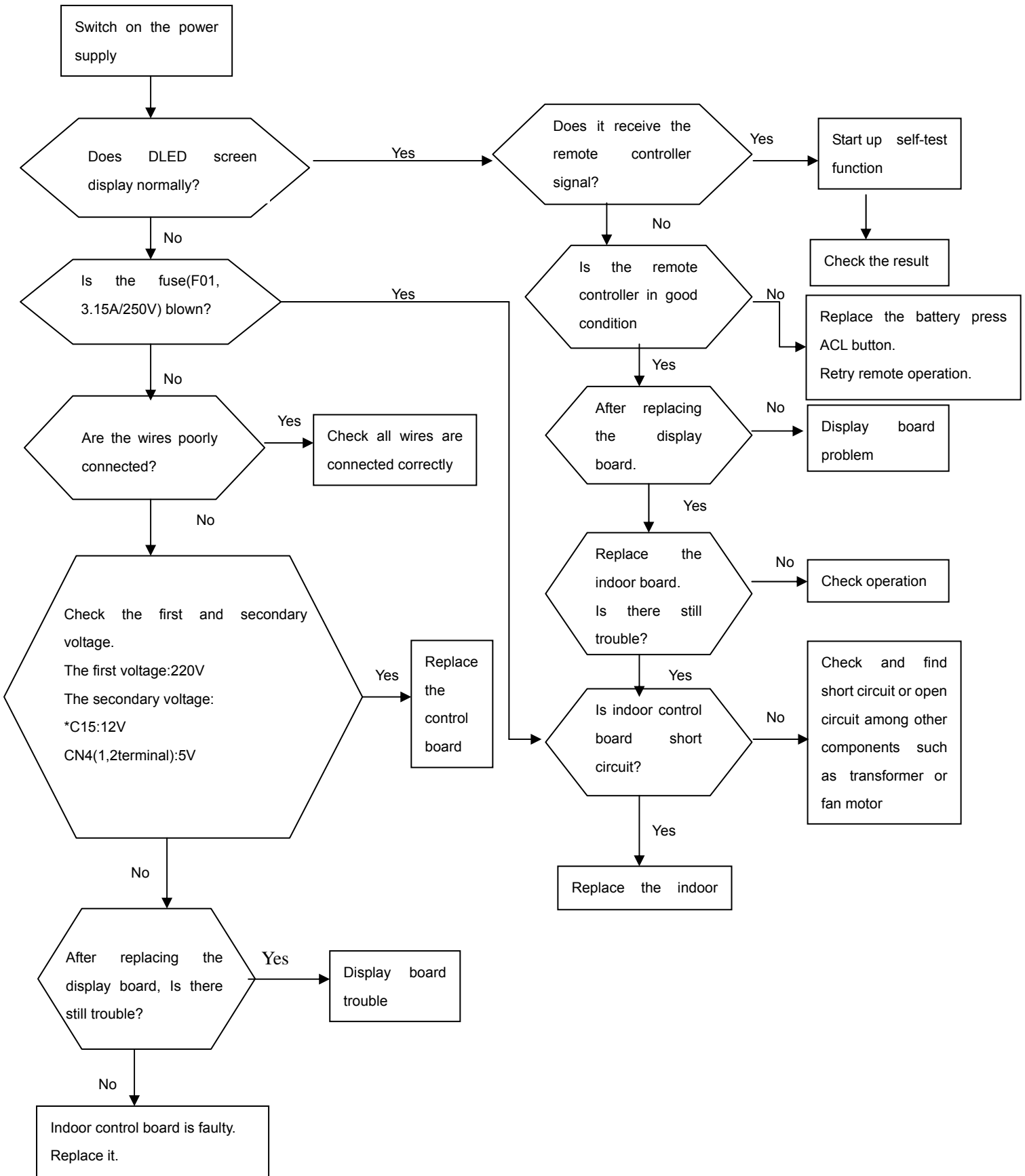

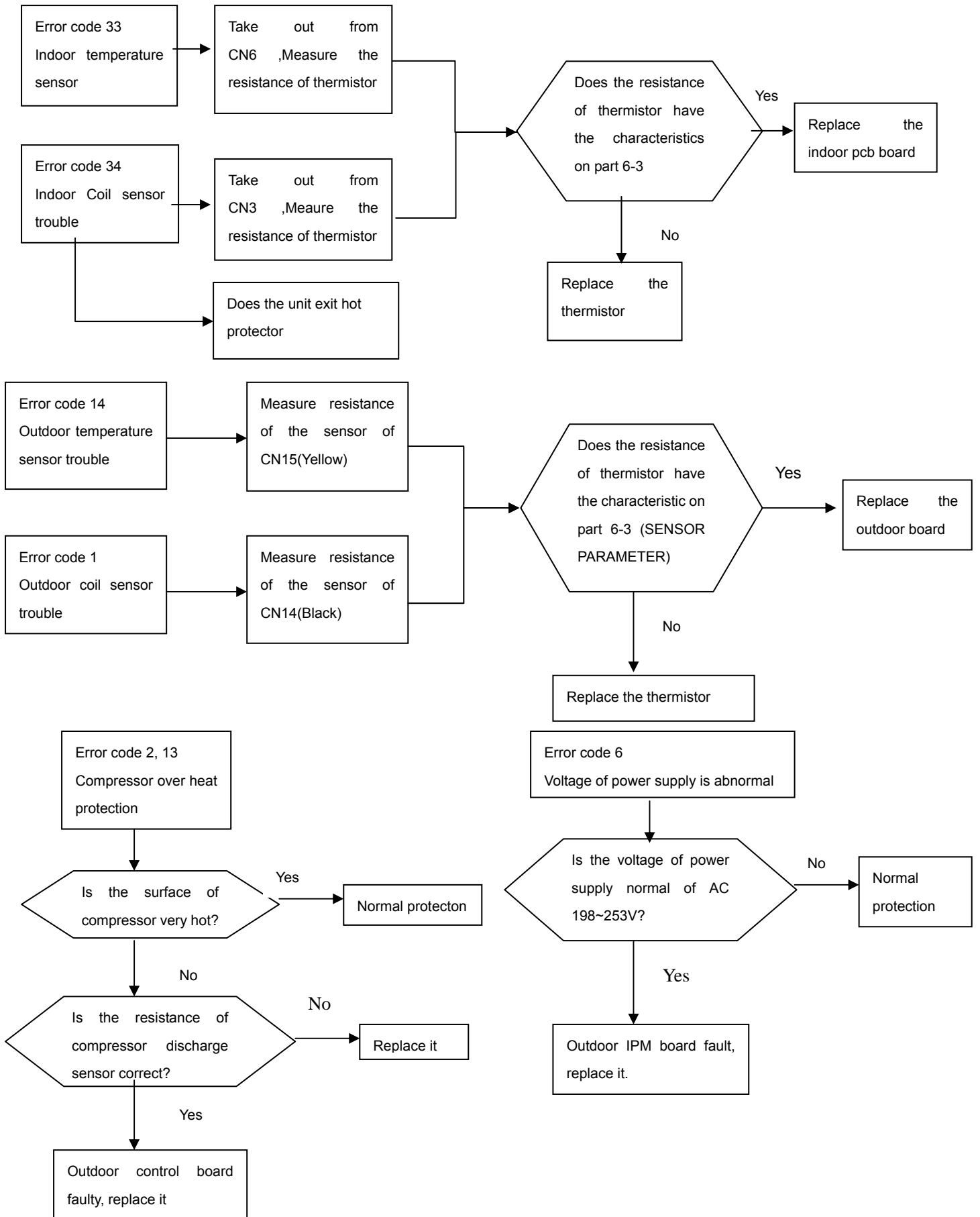

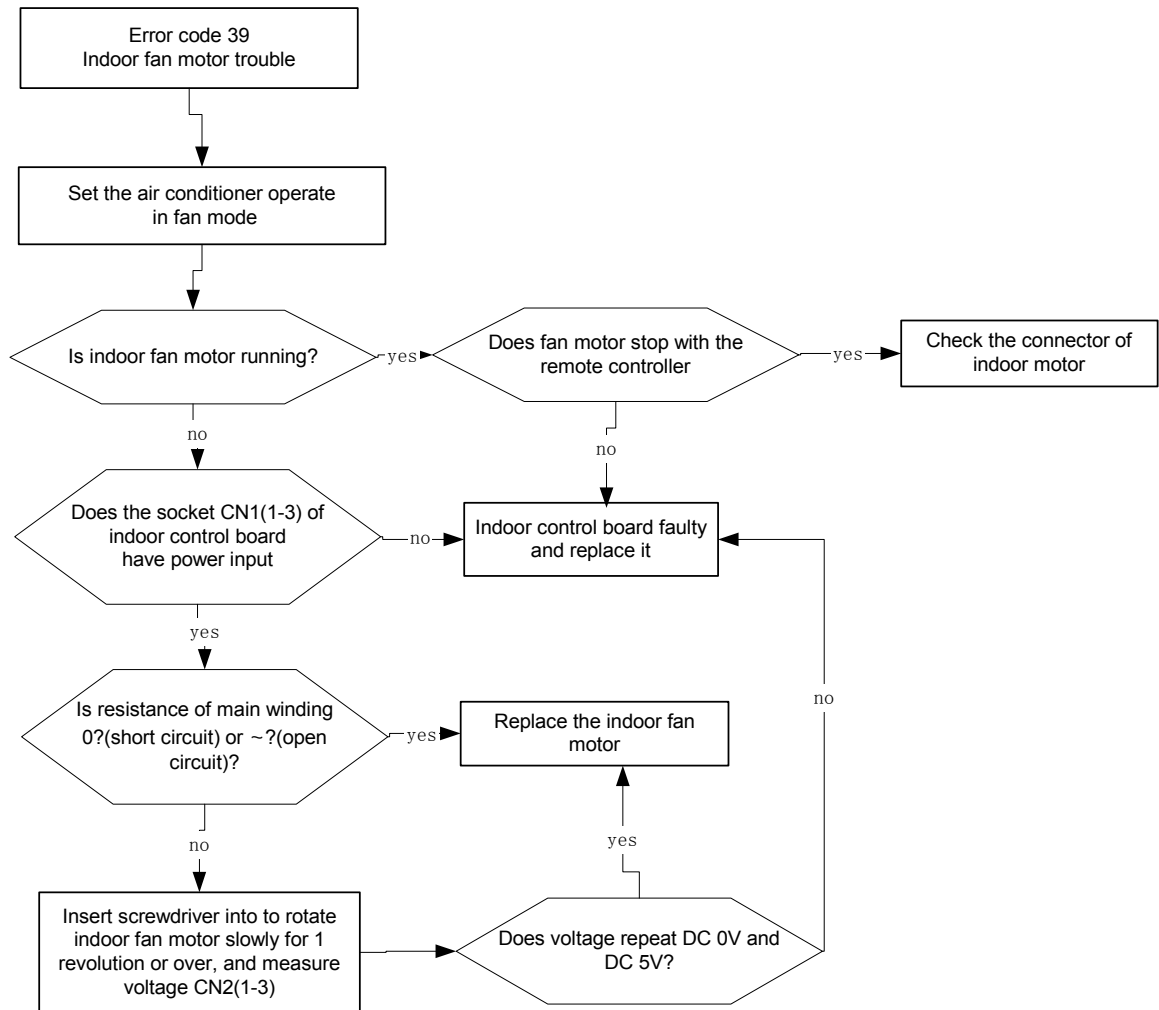

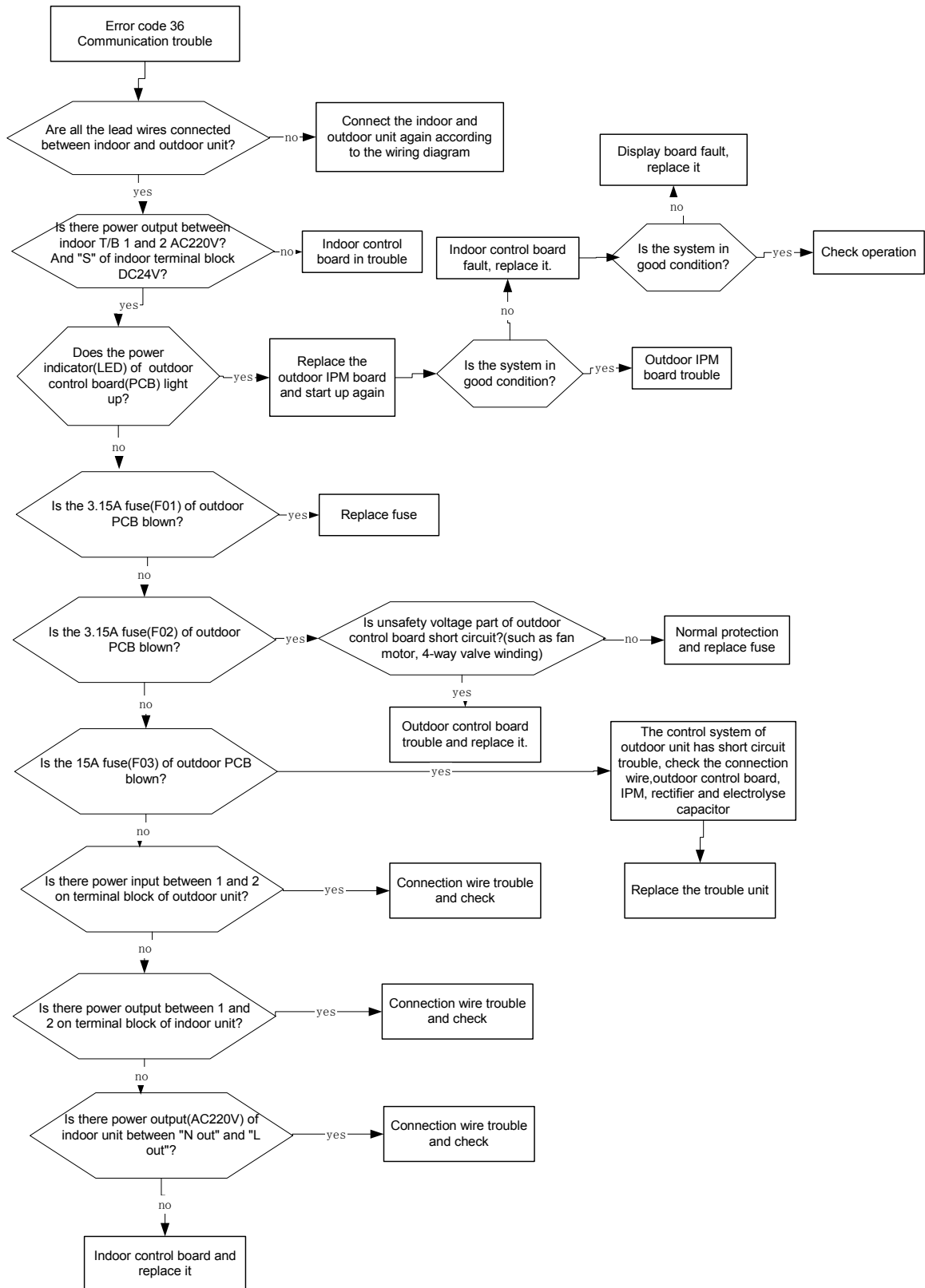

8-1. Check refrigerant system

TEST SYSTEM FLOW

Conditions: ① Compressor is running.

② The air condition should be installed in good ventilation.

Tool: Pressure Gauge

Technique: ① see ② feel ③ test

SEE---Tube defrost.

FEEL---The difference tube temperature.

TEST--- Test pressure.

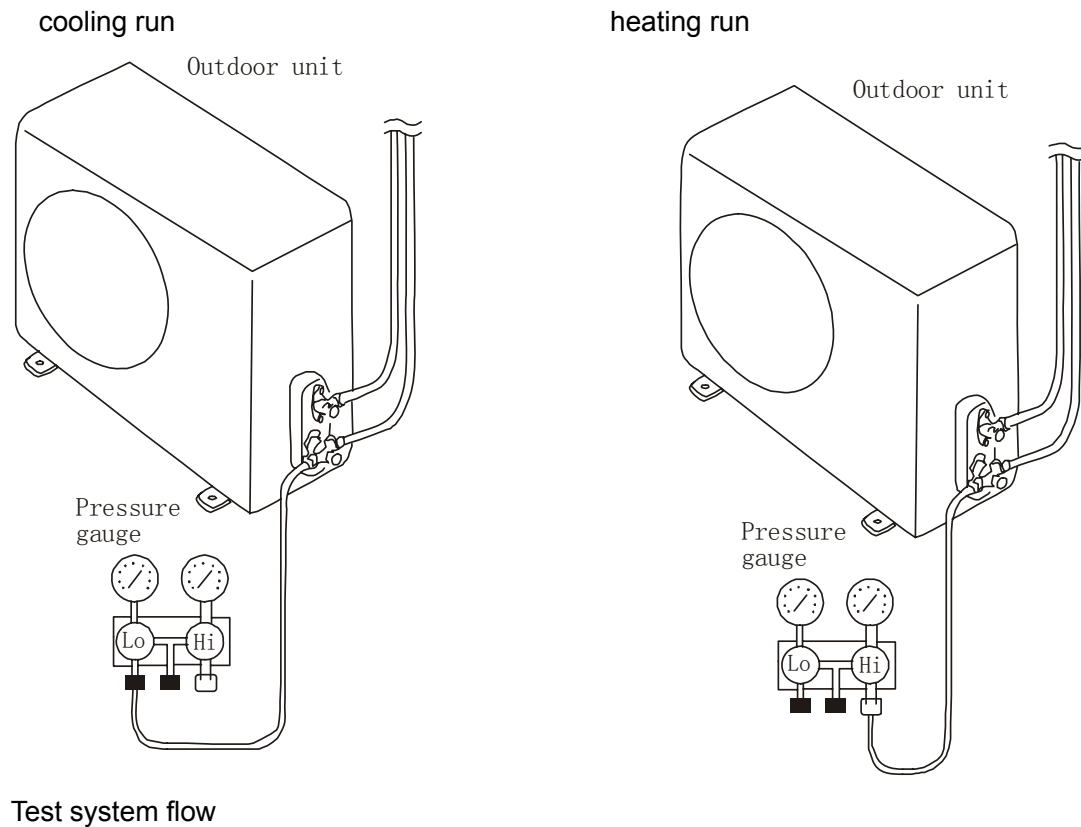

8. CHECKING COMPONENTS

AS-09UR4SGNPQ

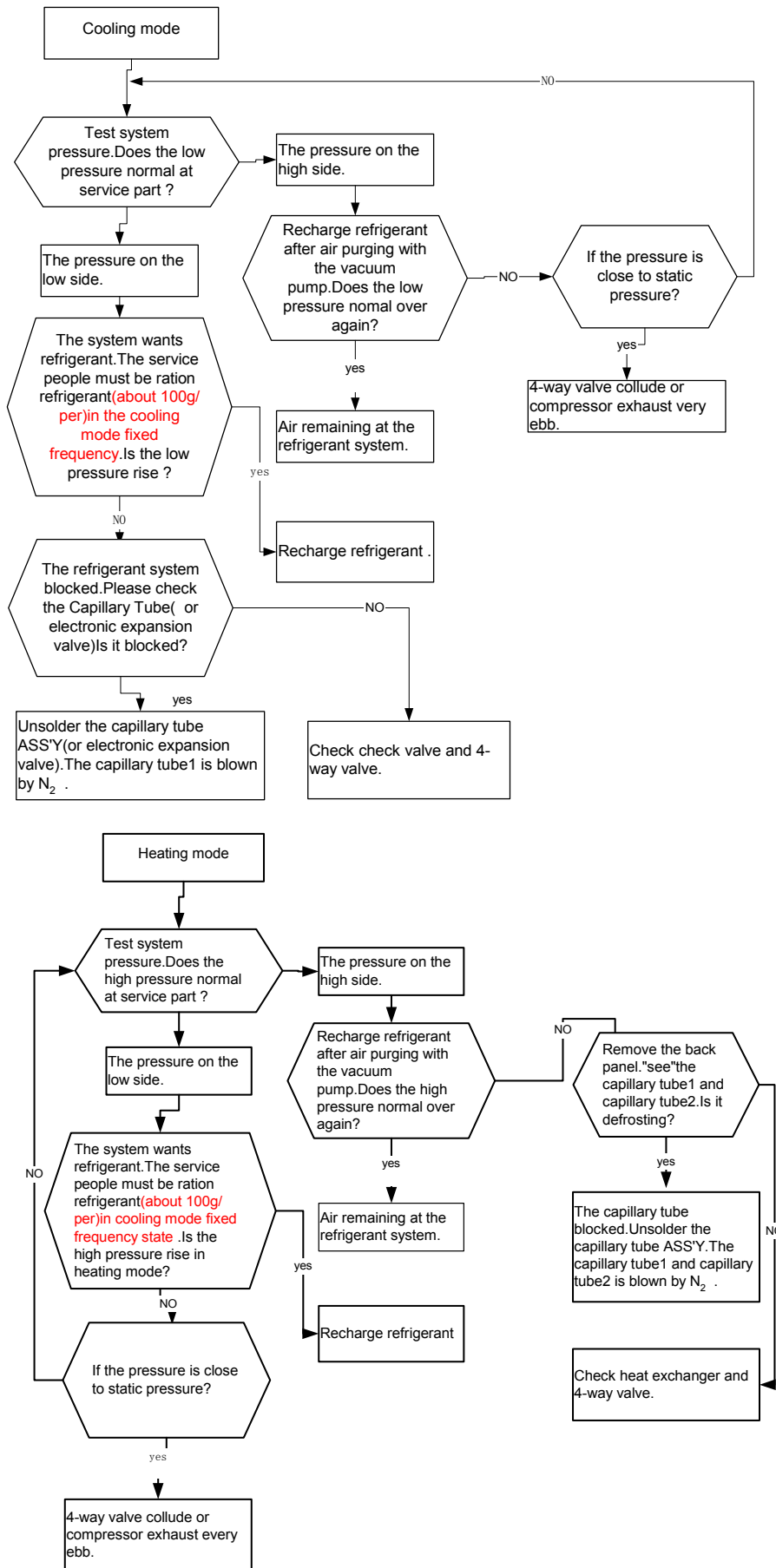

8-2. Check parts unit

1. INDOOR FAN MOTOR

.MOTOR EXAMINE AND REPAIR

Circuit diagram

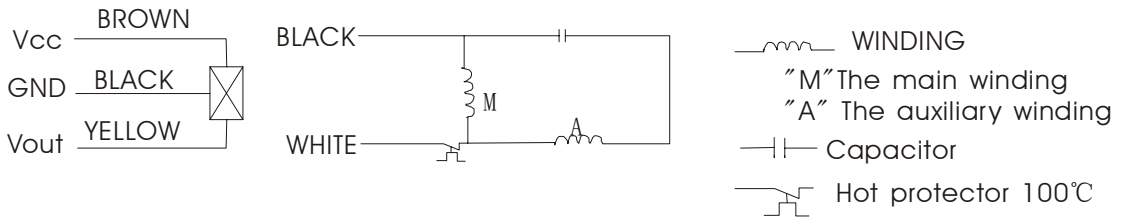

Test in resistance.

TOOL: Multimeter.

Test the resistance of the main winding. The indoor fan motor is fault if the resistance of main winding 0(short circuit)or ∞ (open circuit) .

Test in voltage

TOOL: Multimeter.

Insert screwdriver into to rotate indoor fan motor slowly for 1 revolution or over,and measure voltage "YELLOW" and "GND" on motor. The voltage repeat 0V DC and 5V DC.

Notes:

- 1) Please don't hold motor by lead wires.
- 2) Please don't plug IN/OUT the motor connector while power ON.
- 3) Please don't drop .Hurl or dump motor against hard material.Malfunction may not be observed at early stage after such shock.But it may be found later,This type of mishandling void our warranty.

2. OUTDOOR FAN MOTOR

Circuit diagram

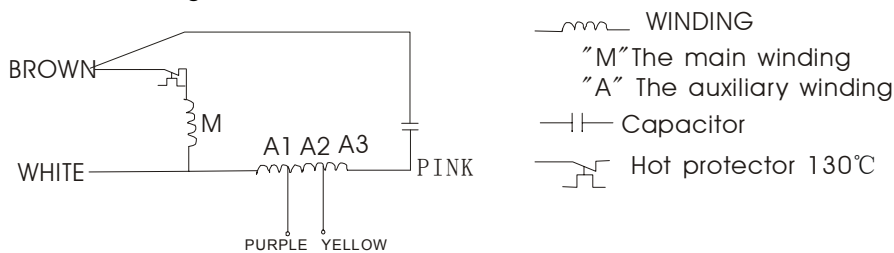

Winding resistance (at 20°C)

(WHITE—BROWN) M: 178 Ω (WHITE—PINK)A: 171 Ω

MOTOR EXAMINE AND REPAIR

Test in resistance.

TOOL: Multimeter.

Test the resistance of the main winding. The indoor fan motor is fault if the resistance of main winding 0(short circuit)or ∞ (open circuit) .

Notes: 1) Please don't hold motor by lead wires.

- 2) lease don't plug IN/OUT the motor connector while power ON.
- 3) lease don't drop hurl or dump motor against hard material.Malfunction may not be observed at early stage after such shock.But it may be found later,This type of mishandling void our warranty.

3. COMPRESSOR

1. Coil Resistance: 0.71Ω (at 20°C)

2. COMPRESSOR EXAMINE AND REPAIR.

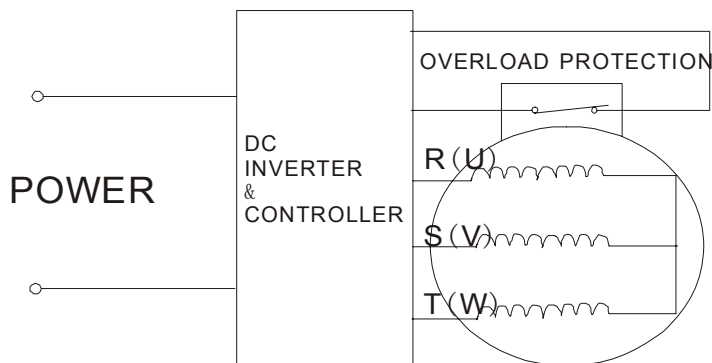

Test in resistance.

TOOL: Multimeter.

Test the resistance of the winding. The compressor is fault if the resistance of winding 0 (short circuit) or ∞ (open circuit)

Familiar trouble: 1) Compressor motor lock. 2) Discharge pressure value approaches static pressure value .3) Compressor motor winding abnormality.

Notes: 1) Don't put a compressor on its side or turn over.

2) Please assembly the compressor in your air conditioner rapidly after removing the plugs. Don't place the comp. In air for along time.

3) Avoiding compressor running in reverse caused by connecting electrical wire incorrectly.

4) Warning! In case AC voltage is impressed to compressor, the compressor performance will belower because of its rotor magnetic force decreasing.

4. OVERLOAD PROTECTION

OVERLOAD PROTECTION SPECIFICATIONS

1) Reset Temperature: $90 \pm 5^\circ\text{C}$

2) Trip Temperature: $120 \pm 4^\circ\text{C}$

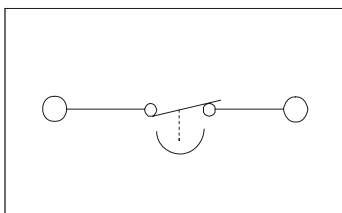

5. INDUCTANCE

Familiar error: 1) Sound abnormality 2) Insulation resistance disqualification.

6. FILTER

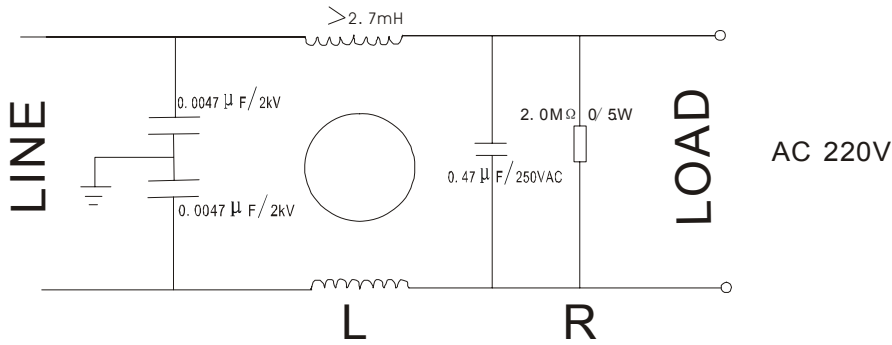

Test in resistance.

TOOL: Multimeter.

Test the resistance of “LOAD”port. The filter is fault if the resistance of winding 0(short circuit)or∞ (open circuit)

7. STEPPER MOTOR

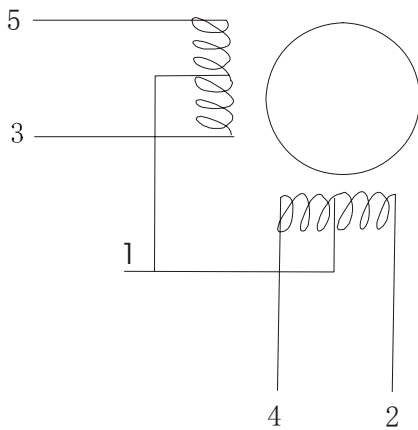

Test in resistance.

TOOL: Multimeter.

Test the resistance of winding. The stepper motor is fault if the resistance of winding 0(short circuit)or∞ (open circuit) .

8-2-3. Check others

1. FUSE

Checking continuity of fuse on PCB ASS'Y.

- 1) Remove the PCB ASS'Y from the electrical component box..Then pull out the fuse from the PCB ASS'Y (Fig.1)

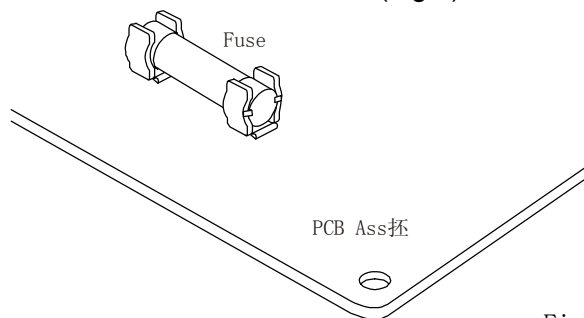

Fig. 1

- 2) Check for continuity using a multimeter as shown in Fig.2.

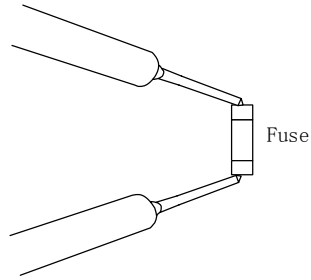

Fig. 2

2.CAPACITOR

Remove the lead wires from the capacitor terminals, and then place a probe on the capacitor terminals as shown in Fig.3.Observe the deflection of the pointer, setting the resistance measuring range of the multimeter to the maximum value.

The capacitor is “good” if the pointer bounces to a great extent and then gradually returns to its original position.

The range of deflection and deflection time differ according to the capacity of the capacitor.

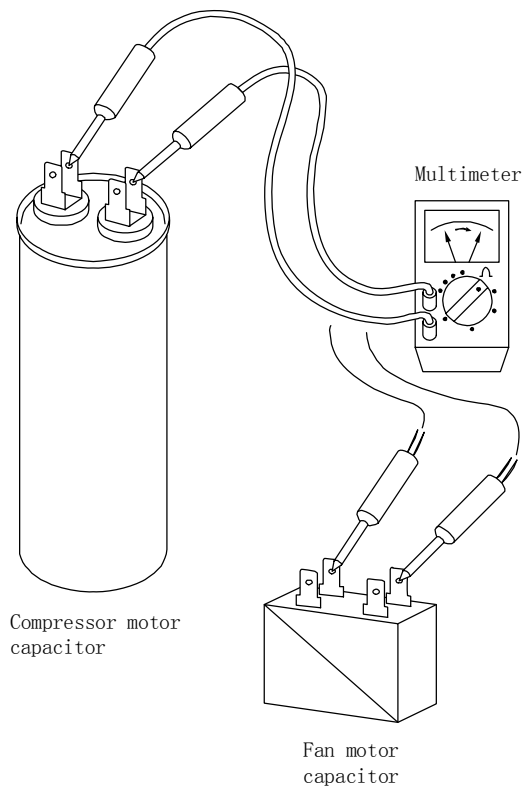

Fig. 3

9-1.INDOOR

OPERATION PROCEDURE AND PHOTOS

1. Remove the installation plate

Take out the screw of the installation plate and remove the installation plate.

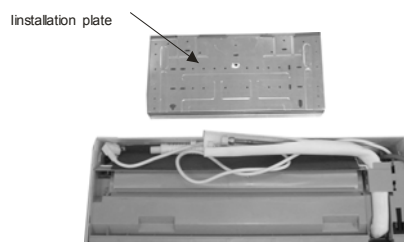
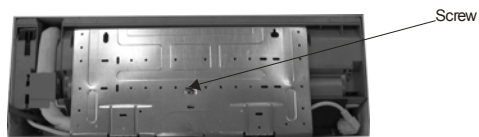

2. Remove the mounting plate

Take out the mounting plate .

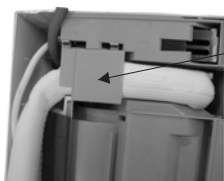

Mounting plate

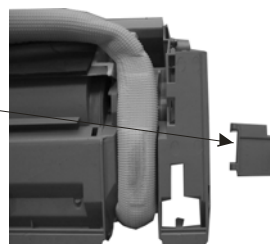

3. Remove the front panel ASS Y

1) Hold the both sides of the front panel and drag it towards oneself and remove it.

2) Take away the air filters in the grille.

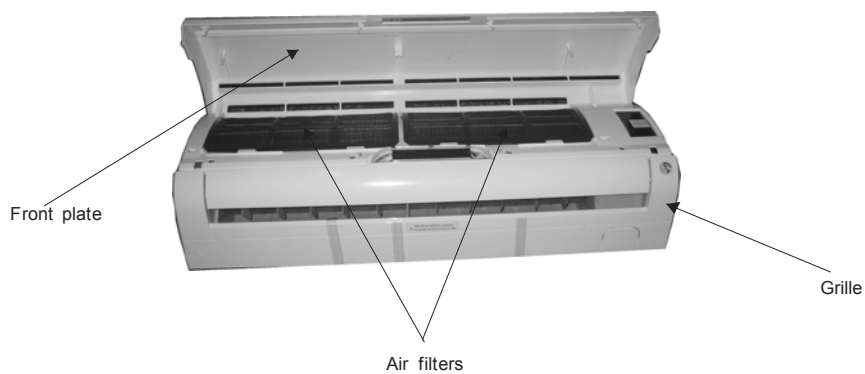

3) Take out the display panel and remove the display panel.

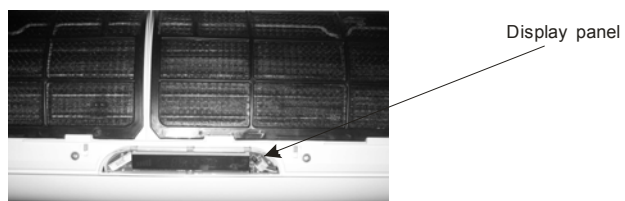

- 4) Take out the 4 screws of the grille and remove the grille.
grille and remove the grille.

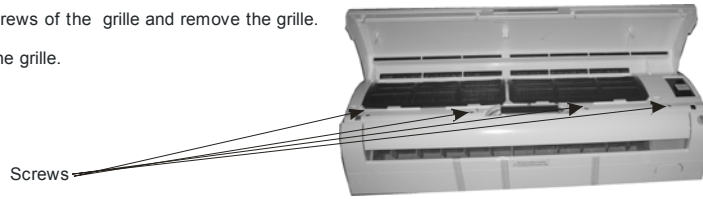

4. Remove the electrical control box

- 1) Take out the 1 screw of the electrical cover and remove it.

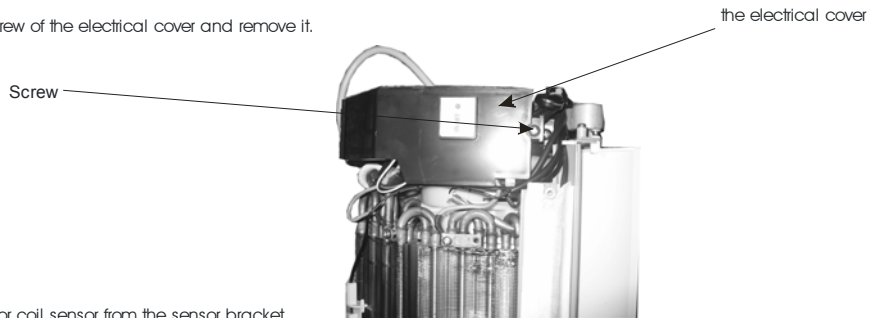

- 2) Remove the indoor coil sensor from the sensor bracket.

- 3) Take out the 3 screws of the electrical control box and disconnect all the connectors on the printed circuit board and evaporator ASS'Y ,

Take out the room temperature sensor and coil sensor on the evaporator .

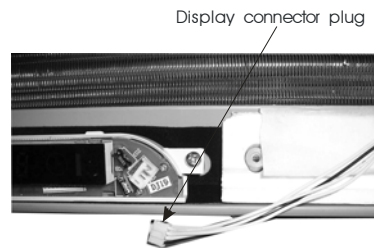
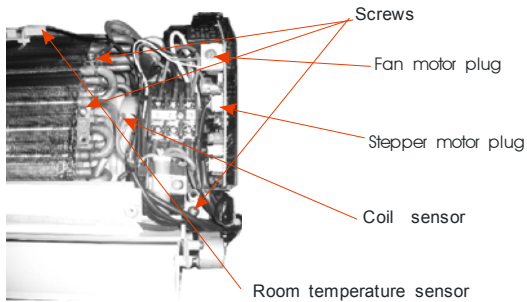

then remove the electrical box.

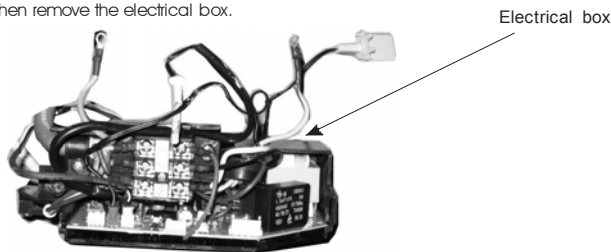

5. Remove the evaporator .

- 2) Take out the 6 screws of the evaporator supportor and remove the evaporator supportor.

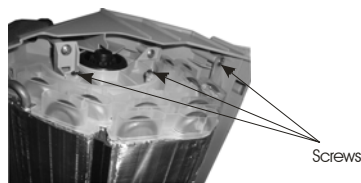

then remove the evaporator.



6. remove the indoor cross-flow fan and fan motor

1) Take out the 2 screws of the cover and remove the cover of the bearing housing.

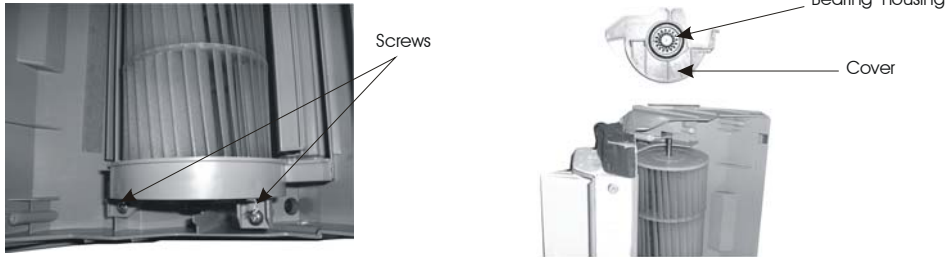

2) Take out the 3 screws of the motor cover and remove the motor cover. Take out the 1 special screw connecting the cross-flow fan.

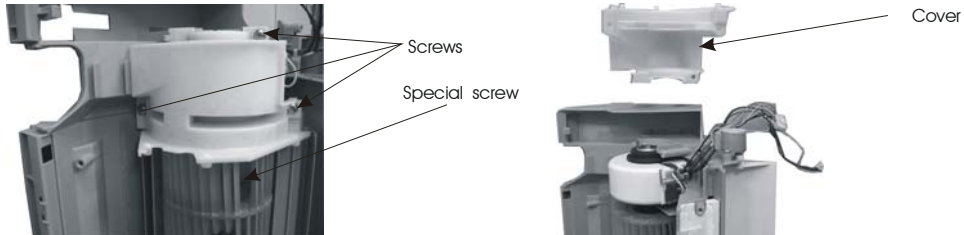

3) Remove the fan motor and the cross-flow fan.



7. Remove the base ASS'Y.

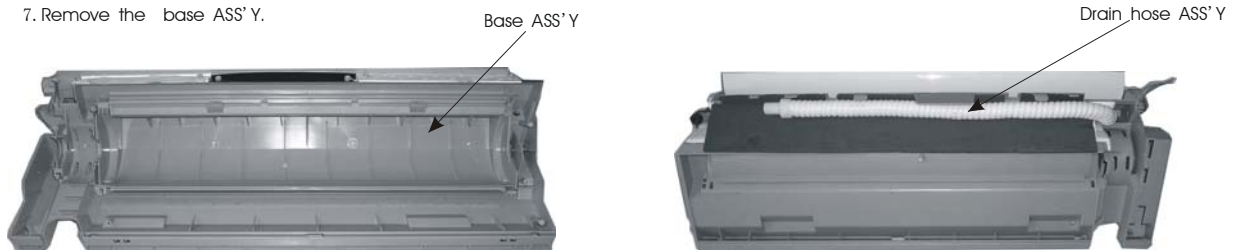

9-2. Outdoor

OPERATION PROCEDURE AND PHOTOS

1. Remove the top panel the front panel

1) Take out the 6 screws of the top panel and remove the top panel.

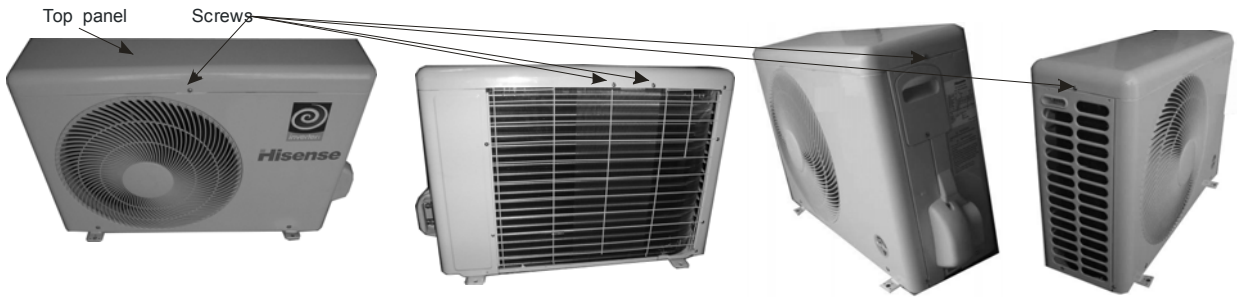

2. Remove the front panel

1) Take out the 9 screws of the front panel and remove the panel.

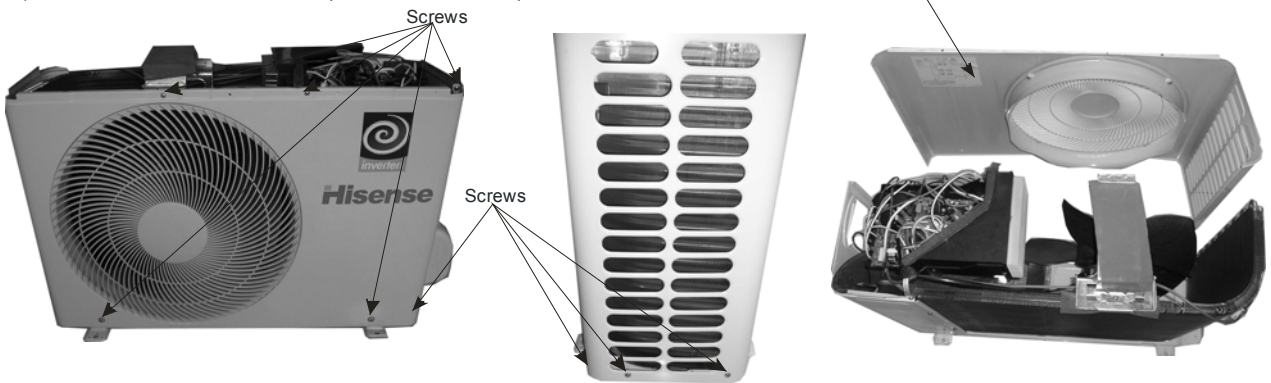

3. Remove the side panel

1) Take out the 1 screw of the valve cover and remove the valve cover.

2) Take out the 1 screw of the side cover and remove the cover.

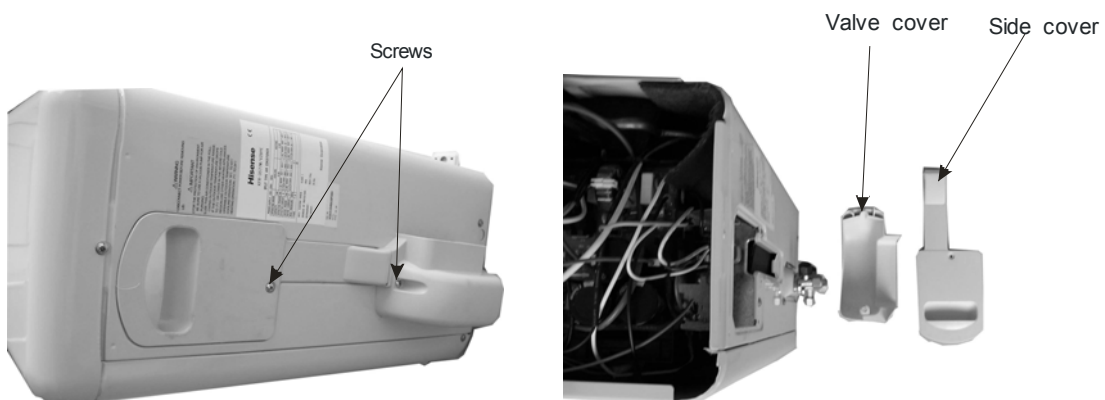

3) Take out the 8 screws of the side panel.

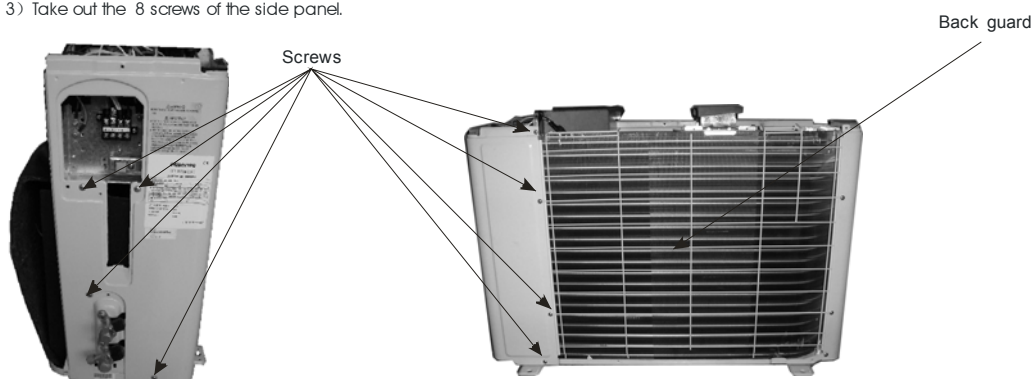

4) Remove the side panel.

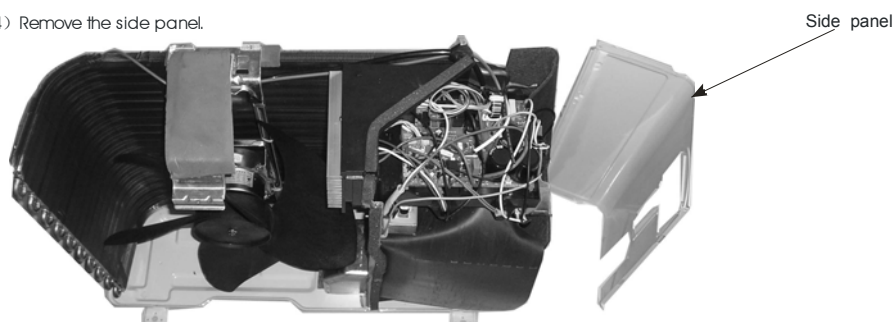

4. Remove the electrical control box

1) Take out the 1 screw of the electrical box cover and remove it.

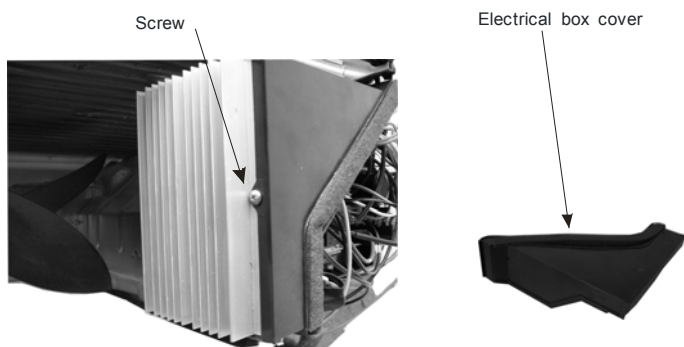

2) Disconnect all the wires and plugs in the electrical control box and the other parts.

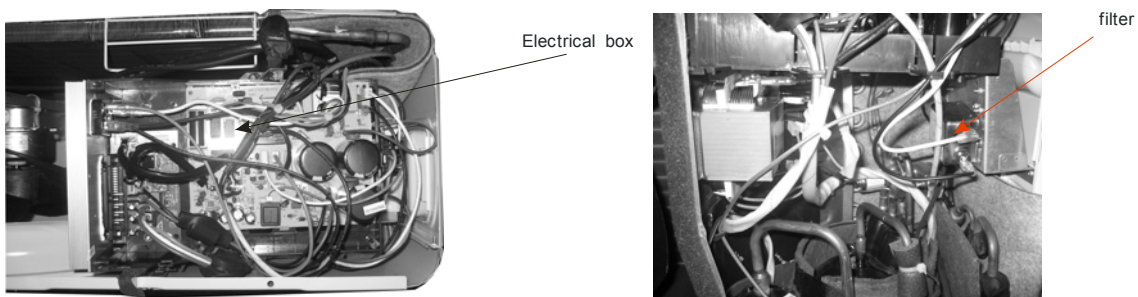

3) Take out the 1 screw of the electrical control box and remove electrical control box.

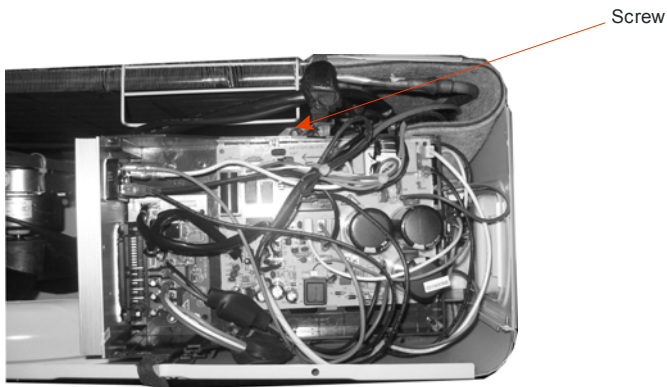

5. Remove the fan ,fan motor and fan supportor .

- 1) Take out the special nut of the fan and remove the fan.
- 2) Take out the 4 screws of the fan motor and remove the fan motor.
- 3) Take out the 2 screws of the fan supportor and remove the fan supportor.

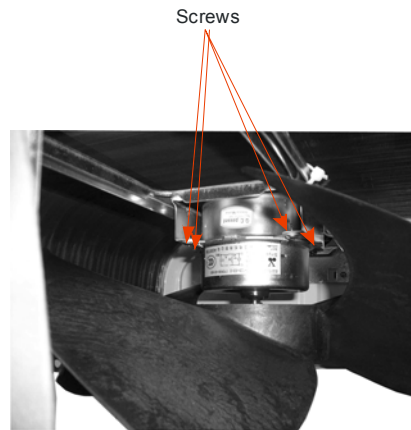
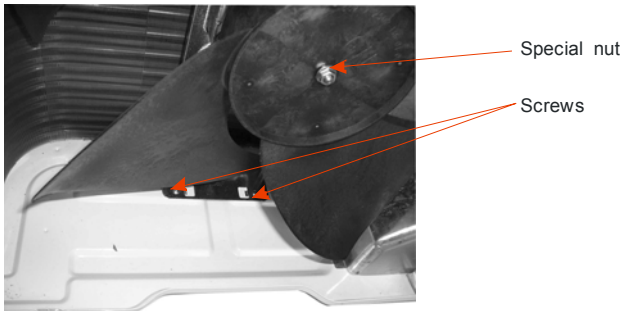

6. Remove the partition plate .

- 1) Take out the 2 screws of the inductance take out the 1 screw of capacitor take out the 1 screw of capacitor.
- 2) Take out the 3 screws of the partition plate and remove the partition plate.
- 3) Take out the 1 screws of the cover .

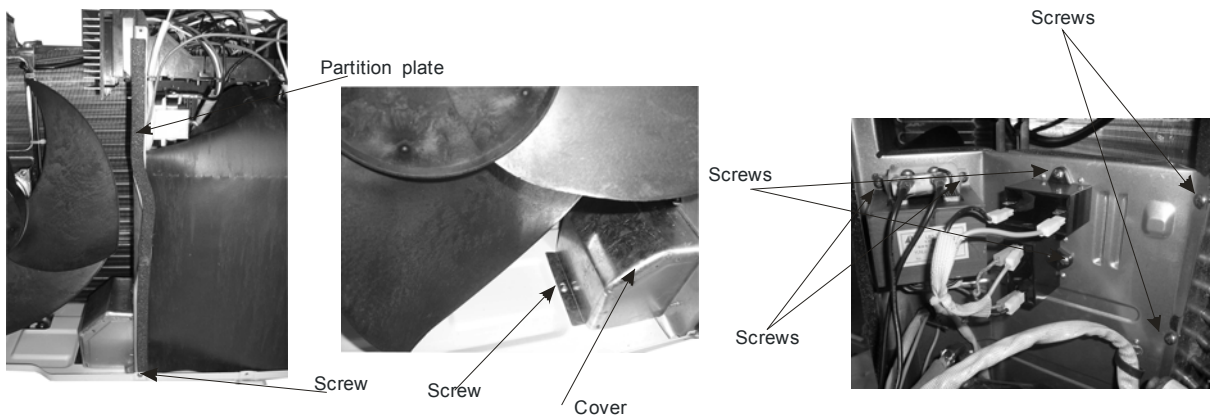

- 4) Remove the partition plate and cover
- 5) Take out the 3 screws of cover Remove the partition

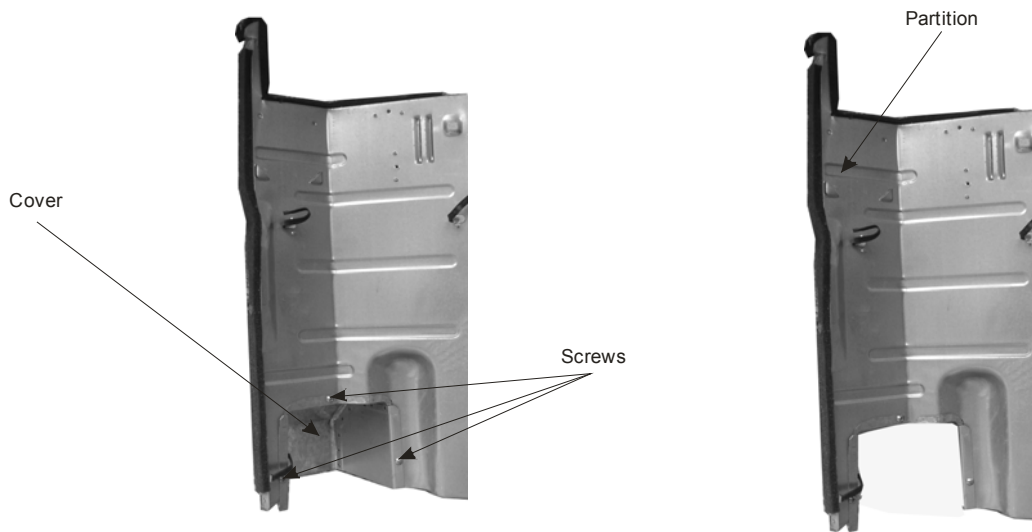

- 7. Remove the inductance at the base
- 5) Take out the 4 screws of cover Remove the inductance

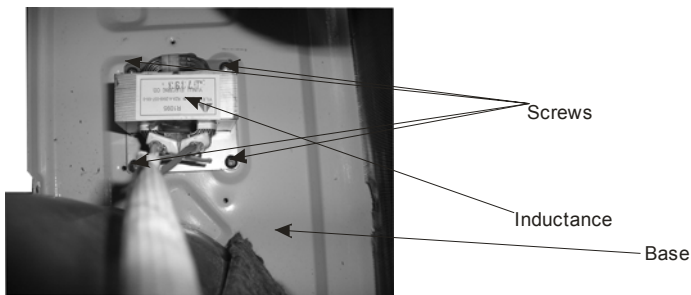

- 8. Check-up the other parts of the outdoor units
- 1) Check-up the condenser ass'y. 2) Check-up the compressor ass'y.
- 3) Check-up the base ass'y. 4) Check-up the 4 way valve, capillary tube and check valve.

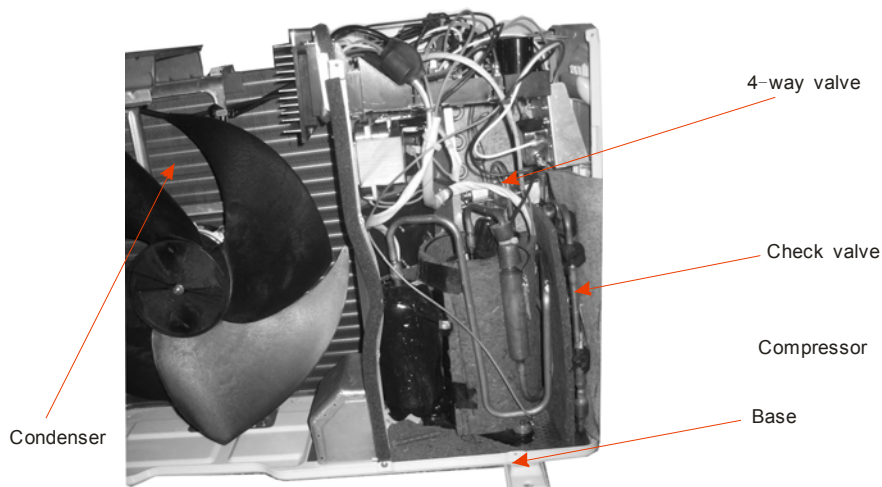

10. PARTS LIST

AS-09UR4SGNPQ

10-1. Indoor

1. Parts

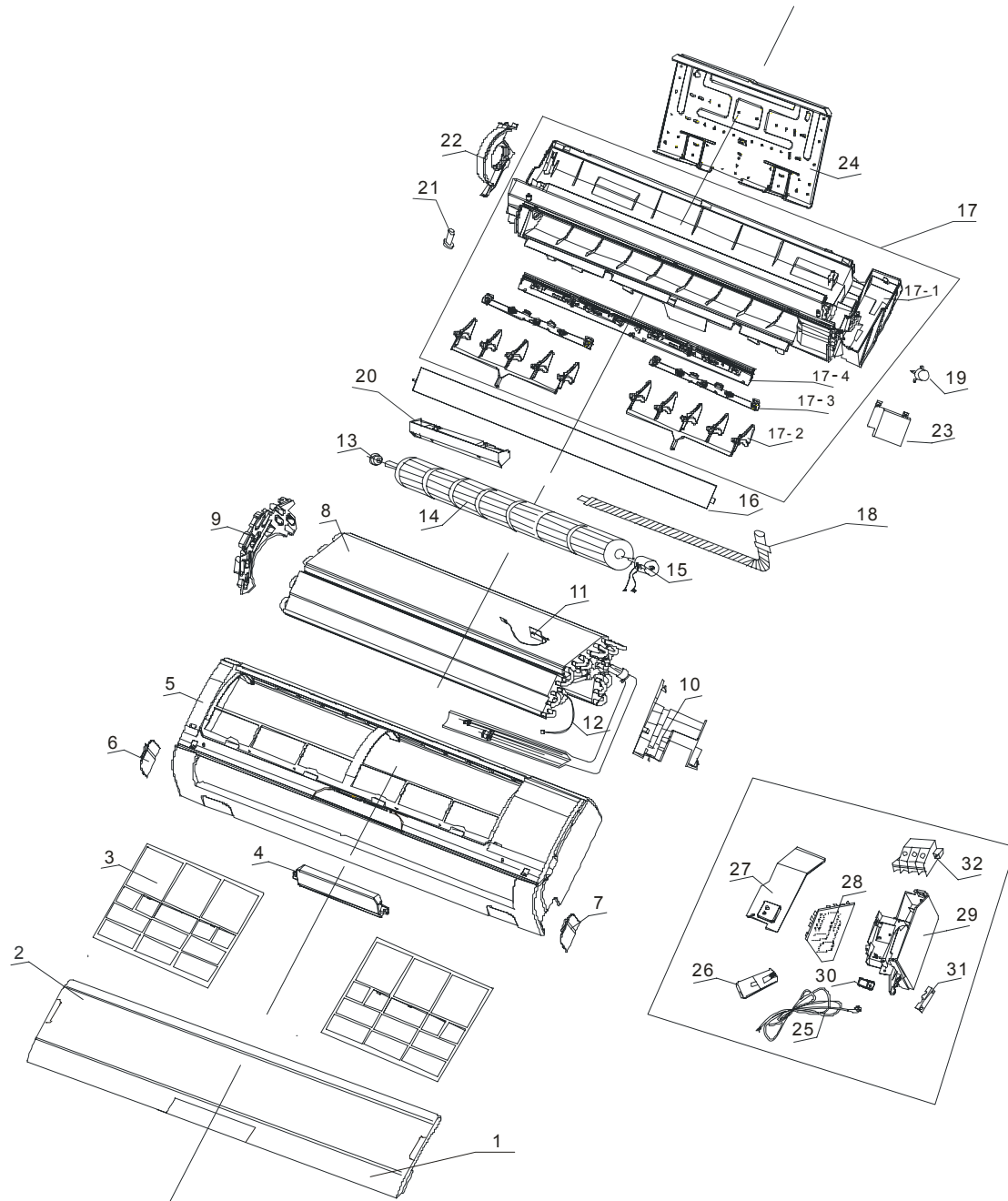

2. LIST

Key No.	Part No.	Code name	Description	Q'ty
1	K31470321	1393633	Front Panel	1
2	K31470201	8007483	Front Panel	1
3	RZA-0-2307-006-01-0	1203049	Air Filter Ass'y	2
4				
5	RZA-2-1501-076-XX-0	001265	grill Ass'y	1

10. PARTS LIST**AS-09UR4SGNPQ**

6	RZA-2-2369-067-XX-0	1203645	Left Down Cover	1
7	RZA-2-2369-068-XX-0	1203646	Right Down Cover	1
8	RZA-0-4116-313-XX-1	1205665	Evaporator Ass'y	1
9	RZA-2-2219-043-XX-0	1203331	Evaporator bracket	1
10	RZA-2-2514-113-XX-0	1203664	Motor Cover	1
11	RZA-0-5259-080-XX-0	1202893	Indoor temp Sensor Ass'y	1
12	RZA-0-5259-105-XX-0	1201218	Coil Sensor Ass'y	1
13	RZA-0-2510-106-XX-1	1203072	Bearing Ass'y	1
14	RZA-2-2509-123-01-0	1203264	Cross-Flow Fan Ass'y	1
15	RZA-0-0000-143-XX-0	1201862	Fan motor Ass'y	1
16	RZA-2-1523-056-XX-0	1203287	flap	1
17	RZA-0-2201-140-XX-0	1203750	Base ASS'Y	1
17-1	RZA-0-2231-019-XX-0	1203273	Base	1
17-2	RZA-2-1519-037-XX-0	1203280	Blade	2
17-3	RZA-2-2478-112-XX-0	1203661	flap fixed plate	2
17-4	RZA-2-2360-004-XX-0	1203627	Inner Flap	1
18	K33930002	1334532	Drainage Hose Ass'y	1
19	RZA-0-0000-101-XX-0	1200853	Stepper Motor	1
20	K36430243	1377127	display ass'y	1
21	RZA-2-2348-005-XX-0	1203590	Drainage Plug	1
22	RZA-2-2514-112-XX-0	1204031	Rubber Ring	1
23	RZA-2-2362-032-XX-0	1203639	fixed board	1
24	RZA-2-2230-114-XX-0	1203356	Installation Ass'y	1
25	K18410037	1344017	Power cord	
26	K36R10003	1327134	Remote Controller	1
27	RZA-0-5315-023-XX-0	1203207	Electrical Control Box Cover	1
28	K36111249	1393691	Control Board Ass'y	1
29	RZA-2-5307-051-01-1	1203964	Electrical Control Box	1
30	852-2-5304-179-02-0	1204041	power cord clip	1
31	RZA-2-5304-016-01-2	1203961	fixed clip	1
32	4-2379-123-02-0	1304376	Terminal Board	1

10. PARTS LIST

AS-09UR4SGNPQ

10-2. Outdoor

1. Parts

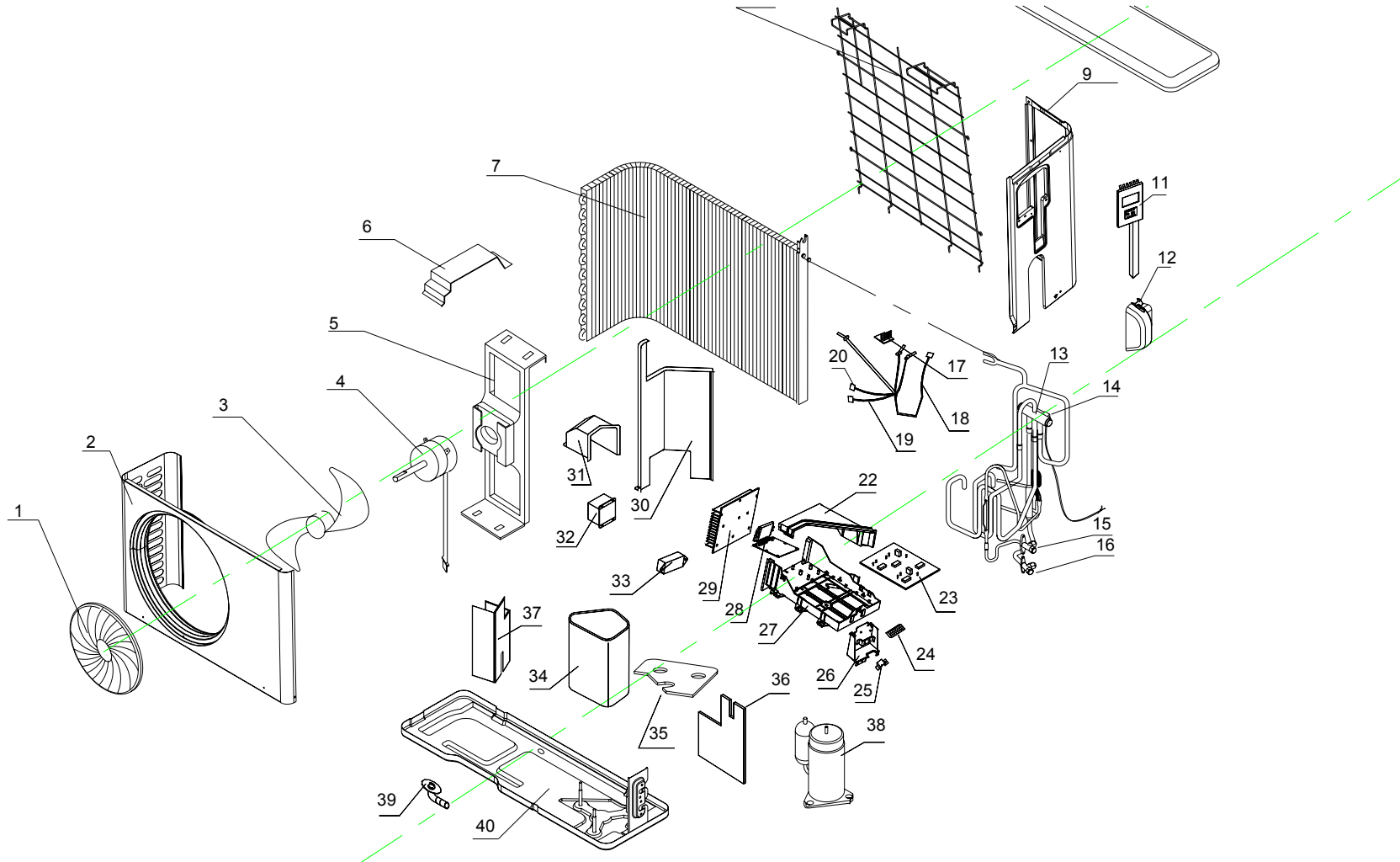

10. PARTS LIST**AS-09UR4SGNPQ****2. LIST**

	PART NAME	Code name	PART NO.	Q'TY
1	FAN GUARD	1203681	852-2-1321-156-02-0	1
2	FRONT PANEL	1203959	RZA-2-1112-024-XX-0	1
3	PROPELLOR FAN	1203264	RZA-2-2509-123-01-0	1
4	FAN MOTOR ASSY	1206041	RZA-0-0000-043-XX-0	1
5	FAN SUPPORTER	1203315	RZA-2-2354-031-XX-0	1
6	STRENGTHEN PANEL ASS'Y	1203761	RZA-0-2208-036-XX-0	1
7	CONDENSER ASSY	1306312	RZA-0-4102-631-XX-0	1
8	BACK GUARD	1203577	RZA-2-1111-014-XX-0	1
9	SIDE PANEL ASSY	1203954	RZA-0-1104-014-XX-0	1
10	TOP COVER ASSY	1203956	RZA-0-2309-040-XX-0	1
11	SIDE COVER ASSY	1205229	852-0-5302-161-00-1	1
12	VALVE COVER	1204053	852-2-2369-329-01-1	1
13	4-WAY VALVE	1203390	RZA-0-4509-016-XX-0	1
14	4-WAY VALVE WINDING	1202908	RZA-0-2649-002-XX-0	1
15	1/4 VALVE ASSY	1204869	RZA-0-4515-02B-41-0	1
16	3/8 VALVE ASSY	1204871	RZA-0-4518-01B-41-0	1
17	SENSOR MOUNT ASSY	1204958	RZA-2-5303-054-XX-0	1
18	AMBIENT TEMPERATURE SENSOR	1205018	4-5259-395-01-0	1
19	COIL TEMPERATURE SENSOR	1201221	RZA-0-5259-106-XX-0	1
20	DISCHARGE TEMPERATURE SENSOR	1201219	RZA-0-5259-090-XX-0	1
21				
22	ELECTRICAL BOX COVER ASSY	1204048	RZA-0-5302-011-XX-1	1
23	CONTROL BOARD ASSY	1338175	K36411506	1
24	TERMINAL PANEL	1201078	RZA-0-5306-026-XX-0	1
25	CLIP ASSY	1304089	RZA-2-5304-092-XX-0	1
26	TERMINAL BOARD ASSY	1203940	RZA-0-5306-053-XX-5	1
27	ELECTRICAL BOX	1315782	K33530007	1
28	IPM ASSY	1333773	K36470066	1
29	RADIATOR	1314204	K33AE0003	1
30	PARTITION SUPPORT PLATE	1204042	RZA-0-2209-060-XX-0	1
31	COVER ASSY	1204046	RZA-0-5315-016-XX-0	1
32	INDUCTANCE	1205797	RZA-4-2649-066-XX-0	1
33	FILTER	1336846	K13410009	1
34	NOISE DEFENING COVER(1)	1205547	RZA-2-2476-135-XX-0	1
35	NOISE DEFENING COVER(2)	1205549	RZA-2-2476-138-XX-1	1
36	NOISE DEFENING COVER(3)	1205548	RZA-2-2476-137-XX-0	1

10. PARTS LIST**AS-09UR4SGNPQ**

37	NOISE DEFENING COVER(4)	1304957	RZA-2-2476-200-XX-0	1
38	COMPRESSOR ASSY	1319474	K37210044	1
39	DRAINAGE HOSE	1204014	852-2-2228-132-02-0	1
40	BASE ASSY	1203756	RZA-0-2202-179-XX-0	1