

INSTRUCTION BOOK

CHEST FREEZER

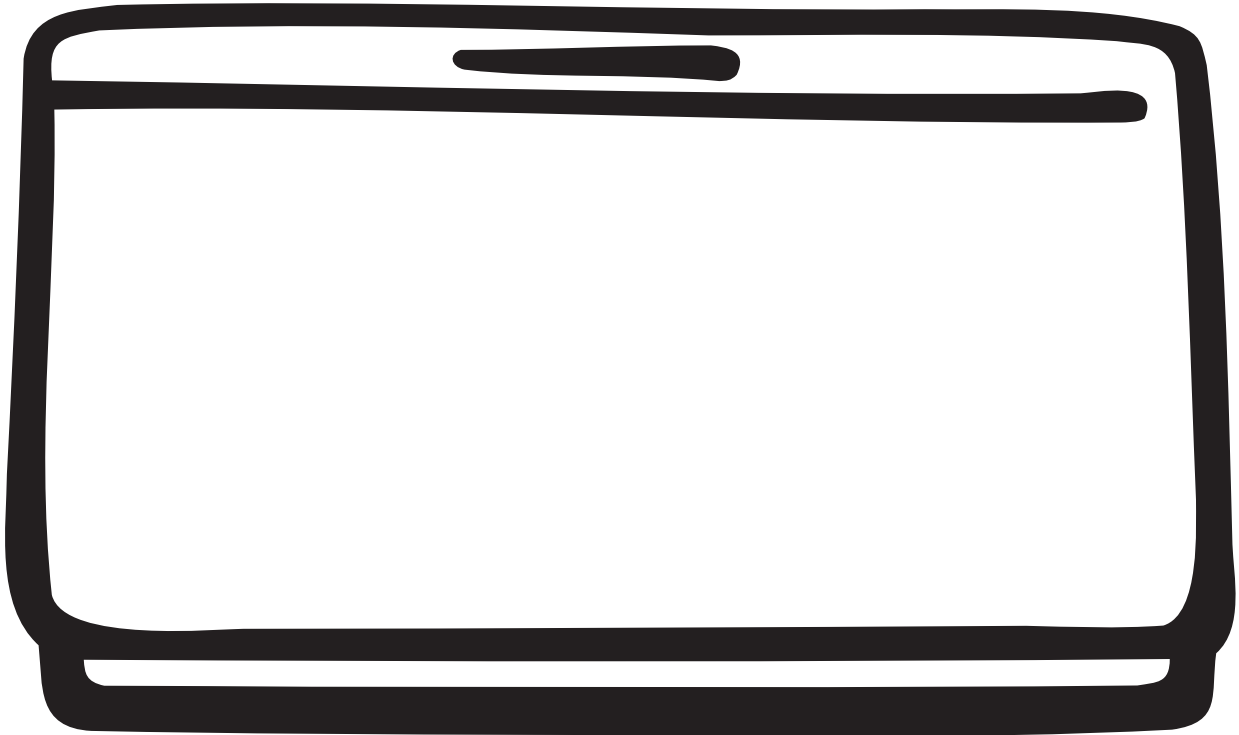

ECM 1957 ECM 2257 ECM 3057 ECM 3857

GB

820 41 72 30

Important Safety Information



These warnings are provided in the interests of your safety. Ensure that you understand them all before installing or using this appliance. Your safety is of paramount importance. If you are unsure about any of the meanings or these warnings contact the Customer Care Department.

Prior to Installation

Check the appliance for transport damage. Under no circumstances should a damaged appliance be installed. In the event of damage please contact your retailer.

Installation

- This appliance is heavy. Care should be taken when moving it.
- It is dangerous to alter the specifications or attempt to modify this product in any way.
- Ensure that the appliance does not stand on the electrical supply cable. If the supply cable is damaged, it must be replaced by a cable available from your local Service Force Centre.
- Any electrical work required to install this appliance should be carried out by a qualified electrician or competent person.
- Parts which heat up should not be exposed. Whenever possible, the back of the appliance should be close to a wall, but leaving the required distance for ventilation, as stated in the installation instructions.
- The appliance should be left for 2 hours after installation before it is turned on, in order to allow the refrigerant to settle.

Child Safety

- Do not allow children to tamper with the controls or play with the product.
- There is a risk of suffocation! Keep packaging material away from children!

During Use

- This appliance is designed for domestic use only, specifically for the storage of edible foodstuffs. It is not intended for commercial or industrial use.
- Containers with flammable gases or liquids can leak at low temperatures. Do not store any containers of flammable materials, such as spray cans, fire extinguisher refill cartridges etc. in the freezer.

- Frozen food should not be refrozen once it has thawed out.
- Do not place carbonated or fizzy drinks in the freezer compartment
- Ice lollies can cause 'frost/freezer burns' if consumed straight from the freezer
- Do not remove items from the freezer compartment if your hands are damp/wet, as this could cause skin abrasions or frost/freezer burns.
- Bottles and cans must not be placed in the freezer compartment they can burst when the contents freeze.
- Manufacturers' recommended storage times should be adhered to. Refer to relevant instructions.

Maintenance and Cleaning

- Before cleaning, always switch off the appliance and disconnect from the electrical supply.
- When unplugging always pull the plug from the mains socket, do not pull on the cable.

Servicing

- This product should be serviced by an authorised engineer and only genuine spare parts should be used.
- Under no circumstances should you attempt to repair the appliance yourself. Repairs carried out by inexperienced persons may cause injury or serious malfunctioning. Contact your local Service Force Centre.

Disposing of the Appliance

- When disposing of your appliance use an authorised disposal site. Check with your local Council or Environmental Health Office to see if there are facilities in your area to recycle the appliance.
- Make the appliance unusable by removing the plug and ensuring that any locks or catches are removed, to prevent young children being trapped inside.

Contents

Instructions for the User

Important Safety Information	2
Description of the Appliance	4
Control Panel	4
Digital temperature display	5
Temperature warning	5
Temperature adjustment	5
Freezing	6
Freezing Fresh Food	6
Frozen Food Storage	6
Thawing	7
Baskets	8
Hints and Tips	9
Normal Operating Sounds	9
Food Storage	9
Energy Saving Advice	9
In the Event of a Power Failure	9
Defrosting	10
Maintenance and Cleaning	11
Internal Cleaning	11
External Cleaning	11
When the Appliance is not in Use	11
To change the Light Bulb	11
Something not Working	12
Service and Spare Parts	13
Customer Care	12
Guarantee Conditions	14

Instructions for the installer

Technical Specifications	16
Installation	
Positioning	16
Electrical Connections	17

Description of the Appliance

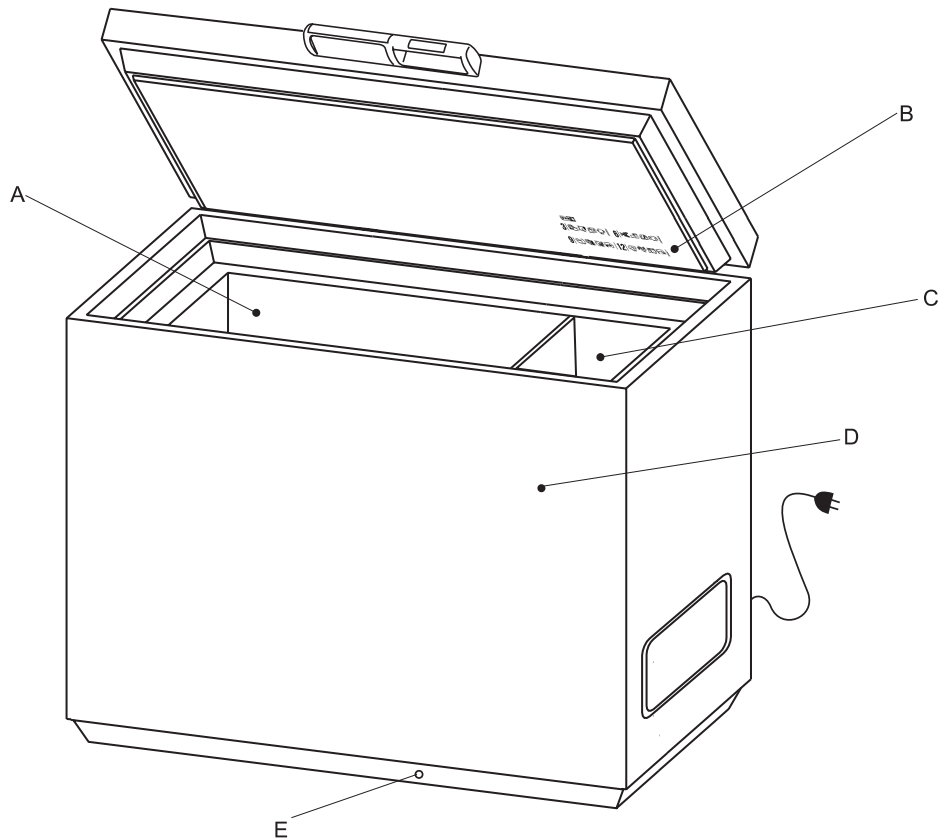

- A - Frozen food storage
- B - Freezer calendar (recommended storage times for frozen foods)
- C - Compartment for freezing fresh foods
- D - Dividing wall
- E - Defrost water drain

Control Panel

(various models)

1. Temperature controller knob and mains on pilot light (green)
2. FROSTMATIC button for the super-freeze function and FROSTMATIC pilot light (yellow)
3. WARNING OFF button (to switch off the warning buzzer) and warning pilot light (red)
4. Digital temperature display (not included with all models)

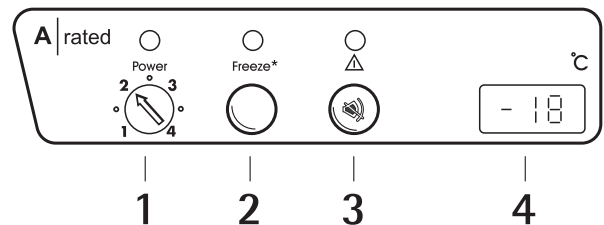

Digital temperature display

(not included with all models)

Some models have a digital temperature display integrated in the handle of the lid. In normal operation, it shows the temperature of the frozen products in centigrade (°C). There are however the following exceptions:

- After switching on the freezer "--" is shown briefly.
- If the temperature inside the freezer is higher than 0 °C, "+" appears.
- If the storage temperature cannot be measured due to a malfunction, "+" or "-36", appear and at the same time the warning buzzer and the red warning light indicate an alarm condition. (Also see section "Something Not Working").

i The temperature display indicates the temperature of the frozen food and therefore changes relatively slowly, if you put fresh goods in for example. If you leave the lid open for a long time, the temperature warning may respond, the temperature display may however remain unchanged. In this case there is no malfunction. Press the WARNING OFF button, to switch the warning buzzer off. The red warning light goes out automatically after a short time.

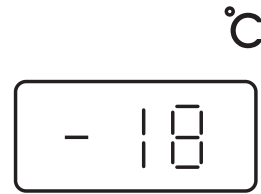

TEMPERATURE WARNING

If the temperature in the freezer is too high, the warning buzzer sounds and the red warning light flashes.

The warning buzzer and red warning light are triggered:

- if the storage temperature required has not yet been reached when starting the freezer; if the storage temperature is no longer maintained (malfunction);
- after inserting fresh foodstuffs in a greater quantity than permitted by the freezing capacity (see section on "Freezing");
- if the lid is left open too long.

👉 You can switch off the warning buzzer with the WARNING OFF button. The red warning light continues to flash until it is sufficiently cold again inside the freezer.

i The warning buzzer and red warning light are not triggered:

- if the power supply is interrupted;
- if the electronic thermostat is faulty.

TEMPERATURE ADJUSTMENT

A coin has to be used to turn the temperature control knob. This makes it more difficult to inadvertently adjust the temperature (child protection).

Position "1" means: warmest internal temperature

Position "4" means: coldest internal temperature

Recommended position: "2" or "3"

👉 Turn the temperature control knob to position "2" or "3" using a coin.

i The internal temperature will be affected by the following:

- ambient temperature
- quantity of food stored;
- frequent or prolonged opening of the lid.

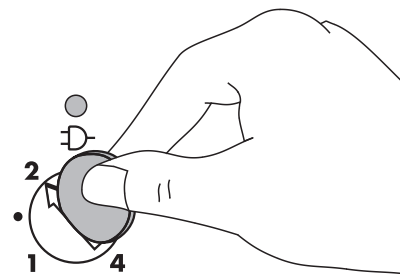

 Therefore regularly monitor that the optimal storage temperature of -18 °C or colder is maintained, either using the thermometer or the digital temperature display depending on which model you have.

 If necessary, adjust the temperature setting, until the thermometer or the digital temperature display shows -18 °C or colder.

 From a food safety point of view, -18 °C is considered a sufficiently cold storage temperature.





FREEZING

Tip: To freeze fresh foods use the small freezing compartment on the right of the dividing partition (also see section on "Interior accessories(dividing partition)"). This enables you to separate already frozen foods from fresh foods. Always make sure already frozen goods cannot defrost by coming into contact with fresh products. If the freezing compartment is too small you can freeze part of the products in the large storage section on the left of the dividing partition.

Attention!

- Before freezing food the temperature in the freezer must be -18 °C or colder.
- Please observe indicated freezing capacity on the rating plate. The freezing capacity represents the maximum amount of fresh goods that can be frozen within 24 hours. If you freeze goods on several days, one after the other, freeze amounts equal to 2/3 to 3/4 of the capacity indicated on the rating plate.
- Thawed foods which have not been processed further (cooked into meals) must not under any circumstances be frozen a second time.

 To make use of the maximum freezing capacity press the FROSTMATIC button 24 hours prior to freezing, or 4 to 6 hours for smaller quantities. Yellow display lights up.

 The FROSTMATIC button need not be pressed for freezing of small quantities of up to 3 kg.

 All foods must be packed air tight prior to freezing, so that they do not dry out or lose their flavour, and so that no flavour contamination of other frozen goods occurs.

Caution! Do not touch the frozen foods with wet hands. Hands can freeze to the goods.

 Place the packed food products into the freezer. Ensure they come into contact with the side walls. Unfrozen goods may not come into contact with already frozen goods, otherwise the frozen goods may start to thaw.

 If more products are to be frozen, keep fast freeze FROSTMATIC function switched on, if not switch it off about 24 hours after placing the food in the freezer. For smaller quantities, it can be switched off sooner. To do this, press the FROSTMATIC button again. The yellow FROSTMATIC display goes out.

 If you do not switch off the fast freeze process with the FROSTMATIC switch it switches itself off automatically after 48 hours.

Tips:

- The following are suited for the packaging of frozen goods:
 - freezer bags and polyethylene wraps;
 - special cans for frozen goods;
 - extra-thick aluminium foil
- The following are suitable for closing bags and foil: plastic clips, rubber bands or adhesive tape.
- Before closing press out the air from the bags and foil, as air make the frozen products dry out more easily and wastes space.
- Make flat packages, because these freeze more quickly.
- Do not fill cans for frozen goods to the brim with liquid or paste-like goods, because liquids expand during freezing.

Note for inspection authorities:

Batch plans for the determination of freezing performance or warm-up time can be requested directly from the manufacturer.

It is important that fresh food placed in the freezer is frozen quickly and that the food already in the freezer is heated as little as possible.

Frozen Food Storage

When first starting the freezer or if the freezer has been out of use for some time, we advise you to run your appliance for at least 2 hours before storing frozen food.

Do not exceed the storage period indicated by the manufacturer.

Do not open the lid frequently or leave it open longer than is necessary.

Important

Do not put carbonated liquids in the freezer.

Ice lollies, if consumed immediately after removal from the freezer can cause a low temperature skin burn.

Do not remove items from the freezer if your hands are damp/wet, as this could cause skin abrasions or frost/freezer burns.

In the event of a power cut, do not open the lid. The food in the freezer will not be affected if the power cut is short and the freezer is full. Should the food begin to thaw it must be consumed quickly and must not be re-frozen.

(See Hints and Tips)

Thawing

Frozen food, prior to being used, can be thawed in the fridge or at room temperature, depending on the time available. Small food items may even be cooked from frozen, in this case cooking will take longer.

Any frozen food which is allowed to thaw accidentally should either be eaten as soon as possible, or thrown away. Alternatively, if the food is uncooked and has not been completely defrosted it can be cooked and then refrozen.

 ***Defrosted cooked food must never be refrozen.***

Baskets

The baskets are designed for the storage of food which has already been frozen. The handles can be placed in two positions, as shown.

The baskets can either be placed inside the freezer or hung on the edge of the casing.

The following spare parts can be ordered from your local Service force Centre. Please note that 2 handles must be ordered for each basket.

„A” Basket	291263000/1
„B” Basket	291263001/5
Handle	291340004/6 (2 required).

The following illustrations show how many baskets can be placed in various freezer models.

The number above each illustration shows the width of the freezer in millimetres.

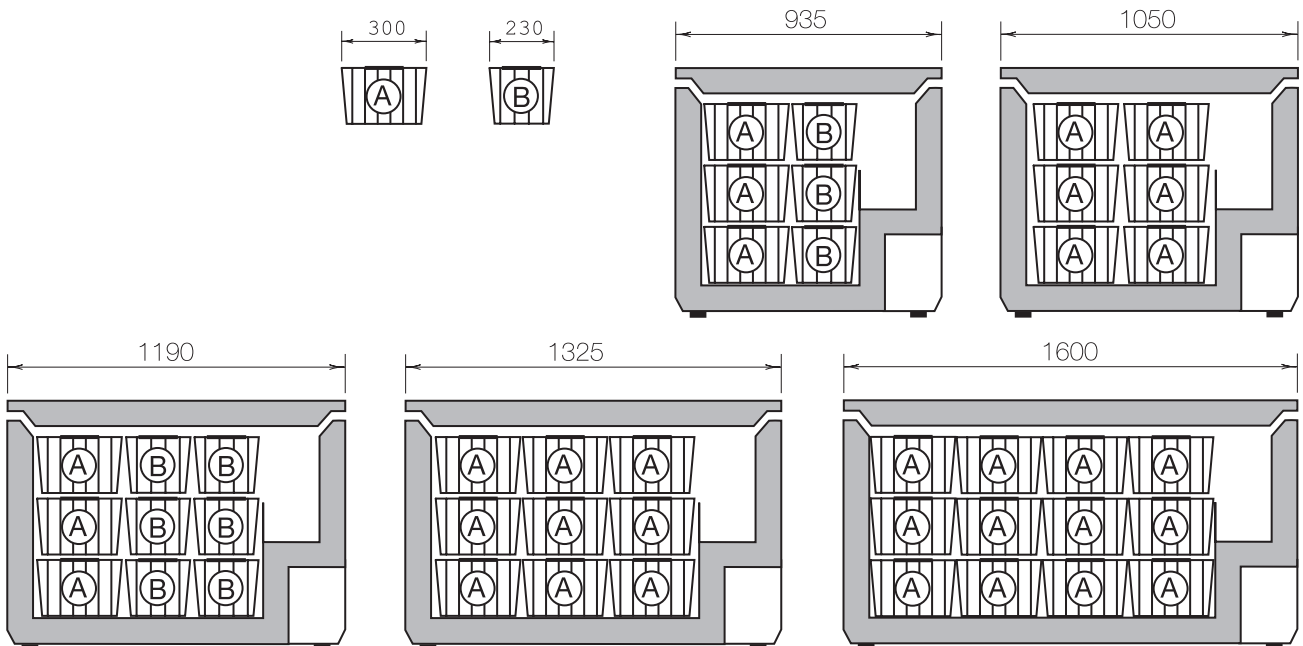
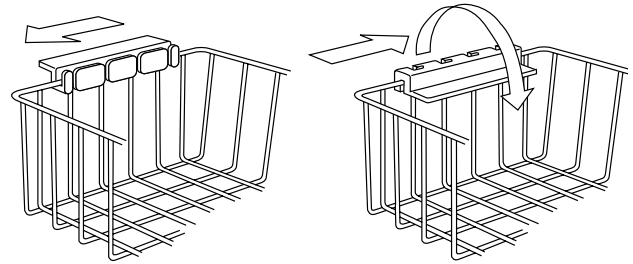

Hints & Tips

Normal Operating Sounds

- You may hear faint gurgling or bubbling sounds when the refrigerant is pumped through the coils or tubing.
- When the compressor is on, the refrigerant is being pumped round and you will hear a whirring sound or pulsating noise from the compressor.
- A thermostat controls the compressor and you will hear a faint 'click' when the thermostat cuts in and out.

Food Storage

To obtain the best performance from your freezer:

- Do not store warm food or evaporating liquid.
- Avoid buying frozen food if you cannot store it straight away. The use of an insulated container is advisable. When you arrive home, place the frozen food in the freezer immediately.
- Do not push food together too much, try to allow air to circulate around each item.
- Do not store food uncovered.
- Ensure that food placed in the freezer is dated and labelled and used in date order to ensure that food is consumed at its best.
- Lean food keeps better and longer than fatty food, salt reduces the storage time.
- Wrap the food in polythene or aluminium freezing bags or foil so that they adhere to the food and provide an airtight seal.
- Packaging which is swollen or has traces of refrozen water droplets on the pack could indicate that the product has not been kept at a suitable temperature and that it may have lost its original quality. Partially thawed food must not be refrozen, it must be consumed within 24 hours. Never exceed the storage times indicated by the manufacturer.

Energy Saving Advice

- Do not install the appliance close to sources of heat, such as a boiler or radiator.
- Locate the appliance in a cool well ventilated room and make sure that the opening of the appliance is not obstructed.
- Avoid unnecessary frosting in the cabinet by packing all foodstuffs into airtight packages before placing them in the freezer.
- Food which is to be frozen (when cool) should be placed in the fridge before being transferred to the freezer.
- Try to avoid keeping the lid open for long periods or opening the lid too frequently as warm air will enter the cabinet and cause the compressor to switch on unnecessarily often.
- Ensure there are no obstructions preventing the lid from closing properly.

In the Event of a Power Failure

If there is a power failure during the storage of frozen foods, keep the lid closed. If the temperature within your freezer should rise, do not refreeze the food without checking its condition. The following guidelines should assist you:

Ice Cream: Once thawed should be discarded.

Fruits & Vegetables: If soft should be cooked and used up.

Breads & Cakes: Can be refrozen without danger.

Shellfish: Should be refrigerated and used up quickly.

Cooked Dishes: i.e. casseroles should be refrigerated and used up.

Large Pieces of Meat: Can be refrozen providing there are still ice crystals remaining within them.

Small Joints: Should be cooked and can then be refrozen as cooked dishes.

Chicken: Should also be cooked and refrozen as a fresh dish.

Defrosting

The freezer compartment will become progressively covered with frost. This should be removed with the special plastic scraper provided, whenever the thickness of frost exceeds ¼".

During this operation it is not necessary to switch off the power supply or to remove the foodstuffs.

However, when the ice becomes very thick on the inner liner, complete defrosting should be carried out and it is advisable to perform this operation when the appliance is empty.

 To carry out complete defrosting:

1. Disconnect the appliance from the electrical supply.
2. Remove any stored food, wrap in several layers of newspaper and store in a cool place.
3. Leave the lid open.
4. Remove the plug from the drip water drain.
5. To accelerate the defrosting process place a bowl of hot (not boiling) water inside the freezer and close the lid.
6. The defrost water can be collected in a bowl, as shown.
7. When defrosting is completed, dry the interior thoroughly and replace the plug on the drip water drain.
8. Turn the thermostat control back to a medium setting and leave to run for at least 2 hours.
9. Replace the previously removed food.

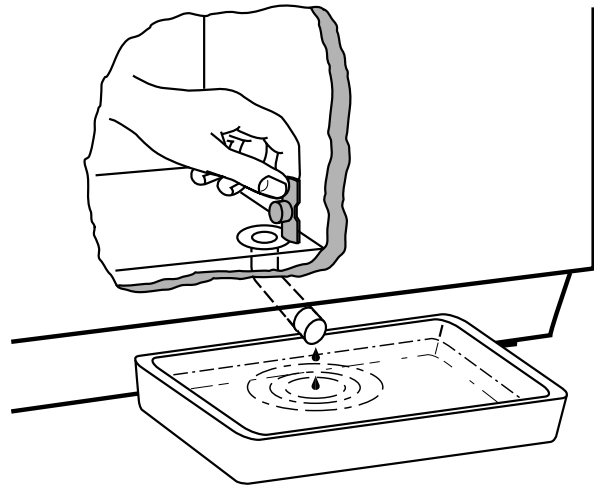

Important

A temperature rise of the frozen food packs during defrosting may shorten their safe storage life.

Never use sharp metal tools to scrape off frost from the evaporator as this could damage the appliance beyond repair.

Maintenance and Cleaning



Before any maintenance or cleaning is carried out you must DISCONNECT the appliance from the electricity supply

Internal Cleaning

Clean the inside and accessories with warm water and bicarbonate of soda (5ml to 0.5 litre of water).

Rinse and dry thoroughly.



NEVER use detergents, abrasive powders, highly perfumed cleaning products or wax polishes to clean the interior as these will damage the surface and leave a strong odour.



To Change the Light Bulb

(Not a standard accessory for all models)

1. Disconnect the appliance from the electrical supply.
2. Unscrew the bulb.
3. Replace with a new bulb (max. 15W)
4. Reconnect to the electrical supply.

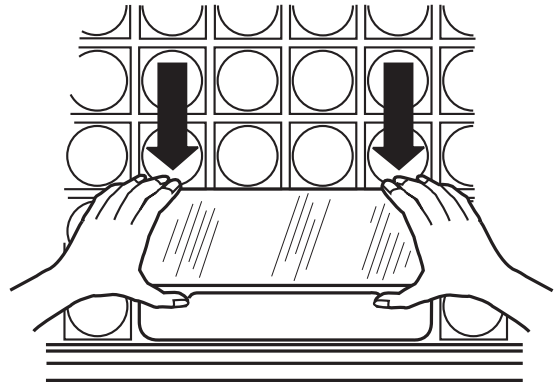

Spare bulbs are available from your local Electrolux Service Force Centre.

External Cleaning

Wash the outer cabinet with warm soapy water.

When the Appliance is not in Use

When the appliance is not in use for long periods, disconnect from the electricity supply, empty all foods and clean the appliance, leaving the lid open to prevent unpleasant smells.

Something not Working

If the appliance is not working correctly, please carry out the following checks before contacting your local Electrolux Service Force Centre

SYMPTOM	SOLUTION
No power to the appliance	<ul style="list-style-type: none"> • Check there is power at the socket • Check there is not a power cut by checking the household lights. • Check the mains fuse has not blown.
The temperature in the freezer is too high	<ul style="list-style-type: none"> • Check the thermostat is turned to the correct setting relevant to ambient conditions. • Check the ambient temperature is within the appliance's operating limits of 10° 32°C.
The freezer lid will not open	<ul style="list-style-type: none"> • Has the lid just been opened? If so leave for a few minutes to allow the air pressure to equalise.
Excessive frost and ice has built up	<ul style="list-style-type: none"> • Adjust the thermostat to give correct temperature control. See 'Temperature Control'. • Large quantities of food have recently been placed in the cabinet/and or the lid is frequently opened. • Check that air ventilation is not obstructed. Ensure the lid has not been left open. • Check that nothing is preventing the lid from closing. • Is the lid gasket intact and clean? • Has advised periodic defrosting been carried out.
Noise	<ul style="list-style-type: none"> • Refer to 'Normal Operating Sounds'

If after all these checks your appliance still does not operate correctly, contact your local Electrolux Service Force Centre.

Please note that it will be necessary to provide proof of purchase for any in-guarantee service calls.

In-guarantee customers should ensure that the above checks have been made, as the engineer will make a charge if the fault is not a mechanical or electrical breakdown.

Service and Spare Parts

In the event of your appliance requiring service, or if you wish to purchase spare parts, please contact your local Electrolux Service Force Centre by telephoning:

0870 5 929929

Your telephone call will be automatically routed to the Service Force Centre covering your post code area. For the address of your local Service Force Centre and further information about Service Force please visit the website at www.serviceforce.co.uk.

Customer Care Department

For general enquiries concerning your Electrolux appliance or for further information on Electrolux products, you are invited to contact our Customer Care Department by letter or telephone at the address below or visit the website at www.electrolux.co.uk:

Customer Care Department
Electrolux
55-77 High Street
Slough
Berkshire
SL1 1DZ

Tel: 08705 950 950*

* calls to this number may be recorded for training purposes

Guarantee Conditions

We, Electrolux undertake that if within 12 months of the date of the purchase this Electrolux appliance or any part thereof is proved to be defective by reason only of faulty workmanship or materials, the company will, at our option repair or replace the same FREE OF CHARGE for labour, materials or carriage on condition that:

- The appliance has been correctly installed and used only on the electrical supply stated on the rating plate.
- The appliance has been used for normal domestic purposes only, and in accordance with the manufacturer's instructions.
- The appliance has not been serviced, maintained, repaired, taken apart or tampered with by any person not authorised by us.
- All service work under this guarantee must be undertaken by a Electrolux Service Force Centre.
- Any appliance or defective part replaced shall become the Company's property.

Home visits are made between **8.30am** and **5.30pm Monday to Friday**. Visits may be available outside these hours in which case a premium will be charged.

EXCLUSIONS

This Guarantee does not cover:

Damage or calls resulting from transportation, improper use or neglect, the replacement of any light bulbs or removable parts of glass or plastic.

- Costs incurred for calls to put right an appliance improperly installed or calls to appliances outside the United Kingdom.
- Appliances found to be in use within a commercial environment, plus those which are the subject of rental agreements.
- Products of Electrolux manufacture which are not marked by Electrolux.

This guarantee is in addition to your statutory and legal rights.

ELECTROLUX EUROPEAN GUARANTEE

If you should move to another country within Europe then your guarantee moves with you to your new home subject to the following qualifications:

- The guarantee starts from the date you first purchased your product.
- The guarantee is for the same period and to the same extent for labour and parts as exists in the new country of use for this brand or range of products.
- This guarantee relates to you and cannot be transferred to another user.
- Your new home is within the European Community (EC) or European Free Trade Area
- The product is installed and used in accordance with our instructions and is only used domestically, i.e. a normal household.
- The product is installed taking into account regulations in your new country.

Before you move please contact your nearest Customer Care Centre, list below, to give them details of your new home. They will then ensure that the local Service Organisation is aware of your move and able to look after you and your appliances.

France	Senlis	+33 (0)3 44 62 22 22
Germany	Nuremberg	+49 (0)911 323 2600
Italy	Pordenone	+39 (0)1678 47053
Sweden	Stockholm	+46 (0)20 78 77 55
UK	Slough	+44 (0)1753 219 898

Technical Specifications

Model		ECM 1957	ECM 2257	ECM 3057	ECM 3857		
Volume (gross)	litres	189	221	299	378		
Volume (net)	litres	184	216	292	368		
Height without/with roller	cm	87,6/88,3	87,6/88,3	87,6/88,3	87,6/88,3		
Width	cm	93,5	105	132,5	160		
Depth	cm	66,5	66,5	66,5	66,5		
Weight	kg	49	52	59	68		
Energy consumpt./24h	kWh	0,53	0,58	0,69	0,80		
Freezing capacity	kg/24h	23	24	28	29		
Hold-over time	hours	43	46	49	55		
Rated power	W	75	80	120	140		

Installation

Positioning

- Place the freezer horizontally on a firm surface, resting on all four wheels. Use a wooden block or similar object to compensate for any bumps/holes in the floor's surface.
- The room should be dry and adequately ventilated.
- If the room temperature exceeds 32°C, or falls below freezing point, the freezer will not function as it should.
- Do not place the freezer close to sources of heat, radiators, chimneys, etc. and do not place the freezer in direct sunlight.
- If the freezer has been handled standing on end, it should be allowed to stand in the normal position for about 12 hours before switching it on.
- Ensure that the appliance is installed where it is easily accessible for the engineer in the event of a breakdown.

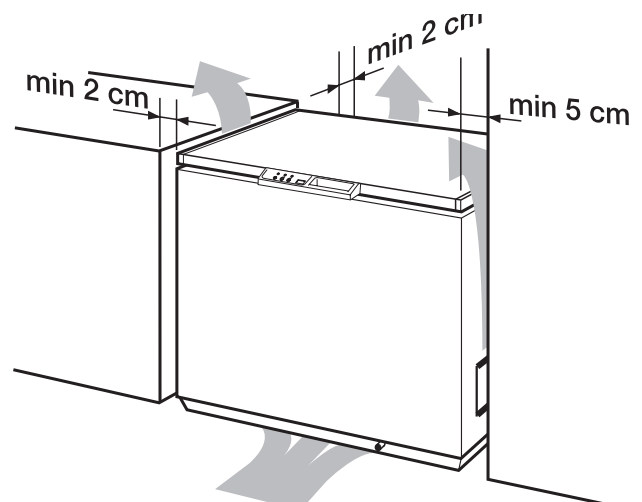

Electrical Connection



Any electrical work required to install this appliance should be carried out by a qualified electrician or competent person.

This appliance must be earthed.

The manufacturer declines any liability should these safety measures not be observed.

Electrical Requirements

Before switching on, make sure the electricity supply voltage is the same as that indicated on the appliance rating plate.

The appliance is supplied with a 13amp plug fitted. In the event of having to change the fuse in the plug supplied, a 13amp ASTA approved (BS1362) fuse must be used. Should the plug need to be replaced for any reason. The wires in the mains lead are coloured in accordance with the following code:

Green and Yellow:	Earth
Blue:	Neutral
Brown:	Live

The wire coloured green and yellow must be connected to the terminal marked with the letter "E" or by the earth symbol  or coloured green and yellow.

The wire coloured blue must be connected to the terminal "N" or coloured black.

The wire coloured brown must be connected to the terminal marked "L" or coloured red.

Upon completion there must be no cut, or stray strands of wire present and the cord clamp must be secure over the outer sheath.

