



**Service Manual for the Lang Models:
EHS-AP, EHS-C, EHS-PP, EHS-PT, & EHS-T**

TABLE OF CONTENTS

<u>CHAPTER</u>	<u>PAGE</u>
1. TABLE OF CONTENTS.....	2
2. READ FIRST.....	3
3. EQUIPMENT DESCRIPTION	5
4. INSTALLATION	7
5. START-UP	8
6. CONTROL PANEL LAYOUT	9
7. PROGRAMMING TERMS	14
8. PROGRAMMING	15
9. GENERAL OPERATION.....	24
10. TYPICAL OPERATION	26
11. SEQUENCE OF OPERATION.....	28
12. TROUBLESHOOTING	31
13. TECHNICAL DATA	41
14. WIRING DIAGRAMS	47
15. PARTS LIST	54

<u>CAUTION</u>	THE UNIT IS EXTREMELY HEAVY. FOR SAFE HANDLING, INSTALLER SHOULD OBTAIN HELP AS NEEDED, OR EMPLOY APPROPRIATE MATERIALS HANDLING EQUIPMENT (SUCH AS A FORKLIFT, DOLLY, OR PALLET JACK) TO REMOVE THE UNIT FROM THE SKID AND MOVE IT TO THE PLACE OF INSTALLATION.
<u>CAUTION</u>	ANY STAND, COUNTER OR OTHER DEVICE ON WHICH OVEN WILL BE LOCATED MUST BE DESIGNED TO SUPPORT THE WEIGHT OF THE OVEN.
<u>CAUTION</u>	SHIPPING STRAPS ARE UNDER TENSION AND CAN SNAP BACK WHEN CUT.
<u>DANGER</u>	THIS APPLIANCE MUST BE GROUNDED AT THE TERMINAL PROVIDED. FAILURE TO GROUND THE APPLIANCE COULD RESULT IN ELECTROCUTION AND DEATH.
<u>WARNING</u>	INSTALLATION OF THE UNIT MUST BE DONE BY PERSONNEL QUALIFIED TO WORK WITH ELECTRICITY AND PLUMBING. IMPROPER INSTALLATION CAN CAUSE INJURY TO PERSONNEL AND/OR DAMAGE TO EQUIPMENT. UNIT MUST BE INSTALLED IN ACCORDANCE WITH ALL APPLICABLE CODES.
<u>NOTICE</u>	The data plate is on the back side of the oven above the power cord. The oven voltage, wattage, serial number, wire size, and clearance specifications are on the data plate. This information should be carefully read and understood before proceeding with the installation.
<u>NOTICE</u>	The installation of any components such as a vent hood, grease extractors, fire extinguisher systems, must conform to their applicable National, State and locally recognized installation standards.
<u>NOTICE</u>	During the first few hours of operation you may notice a small amount of smoke coming from the oven, and a faint odor from the smoke. This is normal for a new oven and will disappear after the first few hours of use.
<u>CAUTION</u>	ALWAYS KEEP THE AREA NEAR THE APPLIANCE FREE FROM COMBUSTIBLE MATERIALS.
<u>CAUTION</u>	KEEP FLOOR IN FRONT OF EQUIPMENT CLEAN AND DRY. IF SPILLS OCCUR, CLEAN IMMEDIATELY, TO AVOID THE DANGER OF SLIPS OR FALLS.
<u>WARNING</u>	KEEP WATER AND SOLUTIONS OUT OF CONTROLS. NEVER SPRAY OR HOSE CONTROL CONSOLE, ELECTRICAL CONNECTIONS, ETC.
<u>CAUTION</u>	MOST CLEANERS ARE HARMFUL TO THE SKIN, EYES, MUCOUS MEMBRANES AND CLOTHING. PRECAUTIONS SHOULD BE TAKEN TO WEAR RUBBER GLOVES, GOGGLES OR FACE SHIELD AND PROTECTIVE CLOTHING. CAREFULLY READ THE WARNING AND FOLLOW THE DIRECTIONS ON THE LABEL OF THE CLEANER TO BE USED.
<u>NOTICE</u>	Never leave a chlorine sanitizer in contact with stainless steel surfaces longer than 10 minutes. Longer contact can cause corrosion.



NOTICE

Service on this, or any other, LANG appliance must be performed by qualified personnel only. Consult your authorized service station directory or call the factory at 1-800-224-LANG (5264), or WWW.LANGWORLD.COM For the service station nearest you.



WARNING

BOTH HIGH AND LOW VOLTAGES ARE PRESENT INSIDE THIS APPLIANCE WHEN THE UNIT IS PLUGGED/WIRED INTO A LIVE RECEPTACLE. BEFORE REPLACING ANY PARTS, DISCONNECT THE UNIT FROM THE ELECTRIC POWER SUPPLY.



NOTICE

If an item on the list is followed by an asterisk (*), the work should be done by a factory authorized service representative.



CAUTION

USE OF ANY REPLACEMENT PARTS OTHER THAN THOSE SUPPLIED BY LANG OR THEIR AUTHORIZED DISTRIBUTORS CAN CAUSE BODILY INJURY TO THE OPERATOR AND DAMAGE TO THE EQUIPMENT AND WILL VOID ALL WARRANTIES.



EQUIPMENT DESCRIPTION

Lang Model: EHS Electric Half Size Convention Oven

EXTERIOR

- The oven exterior dimensions are 30” (76.2 cm) Wide, 25” (63.5 cm) High, 26.5” (67.31 cm) Deep. The Top, Front, Back, and Sides are constructed of stainless steel with an aluminized bottom.
- The oven door comes standard with a window.
- The door handle is constructed of Polycarbonate.
- The oven cavity is insulated with high temperature insulation for efficiency and reduced heat loss.

INTERIOR

- The oven cavity dimensions are 15” (38.1 cm) Wide, 20” (50.84 cm) High, 21” (53.38 cm) Deep.
- The oven is designed for five shelves and comes with five Chrome Plated Racks.
- The interior of the oven is constructed of stainless steel.

OPERATION

- The EHS oven is a forced air convection oven with a vented oven cavity.
- The air is driven by a 1/3 HP fan motor.

CONTROLS

- The EHS is available either with the Lang Mfg; Accu-Temp (EHS-T) controls, Accu-Plus (EHS-AP) controls, “Purple” Computer (EHS-C) controls, “Purple-Plus” Computer (EHS-PP) controls, and “Platinum” Computer (EHS-PT) controls which include:
 - **EHS-T**
 - Easy to use manual control knobs.
 - Pulse and two speed fan.
 - **EHS-AP**
 - Easy to use manual control knobs.
 - Pulse and two speed fan.
 - Solid State temperature sensing and controls.
 - **EHS-C**
 - Complete Computerized Controls with a Manual Override system.
 - Programmable up to 10 products with four “tiers” for each program.
 - Independent Shelf Timers for each Shelf.
 - Load Control through use of Cooking Curves.
 - Shelf Compensation Timing for uniform baking.
 - Single speed fan.
 - **EHS-PP**
 - The Purple Plus offer the same great one touch system of the Purple, coupled with the advanced backing capabilities of the new Platinum.

EQUIPMENT DESCRIPTION CONT'D

- **EHS-PT**

- Icon-driven (touch) panel allows for easy operation, also includes a manual override system.
- Day-Part Memory capabilities allow operators to “recall” the last daily selections automatically.
- Programmable up to 99 products, advanced baking capabilities include: a 12:59:59 timer with ten “tiers”
- Independent Shelf Timer for each Shelf.
- Load Control through use of Cooking Curves.
- Shelf Compensation Timing for uniform baking.
- Dual speed fan.

RECEIVING THE OVEN

Upon receipt, check for freight damage, both visible and concealed. Visible damage should be noted on the freight bill at the time of delivery and signed by the carrier's agent.

Concealed loss or damage means loss or damage, which does not become apparent until the merchandise has been unpacked.

If concealed loss or damage is discovered upon unpacking, make a written request for inspection by the carrier's agent within 15 days of delivery. All packing material should be kept for inspection.

Do not return damaged merchandise to Lang Manufacturing Company. File your claim with the carrier.

Prior to un-crating, move the oven as near its intended location as practical. The crating will help protect the unit from the physical damage normally associated with moving it through hallways and doorways.

ELECTRICAL CONNECTION

The electrical connection must be made in accordance with local codes or in the absence of local codes with NFPA No. 70 latest edition (in Canada use: CSA STD. C22.1).

The electrical service entrance is provided by a 1 1/4 inch knock-out at the oven back directly behind the control compartment. Grounding lugs are provided at the rear service entrance.

INSTALLING THE LEGS

Legs are available for single, double, and counter top installations. Single deck installations require a 28-inch leg, double deck installations require a 16-inch leg, and counter top installations require a 4-inch leg.

To install the 28-inch legs, place some cardboard on the floor and gently tip the oven onto its back. Fasten two legs to the oven's front. Lift the oven onto its front legs and block the back up using one of the 28-inch legs set upside down in the center rear of the oven body. Install the last 28-inch leg onto the oven body on the control side rear. Gently lift the oven rear, remove the leg set to support the oven center and install it on the last rear corner.

To install the 16-inch legs follow the same instructions as the 28-inch legs.

To install the 4-inch legs, place some cardboard on the floor and gently tip the oven onto its back. Fasten the four 4-inch legs into the threaded holes provided on the bottom of the convection oven. Gently lift the oven onto the legs.

STACKING THE OVENS

Remove all the plug buttons from the top of the lower oven.

Remove the stacking kit from the oven compartment of one oven and install the 1 1/4 inch plastic bushing into the top of the lower oven.

Tip the top oven backwards and install two pins into the front leg holes of the top oven.

Lift the top oven and gently set on top of the lower oven so that the studs nest into the holes of the lower oven.

EHS-C/ EHS-PP/ EHS-PT

Convection Oven Start-Up

1) Verify connections at plug and terminal block

2) Incoming Volt - Single Phase L1-L2 _____
Three Phase L1-L2 _____ L2-L3 _____ L3-L1 _____

3) Amp draw L1 _____
L2 _____
L3 _____

4) Motor amp draw _____

5) Are programs correct? Yes No

6) Verify actual temperature at 350 °F _____ °F.

Note:

Install thermocouple wire in center of oven cavity.

Let oven cycle off and on 3 times before recording temperature.

Set oven temperature for 350 °F

Model # _____ Date _____ Serial # _____

Store # _____ Tech Name _____

Contact _____ Company _____

Store Phone # _____ Service Company Phone # _____

Address _____

CONTROL PANEL LAYOUT EHS-T

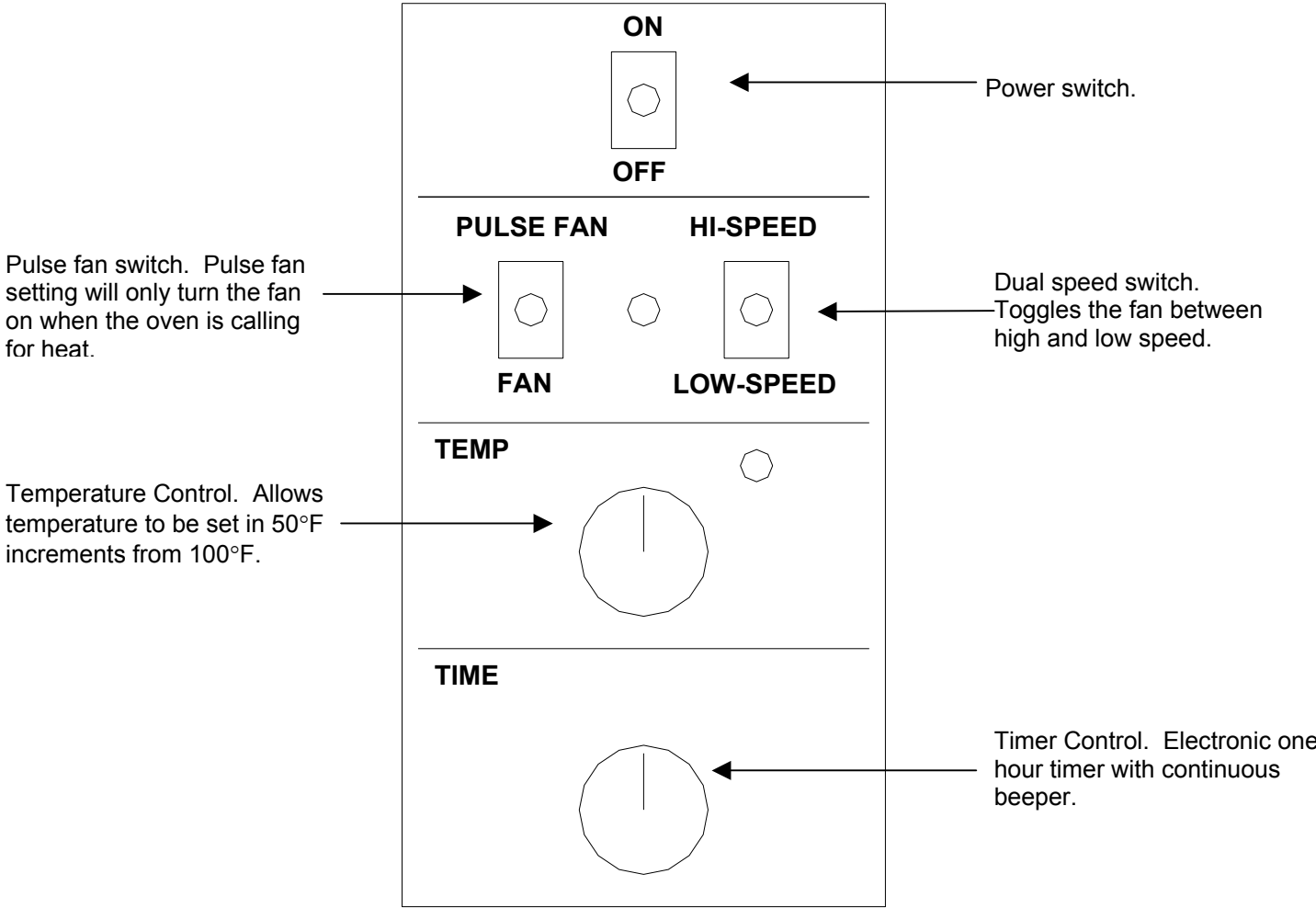

CONTROL PANEL LAYOUT EHS-AP

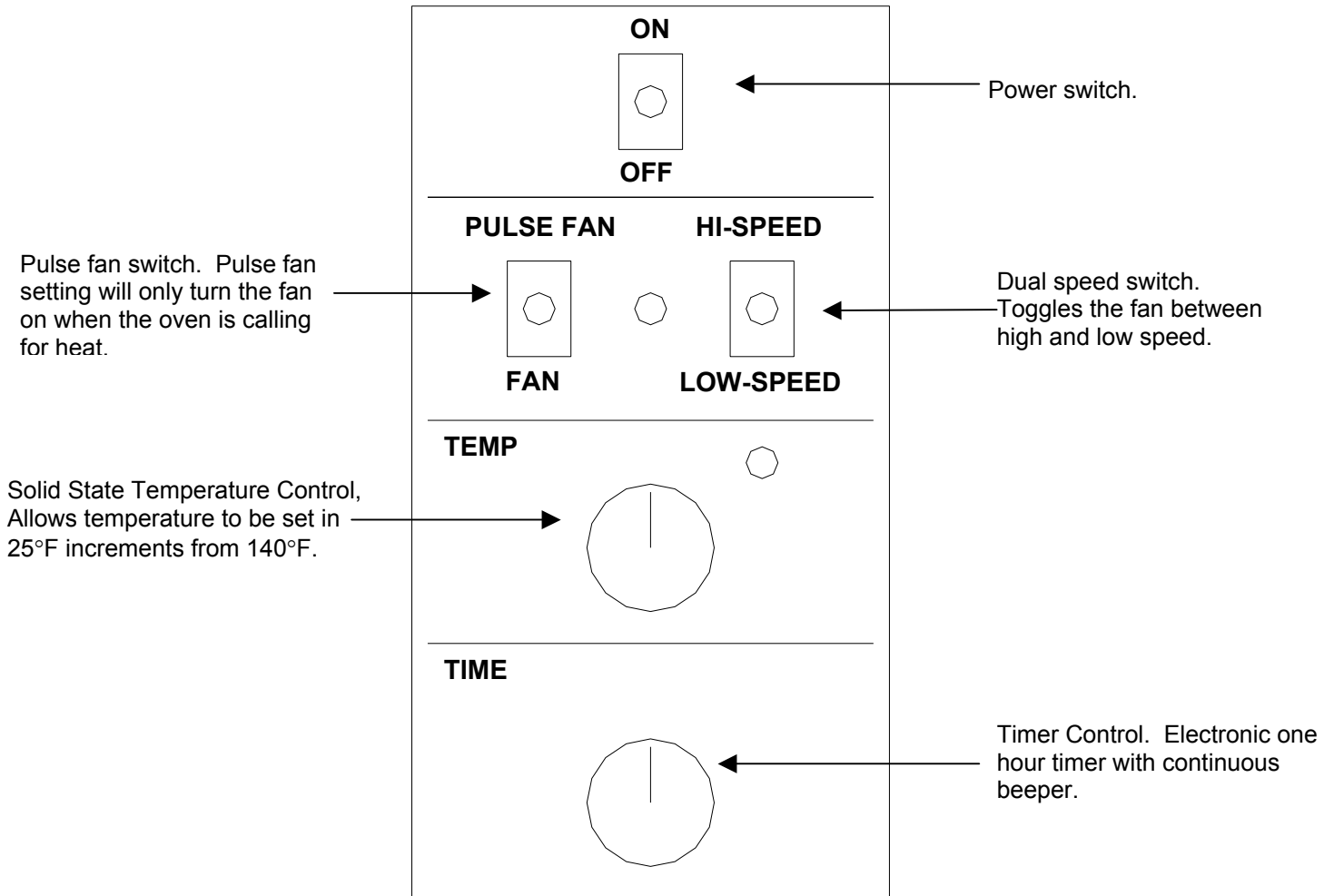

CONTROL PANEL LAYOUT EHS-C

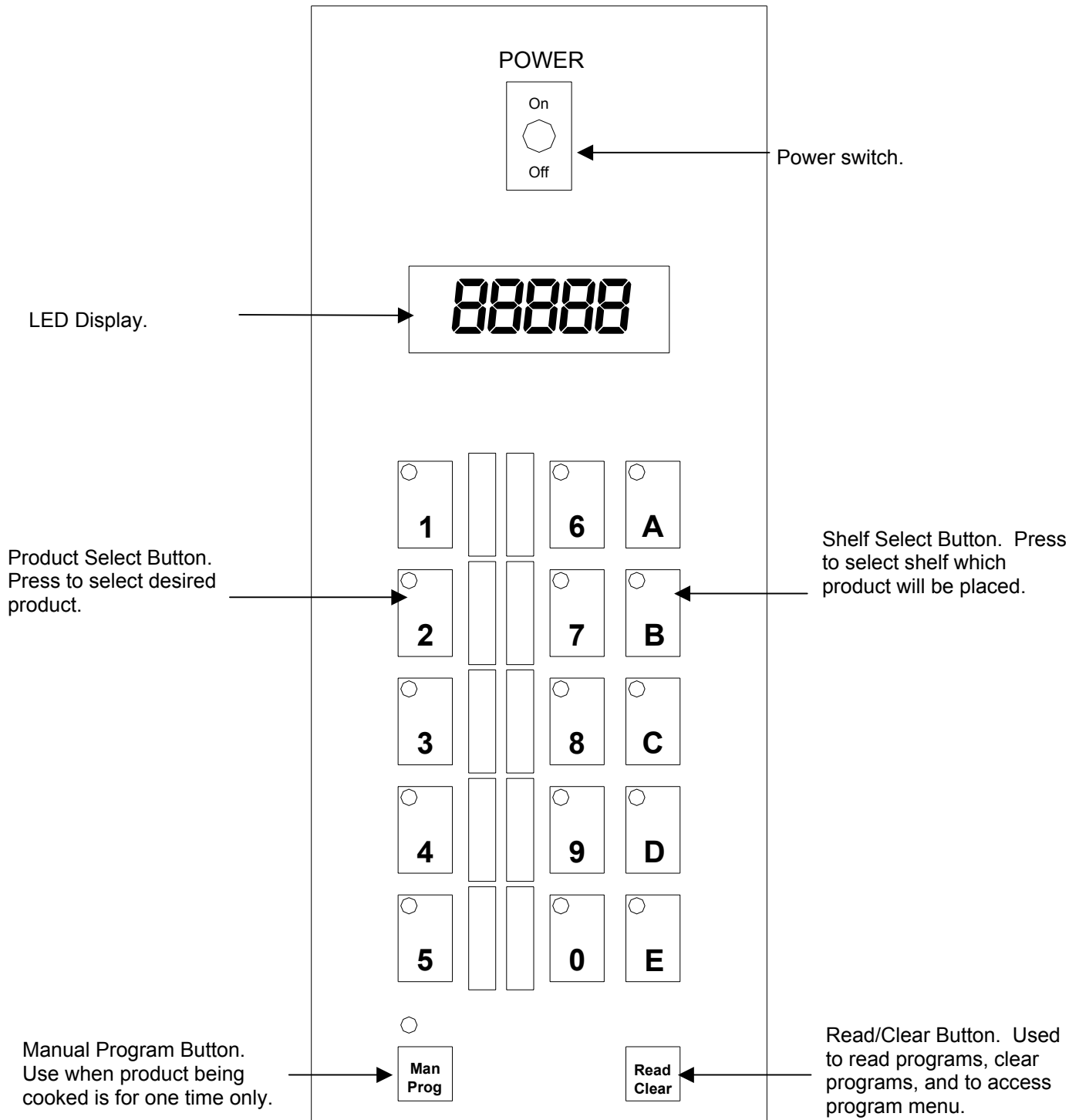

CONTROL PANEL LAYOUT EHS-PP

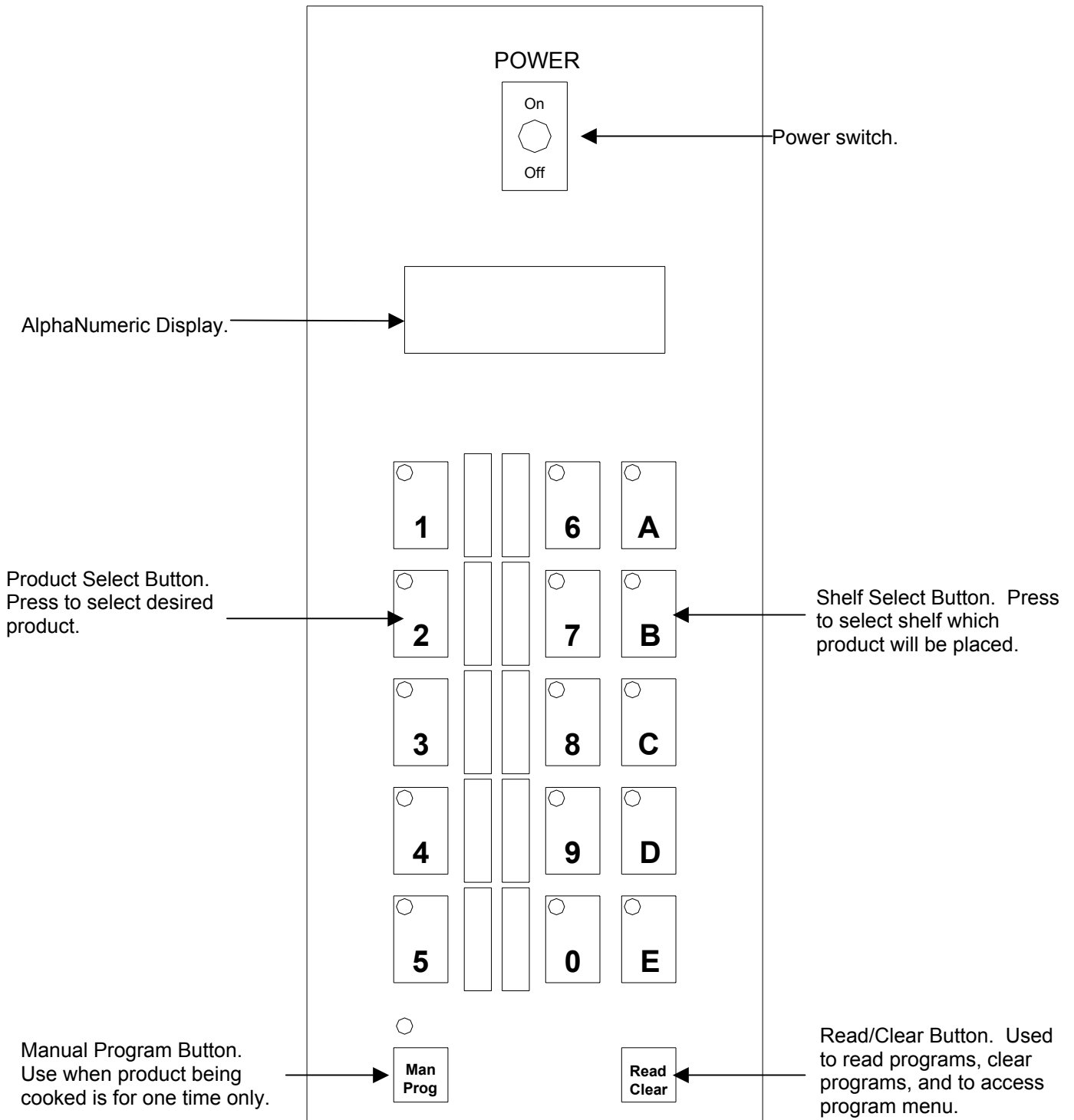

CONTROL PANEL LAYOUT EHS-PT

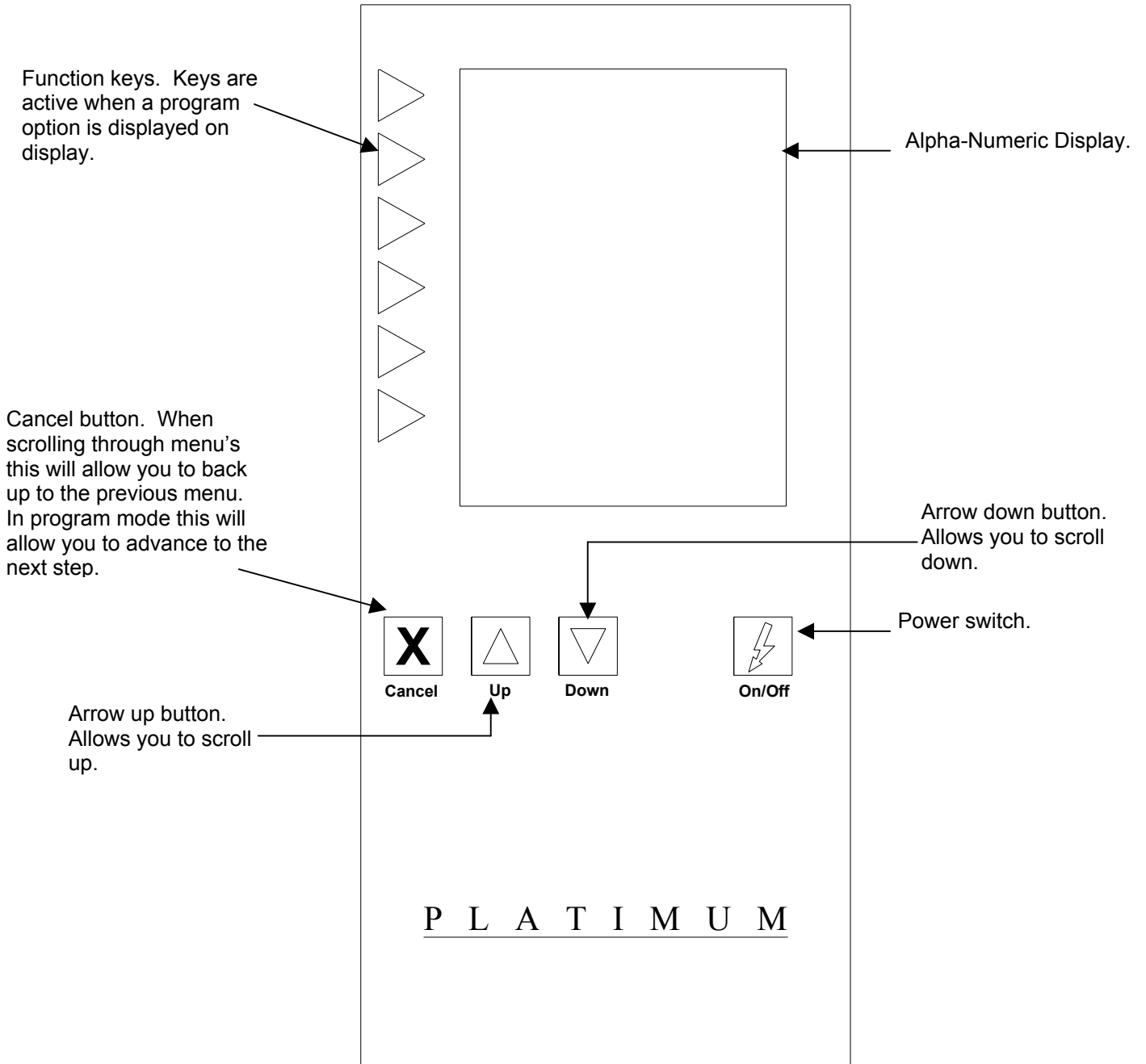

Control Panel Buttons

- 1 - 0** Product Buttons. These are the buttons where the product programs are stored. Pressing a Product Button will heat the oven to the programmed temperature.
- A - E** Shelf Buttons. The control is capable of timing each shelf individually. Pressing a Product Button then a Shelf Button will start the countdown timer.
- Man Prog** The MANUAL PROGRAM button allows the operator to enter a temporary product program without being required to input the programming code. The temporary program is erased when the oven is turned off or when a new program is entered. Time and temperature are the only parameters that can be entered in the Manual Program mode.
- READ/CLEAR** The READ/CLEAR button has several functions.
- It is always the first button pressed when entering programming codes.
 - Pressing it twice then pressing a Product Button will "read-back" the program in that product button.
 - Pressing and holding the button down until "88888" appears in the display will cancel the current mode of the control and return the display to "EntEr".
- Temp** When the Temperature Recall Button is pressed, the display will indicate the internal oven temperature. When released the display will revert to the previous readout.

Programming Terms

- COOKING CURVE** Cooking curve is a function of the computer that controls the cooking time. If the temperature of the oven is lower than the programmed temperature, the control will slow the timer down to compensate for the lower cooking temperature. Cooking Curves from 0 - no time adjustment to 7 - maximum adjustment are available. Cooking Curve 3 is the most commonly used. However, as a general rule the longer the cooking time the lower the cooking curve, the shorter the cooking time the higher the cooking curve.
- FAN FUNCTION** The convection fan has two programmable options. Fan On (Fan 1) runs the convection fan continuously. Fan Off (Fan 0) leaves the fan off until heat is called for by the control. In a convection oven, the fan must come On whenever the heat comes On. The convection fan can not be turned Off continuously.
- TIER** "Tiered" programming is the ability to change the cooking temperature or fan function during the cooking cycle. As an example, some products require the fan to be Off for the first half of the cooking cycle then turn On for the last half, Tier 1 would be programmed with the fan in the Off mode then Tier 2 would be fan On. The Tier lamps located below the display (labeled T1, T2, T3, and T4) will illuminate to indicate which Tier is being programmed or which Tier the program is in during the cooking cycle.

PROGRAMMING

ACTION	DISPLAY
Turn the power switch on. If the oven is already on, turn it off and then back on.	<i>EntEr</i>
Quickly enter access code “ R/C 1 6 2 7 3 8 ”. Do not hold the R/C button.	<i>Prod</i>
Select a Product number from 0-9 .	<i>St: 00</i>
Select amount of time that product should steam. If no steam is required press the shelf “ A ” button to advance to the next step. Note: If oven is not strapped for steam convection then this step will not be provided.	<i>000°F</i>
Select a Temperature from 150°F-450°F . NOTE: Entering “ 000 ” will erase the existing program.	<i>ccc-7</i>
Select the desired cooking curve from 0-7.	<i>FAno 12</i>
Enter a desired Fan setting. “ 0 ” (<i>noFAh</i>) Will make the fan pulse with the heat. “ 1 ” (<i>FAhnh 1</i>) Will make the fan run on high continuously. “ 2 ” (<i>FAhnhLo</i>) Will make the fan run on low continuously.	<i>00: 00: 00</i>
Enter the desired cooking time (hours:minutes:seconds)	<i>000°F</i>
The program is now entered for a single tier program, press the “ E ” button to continue programming other products. If the program is a multi tiered program continue by programming the next tiers. When complete press the “ E ” button.	<i>Prod</i>
When the programs have been completely entered press the “ R/C ” button to save and exit the programming cycle.	<i>EntEr</i>

EHS-C PROGRAMMING CODES

Below are codes, which will allow you to configure the display or aid in the operation, and troubleshooting of the oven.

The readout must display "**EntEr**" before the computer will accept any programming code. If the readout displays any other word, reset the computer by pressing and holding the "**R/C**" button until display reads "**BBBBBB**" then release. Display should now read "**EntEr**".

The control allows for a 3-second delay between each button push, if a delay of longer than 3 seconds has occurred, the programming code must be re-entered.

The instructions call for pressing exactly what is shown under "PRESS".

<u>CODE DESCRIPTION</u>	<u>PRESS</u>
<ul style="list-style-type: none"> • OPERATIONAL <ul style="list-style-type: none"> Recall time remaining on a shelf Cancel a shelf timer 	<ul style="list-style-type: none"> Shelf R/C, R/C, Shelf
<ul style="list-style-type: none"> • DISPLAY MODES <ul style="list-style-type: none"> Countdown timer display Shelf in use display Internal oven temperature display 	<ul style="list-style-type: none"> R/C,4,8,4,8,4,8 R/C,0,9,0,9,0,9 R/C,8,7,8,7,8,7
<ul style="list-style-type: none"> • PROGRAMMING <ul style="list-style-type: none"> Enter programming mode Recall an existing product program Erase a product program Model identification Fan Setting (HI or Both) Program download (Contact Factory) 	<ul style="list-style-type: none"> R/C,1,6,2,7,3,8 R/C, R/C, P (Product programmed) R/C,1,6,2,7,3,8 (P) (000) R/C, D,C,D,C,D,C R/C,E,D,C,B,A,1(high),2 (both) R/C, A, B, C, D, E, P
<ul style="list-style-type: none"> • MAINTENANCE <ul style="list-style-type: none"> Actual oven temperature Return to ENTER 	<ul style="list-style-type: none"> R/C,3,4,5,6,7,8 R/C
<ul style="list-style-type: none"> • SHELF COMPENSATION <ul style="list-style-type: none"> Enter shelf compensation mode Set shelf compensations Return to ENTER 	<ul style="list-style-type: none"> R/C, C, B, C, B, C, B (I.E.) A,2,3,A R/C

PROGRAMMING EHS-PP

ACTION	DISPLAY
Turn the power switch on. If the oven is already on, press the Read / Clear key until the following screen is displayed.	SELECT PRODUCT OR READ/CLEAR TO PROGRAM XX:XXPM XXXF
Enter access code "1 6 2 7 3 8".	A: SET TIME B: SET DATE C: PROGRAM PRODUCTS D: NEXT MENU
Select "C".	PRODUCT PROGRAM MODE SELECT PRODUCT NUMBER 1-9
Select a number from 0-9 and press the key corresponding to that number.	EDIT PRODUCT? 1=EDIT OR 2=DELETE NXX TX XXXF CX XX:XX:XX PXXX F-XX
If a product Key selected already has a program, the screen will read.	ENTER COOKING TEMP 100 TO 450 F NOX T1 XXXF
Enter a desired cooking / baking temperature. The screen will automatically advance to the next display.	ENTER COOKING TIME HR:MIN:SEC NOX T1 XXXF CO
Enter the cooking time and then press "E" to advance to the next screen.	ENTER COOKING CURVE 0 TO 100% NOX T1 XXXF CXX XX:XX:XX PXXX F-XX
Enter the desired cooking curve. (Refer to sections 6.3 and 6.7 for more detail)	ENTER FAN SPEED 1=HI 2=LOW NOX T1 XXXF CXX XX:XX:XX PXXX F-XX
Select Fan speed. (Hi=1700 rpm, Low=1400)	ENTER FAN PULSE RATE 1 TO 100% NOX T1 XXXF CXX XX:XX:XX PXX F-XX
Select Fan Pulse rate. (0 to 100%). 0=off unless calling for heat. 100=on at all time. NOTE: Any number between 0-100 means that the fan will be on that many number of seconds in a 100-second block. (E.g. 67%= on for 67 seconds in a 100 second block)	CONTINUE TO TIER 2 1=YES 2=NO NOX T1 XXXF CXX XX:XX:XX PXXX F-XX
If you press 1 you will go through the same sequence as outlined above. If you press 2 the next display will automatically appear.	A: SET TIME B: SET DATE C: PROGRAM PRODUCTS D: NEXT MENU

PROGRAMMING EHS-PT

ACTION	DISPLAY								
<p>Step 1. Turn the power switch on. If the oven is already on, press the "CANCEL" key until the following screen is displayed.</p> <p>Step 2. Select:</p> <p style="text-align: center;">← TIME / DATE / PROGRAM.</p>	 ← RUN OVEN ← TIME / DATE / PROGRAM <table style="width: 100%; border: none;"> <tr> <td style="text-align: left;">TIME</td> <td style="text-align: left;">DATE</td> <td style="text-align: left;">TEMP</td> <td style="text-align: left;">STATUS</td> </tr> <tr> <td style="text-align: left;">12:00</td> <td style="text-align: left;">01/01/01</td> <td style="text-align: left;">325</td> <td style="text-align: left;">STANDBY</td> </tr> </table>	TIME	DATE	TEMP	STATUS	12:00	01/01/01	325	STANDBY
TIME	DATE	TEMP	STATUS						
12:00	01/01/01	325	STANDBY						

ACTION	DISPLAY								
<p>Step 3. Select :</p> <p style="text-align: center;">← PROGRAM COMPUTER</p>	← DISPLAY PRODUCT ← TIMER ONLY ← SET TIME / DATE ← PROGRAM COMPUTER <table style="width: 100%; border: none;"> <tr> <td style="text-align: left;">TIME</td> <td style="text-align: left;">DATE</td> <td style="text-align: left;">TEMP</td> <td style="text-align: left;">STATUS</td> </tr> <tr> <td style="text-align: left;">12:00</td> <td style="text-align: left;">01/01/01</td> <td style="text-align: left;">325</td> <td style="text-align: left;">PROGRAM</td> </tr> </table>	TIME	DATE	TEMP	STATUS	12:00	01/01/01	325	PROGRAM
TIME	DATE	TEMP	STATUS						
12:00	01/01/01	325	PROGRAM						

ACTION	DISPLAY
<p>Step 4. Using the ▲ and ▼ arrows, enter access code "A B C D E F"</p> <p>Press ▲ or ▼ to scroll through letters and numbers, then select "ENTER" to move the cursor to the right.</p> <p><i>EXAMPLE: Press ▲ once for an "A", then press "ENTER". Press ▲ twice for a "B", then select "ENTER". Continue through "F". The screen will then automatically advance once access code has been entered correctly.</i></p>	<div style="border: 1px solid black; border-radius: 15px; padding: 5px; display: inline-block;">ENTER ACCESS CODE</div> A USE ▲▼ KEYS TO SELECT THEN PRESS ENTER ← ENTER PRESS CANCEL TO QUIT

PROGRAMMING EHS-PT CONT'D

ACTION	DISPLAY
<p>Step 5. Select:</p> <p style="text-align: center;">← PROGRAM PRODUCTS</p>	<ul style="list-style-type: none"> <li style="margin-bottom: 10px;">← PROGRAM PRODUCTS <li style="margin-bottom: 10px;">← EDIT READY ZONE <li style="margin-bottom: 10px;">← EDIT ACCESS CODE <li style="margin-bottom: 10px;">← ENABLE MANUAL PRODUCT <li style="margin-bottom: 10px;">← CONFIGURE TIME OF DAY

ACTION	DISPLAY
<p>Step 6. Select:</p> <p style="text-align: center;">← CREATE NEW PRODUCT</p>	<ul style="list-style-type: none"> <li style="margin-bottom: 10px;">← CREATE NEW PRODUCT <li style="margin-bottom: 10px;">← EDIT PRODUCT <li style="margin-bottom: 10px;">← DELETE PRODUCT <li style="margin-bottom: 10px;">← EDIT PRODUCT

ACTION	DISPLAY
<p>Step 7. “SELECT PRODUCT ICON” is the first screen when creating a product program. Press ▼ until you find an icon that best resembles your product. If necessary, press ▲ to go backward through the icon list. Select “ENTER” to accept the icon, and more to the next screen</p>	<p style="text-align: center;">SELECT PRODUCT ICON</p> <p style="text-align: center;">USE ▲▼ KEYS TO SELECT THEN PRESS ENTER TO ACCEPT</p> <div style="display: flex; align-items: center; margin-top: 10px;">  <p>APPETIZER A</p> </div> <p style="margin-top: 20px;">← ENTER</p>

PROGRAMMING EHS-PT CONT'D

ACTION	DISPLAY
<p>Step 8. “SELECT PRODUCT NAME” is where you spell the name using the ▲ or ▼ to select each letter. Then select “ENTER” to move the cursor to the next space and select a new letter.</p> <p>NOTE: “<u>APPETIZER A</u>” is the name that must be replaced with the new product name or blanks, when the product name is shorter than “<u>APPETIZER A</u>”.</p> <p><i>EXAMPLE: “APPLE” replaces only <u>APPET, IZER A</u> must be replace by blanks. A blank can be found before “A” or after “9” when scrolling.</i></p>	<div style="text-align: center; border: 1px solid black; border-radius: 15px; padding: 5px; margin-bottom: 10px;"> SELECT PRODUCT NAME <u>APPETIZER A</u> </div> <p style="text-align: center;">USE ▲▼ KEYS TO SELECT</p> <div style="display: flex; align-items: center; margin-bottom: 10px;"> <div> <p>APPETIZER A</p> </div> </div> <div style="display: flex; flex-direction: column; align-items: flex-start;"> <div style="margin-bottom: 5px;"> ACCEPT </div> <div> ENTER </div> </div>

ACTION	DISPLAY
<p>Step 9. “SELECT PRODUCT TEMPERATURE” Press the ▲ or ▼ to select a number. Then select “ENTER” to move the cursor to the next space and select a new number. The screen will automatically advance after you enter the last number.</p> <p><i>EXAMPLE: (320) Press ▲ three times for a “3”, then select “ENTER” to advance the cursor. Press ▲ two times for a “2”, then select “ENTER” to advance the cursor. Since “0” is already displayed just select “ENTER” to advance to the next screen.</i></p>	<div style="text-align: center; border: 1px solid black; border-radius: 15px; padding: 5px; margin-bottom: 10px;"> SELECT PRODUCT TEMPERATURE 100 </div> <p style="text-align: center;">USE ▲▼ KEYS TO SELECT</p> <div style="display: flex; align-items: center; margin-bottom: 10px;"> <div> <p>APPLE</p> </div> </div> <p>TIER 1</p> <div style="display: flex; flex-direction: column; align-items: flex-start;"> <div style="margin-bottom: 5px;"> ACCEPT </div> <div> ENTER </div> </div>

ACTION	DISPLAY
<p>Step 10. “SELECT TIER COOK TIME”. Time is entered in hours:minutes:seconds. The maximum is 12:59:59. Select “ENTER” to advance cursor to the place you want to enter a number.</p> <p><i>EXAMPLE: (45 minutes:00 seconds) Select “ENTER” twice to advance from hours to minutes, then press ▲ four times for a “4”, then select “ENTER” to advance the cursor. Then press ▲ five times for a “5”, then select “ENTER” to advance the cursor. Since “0” is the next two numbers simply select “ENTER” again twice to advance the cursor.</i></p>	<div style="text-align: center; border: 1px solid black; border-radius: 15px; padding: 5px; margin-bottom: 10px;"> SELECT TIER COOK TIME 00:45:00 </div> <p style="text-align: center;">USE ▲▼ KEYS TO SELECT</p> <div style="display: flex; align-items: center; margin-bottom: 10px;"> <div> <p>APPLE</p> </div> </div> <p>TIER 1 TEMP: 320F</p> <div style="display: flex; flex-direction: column; align-items: flex-start;"> <div style="margin-bottom: 5px;"> ACCEPT </div> <div> ENTER </div> </div>

PROGRAMMING EHS-PT CONT'D

ACTION	DISPLAY
<p>Step 11. "SELECT COOKING CURVE". Press ▲ or ▼ to select numbers, select "ENTER" to move the cursor to the next space. Cooking curve may be any number between 0% and 100%.</p> <p><i>EXAMPLE: (80%) Select "ENTER" once to advance the cursor one space, then press ▲ eight times for a "8". Select "ENTER" to advance the cursor. Since "0" is the next number, select "ENTER" to advance to the next screen.</i></p>	<div style="text-align: center; border: 1px solid black; border-radius: 15px; padding: 5px; margin-bottom: 10px;"> SELECT COOKING CURVE 000 % </div> <p style="text-align: center;">USE ▲▼ KEYS TO SELECT</p> <div style="display: flex; align-items: center; margin-bottom: 10px;"> APPLE </div> <div style="display: flex; justify-content: space-between; margin-bottom: 10px;"> <div style="text-align: left;"> TIER 1 TEMP: 320F </div> <div style="text-align: right;"> TIME: 00:45:00 </div> </div> <div style="margin-top: 10px;"> <p>← ACCEPT</p> <p>← ENTER</p> </div>



ACTION	DISPLAY
<p>Step 12. "SELECT FAN SPEED". The cursor will automatically appear under HIGH, that is your default setting. Press "ENTER" or ACCEPT to keep high fan and advance to the next screen. If LOW is the correct setting press the ▲ or ▼ to move the cursor to low. Once low is selected, select "ENTER" or ACCEPT to move to the next screen.</p>	<div style="display: flex; justify-content: space-between; align-items: center; margin-bottom: 10px;"> HIGH <div style="text-align: center; border: 1px solid black; border-radius: 15px; padding: 5px; flex-grow: 1;"> SELECT FAN SPEED </div> LOW </div> <p style="text-align: center;">USE ▲▼ KEYS TO SELECT</p> <div style="display: flex; align-items: center; margin-bottom: 10px;"> APPLE </div> <div style="display: flex; justify-content: space-between; margin-bottom: 10px;"> <div style="text-align: left;"> TIER 1 TEMP: 320F </div> <div style="text-align: right;"> TIME: 00:45:00 </div> </div> <p>COOKING CURVE: 80 %</p> <div style="margin-top: 10px;"> <p>← ACCEPT</p> <p>← ENTER</p> </div>

PROGRAMMING EHS-PT CONT'D

ACTION	DISPLAY						
<p>Step 13. "SELECT PULSE RATE". Press \blacktriangle or \blacktriangledown to select numbers, select "ENTER" to move the cursor to the next space. 100% is the default. If this okay, select "ENTER" three times or "ACCEPT" once to advance to the next screen.</p> <p><i>EXAMPLE: (80%) Press the \blacktriangledown once for "0". Select "ENTER" once to advance the cursor one space, then press \blacktriangle eight times for a "8". Select "ENTER" to advance the cursor. Since "0" is the next number, select "ENTER" to advance to the next screen.</i></p>	<div style="text-align: center; border: 1px solid black; border-radius: 50%; width: fit-content; margin: 0 auto; padding: 5px;"> SELECT PULSE RATE 100 % </div> <p style="text-align: center;">USE $\blacktriangle\blacktriangledown$ KEYS TO SELECT</p> <div style="display: flex; align-items: center; margin-top: 10px;"> APPLE </div> <p>TIER 1</p> <table style="width: 100%; border: none;"> <tr> <td style="width: 33%;">TEMP: 320F</td> <td style="width: 33%;">TIME: 00:45:00</td> </tr> <tr> <td>FAN: HI</td> <td></td> </tr> <tr> <td>COOKING CURVE: 80 %</td> <td></td> </tr> </table> <div style="margin-top: 10px;"> \blacktriangleleft ACCEPT \blacktriangleleft ENTER </div>	TEMP: 320F	TIME: 00:45:00	FAN: HI		COOKING CURVE: 80 %	
TEMP: 320F	TIME: 00:45:00						
FAN: HI							
COOKING CURVE: 80 %							

ACTION	DISPLAY						
<p>Step 14. "CORRECT". The cursor automatically appears on "YES". The computer is asking if the program displayed is correct. If any part of that program is incorrect, press \blacktriangle or \blacktriangledown till the cursor is on "NO". Select "ENTER" or "ACCEPT". This will return you to step 7. Selecting "YES" will advance the screen. "NO".</p>	<div style="display: flex; justify-content: space-between; align-items: center;"> <div style="text-align: center;"><u>YES</u></div> <div style="text-align: center; border: 1px solid black; border-radius: 50%; width: fit-content; padding: 5px;"> CORRECT? </div> <div style="text-align: center;">NO</div> </div> <p style="text-align: center;">USE $\blacktriangle\blacktriangledown$ KEYS TO SELECT</p> <div style="display: flex; align-items: center; margin-top: 10px;"> APPLE </div> <p>TIER 1</p> <table style="width: 100%; border: none;"> <tr> <td style="width: 33%;">TEMP: 320F</td> <td style="width: 33%;">TIME: 00:45:00</td> </tr> <tr> <td>FAN: HI</td> <td>RATE: 100 %</td> </tr> <tr> <td>COOKING CURVE: 80 %</td> <td></td> </tr> </table> <div style="margin-top: 10px;"> \blacktriangleleft ACCEPT \blacktriangleleft ENTER </div>	TEMP: 320F	TIME: 00:45:00	FAN: HI	RATE: 100 %	COOKING CURVE: 80 %	
TEMP: 320F	TIME: 00:45:00						
FAN: HI	RATE: 100 %						
COOKING CURVE: 80 %							

PROGRAMMING EHS-PT CONT'D

ACTION	DISPLAY						
<p>Step 15. “CONTINUE TO NEXT TIER”. The cursor automatically appears on “<u>NO</u>”. Select “ENTER” or “ACCEPT” to end programming or move the cursor with the ▲ or ▼ to “<u>YES</u>”. This will allow you to enter another tier to this program. Repeat steps 6-14 to program second tier.</p>	<div style="text-align: center;">  </div> <p style="text-align: center;"> YES <u>NO</u> USE ▲▼ KEYS TO SELECT </p> <div style="text-align: center; margin: 10px 0;">  APPLE </div> <p>TIER 1</p> <table style="width: 100%; border: none;"> <tr> <td style="width: 50%;">TEMP: 320F</td> <td style="width: 50%;">TIME: 00:45:00</td> </tr> <tr> <td>FAN: HI</td> <td>RATE: 100 %</td> </tr> <tr> <td colspan="2">COOKING CURVE: 80 %</td> </tr> </table> <p style="margin-top: 20px;"> ACCEPT ENTER </p>	TEMP: 320F	TIME: 00:45:00	FAN: HI	RATE: 100 %	COOKING CURVE: 80 %	
TEMP: 320F	TIME: 00:45:00						
FAN: HI	RATE: 100 %						
COOKING CURVE: 80 %							

ACTION	DISPLAY
<p>Step 16. After programming the last tier, select “<u>NO</u>” when asked “CONTINUE TO NEXT TIER” the computer will automatically advance the screen to program more products. If no other products need to be programmed, select “CANCEL” three times to advance screen to the boot up screen.</p>	<ul style="list-style-type: none"> <li style="margin-bottom: 10px;"> CREATE NEW PRODUCT <li style="margin-bottom: 10px;"> EDIT PRODUCT <li style="margin-bottom: 10px;"> DELETE PRODUCT <li style="margin-bottom: 10px;"> EDIT PRODUCT

ACTION	DISPLAY								
<p>Step 17. You may now preheat the oven for any products you have programmed.</p> <p>Step 18. Select:</p> <p style="margin-left: 40px;">◀ Run oven</p>	<div style="text-align: center; margin-bottom: 20px;">  </div> <ul style="list-style-type: none"> <li style="margin-bottom: 20px;"> RUN OVEN <li style="margin-bottom: 20px;"> TIME / DATE / PROGRAM <table style="width: 100%; border: none; margin-top: 20px;"> <tr> <td style="width: 25%;">TIME</td> <td style="width: 25%;">DATE</td> <td style="width: 25%;">TEMP</td> <td style="width: 25%;">STATUS</td> </tr> <tr> <td>12:00</td> <td>01/01/01</td> <td>325</td> <td>STANDBY</td> </tr> </table>	TIME	DATE	TEMP	STATUS	12:00	01/01/01	325	STANDBY
TIME	DATE	TEMP	STATUS						
12:00	01/01/01	325	STANDBY						

OPERATIONS

- Convection ovens constantly circulate air over the product. This strips away the thin layer of moisture and cool air from the top of the product. Heat penetrates more quickly. Cooking times are shortened and cooking temperatures are usually reduced.
- To convert standard deck oven recipes to convection oven recipes, reduce the temperature 50 °F and the time by 25%. Make adjustments as necessary, depending upon your results.
- The lower the temperature the more even the bake.
- Check the product halfway through the baking cycle. Look through the door windows. Opening the oven door is not recommended.
- If products are brown on the outside and not done on the inside, too high a temperature is being used. Decrease the temperature 15-25 °F.
- If products are pulling to the edge of pans or spilling, the oven is not leveled or the pans are warped. Correct as necessary.
- Load each shelf evenly. Spaces should be maintained equally between the pan and walls. Front and back. This will allow an even distribution of airflow.

BAKING

- Most baking should be done with the vent closed. Open the vent only with high moisture products to avoid seepage around the front of the door.
- Always weigh your product. This will give you a more consistent size, color and quality.
- Center the pan in the oven. The better the air flow around the product, the better the bake.
- The convection oven is a mechanical piece of equipment. The same control settings will always give the same results. If the results vary, problems may be because of preparation, not the oven.

LOADING

- Place product as close to oven as practical. Open oven doors and load quickly but carefully.
- If only one pan is required, load on center shelf. If two pans are required, load on second and fourth shelf. If three pans are required, load on top shelf, bottom shelf, and center shelf. If four pans are required, load on top shelf, bottom shelf, and middle two shelves. If five shelves are required, space evenly in oven. (See page 27 for more detail)

UNLOADING

- It is a characteristic of all convection ovens to unload the top shelf before the bottom shelves. The rising of heat and the hot oven ceiling causes the top shelf to bake quicker. This characteristic is more pronounced when baking at higher temperatures and/or for prolonged periods of time.

GENERAL CONT'D

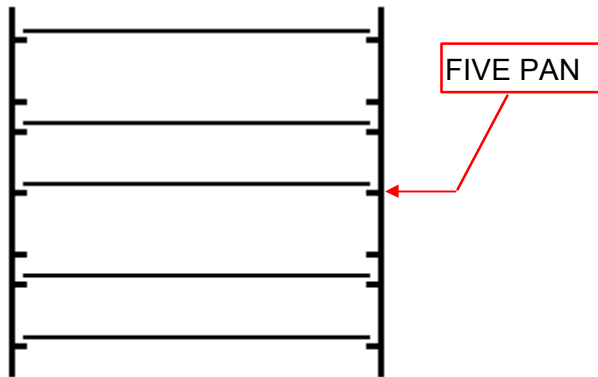
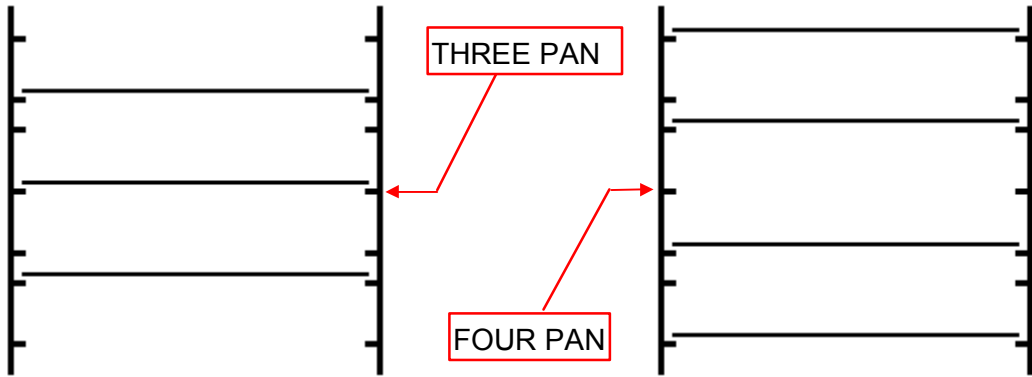
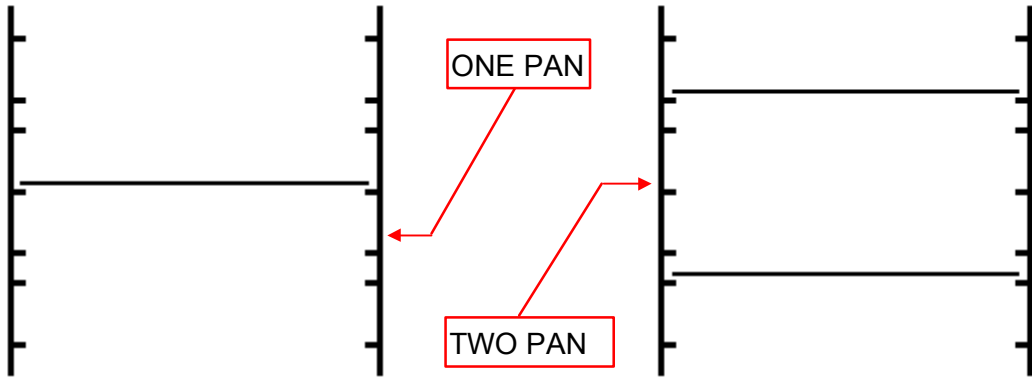

EHS-T TYPICAL OPERATION SEQUENCE

ACTION	RESULT
Turn power switch to ON.	
Adjust proper temperature, between 140 & 450 degrees and allow to preheat up to 20 minutes.	Oven begins heating.
Open oven doors and insert product, set timer up to 60 minutes.	Timer begins counting down.
Timer beeps continuously when done.	Product should now be done.

EHS-AP TYPICAL OPERATION SEQUENCE

ACTION	RESULT
Turn power switch to ON.	Control panel heat call light comes on.
Adjust proper temperature, between 140 & 450 degrees and allow to preheat up to 20 minutes.	Oven begins heating.
Open oven doors and insert product, set timer up to 60 minutes.	Timer begins counting down.
Timer beeps continuously when done.	Product should now be done.

EHS-C TYPICAL OPERATION SEQUENCE

ACTION	RESULT
Turn power switch to ON.	Control panel comes on, display says “ BBBBB ” and then “ EntEr ”, motor starts.
Press a product button.	Display says “ Pr-Eht ” (Preheat), oven begins to heat to the programmed temperature.
<i>Beeper sounds briefly.</i>	Display says “ r-ERdy ”.
Open the oven doors and load the product. Close the door and press the product button again.	Beeper sounds briefly and display says “ ShELF ”.
Press the shelf button(s) which correspond to the shelf positions which the product is loaded (A equals the top shelf and E equals the bottom shelf).	Display shows a countdown timer and begins to count toward zero.
<i>Beeper sounds continuously.</i>	Display shows “ donE ”, shelf button(s) flash.
Press the flashing shelf button(s).	Beeper stops. Display shows “ r-ERdy ” if no other shelves carry product or resume count down for shelves that still have product cooking.
Open oven door and remove the product, which corresponds to flashing shelf button(s).	

EHS-PT TYPICAL OPERATION SEQUENCE

ACTION	RESULT
Press the on switch.	Control panel comes on, display says “LANG, Run Oven, Time Date Program.”
Select “Run Oven” .	Display will show a list of product to choose.
Select Product button next to Icon desired.	Display says “Preheating to XXXF” .
<i>Beeper sounds briefly.</i>	Display says “Ready” .
Select Product to start.	Display shows possible product selection for that temperature.
Select Product to start.	Display says “Select shelf” .
Press Product button next to desired shelf.	Display will show icon chosen and begin to count down.
<i>Beeper sounds continuously.</i>	Display shows “ DONE” press button and remove product from that shelf.
Oven is ready for another product.	

EHS-PP TYPICAL OPERATION SEQUENCE

ACTION	RESULT
Turn power switch to ON.	Control panel comes on, display says “SELECT PRODUCT OR READ/CLEAR TO PROGRAM.”
Press a product button.	Display says “PRODUCT X PREHEATING TO XXX F” . Motor starts and oven begins preheating to the programmed temperature.
<i>Beeper sounds briefly.</i>	Display says “READY SELECT PRODUCT TO START ” .
Open the oven doors and load the product. Close the door and press the product button again.	Beeper sounds briefly and display says “SELECT OVEN SHELVES PRODUCT X” .
Press the shelf button(s) which correspond to the shelf positions just left, which the product is loaded (A equals the top shelf and E equals the bottom shelf).	Display shows a countdown timer and begins to count toward zero.
<i>Beeper sounds continuously.</i>	Display shows “DONE PRESS SHELF BUTTON X, REMOVE PRODUCT” , shelf button(s) flash.
Press the flashing shelf button(s).	Beeper stops. Display shows “READY SELECT PRODUCT TO START” if no other shelves carry product or resume count down for shelves that still have product cooking.
Open oven door and remove the product, which corresponds to flashing shelf button(s).	

SEQUENCE OF OPERATION EHS-T

Power switch turned on.

240/208 VAC across Common terminals on power switch and “B” terminal of 12 pin **Terminal block**.
240/208 VAC to Common terminals of **Motor relay**.

240/24-volt transformer energized.

24 VAC across “C” and “D” (common) of 24 pin **Terminal block**.
24 VAC across coil of **Motor relay**. (Through door switch)
24 VAC across “D” and of **Heat contactor**. (Through door switch and high limit thermostat)
24 VAC across “D” and terminal on thermostat.
Motor contactor closes.

Motor starts.

24 VAC across coil of **Heat contactor**.
Heat contactor closes.
208/240 volts to elements.
Oven heats.

SEQUENCE OF OPERATION EHS-AP

Power switch turned on.

240/208 VAC across Common terminals on power switch and “B” terminal of 12 pin **Terminal block**.
240/208 VAC to Common terminals of **Motor relay**.

240/24-volt transformer energized.

24 VAC across “C” and “D” (common) of 24 pin **Terminal block**.
24 VAC across coil of **Motor relay**. (Through door switch)
24 VAC across “D” and of **Heat contactor**. (Through door switch and high limit thermostat)
24 VAC across “D” and Heat output on board.
Motor contactor closes.

Motor starts.

24 VAC across coil of **Heat contactor**.
Heat contactor closes.
208/240 volts to elements.
Oven heats.

SEQUENCE OF OPERATION EHS-C

Power switch turned on.

240/208 VAC across Common terminals on power switch and “A” terminal of 24 pin **Terminal block**.
240/208 VAC across any “A” and “B” terminal of 24 pin **Terminal block**.
240/208 VAC to Common terminals of **Motor relay**.
240/208 VAC across common terminals of **Back-up toggle switch**.
120 VAC to coil of **Back-up relay**.

240/24 volt transformer energized.

24 VAC across “C” and “D” (common) of 24 pin **Terminal block**.
24 VAC across “D” and coil of **Motor relay**. (Through door switch)
24 VAC across “D” and of **Heat contactor**. (Through door switch and high limit thermostat)
24 VAC across “D” and Common terminals of **Back-up relay**.
240/12 volt transformer energized.

Back-up toggle switch Off.

24 VAC across “D” and TP4, TP5 and TP6.
12 volts to TP1 on **microprocessor**.
24 VAC across coil of **motor contactor**.
Motor contactor closes.
240/208 VAC across NO (Normally open) contacts of **Motor relay**.

Motor starts.

24 VAC across coil of **Heat contactor**.
Heat contactor closes.
208/240 volts to elements.
Oven heats.

Back-up toggle switch Off.

208/240 VAC across coil of **Back-up relay**.

Back-up relay closes.

24 VAC across and **Back-up Thermostat** (With door switch energized.)
24 VAC across coil of **Motor relay**.
Motor contactor closes.
240/208 VAC across NO (Normally open) contacts of **Motor relay**.

Motor starts.

Temperature set on back up thermostat.
24 VAC across “D” and each terminal of back-up thermostat.
24 VAC across coil of **Heat contactor**.
Heat contactor closes.
208/240 volts to elements.

SEQUENCE OF OPERATION EHS-PP/PT

Oven plugged in.

208/240 VAC across any “A” and “B” terminal on the terminal block.
208/240 VAC to Control transformer (208-240VAC / 24-12 VAC) and Component transformer
240VAC / 24VAC.

Transformers energize.

24 VAC to any “C” and “D” terminal on the terminal block.
24 / 12 VAC to Circuit Board (JP40).
24 VAC to Circuit Board outputs (JP11- JP13).

Power Switched turned to “ON”.

Display comes on.

Product selected.

24 VAC across motor output (JP12) and “D”.
24 VAC across motor HI relay coil.
Motor relay closes.
208/240 VAC to motor.

Motor Starts.

24 VAC across heat output (JP11) and “D”.
24 VAC across heat contactor (through over-temperature thermostat).
Heat contactor closes.
208/240 VAC to elements.

Back up toggle switch to “ON” .

208/240 VAC across coil of back up relay coil.

Back up relay energizes.

24 VAC to motor relay.
Motor relay energizes.
208/240 VAC to motor.

Motor Starts.

24 VAC to thermostat.

Temperature set on thermostat.

24 VAC to heat contactor.
Contactor energizes.
208/240 VAC to elements.

TROUBLESHOOTING EHS-T

HINT: Confirm that all Circuit Breakers are in the “ON” position.

NO MOTOR

PROBABLE CAUSE	CORRECTIVE ACTION
Defective Fan Switch	➤ Verify that Fan switch is in “ON” position (In pulse position motor will only cycle when oven calls for heat).
Defective Transformer	➤ Check transformer for normal operation.
Defective Motor Relay	➤ Check motor relay for normal operation. (24VAC 35 Ω)
Defective Door Switch	➤ Check door switch for normal operation.
Defective Motor	➤ Check motor for normal operation. (P1-T9 low, P1-T7/T4 high)

NO HEAT

PROBABLE CAUSE	CORRECTIVE ACTION
Defective Elements	<ul style="list-style-type: none"> ➤ Check that elements are getting power. ➤ Confirm that Elements are working correctly. (See Technical Data)
Defective Transformer	<ul style="list-style-type: none"> ➤ Check transformer for normal operation. ➤ Replace if necessary.
Defective Heat Contactor	<ul style="list-style-type: none"> ➤ Confirm that Contactor is getting correct voltage. ➤ Confirm that Contactor is operating properly. (24VAC 6Ω)
Defective Thermostat	<ul style="list-style-type: none"> ➤ Confirm that Thermostat is getting 24 VAC. Measure between Thermostat terminal and “D” on the terminal block <p>If voltage is not present:</p> <ul style="list-style-type: none"> ➤ Check Transformer for normal operation. <p>If voltage is present:</p> <ul style="list-style-type: none"> ➤ Check thermostat for continuity. ➤ Replace as necessary

TROUBLESHOOTING EHS-AP

HINT: Confirm that all Circuit Breakers are in the “ON” position.

NO MOTOR

PROBABLE CAUSE	CORRECTIVE ACTION
Defective Fan Switch	➤ Verify that Fan switch is in “ON” position (In pulse position motor will only cycle when oven calls for heat).
Defective Transformer	➤ Check transformer for normal operation.
Defective Motor Relay	➤ Check motor relay for normal operation. (24VAC 35 Ω)
Defective Door Switch	➤ Check door switch for normal operation.
Defective Motor	➤ Check motor for normal operation. (P1-T9 low, P1-T7/T4 high)

NO HEAT

PROBABLE CAUSE	CORRECTIVE ACTION
Defective Elements	<ul style="list-style-type: none"> ➤ Check that elements are getting power. ➤ Confirm that Elements are working correctly. (See Technical Data)
Defective Transformer	<ul style="list-style-type: none"> ➤ Check transformer for normal operation. ➤ Replace if necessary.
Defective Probe	➤ Confirm that probe has proper resistance for the correct temp. (See Technical Data)
Defective Heat Contactor	<ul style="list-style-type: none"> ➤ Confirm that Contactor is getting correct voltage. ➤ Confirm that Contactor is operating properly. (24VAC 6Ω)
Defective Thermostat	<ul style="list-style-type: none"> ➤ Confirm that Heat Call light is on. If no light is detected: <ul style="list-style-type: none"> ➤ Check 12-position switch for normal operation. (See Technical Data) If light is detected: <ul style="list-style-type: none"> ➤ Check for 24VAC across heat output and “D” on 12 Pole terminal. If voltage is not present: <ul style="list-style-type: none"> ➤ Replace Circuit board. If voltage is present: <ul style="list-style-type: none"> ➤ Check over temperature thermostat for proper operation. ➤ Check door switch for normal operation.

TROUBLESHOOTING EHS-C

- To help troubleshoot the oven you should perform the following “Manual Override” test:
- Open drop down door located on the lower right side, directly below front panel.
- Turn back up toggle (on/off) switch to “on” position.
- Turn main power switch to “on” position.
- Check oven for normal operation.
- If fan comes on and unit heats up refer to section 4.1 (NO DISPLAY).
- If fan does not come on refer to section 4.2 (NO FAN).

NO DISPLAY

PROBABLE CAUSE	CORRECTIVE ACTION
Power switch is not turned on	<ul style="list-style-type: none"> ➤ Turn power switch on.
Defective power switch	<ul style="list-style-type: none"> ➤ Check power switch for normal operation. Replace as necessary.
Defective back-up relay	<ul style="list-style-type: none"> ➤ Check relay for normal operation. ➤ Check coil for 24 VAC. <p>If 24 VAC is measured. Turn oven off and:</p> <ul style="list-style-type: none"> ➤ Check coil for 7.2 KΩ. ➤ Replace as necessary. <p>If 24 VAC is not measured.</p> <ul style="list-style-type: none"> ➤ Verify that manual override switch is in “off” position. ➤ Check manual override switch for normal operation. ➤ Check wires for any shorts.
Defective control transformer (12 VAC).	<ul style="list-style-type: none"> ➤ Check transformer for normal operation. ➤ Check primary coil for 208/240 VAC and 630 Ω. Check secondary coil for no less than 10.5 VAC and 1 Ω. <p>If voltage is measured on primary:</p> <ul style="list-style-type: none"> ➤ Check for voltage on secondary. ➤ Replace transformer. <p>If voltage is not measured on primary:</p> <ul style="list-style-type: none"> ➤ Check wires for any shorts.
Defective rectifier	<ul style="list-style-type: none"> ➤ Check for no less than 10.5 VAC on TP1 and 5 VDC on TP2. ➤ If correct voltage is present at TP1 and present, but low at TP2 unplug both ribbon connections from CPU and re-measure at TP2. ➤ If voltage remains low at TP2 replace CPU (40102-311). ➤ If voltage at TP2 increased to 5 VDC when ribbon was unplugged, plug ribbon back in to CPU and disconnect from Interface board. ➤ Re-measure at TP2. ➤ If voltage dropped to below 5 VDC replace ribbon cable (31110-01). ➤ If voltage remains at 5 VDC, plug ribbon back into Interface board and measure for 5 VDC at TP3. ➤ If voltage is present at TP3 and display is still not on, press and hold the R/C button on board if LED’s come on replace Interface board. ➤ If LED segment does not illuminate or the LED is blank, replace LED.

TROUBLESHOOTING EHS-C CONT'D

NO FAN-Manual Mode

PROBABLE CAUSE	CORRECTIVE ACTION
Defective 240/24 VAC transformer	<ul style="list-style-type: none"> ➤ Check for 24 VAC on “C” and “D” of the terminal block. <p>If 24 VAC is not measured: Turn off and:</p> <ul style="list-style-type: none"> ➤ Check secondary coil for 1 Ω. ➤ Check primary coil for 77 Ω. ➤ Replace transformer. <p>If 24 VAC is measured: Turn off and:</p> <ul style="list-style-type: none"> ➤ Check back-up relay for normal operation.
Back-up relay not energizing	<ul style="list-style-type: none"> ➤ Check for 240 VAC on relay coil. <p>If 240 VAC is measured: Turn unit off and:</p> <ul style="list-style-type: none"> ➤ Check back-up relay coil for 7.2 K Ω. ➤ Replace if defective. <p>If 240 VAC is not measured:</p> <ul style="list-style-type: none"> ➤ Check back-up switch (SPDT) for normal operation. ➤ Replace if defective.
Motor contactor not energized	<ul style="list-style-type: none"> ➤ Check for 24 VAC at contactor or relay coil. <p>If 24 VAC is not measured: Turn oven off and:</p> <ul style="list-style-type: none"> ➤ Check door switch for normal operation. ➤ Check door switch for continuity. ➤ Replace or adjust door switch. <p>If 24 VAC is measured: Turn unit off and:</p> <ul style="list-style-type: none"> ➤ Check contactor coil for continuity. ➤ Replace if defective.
No voltage across contactor points	<ul style="list-style-type: none"> ➤ Check 208/240 VAC across “C” terminals of contactor. <p>If 208/240 VAC is not measured:</p> <ul style="list-style-type: none"> ➤ Check connection to main contactor (heat contactor). ➤ Check circuit breaker. <p>If 208/240 VAC is measured:</p> <ul style="list-style-type: none"> ➤ Check across “NO” contacts. Should have 208/240 VAC. ➤ Replace if defective.

NO MOTOR COMPUTER MODE

PROBABLE CAUSE	CORRECTIVE ACTION
No 24 VAC on Interface board	<ul style="list-style-type: none"> ➤ Check for 24 VAC at TP4 to common (“D”). <p>If 24 VAC is not measured:</p> <ul style="list-style-type: none"> ➤ Check for 24 VAC at “NC” contacts on back-up relay. <p>If 24 VAC is measured:</p> <ul style="list-style-type: none"> ➤ Check for 24 VAC at TP5. ➤ Replace Interface board if defective.

TROUBLESHOOTING EHS-C CONT'D

NO HEAT Manual Mode

NOTE: Fan must be operating before trouble shooting No heat.

PROBABLE CAUSE	CORRECTIVE ACTION
Back-up relay not energizing	<ul style="list-style-type: none"> ➤ Check for 240 VAC on relay coil. <p>If 240 VAC is measured. Turn unit off and:</p> <ul style="list-style-type: none"> ➤ Check back-up relay coil for 7.2 Ω. ➤ Check “NO” contacts for 24 VAC. ➤ Replace if defective. <p>If 240 VAC is not measured:</p> <ul style="list-style-type: none"> ➤ Check back-up switch (SPDT) for normal operation. ➤ Replace if defective.
Defective thermostat	<ul style="list-style-type: none"> ➤ Turn unit off and check for continuity while cycling thermostat on and off. ➤ Replace if defective.
Defective contactor	<ul style="list-style-type: none"> ➤ Check for 24 VAC at heater coil. <p>If 24 VAC is measured. Turn oven off and:</p> <ul style="list-style-type: none"> ➤ Check for continuity through coil. ➤ Replace if defective. <p>If 24 VAC is not measured. Turn oven off and:</p> <ul style="list-style-type: none"> ➤ Check for continuity through hi-temp wires going to over-temp thermostat. ➤ Replace over-temp thermostat if defective.
Defective elements	<ul style="list-style-type: none"> ➤ Check elements for continuity. ➤ Replace if defective.
Defective over-temp thermostat	<ul style="list-style-type: none"> ➤ Check for 24 VAC on #55 red wire to common “D”. <p>If 24 VAC is not measured: Turn oven off and:</p> <ul style="list-style-type: none"> ➤ Check for continuity through over-temp thermostat. ➤ Replace if defective.

NO HEAT Computer Mode

PROBABLE CAUSE	CORRECTIVE ACTION
No 24 VAC on Interface board	<ul style="list-style-type: none"> ➤ Check for 24 VAC at TP4 to ground. <p>If 24 VAC is not measured:</p> <ul style="list-style-type: none"> ➤ Check for 24 VAC at “NC” contacts on back-up relay. <p>If 24 VAC is measured:</p> <ul style="list-style-type: none"> ➤ Check for 24 VAC at TP6. ➤ Replace Interface board if defective.

TROUBLESHOOTING EHS-C CONT'D

DISPLAY LOCKS UP

PROBABLE CAUSE	CORRECTIVE ACTION
“Help” in display	<ul style="list-style-type: none"> ➤ Check probe for proper resistance. ➤ Check that probe connections are secure. ➤ Push “TEMP” button on control board and check to see if temperature rapidly descends. If temp does descend rapidly, replace ribbon cable. ➤ Check to see that contactors/relays are not stuck in the closed position. ➤ Replace contactor if defective. ➤ Check for foreign objects keeping contactor closed.
“88888” stuck in display	<ul style="list-style-type: none"> ➤ Check for stuck button by pressing any button. <p>If computer beeps or chirps:</p> <ul style="list-style-type: none"> ➤ Check control panel transformer (12 VAC) for proper operation. ➤ Check TP1 for at least 10.5 VAC. ➤ Check TP2 for at least 4.99 VDC. ➤ Check TP3 for at least 4.97 VDC. <p>If computer does not beep or chirp:</p> <ul style="list-style-type: none"> ➤ Check each button for movement. ➤ Check that panel label has not been damaged in any way. ➤ Replace button if defective. ➤ Replace panel label.
Display has shelf “A”	<ul style="list-style-type: none"> ➤ Read Programming Codes.

TROUBLESHOOTING EHS-PP / -PT

- To help troubleshoot the oven you should perform the following “Manual Override” test:
- Open drop down door located on the lower right side, directly below front panel.
- Turn back up toggle (on/off) switch to “on” position.
- Turn main power switch to “on” position.
- Check oven for normal operation.

NO DISPLAY

PROBABLE CAUSE	CORRECTIVE ACTION
Defective Power Switch (-PP only)	<ul style="list-style-type: none"> ➤ Confirm that toggle switch is getting correct voltage. ➤ Check power switch for normal operation.
Defective Power Switch output on circuit board (JP37)	<ul style="list-style-type: none"> ➤ Confirm that JP37 has 5VDC in the off position and nominal voltage in the on position. ➤ If JP37 has a constant 5VDC check toggle switch for normal operation.
Defective Control Transformer	<ul style="list-style-type: none"> ➤ Confirm that 208/240VAC is feeding primary coil. ➤ Confirm that 24VAC and 12VAC is at JP40 (24VAC across solid yellow wires and 12VAC from one solid yellow wire to yellow with red stripe).
Defective Display	<ul style="list-style-type: none"> ➤ Check ribbon cable connections. ➤ Confirm that voltage is present at JP40. <p>If no voltage is present:</p> <ul style="list-style-type: none"> ➤ Replace control transformer. <p>If voltage is present:</p> <ul style="list-style-type: none"> ➤ Confirm that CPU has 5VDC at TP1 (this means that the CPU is getting correct voltage). ➤ Confirm that CPU has 12VDC at TP2 (this means that the CPU is sending out the correct voltage). <p>If no voltage is present:</p> <ul style="list-style-type: none"> ➤ Replace CPU. <p>If voltage is present:</p> <ul style="list-style-type: none"> ➤ Replace display.

IMPORTANT NOTICE: Power must be disconnected at source when disconnecting any ribbon cable or any connector from CPU or Display. Failure to do so will result in damage to the Display board and CPU.

TROUBLESHOOTING EHS-PP / -PT CONT'D

NO MOTOR, MANUAL MODE

PROBABLE CAUSE	CORRECTIVE ACTION
Defective back-up toggle switch	<ul style="list-style-type: none"> ➤ Confirm that toggle switch is in the “ON” position. ➤ Check toggle switch for normal operation.
Defective back-up relay	<ul style="list-style-type: none"> ➤ Check for 208/240VAC at relay coil. <p>If no voltage is present:</p> <ul style="list-style-type: none"> ➤ Confirm that points are making. <p>If voltage is present:</p> <ul style="list-style-type: none"> ➤ Replace relay.
Defective component transformer	<ul style="list-style-type: none"> ➤ Confirm that 208/240VAC is feeding primary coil. ➤ Confirm that 24VAC is at secondary coil.
Defective motor relay	<ul style="list-style-type: none"> ➤ Check for 24VAC at relay coil. <p>If no voltage is present:</p> <ul style="list-style-type: none"> ➤ Confirm that points are making. <p>If voltage is present:</p> <ul style="list-style-type: none"> ➤ Replace relay.
Defective motor	<ul style="list-style-type: none"> ➤ Check for 208/240VAC across P1 and T7/T4. <p>If no voltage is present:</p> <ul style="list-style-type: none"> ➤ Confirm that wires have continuity. <p>If voltage is present:</p> <ul style="list-style-type: none"> ➤ Replace motor.

NO MOTOR, COMPUTER MODE

IMPORTANT NOTICE: Before trying to trouble shoot “No Motor in Computer Mode” confirm that motor is operational in “Manual Mode”.

PROBABLE CAUSE	CORRECTIVE ACTION
Defective output on CPU board	<ul style="list-style-type: none"> ➤ Check for 24VAC at JP12 for high or JP13 for low (while oven is calling for heat). <p>If no voltage is present:</p> <ul style="list-style-type: none"> ➤ Board is operating correctly. <p>If voltage is present:</p> <ul style="list-style-type: none"> ➤ Replace CPU.

TROUBLESHOOTING EHS-PP / -PT CONT'D

NO HEAT, MANUAL MODE

PROBABLE CAUSE	CORRECTIVE ACTION
Defective back-up toggle switch Defective back-up relay	<ul style="list-style-type: none"> ➤ Confirm that toggle switch is in the “ON” position. ➤ Check toggle switch for normal operation. ➤ Check for 208/240VAC at relay coil. <p>If no voltage is present:</p> <ul style="list-style-type: none"> ➤ Confirm that points are making. <p>If voltage is present:</p> <ul style="list-style-type: none"> ➤ Replace relay.
Defective component transformer Defective Thermostat	<ul style="list-style-type: none"> ➤ Confirm that 208/240VAC is feeding primary coil. ➤ Confirm that 24VAC is at secondary coil. ➤ Confirm that thermostat has 24VAC. <p>If no voltage is present</p> <ul style="list-style-type: none"> ➤ Check component transformer and wiring for normal operation. <p>If voltage is present</p> <ul style="list-style-type: none"> ➤ Check thermostat for normal operation. Replace as necessary.
Defective heat contactor Defective elements	<ul style="list-style-type: none"> ➤ Check for 24VAC at relay coil. <p>If no voltage is present:</p> <ul style="list-style-type: none"> ➤ Confirm that points are making. <p>If voltage is present:</p> <ul style="list-style-type: none"> ➤ Replace contactor. <ul style="list-style-type: none"> ➤ Check for 208/240VAC across elements. <p>If no voltage is present:</p> <ul style="list-style-type: none"> ➤ Confirm that wires have continuity. <p>If voltage is present:</p> <ul style="list-style-type: none"> ➤ Replace elements.

NO HEAT, COMPUTER MODE

IMPORTANT NOTICE: Before trying to trouble shoot “No Heat in Computer Mode” confirm that the oven heats in “Manual Mode”.

PROBABLE CAUSE	CORRECTIVE ACTION
Defective output on CPU board	<ul style="list-style-type: none"> ➤ Check for 24VAC at JP11 (while oven is calling for heat). <p>If no voltage is present:</p> <ul style="list-style-type: none"> ➤ Board is operating correctly. <p>If voltage is present:</p> <ul style="list-style-type: none"> ➤ Replace CPU.

TROUBLESHOOTING EHS-PP / -PT CONT'D

ANOMALIES

PROBABLE CAUSE	CORRECTIVE ACTION
Display will intermittently blank out	<ul style="list-style-type: none">➤ Check ribbon cable for good connections➤ Check panel label buttons and confirm that none of the domes are collapsed. <p>If domes are collapsed:</p> <ul style="list-style-type: none">➤ Replace panel label.
Intermittently over heats or under cooks	<ul style="list-style-type: none">➤ Check probe for proper resistance.➤ Check ribbon connection for good connection.➤ Check probe for good connection.

ELEMENT RESISTANCE

➤ 208 Volt	17 Ω
➤ 240 Volt	23 Ω
➤ 480 Volt	60 Ω

TRANSFORMER RESISTANCE

➤ TRANSFORMER	Input	Primary		Secondary		Output
➤ 208/24 Volt	208/240 Volt	77 Ω		1Ω		24 Volt
➤ 240/12 Volt	208/240 Volt	630 Ω		1 Ω		12 Volt
➤ 208/240-24/12	208/240 Volt	208V 64 Ω	240V 75Ω	12V .6Ω	24V 1Ω	24/12 Volts

CONTACTOR RESISTANCE

➤ CONTACTOR	Coil
➤ 3 Pole 24 Volt coil	6 Ω
➤ 2 Pole 24 Volt coil (P & B) (PP & PT motor)	35 Ω

RELAY RESISTANCE

➤ RELAY	Coil
➤ 240 VAC	7.2 KΩ

OVER-TEMP THERMOSTAT

➤ OVER-TEMP	
➤ Wires #21 and #17	Normally closed

DOOR SWITCH

- Check switch between “COM” (common) and “NO” (normally open) contacts, insure switch closes approximately 3 to 4 inches before door closes.

BLOWER FAN

- Blower fan will rotate clockwise and should have a 5/8“ gap between it and the back wall of the can.

TECHNICAL DATA CONT'D

AUTO/BYPASS SWITCH

The Auto / Bypass and Energy switch are located below the controls behind a pull down access panel.

- Auto/Bypass switch Normally in **“OFF”**. The **“ON”** position will interrupt power to the computer and allow use of the back-up thermostat.
- Energy switch Normally in **“HIGH”** for 11 kW heats. **“LOW”** WILL PROVIDE 8.25 kW heat. Not provided on Steam convection ovens.

LINE AMPERAGE, WATTAGE, AND PROPER PHASING

MODEL	KW per connection	Nominal Amps Per Line						Single Phase	
		Three Phase						208 V	240 V
		208 Volt			240 Volt				
		L1	L2	L3	L1	L2	L3		
EHS	7.8	23.3	20.8	23.3	20.2	18	20.2	38.9	33.8

PHASING				
THREE PHASE			SINGLE PHASE	
L1	L2	L3	L1	L2
1,4	2,5	3,6	1,3,5	2,4,6

EHS-PT / PP COOKING CURVE CONVERSION

Old Style Purple	New Style Platinum / Purple Plus
0	0%
1	17%
2	26%
3	40%
4	50%
5	56%
6	63%
7	71%

TECHNICAL DATA CONT'D

PROBE RESISTANCE

TEMP	RESISTANCE	VOLT DROP	TEMP	RESISTANCE	VOLT DROP
➤ 70	556	1.11	➤ 290	881	1.76
➤ 80	569	1.14	➤ 300	897	1.79
➤ 90	583	1.17	➤ 310	914	1.83
➤ 100	596	1.19	➤ 320	931	1.86
➤ 110	610	1.22	➤ 330	948	1.90
➤ 120	623	1.25	➤ 340	965	1.93
➤ 130	637	1.27	➤ 350	983	1.97
➤ 140	651	1.3	➤ 360	1000	2.00
➤ 150	665	1.33	➤ 370	1018	2.04
➤ 160	678	1.36	➤ 380	1036	2.07
➤ 170	694	1.39	➤ 390	1054	2.11
➤ 180	709	1.42	➤ 400	1072	2.14
➤ 190	724	1.45	➤ 410	1090	2.18
➤ 200	739	1.48	➤ 420	1109	2.22
➤ 210	754	1.51	➤ 430	1127	2.25
➤ 220	769	1.54	➤ 440	1146	2.29
➤ 230	785	1.57	➤ 450	1165	2.33
➤ 240	800	1.60	➤ 460	1184	2.37
➤ 250	816	1.63	➤ 470	1204	2.41
➤ 260	832	1.66	➤ 480	1223	2.45
➤ 270	848	1.70	➤ 490	1243	2.49
➤ 280	864	1.73	➤ 500	1263	2.53

NOTE

Probe is factory checked at 350 °F. Must be completely disconnected from circuit board when measuring probe resistance. Display will read "HELP" if probe is open or unplugged. Any probe resistance can be multiplied by 2 milli-amps (.002) to determine voltage drop.

EHS-C MODEL STRAPPING

The Front Control panel of the Lang "Purple" computer must be configured to match the model of oven it is being installed in. To configure the front control panel, you must change the arrangement of the **Strapping Bars** located at the bottom of the circuit board just above the ribbon connection. Each model has its own strapping configuration, which must be set by the service technician. Follow the diagram below for the proper strapping configuration.

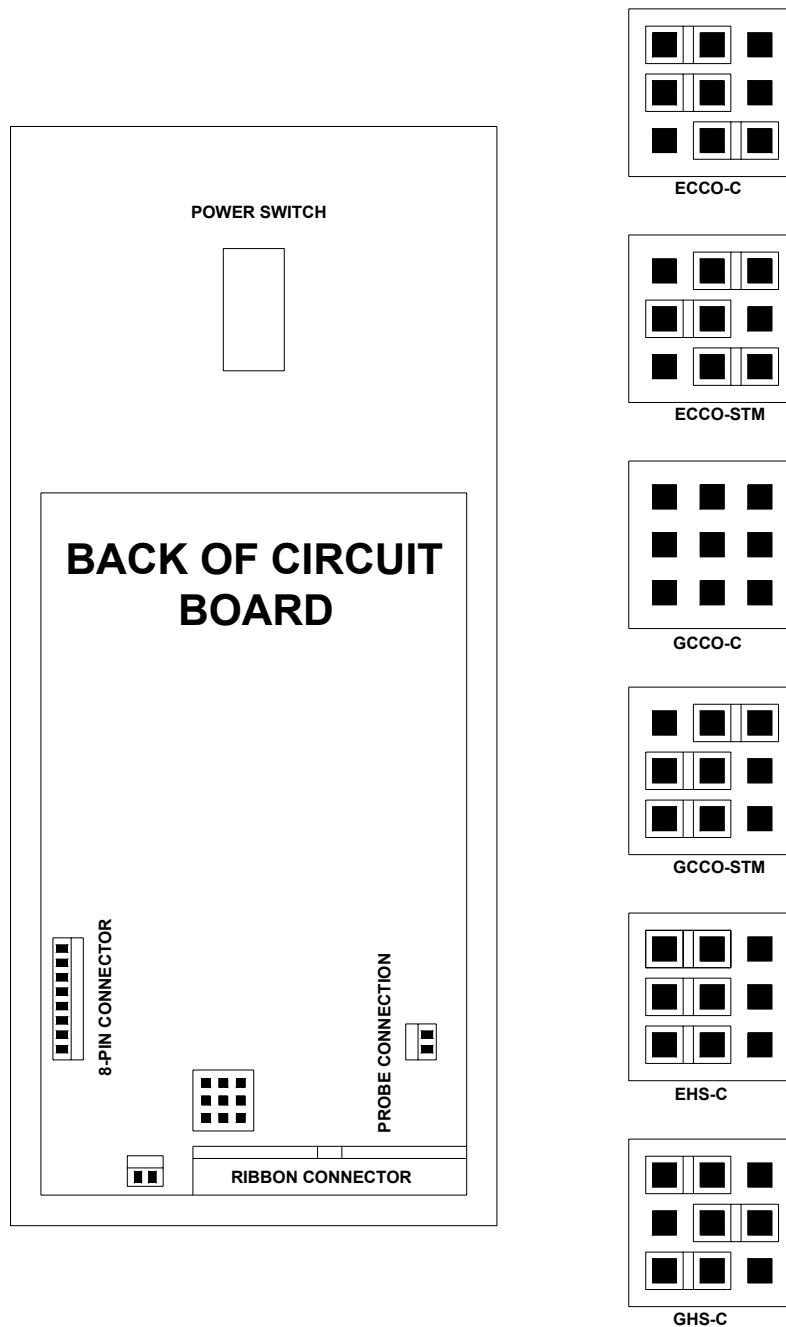

EHS-C TEST POINT LAYOUT

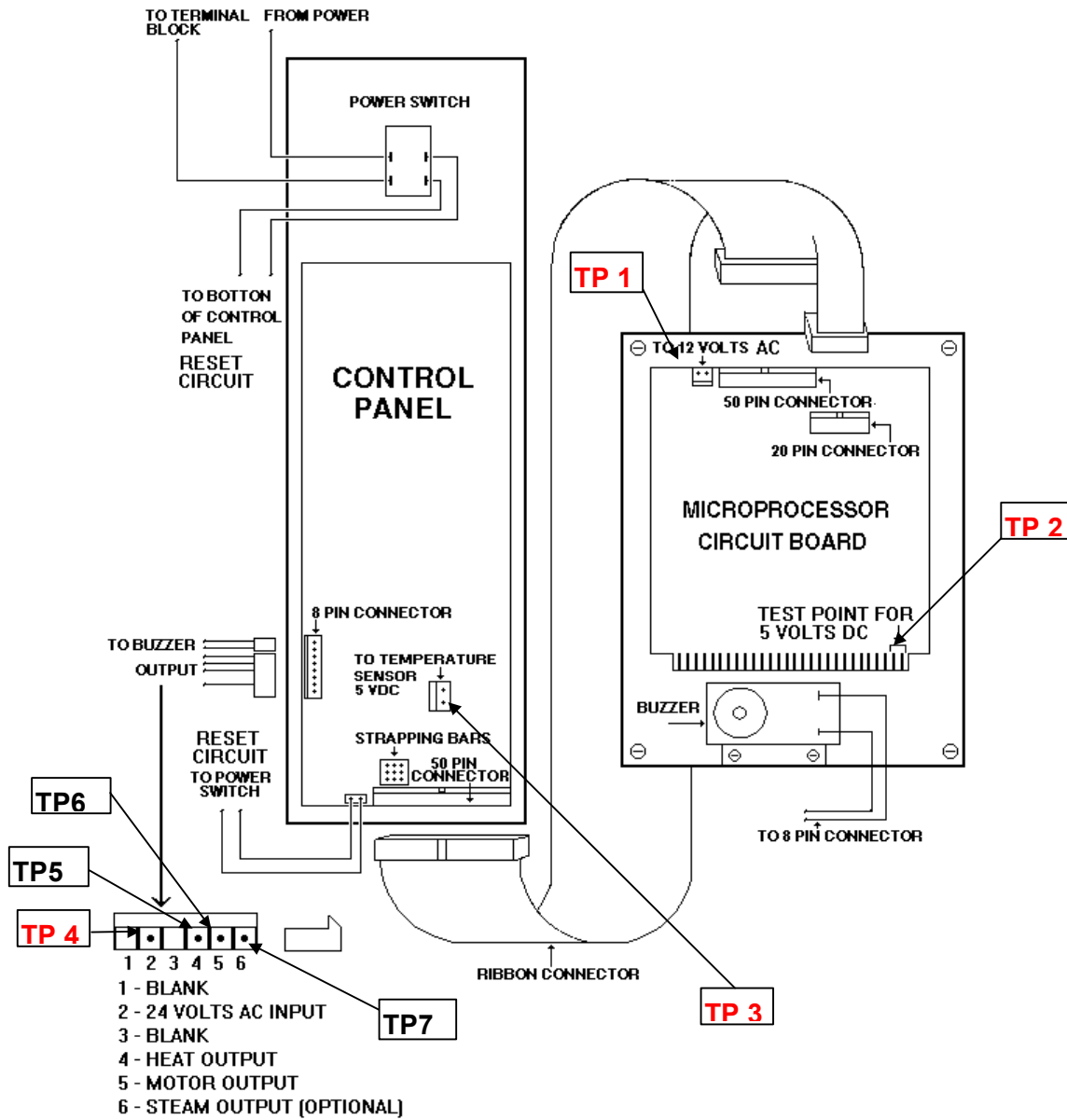

EHS-PP / -PT TEST POINT LAYOUT

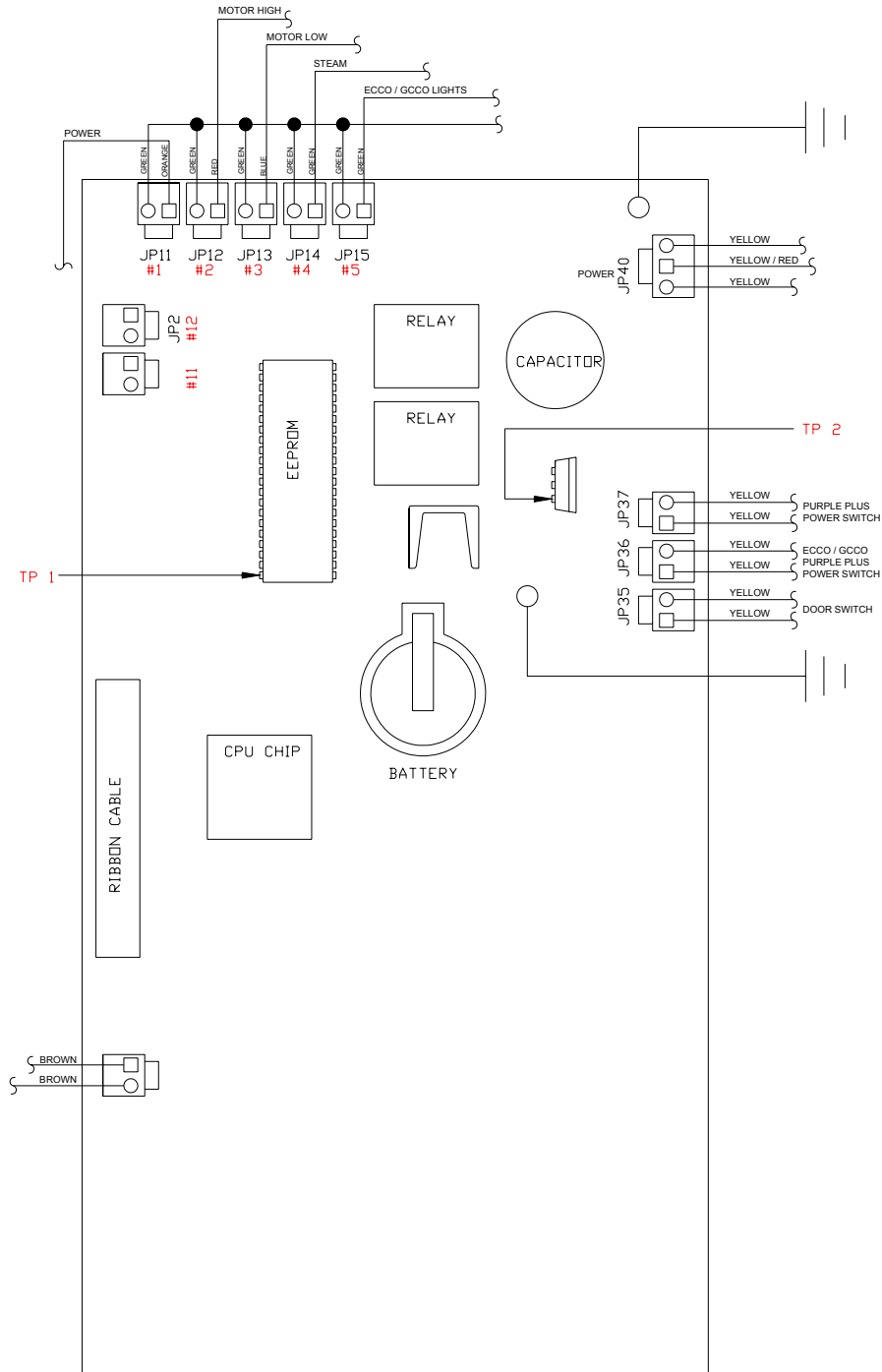

EHS-T 208/240 WIRING DIAGRAM

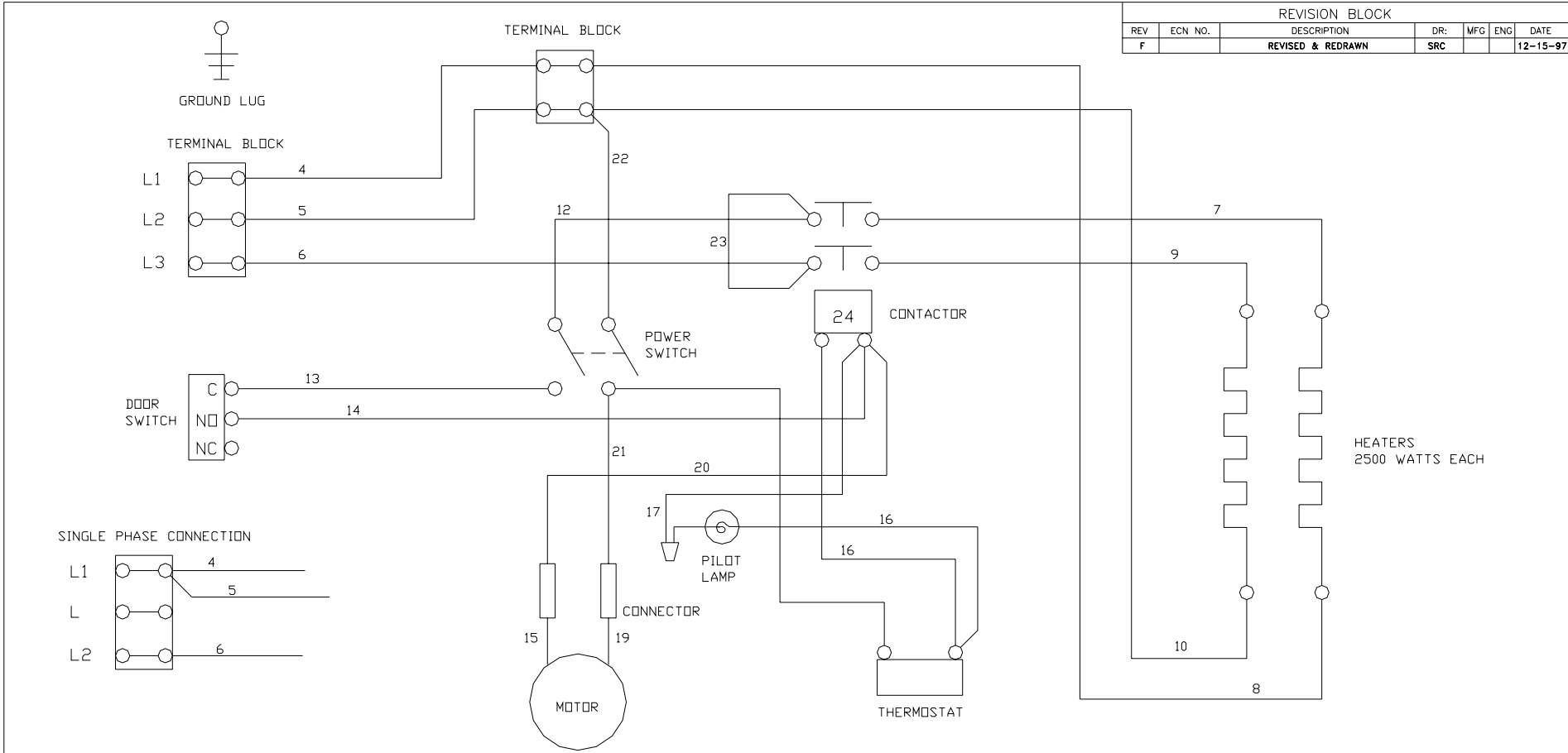

REVISION BLOCK						
REV	ECN NO.	DESCRIPTION	DR:	MFG	ENG	DATE
F		REVISED & REDRAWN	SRC			12-15-97

KW				AMPS							
				208V 3 PHASE			240V 3 PHASE			SINGLE PHASE	
L1-L2	L2-L3	L1-L3	TOTAL	L1	L2	L3	L1	L2	L3	208V	240V
0.0	3.1	2.5	5.6	12.0	14.9	23.3	10.4	12.9	20.2	26.9	23.3

QTY	ITEM	PART NUMBER	DESCRIPTION / MATERIAL									
LANG MANUFACTURING												
DR:	SRC	DATE: 12-15-97	TITLE: WIRING DIAGRAM									
CK:	DATE:											
EHS-T 208/240V 5.3 KW												
TOLERANCES			NEXT HIGHER ASSY.						SHEET	DRAWING NUMBER	REV	
FRACTIONS: ± 1/64			XX ± .03						DRAWING NUMBER		REV	
DECIMALS: ± .05			UNLESS OTHERWISE SPECIFIED						1 OF 1		61111-24	F
ANGLES: ± 5°			DIMENSIONS ARE IN INCHES									
SCALE: TO FIT												

EHS-AP 208/240 WIRING DIAGRAM

REVISION BLOCK									
REV	ECN NO.	DESCRIPTION				DR:	MFG	ENG	DATE
A		ADDED HIGH LIMIT DISC STAT				SRC			11-7-97

-AP
CONTROL

	VOLTS				KW				AMPS			
	L1-L2	L2-L3	L3-L1	TOTAL	L1	L2	L3	1 PH	L1	L2	L3	1 PH
EH	208	2.5	2.5	3.1	8.1	23.3	20.8	23.3	38.9			
EH	240	2.5	2.5	3.1	8.1	20.2	18.0	20.2	33.8			

SERVICE CONNECTIONS					
THREE PHASE			SINGLE PHASE		
L1	L2	L3	L1	L2	
1-4	2-5	3-6	1-3-5	2-4-6	

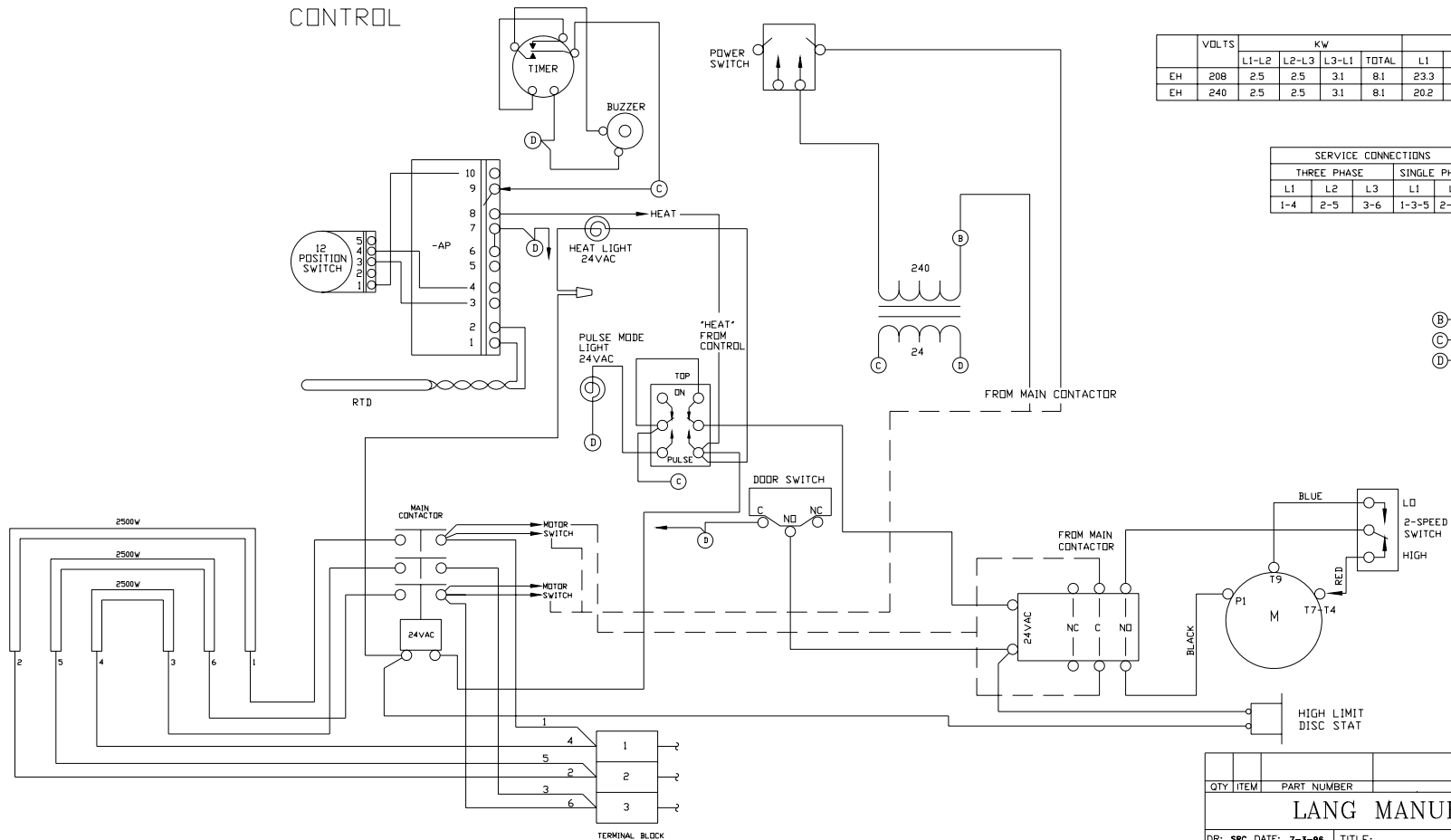
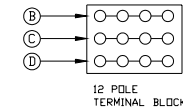

QTY	ITEM	PART NUMBER	DESCRIPTION / MATERIAL
LANG MANUFACTURING			
DR: SRC DATE: 7-3-96		TITLE: W/D EH-AP	
CK: FJD DATE: 7-3-96		208-240VAC	
<small>TOLERANCES</small> <small>FRACTIONS</small> ± 1/64 <small>DECIMALS</small> .XX ± .05 <small>ANGLES</small> ± .5° <small>UNLESS OTHERWISE SPECIFIED</small> <small>DIMENSIONS ARE IN INCHES</small>		NEXT HIGHER ASSY.	SHEET
SCALE: TO FIT		DRAWING NUMBER	REV
		1 OF 1	61111-135 A

EHS-C 208/240 WIRING DIAGRAM

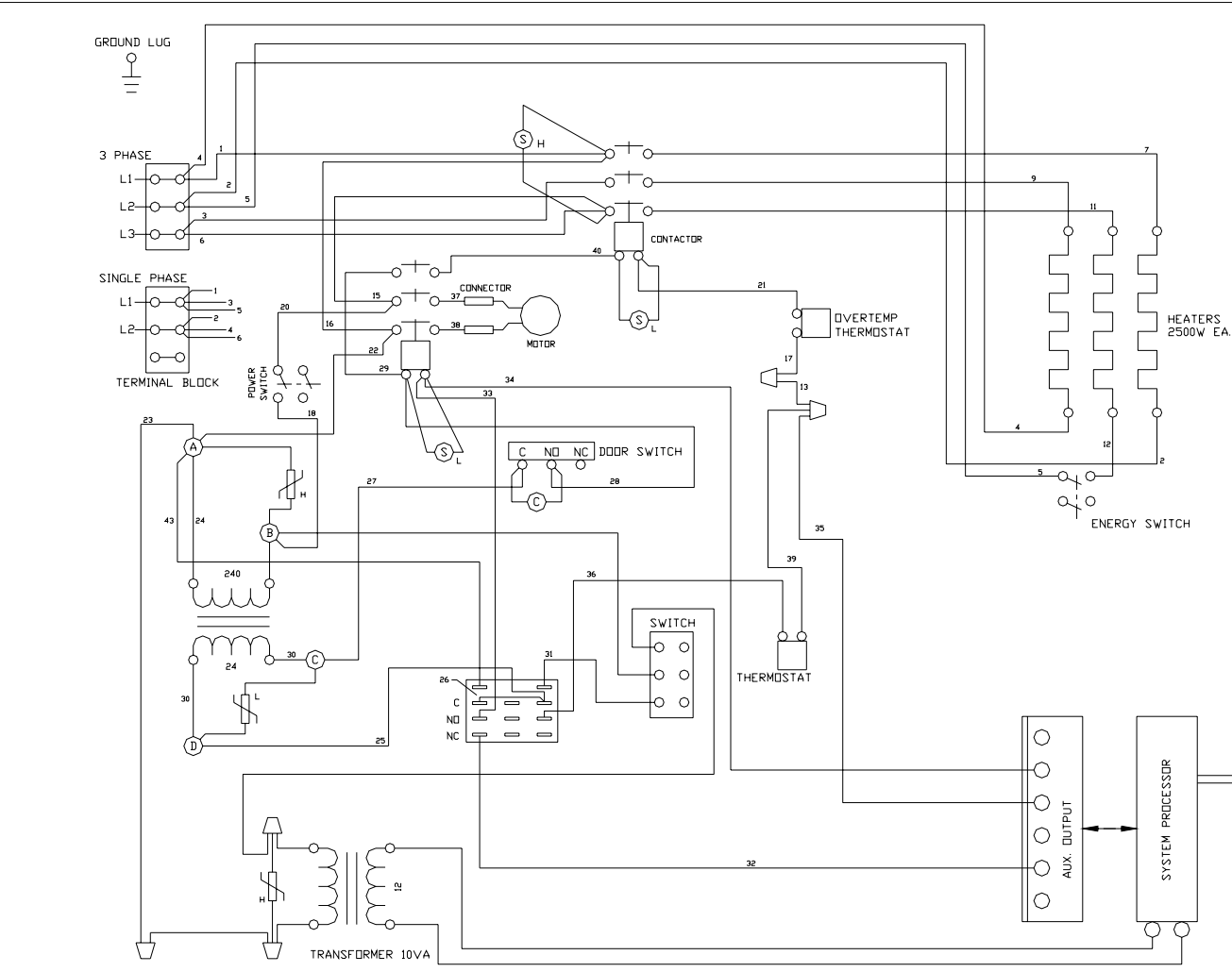

REVISION BLOCK						
REV	ECN NO.	DESCRIPTION	DR:	MFG	ENG	DATE
E		REMOVED SNUBBER	SRC			3-5-98

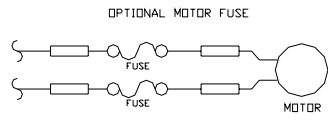

- S SNUBBER
- C CAPACITOR
- 47Z1
- ZHR14X431

KW				AMPS							
				208V 3 PHASE			240V 3 PHASE			SINGLE PHASE	
L1-L2	L2-L3	L3-L1	TOTAL	L1	L2	L3	L1	L2	L3	208V	240V
2.5	2.5	2.8	7.8	22.1			19.1			37.5	32.5

QTY		ITEM	PART NUMBER	DESCRIPTION / MATERIAL
WIRING DIAGRAM				
LANG MANUFACTURING				
DR: SRC DATE: 10-6-97		TITLE: EHS-C 208/240VAC		
CK: FJD DATE: 10-7-97				
TOLERANCES		WITH BACKUP THERMOSTAT		
FRACTIONS ± 1/64		DECIMALS .XX ± .03		
ANGLES ± .5°		UNLESS OTHERWISE SPECIFIED DIMENSIONS ARE IN INCHES		
SCALE: TO FIT		NEXT HIGHER ASSY.	SHEET 1 OF 1	DRAWING NUMBER 61111-39
				REV E

EHS-PP 208/240 WIRING DIAGRAM

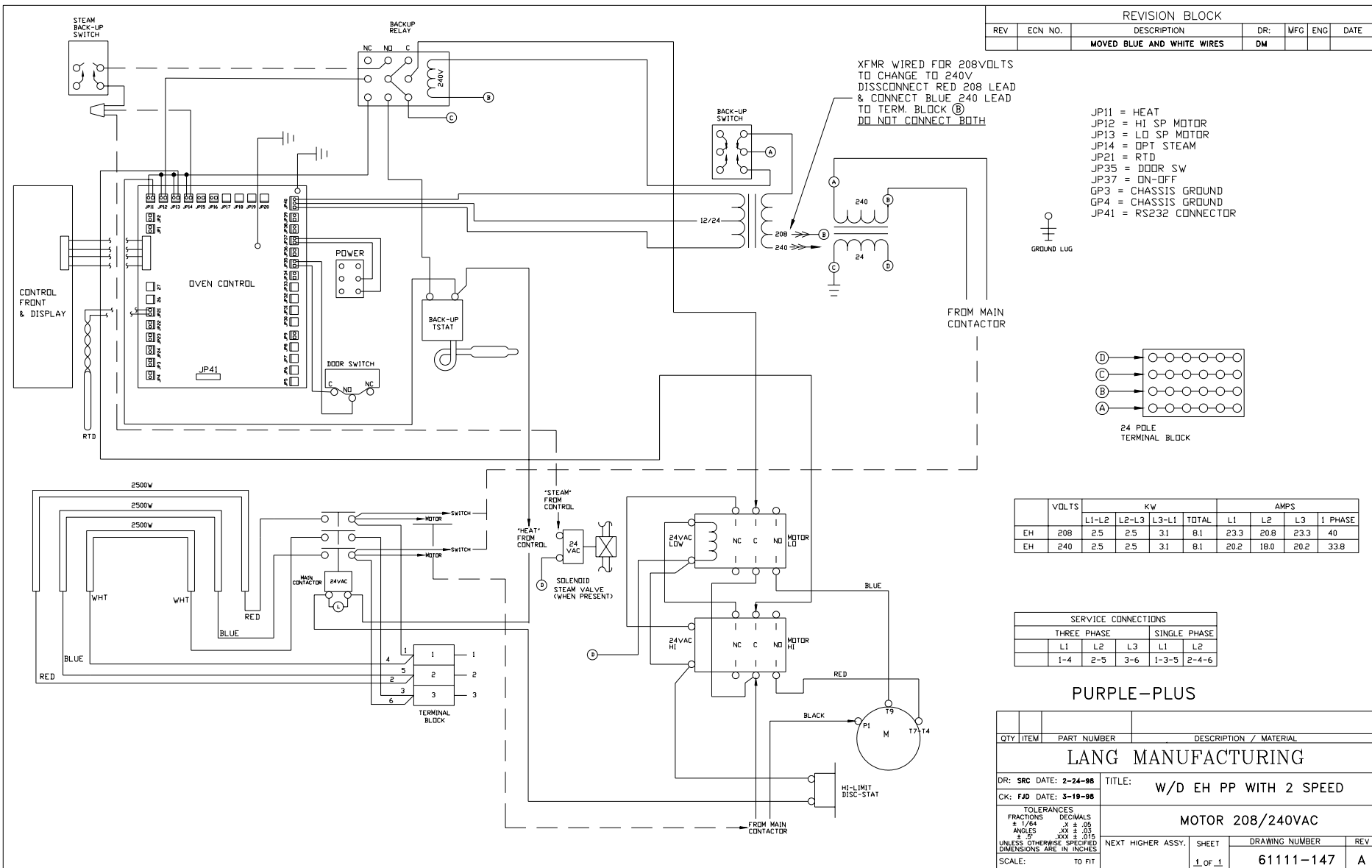

EHS-PP 480 WIRING DIAGRAM

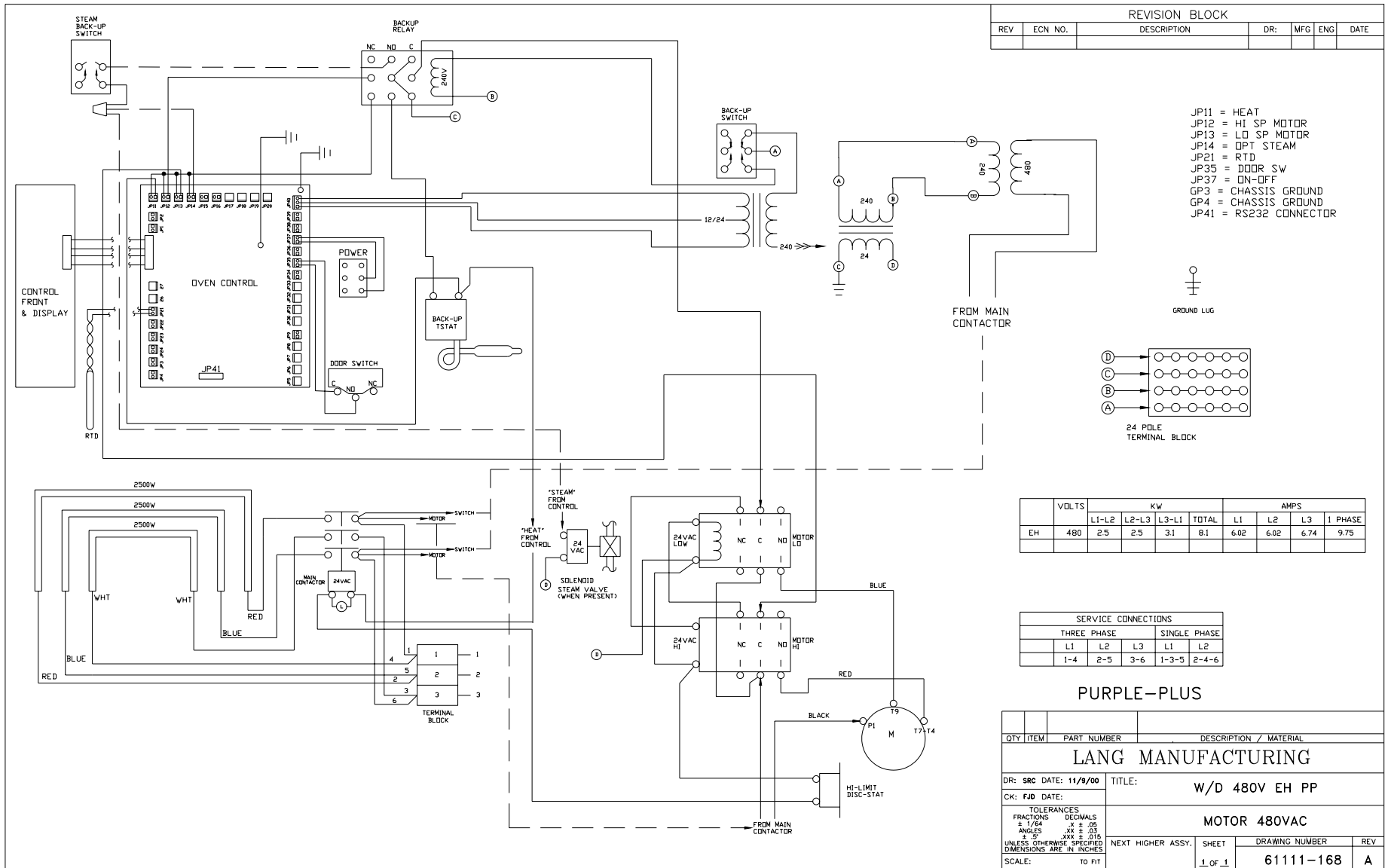

REVISION BLOCK						
REV	ECN NO.	DESCRIPTION	DR	MFG	ENG	DATE

- JP11 = HEAT
- JP12 = HI SP MOTOR
- JP13 = LD SP MOTOR
- JP14 = OPT STEAM
- JP21 = RTD
- JP35 = DOOR SW
- JP37 = ON-OFF
- GP3 = CHASSIS GROUND
- GP4 = CHASSIS GROUND
- JP41 = RS232 CONNECTOR

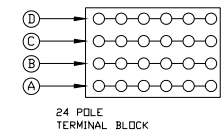

	VOLTS	KW			TOTAL	AMPS			
		L1-L2	L2-L3	L3-L1		L1	L2	L3	1 PHASE
EH	480	2.5	2.5	3.1	8.1	6.02	6.02	6.74	9.75

SERVICE CONNECTIONS					
THREE PHASE			SINGLE PHASE		
L1	L2	L3	L1	L2	
1-4	2-5	3-6	1-3-5	2-4-6	

PURPLE-PLUS

QTY	ITEM	PART NUMBER	DESCRIPTION / MATERIAL
LANG MANUFACTURING			
DR: SRC DATE: 11/9/00		TITLE: W/D 480V EH PP	
CK: FJD DATE:		MOTOR 480VAC	
TOLERANCES FRACTIONS DECIMALS ± 1/64 .X ± .05 ANGLES .XX ± .03 ± .5° .XX ± .015 UNLESS OTHERWISE SPECIFIED DIMENSIONS ARE IN INCHES		NEXT HIGHER ASSY.	SHEET
SCALE: TO FIT		1 OF 1	DRAWING NUMBER
			61111-168
			REV
			A

EHS-PT 480 WIRING DIAGRAM

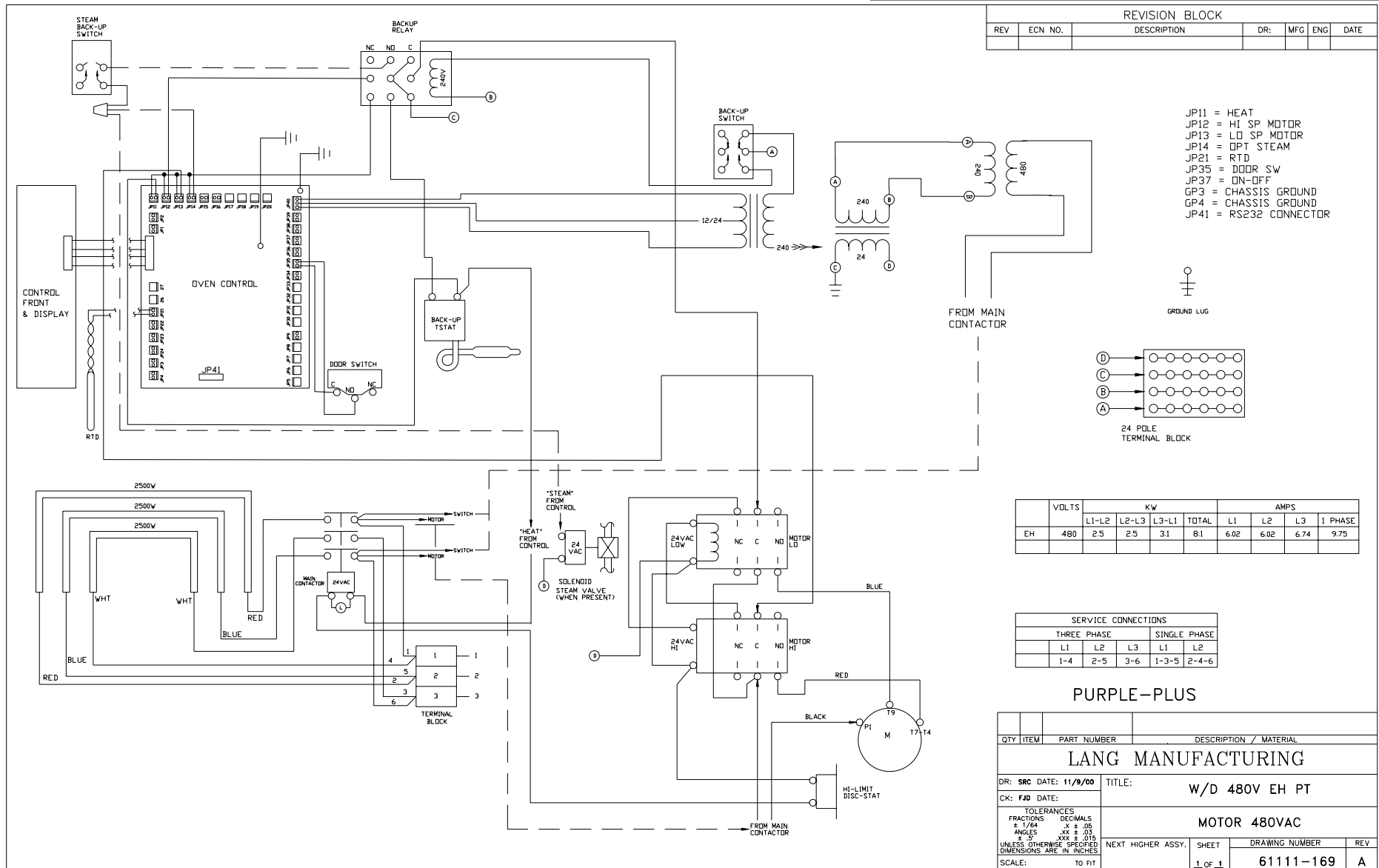

EHS-T PARTS LIST

DESCRIPTION	PART NO.
Element EHS Oven 208 Volt 5000 Watts	11090-23
Element EHS Oven 240 Volt 5000 Watts	11090-24
Stacking Pins	20108-01
Motor 1/3 HP 115/208/240 Volt	30200-12
Switch Toggle On-Off	30303-06
Thermostat Safety 490°F Open	60102-102
Thermostat 450°F Oven	30402-27
Terminal Block 3 Pole	30500-09
Contactor 3 Pole 208/240 VAC	30700-05
Contactor 2 Pole 208/240 VAC	30701-03
Timer Mechanical Long Ring	30801-01
Fuse 15 Amp	30900-10
Fuse Holder 15 Amp	30901-08
Pilot Light 208/240V 6" Lead Black Body	31601-01
Door Handle 11 1/2" Long Black "T" Style	50800-12
Complete Door Assembly	51100-53
Baffle	60101-621
Door Magnet	60102-147
Top Panel	60102-136
Rear Panel	60102-1361
Right Hand Panel	60102-1364
Switch, Plunger	60102-40
Switch, Plunger Oven Door (After V-27971 Except Reversible door)	30301-11
Switch Micro Convection Oven Door (Before V-27971)	51100-18
Door Seal	60102-97
Hinge Bracket Assembly, Upper and Lower	50313-030
Knob Manual Timer	70701-09
Knob Thermostat 450°F Oven	70701-16
Window Assembly, Oven Door	71301-04
Blower Wheel	71500-06
Rack	50200-34
Rack Slide	50200-83

EHS-AP PARTS LIST

DESCRIPTION	PART NO.
Element EHS Oven 208 Volt 7500 Watts	11090-20
Element EHS Oven 240 Volt 7500 Watts	11090-21
Element EHS Oven 480 Volt 7500 Watts	11090-22
Stacking Pins	20108-01
Motor 1/3 HP 480 Volt 2 Speed	30200-16
Motor 1/3 HP 208/240 Volt 2 Speed	30200-17
Switch Toggle On-Off	30303-06
Switch 12 Position	30304-16
Thermostat Safety 490°F Open	60102-102
Terminal Block 3 Pole	30501-02
Contactator 3 Pole 24 VAC	30700-06
Contactator 2 Pole 24 VAC	30701-05
Timer, Electric	30800-05
Buzzer, Electric Timer	30802-02
Transformer 480/240 VAC	31400-04
Transformer 120-208-240/24 VAC	31400-07
Pilot Light	31601-07
Circuit Board Temperature Control	40101-19
Probe Temperature Sensor	41100-12
Oven Rack	50200-34
Oven Rack Slide	50200-83
Door Handle 11 1/2" Long Black "T" Style	50800-12
Complete Door Assembly	51100-53
Baffle	60101-621
Door Magnet	60102-147
Top Panel	60102-136
Rear Panel	60102-1361
Right Hand Panel	60102-1364
Switch, Plunger	60102-40
Switch, Plunger Oven Door (After V-27971 Except Reversible door)	30301-11
Switch Micro Convection Oven Door (Before V-27971)	51100-18
Door Seal	60102-97
Panel Label	60301-25
Hinge Bracket Assembly, Upper and Lower	50313-030
Knob Time/Temperature Control	70701-28
Window Assembly, Oven Door	71301-04
Blower Wheel	71500-06

EHS-C PARTS LIST

DESCRIPTION	PART NO.
Element EHS Oven 208 Volt 7500 Watts	11090-20
Element EHS Oven 240 Volt 7500 Watts	11090-21
Element EHS Oven 480 Volt 7500 Watts	11090-22
Stacking Pins	20108-01
Motor 1/3 HP 480 Volt	30200-03
Motor 1/3 HP 115/208/240 Volt	30200-12
Switch Toggle On-Off	30303-06
Switch Toggle Spring Return	30303-16
Thermostat Safety 490°F Open	60102-102
Thermostat 450°F Oven	30402-27
Terminal Block 3 Pole (After D-70027)	30500-09
Terminal Block 24 Position Quick Disconnect (After D-70027)	30503-01
Relay 240 VAC	30600-02
Contactor 3 Pole 24 VAC	30700-06
Contactor 2 Pole 208/240 VAC	30701-03
Cable Ribbon Assembly (After D-70027)	31110-01
Transformer 480/240 VAC	31400-04
Transformer 120-208-240/24 VAC	31400-07
Transformer 240/12 VAC	31400-26
Circuit Board Assembly Buzzer (After D-70027)	40102-10
Circuit Board Front Panel (After D-70027)	40102-20
Circuit Board Microprocessor (After D-70027)	40102-44
Circuit Board Upgrade Kit (Before D-70027)	60101-53
Snubber Low Voltage On Coil, 3-Pole Contactor	40705-02
Snubber Hi Voltage Contactor Circuit Feed 208/240V	40705-04
Snubber Hi Voltage Across Poles, 3-Pole Contact 208/240V	40705-05
Snubber Low Voltage 24 Pole Terminal Block 480V	40705-08
Snubber Hi Voltage 24 Pole Terminal Block 480V	40705-09
Suppressor Low Voltage 24 Pole Terminal Block	40705-10
Suppressor Hi Voltage 24 Pole Terminal Block	40705-11
Probe Temperature Sensor	41100-12
Door Handle 11 1/2" Long Black "T" Style	50800-12
Complete Door Assembly	51100-53
Baffle	60101-621
Door Magnet	60102-147
Top Panel	60102-136
Rear Panel	60102-1361
Right Hand Panel	60102-1364
Switch, Plunger	60102-40
Switch, Plunger Oven Door (After V-27971 Except Reversible door)	30301-11
Switch Micro Convection Oven Door (Before V-27971)	51100-18
Door Seal	60102-97
Panel Label, Purple	60301-42
Panel Label, Braum's	60301-81
Hinge Bracket Assembly, Upper and Lower	50313-030
Knob Thermostat 450°F Oven	70701-19
Window Assembly, Oven Door	71301-04
Blower Wheel	71500-06
Rack	50200-34
Rack Slide	50200-83

EHS-PP PARTS LIST

DESCRIPTION	PART NO.
Element EHS Oven 208 Volt 7500 Watts	11090-20
Element EHS Oven 240 Volt 7500 Watts	11090-21
Element EHS Oven 480 Volt 7500 Watts	11090-22
Stacking Pins	20108-01
Motor 1/3 HP 480 Volt 2 Speed	30200-16
Motor 1/3 HP 208/240 Volt 2 Speed	30200-17
Switch Toggle On-Off	30303-06
Thermostat Safety 490°F Open	60102-102
Thermostat 450°F Oven	30402-27
Terminal Block 3 Pole	30500-09
Terminal Block 24 Position Quick Disconnect	30503-01
Relay 240 VAC	30600-02
Contactors 3 Pole 24 VAC (Heat)	30700-06
Contactors 2 Pole 24 VAC (Motor)	30701-05
Cable Ribbon Assembly	31110-13
Transformer 480/240 VAC	31400-04
Transformer 240/24 VAC	31400-10
Transformer 240/12 VAC	31400-26
Circuit Board Display	40102-24
Circuit Board Microprocessor	40102-26
Probe Temperature Sensor	41100-12
Oven Rack	50200-34
Oven Rack Slide	50200-67
Door Handle 11 1/2" Long Black "T" Style	50800-12
Complete Door Assembly	51100-53
Baffle	60101-621
Door Magnet	60102-147
Top Panel	60102-136
Rear Panel	60102-1361
Right Hand Panel	60102-1364
Switch, Plunger	60102-40
Switch, Plunger Oven Door (After V-27971 Except Reversible door)	30301-11
Switch Micro Convection Oven Door (Before V-27971)	51100-18
Door Seal	60102-97
Panel Label, Purple Plus	60101-7661
Hinge Bracket Assembly	50313-030
Knob Thermostat 450°F Oven	70701-28
Window Assembly, Oven Door	71301-04
Blower Wheel	71500-06
Wiring Harness, Element	EH-550
Wiring Harness, Power Switch	EH-554
Wiring Harness, High Voltage Control	EH-551
Wiring Harness, Low Voltage Control	EH-553

EHS-PT PARTS LIST

DESCRIPTION	PART NO.
Element EHS Oven 208 Volt 7500 Watts	11090-20
Element EHS Oven 240 Volt 7500 Watts	11090-21
Element EHS Oven 480 Volt 7500 Watts	11090-22
Stacking Pins	20108-01
Motor 1/3 HP 480 Volt 2 Speed	30200-16
Motor 1/3 HP 208/240 Volt 2 Speed	30200-17
Switch Toggle On-Off	30303-06
Thermostat Safety 490°F Open	60102-102
Thermostat 450°F Oven	30402-27
Terminal Block 3 Pole	30501-02
Terminal Block 24 Position Quick Disconnect	30503-01
Relay 240 VAC	30600-02
Contactors 3 Pole 24 VAC (Heat)	30700-06
Contactors 2 Pole 24 VAC (Motor)	30701-05
Cable Ribbon Assembly	31110-13
Transformer 480/240 VAC	31400-04
Transformer 240/24 VAC	31400-10
Transformer 240/12 VAC	31400-26
Circuit Board Display	40102-25
Circuit Board Microprocessor	40102-26
Probe Temperature Sensor	41100-12
Oven Rack	50200-34
Oven Rack Slide	50200-67
Door Handle 11 1/2" Long Black "T" Style	50800-12
Complete Door Assembly	51100-53
Baffle	60101-621
Door Magnet	60102-147
Top Panel	60102-136
Rear Panel	60102-1361
Right Hand Panel	60102-1364
Switch, Plunger	60102-40
Switch, Plunger Oven Door (After V-27971 Except Reversible door)	30301-11
Switch Micro Convection Oven Door (Before V-27971)	51100-18
Door Seal	60102-97
Panel Label, Purple Plus	60101-7662
Hinge Bracket Assembly, Upper and Lower	50313-030
Knob Thermostat 450°F Oven	70701-28
Window Assembly, Oven Door	71301-04
Blower Wheel	71500-06
Wiring Harness, Element	EH-550
Wiring Harness, Power Switch	EH-554
Wiring Harness, High Voltage Control	EH-551
Wiring Harness, Low Voltage Control	EH-553

THIS PAGE
INTENTIONALLY
LEFT BLANK