



800-292-3279 916 638-0828

<http://easycleansystems.com/heaters/heater-parts.html>

# VAL6

KBE5S and KBE5L

## Service manual



KBE5S



KBE5L

**Shizuoka Seiki Co., Ltd.**

## 1 Specifications

Type	VAL6 KBE5S
Heat Output	111,000BTU/h
Fuel	Kerosene, Diesel
Tank Capacity	9 gallons
Fuel Consumption	0.85gallon/h
Power Source	120V, 60Hz single phase
Power Consumption	80W (in burning), 100W (in igniting)
Ignition System	High Intensity Discharge
EXTERNAL DIMENSION (L/W/H)	27.4/27.9/36.2(in) [695/708/918(mm)]
Safety Device	Photocell Flame Monitor
Overload Check Device	3A Fuse
Dry Weight	83.8lbs

## 2 Names of Components

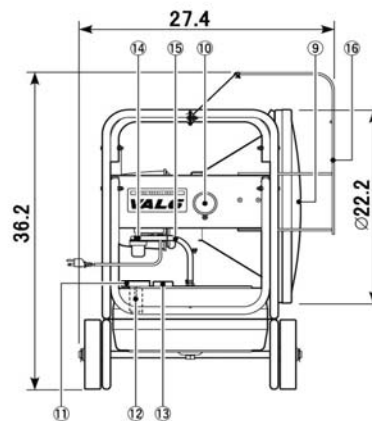
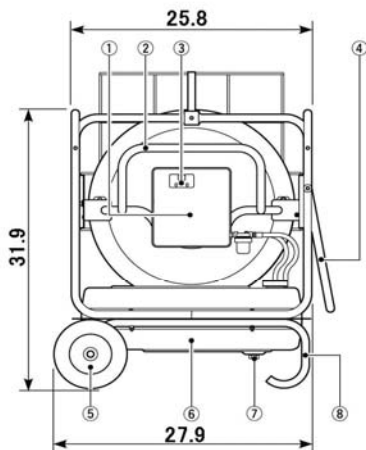

- ① Burner Cover
- ② Burner Handle
- ③ Switch Section
- ④ Transport Handle
- ⑤ Wheel
- ⑥ Fuel Tank
- ⑦ Drain Bolt
- ⑧ Tank Legs
- ⑨ Radiation Disk
- ⑩ Knob Bolt

- ⑪ Fuel Cap
- ⑫ Tank Inlet Filter
- ⑬ Fuel Gauge
- ⑭ Fuel Filter
- ⑮ Fuel Suction and Return Hoses
- ⑯ Protector
- ⑰ Flame Monitor (Flame Eye)
- ⑱ Fuse
- ⑲ Fan Motor

### ◆ Burner Section

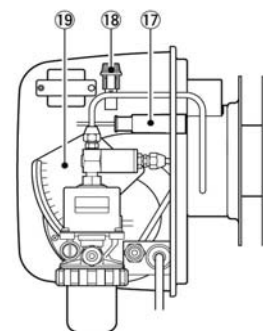

### ◆ Switch Section

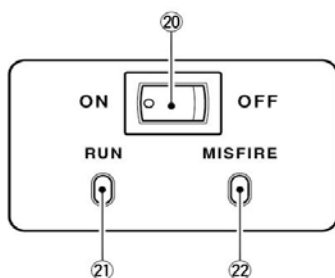

- ⑳ **Operating Switch**  
This ignites or extinguishes the flame.
- ㉑ **Operating Lamp**  
This is lit while (the heater is )operating and flashes while (the heater is) cooling down.
- ㉒ **Misfire Lamp**  
This flashes when the flame is extinguished.



## VAL6 KBE5S Troubleshooting

Phenomenon		page	
1	<b>The heater does not start</b>	The lamp does not light on	1
		Misfire lamp is lit	
2	<b>The heater does not ignite</b>	Fuel pump does not operate at all	3
		No fuel or a little fuel is pumped up	
		Igniter does not spark. [Igniter does not operate]	
		Sequence of operation is normal, but it doesn't ignite	
3	<b>Misfire within 25 seconds after ignition</b>	Misfire lamp is lit	5
4	<b>Combustion stop during the operation</b>	Misfire lamp is lit	6
5	<b>Odor comes out</b>		7
6	<b>Smoke comes out</b>		8
7	<b>Combustion is not stable</b>		9
8	<b>Fuel leaks</b>		
9	<b>Fuse blows out</b>	When the plug is put into the socket	10
		When the switch is turned on	
		About 5 seconds after turning on	

VAL6 KBE5S Trouble Shooting						
Phenomenon	Possible Cause	How to check	Result	Remedy	Reference	
<b>1. The heater does not start.</b>	<b>The lamp does not light on.</b>	No power source supplied	Measure voltage of AC outlet.	If circuit tester indicates 0V, power source is disconnected	Connect power source	
				Standard: AC120V		
		Fuse blowout	Take fuse out from fuse box, and then check each lead with circuit tester	If circuit tester reads $\infty$ $\Omega$ , fuse blows out	Find a cause of blown fuse and replace with a new one	Picture 8 Picture 9
		Disconnection of power cord	Take power source connector (CN 1) out from burner control, and then check each lead with circuit tester	If either of the lead is broken, power cord is broken	Make sure the power cord is connected, or replace it	
		Loose connection of power source connector	Plug in power source connector (CN 1) again, and then turn on	If it works normally, power source connector fails on contact	Plug in connector (CN 1) firmly	
		Loose connection of transformer connector	Plug in transformer connector (CN 7) again, and then turn on	If it works normally, transformer connector fails on contact	Plug in connector (CN 7) firmly	
		Failure of transformer	Measure voltage at output side of transformer connector (CN 7)	If tester reads normal voltage at input side, and reads 0V at output side, transformer fails	Replace transformer	
			Standard: about AC15V (purple-purple)			

<b>VAL6 KBE5S Trouble Shooting</b>						
<b>Phenomenon</b>	<b>Possible Cause</b>	<b>How to check</b>	<b>Result</b>	<b>Remedy</b>	<b>Reference</b>	
		Loose connection of operation switch connector	Plug in operation switch connector (CN 8) again, and then turn on	If it works normally, operation switch connector fails on contact	Plug in connector (CN 8) firmly	
		Failure of operation switch	Take operation switch connector (CN 8) out, then check lead with circuit tester	If it doesn't conduct when turned on, operation switch fails	Replace operation switch	
			Standard: Conducting (0 $\Omega$ ) when turned on			
		Failure of burner control	Measure voltage at input side of transformer connector (CN 7)	If power source is normal and tester reads 0V at input side, burner control fails	Replace burner control	
			Standard: AC120V (white-red)			
	<b>Run lamp is lit</b>	Loose terminals on control device	Firmly connect terminals for control device	If it works normally, terminals for control device are loose	Firmly connect terminals on control device	Picture 6
	<b>Misfire lamp is lit.</b>	Flame monitor sensor malfunctions	Unplug flame monitor connector (CN 11), and then start operation	It starts to operate	Avoid direct sunlight on radiation disk	
		Failure of burner control		It doesn't start to operate	Replace burner control	

<b>VAL6 KBE5S Trouble Shooting</b>					
<b>Phenomenon</b>	<b>Possible Cause</b>	<b>How to check</b>	<b>Result</b>	<b>Remedy</b>	<b>Reference</b>
<b>2. The heater does not ignite.</b>	<b>Fuel pump does not operate at all.</b>	Loose connection of fuel pump connector	Plug in fuel pump connector (CN 6) again, and turn on	If it works normally, fuel pump connector fails in contact	Plug in connector (CN 6) firmly
		Loose connection of joint connectors for fuel pump	Plug in joint connectors for fuel pump again, and then turn on	If it works normally, connectors on fuel pump fails in contact	Plug in Joint connectors firmly
		Failure of fuel pump	Measure voltage at output side of fuel pump connector on burner control	If voltage is normal, fuel pump fails	Replace fuel pump
		Failure of burner control	Standard: AC60~96V (red-blue)	If tester reads 0V, burner control fails	Replace burner control
	<b>No fuel or a little fuel is pumped up.</b>	Fuel line is clogged	Disconnect each fuel line, and then clean up each of them	If it ignites after cleaning, fuel flow decreases because of clogged in fuel lines	<ul style="list-style-type: none"> <li>• Clean fuel lines</li> <li>• Clean and rinse the tank with kerosene, alcohol or acetone</li> </ul>
		Filter is clogged	Check condition of filter	If filter is dirty, amount of fuel flow decreases because of clogged filter	<ul style="list-style-type: none"> <li>• Replace filter</li> <li>• Clean and rinse the tank with kerosene, alcohol or acetone</li> </ul>
		Nozzle is clogged	Replace nozzle	If it ignites, nozzle is clogged	<ul style="list-style-type: none"> <li>• Replace nozzle</li> <li>• Clean and rinse the tank with kerosene, alcohol or acetone</li> </ul>

<b>VAL6 KBE5S Trouble Shooting</b>					
<b>Phenomenon</b>	<b>Possible Cause</b>	<b>How to check</b>	<b>Result</b>	<b>Remedy</b>	<b>Reference</b>
	Loose joint of fuel lines	Check looseness of each joint	If heater ignites by tightening joints, air leak is the problem	Tighten joints	
	Fuel pump is clogged, or failure	Remove burner cover and fuel outlet line, and then turn on the switch	No fuel is pumped up, fuel pump is clogged or failure	Replace fuel pump	Picture 4
<b>Igniter does not spark. [Igniter does not operate.]</b>	Loose connection of igniter connector	Plug in igniter connector (CN 4) again, and then turn on the switch	If it works normally, loose connection of igniter connector	Plug in connector (CN 4) surely	
	Failure of igniter	Measure voltage at igniter connector (CN4) on burner control	If voltage is normal, igniter fails	Replace igniter	
	Failure of burner control	Standard:AC120V (black-black)	If tester reads 0V, burner control fails	Replace burner control	
<b>Sequence of operation is normal, but it doesn't ignite</b>	Electrode is out of alignment	Measure the alignment of electrode	Refer to Picture 5	Replace electrode (adjust the position)	Picture 5
	Improper amount of combustion air	Check gate opening of fan motor	Find adequate amount of air flow for better combustion	Adjust gate opening. Normal scale: 3	



<b>VAL6 KBE5S Trouble Shooting</b>						
<b>Phenomenon</b>	<b>Possible Cause</b>	<b>How to check</b>	<b>Result</b>	<b>Remedy</b>	<b>Reference</b>	
<b>3. Misfire within 25 seconds after ignition.</b>	<b>Misfire lamp is lit.</b>	Loose flame monitor	Open burner cover, and check if the flame monitor is in	If flame monitor comes off, it doesn't work	Put in flame monitor firmly	
		Shortage of light sensed from flame	Take flame monitor out, and check condition of its lens	If photoreceptor is dirty, sensor becomes less sensitive.	Clean the sensor with soft cloth	
			Remove burner, and then check clarity of draft tube and vane	If draft tube or fan is dirty, it senses little light	Clean draft tube and whirl vane	Picture 8
			Check extent of combustion air inlet opening	If opening is too wide, flame is short because combustion air is too much	Decrease opening to reduce combustion air. Normal scale: 3	
		Loose connection of flame monitor	Plug flame monitor connector (CN 11) again, and then turn on	If it works normally, flame monitor connector fails on contact	Plug connector (CN 11) firmly	
		Failure of flame monitor	Unplug flame monitor connector (CN 11), and then check transition of resistance by changing quantity of light into flame monitor	If resistance doesn't change, flame monitor fails	Replace flame monitor	
		Nozzle clogged	Replace nozzle	If it ignited, nozzle is clogged	Replace nozzle	
		Filter clogged	Check clarity of filter	If filter is dirty, fuel flow decreases because of filter clogged	Replace filter	

<b>VAL6 KBE5S Trouble Shooting</b>						
<b>Phenomenon</b>	<b>Possible Cause</b>	<b>How to check</b>	<b>Result</b>	<b>Remedy</b>	<b>Reference</b>	
<b>4. Combustion stops during</b>	<b>Misfire lamp is lit.</b>	Air leak	Check looseness of each joint	If heater ignites by tightening joints, air leak is the problem	Fasten joints more tightly	
		Insufficient amount of pumping fuel because vacuum forms in tank	Check if air intake of fuel gauge is clogged with dust	If air intake of fuel gauge is clogged, amount of fuel flow becomes insufficient because of vacuum	Clean air intake of fuel gauge	Picture 10
		Shortage of light detected by flame monitor	Take flame monitor out, and then check clarity of its lens	If lens of flame monitor is dirty, it detects a little light	Wipe lens of flame monitor with soft cloth	
			Remove burner, and then check clarity of draft tube and vane	If draft tube or whirl vane is dirty, flame monitor detects little	Clean draft tube and whirl vane	Picture 7
		Flame monitor connector is loose connection	Plug flame monitor connector (CN 11) again, and then turn on	If it works normally, flame monitor connector fails on contact	Plug connector (CN 11) firmly	
		Failure of flame monitor	Unplug flame monitor connector (CN 11), and then check transition of resistance by changing quantity of light into flame monitor	If resistance doesn't change, flame monitor fails	Replace flame monitor	
		Nozzle clogged	Replace nozzle	If it works normally, nozzle was clogged	Replace nozzle	
		Filter clogged	Check clarity of filter	If filter is dirty, fuel flow decreases because of clogged filter	Clean or replace filter	

<b>VAL6 KBE5S Trouble Shooting</b>					
<b>Phenomenon</b>	<b>Possible Cause</b>	<b>How to check</b>	<b>Result</b>	<b>Remedy</b>	<b>Reference</b>
<b>5. Smell of fuel comes out.</b>	Quantity of combustion air is too much	Check gate opening of combustion air inlet	If opening is too extensive, it burns imperfectly	Decrease gate opening of combustion air inlet. Normal scale: 3	
	Nozzle clogged	Replace nozzle	If it works normally, nozzle is clogged	Replace nozzle	
	Filter clogged	Check condition of filter	If filter is dirty, amount of fuel flow decreases because of clogged filter	Replace filter	
	Wrong nozzle	Check makers imprint of the nozzle Mark: 0.85USgal/h 60° H	If makers imprint is incorrect, the nozzle is should not be used	Replace to a correct nozzle	

<b>VAL6 KBE5S Trouble Shooting</b>					
<b>Phenomenon</b>	<b>Possible Cause</b>	<b>How to check</b>	<b>Result</b>	<b>Remedy</b>	<b>Reference</b>
<b>6. Smoke comes out.</b>	Shortage of combustion air	Check extent of combustion air inlet opening	If combustion air inlet is too small, it burns in short of oxygen	Extend combustion air inlet opening. Normal scale: 3	
	Decrease of air brought from fan	Check if fan is dusty	If fan is dusty, it is short of air	Clean fan	
	Decrease revolutions of the fan	Measure voltage at power source connector	If voltage at power source is lower than standard, combustion air is decreased because of low voltage	Check voltage	
	(Power source voltage is insufficient)	Standard: AC120V			
	Nozzle clogged	Replace nozzle	If it works normally, nozzle was clogged	Replace nozzle	
	Using at high altitude area (Low oxygen concentration)	Know the altitude	If using at higher than the altitude of 3300ft, heater burns imperfectly because of lack of oxygen	Extend combustion air inlet opening. Normal scale: 3	
	Wrong nozzle	Check makers imprint of the nozzle Mark: 0.85USgal/h 60° H	If makers imprint is incorrect, the nozzle is should not be used	Replace to a correct nozzle	

<b>VAL6 KBE5S Trouble Shooting</b>					
<b>Phenomenon</b>	<b>Possible Cause</b>	<b>How to check</b>	<b>Result</b>	<b>Remedy</b>	<b>Reference</b>
<b>7. Combustion is not stable.</b>	Loose joints in fuel line	Check looseness of each joint	If any joints are loose, air is absorbed into fuel lines from loose joint	Tighten joints	
<b>8. Fuel leaks.</b>	Loose joints in fuel line	Check looseness of each joint	If any joint is loose, fuel is leaking	Tighten joints	
	Failure of drain gasket	Remove drain bolt after removing fuel from tank, and then check that gasket isn't broken	Fuel leaks because of broken gasket	Replace drain gasket	
	Amount of fuel in the tank is too much	Check the fuel level	Fuel overflows because quantity of fuel in the tank is too much	Drain excess fuel	

VAL6 KBE5S Trouble Shooting					
Phenomenon	Possible Cause	How to check	Result	Remedy	Reference
<b>9. Fuse blows out</b>	<b>When the plug is put into the outlet.</b>	Short circuit of transformer coil	Unplug transformer connector (CN 7) from burner controller, then measure coil resistance values of two leads	If either of the values is 0Ω, transformer is short-circuited	Replace a transformer
			Standard: about 350Ω (white-red) Standard: about 9Ω (purple-purple)		
			<b>▪ Without tester</b>		
			Unplug transformer connector (CN 7) from burner controller, then put plug into AC outlet	If fuse doesn't blow out, transformer is short-circuited	Replace transformer
	<b>When the switch is turned on.</b>	Short circuit of fan coil	Unplug fan connector (CN 3) from burner controller, then measure resistance between terminals	If resistance value is 0Ω, fan coil is short-circuited	Replace fan
			<b>▪ Without tester</b>		
			Unplug fan connector (CN 3), and then start operation	If fuse doesn't blow out, fan coil is short-circuited	Replace fan

VAL6 KBE5S Trouble Shooting					
Phenomenon	Possible Cause	How to check	Result	Remedy	Reference
	Short circuit of igniter	Unplug igniter connector(CN 4) from burner controller, then measure resistance between terminals	If resistance value is 0Ω, primary side of igniter is short-circuited	Replace igniter	
		▪ Without tester			
		Unplug connector (CN 4) from igniter, and then start operation	If fuse doesn't blow out, igniter is short-circuited	Replace igniter	
About 5 seconds after turning on	Short circuit of pump coil	Unplug fuel pump connector (CN 6) from burner controller, then measure resistance between terminals	If resistance value is 0Ω, pump coil is short-circuited	Replace fuel pump	
		▪ Without tester			
		Unplug fuel pump connector (CN 6), then turn on	If fuse doesn't blow out, pump coil is short-circuited	Replace fuel pump	

**Chart1** Standard resistance of functional parts

Parts	Connector No	Lead	Condition	Resistance	Remarks
Operation Switch	CN8	Yellow—Yellow	on	0 Ω	
			off	∞ Ω	
Photo Cell	CN11	Black—Black	dark	over 2M Ω	
			light	under 10K Ω	
Transformer	CN7	Red—White	input	about 350 Ω	
		Purple—Purple	output	about 9 Ω	
Igniter	CN4	Black—Black	input	—	
			output	about 4.5K Ω	
Solenoid Pump	CN6	Red—Blue	—	about 130 Ω	
Fan motor	CN3	Gray—Gray	—	about 10 Ω	gate : Normal scale 3 (60Hz)*

When heater is used above 3,000ft sea level, adjust air inlet on fan motor for better combustion

**Chart2** Input & Output of Burner Control

Parts	Connector No	Lead	Condition	Voltage
Power code	CN1	Black—White	—	AC 120V (±10%)
Transformer	CN7	Red—White	input	AC 120V (±10%)
		Purple—Purple	output	about AC 15V
Igniter	CN4	Black—Black	input	AC 120V (±10%)
Solenoid Pump	CN6	Red—Blue	—	AC 60~96V
Fan motor	CN3	Gray—Gray	60Hz	AC 120V (±10%)
			50Hz	—



### Picture 1 How to measure resistance

- ① Pull out a connector which you will measure from burner
- ② Turn on the resistor and set resistor range
- ③ Insert the lead head of resistor to connector [lead wire side] and measure resistance



### Picture 2 How to measure voltage

- ① Operate the heater
- ② Turn on the resistor and set AC voltage range
- ③ Insert the lead head of resistor to connector and measure resistance

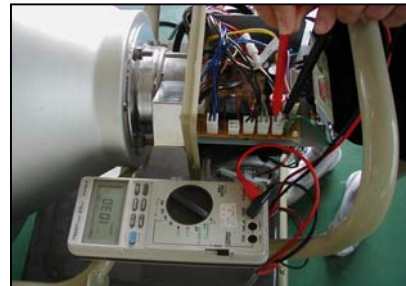

### Picture 3 Removing a burner



screw  
Unscrew two screws and take a burner cover off

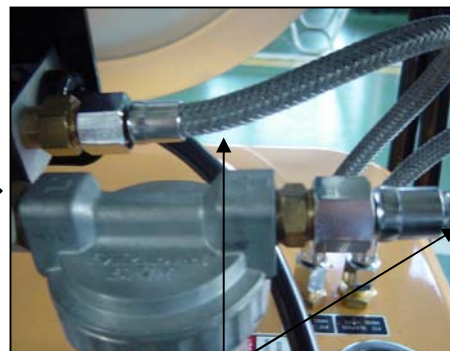

Unscrew two silver nuts with holding gold nuts and remove two fuel hoses

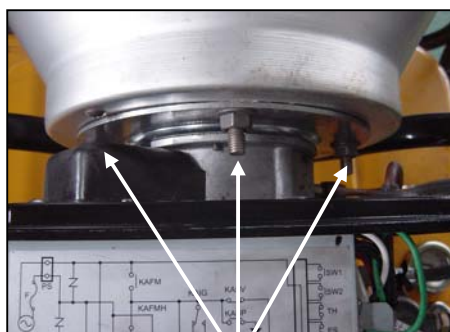

Nut  
Unscrew three nuts and take a burner off



**Picture 4 Inspection fuel pump**

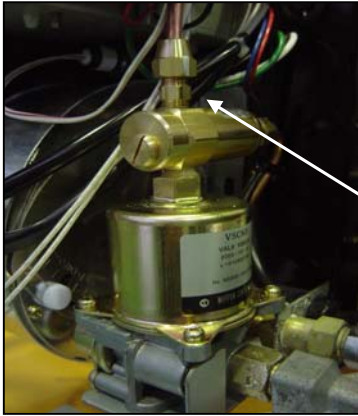

Remove a pipe and check whether fuel comes out

**Standard pressure 99 psi ( $\pm 4$ )**

**Picture 5 Standard position of electrode**

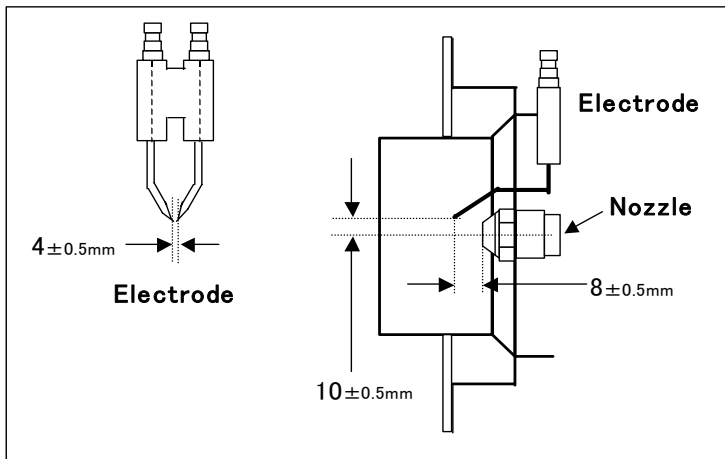

Manufacturer does not recommend to fix electrode as they are very sensitive to position.

**Picture 6 Inspection terminals for control device**

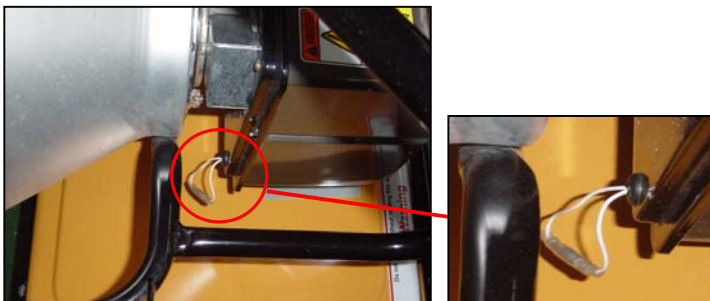

Check whether the terminals for control device are coupled firmly

**Picture 7 Inspection draft tube and fan**

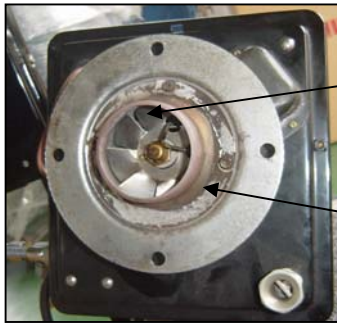

In case of draft tube and fan are dusty, please clean them up

**Picture 8 Inspection fuse①**

Object Serial Number : 01S, 01R, 01Q-030000



Open the fuse box and check whether the fuse blows out

**Picture 9 Inspection fuse②**

Object Serial Number :01Q-040000, 01P, 01N

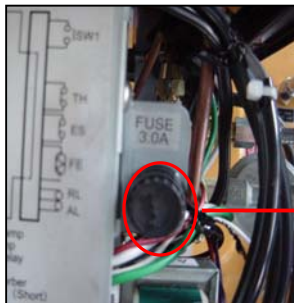

Open a screw cap and take out a fuse



Check whether fuse is blown out

**Picture 10 Clean up fuel gauge**

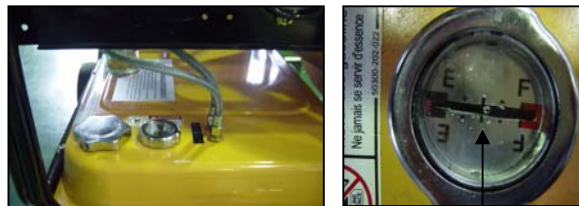

If air intake of fuel gauge is clogged, clean it up

..... **Daily Maintenance** .....

**■ Inspection of the tank inlet filter**

- 1 Remove the fuel cap and check inlet filter is clean
- 2 If the inlet filter is dirty, clean it with fuel
- 3 Place the inlet filter back and tighten the fuel cap firmly

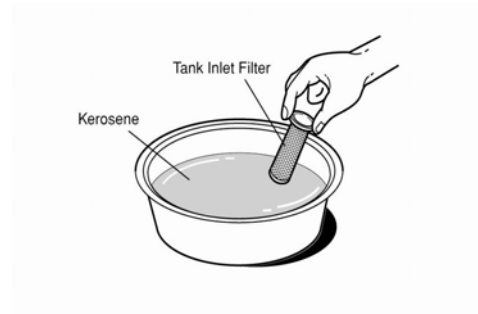

**■ Inspection of the filter and drainage of water from the fuel tank**

Checking the filter element

- 1 Check if the filter element is dirty
- 2 If the filter element is dirty, replace it with a new one. Plug the new filter in and tighten the metal ring
- 3 If dirt or water is found in the cup, clean the cup thoroughly. Also clean the inside of the fuel tank. Drain the dirty fuel from the bottom of the tank

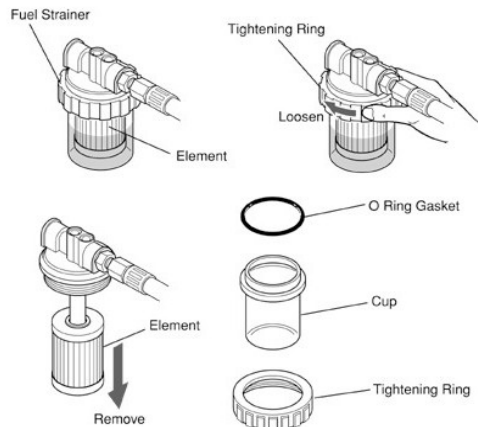

Drainage of water/dirty fuel from the fuel tank

- 1 Drain the old fuel from the bottom of the fuel tank by loosening the drain bolt
- 2 Place the drain bolt back
- 3 Pour clean kerosene or alcohol into the fuel tank
- 4 Shake the fuel tank
- 5 Loosen the drain bolt again to drain the dirty fuel
- 6 Place the drain bolt and fuel cap firmly

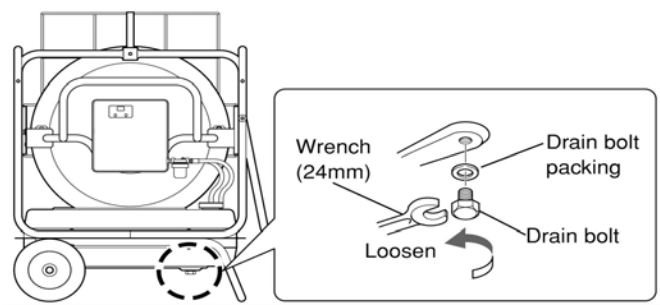

## ■ Inspection and cleaning of the flame monitor

**Observations** – When removing the flame monitor, hold it by its main assembly; do not pull out the cord.

- 1 Remove the burner cover and pull out the flame monitor, and check if sensor is dirty
- 2 If the sensor is dirty, please wipe the surface of its lens with a soft cloth
- 3 Place the sensor back into the position

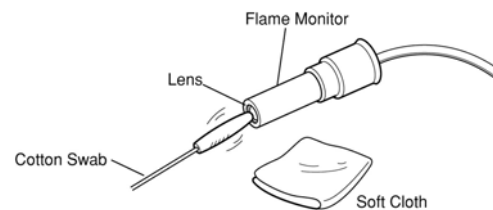
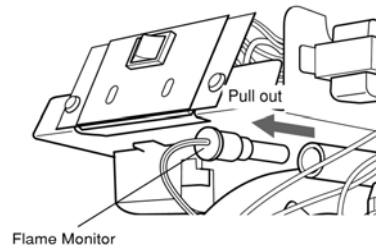

Online parts ordering: <http://easycleansystems.com/heaters/heater-parts.html>

Order parts by phone: 800 292-3279 916 638-0828

