

UDDER GUNtm

Model 15A

Operation and Service Manual



US Patent No. 9,072,274
Other Patents Pending

UG15A5-MAN-EN

Table of Contents

| | |
|--|----|
| Introduction..... | 4 |
| Safety | 6 |
| Installation | 8 |
| Operation..... | 11 |
| Daily Maintenance..... | 13 |
| Basic Service..... | 15 |
| Advanced Service | 20 |
| Prep Station | 20 |
| Spray Nozzle Service | 22 |
| Accessing the Gun Valve or Air Motor | 23 |
| Gun Valve Service..... | 24 |
| Air Motor Service | 26 |
| Flush Station Service..... | 28 |
| Troubleshooting..... | 30 |
| Parts List/Assembly Drawings..... | 34 |
| Warranty | 44 |

Introduction

Congratulations on your purchase of the Udder Gun System. To realize the full benefits of the udder gun, we encourage all people that will be operating, maintaining, and servicing this system to read this manual. Please visit our support page on our website www.uddergun.com. The support page has additional information, pictures and video to aid you in the use of your udder gun.

What It does

The Udder Gun System improves your milking efficiency by maximizing let down and shortening milking times. It allows your cows to be cleaned, prepped, and milked faster with it's specifically designed elastomer teat belts, which mimic a calf's natural suckling action, only much faster.

How It works

There are four main parts to the Udder Gun System: Prep Station, Primary hoses, Udder guns, and Flush stations.

The prep station is the unit usually mounted in the utility room. It uses incoming water and air pressure to mechanically mix water and sanitizing chemical to a desired ratio. Then it outputs this mix to the guns.

The primary hoses are used to deliver the water/chemical and air supply to the guns, from the prep station to the parlor.

The udder guns connect to the primary hoses and are the handheld devices that clean and stimulate the cows teats. The guns have air motors that use air pressure to power the teat belts. A two stage trigger activates both the air and the water/chemical spray.

The flush stations are mounted in the parlor and are used to holster the udder guns, and flush with fresh water when not being used.

What's Included In Systems

2 Gun System

(shown on page 5)

- (1x) Prep Station
- (2x) Udder Guns with 33' hosing
- (2x) Flush holsters w/ mounting hardware
- (1x) 50' Primary hose assembly
- (2x) 25' Primary hose assemblies
- (1x) Spare parts package
- (1x) English Manual

1 Gun System

- (1x) Prep Station
- (1x) Udder Gun with 33' hosing
- (1x) Flush holster w/ mounting hardware
- (1x) 50' Primary hose assembly
- (1x) 25' Primary hose assemblies
- (1x) Spare parts package
- (1x) English Manual

Introduction



Prep Station



Udder Gun w/ 33' hose



Udder Gun w/33' hose



50' Primary hose assembly



25' Primary hose assembly



25' Primary hose assembly



Spare parts package



Flush holster w/ mounting hardware

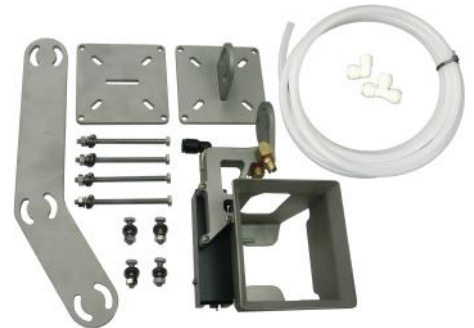

Flush holster w/ mounting hardware

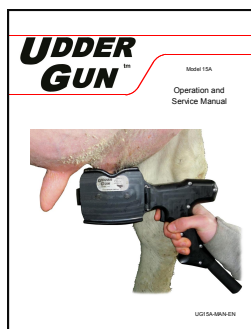

Udder Gun Manual

Safety

Anyone operating, maintaining, or servicing this system should read and understand this manual completely. Westar LLC will not be liable for damages or injuries caused by the use or misuse of the system.

The Udder Gun should only be used for its intended purpose and should be operated, maintained, and serviced properly by trained personnel for safety concerns and maximum working efficiency.

! WARNING Always wear safety glasses and proper personal protective equipment when operating, performing maintenance, or servicing the Udder Gun System.

! WARNING Do not run the gun onto a teat if the gun has worn out, broken, or completely missing teat belts, teat damage will occur.

! WARNING Do not run gun on teat with dry teat belts for more than 2 seconds, damage to teat may occur. Periodically check that an adequate amount of water/chemical is being sprayed onto the teat belts.

! WARNING Do not operate the system without covers and guards secured in place.

! WARNING Remove both air and water pressure before maintaining or servicing system.

! WARNING This system is built for speed and efficiency. Teat damage could occur if the gun is left running on a cow's teat longer than 3 seconds wet, or 2 seconds dry.

CAUTION Do not ingest, inhale, or get chemical in your eyes or on your skin. If this happens, clean or wash off immediately, and follow your safety warnings on your chemical's MSDS sheets. Westar is not liable for damages or injuries caused by third party chemicals.

CAUTION Wear appropriate clothing for the working environment to prevent loose articles of clothing from getting entangled in the gun or damaged.

CAUTION Do not have, carry, or wear any loose items which can become entangled or broken: i.e. watches, necklaces, bracelets, rings, cellphone, wallet, keys, long hair, baggy sleeves etc.

CAUTION The udder gun is for cleaning a cow's teat only. Do not stick foreign objects into Udder Gun, such as fingers, hands, hair, or other items.

CAUTION Operators should be aware that cows may kick while using the udder gun, damage to the gun or personal injury may occur if not used properly.

CAUTION The Udder Gun System should be inspected for proper working condition before and during use.

CAUTION Properly install and maintain system hosing at all times to minimize tripping or entanglement hazards.

CAUTION Properly train operators to obtain your desired level of cleaning, sanitizing, and stimulation.

CAUTION Do not set guns down where cows or people walk. If operators are not using the gun, it should be placed in the flush holsters.

CAUTION Do not use the Udder Gun to prod cows or their legs.

Installation



Only trained personnel should perform the installation of the Udder Gun System.

NOTICE: Pre plan the best positions and routing for all the system components.

Prep Station

- The prep station should be near an adequate fresh water and dry, compressed air source.
- It should be located near a drain that can accept chemicals.
- Air source needs to be dry, 90-100 psi at up to 16 cfm. A push lock fitting is provided for either .375" O.D. or .50" O.D. plastic tubing.
- Fresh water source should be 10-60 psi at 50°-100° F going into the prep station, 16 oz/min maximum flow. Inlet fitting is 1/2 NPT female.
- The prep station should be easily accessible for maintenance and around 4-5 feet off the floor.
- Prep station area should be heated so freezing doesn't occur. System will be damaged if it freezes.
- Inlet water and air line should be rated for the pressures they will be subjected to.
- Mount prep station using mounting holes with proper bolts/screws/anchors for the type of wall being mounted to.
- Secure all incoming lines and the priming discharge line. When the priming lever is opened the discharge line should flow into a drain or a suitable area on the floor.
- Insert chemical suction line into chemical container and set desired ratio, using the proper screw in metering tip. Suction hose should be secured over the metering tip using a band clamp.

Primary Hoses

- The primary hoses connect to the prep station, each other, and the gun hoses. Connect the black, larger tube to the Prep Station air outlet push lock fitting. Connect the smaller red tube to the water/chemical outlet fitting mounted to the gray block on the Prep Station.
- The hoses need to be fastened securely to the wall/ceiling/floor or existing installed piping but out of the way of normal daily operations. This is to prevent trip hazards, entanglement, or premature hose failure from damage.
- Depending on your utility room and parlor layout, the primary hoses may be configured in a variety of ways. (see page 9)

Sample Primary Hose Layouts

Included in System

1x - 50' Primary Hose
2x - 25' Primary Hose

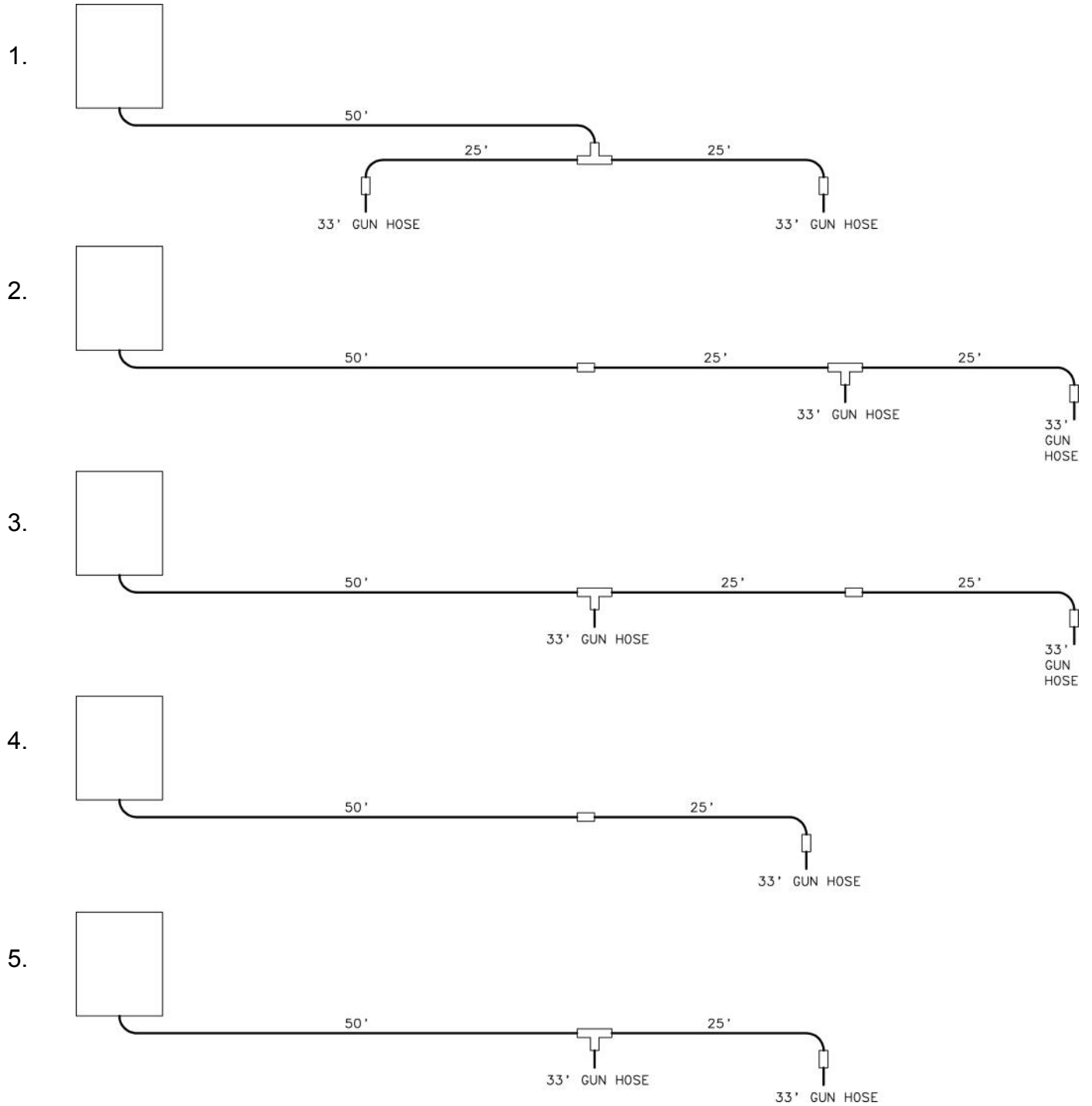

Installation

Gun Hose

- The gun hose is the one part of the system that can be left to drag across the parlor floor. It is designed to take daily abrasive abuse and being stepped on by personnel.
- Attach the hose end mounting brackets securely to either the wall, floor, or an existing pipe using the included mounting hardware. Position bracket so gun hose fittings can connect to the end of the primary hose or tee.
- Gun hose clamp block is pushed into the bracket and rotated.



Flush Holster

- The location of the flush holster's are just as important as the location of the prep station and should be preplanned for efficiency and ease of use.
- You will need a fresh water source running to each flush holster. Plan accordingly by placing them near a water line or somewhere that you could easily run a new water line to them. The inlet fitting on the flush valve is a push lock for .375" O.D. plastic tubing. 100' of .375" O.D. tubing is included, along with push lock fittings for installation.

CAUTION Run fresh water only through the flush holster, no chemical.

- Take into account the size of your parlor for worker efficiency. This will minimize the amount of walking back and forth to place the guns into the holster, after cleaning the cow's teats.
- The two most common positions are:
 - Both flush stations in the middle of the parlor
 - One flush station on either end of the parlor
- If you have multiple systems in one large parlor, staggering the flush stations down the parlor may be best.



Start Up

- Once your system is properly installed, you may begin the start up procedure.
- Place the chemical barrel near the prep station and insert the suction pick-up line into the chemical barrel.
- Open air valve to prep station and set the regulator to 90-100 psi.
- Turn on water to water inlet, making sure the pressure is between 10-60psi and temperature is 50°-100° F.



NOTE: With the prime lever open, water/chemical will flow out of the prime discharge hose, until the valve is closed.

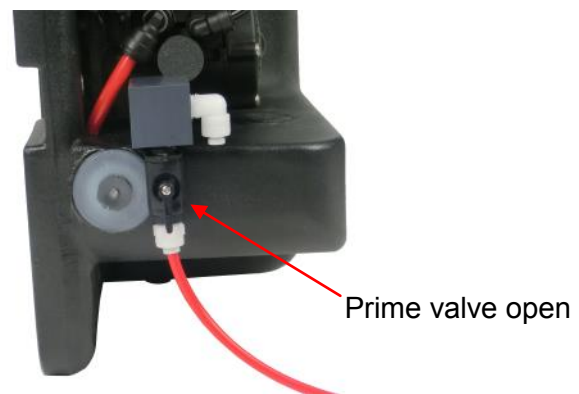
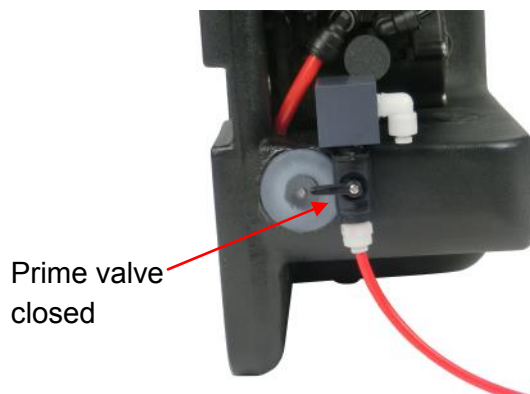

- Close the prime lever when you see chemical coming out the discharge hose.
- With the prep station primed, you may now pick up the Udder Gun and pull the trigger all the way back to allow air and water to flow through the gun.

NOTE: The trigger pull is in two stages, if you pull it part way, only the air will be on. You must pull it **completely** back to activate the water/chemical flow.

NOTE: Upon initial start up, the water/chemical may take a short time to run through all the hosing before it actually begins to spray out of the nozzle at the gun.

- Repeat the previous step for both Udder Guns, checking for teat belt motion and water/chemical flow.
- Insert the guns into the flush stations to check if the flush stations spray water and turn off in 5-20 seconds.

Operation

Teat Cleaning Procedure

- With your installation and initial start up completed, you can now begin cleaning and stimulating your cow's teats.
- Make sure the trigger is pulled back fully before moving the gun up onto the cow's teat.
- Between cleaning individual teats, the trigger should remain pulled with the gun running and spraying water. This allows the gun to self clean during the small amount of time between teats.
- Between cows, it is recommended to release the trigger so there is less chemical and compressed air waste.
- Continue this process for your remaining cows, making sure the gun is on before contact is made between the teat belts and teats, but off between cows.



NOTE: Leaking of water/chemical or foaming around gun grip is normal.

- If needed, you can dry more water off the teats using the two stage trigger. After cleaning all four teats with the trigger fully depressed, you can back off the trigger halfway and run the Udder Gun back around each of the four teats. The trigger at half position runs just the teat belts without water/chemical spray. Do not keep the udder gun running on a teat longer than two seconds using this mode.



Trigger at half

Teat Belts running only



Trigger back full

Teat Belts and water/chemical spray

CAUTION Each teat should only take a couple seconds before it's clean. Do not exceed three seconds per teat or you may damage the teats. If the belts are not cleaning fast enough, ask for maintenance to look it over for possible problems.

NOTE: When done using the Udder Guns, make sure they are inserted fully into the flush holster to wash out debris and keep the guns from being stepped on by workers or cows.

- The Udder Gun should be rinsed in the flush holster as often as possible (every 6-20 cows) to keep clean and prevent excessive wear.

Prep Station

- Check that incoming air is dry and at the correct pressure.
- If water is in the air filter bowl, loosen the bottom knob to drain out the water, then retighten.
- Check incoming water line for correct pressure.
- Check oil level in oil lubricator, fill accordingly with the attached funnel and recommended oil. (3-IN-ONE air tool oil)
- Make sure there are no visible leaks on any fitting/hose connection.
- Check the chemical ratio is where you want it for the particular chemical being used.
- Check that chemical is being drawn up the suction hose when the float valve turns the water on.

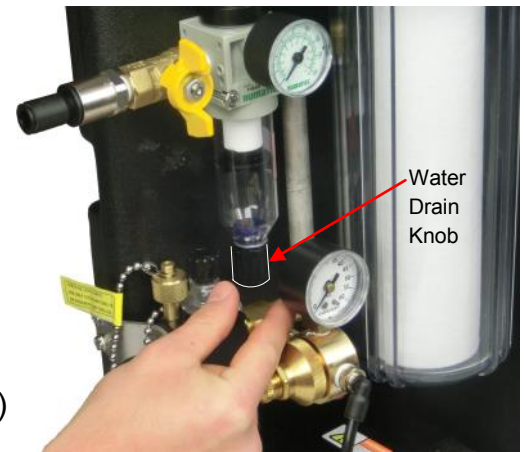

Primary Hoses and Gun Hoses

- Check hose couplers and push lock fittings for leaks.
- Make sure hoses are properly secured to the wall/ceiling/floor.
- Check that hoses are not trip hazards and will not entangle other machinery/people/cows.
- Look over hoses for leaks, excessive wear, or splitting.

Udder Guns

- Make sure guns are clean and free of debris before and after each shift.
- Open up all covers and look for wear or damage.

NOTE: Excessive wear will usually occur on the teat belt cover where the tracking clips are or around the spray nozzle slot on the main housing.

- With covers open, look over teat belts for wear on the ribs of the flaps or any broken off flaps.

NOTE: Teat belts are reversible to extend the life of the ribs and maintain short cleaning times.

- Look over the spindles to see if they still have a rough traction surface and check that they rotate freely, in their bearings.

NOTE: Rotating the spindle modules, to the other position weekly will extend the life of the spindles, module blocks and main housing.

Daily Maintenance

- Check tracking clips for wear and replace if needed.
- Make sure drive belts still have tension and traction on the pulleys.
- Take off drive belts and look over all five pulleys for excessive amounts of wear that could reduce traction.



Rotating Modules



Good Drive Pulley



Worn Drive Pulley

NOTE: A worn pulley will have the bottom of the groove look shiny and allow the drive belt to bottom out in the groove.

- Re-assemble the gun and test that the trigger functions correctly and that the air motor sounds up to speed.
- Check that the spray nozzle is spraying water/chem, the deflector is not clogged and the spray is fanned out properly.

Flush Station

- Check that the flush station brackets are all tightened and in the correct position.
- Insert a gun fully into the flush station to activate the valve and see that water sprays out.
- Make sure all three spray nozzles are spraying correctly and un-restricted.
- See that the flush stations turn off after being activated for 5-20 seconds.

Recommended Spare Parts

- Teat belts (611860)
- Drive belts (611850)
- Spindle modules (611938)
- Tracking clips (611760)
- Drive pulleys (611723)
- 3-IN-ONE air tool oil
- Pulley tool (611977)
- Splash shield (611766)

Basic Service Items

Teat Belts should be replaced or reversed whenever teat cleaning times increase and/or teats are not being cleaned well enough.

- They are easily replace by opening up the teat belt cover and by pulling on the flaps, working both sides back and forth until they come off. Reinstalling is just in reverse order.



To get more life from your Teat Belts

After running the Teat Belts a few days, they tend to stretch, this is normal. When they stretch to the point where they are slipping too much on good spindles, the set of Teat Belts should be replaced with different belts, then set aside the stretched belts.

After a few days, the stretched set of Teat Belts will shrink back closer to their original size and can be used again on the Udder Gun until their ribs are worn down on both sides.

Basic Service

Drive Belts should be replaced when they are overstretched and are losing traction to the drive or driven pulleys, but the pulleys are not worn out completely.

- To replace drive belts, remove the old ones simply by pulling them off by hand.
- Start the new belts by placing it around the drive pulley then work your way around, this will take some strength. Make sure the back belt is sitting in all the back pulley grooves and the front belt is in the front grooves.



Spindle Modules are designed to be replaced, for easy servicing.

- To replace a module, open up the teat belt cover and pull off the teat belts.
- Open up the drive belt cover and pull off drive belts, then pull out the slide pin. A pliers may help if the slide pin is stuck.
- Pull out the spindle modules and replace with new units.

NOTE: Pay attention to wear marks on the main housing where the spindle module's pads rest. You may need to flip the modules around to extend the life of the main housing. Also, be careful not to pinch off the spray nozzle hose, keeping it routed around the rear module.



Tracking Clips are essential to the function and preservation of the teat belt cover. It is worth replacing these often because they keep the teat belts centered, putting less load on the bearings and preventing the teat belt cover from wearing too quickly. You should replace these as soon as they are worn halfway through.

- To replace a tracking clip rotate, the old tracking clip a quarter turn in the direction allowed (one tracking clip gets rotated clockwise, the other gets rotated counterclockwise) and pull inward away from the cover, they should just pop out.
- Place new tracking clips in just like you took the old clips out, you should feel them snap into position when they are fully rotated horizontally.



Good Tracking Clip



Worn Tracking Clip

Drive Pulley should be replaced when it is losing traction to the drive belts. If it is worn, you will notice the bottom of the groove is shiny and smooth, indicating it needs to be replaced.

- To replace the pulley you need the pulley tool (P/N 611977). Insert the pins of the pulley tool into the two small holes on the pulley, then with the included 5/32 Allen wrench take off the button head screw holding the pulley to the output shaft.

Note: You must hold the pulley tool stationary and turn the Allen wrench counterclockwise to loosen the screw.

- With the screw out, you can pull off the pulley, but keep track of the 3/32 brass dowel pin key.

Note: A pulley might be corroded onto the output shaft. Two small flathead screwdrivers prying on either side of the pulley will help get it off.

- Slide the new pulley onto the shaft along with the small pin. Tighten the screw down to hold it in place using the pulley tool.



Basic Service

Splash Shield is mounted to the seat belt cover, with the purpose of reducing the amount of chemical/water being flung upwards and back towards the operator. If the splash shield is damaged or missing it needs to be replaced with a new one.



Air Tool Oil is needed to help lubricate the air motor and prevent it from rusting and seizing up.

- Turn off air pressure to the prep station.
- To fill the lubricator unscrew the knurled brass knob on the top left side of the lubricator.
- Insert the funnel attached to the chain into the hole where the brass knob was.
- Then fill funnel with 3-IN-ONE air tool oil checking the glass window on the side of the lubricator until it is about 3/4 of the way up the window.
- Wipe off remaining oil from the funnel and any that might have been spilled.
- Lastly thread the brass knob back into the fill hole making sure not to cross thread the hole and only tighten “finger tight”.
- There is an oil flow adjustment knob on the top of the lubricator. This should be set so there is one drop of oil going in every few minutes of running guns.

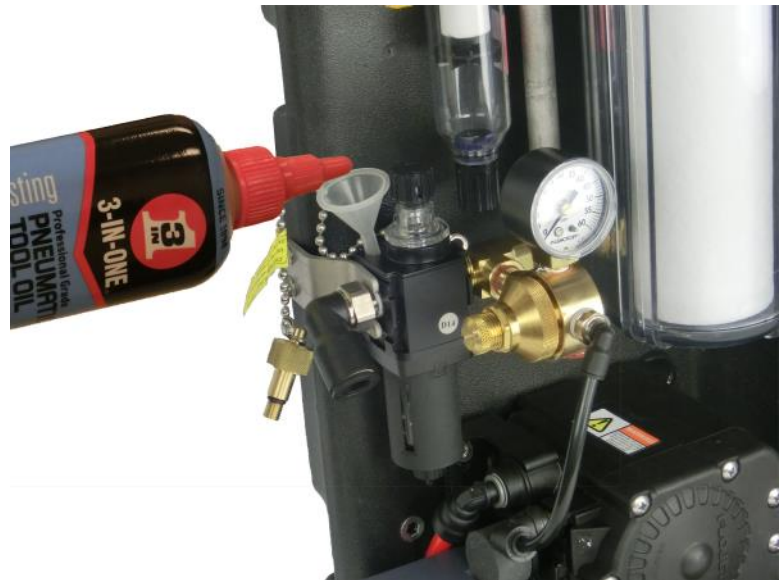

Advanced Service

Prep Station

 **CAUTION** Wear safety glasses and appropriate PPE when servicing.

 **WARNING** Turn off air and water. Run gun to dump remaining pressure before servicing.

Operation

The Prep Station uses incoming compressed air and water pressure for power. It then mixes water and chemical in batches, by passing water through an eductor which suctions chemical into the stream governed by a metering tip. When the lower reservoir is filled, the float turns off the water. An air driven pump sucks the water/chemical mix out of the reservoir and sends it out to the Udder Guns.

Servicing

- 1) Replace water filter cartridge as needed by unscrewing the clear bowl.
- 2) Water pressure regulator should be set to 25 psi.
- 3) Water float valve should turn off when float is up and turn on when float is down.
- 4) Main air pressure should be set between 90-100 psi. Drain air filter bowl daily by rotating knob on the bottom of the bowl.
- 5) Pump drive air pressure should be set to 25 psi.
- 6) Fill air lubricator through brass knob when needed. Use 3-IN-ONE air tool oil. Lubrication amount knob should be set to have 1 drop of oil for 15 min. of guns running.
- 7) If the pump does not work with water/chemical in the reservoir, air pressure to the pump and the prime lever open, it needs to be replaced.
- 8) Keep prime valve closed to send water/chemical to the guns.
- 9) Clean or descale metering tip or eductor if needed.

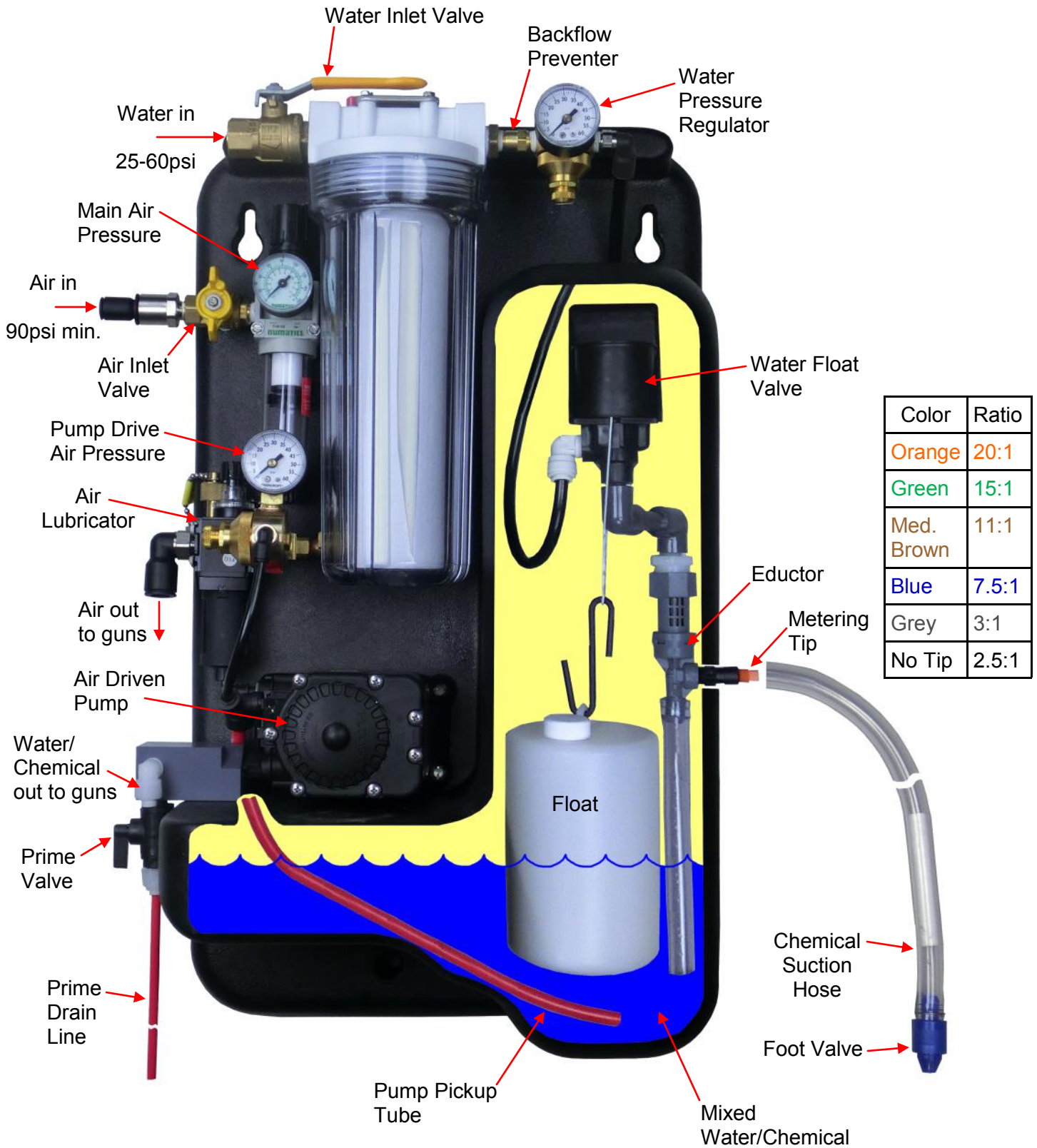

Advanced Service

Spray Nozzle Service

- 1) Open the drive belt cover and teat belt cover, remove the teat belts, drive belts and spindle modules.
- 2) Pull the spray nozzle hose off of the barb fitting.
- 3) Take out the two screws holding the spray nozzle to the main housing and check that the spray deflector is bent at approximately 60 degrees. The deflector should be bent so that the water stream hits it to fan out. If it is bent too little, the water fan will not exit the housing slot. If it is bent too much the water will not be fanned out at all.
- 4) Disconnect only the air line coupler on the gun hose, then pointing the spray nozzle hose in a safe direction, pull the trigger to allow water to flow out through the spray hose.
- 5) If water/chemical comes out, the clog is in the spray nozzle itself.
- 6) Unscrew the spray nozzle barb fitting and clean out the barb, or the spray nozzle jet. Blowing air back through the small jet hole usually works.
- 7) Reassemble the spray nozzle, attach hose and check that it sprays.

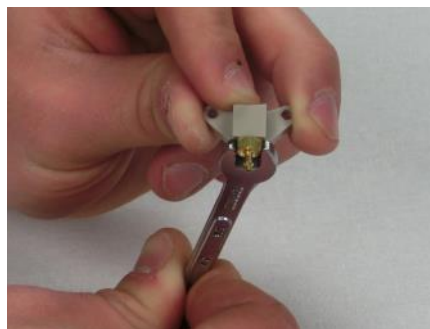

Accessing the Gun Valve or Air Motor

- 1) Take off teat belt cover by removing the e-clip on the hinge pin, then slide the pin out to remove the cover. Be careful not to lose the e-clip.
- 2) Remove all the housing screws (8x) and pull the grip half apart from the main housing.
- 3) Pull out the trigger and valve pins and set aside for safe keeping.
- 4) Take gun hose inlet block out of main housing.
- 5) Take off the clear, small diameter water hose from the barb on the valve using a small needle nose. This is the outlet hose that runs up to the nozzle.
- 6) Pull valve out from the housing and while holding the air motor and main housing in your left hand, pull the valve towards the front of the gun which should pull the air line off of the barb at the end of the air motor.

NOTE: This will take some force. It may be best to wear a glove on your right hand so you don't injure yourself when the hose "pops" off of the air motor barb.



Advanced Service

Gun Valve Service

- The valve controls both air and water/chemical in one valve body. The air valve and water valve are separate inside the valve body, each actuated by their own pin. The air valve has the larger barb fittings, the water side has the smaller barb fittings.
- 1) Disconnect the gun hose couplers (air and water) from primary hose.
 - 2) With the valve and gun hose assembly removed from the gun, inspect the valve pins for score marks and see that they move freely within the valve holes, if not replace them.
 - 3) Take off the back two screws holding the valve end plate on.
 - 4) Check the O-rings on the end plate for cracking or flat spots, replace if needed.
 - 5) Pull out the springs, see that they are not broken or bent, if so replace them.
 - 6) Check the stainless steel balls for wear or debris, replace if needed.
 - 7) Pull out the quad O-ring valve seats. Look for wear, cracks or debris, replace if needed.
 - 8) Reassemble the valve and gun in reverse order, hook up gun hose couplers and test.

NOTE: Use a small amount of oil on the end plate O-rings to help them slide into the valve body, without pinching or falling off their posts. Hold the back plate in position tightly, until at least one screw is in.

Advanced Service

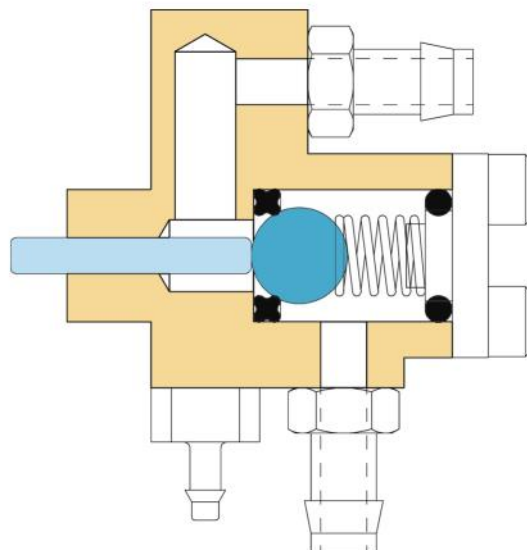
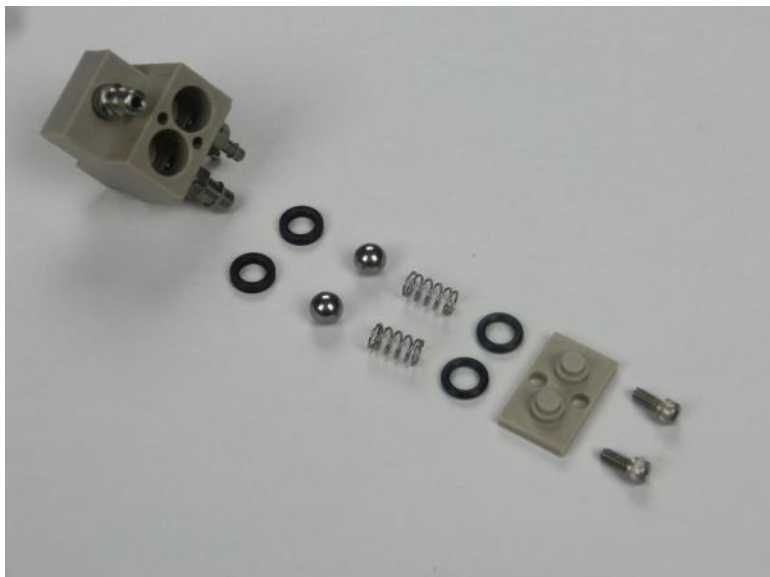
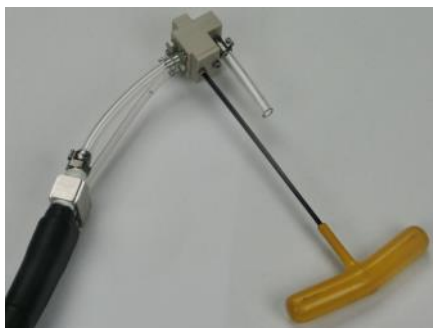

Advanced Service

Air Motor Service

- Air motor cells can lock up or lose power over time. The life of the air motor can be extended by not submerging the Udder Gun in water and by keeping oil in the airline lubricator.
- If the air motor does not work after replacing an air cell, ship unit back for factory service.

1) With the valve and gun hose assembly removed, you may now open the drive belt cover to gain access to the drive belts and drive pulley.

2) Take off the drive belts.

3) Remove the drive pulley using the pulley tool included in the service box.

NOTE: If needed, you can use two small flat head screwdrivers to pry on either side of the drive pulley to remove it once the screw is out. Also, do not lose the brass pin key.

4) Now lift out the air motor from the main housing.

5) Using the air motor tools (p/n 611978 & p/n 611979) provided in the service box, loosen the air motor end cap just enough so you are able to unscrew it by hand.

6) With the end cap loose, hold the air motor horizontal and begin unthreading.

7) Pull the end cap and air motor out and then pull the end cap off of the air motor cell. There are two pins on the air motor cell that friction fit into the end cap holes.

NOTE: Look at the orientation of the air cell and end cap, it will help during reassembly.

8) Place end cap onto the new air cell pins, keeping the orientation between the end cap barb fitting and the flat on the air cell the same as the old one was.

NOTE: If any washers pulled out with the old air cell, you will need to place them back in the motor tube correctly.

9) Slide the new air cell and end cap into the housing tube holding it horizontally, then begin threading the end cap in by hand. If while turning in, there becomes hard resistance, the air cell pinion gear is most likely not aligned or engaging with the planetary gears. To solve this, you must rotate the output shaft slightly to align the gears, then continue threading in the end cap.

10) With the end cap hand tight, you can now use the air motor tools to tighten just enough so that the end cap barb fitting is orientated 90 degrees clockwise to the gear motor output shaft when looking at it from the end cap side.

11) Reinstall the gear motor, push in the two muffler elements making sure not to pinch off the small, clear, spray nozzle hose.

12) Reassemble all remaining parts in reverse order.

Advanced Service

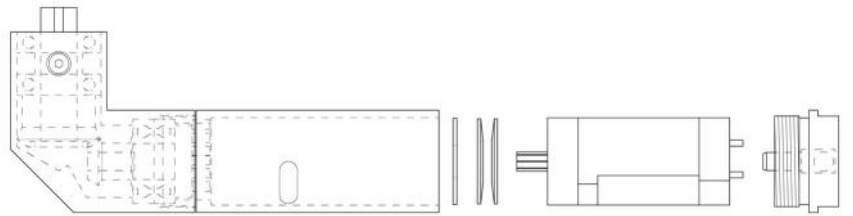
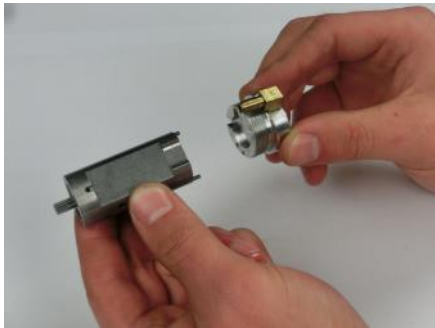
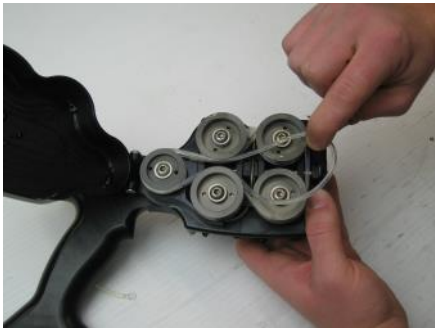

Advanced Service

Flush Station Service

- The flush station serves two purposes. It provides a holster to place the gun into when not using and it sprays water into the gun to flush out debris between uses.
 - When placing the gun into the holster, the gun activates a lever connected to the timed valve. Water spray will start, then turn off between 5-20 seconds, depending how the timer shock is adjusted.
 - The timer shock is an oil filled dampener. The rate of dampening is controlled by the adjustment knob. When the lever is pressed the whole shock moves towards the stem of the water valve. The shock stem, having stiff movement, pushes in the water valve stem. After some time, the water valve stem pushes the shock stem backwards enough that the water turns off.
- 1) If spray time is too short or too long, turn adjustment knob a small amount and test. Loosen the lock screw on the knob before moving the knob, lightly tighten lock screw after setting.
 - 2) If removing valve assembly from stainless frame, keep track of the O-ring that is between the two parts. Confirm that the O-ring is in the pocket of the valve block when reassembling.
 - 3) If the timer shock is screwed into the slide block too far, the water may not stop. If the shock is not far enough, that water may not start.

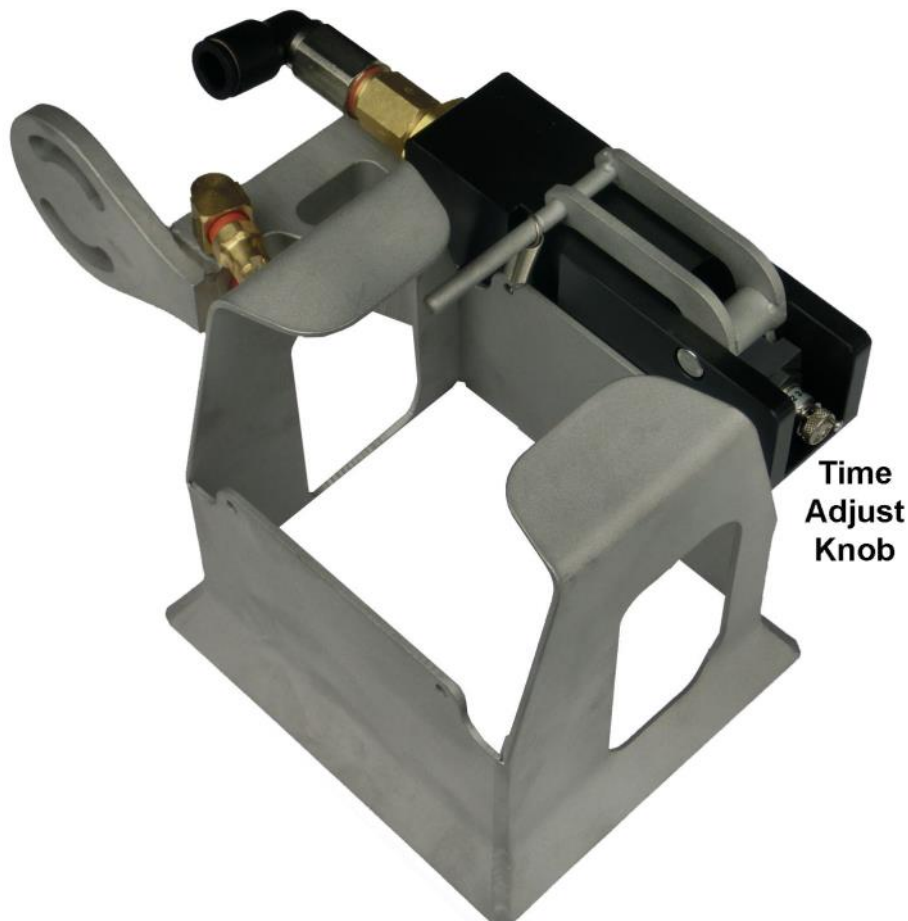

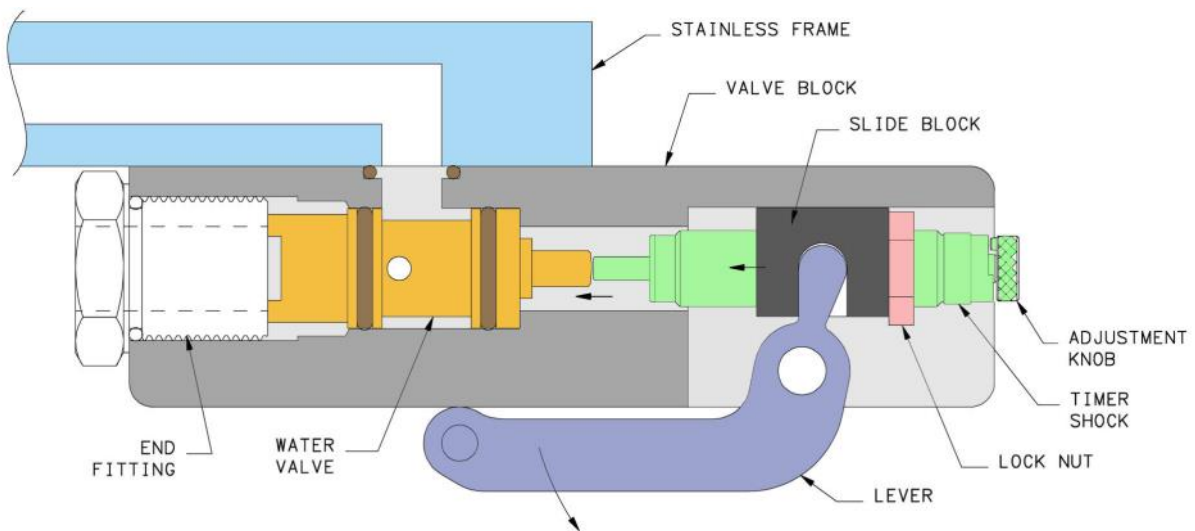
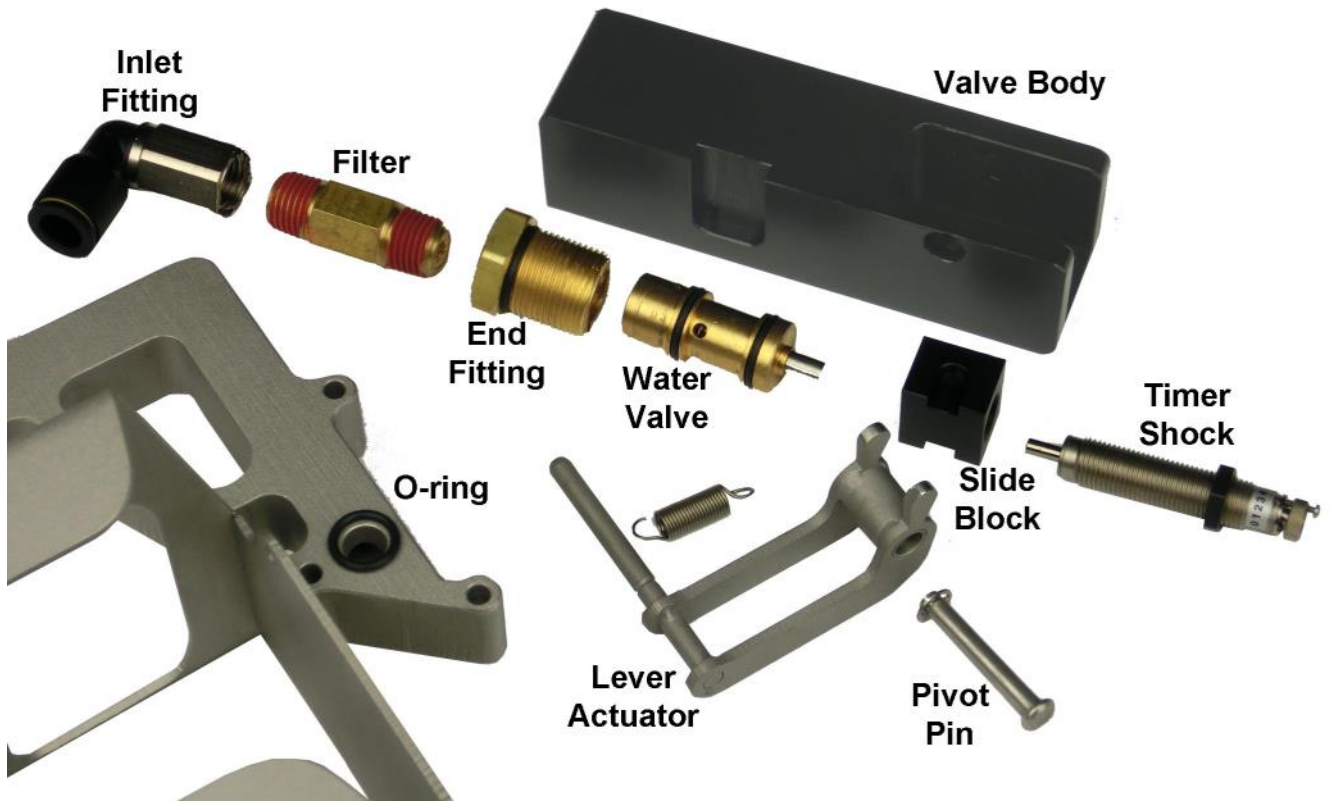

Trouble Shooting

| | |
|--|---|
| <p>No or low water/chemical spray at gun.</p> <p>No chemical mixing with water.</p> <p>Too much or too little chemical mixing with water.</p> <p>Spray at gun does not stop after releasing trigger.</p> | <p>Refer to: No water flowchart, page 31.</p> <p>Refer to: No chemical flow chart, page 32.</p> <ul style="list-style-type: none"> • Clogged chemical pickup hose. • Incorrect chemical metering orifice. • Gun valve pins sticking in valve. • Debris on valve seat O-ring. • Valve seat O-ring damaged. • Refer to gun valve servicing. |
| <p>Gun not cleaning teats as well.</p> <p>Teat belts not moving or with little power.</p> <p>Teat belts not stopping after releasing trigger.</p> | <ul style="list-style-type: none"> • Worn teat belts, flip over or replace. • Teat belts not moving or with little power. • No water/chemical spray. <p>Refer to: Teat belts not moving flowchart, page 33.</p> <ul style="list-style-type: none"> • Gun valve pins sticking in valve. • Debris on valve seat O-ring. • Valve seat O-ring damaged. • Refer to gun valve servicing. |
| <p>Flush station does not spray water.</p> <p>Flush station spray time too short or too long.</p> <p>Flush station spray does not turn off.</p> | <ul style="list-style-type: none"> • Push gun all the way into the holster. • Check for water pressure. • Brass inlet filter clogged. • Delay knob on shock set too loose. • Shock not turned into slide block enough. • Damaged shock or valve. • Adjust time delay knob on shock by loosening lock screw and turning knob a small amount. Check spray time and readjust if needed. • Delay knob on shock set too tight. • Shock turned into slide block too far. • Valve damaged. |

Trouble Shooting

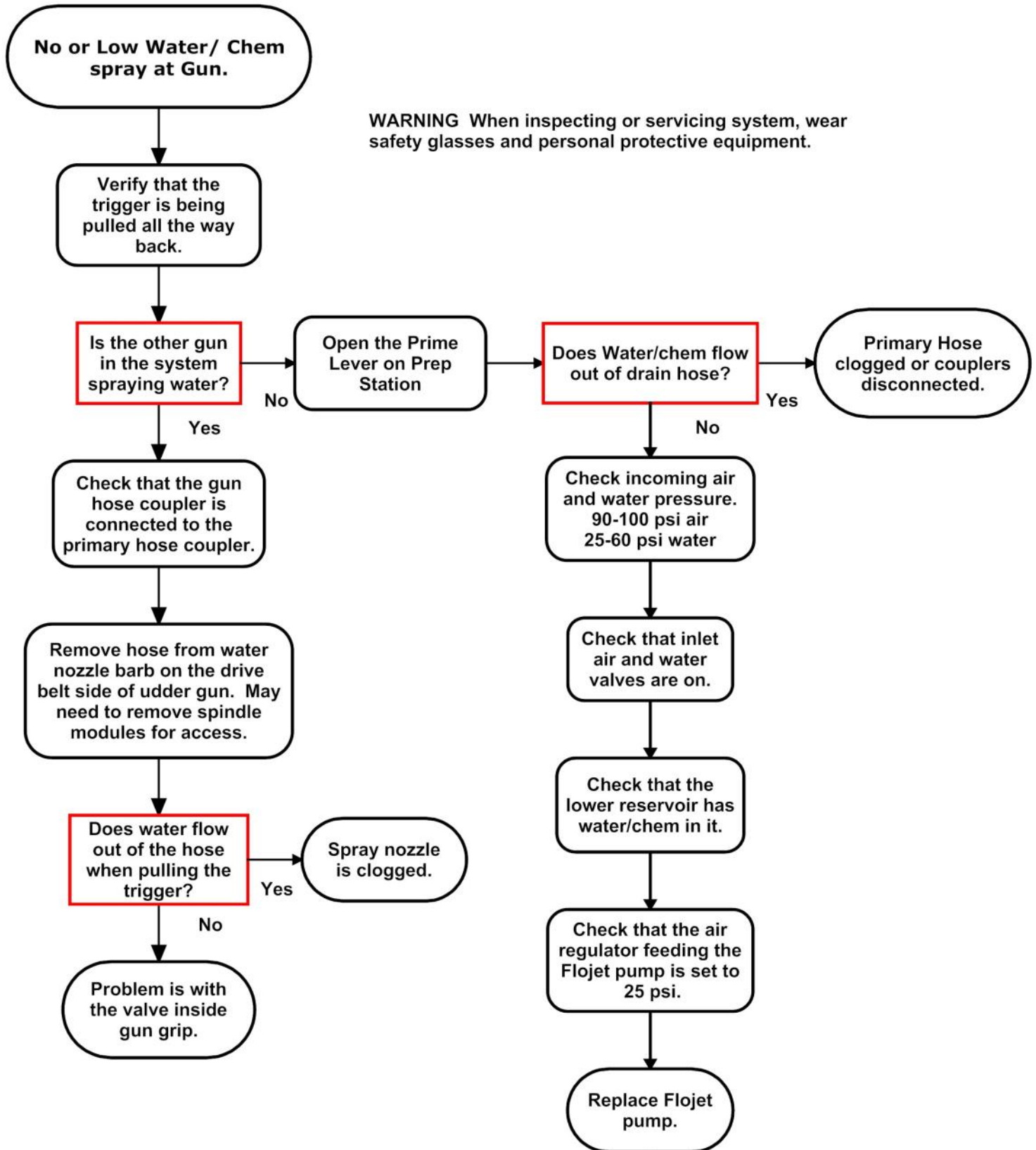

Trouble Shooting

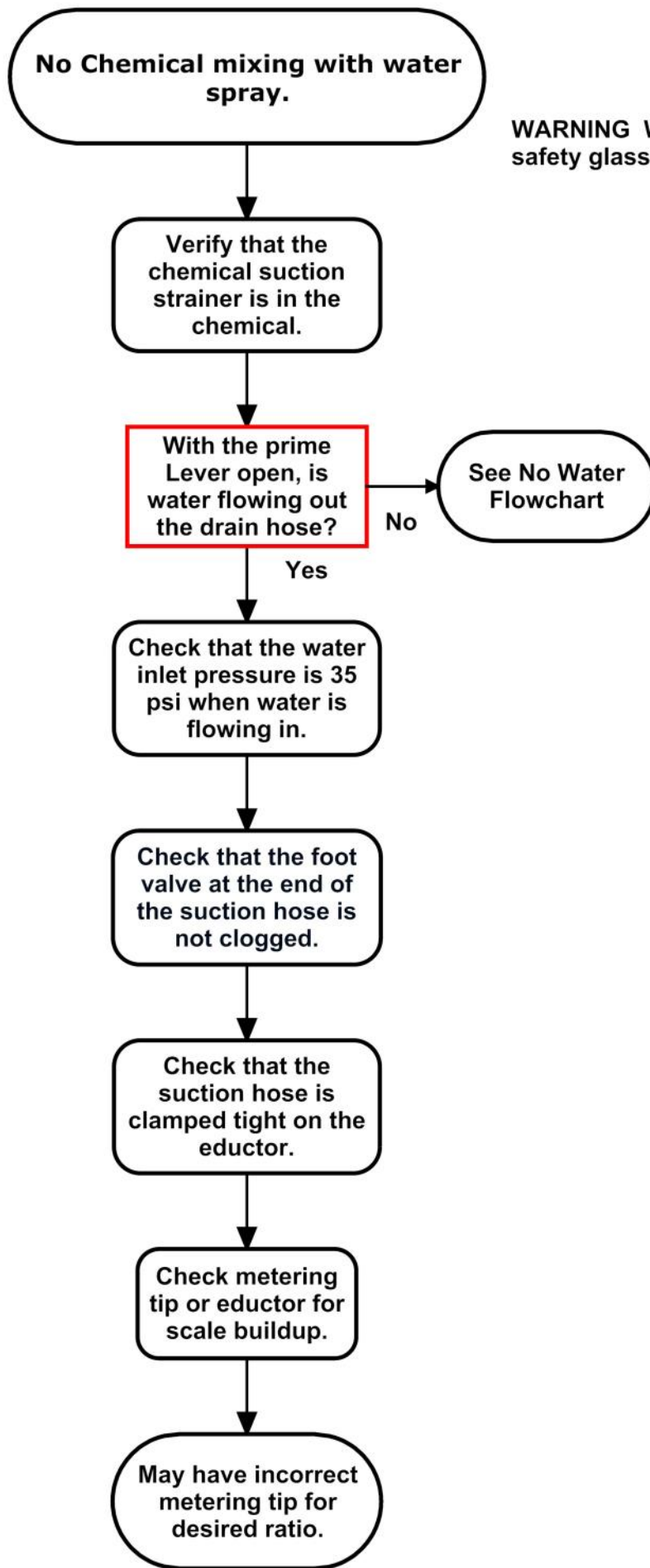

WARNING When inspecting or servicing system, wear safety glasses and personal protective equipment.

Trouble Shooting

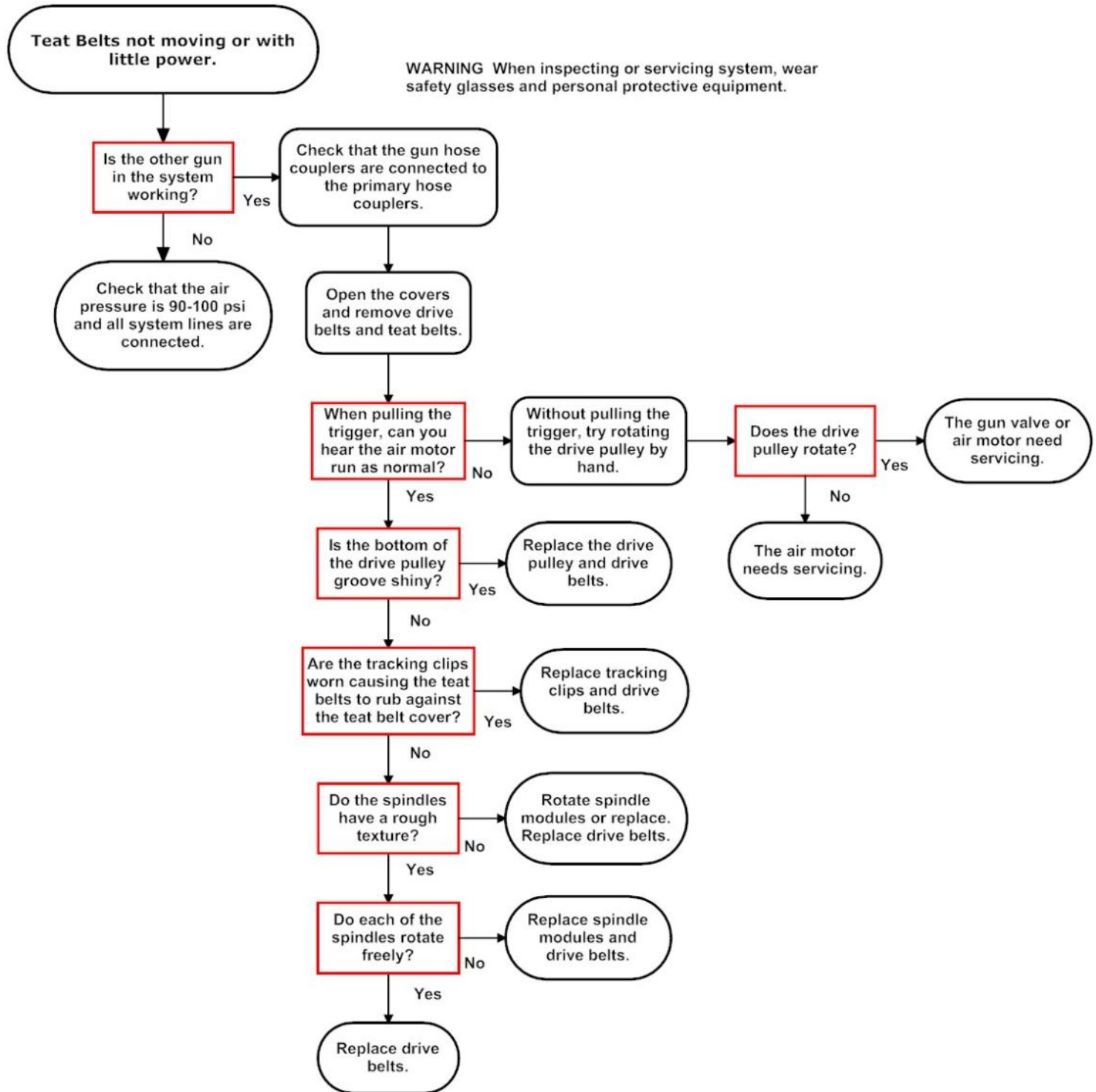

Udder Gun Assembly

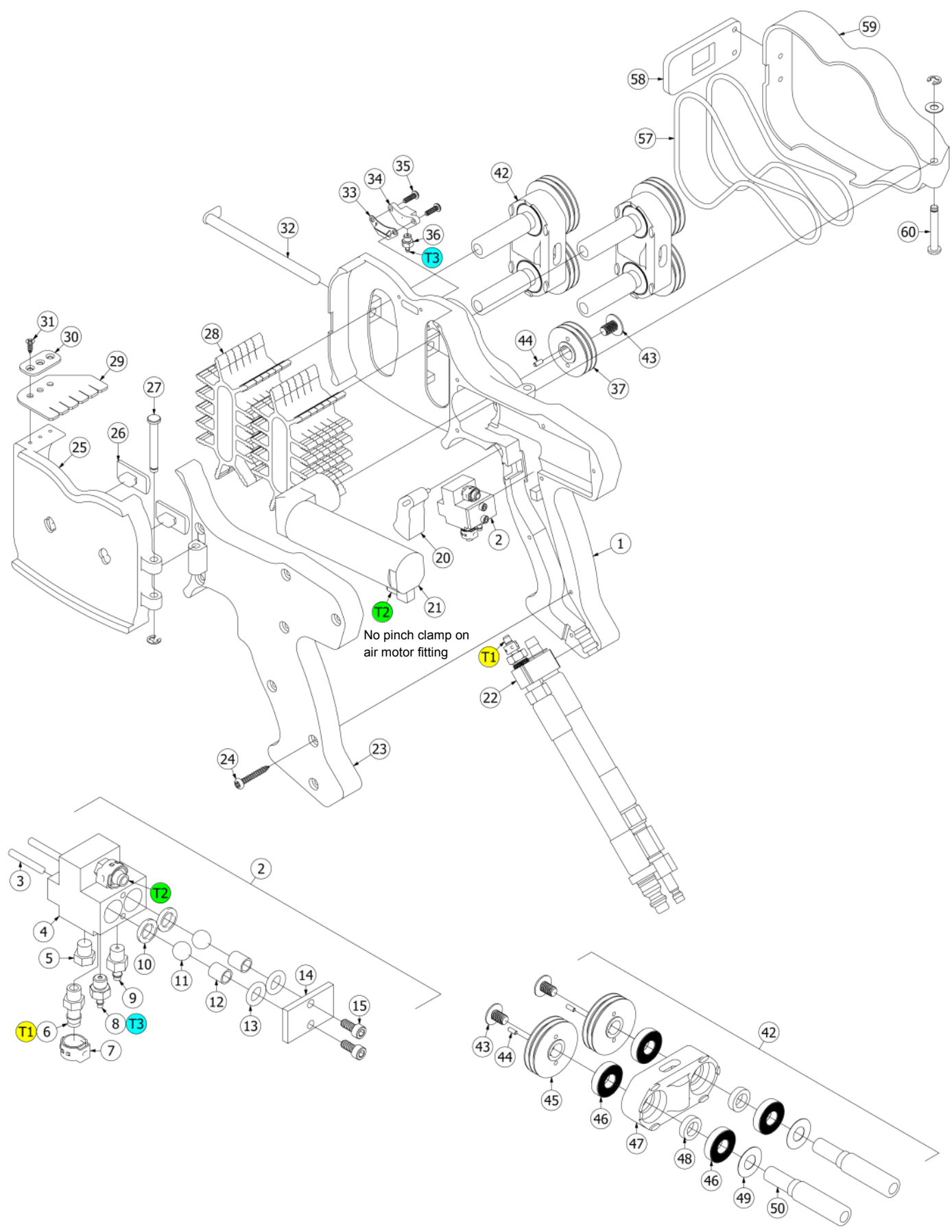

Udder Gun Assembly

| | Description | Part # |
|----|-------------------------------|---------|
| 1 | Main housing | 611843 |
| 2 | Valve assembly | 611829 |
| 3 | Pin, actuator | 611832 |
| 4 | Valve body, w/air fittings | 611830 |
| 5 | Fitting, Plug, #10-32 ss | 182916P |
| 6 | Fitting, .17 Barb, #10-32 ss | 182913P |
| 7 | Pinch clamp, 15/64-9/32 ss | 193903P |
| 8 | Fitting, 1/16 Barb, #10-32 ss | 182915P |
| 9 | Fitting, 3/32 Barb, #10-32 ss | 188631P |
| 10 | O-ring, quad viton 7/32 ID | 182907P |
| 11 | Ball, 1/4 dia ss | 182902P |
| 12 | Spring, .24 dia x .38 lg ss | 182906P |
| 13 | O-ring, .34 OD x 1/16, viton | 182901P |
| 14 | End plate, valve | 611831 |
| 15 | SHCS, 4-40 x 1/4 ss | 182904P |
| 20 | Trigger | 611840 |
| 21 | Air motor | 611813 |
| 22 | Hose assy. (see page 36) | 611886 |
| 23 | Housing, grip half | 611844 |
| 24 | Housing screw kit | 184401P |
| 25 | Teat belt cover | 611846 |
| 26 | Tracking clip | 611760 |
| 27 | Clevis pin, 3/16 x 1.38 ss | 193601P |
| 28 | Teat belt | 611860 |

| | Description | Part # |
|----|--|----------|
| 29 | Splash shield | 611766 |
| 30 | Shield clamp plate | 611767 |
| 31 | Screw, #4 x .38 ss fh | 193602P |
| 32 | Pin, module slide | 611838 |
| 33 | Spray deflector | 611864 |
| 34 | Spray nozzle | 611842 |
| 35 | Screw, SHCS, 4-40 x 3/8 | 194201P |
| 36 | Fitting, 1/16 Barb, #10-32 ss | 182915P |
| 37 | Drive pulley, 1.31 dia | 611723 |
| 42 | Spindle module assy. | 611938 |
| 43 | Screw, 1/4-20 BHCS w/flg | 193803P |
| 44 | Pin, dowel 3/32 x .25 brass | 193801P |
| 45 | Driven pulley, 1.50 dia | 611720 |
| 46 | Bearing, 3/8 ID | 193802P |
| 47 | Spindle module housing | 611835 |
| 48 | Bearing spacer | 611943 |
| 49 | Slinger washer | 611944 |
| 50 | Teat belt spindle, textured | 611837 |
| 50 | Optional Teat belt spindle with heat shrink coating Longer life in sand bedding | 611837HS |
| 57 | Drive belt | 611850 |
| 58 | Cover latch | 611841 |
| 59 | Drive belt cover | 611845 |
| 60 | Clevis pin, 3/16 x 1.13 ss | 193701P |

| Tube connection point | Description | Part # |
|-----------------------|----------------------------------|---------|
| T1 | Tube, .16 ID 1/4 OD polyur clear | 193902P |
| T2 | Tube, .16 ID 1/4 OD polyur clear | 193902P |
| T3 | Tube, 1/16 ID 1/8 OD pvc | 193901P |

Gun Hose Assembly

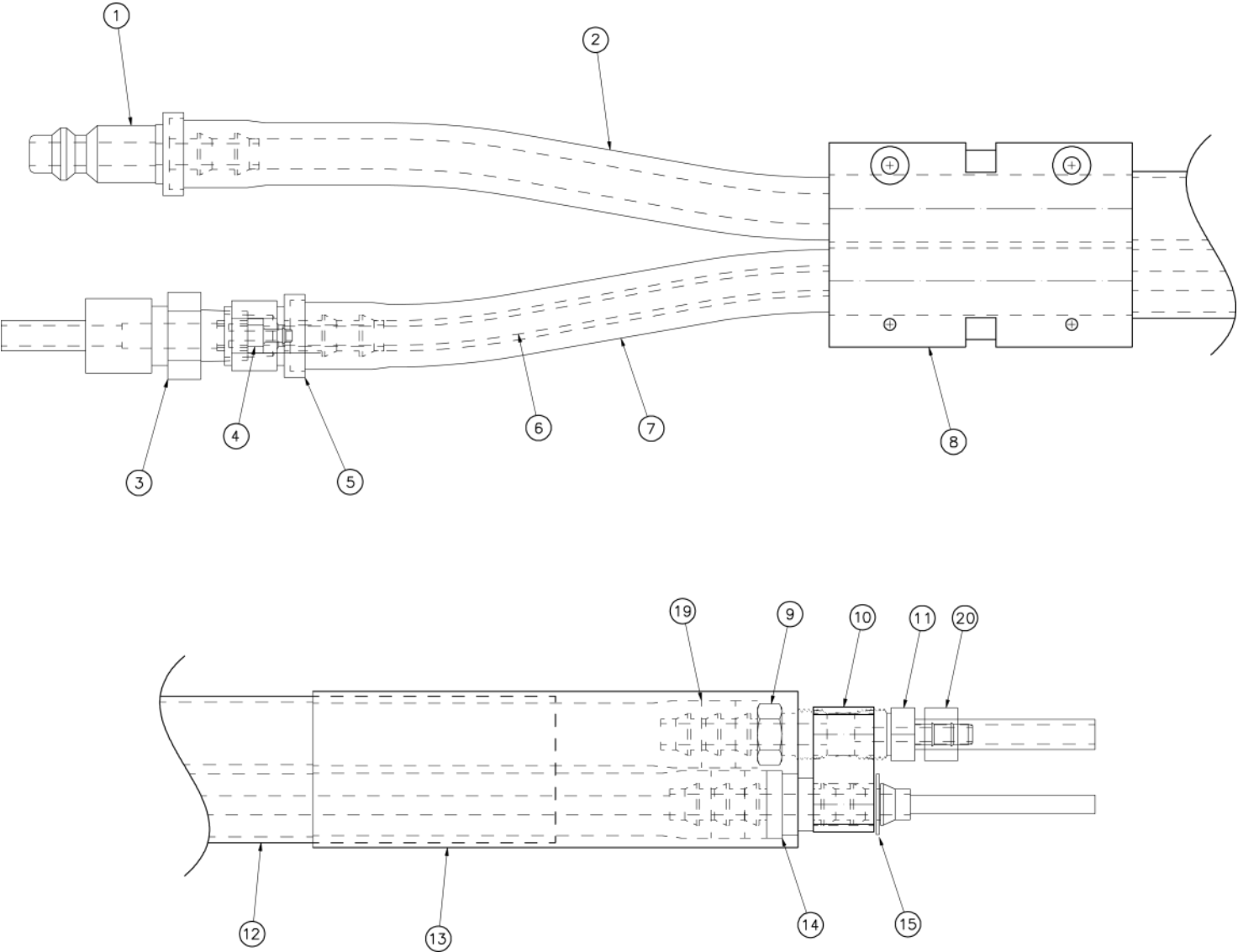

Gun Hose Assembly

| | Description | Part # |
|----|-------------------------------------|---------|
| | Gun hose assembly | 611886 |
| 1 | Fitting, 1/4" hose-M quick cpl | 188627P |
| 2 | Hose, 1/4" ID push on gray | 188622P |
| 3 | Fitting, QC plug, 1/8 M SS | 188629P |
| 4 | Fitting, 3/32 barb, 10-32 SS | 188631P |
| 5 | Fitting, brs barb, 1/4 hs-1/8 npt f | 188630P |
| 6 | Tube, 3/32 ID x 3/16 OD pvc | 188621P |
| 7 | Hose, 1/4" ID push on yellow | 188633P |
| 8 | Clamp block | 612069 |
| 8b | #6 x .75" SS screw | |
| 9 | Fitting, SS barb, 1/4" hose-1/8npt | 188623P |
| 10 | Inlet block | 611839 |
| 11 | Fitting, SS barb, .17 tube-1/8npt | 188628P |
| 12 | Sheath, 1" ID x 33'-4" | 188632P |
| 13 | Heat shrink | 188634P |
| 14 | Fitting, SS barb, 1/4" hose cpl | 188626P |
| 15 | E-clip, 5/16 ss | 188605P |
| 16 | O-ring, 3/16 x 1.25 I.D. | 188614P |
| 17 | Mounting bracket | 612070 |
| 18 | Band clamp, 1/2" x 5" | 188615P |
| 19 | Pinch clamp, 1/2" - 37/64" ss | 188635P |
| 20 | Pinch clamp, 15/64-9/32 ss | 193903P |



Prep Station Assembly



Prep Station Assembly

| | Description | Part # |
|----|-----------------------------------|----------|
| | Prep Station Assy. (complete) | 611856 |
| 1 | Molded shell, with float valve | 192721P |
| 2 | Water float valve rebuild kit | 10091931 |
| 3 | Metering tip, Orange, 20:1 | 690048 |
| 3 | Metering tip, Green, 15:1 | 690037 |
| 3 | Metering tip, med. Brown, 11:1 | 690038 |
| 3 | Metering tip, Blue, 7.5:1 | 690039 |
| | | |
| 9 | Water Assembly | 612187 |
| 10 | Valve, ball bnz, 1/2npt f-m | 192722P |
| 11 | Brkt, mtg filter | 612186 |
| 12 | Screw, #10 x 3/4, ss hex | 192724P |
| 13 | Filter, water, Watts | 192723P |
| 14 | Cartridge, water filter | 192730P |
| 15 | Check valve, 1/4" m-m brass | 192726P |
| 16 | Gauge, 1.5 dia 1/8npt ctr back mt | 192728P |
| 17 | Fitting, pshlk 90, 1/4npt-3/8tb | 192729P |
| 18 | Regulator, 1/4" brass, Watts | 192727P |
| 19 | Bushing, 1/2npt-1/4 brass | 192725P |
| | | |
| 23 | Air Assembly | 612188 |
| 24 | Fitting, pshlk adpt., 1/2tb-3/8tb | 192809P |
| 25 | Fitting, pshlk, 1/4npt-1/2tb | 192808P |
| 26 | Valve, 1/4npt ball, bnz f-m | 192825P |
| 27 | Filter/reg, 1/4npt Numatics | 192801P |
| 28 | Fitting, 1/4 st elbow, brass | 192821P |
| 29 | Pipe, 1/4 x 6" ss | 192822P |

| | Description | Part # |
|----|---------------------------------|---------|
| 30 | Fitting, run tee, 1/4npt brass | 192823P |
| 31 | Pipe nipple, 1/4npt brass | 192824P |
| 32 | Regulator, 1/4" brass, Watts | 192727P |
| 33 | Lubricator, 1/4npt Wilkerson 08 | 192806P |
| 34 | Fitting, 1/4npt-1/2tb elbow | 192807P |
| 35 | Brkt, mtg air outlet | 612185 |
| 36 | Screw, #10 x 3/4, ss hex | 192724P |
| 37 | Gauge, 1.5 dia 1/8npt bottom mt | 192826P |
| 38 | Screw, #8 x 2", ss hex | 192820P |
| 39 | Fitting, pshlk 90, 1/4npt-1/4tb | 192508P |
| | | |
| 42 | Pump Assembly | 612189 |
| 43 | Fitting, 90, 1/4npt-1/4tb kynar | 218908P |
| 44 | Fitting, 3/8 stem 90 pshlk pp | 218905P |
| 45 | Fitting, 1/4" 90 pshlk | 218902P |
| 46 | Tube, 1/4" x 6" hdpe black | 218903P |
| 47 | Pump, Flojet 5700 santoprene | 218901P |
| 48 | Fitting, pump air inlet | 612190 |
| 49 | Fitting, quad, 3/8 pshlk viton | 218904P |
| 50 | Fitting, quad, 3/8 npt viton | 218907P |
| 51 | Screw, #10 x 1", ss hex | 218912P |
| 52 | Tube, 3/8" x 12" hdpe red | 218906P |
| 53 | Block, outlet pvc | 612184 |
| 54 | Valve, 1/4npt ball, nylon m-f | 218909P |
| 55 | Fitting, 1/4npt-1/4tb kynar | 218910P |
| 56 | Tube, 1/4" x 6" hdpe red | 218911P |
| | | |

Primary Hose Assembly

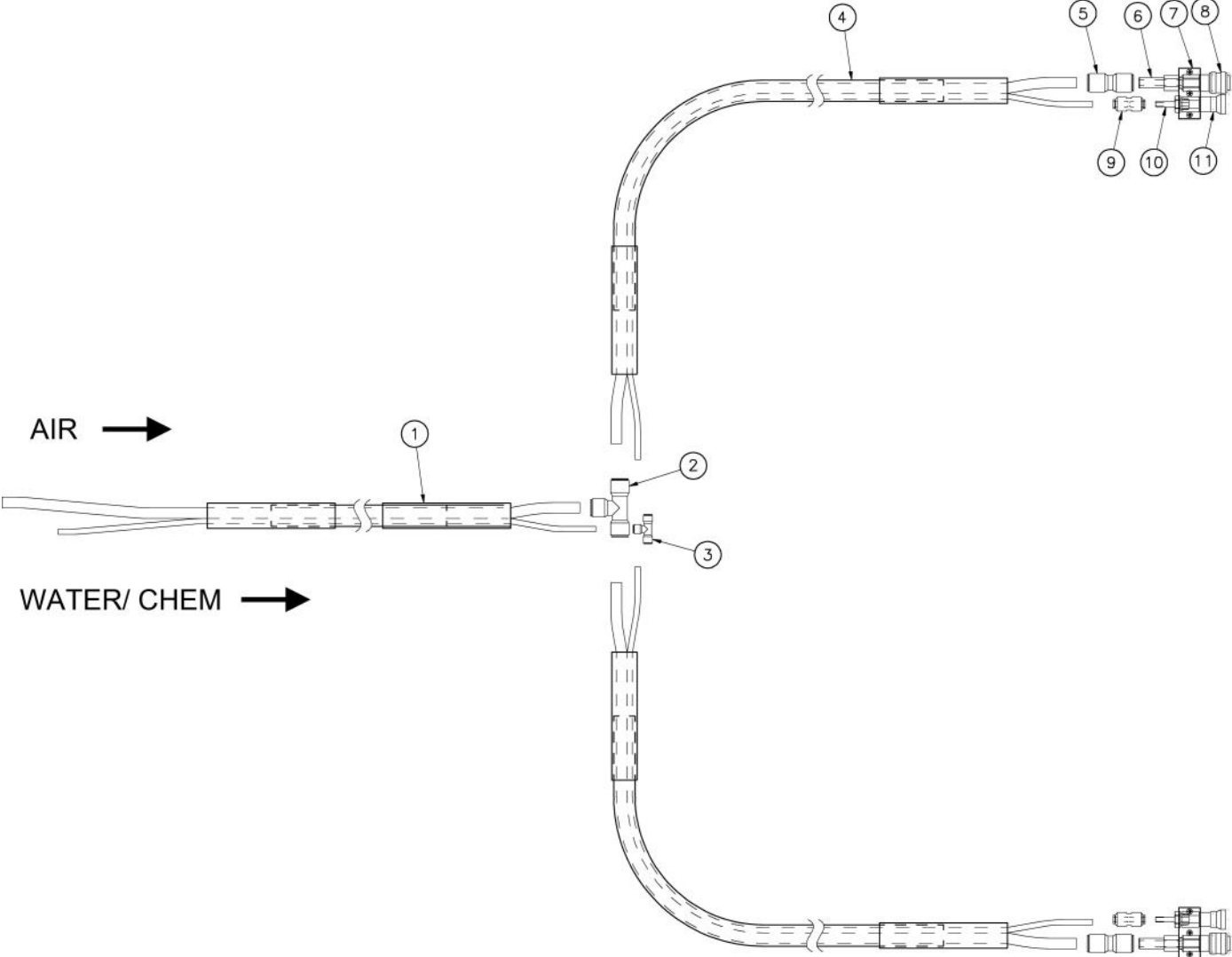

Primary Hose Assembly

| | Description | Part # |
|----|---------------------------------|---------|
| 1 | 50' air and water hose assy. | 611931 |
| 2 | Fitting, 1/2 pslk tee, polypro | 193109P |
| 3 | Fitting, 1/4 pslk tee, kynar | 193114P |
| 4 | 25' air and water hose assy. | 611932 |
| 5 | Fitting, 1/2 pslk cplr, polypro | 193209P |
| 6 | Fitting, 1/2 stem adaptor | 611976 |
| 7 | Clamp, QC fitting | 612191 |
| 8 | Fitting, 1/4 QC npt f | 193210P |
| 9 | Fitting, 1/4 pslk cplr, kynar | 193214P |
| 10 | Fitting, 1/4 stem adaptor | 193215P |
| 11 | Fitting, Swagelok QC, 1/4 npt f | 193216P |

Flush Station Assembly

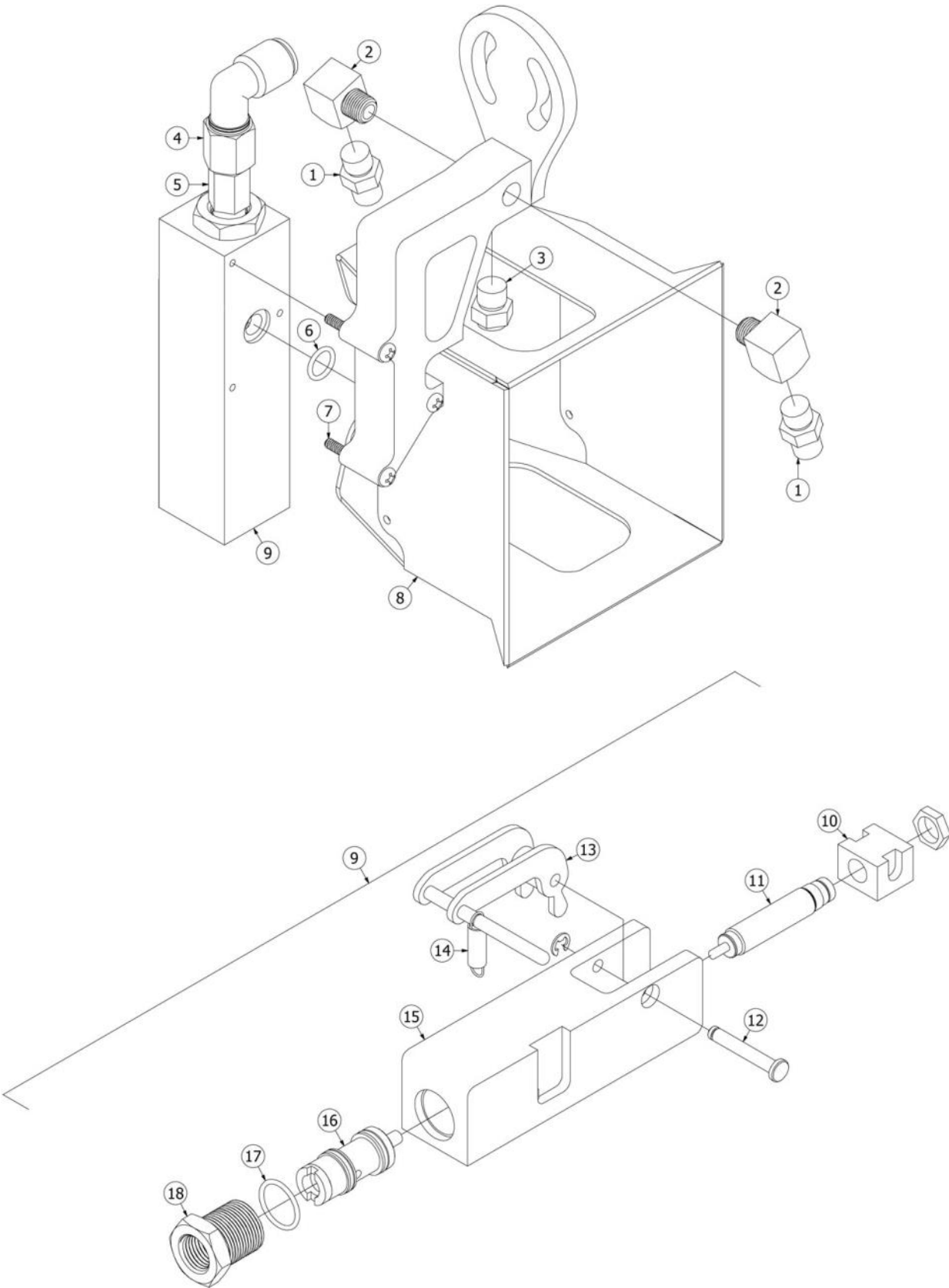

Flush Station Assembly

| | Description | Part # |
|----|---------------------------------|---------|
| 1 | Spray nozzle, 1/8 npt 30° flat | 189901P |
| 2 | Fitting, 1/8 npt brass st elbow | 192513P |
| 3 | Spray nozzle, 1/8 npt sq. | 189902P |
| 4 | Fitting, 1/4 npt f-3/8 90° psk | 188102P |
| 5 | Filter, 1/4 npt m 90 micron | 188101P |
| 6 | O-ring, 1/16 x .50 OD viton | 189803P |
| 7 | Screw, #6-32 x 1.13 pan hd | 189804P |
| 8 | Holster weldment | 611897 |
| 9 | Valve assy., flush station | 611898 |
| 10 | Slide block | 611893 |
| 11 | Hydraulic shock | 189808P |
| 12 | Clevis pin, .19 x 1.13 lg ss | 193701P |
| 13 | Actuator lever | 611896 |
| 14 | Spring, ext, .25 dia x 1 ss | 189809P |
| 15 | Valve body | 611892 |
| 16 | Valve, cartridge | 189813P |
| 17 | O-ring, 1/16 x .75 OD viton | 192703P |
| 18 | Fitting, inlet, 1/4 npt brass | 611895 |

LIMITED 3 MONTH WARRANTY

Westar Mfg. warrants to the original purchaser of Udder Gun equipment to be free from defects in material and workmanship under normal use and service, and when properly maintained by the purchaser. Use or service with corrosive chemicals or equipment subjected to freezing temperatures shall not be deemed normal. Westar's obligation under this warranty is limited to repairing at Westar's factory or furnishing a replacement for any part, or correcting any workmanship, which shall be demonstrated to Westar's satisfaction to have been defective at the time of delivery and with respect to which a written claim specifying the particular defect or defects shall have been delivered to Westar within 3 months from the date of delivery of the equipment to the original purchaser or before the system has cleaned 100,000 cows, whichever period is the shorter.

System parts covered by this warranty are: Prep station module, primary hoses and fittings, trigger and gun valve, gun spray nozzle, air gearmotor (except for internal airmotor cell) and flush stations. All other parts not listed are considered wear parts and are not covered by this warranty. Defective parts shall be returned to Westar F.O.B. Westar's factory, and repaired or replacement parts shall be shipped by Westar F.O.B. Westar's factory. The removal by purchaser of parts returned to Westar for repair or replacement and the installation by the purchaser of replacement or repaired parts shall be at purchaser's expense. No work will be done by Westar at the site of the installation unless in Westar's opinion it is impractical for purchaser to remove the defective part and return it to Westar's factory.

Repairs, replacements or adjustments for which Westar is responsible will be made as promptly as possible within the standard working hours of any day. Overtime, if required by purchaser, will be paid for by purchaser.

EXCEPT AS EXPRESSLY STATED HEREIN, THERE ARE NO WARRANTIES, EXPRESS OR IMPLIED, BY OPERATION OF LAW OR OTHERWISE, OF THE EQUIPMENT OR SERVICES FURNISHED BY WESTAR. WESTAR SPECIFICALLY DISCLAIMS AND EXCLUDES ANY IMPLIED WARRANTY OF MERCHANTABILITY OR FITNESS FOR A PARTICULAR PURPOSE OR ARISING FROM A COURSE OF DEALING OR USAGE OF TRADE. THERE ARE NO WARRANTIES WHICH EXTEND BEYOND THE DESCRIPTION ON THE FACE HEREOF. Westar shall not be liable for, nor does Westar authorize any person to assume for Westar, any other liability in connection with the equipment or services furnished by Westar, including, without limiting the generality of the foregoing, liability for loss of production, product, equipment or profits or liability for direct, incidental, indirect, special or consequential damages or any damages to persons or property. Westar will make no allowances for repairs, alterations or other work done unless specifically agreed to in writing. Purchaser agrees that purchaser's sole remedy for liability of any kind, including negligence with respect to the equipment and services furnished by Westar shall be limited to the remedies provided herein.

**UDDER
GUN**™

US Patent No. 9,072,274
Other Patents Pending

By:

WESTAR
MFG.

814 E First Ave.

P.O. Box 79

Dorchester, WI 54425

Phone (715) 654-5000

Fax (715) 654-5566

Westar Mfg. LLC reserves the right to change or discontinue products without notice. Copyright 2015 © Westar Mfg. LLC, all rights reserved.

DISCLAIMER

Although instructions and recommendations are included for installation and operation of your Udder Gun, Westar Mfg. does not assume responsibility for the installation or use of this equipment nor shall we be held liable for the direct or consequential damages resulting from the improper methods, or procedures.