



www.pinballmachine.com

# Catalog 2000



We carry the world of

# PINBALL

parts · supplies · books · accessories

## Pinballs



High quality carbon-steel pinballs

Special!  
3 balls for \$5

page  
**18**

## Rubber Ring Kits



The best way to make your machine look and play like new!

**\$13.95 - Single playfield games**  
\$17.95 - Double playfield / wide body games

page  
**14**

## Novus plastic polish

The best pinball cleaner available!



page  
**18**

**Novus #1 - \$3.89**  
**Novus #2 - \$4.99**  
**Novus #3 - \$5.49**

## Pinball Price Guide

page  
**4**



Mr. Pinball Price Guide -  
**New for 2001!**

**\$15.00**



# Order Information

## Dear Pinball Machine Owner,

Thanks for joining us in the endless pursuit of pinball perfection!

This catalog is just a sampling of our vast inventory of parts, supplies and information to help you keep your games playing and looking like new. Whether you're operating your machine commercially or preserving and playing a pristine pinball for your personal pleasure, we can help.

Your pinball machine is a work of kinetic art that chronicles popular culture and engineering. Each one is a limited edition collectible that deserves tender loving care.

Read all you can about their maintenance and history and **KEEP THEM CLEAN** and in a climate-controlled environment! There are many pinball maintenance "Pin Tips" throughout these pages to assist.

Don't hesitate to call with your questions or comments. If you're looking for a specific part, be sure to have the part number handy – there are thousands of different pieces for thousands of different machines!

*Sincerely,  
The Staff at Marco*

## MARCO POLICY:

### Terms:

Merchandise and shipping fees must be prepaid by check, cash, money order, C.O.D, PayPal® or major credit card unless an open account has been established by providing 1 bank and 3 open account trade references to us. Please call for a credit application. Make Paypal® money transfers (www.paypal.com) to paypal@pinballmachine.com.

### Minimum Orders:

There is no minimum order for domestic sales, there is a \$100 minimum order for ALL INTERNATIONAL SALES.

### Returned Checks:

Returned checks will be charged an additional \$20.00 handling fee.

### Prices:

All prices are subject to change without notice. All merchandise is subject to prior sale. We cannot be held responsible for typographical errors.

### Damaged Merchandise:

Please open packages immediately upon receipt and notify the carrier to file a claim if goods have been damaged in shipping. Keep all shipping containers for inspection.

### Returns:

All items are unconditionally guaranteed. You may return any items found to be unsatisfactory within 30 days for a full refund. Due to the sensitive nature of electronic components, we cannot offer refunds on new electronic components. Items covered by a manufacturer's warranty should be returned to the manufacturer.

### Shipping:

Orders over 5 pounds are typically shipped UPS ground. Orders under 5 pounds are shipped USPS. All other common carrier methods of shipping are available at your option for additional charge. Contact us for shipping charges on Next Day, 2nd Day, or 3 Day, express, and international service.

### Inquiries

If you have questions about an order, please call us and have your invoice number available.

## Ordering is Easy!

Find our Order Form on Page 38

1

**Web:**

www.pinballmachine.com

2

**Fax Anytime:**

(800)295-8458, (803)957-6974

3

**Call:**

803-957-5500 (10 am - 7pm EST M-F)

We supply parts from the following vendors:



...and many more!

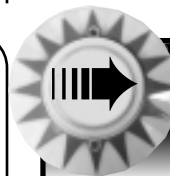

## PinTip: About Pintips

Throughout this catalog, you will find boxes like this filled with useful bits of information or time-saving hints that will help you get the most out of the pinball experience.

All catalog contents ©2000 Marco Specialties, Inc. The names: Williams, Bally, Midway, Atari, Sega, Stern, Capcom, Gottlieb, Data East and any other coin operated device manufacturer as used throughout this catalog are registered names of their respective corporations. Game machine names appearing beneath corporate titles are registered trademarks of those corporations. Reproduction of any catalog contents, in whole or in part is expressly prohibited.

©2000 Marco Specialties, Inc. All rights reserved.

**Marco Specialties Inc.**

803-957-5500

www.pinballmachine.com

fax: 803-957-6974

## PINBALL FRIDGE SOUND MAGNET



With its magnetic back, this miniature pinball machine model attaches to any magnetic surface to remind you of your true obsession. Press the flipper buttons, and real pinball machine noises sputter from the 3-inch tall "Sci-Fi Odyssey" game. There is even a tiny pinball rolling about the playfield. A perfect pin-head present!

**#MINIPIN - Mini magnet pinball machine ..... \$6.95**

## PINBALL ON THE LITTLE SCREEN



Own your own VHS NTSC copy of this professionally produced video that aired on Pay-Per-View. It feature stars such as Guns & Roses guitarist Slash, Pinball historian Ricahrd Bueschel, Aerosmith guitarist Joe Perry, and much more. The entire pinball era is covered, with focus on its cultural impact, in this entertaining documentary chock full of celebrity interviews. A must-see for anyone who has dropped a quarter into a pinball machine.

**#HOP - History of Pinball video ..... \$16.95**

## A BRIEF HISTORY OF PINBALL

1930 - **Little Whirl-Wind** (Howard Peo). The first upright pin game.  
 1931 - **Baffle Ball** (D. Gottlieb & Co.). The first commercially successful pinball machine, selling 50,000 units.  
 1931 - **Bally-Hoo** (Bally Mfg.). Bally's kick-off pinball machine. Sold 75,000 units.  
 1932 - **Advance** (Harry Williams). Williams introduces the "tilt" mechanism.  
 1935 - Stoner Mfg. Co. introduces back-glasses on their "Aristocrat" line of machines.  
 1947 - **Humpty-Dumpty** (D. Gottlieb & Co.). The first pinball with flippers.  
 1948 - Pop Bumpers introduced. Steve Kordek positions flippers at playfield bottom.  
 1951 - Gottlieb introduces the 'slingshot kicker' - still in use.  
 1954 - **Super Jumbo** (D. Gottlieb & Co.) is the first four player game.  
 1956 - **Balls-A-Poppin'** (Bally Mfg.). The first multiball machine.  
 1957 - Wooden legs replaced by steel.  
 1960 - **Flipper** (D. Gottlieb & Co.). The first add-a-ball pinball machine.  
 1960 - **Magic Clock** (WMS Electronics). The first pinball machine with a moving target.  
 1966 - **Bazaar** (Bally Mfg.). The first pinball machine with zipper flippers.  
 1968 - Williams increases flipper from 2" to the current 3" size.  
 1971 - **Challenger** (D. Gottlieb & Co.). The first 2-player head-to-head pinball machine.  
 1971 - **2001** (D. Gottlieb & Co.) is first with in-line drop target banks.  
 1972 - Pinball legalized in Los Angeles after a 33 year absence.

1975 - **Super Flipper** (Chicago Coin). The first video pinball game.  
 1975 - **Dyn'O Mite** (Allied Leisure). First hybrid solid state/electromechanical pinball machine.  
 1975 - **Spirit of '76** (Micro Games). The first totally electronic solid state pinball machine.  
 1976 - Pinball legalized in New York City and Chicago after a 35 year absence.  
 1977 - **Atarians** (Atari). The first wide-body pinball machine.  
 1979 - **Gorgar** (Williams Electronics). The first talking pinball.  
 1980 - **Firepower** (Williams Electronics). The first electronic pinball to feature multi-ball play.  
 1982 - **Caveman** (D. Gottlieb & Co.). The first combination pinball/video machine.  
 1984 - Gil Pollock and investors buy Gottlieb, change name to Premier.  
 1987 - **Laser War** (Data East). Data East's first machine, and the first one to feature stereo sound.  
 1987 - **Banzai Run** (WMS Electronics) First pinball to feature vertical + horizontal playfields.  
 1988 - Williams Electronics takes over Bally pinball manufacturing.  
 1989 - Data East introduces solid state flipper on **Robo Cop**.  
 1994 - Data East Pinball aquired by Sega, renaming the company to Sega Pinball, Inc.  
 1996 - Gottlieb/Premier closes its doors.  
 1999 - Gary Stern aquires Sega Pinball, renaming the company to Stern Pinball.  
 1999 - Williams shuts down its pinball division.

## Quick Index

### Books 4-13

Collector's .....	4-5
Manuals .....	7
Factory Literature .....	8-13
Parts Catalogs .....	8-13
Tech Books .....	6-7

### Parts 19-32

Armatures/Plungers .....	24
Ball Shooter Parts .....	26
Bumper Caps .....	23
Bumper Parts .....	23
Buttons .....	26
Cabinet Hardware .....	26
Coils/Coil Sleeves .....	24
Connectors .....	28
Cords .....	28
Drop Targets .....	27
Electronic Components .....	29
Flipper Bats/Shafes .....	23
Flipper Parts .....	21-22
Flipper Rebuild Kits .....	22
Fuses .....	30
Lamp Socketes .....	20
Lane Guides .....	19
Legs .....	26
Locks .....	26
Metal Posts .....	20
Mylar .....	32
Optos .....	30
Plastic Posts .....	19
Screws/Nuts .....	20
Springs .....	17
Switches .....	25
Targets .....	25
Trim .....	32

### Supplies ..... 14-18

Bulbs/Lamps .....	16
Cleaners .....	18
Displays .....	16
Paints .....	18
Polishes .....	18
Pinballs .....	17
Rubber Parts .....	14-15

### Order Forms 35,37

### Parts Kits ..... 34

### Upgrades ..... 31

### Tools ..... 33

## PRICE GUIDES

### MR. PINBALL MACHINE INDEX

by Daina Pettit



Fresh from pinball machine archivist Daina Pettit comes the 2001 edition of his 124 page, wire bound pinball machine, bingo, and baseball index. The alphabetical listing also includes key coded entries for game features and books with pictorial or text references. Appendices contain serial number statistic comments, bibliography, and a glossary. Covers over 2000 flipper style machine titles made between 1947 and 2000 and a large number of the "holy grail" of data for collectors -- production numbers!

**#MPPI - Mr. Pinball Machine Index**  
**\$15.00**

### PENNY ARCADE PRICE GUIDE

By Larry Bieza

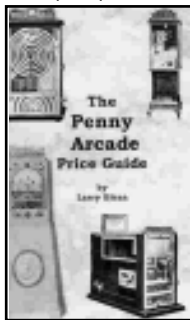

The Penny Arcade Price Guide by Larry Bieza contains valuable information for collectors including date of introduction, price, and notes on a wide variety of penny arcade machines. The categories are broken down into areas for baseball games, bowling and shuffle games, diggers/cranes, driving games, fortune tellers, gun games, and miscellaneous machines. 84 pages, B&W photos, softcover.

**#APG97 - Penny Arcade Price Guide**  
**\$16.00**

## ARCADE COLLECTING

### Arcade Treasures by Bill Kurtz:

Coin-op collectors' favorite historian has done it again and brought the arcade memorabilia movement to life with this great book. This hard-cover, 167 page book is filled with 447 color photos and commentary on the greatest pinball, baseball, arcade, fortune teller, novelty, and video games ever. Has tips on locating, trading, repairing, and maintaining your games.



### Arcade 1 by Bueschel & Gronowski:

It isn't pure pinball, but a fascinating retrospective of machines on the pinball periphery: baseball machines, shuffle alleys, gun games, fortune tellers, and dozens of types of intriguing arcade equipment from 1885 to 1983. The 306 page softcover book contains B&W photos, biographies, and anecdotes describing the creation and operation of the coin-op wonders of their day.

**#ATK - Arcade Treasures** ..... **\$39.95**  
**#AIB - Arcade 1** ..... **39.95**

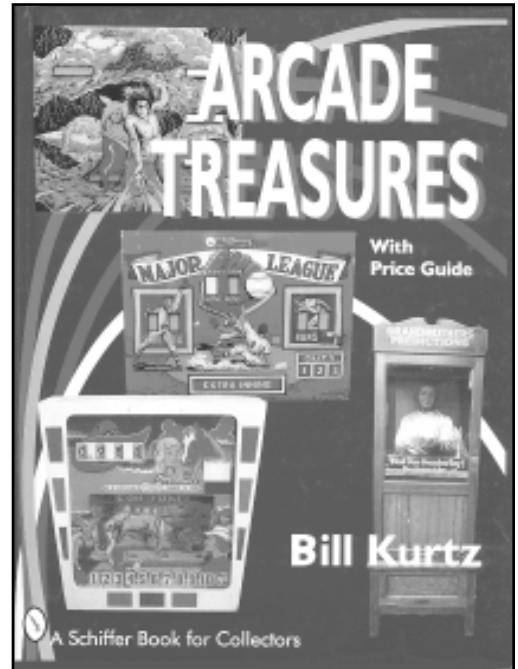

## BINGO MACHINES



### BALLY BINGO PINBALL MACHINES

by Jeffrey Lawton

Finally, the segment of pinball often omitted in other collectors books is thoroughly covered in this handsome 162 page hardback color book. Bingo pinball historian Jeffrey Lawton goes into great depth covering the gameplay and history of the machines, beginning with the simpler early machines in 1951 to the "20 holer" games of the '60s. Also included are sections containing technical tips, trouble-shooting procedures, and common problems. This is one book that any serious collector, pinball or bingo, should own.

**#BBPM - Bally Bingo Pinball** ..... **\$39.95**

## PINBALL HISTORY

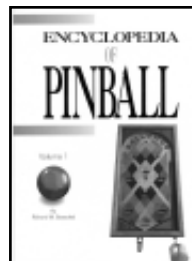

Volume 1

### Encyclopedia of Pinball, Vol. 1 by Richard Bueschel:

This comprehensive encyclopedia volume covers the origins of pinball from 1930 to 1933 when pinball entered popular culture. It covers the machines of the era and patent wars.

### Encyclopedia of Pinball, Vol. 2 by Richard Bueschel:

The second volume of this historic series includes topics such as: Ending the patent wars, electricity comes to pinball, and more. Covers the years from 1934 to 1936.

**#EOP - Encyc. of Pinball Vol. 1** ..... **\$49.95**  
**#EOP2 - Encyc. of Pinball Vol. 2** ..... **49.95**

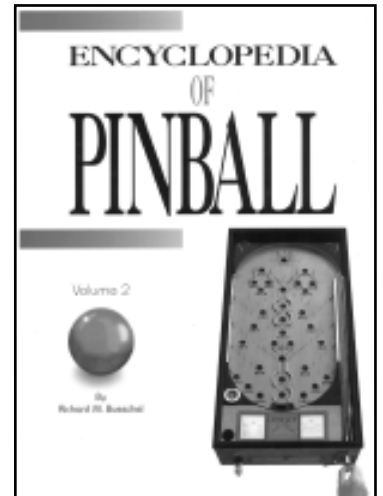

Volume 2

**PinTip:**  
**Careful with the cleaning!**

Don't use petroleum-distillate based cleaners on your playfields around clear plastic shields—they can dissolve the adhesive backing and lift the plastic up along with playfield paint (NOVUS polish has no distillates)!  
See page 18 for cleaning supplies.



# Collector Books

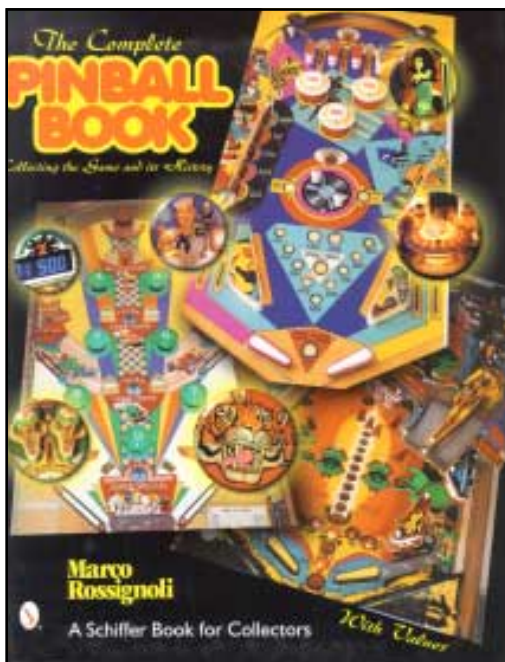

## Got Pinball? THE COMPLETE PINBALL BOOK

by Marco Rossignoli

This hardcover tome is the heavyweight of pinball books, weighing in at over 4 pounds. The 320 page book vividly displays the evolution of the features that pinball players have come to love in today's modern machines, while highlighting the fantastic artwork that is a crucial element of the machines. The detailed history covers machines from the 1930s to the 1990s. It includes a listing of over 3000 games built to date, including statistics, pricing information, and over 900 color photographs. This book is definitely one of the most comprehensive collectors' books out there, and a must-have for any pinball lover's library.

#CPB - Complete Pinball Book .... \$59.95

## COLLECTOR'S GUIDE TO VINTAGE COIN MACHINES

by Richard Bueschel

This release from coin-op machine scholar Dick Bueschel is a 200 page, hardcover edition with collecting tips, resources, and a price guide. Has hundreds of captioned color photos of slot machines, jukeboxes, pinball, arcade, vending, and scale devices from the 1900's through the video game era. This is an important reference work for your library.

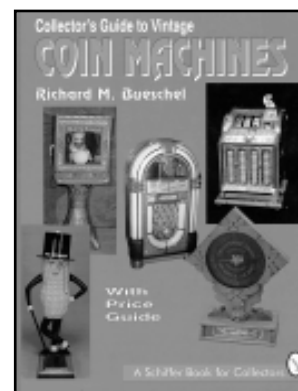

#CGB - Collector's Guide, Vintage Coin Machines \$38.95

## PINBALL MACHINES

by Eiden & Lukas

This 3rd edition coffee table style book consisting of 168 pages of color & B&W photos of about 200 pinball machines with emphasis on backglass art. This guide for collectors provides an alphabetical overview of the variety, artistry, & ingenuity that has made pinball a chronicle of pop culture. Highly recommended.

#PME - Pinball Machines ..... \$35.00



## SLOT MACHINES AND COIN-OP GAMES

by Bill Kurtz

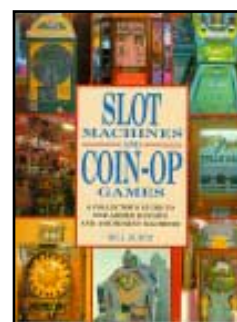

Don't let the cultural misnomer in the title confuse you (a 'slot machine' in Europe isn't only a one-armed bandit — it's any amusement device with a coin slot) This 128 page color coffee-table type book focuses on reel-type slots and various arcade games (with a great pinball section, too). Kurtz is a master coin-op collector & writer who contributes frequently to GAMEROOM magazine and industry trade journals. This book is an important historical reference.

#SMK - Slot Machines & Coin-op Games ..... \$35.00

## PINBALL 1

by Richard Bueschel

A 248 page soft cover book containing info, anecdotes, and B&W photos of the top 100 pinballs from 1931 to 1978. Also contains a 111 page history and reference guide.

#PIB - Pinball 1 ..... \$34.95



## CHARLES BELL: THE COMPLETE WORKS

by Geldzahler

This is not a collector's reference book inasmuch as a photo-realistically rendered journey that reminds collectors why they collect. The 146 page hardcover contains spectacular color lithographs of Bell's incredible oil paintings of gumball and pinball machines and other vintage toys. (Bally PARAGON owners will delight to the 'balls-eye' views of this machine.)

#CBC - Charles Bell, the Complete Works \$45.00

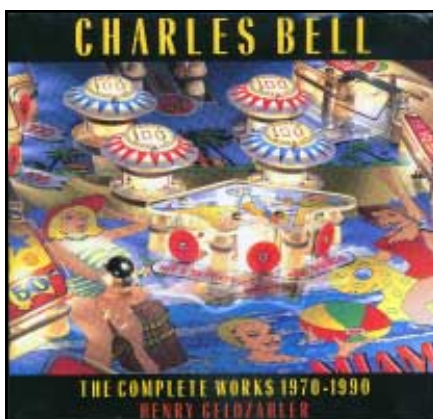

## PINBALL AND WORLD WAR II

by Terry Cumming

*Pinball and World War II* explores the turbulent times of the WW2 period with respect to pinball in America. Never before or after has there been such a unique and interesting time for the game. All aspects of the game are explored in detail in this 118 page comb-bound volume. Numerous ads and photos are also featured. To top it off, a definitive conversion game list is provided for reference.



#PWW2 - Pinball & WWII ..... \$24.95



# Tech Books

NOVICE

## PINBALL TROUBLESHOOTING GUIDE

For electro-mechanical pinball devotees, Russ Jensen details basic electrical theory and explains how to read schematic diagrams in this 50 page softcover guide. Sections covering basic circuits, switches, and troubleshooting techniques are included along with diagrams and photos of typical machines.

#PTG - Pinball Troubleshooting Guide \$19.95

NOVICE

## WPC TROUBLESHOOTING MANUAL

by Snicer

Here is an excellent and, hard to believe but true, EASY TO UNDERSTAND novice's repair guide for late model WILLIAMS pinball (System 11 and WPC) machines. This is a large format book with big pictures and diagrams intended to help isolate problems to the assembly level.

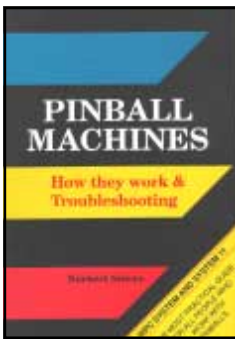

#WPCNS - WPC Troubleshooting \$29.95

ADV.

## REFERENCE HANDBOOK FOR GAMES TECHNICIANS

by Stanley

These 178 page soft cover books are written by a man with many years experience in the coin-op business. This manual is a compilation of technical facts on jukeboxes, pinballs, and early videogames. It contains cross references from manufacturer to generic part #'s for tubes, transistors, IC's, coils, lamps, monitors, phonographs, and many other components. If you've ever had to fix any early solid state coin-op machines, this book is for you.



#RHS - Ref. Handbook by Stanley .... \$21.95

NOVICE

## PINBALL MACHINE CARE AND MAINTENANCE

by Bernard Bear Kamaroff

Everyone shopping for a machine and new owners will find a wealth of valuable information and step-by-step help in this thorough manual. It covers both electromechanical and electronic machines from ground-up. The wealth of topics include:

- Choosing and purchasing a machine
- Easy adjustments
- Descriptions and illustrations of components
- Cleaning and maintenance
- Troubleshooting and do-it-yourself repair
- Keeping the flippers 'hot'
- And much more!

#PMCM - Pinball Machine Care and Maintenance \$24.95

# Pinball Machine

Care and Maintenance



by Bernard Bear Kamaroff  
Bell Springs Pinball Alley

NOVICE

## GOTTLIEB INSTRUCTION & SERVICE MANUAL

Even though this 70 page booklet was written by the GOTTLIEB people in the 60's, it remains an excellent source of generic information for any electro mechanical (EM) pinballs made after 1960. Contains sections starting with an excellent glossary of terms used by all machine makers, descriptions and adjustments of components and assemblies, circuit analysis, troubleshooting, game setup, and maintenance. This is a novice technician's guide to EM's that even pros can glean useful tips from.



#GISM - GTB Instruction and Service Manual ..... \$9.95

NOVICE

## PINBALL MACHINE MAINTENANCE

by Henk De Jager

This book is for you who have electromechanical basket-cases. New, recently translated from the Dutch author, this 196 page soft cover volume provides in-depth help for ailing EM's built between 1960 and 1977. This is an exhaustive exploration designed for the both the novice with little knowledge of electricity and the seasoned tinkerer. Includes many diagrams, drawings, tips and hints for amateur technicians on BALLY, GOTTLIEB, and WILLIAMS equipment. Covers everything from light bulbs, to relays, to coin mechanisms. Highly recommended.



#PMM - Pinball Machine Maintenance ..... \$37.95

NOVICE

## NOVICE GUIDES

**WMS - Introduction to Coin Operated Amusement Games:** A 66 page, 8 1/2" x 11" guide to Williams electromechanical terminology that includes pictures and description of commonly used assemblies and components of pinball and baseball games. Has a glossary of coin machine jargon, troubleshooting section, wire color code chart, and chart of schematic symbols.

#WMSICA Intro to Coin-Op Games \$10.95

**Introduction To BALLY Flipper Games:** This 48 page comb bound, 8 1/2" x 11" novice level instruction book contains sections on terms & definitions, wire color codes, lubrication & adjustment instructions, relay, step-up, credit unit descriptions and other assembly information. Also contains instructions on servicing and troubleshooting.

#BLYIFG - Intro. to BLY Flipper Games \$9.95

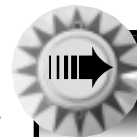

### PinTip: Know your Gottlieb

Many dead Gottlieb early solid-state games are mis-diagnosed as having circuit board problems when the problem is simply a dirty or broken coin door slam tilt switch. The slam switch and the ball roll tilt switch are the only **NORMALLY CLOSED** switches on these games. To make matters even more complex, the last 5 System 80B games changed these switches back to **NORMALLY OPEN**!





## STAR★TECH PINBALL BULLETINS

### ELECTRONIC PINBALL REPAIR AND MAINTENANCE VOL. 1:

Secrets from the best pinball techs in the industry are revealed by the coin-op editors of STAR★TECH Journal, the professional technician's trade magazine. This 118 page compilation of 203 factory revisions and technicians' fix articles covers solid state machines from all major manufacturers. The 15 general tips articles that cover subjects such as weak flipper cures, fixing switch matrices, and more are especially useful. Covers the following machines:

8-Ball champ	El Dorado	Jokerz	Space Shuttle
Aftor	Elvira	Laser War	Split Second
Agents 777	F-14 Tomcat	Millionaire	Simpsons
Atilla the Hun	Fire!	Mon. Nite Football	Spring Break
Back to the Future	Fireball Classic	Motorhome	Star Trek
Batman	Funhouse	Party Animal	Taxi
Black Knight 2000	Gilligan's Island	D.E. Playboy	TMNT
Black Water 100	Gold Wings	Rabbit Punch	Time Machine
Centaur	Hardbody	Robocop	Truck Stop
Comet	Heavy Metal	Rollergames	Terminator 2
Diner	High Speed	Secret Service	Whirlwind
Dr. Dude	Hot Shots	Silver Slugger	Xenophobe
Eight Ball Deluxe	Ice Fever		

#STBOSS - Star Tech Pinball Repair & Maint. Vol. 1  
\$39.95

### ELECTRONIC PINBALL REPAIR AND MAINTENANCE VOL. 2:

This volume contains 140 pages of information that picks up where Volume 1 leaves off. This edition focuses on pinball machines built from the mid-1980's through the mid 1990's and includes bulletins and tips on the specific games listed to the right, as well as: Williams/Bally general illumination; low solenoid voltage, and dozens of other general and specific electronic pinball machine technical topics. Get this manual and stay informed about your machine!

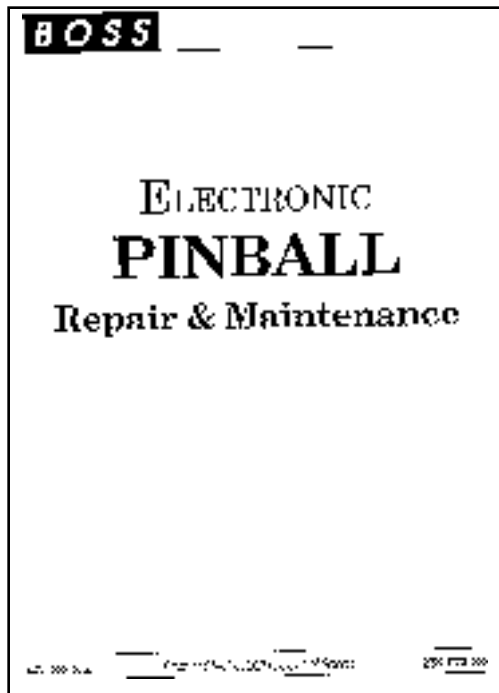

Apollo 13	Fish Tales	Lethal Weapon 3	Star Wars
Addams Family	Flintstones	Party Zone	Street Fighter 2
Batman Forever	Frankenstein	Pennant Fever	GTB Strikes & Spares
Black Knight 2000	Getaway	Phantom	Terminator 2
Comet	Guns N' Roses	Popeye	Twilight Zone
Cue Ball Wizard	Hook	Rollergames	Time Machine
Cyclone	Hot Shot	The Shadow	Whitewater
Demolition Man	Indiana Jones	Simpsons	World Cup
Dracula	Judge Dredd	Spy Hunter	Soccer
Dr. Who	Jurassic Park	Star Trek T.N.G.	

#STBOSS2 - Star Tech Pinball Repair & Maint Vol 2..... \$39.95

### BALLY HOME PINBALL GAMES - TEST PROCEDURES MANUAL



The BALLY Standardized Test Procedures Manual for Series I & II Home Pinball Games covers troubleshooting and maintenance for all the home style electronic pinball games that BALLY produced. The Series I games are FIREBALL & EVEL KNEVEL; the Series II games are CAPTAIN FANTASTIC, GALAXY RANGER, and another FIREBALL. Diagnostics and troubleshooting are described in sections that include Display, Switch Matrix, Solenoid, Sound, CPU, Mechanical Adjustments, and all wiring diagrams and schematics. Also included are data sheets for all solid state devices used in the game to help you substitute parts.

#BLYH - Home Pin Manual \$24.95



#### PinTip: Cool Bulbs

Switch to #47 lamps to let your machine run cooler. They burn slightly dimmer than #44's, but draw less current and last longer. (See page 16)



#### PinTip: Pin-Comfort

Store your pinball machine in a climate-controlled environment whenever possible. Large temperature and humidity changes hasten the deterioration of backglass and playfield artwork.



## REPLACEMENT MANUALS FOR YOUR MACHINE!

WE CARRY ALL OF THEM!

Whether your copy is mangled or missing, we can furnish new originals for all late model games. We also have thousands of older manuals available in our library. **Be sure to specify game name, manufacturer.**

#MANUALS - Solid state manual (>1977) \$25.00

#MANUALE - E.M. Manual (games < 1977) 20.00



# Factory Literature

## BALLY ELECTRONIC PINBALL THEORY OF OPERATION

This 20 page manual, BALLY #FO-601-02, is intended for the experienced technician who wants an in-depth explanation of the BALLY 6800 based MPU system. It is the same material presented at BALLY service schools and complements the FO-560-3. This booklet explains exactly what goes on during all those MPU green LED flashes and how the MPU communicates with the rest of the game hardware. Get this booklet to help troubleshoot those "dog" problems!

#BLYFO60102 - BLY Theory of Operation  
\$9.95

## BALLY ELECTRONIC PINBALL REPAIR PROCEDURES

This is the 92 page factory repair manual #FO-560-3 for the very popular BALLY (and STERN) electronic coin-op games made from 1977 through 1982. It

has two sections of troubleshooting instructions for isolating problems to both the module and component level. Includes pictorial guide and parts lists (but not schematic diagrams) of all major electronic assemblies. Also includes Theory of Operation & Troubleshooting section for BALLY sound modules. One of these books was shipped in every new BALLY machine made in this era, but most seem to have disappeared just when you need them most. This is the single most useful document for taking care of your early BALLY electronic pinball machine.

#BLYFO560-3 - Electronic Repair Procedures ..... \$18.95

#BLYFO560-3 - Electronic Repair Procedures ..... \$18.95



### PinTip: Bad Batteries

Mount your new MPU battery somewhere off the board using a remote battery holder (page 30). If and when it leaks, it won't destroy a valuable circuit board! Change your battery every 2-3 years!



## PARTS CATALOGS

### 1969 PARTS CATALOG

This 174 page catalog covers all BALLY pinball machines from manufactured from Feb. 1963 through Jan. 1969. Includes assembly diagrams, game by game part #'s, and a numerical part # listing. Covers these machines:

- |               |               |
|---------------|---------------|
| Aces High     | Dogies        |
| Band Wagon    | 50/50         |
| Bazaar        | Gold Rush     |
| Big Day       | Grand Tour    |
| Blue Ribbon   | Happy Tour    |
| Bullfight     | Harvest       |
| Bus Stop      | Hay-ride      |
| Bongo         | Hootenanny    |
| Capersville   | Loop The Loop |
| Campus Queen  | Mad World     |
| Cosmos        | Magic Circle  |
| Cross Country | Mini-zag      |
| Cue-tease     | Monte Carlo   |
| Discotek      | Moon Shot     |
| Dixieland     | Rocket Iii    |



- |             |              |
|-------------|--------------|
| Rock Makers | Surfers      |
| Safari      | The Wiggler  |
| Sheba       | 3-in-line    |
| Six Sticks  | Trio         |
| Sky Divers  | 2-in-1       |
| Star-jet    | Wild Wheels. |

#BLY1969 - BLY 1969 Parts Catalog ..... \$21.95

### 1976 PARTS CATALOG

Factory catalog contains details of all assemblies for electro-mechanical BALLY pinballs from 1969 through 1976. This spiral bound, 218 page manual includes exploded assembly diagrams, playfield charts, and all part numbers. A must-have reference for any hobbyist. Schematics are not included in parts catalogs. Includes playfield diagrams.



- |                 |             |
|-----------------|-------------|
| 4 Million B.C.  | Delta Ueen  |
| Air Aces        | El Toro     |
| Amigo           | Expressway  |
| Big Show        | Fireball    |
| Bon Voyage      | Flicker     |
| Boomerang       | Flip Flop   |
| Bow & Arrow     | Hi-deal     |
| Capt. Fantastic | Hi-lo Ace   |
| Champ           | Hokus Pokus |
| Circus          | Knockout    |

- |              |             |
|--------------|-------------|
| Little Joe   | Sea Ray     |
| Mariner      | Sky Kings   |
| Monte Carlo  | Skyrocket   |
| Nip-it       | Space Time  |
| Odds & Evens | Time Zone   |
| Old Chicago  | Twin Win    |
| Rogo         | Wizard..Is. |

#BLY1976 - Bally 1976 Parts Catalog ..... \$24.95

### 1979 PARTS CATALOG



This factory catalog contains backglass pictures, playfield diagrams, exploded views of common and game specific parts and electronic assemblies of Bally machines from 1979. It also has MPU board interchangeability charts. Covers the following machines:

- |              |                  |
|--------------|------------------|
| Freedom      | Lost World       |
| Night Rider  | Power Play       |
| Black Jack   | Strikes & Spares |
| Mata Hari    | 6 Million Dollar |
| Evel Knievel | Man              |
| 8-Ball       |                  |

#BLY1979 - Bally 1979 Parts Catalog ..... \$19.95

### 1979-1 PARTS CATALOG



This update to the 1979 catalog listed below contains the same information for the other five games released that year:

- |            |         |
|------------|---------|
| Playboy    | Kiss    |
| Supersonic | Paragon |
| Star Trek  |         |

#BLY1979-1 - Bally 1979-1 Parts Catalog ..... \$19.95

#BLY1980 - Bally 1980 Parts Catalog ..... 19.95

### 1980 PARTS CATALOG



The 1980 edition containing the same information as 1979, but covers the following machines:

- |               |                    |
|---------------|--------------------|
| Harlem        | Nitro Groundshaker |
| Globetrotters | Silverball Mania   |
| Dolly Parton  | Rolling Stones     |
| Future Spa    | Space Invaders     |

### 1980-1

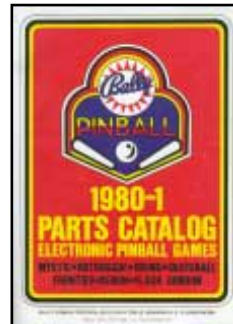

An update to the 1980 catalog, covering the rest of the machines released that year:

- |            |               |
|------------|---------------|
| Mystic     | Frontier      |
| Hotdoggin' | Xenon         |
| Viking     | Flash Gordon. |
| Skateball  |               |

#BLY1980-1 - Bally 1980-1 Parts Catalog ..... 19.95

#BLY1981 - Bally 1981 Parts Catalog ..... 19.95

### 1981



Covers machines released in 1981, in the same format as the 1979 catalog including:

- |                   |         |
|-------------------|---------|
| Eight-Ball Deluxe | Fathom  |
| Fireball II       | Medusa  |
| Embyron           | Centaur |

### 1982 PARTS CATALOG



Factory Parts catalog contains the same information as the 1979 version, but covers:

- |                    |           |
|--------------------|-----------|
| Elektra            | Spectrum  |
| Vektor             | Speakeasy |
| Rapid Fire         | B.M.X.    |
| Mr. & Mrs. Pac Man |           |

#BLY1982 - Bally 1982 Parts Catalog ..... 19.95



## BALLY/MIDWAY SERVICE BULLETINS

### 1977-80 BALLY SERVICE BULLETINS:

A 42 page collection of service bulletins addressing the earliest BALLY solid state games. Includes charts for MPU memory jumpers/combinations for the AS-2518-17 and AS-2518-35 games, recommended spare parts kit, update descriptions for the AS-2518-15/16/21 boards, early solenoid driver board modification, corrections to EIGHTBALL schematic, TE-635-2 test fixture update procedure, detailed procedure for converting AS-2518-17 MPU to AS-2518-35 MPU (electronic sound) capability, and modification of TE-633-2 test set for electronic sound.

#BLY80SB - Bally 1977-80 Service Bulletins .....\$8.95

### 1988: BALLY & MIDWAY SERVICE BULLETINS

A 50 page compilation of service bulletins pertaining to the equipment noted below and an especially useful 9 page collection of the following technical system descriptions 6803 Control Board Theory of Operation, 6809 sound board Self-test Routine, 68000 Sound Board Deluxe Self Test Routine, and the 6803 Control Board Power Up Test Sequence. Covers the following machines:

Pinball:  
 Beat The Clock      Black Belt      Hard Body      Heavy Metal  
 Motordome      Strange Science      Party Animal      8 Ball Champ

#BLY88SB - Bally/Midway Service Bulletins .....\$5.25

### BALLY 1987 SERVICE BULLETINS:

This Bally, Midway & Sente 84-page comb-bound compilation of service bulletins pertains to the equipment noted below and has an especially useful 8-page 6803 Control Board Theory of Operation section for pinball machines.

Pinball:  
 Kings Of Steel      Cybernaut      Max R.p.m.  
 Black Pyramid      8 Ball Champ      Rampage  
 Spy Hunter      Beat The Clock      Stocker  
 Fireball Classic      Motordome      Strikes & Spares  
    Black Belt      Jump Shot      Shuffle Alley.

#BLY87SB - Bally/Midway/Sente 1987 Service Bulletins \$9.95

### BLY1987 COMMON ASSEMBLIES:

90 page comb-bound companion catalog to #BLY87SB. Contains exploded diagrams and parts lists for common mechanical assemblies (flippers, thumpers, slingshots, drop targets, etc.)

#BLY87C - Bly/Mwvy/Sen 1987 Pinball Common Assemblies \$9.95

### STERN PARTS CATALOGS



This 72-page Early Stern parts catalog covers both video games and pinball machines up to 1981. Contains playfield diagrams and exploded parts assemblies for the following machines:

Lightning      Trident  
 Freefall      Hot Hand  
 Nine Ball      Meteor  
 Big Game      Galaxy  
 Sea Witch      Lectronamo  
 Star Gazer      Wild Fyre  
 Flight 200      Nugent  
 Magic      Dracula  
 Cheetah      Stingray  
 Quick Silver      Star  
 Ali      Memory Lane

#STERN81PC - Stern 1981 Parts Catalog .....\$19.95

#STERN79PC - Stern 1979 Parts Catalog .....\$19.95

## CHICAGO COIN MACHINE PARTS CATALOGS



1949: Reprint of the 20 page, comb bound CCM manual with pictorial part and assembly identification.

#CCM49 - CCM 1949 Parts Cat \$8.95

1961: Reproduction of the 100 page, comb bound CCM parts catalog with exploded diagrams and part numbers of all common CCM assemblies.

#CCM61 - CCM 1961 Parts Cat. \$12.95

1969: Reproduction of the 100 page, comb bound CCM parts catalog. Covers Pinball Machines, shuffle allies, video games, and common assemblies produced by CCM.

#CCM69 - CCM 1969 Parts Cat \$12.95

1972: Reproduction of the 100 page, comb bound CCM parts catalog with exploded diagrams and part numbers of all common CCM assemblies.

#CCM72 - CCM 1972 Parts Cat \$12.95

### BALLY 1987 PLAYFIELD PARTS GUIDE:



122 page comb-bound factory catalog has game-specific parts list and playfield photos for the following games:

Pinball:  
 Black Belt      MotorDome  
 City Slicker      Party Animal  
 Hardbody      Special Force  
 Heavy Metal      Strange Science

#BLY87P -Bally/Midway / Sente Playfield Parts Guide.....\$19.95

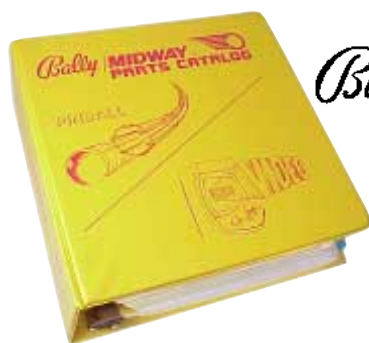

### "YELLOW BOOK" PINBALL/VIDEO PARTS CATALOG:

Documents late model BALLY pinball and MIDWAY video game machines. A 839-page factory 3" yellow loose leaf binder with about 7 lbs. of paper covering part #'s and diagrams.

Pinball:  
 Addams Family      Gilligan's Island  
 Atlantis      Harley Davidson  
 Black Rose      Mousin' Around  
 Bugs Bunny      Party Zone  
 Dr. Dude      Pool Sharks  
 Dr. Who      Radical  
 Elvira      Transporter  
 Game Show      Truck Stop.

#BLYYEL - BLY Yellow Book.....\$59.95

### Bally/MIDWAY PARTS CATALOGS



### "GRAY BOOK" PINBALL PARTS CATALOG:

A 658-page recent parts catalog, a.k.a. "the White Book", in a large 3 ring binder:

Pinball:  
 Creature From      Twilight Zone      Corvette  
 Black Lagoon      Popeye      Addams Family  
 Judge Dredd      World Cup      Gold Edition  
    Shadow      Theater Of Magic

#BLYGRY - BLY Gray Book.....\$59.95

**PinTip: Easy Lamps**

Use a ball shooter plunger tip (p.30) to help remove and install miniature lamps in tight spots.



## PARTS CATALOGS

### 1960-1980

### WILLIAMS PINBALL TROUBLESHOOTING/REFERENCE MANUAL

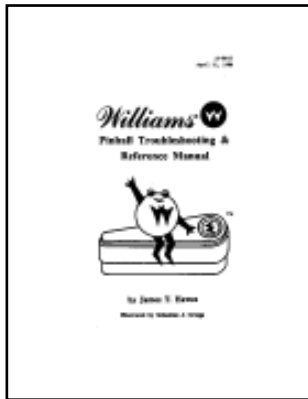

1986 factory service manual highlighting the WILLIAMS System 9 computer system. This covers games such as STAR LIGHT, SPACE SHUTTLE, SORCERER, COMET, STRIKE ZONE shuffle alley, & others. The 80 page book has extensive references to the earlier Systems 4, 6, 7, 8, & later System 11 as well as System 9 to System 11 equivalency chart. Also included are sections covering mechanical maintenance, matrix tables, and electronic and electromechanical troubleshooting flowcharts. This text is recommended for the novice pinball tech who has some electronic experience.

**#WPTP - WMS Pinball Troubleshooting Reference Manual \$18.95**

### WILLIAMS SOLID STATE FLIPPER MAINTENANCE MANUAL

This 35-page instruction manual provides identification and mechanical adjustment, game adjustment, bookkeeping, diagnostic, and troubleshooting procedures for Williams solid state flipper games (Systems 3, 4, 6) starting with Gorgar and Laser Ball. It also includes general interconnection information, as well as some handy troubleshooting charts.

**#WMS80MM - Flipper Maint. \$9.95**



### PinTip: Slick Solenoids

**Don't lubricate solenoids!**

The moving components are designed to run without additional oils or greases that act as dirt magnets and become abrasive over time. Exceptions to this rule are motors and certain mechanical assemblies.

### WILLIAMS 1960 PARTS CATALOG

64 page catalog for early WILLIAMS Electromechanical Pinball and Arcade games. Contains drawings and part numbers of common assemblies used. Covers:



3 Hole Deluxe  
Light Up Bank Pool  
All Star Baseball  
Army & Navy  
Bandwagon  
Big Ben  
C.O.D.  
Circus Wagon  
Cue Tee  
Daffy Derby  
Dealer  
Deluxe Bank Pool  
Deluxe Baseball  
Diamond Score Pool  
Four Bagger  
Grand Champion  
Gun Club  
Hot Diggitty  
Imperial Pool  
Jet Fighter  
Jolly Joker  
King of Swat  
Lazy O

Light Up Pool  
Lulu  
Major League  
Nine Sisters  
Olympic Pool  
Paisades  
Pennant Baseball  
Peppy  
Peter Pan  
Piccadilly  
Polar Hunt  
Race the Clock  
Regatta  
Royal Crown

Sr.  
Safari  
Safari Deluxe  
Score Pool  
Screamo  
Sidewalk Engineer  
Silver Skates  
Skyway  
Smoke Signal  
Snatou  
Special Deluxe Baseball  
Spirifire

Star Colors  
Star Pool  
Star Baseball  
Struggle Buggies  
Super Star Baseball  
Super Pennant Baseball  
Super Score  
Super Jet Fighter  
Surf Rider  
Three Deuces  
Thunderbird  
Tim-Buc-Tu  
Wonderland

**#WMS60 - WMS 1960 Parts Catalog ..... \$19.95**

### WILLIAMS 1962 PARTS CATALOG



This 85 page comb-bound catalog from the 60s contains parts diagrams of step units, bumper assemblies, knocker assemblies, and nearly every other common assembly in Williams machines built before 1962. It also contains a handy lubrication guide as well as a coin acceptor addendum. It covers the machines listed below:

Baseball Games  
Bowling  
(Ten Pin & Ten Strike)  
Five Ball Pames  
Gun Type

Pool Games  
Horse Race  
Games  
Roadracer

**#WMS62 - WMS 1962 Parts Catalog ..... \$22.95**

### WILLIAMS 1980 PARTS CATALOG

212 Page catalog with diagrams and parts numbers for:

Algar  
Alien Poker  
Barracora  
Black Knight  
Blackout  
Contact  
Cosmic Gunfight  
Disco Fever  
Firepower  
Flash  
Gorgar  
Hot Tip

Hyperball  
Jungle Lord  
Laser Ball  
Lucky Seven  
Pharaoh  
Phoenix  
Pokerino  
Scorpion  
Stellar Wars  
Time Warp  
Tri-zone  
World Cup



**#WMS80PC - WMS 1980 Parts Cat. .... \$19.95**

### WILLIAMS 1974-75 PARTS CATALOG

This 244 page catalog includes sections with exploded diagrams and parts numbers for WILLIAMS' flipper pinball, baseball & football, gun, horse race, bowling, shuffle alley and arcade games produced between 1969 and 1975. Especially useful is the cross referenced parts number table for interchanging units between different pinball and shuffle alley games. Machines covered:



Pinball:  
4 Aces  
Aces & Kings  
Action Baseball  
Ambush  
Ball Park  
Big Star  
Bonanza Gun  
Cabaret  
Cue T  
Dipsy Doodle  
Doodle Bug  
Expo  
Fan-Tas-Tic  
Fast Ball  
Flotilla  
Fun Fest  
Gay 90's  
Granada  
Gridiron  
Hayburner

Hit & Run  
Honey  
Jackpot & Goldrush  
Jive Time  
Jungle Drums  
Klondike  
Line Drive  
Mini Bowl  
Miss "O"  
Olympic  
Hockey  
Paddock  
Phantom Gun  
Post Time  
Ringer  
Rock & Roll  
Set Up  
Seven Up  
Smart Set  
Sniper Gun

Solids & Stripes  
Space Pilot  
Spanish Eyes  
Spooks Gun  
Stardust  
Stockade  
Straight Flush  
Strike Zone  
Super Star  
Super Star  
Suspense  
Swinger  
Travel Time  
Upper Deck  
Winner  
Yukon Special.  
Shuffle Alleys:  
Alpha  
Altair  
Amazon  
Astrodome  
Aztec

Beta  
Blazer  
Cape Cod  
Centennial  
Century  
Cimarron  
Coronado  
Delta  
El Grande  
Encore  
Epsilon  
French Quarter  
Gamma  
Gateway Arch  
Laguna  
Liberty Bell  
Orion  
Palos Verde  
Pegasus  
Tango

Times Square  
Windy City  
Gun games:  
Ambush Gun  
Jungle Drums  
Sniper Gun  
Stockade Gun.  
Horse race:  
Winner  
Baseball & Football:  
Action Baseball  
Line Drive  
Hit & Run  
Upper Deck  
Fast Ball  
Gridiron  
Arcade games:  
Mini-Bowl  
Flotilla.

**#WMS75 - WMS 1975 Parts Catalog ..... \$26.95**

### WILLIAMS 1977-78 PARTS CATALOG

This is a 142 page manual covering WILLIAMS / UNITED pingames, baseball & gun games, and shuffle alleys. Contains a lubrication guide, alphabetical index of assembly descriptions, and listing of games by production dates from Jan. 1972 thru Dec. 1976. Includes parts info for the following machines:

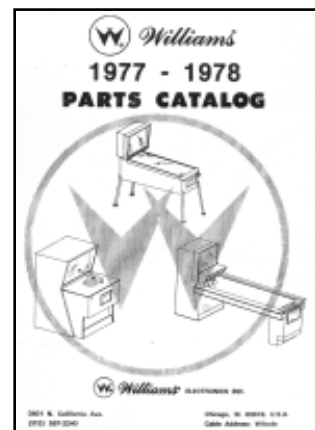

Pinball:  
Stardust  
Big Star  
Fan-tas-tic  
Swinger  
Travel Time  
Fun Fest  
Tropic Fun  
Gulfstream  
Jubilee  
Darling  
Oxo  
Star Action  
Triple Action  
Dealers Choice  
Skylab  
Strato-flite  
Super Flite

Lucky Ace  
Star Pool  
Satin Doll  
Big Ben  
Pat Hand  
Triple Strike  
Little Chief  
Toledo  
Space Mission  
Space Odyssey  
Aztec  
Blue Chip  
Grand Prix  
Granada  
Honey  
Olympic Hockey  
Spanish Eyes

Super Star  
Baseball Games:  
Line Drive  
Upper Deck  
Gun Games:  
Stockade  
Ambush  
Shuffle Alleys:  
Windy City  
French Quarter  
Gateway Arch  
Astrodome  
Cape Cod

Golden Triangle  
Twin Cities  
Royal Hawaii  
Pinnacle  
Granite  
Civic Center  
Unique  
Supreme  
Marquis  
Star Sapphire  
Seville  
Emerald  
Cavalier.

**#WMS78 - WMS 1977-78 Parts Catalog ..... \$21.95**

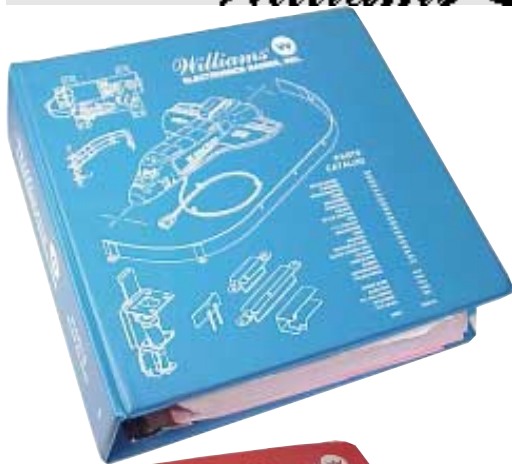

## PARTS CATALOGS 1989 TO 1994 WILLIAMS "BLUE BOOK" PARTS CATALOG

This 670-page factory blue 3" loose leaf binder includes complete part # listings and diagrams for the following games:

- |   |  |  |  |
|---|--|--|--|
| <b>Pinball</b><br>Banzai Run<br>Big Guns<br>Black Knight 2000<br>Comet<br>Cyclone<br>Earth Shaker | <b>F-14 Tomcat</b><br>Fire!<br>Grand Lizard<br>High Speed<br>Jokerz<br>Millionaire<br>Pinbot | <b>Police Force</b><br>Road Kings<br>Sorcerer<br>Space Station<br>Space Shuttle<br>Swords of Fury<br>Taxi. | <b>Shuffle Alleys:</b><br>Alley Cats<br>Gold Mine<br>Strike Zone<br>Tic Tac Strike<br>Top Dawg.<br>Video:<br>NARCS |
|---|--|--|--|

#WMSBLUE - WMS Blue Book ..... \$59.95

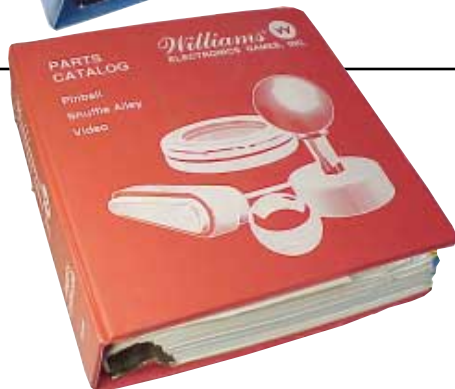

## WILLIAMS "RED BOOK" PARTS CATALOG

A 852-page factory parts catalog documenting WILLIAMS games. A fat red 3" loose leaf binder detailing the latest WILLIAMS pinball, shuffle alley, and video games, including:

- |   |  |  |   |
|---|--|--|---|
| <b>Pinball</b><br>Bad Cats<br>Diner<br>Dracula<br>Fish Tales<br>Funhouse<br>Getaway | <b>Hurricane</b><br>Riverboat Gambler<br>Rollergames<br>Terminator 2<br>The Machine<br>Whirlwind | <b>Shuffle Alleys</b><br>Shuffle Inn<br>Shuffle Inn Deluxe<br>& Jr.<br>Strike Master & Jr. | <b>Video games:</b><br>High Impact<br>Hit The Ice<br>Smash TV<br>Sports games<br>Slugfest<br>Hot Shot |
|---|--|--|---|

#WMSRED - WMS 1992 Red Book ..... \$59.95

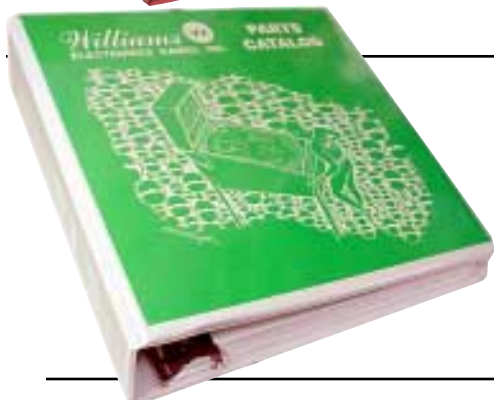

## WILLIAMS "GREEN BOOK" PARTS CATALOG:

The last parts catalog published in a large 3 ring binder contains 444 pages of parts diagrams and part numbers for the following machines:

- |  |   |
|--|---|
| <b>Pinball:</b><br>Indiana Jones<br>Star Trek Next Generation<br>Road Show | <b>Demolition Man</b><br>The Flintstones<br>Dirty Harry |
|--|---|

#BLYGRN - BLY Green Book ..... \$59.95

## WPC INFO

### WPC THEORY OF OPERATION & SCHEMATICS

If you're fortunate enough to own a late model WILLIAMS pinball machine and want an in-depth understanding of how it works, this 1991 WILLIAMS Tech Support document is for you. It contains 60 pages of set-up, system & circuit operation and troubleshooting info plus an additional 14 large circuit schematics. WPC games (WILLIAMS Pinball Controller) are listed on page 28 in the revisions chart.

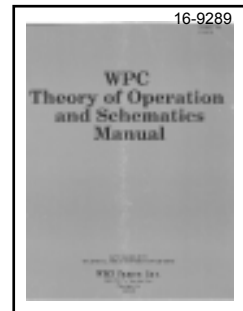

#WPC9289 - WPC Theory & Schem. \$19.95

### 1993 WPC SCHEMATICS

This 1993 schematic supplement details the following assembly descriptions & changes: Power wiring diagram, CPU Board schematic, Power Driver Board schematic, Dot Matrix Controller Board, Dot Matrix Display Board (BABCOCK & CHERRY brands), Fliptronic II board, Sound Board schematic (pre & post Ma 1993). 20 ledger sized diagrams.

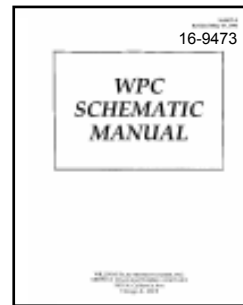

#WPC9473 - WPC Schematics .... \$16.95

### 1994 WPC SCHEMATIC MANUAL

This 20 page set of ledger size, factory drawings detail Power Wiring diagrams, Pre 4/94 CPU (Security Board) diagrams, Power Driver board, Dot Matrix controller Board, BABCOCK & CHERRY display driver boards, FLIPTRONIC II board, and Sound Board schematics. WMS #16-9834.2

#WPC9834 - WPC Schematics \$9.95

### WPC-95 SCHEMATIC MANUAL

This 20 page set of ledger size, factory drawings detail the latest Power Wiring diagrams, Pre & Post 4/94 CPU (Security Board) diagrams, Power Driver board, Dot Matrix controller Board, BABCOCK & CHERRY display driver boards, FLIPTRONIC II board, and Sound Board schematics. WMS #16-10159.3

#WPC10159 - WPC-95 Schematics \$9.95



## PINBALL SERVICE BULLETIN BOOK

This collection of service bulletins covers Sega, Stern, and Data East machines from Early 1988 to 2000. The three-ring binder is packed full of bulletins concerning modifications, settings, software options, adjustments, and more for Sega (Now known as Stern) and Data East machines. Machines covered in this collection include:

- |   |   |   |   |
|---|---|---|---|
| ABC Monday Night<br>Back to the Future<br>Batman<br>Checkpoint<br>Football<br>Guns N' Roses | Hook<br>Jurassic Park<br>Last Action Hero<br>Laser War<br>Lethal Weapon 3<br>Maverick | Phantom of the Opera<br>Playboy 35th Anniversary<br>Robocop<br>Secret Service<br>The Simpsons<br>Star Trek 25th Anniversary | Star Wars<br>Rocky & Bullwinkle<br>Tales from the Crypt<br>The Who's Tommy<br>Time Machine<br>Wacky Gator |
|---|---|---|---|

#SEGASB - SEGA/Stern/D.E. Service Bulletins ..... \$24.95







# Factory Literature

# D. Gottlieb & Co.

## Service

### SYS.1 SOLID STATE PINBALL SERVICE MANUAL - 1ST ED.

The 34 page technical service manual that applies to the games listed below but with emphasis on waveform pictures, detailed theory of operation, and schematic diagrams.

**#GOTSRV1 Gottlieb Sys. 1--1st Ed. \$14.95**

### SYS.1 SOLID STATE PINBALL SERVICE MANUAL - 2ND ED.

This 92 page factory service manual covers the first GOTTLIEB electronic pinball games. The System 1 is designed around the Rockwell PPS-4/2 micro-processor and was used in the games:

Asteroids Annie	Close Encounters	Hulk	Sinbad
Buck Rogers	Countdown	Joker Poker	Solar Ride
Charlie's Angels	Dragon	Pinball Pool	Torch
Cleopatra	Genie	Roller Disco	Totem

Contains theory of operation, troubleshooting guides, electronic components list, component location diagrams & schematics.

**#GOTSRV2 - Gottlieb Sys.1,2nd Ed. \$19.95**  
**#GOTCOMBO - 1st & 2nd editions \$29.95**

### SYS. 80 SERVICE MANUAL



The 60 page factory manual covering GOTTLIEB electronic System 80 Operation, Troubleshooting, Theory of Operation, Component level repair, Schematics & Parts Lists, cable connector wire assignments, and System 80 LSI devices. Shows test point scope displays.

**#GOTSRV80 - Sys.80 Service Manual \$16.95**

## Parts Catalogs

### GOTTLIEB 1957 PARTS CATALOG

This 40 page document contains pictorial diagrams along with part numbers, adjustments, and lubrication instructions for vintage GOTTLIEB pinball machine common assemblies prior to 1957. Also has a parts price list from a bygone era. This catalog covers the following games:

All Star Basketball	Hawaiian Beauty
Arabian Knights	Harbor Lites
Chinatown	Hit N'Run
Classy Bowler	Jockey Club
Coronation	Jubilee
Crossroads	Jumbo
Daisy May	Lady Luck
Derby Day	Lovely Lucy
Diamond Lil	Marathon
Dragonette	Marble Queen
Etouette	Mystic Marvel
Easy Aces	Niagara
Flying High	Pin Wheel
Four Belles	Poker Face
Four Stars	Quartette
Frontiersman	Queen of Hearts
Gladiator	Quintette
Globe Trotter	Rose Bowl
Gold Star	Score Board
Grand Slam	Sea Belles
Green Pastures	Shindig
Guys & Dolls	Skill Pool
Gypsy Queen	Sluggin' Champ
Happy Days	Southern Belle



Stage Coach	Twin Bill
Sweet Add-A-Line	Wild West
Treador	Wishing Well
Tournament	

**#GOT57 - Gottlieb 1957 Parts Catalog ..... \$19.95**

### GOTTLIEB 1966 PARTS CATALOG - VOL. H

A 128 page book with same information as earlier volume but covers the following machines:



Aloha	Lancers
Big Casino	Liberty Belle
Big Top	Majorettes
Bonanza	North Star
Bowling Queen	Oklahoma
Corral	Olympics
Cover Girl	Preview
Egg Head	Rack-A-Ball
Fashion Show	Sea Shore
Flipper Clown	Ship Mates
Flipper Parade	Show Boat
Flipper Cowboy	Slick Chick
Flipper Fair	Square Head
Flying Chariots	Sunset
Flying Circus	Sweet Hearts
Foto Finish	Swing-Swing-A-Long
Gauche	Tropic Isle
Gigi	World Fair
Happy Clown	

**#GOT66 - Gottlieb 1966 Parts Catalog ..... \$24.95**

### GOTTLIEB 1968 PARTS CATALOG - VOL. J

A 166 page book with same information as listed above but covers the following machines:

Gauche	Dodge City
Squank-a-ball	Flipper Pool
Square Head	Electra Pool
Wing-a-long	Paradise
Sweethearts	Pleasure Isle
Flying Chariots	Ice Revue
Gigi	Masquearde
Big Top	Ice Show
Ship Mates	Central Park
World Fair	Hurdy Gurdy
Bonanza	Mayfair
Bowling Queen	Hyde Park
Majorettes	Rancho
Sea Shore	Crosstown
North Star	Subway
Happy Clown	Dancing Lady
Sky Liine	King Of Diamonds
Thorobred	Solitaire
Kings & Queens	Hit-a-card
Hi Dolly	Diamond Jack
Buckaroo	Super Score
Cow Poke	



Hi-score	Troubadour
Super Duo	Surf Side
Harmony	Sea Side
Sing Along	

**#GOT68 - Gottlieb 1968 Parts Catalog ..... \$24.95**



### GOTTLIEB 1978 PARTS CATALOG

Contains the playfield diagrams and sub-assembly break downs for the following games:

"300"/Top Scor	Far Out!	Jet Spin/Super	Soccer
Abra Ca Dabra	Out Of Sight	Spin	Spin Out
Atlantis	Fast Draw!	Jungle Queen!	Spirit Of '76!
Big Hit	Quick Draw	Jungle Princess	Pioneer
Big Indian!	High Hand	Magnatron!	Sure Shot
Big Brave	Hot Shot!Big	Duotron	Surf Hamp/Surfer
Bronco/Mustang	Shot	Pro Football	Target Alpha/Solar
Buccaneer	Ing Pin	Royal Flush!	City
Canada Dry	Jack In The Box	Card Whiz	Top Card
Centigrade 37	/Jumping Jack	Sky Jump	Volley
El Dorado	Jacks Open	Soccer/Super	

**#GOT78 - Gottlieb 1978 Parts Catalog ..... \$17.95**

### GTB 1970 PARTS CATALOG - VOL. K

A 152 page book with same information as listed above but covers the following machines:

Royal Guard	Spin-A-Card
Elite Guard	Hi-Lo
Palace Guard	Hearts & Spades
Fun Land	Airport
Fun Fair	College Queens
Tivoli	Bumper Pool
Fun Park	Target Pool
Big Jack	Mini Pool
Paul Bunyan	Wild Wild West
Domino	Super Bowl
Grande Domino	Milks
Playmates	Skipper
Four Seasons	

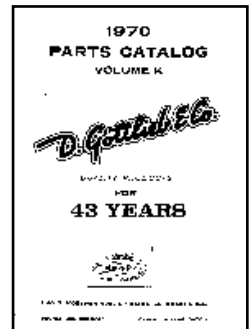

**#GOT70 - Gottlieb 1968 Parts Catalog ..... \$24.95**

### GOTTLIEB 1976 PARTS CATALOG



166 Page comb bound catalog listing assy #'s and exploded assy. views for the following games:

Astro	Now
Bristol Hills	Orbit
Card King	Outer Space
Challenger	Playball
Dimension	Play Pool
Drop-a-card	Pop A Card
Extra Inning	Roller Coaster
4 Square	Sheriff
Flying Carpet	Snow Derby
Galaxie	Space Orbit
Grand Slam	Star Trek
Home Run	Texas Ranger
Jungle	2001
King Rock	World Series
Lawman	Wild Life

**#GOT76 - Gottlieb 1976 Parts Catalog ..... \$24.95**

# Factory Literature



## GTB 1980 PARTS CATALOG

76 Page catalog with common assemblies, game specific part numbers, and exploded diagrams for the following machines:

- |                  |            |                 |            |
|------------------|------------|-----------------|------------|
| Charlie's Angels | Count Down | Incredible Hulk | Sinbad     |
| Cleopatra        | Dragon     | Joker Poker     | Solar Ride |
| Close Encounters | Genie      | Pinball Pool    | Totem      |

#GOT80 - Gottlieb 1980 Parts Catalog ..... \$13.95

## GTB 1982 PARTS CATALOG

142 page catalog with common assemblies, game specific part numbers, and exploded diagrams for the following machines:

- |                  |                |
|------------------|----------------|
| Cleopatra        | Circus         |
| Sinbad           | Panthera       |
| Joker Poker      | Asteroid Annie |
| Close Encounters | Counterforce   |
| Dragon           | Star Race      |
| Charlie's Angels | James Bond     |
| Solar Ride       | Time Line      |
| Countdown        | Force li       |
| Pinball Pool     | Pink Panther   |
| Totem            | Mars           |
| Hulk             | Volcano        |
| Genie            | Black Hole     |
| Roller Disco     | Haunted House  |
| Buck Rogers      | Devil's Dare   |
| Torch            | Caveman        |
| Spiderman        | Rocky          |



#GOT82 - GTB 1982 Parts Catalog ..... \$18.95

## GTB/PREMIER 1987 PARTS CATALOG

172 page catalog featuring playfield diagrams, exploded assembly views, parts lists, & manual addenda for the following games:

- |                |                    |
|----------------|--------------------|
| Alien Star     | Ready Aim Fire     |
| Amazon Hunt    | Rock Encore        |
| Black Hole     | Rock               |
| Bounty Hunter  | Rocky              |
| Chicago Cubs   | Royal Flush Deluxe |
| Devil's Dare   | Spirit             |
| El Dorado      | Striker            |
| Haunted House  | Super Orbit        |
| Hollywood Heat | Tag Team           |
| Ice Fever      | The Games          |
| Jacks to Open  | Touchdown          |
| Punk           | Triple Play        |
| Q*Bert's Quest | Volcano            |
| Rack 'Em Up    | Genesis            |
| Raven          |                    |



#GOT87 - GTB 1987 Parts Catalog ..... \$19.95

# D. Gottlieb & Co.

## Parts Catalogs 1980 TO 1995

### GTB/PREMIER 1992 PARTS CATALOG



202 page catalog contains parts information plus technical service bulletins. Has an especially useful chart for decoding coil windings gauge & turns by part #. Games covered are:

- |              |                  |
|--------------|------------------|
| Gold Wings   | Bonebusters      |
| Monte Carlo  | Lights..Camera.. |
| Spring Break | Action!          |
| Arena        | Silver Slugger   |
| Victory      | Vegas            |
| Diamond Lady | Deadly Weapon    |
| TX Sector    | Title Fight      |
| Robo-War     | Car Hop          |
| Excalibur    | Hoops            |
| Bad Girls    | Cactus Jack's    |
| Hot Shots    | Class of 1812    |
| Big House    |                  |

#GOT92 - GTB/Premier 1992 Parts Catalog ..... \$19.95

### GTB/PREMIER 1995 PARTS CATALOG

This 172 page comb bound book contains playfield diagrams, exploded assembly drawings with part #'s, System 3 Test Fixture information, and technical service bulletins for the latest GOTTLIEB games including:

- |                   |                   |
|-------------------|-------------------|
| Surf'n Safari     | Gladiators        |
| Operation Thunder | Wipe Out          |
| Super Mario Bros. | World Challenge   |
| Mushroom World    | Soccer            |
| Cue Ball Wizard   | Rescue 911        |
| Street Fighter 2  | Freddy - A Night- |
| Tee'd Off         | mare On Elm St    |



#GOT95 - GTB/Premier 1995 Parts Catalog ..... \$19.95

## GTB SERVICE BULLETINS SYSTEM 80 TECHNICAL UPDATES (1987)

This 24 page factory bulletin collection covers: machine set-up procedures; pinball game/number listing, System 80A/B overview, board revisions, & percentaging; drop target modifications; MA-766 & 886 sound board theory of operation; wire color code chart & GENESIS, GOLD WING, SPRING BREAK, & ARENA service bulletins.

#GOTSB87 - System 80 Updates ..... \$5.00

## SYSTEM 3 TECHNICAL UPDATES (1993)

A 25 page, factory compiled group of service bulletins addressing problems in the following games:

- |                   |                   |                 |
|-------------------|-------------------|-----------------|
| Super Mario Bros. | Bonebusters       | Class Of 1812   |
| Mushroom World    | Operation Thunder | SILVER SLUGGER. |
| Street Fighter 2  | Surf'n Safari     |                 |
| Cue Ball Wizard   | Cactus Jack       |                 |

#GOTSB93 - 1993 Sys.3 Tech Updates ..... \$5.00

#GOTSB94 - GTB 1994 Service Bulletins ..... \$5.00

#GOTSB95 - GTB 1995 Service Bulletins ..... \$5.00



## 1995 SERVICE BULLETINS

This 36 page collection of 1995 service bulletins covers CAPCOM's pinball and video games. The topics covered are: PINBALL MAGIC CPU software version 1.01; 1.02; 1.03; 1.06, CPU LED Error code, orbit shot, mechanical coin meter, dot display, switch resistor removal, ball falls into cabinet, troubleshooting error messages, replay score level and PCB version compatibility. Also includes videogame topics: NIGHTWARRIORS manual corrections, STREET FIGHTER THE MOVIE pwr. supply voltage, part #'s, MARVEL SUPER HEROES game features / maximizing revenues, and STREET FIGHTER ALPHA maximizing revenues.

#CAP95 - Capcom 1995 Bullitens \$6.95

## 1996 SERVICE BULLETINS

A 56 page compilation of service bulletins and technical information regarding: PINBALL MAGIC software revisions 1.0.8 & 1.0.9, power supply fuse F9; flipper strength adjustment; drop target revision, flipper EOS actuator revision, electronic systems compatibility, pinball ROM sizes and location chart, stage door plunger link modification, opto printed circuit boards, AIRBORNE software revisions 1.0.0, 1.1, 1.2, 1.3, 1.4, 1.6, left up/down ramp, BREAKSHOT software revisions 2.0, intermittent slam-tilt on power up, power driver and power supply PCB mis-wiring, backbox thumb-screws, manual amendment, hand-rail lock compatibility chart, BIG BANG BAR beta software rev. 1.5 & 1.6, GOOFOY HOOPS display flicker.

#CAP96 - Capcom 1996 Bulletins \$7.95



## DIAGNOSTIC INFORMATION

The 12 page booklet contains schematic diagrams, diagnostic test instructions, switch identification codes, and hardware revisions for most ALLIED upright and cocktail table pinball machines, including:

- |                 |              |              |
|-----------------|--------------|--------------|
| Disco 79        | Hoe Down     | Super Picker |
| Eros One        | Roy Clark    | Take Five    |
| Hearts & Spades | Star Shooter | Thunderbolt. |

#ALLP - Allied Leisure ..... \$8.95



**PinTip:  
Playfield Angles**

Measure the incline of your pinball machine on the **playfield**, not on the playfield glass. The pitch of the glass varies from game to game depending on the height of the features inside. The **average tilt** of a pinball machine is 6-1/2 degrees.



# Rubber Rings

## RUBBER RING KITS

Why waste time ripping your playfield apart, removing the old rubber, and measuring each ring? Order the **Rubber Ring Kit for Your Machine!** Specify machine name and manufacturer when ordering.

Each kit includes, if applicable:

- Rubber rings
- Post sleeves
- Flipper rubbers
- Rebound Rubber
- Post Sleeves
- Shooter Tip

**#RK - Ring Kit (Specify Machine, Mfr) ..... \$13.95**

**#RKD - Double Playfield/Wide Body ..... \$17.95**



**PinTip:**  
Rubber Sunburn

Don't store your white rings under fluorescent lamps. The UV exposure turns them yellow over time.

**Rubber Ring Gauge**

Simply cut on the dotted line, wrap around either the posts of your machine or the old ring (on the inside) to find out your ring size.

## WHITE RUBBER RINGS

Marco #	Ring Size ID	Type	Color	Bally #	Gottlieb #	Early Stern #	Williams #	Stern/ Sega/DE#	Price
38-2364	23/64" or 3/8" OD	Mini-Post	White	R-206-11	A-14793	7A-125	23-6626	545-5025-19	<b>\$.25</b>
38-2764	27/64" or 7/16" OD	Mini-Post	White	R-521-11	A-15705	7A-135	23-6535	545-5025-17	<b>.25</b>
38-0316	3/16"	Steel Post	White	17-41-641	-----	-----	23-6641-1	545-5025-1	<b>.25</b>
38-0516	5/16"	Plastic Post	White	R-243	A-10217	7A-120-031	23-6300	545-5025-02	<b>.25</b>
38-0038	3/8"	Ring	White	-----	A-10217	-----	23-6591	-----	<b>.30</b>
38-0716	7/16"	Ring	White	-----	A-17493	-----	23-6599	545-5025-18	<b>.43</b>
38-0034	3/4"	Ring	White	R-521	A-10218	-----	23-6301	545-5025-04	<b>.29</b>
38-1000	1"	Ring	White	R-521-1	A-10219	7A-120-100	23-6302	545-5025-05	<b>.29</b>
38-1250	1 1/4"	Ring	White	R-521-1	A-10219	7A-120-125	23-6303	545-5025-06	<b>.40</b>
38-1500	1 1/2"	Ring	White	R-521-2	A-10220	7A-120-150	23-6304	545-5025-07	<b>.45</b>
38-2000	2"	Ring	White	R-521-3	A-10221	7A-120-200	23-6305	545-5025-08	<b>.45</b>
38-2500	2 1/2"	Ring	White	R-521-4	A-10222	7A-120-250	23-6306	545-5025-09	<b>.49</b>
38-2750	2 3/4"	Ring	White	-----	-----	-----	-----	545-5025-20	<b>.49</b>
38-3000	3"	Ring	White	R-521-5	A-10223	7A-120-300	23-6307	545-5025-10	<b>.55</b>
38-3500	3 1/2"	Ring	White	R-521-6	A-10224	7A-120-350	23-6308	-----	<b>.59</b>
38-4000	4"	Ring	White	R-521-7	A-10225	7A-120-400	23-6309	-----	<b>.65</b>
38-4500	4 1/2"	Ring	White	R-521-8	A-10226	7A-120-450	23-6530	545-5025-13	<b>.99</b>
38-5000	5"	Ring	White	R-521-9	A-10227	7A-120-500	23-6310	-----	<b>1.25</b>
38-5500	5 1/2"	Ring	White	R-521-10	A-10228	7A-120-550	-----	-----	<b>1.59</b>
38-6000	6"	Ring	White	R-521-11	A-10229	7A-120-600	-----	-----	<b>2.00</b>

## BLACK RUBBER RINGS

Marco #	Ring Size ID	Type	Color	Bally #	Gottlieb #	Early Stern #	Williams #	Stern/ Sega/DE#	Price
38-2364B	23/64" or 3/8" OD	Mini-Post	Black	-----	-----	-----	-----	545-5348-19	<b>\$.25</b>
38-2764B	27/64" or 7/16" OD	Mini-Post	Black	-----	-----	-----	23-6694-1	545-5348-17	<b>.25</b>
38-0316B	3/16"	Steel Post	Black	-----	-----	-----	23-6641	545-5348-01	<b>.25</b>
38-1564B	15/64"	Steel Post	Black	-----	-----	-----	23-6694-2	-----	<b>.49</b>
38-0516B	5/16"	Ring	Black	-----	-----	-----	23-6694-3	545-5348-02	<b>.25</b>
38-0038B	3/8"	Ring	Black	-----	-----	-----	-----	545-5348-03	<b>.30</b>
38-0716B	7/16"	Ring	Black	-----	-----	-----	23-6694-4	545-5348-18	<b>.43</b>
38-0034B	3/4"	Ring	Black	-----	-----	-----	23-6694-5	545-5348-04	<b>.29</b>
38-1000B	1"	Ring	Black	-----	-----	-----	23-6694-6	545-5348-05	<b>.29</b>
38-1250B	1-1/4"	Ring	Black	-----	-----	-----	23-6694-7	545-5348-06	<b>.40</b>
38-1500B	1-1/2"	Ring	Black	-----	A-10220Y	-----	23-6694-8	545-5348-07	<b>.45</b>
38-1750B	1-3/4"	Ring	Black	-----	-----	-----	-----	545-5348-21	<b>.99</b>
38-2000B	2"	Ring	Black	-----	-----	-----	23-6694-9	545-5348-08	<b>.45</b>
38-2500B	2-1/2"	Ring	Black	-----	A-10222Y	-----	23-6694-10	545-5348-09	<b>.49</b>
38-2750B	2-3/4"	Ring	Black	-----	-----	-----	-----	545-5348-20	<b>.49</b>
38-3000B	3"	Ring	Black	-----	-----	-----	23-6694-11	545-5348-10	<b>.55</b>
38-3500B	3-1/2"	Ring	Black	-----	-----	-----	23-6694-12	545-5348-11	<b>.59</b>
38-4000B	4"	Ring	Black	-----	-----	-----	23-6694-13	545-5348-12	<b>.65</b>
38-4500B	4-1/2"	Ring	Black	-----	-----	-----	26-6694-14	545-5348-13	<b>.99</b>
38-5000B	5"	Ring	Black	-----	-----	-----	26-6694-15	545-5348-14	<b>1.25</b>

©2000 Marco Specialties, Inc. All rights reserved.

**Marco Specialties Inc.**

803-957-5500

www.pinballmachine.com

fax: 803-957-6974



# Rubber Rings

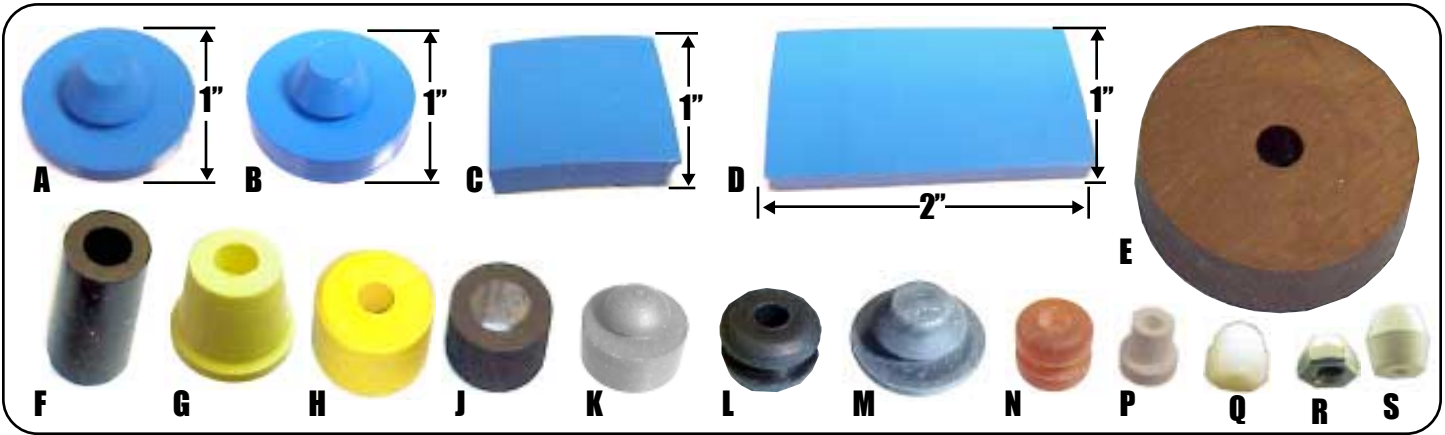

## MISCELLANEOUS RUBBER

Fig	Marco #	Description	Color	Bally #	Gottlieb #	Early Stern #	Williams #	Stern/ Sega/DE#	Price
A	38-6702	Round 1" bumper pad thin	Blue	.....	.....	.....	23-6702	.....	1.25
B	38-6686	Round 1" bumper pad thick	Blue	.....	.....	.....	23-6686	.....	1.25
C	38-6629	Square adhesive back bumper pad	Blue	.....	.....	.....	23-6629	.....	1.75
D	38-6674	1" x 2" Rect adhesive bumper pad	Blue	.....	.....	.....	23-6674	.....	6.00
-	38-115-4	Rebound Rubber, 1-1/4" O.D.	White	R-115-4	.....	.....	.....	.....	1.60
E	38-1344	Rebound Rubber, 1-1/2" O.D.	Brown	.....	A-1344	7A-113	.....	.....	1.60
F	38-6552	7/8" tall Post Sleeve	Yellow	.....	A-26648Y	.....	23-6552	.....	.60
F	38-6552-1	7/8" tall Post Sleeve	Black	.....	.....	.....	23-6552-1	545-5009-00	.60
F	38-6556	1-1/16" tall Post Sleeve	Black	.....	.....	.....	23-6556	545-5260-00	.50
G	38-6579-1	Tapered Rubber	Black	.....	.....	.....	23-6579-1	.....	1.40
G	38-6579	Tapered Rubber	Yellow	.....	.....	.....	23-6579	.....	1.50
H	38-6551	Rubber Bumper	Yellow	.....	.....	.....	23-6551	.....	1.75
J	38-5151	3/8" ID Bumper	Black	.....	.....	.....	.....	545-5151-00	1.00
K	38-6313-1	Grommet plug	Black	.....	.....	.....	23-6313-1	545-5105-00	.25
L	38-111-39	Bally Chime Grommet	Black	R-111-39	.....	.....	.....	.....	.80
M	38-6577	Bumper Plug	Black	.....	.....	.....	23-6577	.....	.50
N	38-6420	Grommet	Amber	.....	.....	.....	23-6420	.....	.25
P	38-6425	T-Rubber	White	.....	.....	.....	23-6425	.....	.25
Q	38-6543N	Nylon Post Cap	White	.....	.....	.....	.....	.....	.30
R	38-6543C	Chrome Post Cap	Chrome	.....	.....	.....	.....	.....	.45
S	38-6543	Post Cap	White	R-412	E-15	.....	23-6543	.....	.30

## FLIPPER RINGS & SHOOTER TIPS

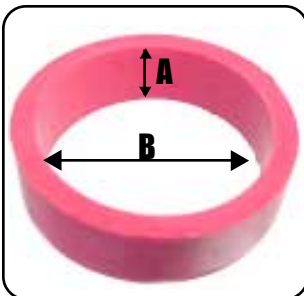

Marco #	Dim A	Dim B	Type	Color	Bally #	Gottlieb #	Early Stern #	Williams #	Stern/ Sega/DE#	Price
38-6519-4	1/2"	1-1/2"	Standard	Red	R-406-3; R-533-3	A-13151	7A-121-R	23-6519-4	.....	1.05
38-6519-6	1/2"	1-1/2"	Standard	Yellow	R-521-11	.....	7A-121-Y	23-6519-6	545-5277-06	1.15
38-6695	1/2"	1-1/2"	Standard	Black	.....	28546	.....	23-6695	545-5277-00	1.05
38-6553-4	1/2"	1"	Small	Red	.....	A-13149	7A-142	23-6553-4	.....	1.00
38-6553-6	1/2"	1"	Small	Yellow	.....	.....	.....	23-6553-6	545-5207-00	1.00
38-122B	1/2"	1"	Small	Black	.....	.....	.....	.....	.....	1.00
38-10801	3/8"	1-1/2"	Gottlieb	Yellow	.....	A-13151	.....	.....	.....	1.00
38-10802	3/8"	1-1/2"	Gottlieb	Red	.....	A-13151	.....	.....	.....	1.00



Marco #	Color	Bally #	Gottlieb #	Early Stern #	Williams #	Stern/ Sega/DE#	Price
38-1100	Brown	R-108-4	.....	.....	.....	545-5027	.49
38-1100B	Black	.....	.....	.....	23-6327	545-5276-00	.49
38-1100W	White	.....	.....	.....	.....	.....	.49
38-1100T	Tan	.....	.....	.....	.....	.....	.49



# Light Bulbs

## EIKO MINIATURE LAMPS

Bulbs shown actual size

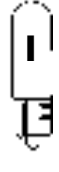
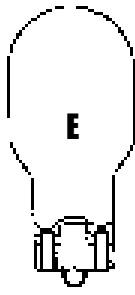
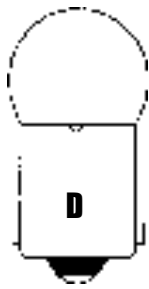
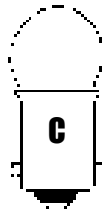
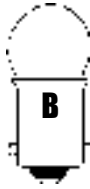

- Top quality EIKO lamps
- Exact replacements
- Packaged 10 to a box

Item #	Bulb	Fig	Volts	Base	Price/10	Price/100
04-0012	#12	A	6.3	2-Prong	\$18.70	\$168.30
04-0019	#19	B	14.4	2-Prong	19.00	171.00
04-0037	#37	I	14.0	Wedge	5.70	51.30
04-0040	#40	J	6.3	Screw	4.70	42.30
04-0044	#44	A	6.3	Bayonet	3.00	\$15.00
04-0046	#46	J	6.3	Screw	4.40	39.60
04-0047	#47	A	6.3	Bayonet	3.00	\$15.00
04-0050	#50	B	7.5	Bayonet	4.40	39.60
04-0051	#51	B	7.5	Bayonet	3.40	30.60
04-0052	#52	B	14.4	Bayonet	4.80	43.20
04-0053	#53	B	14.4	Bayonet	4.40	39.60
04-0055	#55	C	7	Bayonet	4.30	38.70
04-0057	#57	B	14	Bayonet	4.50	40.50
04-0063	#63	D	7	Med. Bayonet	4.50	40.50
04-0067	#67	D	13.5	Med. Bayonet	4.10	36.90
04-0073	#73	I	14	Sub Mini Wedge	5.70	51.30
04-0074	#74	I	14	Sub Mini Wedge	7.00	63.00
04-0081	#81	D	6.5	Med. Bayonet	6.00	54.00
04-0086	#86	I	6.3	Sub Mini Wedge	4.20	37.80
04-0088	#88	-	6.8	D.C. Bayonet	5.70	51.30
04-0089	#89	D	13	Med. Bayonet	5.30	47.70
04-0130	#130	B	6.3	Bayonet	5.40	50.00
04-0147	#147	A	7.0	Bayonet	5.60	50.40
04-0158	#158	F	14	Wedge	4.00	36.00
04-0159	#159	F	6.3	Wedge	3.00	27.00
04-0161	#161	F	14	Wedge	4.60	41.40
04-0168	#168	F	14	Wedge	4.60	41.40
04-0192	#192	F	13	Wedge	5.40	48.60
04-0193	#193	F	14	Wedge	6.50	58.50
04-0194	#194	F	14	Wedge	3.90	35.10

Item #	Bulb	Fig	Volts	Base	Price/10	Price/100
04-0222	#222	-	2.25	Screw	4.80	43.20
04-0257	#257	B	14	Bayonet	6.20	55.80
04-0259	#259	F	6.3	Wedge	4.50	40.50
04-0303	#303	D	28	Med. Bayonet	9.10	81.90
04-0313	#313	A	28	Bayonet	5.40	48.60
04-0455	#455	B	6.3	Bayonet	7.00	63.00
04-0555	#555	F	6.3	Wedge	3.00	15.00
04-0585	#585	F	28	Wedge	5.50	49.50
04-0656	#656	F	28	Wedge	5.50	49.50
04-0657	#657	F	28	Wedge	6.40	57.60
04-0658	#658	-	14	Wedge	5.50	49.50
04-0755	#755	A	6.3	Bayonet	6.70	60.30
04-0756	#756	A	14.0	Bayonet	6.70	60.30
04-0757	#757	A	28.0	Bayonet	6.70	60.30
04-0906	#906	E	13	Wedge	4.90	44.10
04-0912	#912	E	12.8	Wedge	4.70	42.30
04-1129	#1129	-	6.4	Med. Bayonet	9.50	85.50
04-1251	#1251	D	28	Med. Bayonet	5.60	50.40
04-1449	#1449	J	14.0	Bayonet	4.40	39.60
04-1683	#1683	-	28	Med. Bayonet	11.20	100.80
04-1813	#1813	A	14.4	Bayonet	5.70	51.30
04-1843	#1843	A	-	Bayonet	13.00	117.00
04-1847	#1847	A	6.3	Bayonet	4.40	39.60
04-1891	#1891	A	14.0	Bayonet	5.10	45.90
04-1892	#1892	A	14.4	Bayonet	5.30	47.70
04-1895	#1895	C	14.0	Bayonet	4.70	42.30
04-2181	#2181	H	6.3	Wire terminal	4.60	41.40
04-2182	#2182	H	14	Wire terminal	4.80	43.20
04-7373	#7373	G	14.0	Bi-pin terminal	10.40	93.60
04-7381	#7381	G	6	Bi-pin terminal	9.40	84.60

### SPECIAL

100 bulbs: \$15!

Your choice of:  
#44, #47, or #555 lamps!  
Mix or Match.



### BULB CAPS



10/\$5!  
Mix or Match.

Item #	Description	Price
03-8063-1	Blue Bulb Cap	\$0.60
03-8063-2	Green Bulb Cap	.60
03-8063-4	Red Bulb Cap	.60
03-8063-5	White Bulb Cap	.60
03-8063-6	Yellow Bulb Cap	.60

## PLASMA DISPLAYS

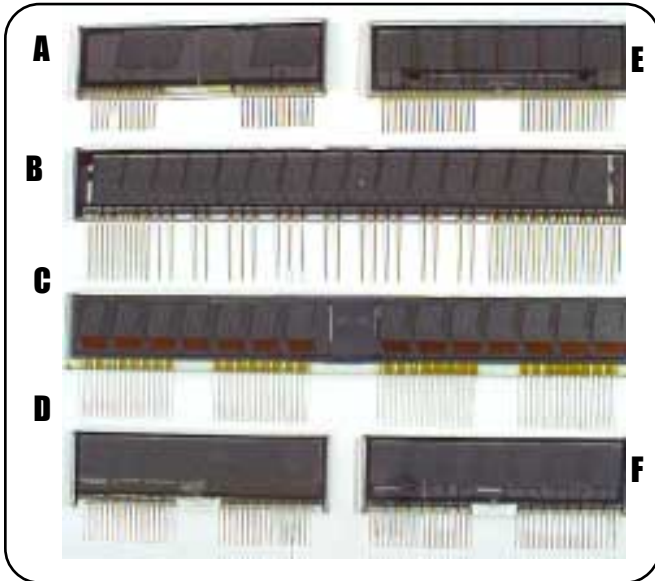

We have limited quantities of Gottlieb fluorescent displays in stock! Call for availability.

Item #	Description	Price
A <b>DIS4</b>	4-digit (WMS Match/Credit display)	<b>\$25.75</b>
B <b>DIS16</b>	16-digit alphanumeric glass	<b>45.00</b>
C <b>DIS14</b>	14-digit numeric glass	<b>45.00</b>
C <b>DIS14A</b>	14-character alpha-numeric glass	<b>45.00</b>
D <b>DIS7</b>	7-digit numeric glass	<b>25.95</b>
E <b>DIS6</b>	6-digit numeric glass	<b>25.95</b>
F <b>DIS7A</b>	7-character alphanumeric glass	<b>38.95</b>
G <b>DMM32</b>	128x32 dot matrix display MODULE (FREE shipping!)	<b>159.95</b>
- <b>DMM64</b>	192x64 Sega dot matrix display MODULE (FREE shipping!)	<b>299.95</b>

Shown Actual Size

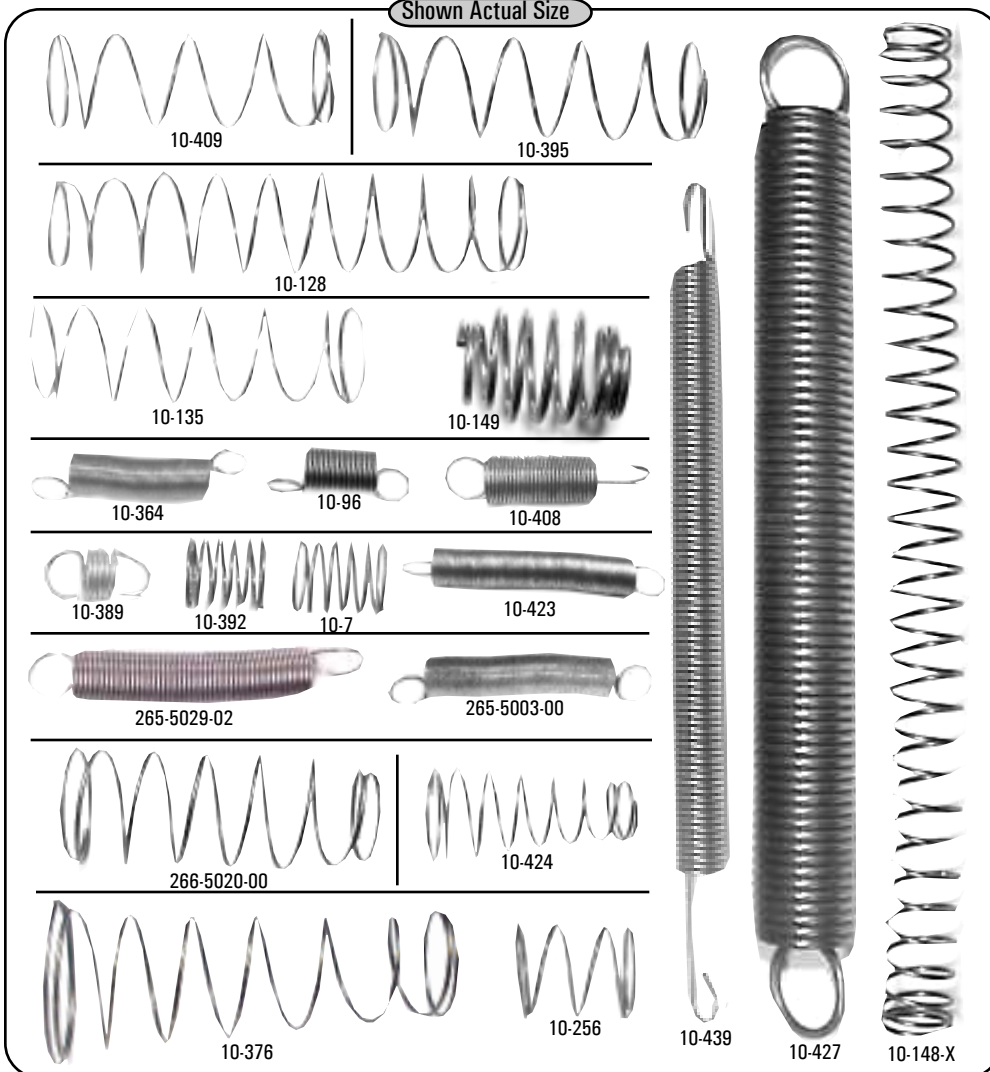

## SPRINGS

Item #	Description	Price
<b>10-7</b>	Pop bumper switch	<b>.75</b>
<b>10-96</b>	Extension spring	<b>1.50</b>
<b>10-128</b>	Compression spring	<b>.75</b>
<b>10-135</b>	Pop bumper spring	<b>.75</b>
<b>10-148-2</b>	Shooter, red, .042" - Highest tension	<b>.95</b>
<b>10-148-3</b>	Shooter, blue, .038" - High	<b>.95</b>
<b>10-148-1</b>	Shooter, silver, .035" - Med-high tension (Universal)	<b>.95</b>
<b>10-148-4</b>	Shooter, green, .033" - Med. tension	<b>.95</b>
<b>10-148</b>	Shooter, black, .031" - Low	<b>.95</b>
<b>10-148-7</b>	Shooter, white, .028" - Med-low Tension	<b>.95</b>
<b>10-148-6</b>	Shooter, brown, .026" - Lowest Tension	<b>.95</b>
<b>10-149</b>	Ball shooter outer spring	<b>.75</b>
<b>10-257</b>	Compression spring	<b>.75</b>
<b>10-364</b>	Extension spring	<b>.75</b>
<b>10-376</b>	Flipper return spring	<b>.75</b>
<b>10-389</b>	Solenoid plunger spring	<b>.75</b>
<b>10-392</b>	Compression spring	<b>.75</b>
<b>10-395</b>	Compression	<b>1.00</b>
<b>10-408</b>	Extension spring	<b>.75</b>
<b>10-409</b>	Flipper Return Spring	<b>.75</b>
<b>10-423</b>	Extension	<b>.75</b>
<b>10-424</b>	Compression	<b>1.00</b>
<b>10-427</b>	Extension spring	<b>1.50</b>
<b>10-439</b>	Extension spring	<b>1.50</b>
<b>27-1039</b>	Compression	<b>.75</b>
<b>27-10-404</b>	Compression	<b>.75</b>
<b>265-5003-00</b>	Extension	<b>.75</b>
<b>266-5020-00</b>	Compression	<b>.75</b>
<b>265-5029-02</b>	Extension spring	<b>.75</b>





# Pinballs

Put the finishing touch on your restoration and do your game a real favor with a **NEW** ball. Using an old one with tiny scratches in it is like rubbing sandpaper on your playfield!

Item #	Size	Description	Price/1	Price/3
PB118	1-1/8"	Bingo Ball	\$2.50	6.00
PB116	1-1/16"	Standard Pinball	2.00	5.00
PB1	1"	Game-specific	2.00	-
PB1516	15/16"	Roll-tilt ball	2.00	-
PB78	7/8"	Roll-tilt	2.00	-
PB58	5/8"	Baseball machine ball	2.00	-



## PINBALL POLISHES & CLEANERS



**A) Wildcat No. 125 Polish:** This classic cleaner/polish is recommended by Bally for use on any playfield to remove stubborn dirt and grime. 16oz.  
**B) Wildcat TR-60:** Great for getting off stubborn adhesives, including residue left behind by Mylar shields. 16 oz. bottle.  
**C) Wildcat RC-88:** Works well for cleaning and restoring rubber parts. 16. oz. bottle.

Fig Item #	Description	Price
A <b>W125</b>	Wildcat #125 Playfield cleaner, 16oz.	\$7.95
B <b>TR60</b>	Wildcat TR-60 Tape remover, 16oz.	7.95
C <b>RC88</b>	Wildcat RC-88 Rubber cleaner, 16oz.	7.95

# Restoration Supplies

## NOVUS PLASTIC POLISH

**A) NOVUS Plastic Polish #1:**  
 8 oz. bottle. Novus #1 is specially formulated to gently clean all plastics without scratching. It leaves a lustrous shine that repels dust, eliminates static, and resists fogging. It also helps protect against smudging and scratching.

**B) NOVUS Plastic Polish #2:**  
 8 oz. bottle. Pinball techs consider this a shop staple. Has outstanding ability to clean and shine as well as remove fine scratches, haziness, and abrasion from most plastic surfaces. It is also an excellent one-step playfield polish and cleaner. Recommended by major machine manufacturers!

**C) Novus Plastic Polish #3**  
 8 oz. bottle. For heavy scratch removal on acrylic surfaces, Novus has formulated this excellent compound designed to be used with Novus #2 or #1 as a finishing application.



Fig Item #	Description	Price
A <b>NOVUS1-8</b>	Novus 8 oz. plastic cleaner #1	\$3.89
B <b>NOVUS2-8</b>	Novus 8 oz. fine scratch remover/playfield polish #2	4.95
C <b>NOVUS3-8</b>	Novus 8 oz. heavy scratch remover #3	5.45

## KRYLON SPRAYS & PAINTS



**A) Krylon Triple Thick Crystal Clear Acrylic Spray:** This Triple Thick spray goes down 3 times thicker than competitive sprays. We recommend a gentle, spray coating of KRYLON to stop artwork deterioration on backglass. It can soften and re-adhere flaking paint in many instances.

**B-E) Krylon Webbing Spray:** These webbing sprays come in four colors: Black, White, Gold, and Silver. They're a favorite for cabinet restoration, especially on old EM's.

Fig Item #	Description	Price
A <b>KCA</b>	Krylon clear spray	\$5.95
B <b>SPWB</b>	Webbing spray, Black	4.95
C <b>SPWW</b>	Webbing spray, White	4.95
D <b>SPWG</b>	Webbing spray, Gold	4.95
E <b>SPWS</b>	Webbing spray, Silver	4.95

## NEVR-DULL POLISH

The choice of professionals for cleaning, polishing, rust and corrosion removal from all metals including silver, gold, brass, chrome, steel, aluminum. The 5 oz. can is packed with the famous "MAGIC WADDING POLISH" and works wonders on playfield and cabinet parts, electrical contacts.



**#NRD - Nev-Dull Polish.....\$4.95**

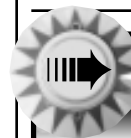

### PinTip: Safety glass

For safety's sake, use only **tempered glass** to replace your playfield glass. It resists ball impacts up to 10 times better than plate glass and won't break into dangerous shards when cracked. You can get it from your local glass store. A standard playfield glass is 21" x 43" x 1/4".

## LANE GUIDES

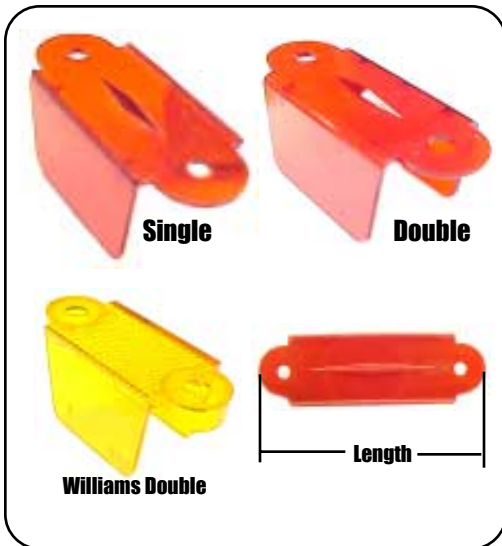

Item #	Color	Style	Length	Price
PG13	Yellow, Opaque	Single	2 1/8"	\$1.50
PG18	White	Single	2 1/8"	1.50
PG21	Red, Opaque	Single	2 3/4"	1.50
PG22	Red, Trans.	Single	2 3/4"	1.50
PG23	Yellow, Opaque	Single	2 3/4"	1.50
PG26	Blue, Trans.	Single	2 3/4"	1.50
PG28	White	Single	2 3/4"	1.50
PG31	Red, Opaque	Single	3 1/8"	1.50
PG32	Red, Trans.	Single	3 1/8"	1.50
PG33	Yellow, Opaque	Single	3 1/8"	1.50
PG39	Clear	Single	3 1/8"	1.50
PG41	Red, Opaque	Double	2 1/8"	1.50
PG48	White	Double	2 1/8"	1.50
PG51	Red, Opaque	Double	2 3/4"	1.50
PG52	Red, Trans.	Double	2 3/4"	1.50
PG53	Yellow, Opaque	Double	2 3/4"	1.50
PG56	Blue, Trans.	Double	2 3/4"	1.50
PG58	White	Double	2 3/4"	1.50
PG61	Red, Opaque	Double	3 1/8"	1.50
PG63	Yellow, Opaque	Double	3 1/8"	1.50
PG68	White	Double	3 1/8"	1.50
03-8318-9	Red, Trans.	WMS Dble	1 3/4"	1.50
03-8318-12	Orange, Trans.	WMS Dble	1 3/4"	1.50
03-8318-16	Yellow, Trans.	WMS Dble	1 3/4"	1.50

## PLASTIC POSTS

Shown Actual Size



Fig. Part #	Color	Post Style	Height	Price
A 03-8247-7	Black	Double Star	1 1/16"	\$.80
A 03-8247-8	Trans. Amber	Double Star	1 1/16"	.80
A 03-8247-9	Trans. Red	Double Star	1 1/16"	.80
A 03-8247-10	Trans. Blue	Double Star	1 1/16"	.80
A 03-8247-12	Trans. Orange	Double Star	1 1/16"	.80
A 03-8247-13	Clear	Double Star	1 1/16"	.80
A 03-8247-18	Trans. Violet	Double Star	1 1/16"	.80
A 03-8247-25	Trans. Teal	Double Star	1 1/16"	.80
A 03-8247-30	Trans. Lt. Blue	Double Star	1 1/16"	.80
B 03-8130-9	Trans. Red	Tall Dble. Star	1 1/2"	.80
B 03-8130-13	Clear	Tall Dble. Star	1 1/2"	.80
C 03-8319-8	Trans. Amber	Star	1 1/16"	.80
C 03-8319-9	Trans. Red	Star	1 1/16"	.80
C 03-8319-10	Trans. Blue	Star	1 1/16"	.80
C 03-8319-12	Trans. Orange	Star	1 1/16"	.80
C 03-8319-13	Clear	Star	1 1/16"	.80
C 03-8319-16	Trans. Yellow	Star	1 1/16"	.80
C 03-8319-18	Trans. Violet	Star	1 1/16"	.80
C 03-8319-25	Trans. Teal	Star	1 1/16"	.80
C 03-8319-30	Trans. Lt. Blue	Star	1 1/16"	.80
D 03-8370-7	Opq. Black	Star	1 1/4"	.80
D 03-8370-10	Trans. Blue	Star	1 1/4"	.80
E 03-8365-8	Trans. Amber	Narrow	1 1/4"	.80
E 03-8365-9	Trans. Red	Narrow	1 1/4"	.80
E 03-8365-10	Trans. Blue	Narrow	1 1/4"	.80
E 03-8365-13	Clear	Narrow	1 1/4"	.80
E 03-8365-16	Trans. Yellow	Narrow	1 1/4"	.80
E 03-8365-18	Trans. Violet	Narrow	1 1/4"	.80
E 03-8365-30	Trans. Lt. Blue	Narrow	1 1/4"	.80
F 03-8044-9	Trans. Red	Mini Plastic Post	1"	.80
F 03-8044-13	Trans. Clear	Mini Plastic Post	1"	.80
G 3A-7240	Opaque Red	Smooth	1"	.80
J C-11561	Opaque White	Facet	1"	.80
K C-11562	Opaque White	Facet	1 1/4"	.80



G



J



K

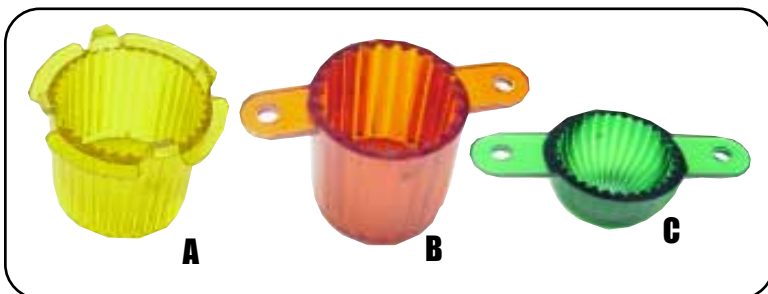

## PLASTIC LIGHT DOMES

These translucent light domes, which normally house flasher bulbs are available in: Red, Amber, Yellow, Violet, Green, Orange, Blue, and clear.

Fig/Item #	Description	Price
A 03-8171-XX	Twist lock dome, specify color	\$2.00
B 03-8149-XX	Tab dome, specify color	2.00
C 03-8662-XX	Tab mini-dome, specify color	2.00

## MINI BAYONET SOCKETS

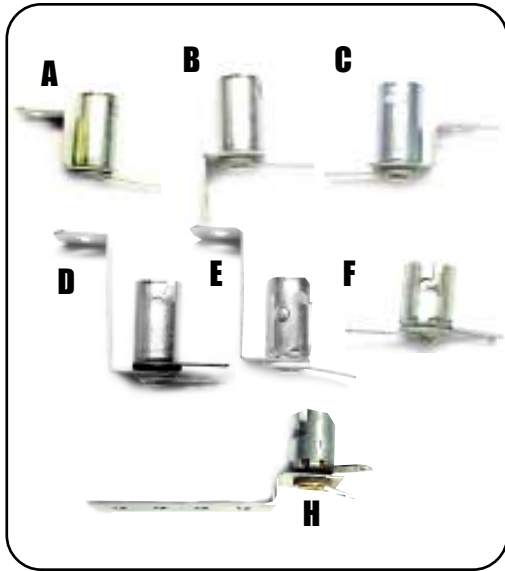

Fig Item #	Price	Price/10
A E-120-81	\$0.89	\$7.00
B E-120-99	0.89	7.00
C E-120-84	0.89	7.00
D E-120-162	0.89	7.00
E E-120-127	0.89	7.00
F E-120-176	0.89	7.00
H LSU	0.89	7.00

## MED. BAYONET SOCKETS



Fig Item #	Price	Price/10
J 077-5102-00	\$1.50	\$12.00
K 077-5100-00	1.50	12.00
L 077-5107-00	1.50	12.00
M 077-5101-00	1.50	12.00
N A-15856	1.50	12.00
P 077-5103-00	1.50	12.00

## METAL POSTS



Fig Item #	Post Type	Price
A 02-3905	Mini-post, wood screw	\$2.50
B 02-4177	Mini-post 8-32 thread	2.50
B 02-4195	Mini-post 6-32 thread	2.50
C 02-4003	Mini-post, 8-32 thread	2.50
C 02-4660	Mini-post, 10-32 thread	2.50
E 02-9899	6-32 x 2" machine thread stud	.75
F 02-3648	6-32 x 1-29/32" post stud	.75
G 02-4436-17	WMS post	1.25
H 02-4611-1	WMS post	1.25
J 02-4658	WMS post 10-32 thread	1.00
K 02-4423	WMS post 8-32 thread	1.00
L 02-4679	WMS post	1.00
M 02-4765-11	WMS post	1.00
N 02-4974-1	WMS post	1.00
O 02-5079-5	WMS post	1.00
P 02-4436-7	WMS post	1.00

## SCREWS



Fig Item #	Thread	Head	Usage	Price
M 05934	8-32	Phillips	circuit board	\$0.15
N 69084	1/4-28	Hex	set screw	.15
O 21980	10-32	Hex	coil bracket	.20
P 06564	10-32	Hex	coil bracket w/ nylock	.25
R 08520	6-32	Phillips	lock washer	.20

## WEDGE SOCKETS



Fig Item #	Price	Price/10
Q 24-8776	\$0.89	\$7.00
R 24-8767	0.89	7.00
S 24-8812	0.89	7.00
T 24-8818	1.00	9.00
U 077-5026-00	1.50	12.00
W 077-5029-00	1.50	12.00
X 077-5206-00	1.50	12.00
Y 077-5207-00	1.50	12.00
Z 077-5016-00	1.50	12.00

## T-NUTS

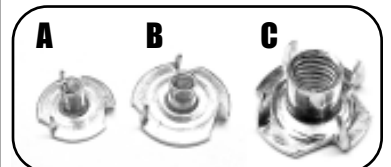

Fig Item #	Thread	Price
A TNUT632	6-32	0.25
B TNUT832	8-32	0.25
C TNUT3816	3/8-16	0.75

### PinTip: Reamed Holes

Tooth picks & wood glue are a good fix for playfield post holes that have been reamed out. For permanent repair of a worn post hole, drill the hole all the way through and install a machine thread stud and T-nut.



# Flipper Parts



## Bally EARLY STYLE

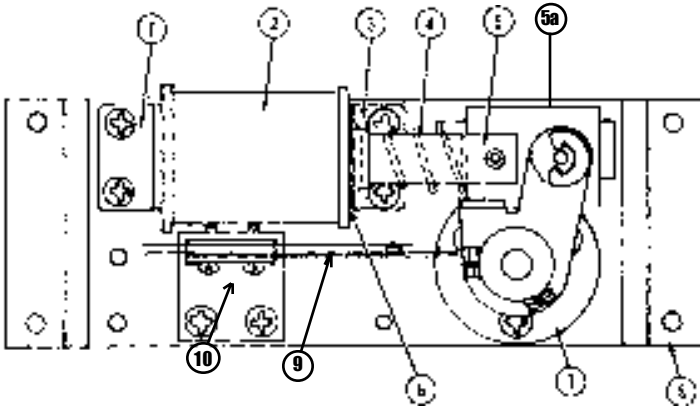

Fig Item #	Description	Price
1 <b>A-613-67</b>	Coil Stop	<b>\$3.00</b>
2 <b>Specify Coil #</b>	Flipper Coil	<b>10.95</b>
3 <b>P-108-53</b>	Coil Bracket	<b>CALL</b>
4 <b>SP-200-185</b>	Return spring	<b>.75</b>
5 <b>A-3714-1</b>	Plunger/link assy.	<b>6.00</b>
5a <b>0370-112</b>	Link Only	<b>CALL</b>
6 <b>P-1158-6</b>	Spring washer	<b>1.50</b>
7 <b>C-649-53</b>	Shaft bushing	<b>1.50</b>
8 <b>P-6264-134</b>	Mounting plate	<b>CALL</b>
9 <b>ASW-A20-23</b>	End of Stroke Switch	<b>4.50</b>
10 <b>P-126-718</b>	EOS Switch Bracket	<b>CALL</b>

## Bally LATE STYLE

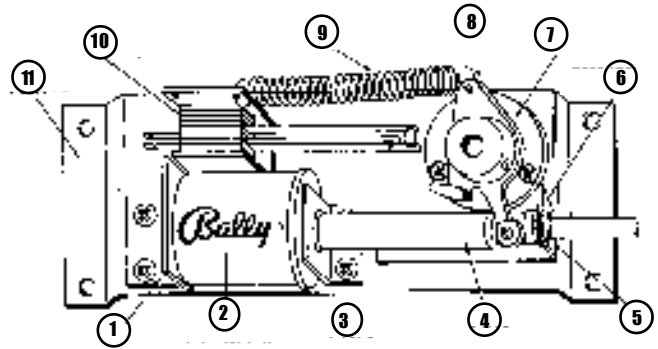

Fig Item #	Description	Price
1 <b>A-613-115</b>	Coil stop	<b>\$3.00</b>
2 <b>SPECIFY COIL NUM</b>	Coil	<b>10.95</b>
3 <b>P-108-52</b>	Coil bracket	<b>CALL</b>
4 <b>S-496-217</b>	Plunger	<b>CALL</b>
5 <b>C-537-8</b>	Plunger nyloner	<b>.75</b>
6 <b>P-6685-636</b>	Stop bracket	<b>CALL</b>
7 <b>C-649-53</b>	Shaft bushing	<b>CALL</b>
8 <b>A-3711-4</b>	Crank (specify left or right)	<b>9.00</b>
9 <b>SP-110-363</b>	Flipper return spring	<b>.75</b>
10 <b>ASE-982-1295</b>	End-of-stroke switch	<b>4.00</b>
11 <b>P-6264-134</b>	Assy. mounting plate	<b>CALL</b>

## Williams EARLY STYLE

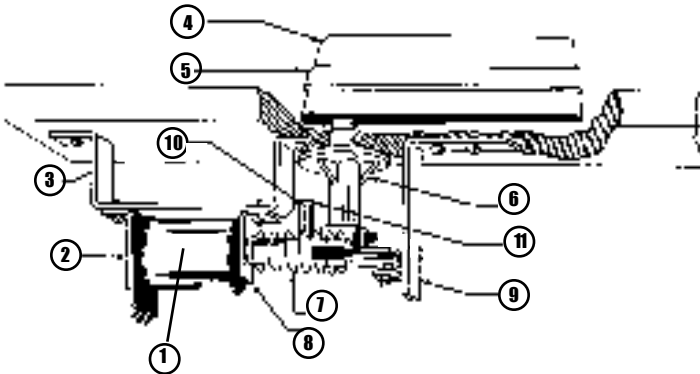

Fig Item #	Description	Price
1 <b>Specify Coil #</b>	Coil	<b>\$10.95</b>
2 <b>A-8143</b>	Coil stop	<b>CALL</b>
3 <b>01-600</b>	Coil mounting bracket	<b>CALL</b>
4 <b>03-7253</b>	Plastic bat	<b>2.00</b>
5 <b>38-6519-4</b>	Rubber ring	<b>1.05</b>
6 <b>03-6014</b>	Shaft bushing	<b>CALL</b>
7 <b>10-135</b>	Return spring	<b>.75</b>
8 <b>01-8-508-3</b>	Coil mounting plate	<b>CALL</b>
9 <b>01-3203</b>	Plunger stop bracket	<b>CALL</b>
10 <b>03-7811A</b>	End-of-Stroke switch	<b>4.00</b>
11 <b>A-4962L (or R)</b>	Flipper cam	<b>5.00</b>

## Williams LATE STYLE

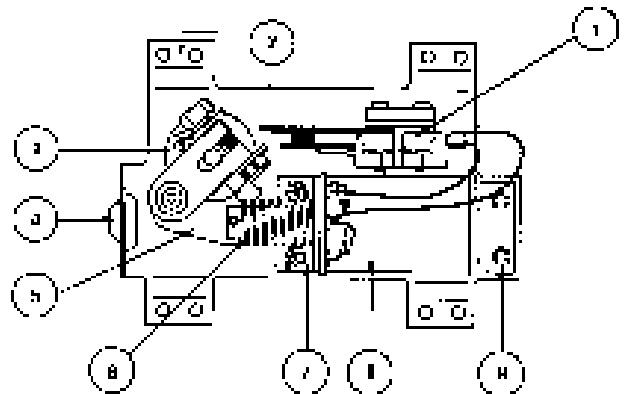
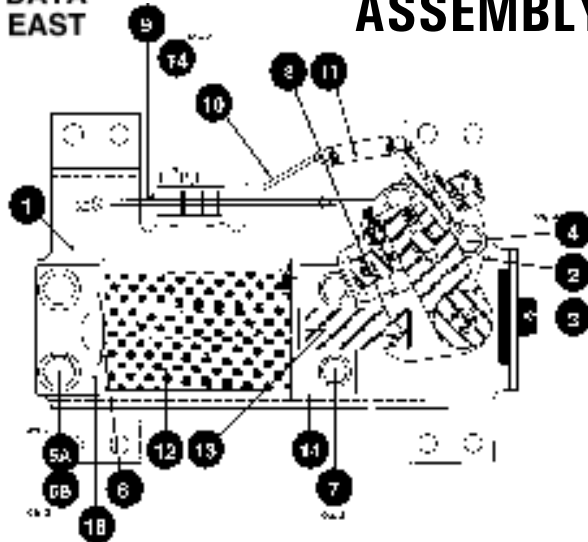

Fig Part #	Description	Price
1 <b>SWIA194</b>	End of Stroke switch	<b>\$4.50</b>
2 <b>B-13104-R</b>	Flipper mounting plate	<b>10.95</b>
3 <b>03-7568</b>	Flipper shaft bushing	<b>1.50</b>
4 <b>38-6577</b>	Bumper Plug	<b>.50</b>
5 <b>B-10655 R (or L)</b>	Crank Link Assembly	<b>9.95</b>
5a <b>B-13884-R (or L)</b>	Flipper Crank Assembly	<b>3.00</b>
5b <b>A-10656</b>	Flipper Link Assembly	<b>3.00</b>
6 <b>10-376</b>	Flipper return spring	<b>.75</b>
7 <b>01-7695</b>	Coil Bracket	<b>2.00</b>
8 <b>Coil #</b>	Coil	<b>10.95</b>
9 <b>A-12111</b>	Coil stop	<b>3.00</b>



## FLIPPER ASSEMBLY



FigPart #	Description	Price
1	515-6617-00 Flipper Base Plate - Right	\$9.95
	515-6617-01 Flipper Base Plate - Left	9.95
2	545-5594-00 Flipper Bushing	1.95
3	545-5428-00 Bumper	.75
4	#6-32 x .38" Screw	.25
5a	#10-32 x .38" Screw	.25
5b	#10 Lock Washer	.25
6	Spring Washer	.25
7	#8-32 x .38 Screw	.25
8	515-6518-00 Plunger, Link & Pawl Sub-Assy (R)	9.95
	515-6518-01 Plunger, Link & Pawl Sub-Assy (L)	9.95
9	180-5149-00 End-of-stroke Switch	2.95
10	535-7354-01 Switch Plate	.35
11	265-5035-00 Flipper Return Spring	.45
12	Specify Coil #	10.95
13	545-5388-00 Coil Sleeve	.65
14	535-7356-00 Coil Support Bracket	.60
16	515-6308-01 Coil Stop	3.25

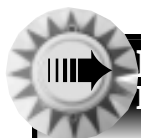

### PinTip: Blade Wipers

Adjust leaf blade switches so that they have a 'wiping' action when they close and open. This technique extends contact point life with a self-cleaning action. Use switch adjusting tools for more precise adjustment.



### PinTip: Cheap Flip Fix

For a cheap way to add zip back to your solenoids, replace the coil sleeves (Page 24). Dirty sleeves are the most common cause for sluggish coils.

## FLIPPER REBUILD KITS

#WFLTRON



A

#WFLKIT



B

#SEGAFKIT



C

These all-new flipper parts kits are the answer for sticky sluggish, weak flippers. #WFLTRON is for newer WMS/Bally machines with Fliptronic® flippers. #WFLKIT repairs earlier (Pre-1991) Williams machines (note the presence of the spark-suppressing capacitor). #SEGAFKIT is for Sega, Data East and post-2000 Stern machines.

FigPart #	Description	Price
A	WFLTRON WMS Fliptronic Flipper Rebuild Kit	\$29.95
B	WFLKIT WMS Old style flipper rebuild kit	29.95
C	SEGAFKIT SEGA/Stern/D.E. flipper rebuild kit	29.95

# Pop Bumper Parts

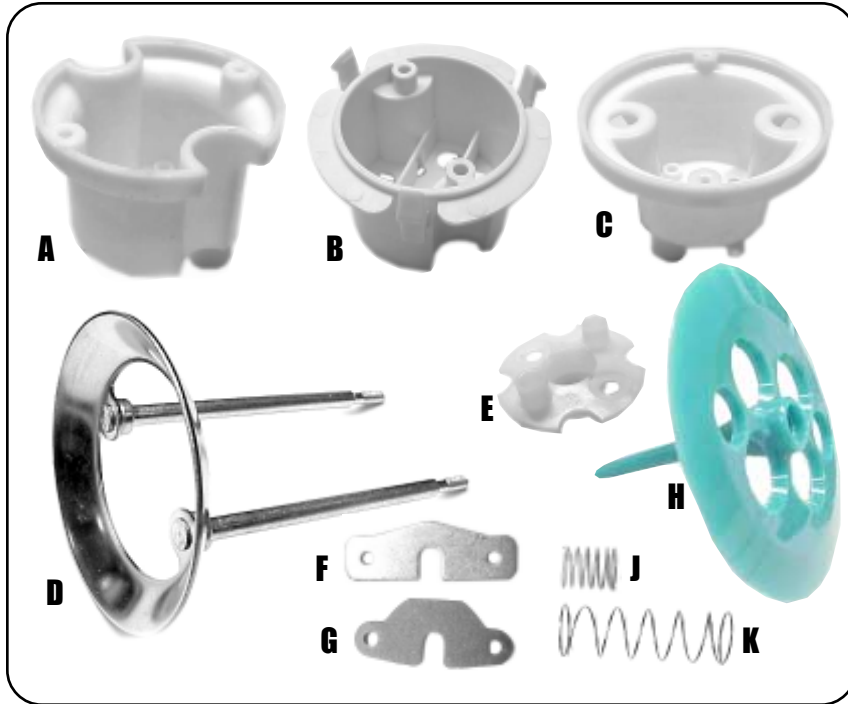

## POP BUMPER PARTS

Fig. Part #	Description	Price
A 03-7443-5	WMS Pop Bumper Body	2.50
B C-470-5	Bly Pop Bumper Snap-on cap style	3.00
C C-114-3	Bly Pop Bumper Body	\$2.00
D A-4754	Ring & Rod Assy (60-1705)	4.00
E C-115-1	Bumper Base (WMS #03-6009-A5)	2.00
F 01-5492	Metal Yoke (Part #A5492)	1.00
G 01-5493	Fiber Yoke (Part #A5493)	1.00
H 03-6035-1	Blue Bumper Skirt	2.00 3/\$5
H 03-6035-3	Violet Bumper Skirt	2.00 3/\$5
H 03-6035-4	Red Bumper Skirt	2.00 3/\$5
H 03-6035-5	White Bumper Skirt	2.00 3/\$5
H 03-6035-6	Yellow Bumper Skirt	2.00 3/\$5
H 03-6035-7	Black Bumper Skirt	2.00 3/\$5
H 03-6035-15	Orange-Red Bumper Skirt	2.00 3/\$5
H 03-6035-G	Green Bumper Skirt	2.00 3/\$5
H 03-6035-T	Teal Bumper Skirt	2.00 3/\$5
J 10-7	Skirt Spring (GTB #A-10430)	.75
K 10-135	Pop Bumper Spring	.75

## BUMPER CAPS



Fig Part #	Color	Cap Style	Price
A GPBC-10	Trans. Blue	Grooved	\$4.00
A GPBC-9	Trans. Red	Grooved	4.00
A GPBC-16	Trans. Yellow	Grooved	4.00
B 03-9007-12	Trans. Orange	Starburst	4.00
C 03-8254-8	Trans. Amber	Plain	4.00
C 03-8254-9	Trans. Red	Plain	4.00
C 03-8254-10	Trans. Blue	Plain	4.00
C 03-8254-12	Trans. Orange	Plain	4.00
C 03-8254-13	Clear	Plain	4.00
C 03-8254-16	Trans. Yellow	Plain	4.00
C 03-8254-18	Trans. Violet	Plain	4.00
C 03-8254-25	Trans. Teal	Plain	4.00
C 03-8254-28	Tr. Org-Gold	Plain	4.00
D 545-5199-02	Tr Red	Sega	4.00
- 03-8291-16	Tr Yellow	Wide Edge	4.00
- 03-7444-16	Opaque Yellow		4.00
- 03-7444-9	Opaque Red		4.00
- 03-7444-W	Opaque White		4.00

## FLIPPERS & BATS

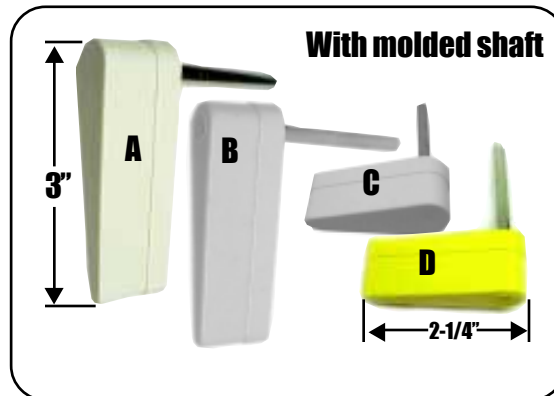
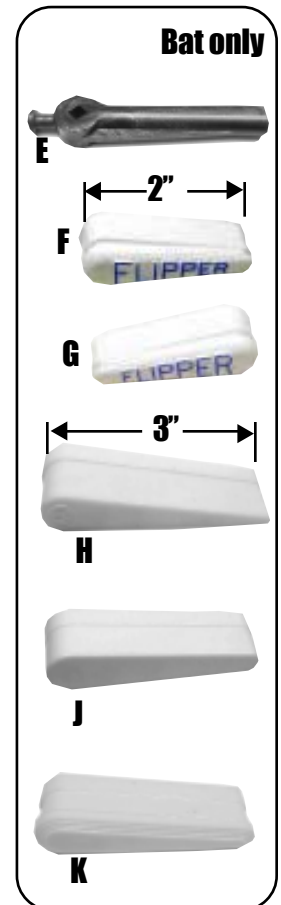

Fig Part #	Description	Price
A 545-5133-01	Sega/Stern/D.E Flipper+ shaft white	3.00
B 20-10110-15	WMS/BLY Flipper+ Shaft Orange	\$3.00
B 20-10110-7	WMS/BLY Flipper+ Shaft Black	3.00
B 20-10110-5	WMS/BLY Flipper+ Shaft White	3.00
B 20-9250-5	WMS/BLY Flipper+ Shaft Off-White	3.00
B 20-10110-6	WMS Flipper+ Shaft Yellow	3.00
- 20-9734-5	WMS Flipper+ Shaft Lightning Bolt	4.00
C 20-9132-5	WMS 2" Flipper+ shaft	3.00
D 20-10290-6	WMS 2.25" Flipper+ Shaft Yellow	3.50
E 03-8516	WMS Slugfest baseball bat	6.00
F C-609-5	BLY 'Flipper' 2" flipper bat L	5.00
G C-610-5	BLY 'Flipper' 2" flipper bat R	5.00
H 03-7253	WMS Flipper Bat	2.50
J C-611-5	BLY Flipper Bat	2.50
K C-13150	GTB Flipper Bat	2.50
- A3994-8	Black Flipper+ Shaft	3.00
- A3994-8GR	Trans. Green Flipper+ Shaft	3.00







# Coils and Sleeves

## COILS

There are hundreds of varieties of coils used in pinball machines. We carry nearly all of them. If we don't have the coil you need, we can get it. All coils come with new sleeves where applicable. Below are some of the more common coils used in machines that we have in stock:

Coil	Type	Coil	Type	Coil	Type
A-1496	Single	AQ25-500/34-4500	Dual	B126-800	Single
A-4893	Single	AQ25-500/34-5050	Dual	SFL23-600/30-2600	Dual
A-5141	Single	AN26-1200	Single	FL20-300/28-400	Dual
A-5143	Single	G32-2500	Single	SA/SG23-850	Single
A-5194	Single	B26-1100	Single	SA23-900	Single
A-5195	Single			FL21-375/28-400	Dual
A-9742	Relay	<b>Williams</b>		Z28-1150/1200/1250	Dual
A-9746	Relay	A22-550	Single	FL11629	Dual
A-19300	Single	SA23-750DC	Single	FL11630	Dual
A-16570	Single	SG23-750	Single	FL11722	Dual
A-18102	Single	AE23-800-XX	Single	FL11753	Dual
A-25959	Single	A-226-1025	Single	FL15411	Dual
		SFL-20-300/30-00	Dual		

#COILNUMBER - Single-Wound Coil(Specify Coil # as Part #) ..... **\$6.95**  
 #COILNUMBER - Dual-Wound Coil(Specify Coil # as Part #) ..... **\$10.95**



**Great Coil Prices!**

Single Wound coils & Relays

**\$6.95**

Dual-Wound Flipper Coils:

**\$10.95**

## ARMATURES

Shown Actual Size

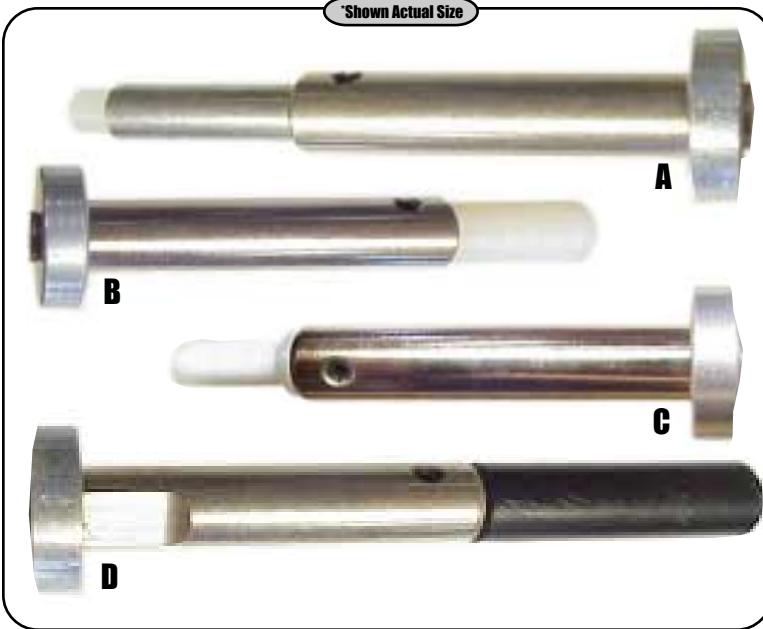
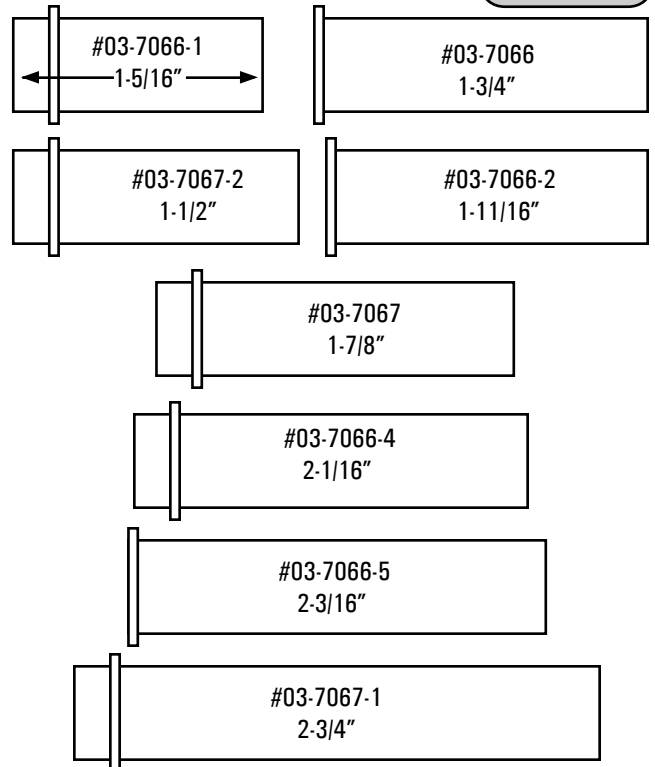

Fig Item #	Description	Price
- 04-10019	Armature Assy	<b>\$12.00</b>
- 04-10291	Armature & Extension Assy.	<b>11.00</b>
A <b>A-6306-2</b>	Kickback Plunger Armature	<b>7.00</b>
- <b>A-11139</b>	Armature Assy.	<b>12.00</b>
- <b>A-11336</b>	WMS Armature Assy.	<b>10.00</b>
- <b>A-11516</b>	Armature Assy.	<b>6.00</b>
B <b>A-15370</b>	Plunger Assy. (Addams Family)	<b>6.00</b>
C <b>A-15371</b>	WMS Armature	<b>5.00</b>
- <b>A-15580</b>	Ball Popper Armature Assy.	<b>9.00</b>
D <b>A-17767</b>	Pop-up Armature	<b>6.00</b>
- <b>A-17768</b>	Armature & Extension assy.	<b>6.00</b>
- <b>A-17986</b>	Bell Armature Assy.	<b>11.00</b>
- <b>A-19640</b>	Armature & Extension assy.	<b>6.00</b>

## COIL SLEEVES

Shown Actual Size



Item #	Length	Price
<b>03-7066-1</b>	1-5/16"	<b>\$0.75</b>
<b>03-7067-2</b>	1-1/2"	<b>.75</b>
<b>03-7066-2</b>	1-11/16"	<b>.75</b>
<b>03-7066</b>	1-3/4"	<b>.75</b>
<b>03-7067</b>	1-7/8"	<b>.75</b>
<b>03-7066-4</b>	2-1/16"	<b>.75</b>
<b>03-7066-5</b>	2-3/16"	<b>.75</b>
<b>03-7067-1</b>	2-3/4"	<b>.75</b>

# Switches



## Face Styles

Shown Actual Size

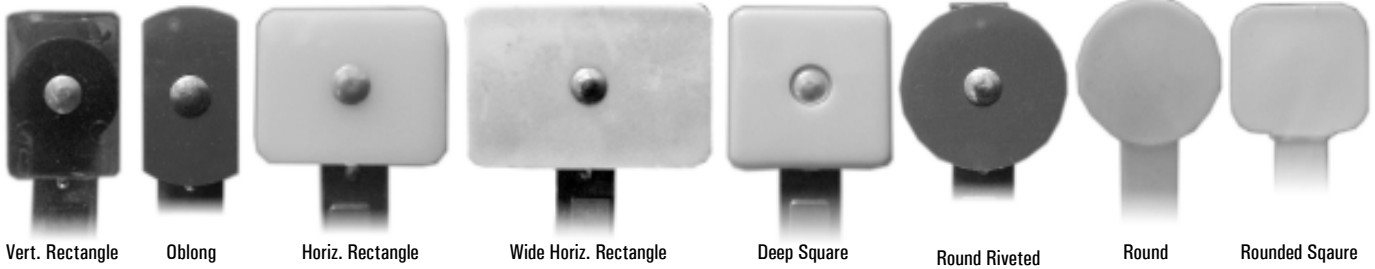

## Bracket Styles

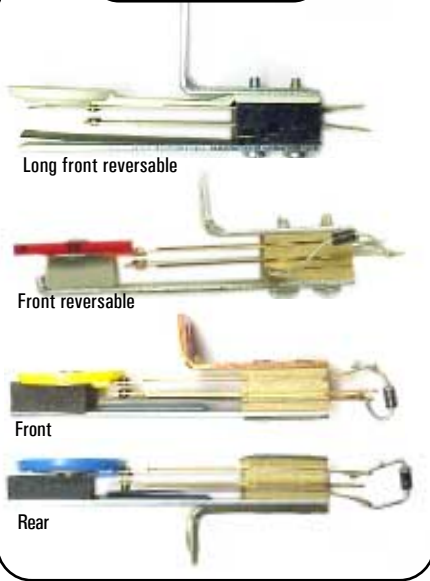

## STAND-UP TARGETS

\* Colors are Opaque unless prefixed with a "Tr." - transparent.

All targets are **\$6.00**

Item #	Face	Bracket	Color
A-9999-4	R. Rivet	Front	Tr. Red
A-9999-1	R. Rivet	Front	Tr. Blue
A-14604-11	V. Rect	Front	Tr. Green
A-14604-20	V. Rect	Front	Orange
A-14690-6	R. Rivet	Rear	Yellow
A-15658-2	Oblong	Front	Green
A-16816-4	Oblong	Rear	Red
A-17799-6	R. Rivet	Front	Yellow
A-18018-21	Deep Square	Front	Green
A-18059-15	W. H. Rect	Front	Orange
A-18530-1	Oblong	Front	Blue
A-18530-6	Oblong	Front	Yellow
A-18605-1	R. Rivet	Front	Blue
A-18605-2	R. Rivet	Front	Green
A-18605-4	R. Rivet	Front	Red
A-18605-5	R. Rivet	Front	White
A-18605-6	R. Rivet	Front	Yellow

Item #	Face	Bracket	Color
A-18605-15	R. Rivet	Front	Orange
A-20014-5	Oblong	Rear	White
A-21349-1	R. Rivet	Rear	Blue
15-4482	V. Rect	F. Rev	Tr. Red
15-4483	V. Rect	F. Reve	Tr. Blue
99-SUTCW	Round	L. Fr. Rev.	White
99-SUTSY	Round Sq.	Front Rev.	Yellow
B-14060-9	Deep Square	Front	Tr. Red
SW-1A-161-2P	Horiz. Rect.	---	White
SW-1A-174-1	Horiz. Rect.	---	Blue
SW-1A-184-19P	Deep Square	---	Yellow
SW-1A-184-21-P	Deep Square	---	Green
515-5934-02	Deep Square	---	Red
515-5934-01	Deep Square	--	Clear
500-5321-06	W. H. Rect.	Front	Yellow
515-5934-03	Deep Square	Front	Tr. Yellow

## SWITCHES

Fig Part #	Description	Price
N 12-SMSW	Wire Sub-Micro	1.95
O 12-SMSB	Blade Sub-Micro	1.95
P SW-1010-A13	WMS double flipper	6.00
R SW10A-48	WMS flipper cabinet	4.50
S 03-7811	End-of-stroke Norm Closed	4.50
T B-9951-1	WMS Lane change	4.00
U SW1A194	E.O.S., Norm Open.	4.00
V ASE9821295	E.O.S., N.C.	4.00
W 5641-12724	WMS operator switches	14.00
X 12-CP	Micro switch	3.50
Y 12-CRB	Micro roller blade	3.75
Z 12-CCS	Micro coin switch	3.50
AA V3L-507DB	Micro blade	3.50
BB C-921	Pop bumper plastic spoon	1.00
CC 14-0645	Switch wire	.35
- S647-12133-12	Ball trough micro switch	3.50
- SW-1A-119	WMS switch	2.00
- SW-1A-120	Slingshot switch	4.00
- 06-BAT-20	WMS Copper switch blade	.25

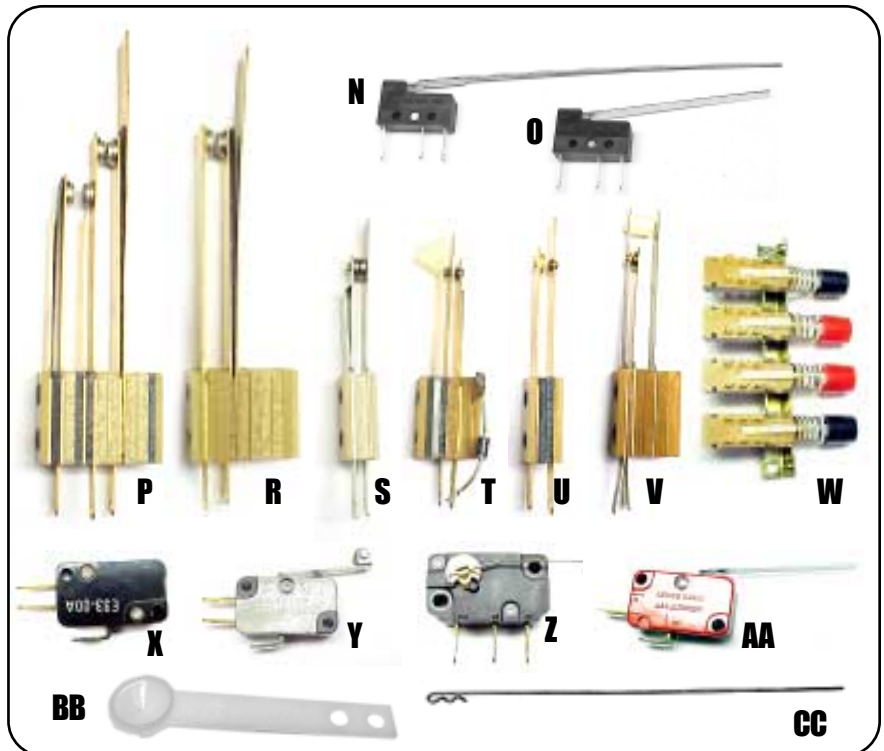

Marco Specialties Inc.

©2000 Marco Specialties, Inc. All rights reserved.

803-957-5500

www.pinballmachine.com

fax: 803-957-6974

# Cabinet Parts

## LOCKS

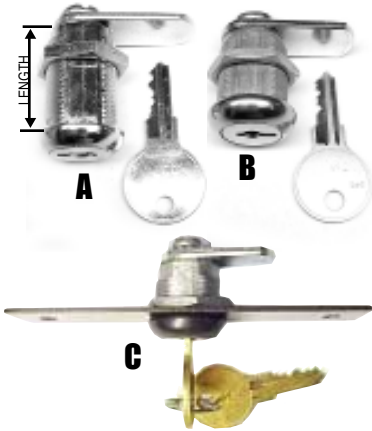

Item #	Description	Price
A) LKA118	1-1/8" keyed-alike	\$4.00
B) LKA78	7/8" keyed-alike	4.00
C) A-13379	WMS backglass lock w/ bracket	9.00

## FLIPPER BUTTONS

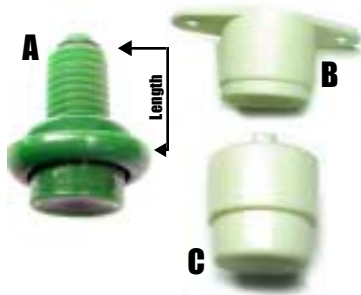

Fig Item #	Color	Len.	Price
A A-16883-4	Red	1"	\$2.00
A A-16883-DR	Dark Red	1"	2.00
A A-16883-5	White	1"	2.00
A A-16883-6	Yellow	1"	2.00
A A-16883-15	Orange	1"	2.00
A A-16883-1	Blue	1"	2.00
A FBSTO	Trans. Orange	1"	2.00
A FBSTR	Tr. Red	1"	2.00
A FBSTG	Trans. Green	1"	2.00
A FBLG	Green	1-1/2"	2.00
A FBLTB	Trans. Blue	1-1/2"	2.00
B BBH	Bally White	-	1.50
C BFB	Bally White	-	1.50

## BALL SHOOTER PARTS

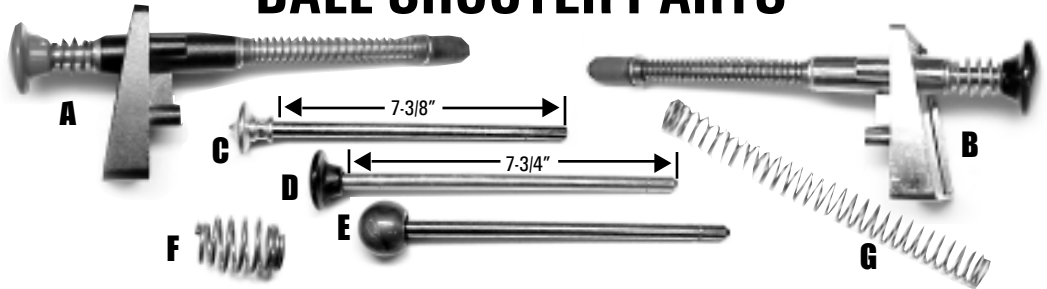

Fig Item #	Description	Price
A BSAR	Black shooter assembly, Red knob	\$17.95
B B-12445	Chrome shooter assembly	17.95
C A-100-12	Pointed end (Bally style) shooter rod	7.95
D 20-9258-7	Rounded end new-style shooter rod	6.00
E 20-9927-1	Silver-ball ended shooter rod (as used on Scared Stiff)	9.50
F 10-149	Outer shooter spring	.75
G 10-148-2	Shooter, red, .042" - Highest tension	.95
G 10-148-3	Shooter, blue, .038" - High tension	.95
G 10-148-1	Shooter, silver, .035" - Med-high tension (Universal)	.95
G 10-148-4	Shooter, green, .033" - Med. tension	.95
G 10-148	Shooter, black, .031" - Low tension	.95
G 10-148-7	Shooter, white, .028" - Med-low Tension	.95
G 10-148-6	Shooter, brown, .026" - Lowest Tension	.95
- 03-7357	WMS ball shooter sleeve	.75

## PINBALL LEGS

Item #	Color	Length	Price / ea.	Price / 4
A-19514	Chrome	28 1/2"	\$19.00	\$75.00
A-19514-2	Powder Black	28 1/2"	19.00	75.00
A-19514-4	Gold	28 1/2"	19.00	75.00
A-19514-5	Blue	28 1/2"	19.00	75.00

## CABINET HARDWARE

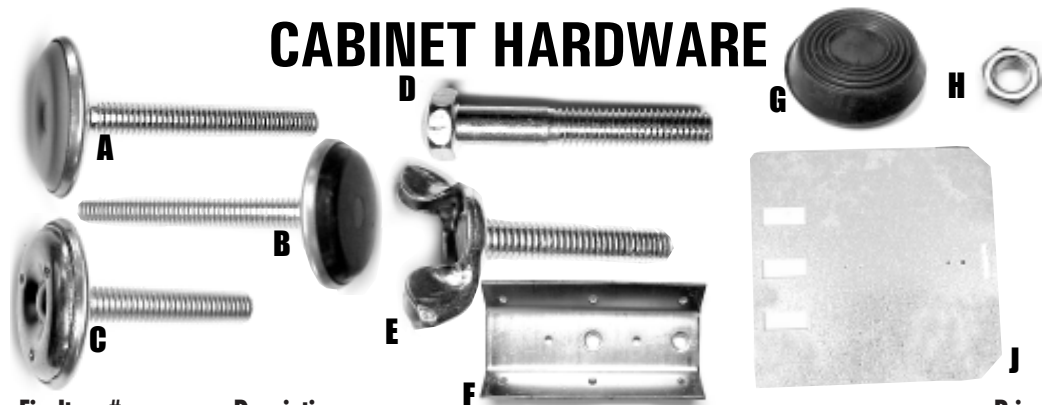

Fig Item #	Description	Price
A LL3	Leg leveler, metal, 3"	\$1.00
B LL3N	Leg leveler, nylon base, 3"	1.25
C LL2	Leg leveler, metal, 2"	1.00
D LB58	5/8" chrome acorn head leg bolt	.75
D LB58B	5/8" brass acorn head leg bolt	1.00
E WBB	Wing Bolt, for back boxes	1.00
F 01-11400-1	Williams new style leg bolt plate	3.95
G LLPRC	Leg leveler protective rubber cup	.50
H LLN	Leg leveler nut	.15
J 01-11028	Williams cashbox lid	6.95



# Decals & Drop Targets



## DROP TARGETS & OTHER DECALS

Partial selection shown; check list for more games.

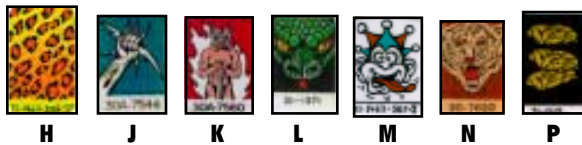

## DECALS

Fig Item #	Game	Price
A 30-7599	Algar	7.50
B 30A-7572	Alien Poker (Yellow Guy)	7.50
- 30-5009DT	Back to the Future (Flames)	5.00
EE 99-1	Bad Cats Targets	12.50
C 31-1021	Barracora	10.00
D 30-7603	Black Knight	15.00
E 31-1463-563	Black Knight 2000	7.50
- 30-7575B	Blackout	12.50
- 99-2	Big Guns	10.00
- 99-3	Checkpoint	10.00
F 31-1367	Comet (Dummy)	5.00
- 31-1040	Cosmic Gunfight	12.50
G 31-1452	Cyclone (Spooks)	5.00
Z 31-1452F	Cyclone (Ferris Wheel)	15.00
- 31-1090-3	Defender	20.00
- 99-4	Diner	7.50
H 31-1463-568	Dr. Dude	5.00
AA 31-1463-574	Earthshaker	7.50
T 31-1464-2011	Elvira (Complete)	25.00
- 99-5	Firepower (Drop Targets)	7.50
J 30A-7544	Flash	10.00
K 30A-7560	Gorgar	7.50
L 31-1371	Grand Lizard	10.00
BB 31-1380	High Speed (Spinner)	5.00
- 31-1784	Indiana Jones	5.00
M 31-1463-567	Jokerz	12.50
CC 99-22	Kiss (Spinner F&B)	5.00
N 30-7620	Jungle Lord	12.50
- 30A-7558	Lazerball	12.50
- 30-7575	Lazer Cue	7.50
P 30-1415	Millionaire	5.00
Q 31-1003	Pharaoh	15.00
R 31-1401	Pinbot	5.00
- 30A-7541-1	Phoenix	12.50
S 31-1463-576	Roller Games	\$5.00

Fig Part #	Game	Price
- 30-7580	Scorpion	12.50
X 30-5116-XX	Simpsons (Complete)	25.00
- 30-5116-P	Simpsons (6 Pins only)	12.50
T 31-1010	Solar Fire	15.00
- 30-7575S	Sorcerer	12.50
- 31-1437	Space Station	5.00
U 30A-7547	Stellar Wars	12.50
W 31-1640	Terminator 2	5.00
- 31-1401	Taxi	10.00
- 30A-7546	Time Warp	10.00
- 99-6	F/14 Tomcat (Spinner)	3.00
- 99-7	Torpedo Alley	7.50
- 30A-7543	Tri-Zone	5.00
- 30-1074	Warlock	12.50
Y 31-1463-574	Whirlwind	5.00

### ROUND STICKERS

- 99-8	Cats	7.50
- 99-9	Ducks	7.50
- 99-10	Explosion	5.00
- 99-11	Firepower	12.50
- 99-12	Firepower II	12.50
- 99-13	Rabbits	7.50
- 99-14	Road Kings	12.50
- 99-15	Space Station	15.00

### SLINGSHOT PLASTICS

- 99-16	Cyclone Slingshot Plastics	35.00
- 99-17	Terminator 2	35.00
- 99-18	Black Knight 2000	35.00
- 99-19	Whirlwind	35.00
- 99-20	Dr. Who	35.00

### COIN DOOR STICKERS & MISC

FF GOTSTKE	Early Gottlieb Coin Door Sticker	5.95
		3/\$12
GG GOTSTKL	Late Gottlieb Coin Door Sticker	5.95
		3/\$12
JJ BLYSTKS	Bally Susan B. Anthony Coin Door Sticker	5.95
		3/\$12
KK BLYSTK	Bally Coin Door Sticker	5.95
		3/\$12
HH 99-21	Whirlwind Spinning Discs	25.00

## DROP TARGETS

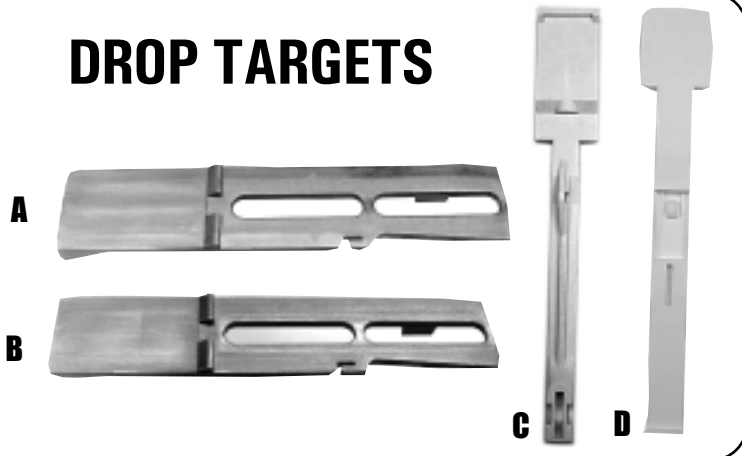
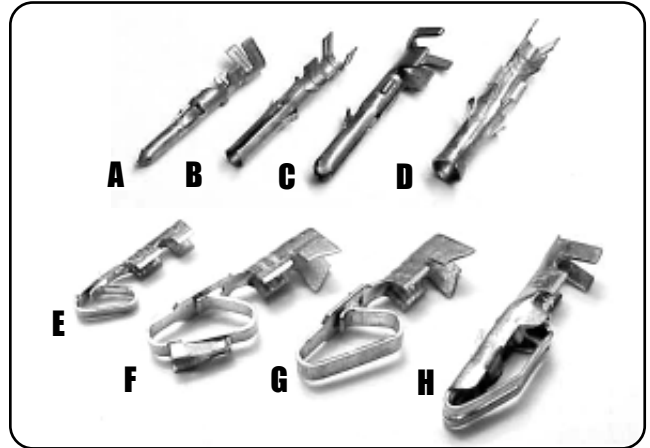

Fig Part #	Description	Price
A 03-8750	WMS Drop target	\$4.50
B 03-8749	WMS Drop target skinny back	\$4.50
C A-11905	Bally Drop Target	4.50
D 545-5048-01	Sega/Data East Drop Target	4.50

## MOLEX® CONNECTOR PINS

Crimp Terminals (connector pins) come in two sizes for most pinball machines: .156" and .100" centers. This refers to the spacing between the center of each terminal when mounted on the circuit board. Trifurcon terminals are excellent for high-current applications where overheated connectors need repair.

Fig Item #	Description	Price/30
A	CT062M .062" Male round crimp terminal	\$5.00
B	CT062F .062" Female round crimp terminal	5.00
C	CT093M .093" Male round crimp terminal	5.00
D	CT093F .093" Female round crimp terminal	5.00
E	CT100S .100" Standard crimp terminal	5.00
F	CT156T .156" Trifurcon crimp terminal	5.00
G	CT156S .156" Standard crimp terminal	5.00
H	CT156EC .156" Edge connector terminal	5.00



## HOUSINGS AND HEADERS

### HOUSINGS

Fig Item #	Spacing	No. of Positions	Price
- CF10016	.100"	16	1.20
- CF10017	.100"	17	1.25
- CF10024	.100"	24	1.80
E CF10028	.100"	28	2.00
D CF15608	.156"	8	.80
C CF15609	.156"	9	.90
B CF15610	.156"	10	1.00
- CF15611	.156"	11	1.10
A CF15620	.156"	20	\$2.00
F CFREH	.156"	8, rear-entry	1.25

### HEADERS

G CMI5605	.156"	5	\$0.50
- CMI5608	.156"	8	.80
L CMI5609	.156"	9	.95
H CMI5610	.156"	10	1.00
- CMI5611	.156"	11	1.10
K CMI5620	.156"	20	1.75
- CMI5624	.156"	24	2.40
J CM10012	.100"	12	.85
- CM10017	.100"	17	1.20
- CM10020	.100"	20	1.60
I CM10025	.100"	25	2.00

Our extractor tools on page 33 make short work of removing difficult pins!

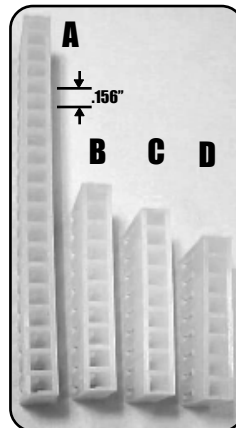

## CONNECTOR KITS

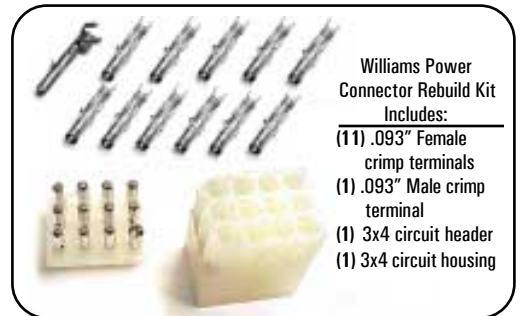

Williams Power Connector Rebuild Kit Includes:  
 (11) .093" Female crimp terminals  
 (1) .093" Male crimp terminal  
 (1) 3x4 circuit header  
 (1) 3x4 circuit housing

Data East / Williams Power Connector Rebuild Kit (Above): This connector kit repairs burnt power connects on early Williams and Data East solid state machines. It contains everything shown above.

Bally Power Connector Rebuild Kit (Not Shown): Kit contains (1) #CF15620, (1) #CF15610, (1) #CF15608, with matching header pins, as well as (40) Trifurcon® crimp terminal pins.

Item #	Description	Price
CKWMS	WMS connector rebuild kit	\$4.95
CKBLY	Bally connector rebuild kit	9.95

## POWER CORDS



Item #	Description	Price
PC10	10' AC Power cord	\$3.50
PC15	15' AC Power cord	4.50
PCIEC	8' AC Computer power cord	3.00
PCSTRIP	6-outlet power strip w/ 5' cord	5.95

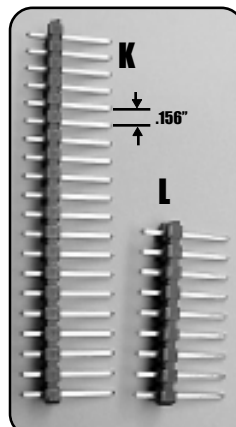
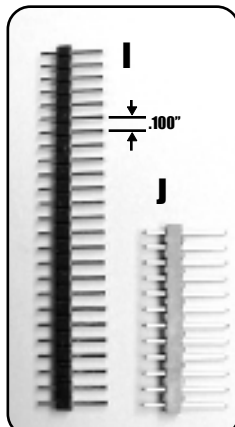
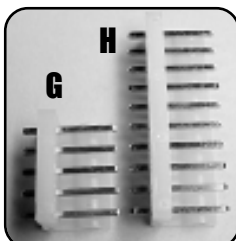
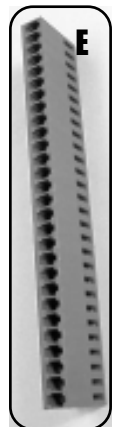

# Electronic Components



## INTEGRATED CIRCUITS



Item#	Package	Description	Price
555	DIP-6	IC - (NE555) Timer IC	\$1.50
LM339N	DIP	IC - Quad Differential Voltage Comparator	1.50
LM741D	DIP	IC - Comparator OP amp	.90
ULN2803A	DIP	IC -	4.50
MOC3011	DIP-8	Opto IC	2.95
CA3081A	DIP-14	IC-Transistor Array	3.95
3459	DIP	(MC3459) Quad Memory Driver	3.00
4011	DIP	(MC14011) Quad NAND gate IC	1.10
4042	DIP	Cmos IC	1.50
4046	DIP	Cmos IC	1.75
4049	DIP	Cmos (MC14049) Hex Inverter/Buffer	.50
4066	DIP	Cmos IC	1.25
MC14514	DIP	Cmos IC	2.50
5101	DIP-22	CMOS RAM	4.00
UDN6118A	DIP	Display driver (NE585, UDN6184, XR6118P)	4.95
6264LP-12	DIP	RAM IC	8.95
6532	DIP-40	RIOT IC (GOTTIEB) 40 pin	12.00
6800	DIP-40	CPU Microprocessor IC	4.50
6802	DIP-40	CPU Microprocessor IC	6.95
6810	DIP-24	IC - RAM	4.00
6821	DIP-40	IC - PIA (Peripheral Interface Adapter)	4.50
7400	DIP-14	IC - Quad 2-input NAND gate	.40
7402	DIP-14	IC - Quad 2-input NOR	1.00
7404	DIP-14	IC - Hex Inverter	1.00
7405	DIP-14	IC - Hex Inverter	1.00
7408	DIP-14	IC - Quad 2-input AND	.75
7410	DIP-14	IC - Triple 3-input NAND	1.75
7414	DIP-14	IC - Hex Schmitt Trigger Inverting	1.50
7430	DIP-14	IC - Single 3-input NAND	2.00
7432	DIP-14	IC - Quad 2-input OR	.75
7442	DIP-14	IC - BCD to decimal decoder	2.12
7474	DIP-14	IC - Dual D flip flop	.75
7483	DIP-14	IC - 4-bit Full Add	2.00
7486	DIP-14	IC - Quad ex-OR gate	1.00
74107	DIP-14	IC - Dual JK flip flop	.75
74138	DIP-14	IC - 1 of 8 Decoder/Dempx.	2.00
74139	DIP-14	IC - Dual 2/4 decoder	1.00
74154	DIP-14	IC - 4-16 line Decoder/Dempx.	2.95
74155	DIP-14	IC - Dual 2-Bit Bin.- 4 line strobe Decode/Dempx.	1.75
74157	DIP-14	IC - Quad 2 input data select/Dempx.	1.50
74161	DIP-14	IC - Sync. 4-bit counter	2.25
74166	DIP	IC - 8-bit shift register	2.25
74174	DIP	IC - Hex Quad D flip flop	2.25
74175	DIP	IC - Quad D flip flop	1.50
74191	DIP	IC -	3.00
74279	DIP	IC - Quad Set Reset Latch	1.30
74LS00	DIP	IC - Quad 2-Input NAND Gate	.90
74LS02	DIP	IC - Quad 2-Input NOR Gate	.80
74LS04	DIP	IC - Hex Inverter	.90
74LS08	DIP	IC - Quad 2-Input AND Gate	.90
74LS138	DIP	IC - 1 of 8 Decoder Demultiplexer	.80
74LS139	DIP	IC - Dual 2 to 4 Line Decoder	1.50
74LS161	DIP	IC - Preset Binary Ctr	1.50
74LS163	DIP	IC - 4-Bit Counter	1.50
74LS174	DIP	IC - Hex D Flip-Flop	1.70
74LS244	DIP	IC - Octal Buffer-Line Driver	2.00
74LS245	DIP	IC - Octal Bus Transceiver	2.00
74LS263	DIP	IC - Dual 4 Line to 1 Line Multiplexer	2.00
74LS259	DIP	IC - 8-bit Addressable Latch	2.00
74LS273	DIP	IC - Octal Positive Edge Triggered	2.00
74LS365	DIP	IC	2.00
74LS367	DIP	IC - Hex Tri State Line Driver	2.00
74LS374	DIP	IC - Octal Edge Triggered Flip-Flop	1.70
74LS541	DIP	IC - Octal Buffer-Line Driver	2.00
74LS74	DIP	IC - Dual D Flip Flop	1.00
74S04	DIP	IC - Hex Inverter	1.10
CA3081	DIP	IC - Transistor Array	4.95
UDN6118A	DIP	IC - Fluorescent Display Drier	4.95
UDN6184A	DIP	IC - Digit Driver	10.00
ULN2003	DIP	IC - Transistor Array	3.00
ULN2803	DIP	IC - Transistor	5.00
MC14049	DIP	IC - Hex Buffer Inverter	1.70
MC14069	DIP	IC - Hex Inverter, Low Power	2.00
MC14543	DIP	IC - BCD to 7-Segment Decoder	3.00
9602	DIP	IC - Dual monostable multivibrator	3.50
AY-3-8910	DIP-40	Sound processor	6.00

## TRANSISTORS



Item#	Description	Price
MPSA42	Transistor	\$.60
MPSA43	Transistor	.60
MPSA56	Transistor	.60
MPSA70	Transistor	.60
MPSD02	Transistor (2N5401)	.50
MPSD52	Transistor (2N5401)	.50
MPSU05	Transistor	2.50
MPSU07	Transistor (MPSU60)	2.60
MDS60	Transistor (SDS-202) (NTE296)	7.00
2N2905	Transistor	1.00
2N3055	Transistor	2.50
2N3440	Transistor	4.25
2N3584	Transistor	4.95
2N3716	Transistor	4.50
2N3792	Transistor	4.50
2N3904	Transistor	.45
2N3906	Transistor	.45
2N4401	Transistor	.40
2N4403	Transistor	.45
2N5060	Transistor	.95
2N5064	Transistor	1.50
2N5401	Transistor (MPS-DS2)	.65
2N5550	Transistor	.75
2N5875	Transistor	4.00
2N5876	Transistor	4.00
2N5878	Transistor	4.00
2N5879	Transistor	4.00
2N5883	Transistor	8.00
2N6045	Transistor (Use TIP 102)	1.40
2N6057	Transistor	6.00
2N6122	Transistor	2.00
2N6236	Transistor (MCR106-1)	2.00
2N6282	Transistor	8.00
2N6283	Transistor	10.00
2N6284	Transistor	8.10
2N6286	Transistor (2N6287)	8.50
2N6292	Transistor	1.80
2N6345	Transistor	8.50
2N6427	Transistor	.70
2N6558	Transistor	1.30
SDS-201	Transistor (NTE171) (NPN)	5.00
2SC1106	Transistor	8.00
2SD870	Transistor (2SD871)	8.00
2SD1398	Transistor	7.00
2SC1815	Transistor	.60
2SC2482	Transistor	1.00
2SC3039	Transistor	2.20
2SC3040	Transistor	.70
2SC1138	Transistor (2SD478) (TIP 47)	1.70
SE9302	Transistor (Use TIP 102)	1.40
MPSA42	Transistor	.75
MCR106-1	Transistor (SCR lamp driver)	.95
MPSU45	Transistor	3.95
MPSU57	Transistor	3.95
TIP29	Transistor	4.25
TIP30	Transistor	3.00
TIP31	Transistor	1.40
TIP32	Transistor	1.40
TIP36	Transistor	4.95
TIP41C	Transistor	1.50
TIP42	Transistor	1.60
TIP47	Transistor	1.70
TIP102	Transistor	1.40
TIP106	Transistor	1.50
TIP107	Transistor	1.50
TIP110	Transistor	1.50
TIP120	Transistor	1.50
TIP121	Transistor	1.80
TIP122	Transistor (TIP120)	1.50
TIP125	Transistor	2.00

## POWER RESISTORS



Item#	Resistance	Wattage	Price
R5W25	25 ohms	5 watt	1.00
R5W27	27 ohms	5 watt	1.00
R5W100	100 ohms	5 watt	1.00
R5W3K	3 Kohms	5 watt	1.00
R5W47K	4.7 Kohms	5 watt	1.00
R7W100	100 ohms	7 watt	1.00
R10W5	5 ohms	10 watt	1.25
R10W330	330 ohms	10 watt	1.25
R10W600	600 ohms	10 watt	1.25

## RESISTORS

Item#	Resistance	Wattage	Price
R025W10	10 ohms	1/4 watt	\$0.10
R025W47	47 ohms	1/4 watt	.10
R025W68	68 ohms	1/4 watt	.10
R025W330	330 ohms	1/4 watt	.10
R025W470	470 ohms	1/4 watt	.10
R025W680	680 ohms	1/4 watt	.10
R025W1K	1K ohms	1/4 watt	.10
R025W10K	10K ohms	1/4 watt	.10
R025W24K	24K ohms	1/4 watt	.10
R025W47K	47K ohms	1/4 watt	.10
R025W50K	50K ohms	1/4 watt	.10
R025W120K	120K ohms	1/4 watt	.10
R05W680	680Kohms	1/2 watt	.15
R05W330K	330Kohms	1/2 watt	.15
R05W390K	390Kohms	1/2 watt	.15
R2W82	82 ohms	2 watt	.25



## BRIDGE RECTIFIERS



Item#	Description	Price
GIB3502	200V 35 Amp	4.95
KBPC2502	200V 25 Amp	5.25
MDA200-3N253	50V 2 Amp	4.00
VJ248/KBPC802	200V 10 Amp	3.95
KBPC3502L	200V 35 Amp - Lugs	4.95
KBPC3502W	35 A - Wire leads	4.95
CTB-34	Power Supply	3.25

## VOLTAGE REGULATORS

Item#	Package	Description	Price
LM323K	TO-3	5 volt 3A Voltage Regulator	\$4.00
LM383	TO-220	Audio Power Amp	3.50
LM555	DIP	Timer	1.80
LM723	DIP	Voltage Regulator	2.00
LM7815	TO-220	15 Volt 1.5A Voltage Regulator (LM340T15)	1.60
7805	TO-220	5 Volt 1.5A Voltage Regulator (LM340T5)	1.90
7812	TO-220	12 Volt 1.5A Voltage Regulator (LM340T12)	1.90
7912	TO-220	!2 Volt Regulator	1.60

## CAPACITORS

Item #	Value	Volts.	Price	Item #	Value	Volts.	Price
C001M50	.01µF	50	.50	C47M100	47µF	100	1.00
C01M100	.1µF	100	.75	C100M10	100µF	10	.50
C2M	2.2µF	50	.50	C100M200	100µF	200	1.50
C2M250	2.2µF	250	1.00	C220M35	220µF	35	.75
C10M16	10µF	16	.50	C220M50	220µF	50	1.00
C10M25	10µF	25	.50	C330M50	330µF	50	1.00
C10M250	10µF	250	1.00	C470M16	470µF	16	.50
C22M10	22µF	10	.75	C470M200	470µF	200	2.00
C22M35	22µF	35	.75	C640M16	640µF	16	1.00
C22M50	22µF	50	1.00	C1000M35	1000µF	35	3.00
C33M50	33µF	50	1.00	C2200M25	2200µF	25	4.00
C33M160	33µF	160	1.50	C15000M16	15000µF	16	8.00

## RELAYS



Item #	Package	Description	Price
FRL-264	8-pin Cube	BLY/STN Flipper Enable Relay 48VDC	10.00
1395P-2C-24D	8-pin Cube	WMS A/B Relay 24VDC	10.00





# Components

## EPROMS

Erasable Programmable Read Only Memory

Item#	Package	Description	Price
2716	DIP-24	IC - 16kbit EPROM (pulls)	2.00
2532	DIP-24	IC - 32kbit EPROM (pulls)	3.00
2732	DIP-24	IC - 32kbit EPROM (pulls)	2.00
2764	DIP-24	IC - 64kbit EPROM (pulls)	3.00
27128	DIP-28	IC - 128kbit EPROM (pulls)	3.50
27256	DIP-28	IC - 256kbit EPROM (pulls)	4.00
27512	DIP	IC - 512kbit EPROM (pulls)	5.00
27C010	DIP	IC - 1mbit EPROM (pulls)	6.00
27C020	DIP	IC - 2mbit EPROM (pulls)	8.00
27C040	DIP	IC - 4mbit EPROM (pulls)	10.00
27C080	DIP	IC - 8mbit EPROM (pulls)	15.00

## GAME ROM UPDATES

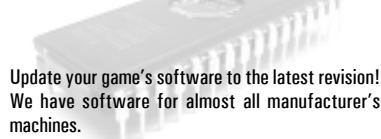

Update your game's software to the latest revision! We have software for almost all manufacturer's machines.

#WPCPROM - WPC EPROM update

(Specify game & IC #'s).....\$25/chip

#PROM - Any other machine update (Spec. game, mfr, & IC #'s)...\$15/chip

## FUSES

These are quality fuses designed to protect your machines from hazardous shorts. Make sure to check your manual and note the correct amperage and fuse type (Fast-blow or slow-blow) before replacing your fuses. The GMA Mini-fuses are commonly found in late-model Williams/Bally Machines.



Amperage	AGC Fast-Blow \$1.95/5-pack	GMA Mini FB \$1.95/5-pack	MDL Slow-Blow \$3.95/5-pack
.1	AGC1-10	GMA1-10	-
.125	AGC1-8	GMA1-8	-
.187	AGC3-16	-	MDL3-16
.25	AGC1-4	GMA1-4	MDL1-4
.50	AGC1-2	GMA1-2	MDL1-2
.75	AGC3-4	GMA3-4	MDL3-4
1	AGC1	GMA1	MDL1
1.5	AGC112	GMA112	MDL112
2	AGC2	GMA2	MDL2
2.5	AGC212	GMA212	-
3	AGC3	GMA3	MDL3
3.5	AGC312	GMA312	MDL312
4	AGC4	GMA4	MDL4
5	AGC5	GMA5	MDL5
6	AGC6	GMA6	MDL6
7	AGC7	GMA7	MDL7
8	AGC8	GMA8	MDL8
10	AGC10	GMA10	MDL10
15	AGC15	GMA15	MD15
20	AGC20	-	MDL20
25	AGC25	-	MDL25
30	AGC30	-	-

## DIODES



Item#	Description	Price	Item#	Description	Price
MR751	Diode	\$1.50	1N4764	Diode	.70
1N4001	Diode	.25	1N5275	Diode	1.40
1N4004	Diode	.25	1N5359	Diode	1.60
1N4006	Diode	.20	1N5401	Diode	.50
1N4007	Diode	.16	1N5404	Diode	1.00
1N4148	Diode	.30	1N5990	Diode	.50
1N4734	Diode	.50	R712E	Diode (TO-3 package)	8.95
1N4759	Diode	.50			

## SIP SOCKETS

These single inline pin (SIP) machine pin sockets are the only chip socket you need to stock. They are 'snappable' to any length and can accommodate any SIP or DIP (dual inline pin) IC from 2 to 40 pins. They are superior to conventional sockets because they allow access for soldering between the rails on double-sided circuit boards. They come in 20-pin strips.

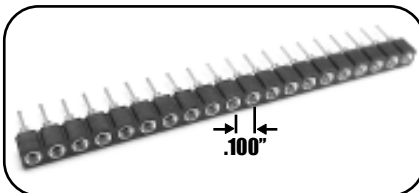

#SIP20 - SIP Socket, 20-pins ..... \$1.25

## OPTOS

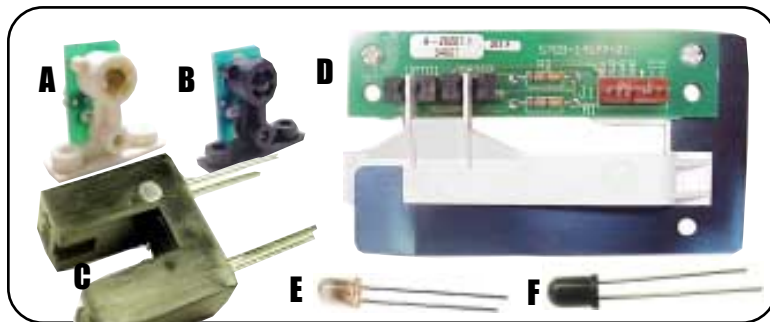
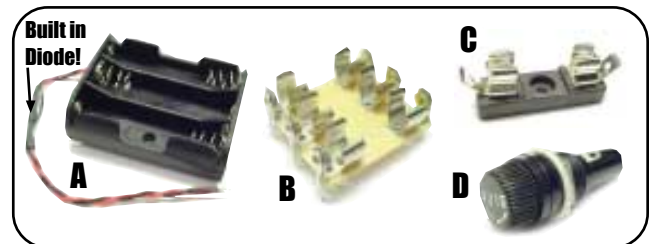

Fig Item #	Description	Price
A <b>A-16908</b>	WMS IR LED Assy.	<b>\$3.00</b>
B <b>A-16909</b>	WMS IR Opto receiver Assy	<b>3.00</b>
C <b>5490-12451</b>	IR Opto/LED pair, (used in Twilight Zone)	<b>6.95</b>
C <b>5490-10159</b>	IR Opto/LED pair	<b>6.95</b>
D <b>A-17316</b>	WMS Flipper opto board	<b>19.95</b>
E <b>5671-12731</b>	IR L.E.D.	<b>2.95</b>
F <b>5163-14114</b>	IR Opto detector	<b>2.95</b>

## BATTERY & FUSE HOLDERS



- A) Stop the rot! For ANY Bally, Gottlieb, or Stern CPU board. End your NiCad or other board mounted battery corrosion problems permanently with this remotely mounted, 3 AA battery replacement kit. No board modification thanks to the built-in-diode protection.
- B) Williams battery holder
- C) Replace your corroded surface-mounted fuse holders for more reliable connections.
- D) These chassis mounted fuse holders are commonly found in power supply cases.

Fig Item #	Description	Price
A <b>RBH073</b>	Remote Battery Holder	<b>\$4.95</b>
B <b>WMSBATT</b>	WMS Battery Holder	<b>4.95</b>
C <b>FHSM</b>	Surface mounted fuse holder	<b>2.50</b>
D <b>FHCM</b>	Chassis mounted fuse holder	<b>2.50</b>



## NI-WUMPF **Free Shipping!** on this item

Gottlieb System 1 Replacement Board



- Fits Gottlieb System 1 Machines:**
- Buck Rogers
  - Charlie's Angels
  - Cleopatra
  - Close Encounters
  - Countdown
  - Dragon
  - Genie
  - Incredible Hulk
  - Joker Poker
  - Pinball Pool
  - Roller Disco
  - Sinbad
  - Solar Ride
  - Torch
  - Totem

At last, an easy replacement for those unreliable, unobtainable, un-repairable old System 1 CPU's. The wizards at *Ni-Wumpf* (an inside joke for Monty Python aficionados) recreated this half size board from ground up and crammed ALL System 1 games into its dip-switch selectable memory! This board is a *PLUG-IN* replacement for the CPU board. Simply change the switch settings and move the board from game to game. As an added bonus, extensive diagnostic

routines have been added to each game's software. Since it is constructed of easy-to-find parts, this board makes an excellent long-term investment for your Gottlieb machine. Comes with a detailed manual describing set up, operation, and diagnostics, schematics, and a 30-day warranty.

**#U-NIWUMPF - Ni Wumpf CPU**  
**\$184.95**

## EPROM PROGRAMMING



**Free Shipping!**  
on this item

**A) EMP-10 Programmer:** The NEEDHAM'S PB-10 is the most cost effective and versatile "chip burner" on the market. If you have a PC compatible computer of any kind, you can plug this card into your parallel printer port and be reading, copying, editing, and programming EPROMs (erasable programmable read only memory chips) in minutes. The PB-10 reads and writes all chip families used in pinball machines and has easy to use, menu driven software. Features a 2 foot cable, Zero Insertion Force chip socket, software & instructions on 3.5" floppy and booklet. Programs up to 4 meg EPROMS and larger with optional adapters. One year warranty.

**B) Datarase EPROM eraser:** This small device will simultaneously erase up to four EPROMS in just minutes. Powered by the plug-in wall adapter (included) the small ultraviolet light exposes the chips for clean complete erasures. An excellent companion to the PB-10 programmer.

**A) #EMPIO - EMP-10 Parallel Port Programmer ..... \$219.95**

**B) #EE4 - EPROM Eraser, 4-chip ..... \$39.95**

**#EPCOMBO - EMP-10 programmer AND Eraser ..... \$249.95**

## WILLIAMS HI-VOLTZ UPGRADE



This module is an excellent replacement for all Williams and United electronic machines made from 1977 to 1988. It plugs on top of and replaces the original high voltage circuitry. Installation takes about 15 minutes, even for the novice. Made of commonly available parts, it protects your expensive displays with its well-regulated, fused outputs. Has LED indicators and comes with a 6-month warranty!

**#WHVK - Hi-Voltz Module.**  
**\$39.95**

## POP BUMPER DRIVER BOARD



From the folks at PINBALL LIZARD comes a brand new replacement for GOTTLIEB Part #A-19741 with one difference — this one WORKS! These boards have been redesigned for reliable bumper popping into the next century.

**#GTB80PB - GTB Pop Bumper Board ..... \$22.95**

## GTB HAUNTED HOUSE UPKICKER UPGRADE

The engineers at PINBALL LIZARD heard and heeded the cries of HAUNTED HOUSE owners the world over who said their upkickers would not. They made this new kit that includes a new, redesigned pop bumper board, wiring, hardware, and detailed installation instructions for restoring power to the upkicker assembly.



**#U-HHUK - Haunted House Upkicker Kit ..... \$29.95**

**PinTip:**  
**The Prop Rod**

Avoid using the playfield single prop rod because it can twist the plywood playfield and induce cracks in your playfield paint! Instead, swing the playfield up and lean it against the backbox.

## BACKGLASS TRIM

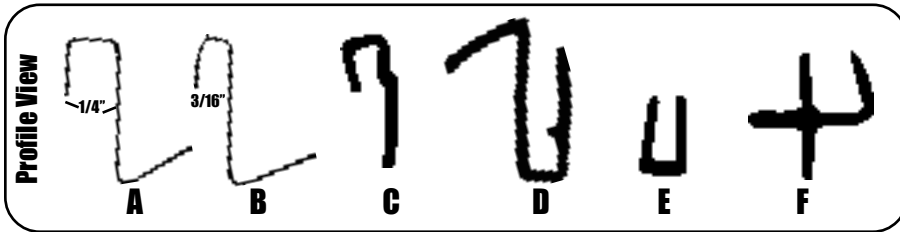
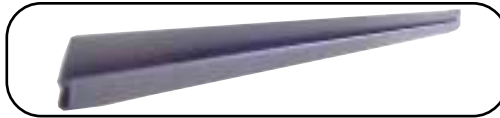

Fig/Item #	Description	Length	Price
<b>A LT14</b>	Chrome metal glass lift trim, 1/4" glass	28-1/2"	<b>\$20.00</b>
<b>B LT316</b>	Chrome metal glass lift trim, 3/16" glass	28-1/2"	<b>20.00</b>
<b>C 03-8228-1</b>	Side trim, WMS glass	22"	<b>5.95</b>
<b>C 03-8228-2</b>	Top trim, black plastic, WMS glass	27"	<b>5.95</b>
<b>C 03-8228-3</b>	Top trim, black plastic, WMS Safecracker	17-15/16"	<b>5.95</b>
<b>D 03-8229-1</b>	Lift trim, black plastic, standard	27"	<b>5.95</b>
<b>D 03-8229-4</b>	Lift trim, black plastic, narrow	22"	<b>5.95</b>
<b>E 545-5018-15</b>	Top trim, black plastic, Sega/D.E.	26"	<b>5.95</b>
<b>E 545-5018-07</b>	Side trim, black plastic, Sega/D.E.	21-5/8"	<b>5.95</b>
<b>F 545-5017-01</b>	Lift trim, black plastic, Sega/D.E.	26"	<b>5.95</b>
<b>- 545-5021-02</b>	Lift trim, black plastic, Sega/D.E.	26-7/16"	<b>5.95</b>

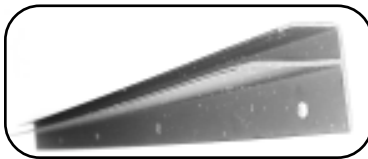

## PLAYFIELD GLASS REAR MOLDING

Item #	Description	Length	Price
<b>03-8091</b>	Rear glass molding	20-5/16"	<b>\$7.95</b>
<b>03-8091-2</b>	Wide rear glass molding	23"	<b>7.95</b>

## MYLAR® SHIELDS

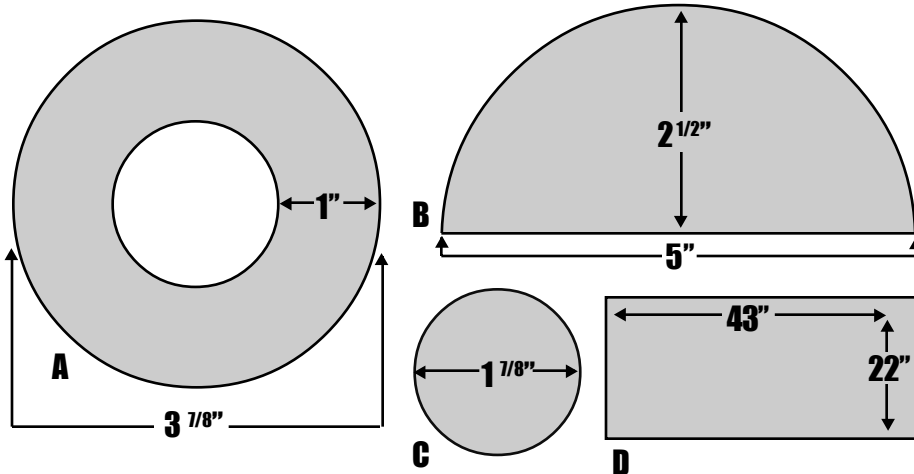

Use the half circles for protection of heavy traffic areas like slingshots, or trim them to fit spots near saucer kickouts, targets, rebound rubbers, etc. Use the rings to replace worn or missing plastic shield around pop bumpers. The spots are great for areas like ball kick-outs and ramp exits. For total playfield protection, remove all playfield components and install a full sheet and trim to keep your precious playfield permanently pristine!

Fig/Item #	Description	Price/ea	Price/10
<b>A MFC</b>	Mylar, Pop bumper full circle	<b>\$0.89</b>	<b>\$7.00</b>
<b>B MHC</b>	Mylar, Half-circle (Sling-shot)	<b>0.89</b>	<b>7.00</b>
<b>C MSC</b>	Mylar, spot circle	<b>.40</b>	<b>3.00</b>
<b>D MFS</b>	Mylar, full 22"x 43" pre-cut sheet	<b>17.00</b>	
<b>- MFT</b>	Mylar, 22"wide by the foot	<b>4.95/ft</b>	<b>35.00</b>

## CLIPS & HOLDERS

These 3/4" diameter clips fasten securely to a flat surface with the included adhesive pad on the bottom. They make routing wires easy since they clip open and shut instantly. Perfect for any re-wiring projects.

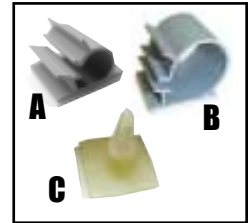

Fig Part #	Description	Price
<b>A 03-7722-4</b>	1/4" Kwik Klip w/ adhesive	<b>\$.75</b>
<b>B 03-7722-12</b>	3/4" Kwik Klip w/ adhesive	<b>.75</b>
<b>C 03-8088-1</b>	Board mount w/ adhesive	<b>.50</b>

## HEAT SHRINK TUBING



Do your wire splices leave a little bit to be desired?

With heat-shrink tubing, every splice can be permanent and safe from shorts.

Heat shrink tubing is the answer to obsolete electrical tape. It adds a professional touch to any connection. When exposed to heat from a lighter or heat gun, it shrinks to 50% of its original size. Available in 1/4" and 1/8" diameters.

<b>HST14</b> - Heat Shrink Tubing, 1/4" Dia.	<b>\$2.00/ft</b>
<b>HST18</b> - Heat Shrink Tubing, 1/8" Dia.	<b>1.50/ft</b>

## CABLE TIES

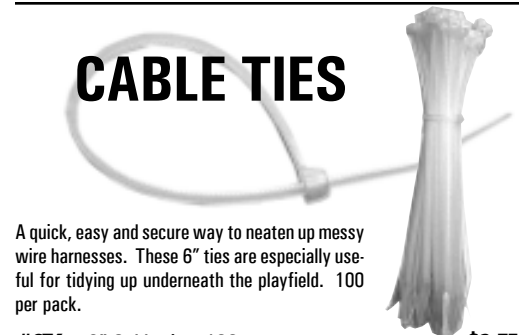

A quick, easy and secure way to neaten up messy wire harnesses. These 6" ties are especially useful for tidying up underneath the playfield. 100 per pack.

<b>#CT6</b> - 6" Cable ties, 100 count	<b>\$2.75</b>
--	---------------

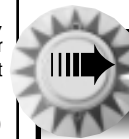

### PinTip: Airball!

Place 1" diameter flat washers under the sling-shot playfield plastics to prevent an "airball" from chipping the corners. Many new machines now come with this simple fix from the factory.



## TOOLBOX NECESSITIES

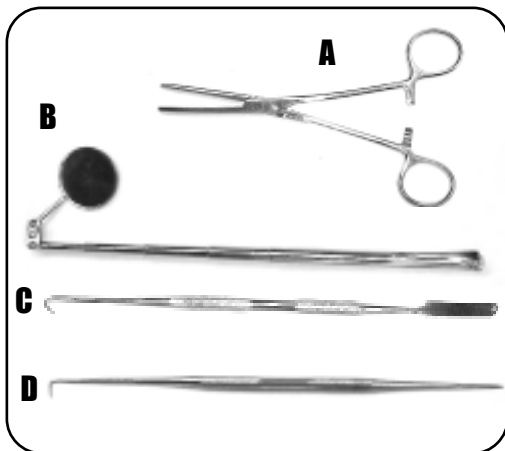

**A) Clamping Forceps** - These 6" medical-style locking forceps are great for clamping things, retrieving small parts, and holding parts while soldering.

**B) Telescoping Mirror** - At only 5" folded up, this portable handy device telescopes to 20" to help take a peek in those hard-to-get-to areas in your machines.

**C) Spring Hook** - Another necessity to help install and remove any of the zillions of springs in a pinball machines.

**D) Scribe** - You can't master the four P's of pinball repair (Poking, Prying, Punching, and Probing) without this handy universal tool. A must for any toolbox.

- #77-FC6 - 6" Forceps ..... \$2.95
- #77-TSM - Telescoping Mirror ..... 2.95
- #77-SHK - 6" Spring Hook ..... 2.50
- #77-SCB - Scribe ..... 2.50

## ROUND PIN EXTRACTORS

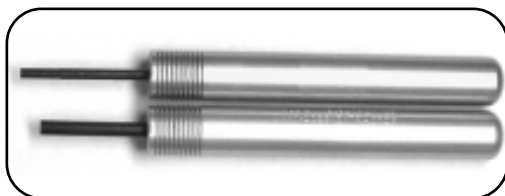

There's no way on earth to remove a round pin (male or female crimp terminal) from its housing without destroying it, the housing, or your hands — unless you use this tool. It pushes the pin's locking tabs back to allow clean removal of the pin. The .093" diameter pin tool is the most commonly used on all pinball machines, while the smaller .062" pin tool is useful on early WILLIAMS solid state harness connectors.

- #77-PET93 - .093" pin extractor ..... \$14.95
- #77-PET62 - .062" pin extractor ..... 14.95

## PICK UP TOOLS

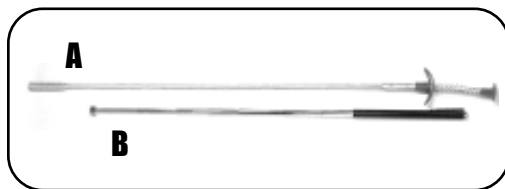

**A) Claw Pickup Tool** - This tool is a must for retrieving dropped parts in your machine. 24" flexible shaft.

**B) Pocket Magnetic Pickup Tool** - A handy item to have around, this 6" telescopically expands to 36".

- #77-CPUT - Claw Pickup tool ..... \$3.50
- #77-PPUT - Pocket Magnetic Pickup Tool ..... \$3.25

## TAMPER-PROOF TORX BIT

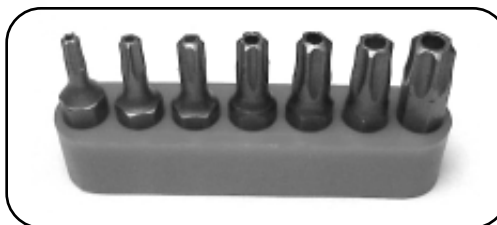

A necessary tool for all late model coin-op games. 7 piece set includes TORX sizes T-10 through T-40. These 1/4" drive bits have hollow points to fit the nipples on TORX security screws.

- #77-TTB - TORX Bit Set ..... \$7.95

## INCLINOMETER

Does your pinball machine make the grade? Manufacturers design their machines to have a downward pitch of between 6 and 7 degrees. You'll know for sure if it's playing to spec with this neat little American made angle finder. Measures all angles in 1° increments up to 90°.



- #77-NCL - Inclinometer ..... \$9.95

## INFRARED DETECTOR PEN



This tool is perfect for troubleshooting opto problems such as those used in late-model Williams, Bally, Sega, and New Stern machines. It has a green led on the end that shifts to yellow when the pen is pointed at a source of infrared light.

- #77-IRDP - Infrared Detector Pen ..... \$9.95

## SWITCH ADJUSTER KIT



3 piece set contains an assortment of different off-set adjuster tools. Absolute necessity for adjusting those leaf switches in tight spots!

- #77-SWK - Switch Adjusters ..... \$5.95

## CLEANING BRUSHES



This brush set contains three types of brushes: Nylon, Brass, and Stainless Steel. Excellent for cleaning small parts and removing corrosion and rust.

- #77-3PBS - 3 pc Brush Set ..... \$2.50

## ALLIGATOR TEST CLIP SET

Not a complex tool, but certainly useful. Each pack has ten 12" jumper wires in red, green, yellow, black, and white.



- #77-ATCL - Test Clip Leads ..... \$3.50/pk.

## SEGA/STERN/D.E. BACKBOX KEY

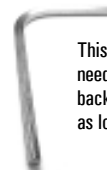

This often-lost large hex-wrench key is needed to quickly and safely secure the backbox in an upright position, as well as lower it for shipping.

- #77-0001-00 - Backbox Key ..... \$4.95

## ABRASIVES

**A) Socket Cleaning Stick:** A crayon sized (3" x 5/16" diameter) rubber stick impregnated with abrasive material. Just right for scrubbing corrosion inside bayonet lamp sockets.  
**B) Flexstone Abrasive Strip:** Just the right tool for burnishing and cleaning corroded or cruddy contacts, especially on electro-mechanical machines.

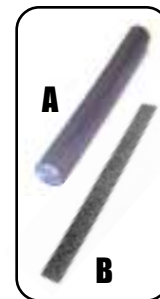

- A) #77-SCS** - Socket cleaning stick ..... \$3.95
- B) #77-FXT** - Flexstone ..... \$1.00

# MISSION PINBALL RESOURCE KIT

**CRITICAL**

It's Friday night and your pinball machine is down. The 'Mission: Critical' parts kit to the rescue! It contains over \$175 worth of the parts you're going to need to bring your machine back to life! This "first-aid" kit for pinball machines contains a slew of coils, springs, balls, flippers, plungers, fuses, optsos, and other various critical

parts for late-model Williams and Bally machines. This preventative maintenance kit will have what you need when you need it.

The 'Mission: Critical' Pinball Resource Kit has all of THIS:



**\$175**  
worth of  
parts!

- (4) EOS Switches
- (2) Left Crank Links
- (2) Right Crank Links
- (2) Flipper Coil Stops
- (2) FL-11629 Coils
- (2) FL-11630 Coils
- (1) AE-23-800 Coil
- (3) 01-5492 Armature Links
- (3) 01-5493 Armature Links
- (2) A-17316 Flipper Opto Assy's.

- (4) Coil Sleeves
- (2) Coil Plunger Assy's
- (4) Pop Bumper Springs
- (4) Flipper Retractor Springs
- (3) 1 1/16" Pinballs
- (2) Drop Targets
- (1) Microswitch
- (10) Ball Shooter Tips
- (2) Opto Transmitters
- (2) Opto Recievers

- (6) 4A Fuses
- (6) 5A Slow-Blo Fuses
- (6) 6.3A Fuses
- (6) .63A Fuses
- (4) Inner Shooter Rod Springs
- (4) Outer Shooter Rod Springs
- (2) Shooter Rods
- (2) Shooter Rod Sleeves
- (2) Pop Bumper Ring Assy's
- (2) Flipper Bats w/ Shafts

#A-13524-9 - Mission: Critical Kit ..... \$149.95

**PinTip: Heat Shrink it!**

Electrical tape is DEAD! Use heat shrink tubing to make more reliable and better looking wire connections, especially on coils. It doesn't come off like electrical tape.

**PinTip: 'Shroom Shooter**

Don't operate your ball shooter with a worn or missing rubber plunger tip. The impact of the steel shooter rod against the ball will mushroom the end of the rod. Now it's impossible to remove the rod without cutting it!

**PinTip: Housings**

Replace connector housings that have burn or discolored spots so you'll be able to see if the connector overheats in the future.

**PinTip: Fuse Follies**

**Never** replace blown fuses with the wrong current or type! Fuses are designed into circuits so that they are damaged when something goes wrong, not expensive components. Always try to find out why a fuse has blown when replacing it.



# Moving Tools



## The Classic PinLift



This dolly has been one of our shop favorites for years. It makes attaching and removing pinball legs a snap. Not only do the heavy-duty casters allow effortless movement of your machine in every direction, but its durable construction will provide decades of service. A simple step on the lever will raise the heaviest of machines, and the built-in shock absorber gently lowers your machine when you are finished. It stores easily underneath any machine.

**Free Shipping!**  
on this item

#PBCL - Pinball lift **\$399.95**

## PINBALL SKATES



**Free Shipping!**  
on this item

The newest device for easily moving metal leg pinball machines! One pair of lightweight (only 5 lbs ea!), portable **Pinball Skates** clips to the front and rear legs and makes maneuvering machines effortless. Just slide a skate between the game's legs, lift, clip, and roll! Works great on rental truck ramps!

#PBS Pinball Skates(pair) **\$169.00**

## Two-wheel Pinball Dolly



**MACHINE MOVING HAS NEVER BEEN EASIER!**

We've tried them all... this is the easiest to use and least expensive pinball moving cart available. Anyone can move a 400 pound pinball machine with one hand! The all-steel cart has big wheels that can go where the others can't. It has a tough enamel finish, and the wheels are the only moving parts. The two-position handle and axle adjust to any machine. It weighs only 33 pounds and is small enough to fit in the trunk of a car! It's cheaper than back surgery and a lot more fun.



**Free Shipping!**  
on this item

#PBTW - Two-wheel Pinball Dolly **\$225.00**

## PinTip: Sun: The Enemy

Don't leave your machine exposed to direct sunlight outdoors on a hot day without covering your playfield (especially in a pickup truck bed). Your plastics could be melted!

## PROTECT YOUR MACHINE

This VERY heavy gauge vinyl pinball cover protects your machine from the elements while being transported in an open vehicle or placed in storage. Form fit covers all machines with no disassembly.

#PMC - Pinball Cover..... **#69.95**

## STRETCH WRAP



Whether it's bad weather or rough moving conditions, this handy stretch wrap is great for waterproofing and protecting your machines on the move. It pulls tight and clings to itself for a quick covering on just about anything, especially your pinball machines. Keep a roll in the truck "just in case."

#PSW - Protective stretch wrap..... **\$15.00**



