



SERVICE MANUAL

FOR

6531 SERIES

ELEVATOR AIR CONDITIONERS

TABLE OF CONTENTS

I.	Warnings	2
II.	Component Match-Up	2
III.	Specifications And Unit Identification	3
IV.	Wall Thermostat Operation (7330-324)	4
V.	Sequence Of Operation	5
VI.	Electrical Components Identification	6
VII.	Quick Troubleshooting Tips	7
VIII.	Component Checkout	7
IX.	Electrical Flow Charts	11
X.	Wiring Diagram	16

I. WARNINGS

IMPORTANT NOTICE

These instructions are for the use of qualified individuals specially trained and experienced in installation of this type equipment and related system components.

Installation and service personnel are required by some states to be licensed. PERSONS NOT QUALIFIED SHALL NOT INSTALL NOR SERVICE THIS EQUIPMENT.

NOTE

The words "Shall" or "Must" indicate a requirement which is essential to satisfactory and safe product performance.

The words "Should" or "May" indicate a recommendation or advice which is not essential and not required but which may be useful or helpful.

WARNING - SHOCK HAZARD

To prevent the possibility of severe personal injury or equipment damage due to electrical shock, always be sure the electrical power source to the appliance is disconnected during installation.

CAREFULLY FOLLOW ALL INSTRUCTIONS AND WARNINGS IN THIS BOOKLET TO AVOID DAMAGE TO THE EQUIPMENT, PERSONAL INJURY OR FIRE.

WARNING

Improper installation may damage equipment, can create a hazard and will void the warranty.

The use of components not tested in combination with this unit will void the warranty, may make the equipment in violation of state codes, may create a hazard and may ruin the equipment.

II. COMPONENT MATCH-UP

1. 6531B692 Package Air Conditioner.
2. 6531-625 Accessory Kit (Optional)

III. SPECIFICATIONS AND UNIT IDENTIFICATION

PACKAGE AIR CONDITIONER MODEL NUMBER BREAKDOWN

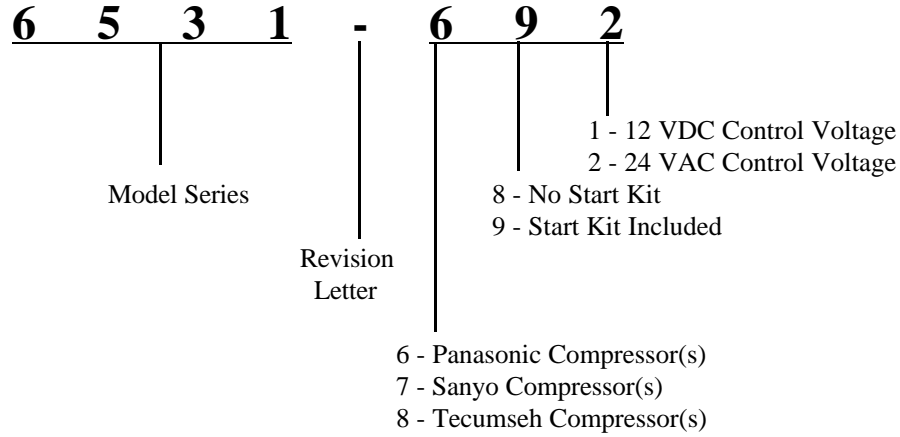

SPECIFICATIONS

USE THERMOSTAT MODEL 7330-324 SUPPLIED WITH ACCESSORY KIT #6531-625		
115	60	1
VOLTS AC	HZ	PHASE
COMPRESSOR MOTOR (THERMALLY PROTECTED)		RLA 6.9
		LRA 34.0
ELECTRIC HEATER BLOWER/FAN MOTOR		FLA 12.5
	1/3 H.P.	FLA 2.9
MINIMUM CIRCUIT AMPACITY		AMP 20
MAXIMUM OVERCURRENT PROTECTIVE DEVICE		AMP 20
R-22 CHARGE WEIGHT		OZ 14.75
MINIMUM SUPPLY CONDUCTOR GAUGE (COPPER) UTILISER DES FILS D'ALIMENTATION EN CUIVRE		#12
MAXIMUM EXTERNAL STATIC PRESSURE .5 IN. H₂O		
UNIT	WEIGHT	75 LBS.
6531B692	LENGTH	22 1/8
	DEPTH	18 1/8
	HEIGHT	19 3/4
ACCESSORY KIT	WEIGHT	28 LBS.
6531-692	LENGTH	15 7/8
	DEPTH	16 9/32
	HEIGHT	10

IV. WALL THERMOSTAT OPERATION FOR 7330-324

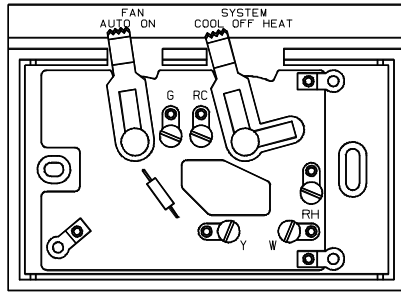

SUB-BASE

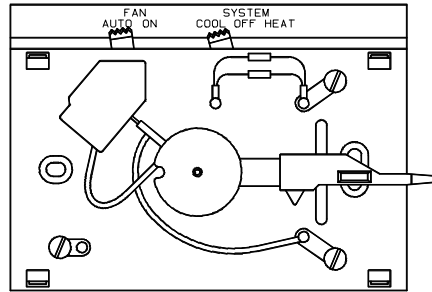

BI-METAL PLATE

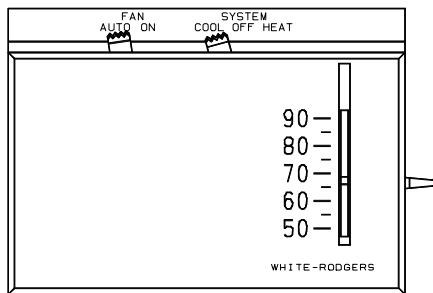

COMPLETE ASSEMBLY
BI-METAL PLATE SCREWED
TO SUB-BASE AND WITH
SNAP-ON COVER

1. 1°F rated differential
2. Shrouded contacts
3. Heat anticipator - .15 - .8 amp (self-adjusting)

Wiring: RC - Control Wiring Supply - A/C
 RH or 4 - Control Wiring Supply - Heat
 Y - Compressor Relay Coil
 G - Fan Relay Coil
 W - Furnace

THERMOSTAT OPERATION

<div style="display: inline-block; width: 15px; height: 15px; background-color: black; margin-right: 5px;"></div> SHOWS POSITION OF SWITCH					7330-324 OPERATION
SYSTEM HEAT	OFF	COOL	FAN AUTO	ON	
<input type="checkbox"/>	<input checked="" type="checkbox"/>	<input type="checkbox"/>	<input checked="" type="checkbox"/>	<input type="checkbox"/>	Operation of all components is stopped.
<input type="checkbox"/>	<input checked="" type="checkbox"/>	<input type="checkbox"/>	<input type="checkbox"/>	<input checked="" type="checkbox"/>	Cooling fan runs continuously. No compressor operation.
<input type="checkbox"/>	<input type="checkbox"/>	<input checked="" type="checkbox"/>	<input checked="" type="checkbox"/>	<input type="checkbox"/>	Cooling blower and compressor cycle with thermostat.
<input type="checkbox"/>	<input type="checkbox"/>	<input checked="" type="checkbox"/>	<input type="checkbox"/>	<input checked="" type="checkbox"/>	Cooling blower operates continuously. Compressor cycles with thermostat.
<input checked="" type="checkbox"/>	<input type="checkbox"/>	<input type="checkbox"/>	<input checked="" type="checkbox"/>	<input type="checkbox"/>	Cooling blower operates continuously at high speed. Compressor cycles with thermostat.
<input checked="" type="checkbox"/>	<input type="checkbox"/>	<input type="checkbox"/>	<input type="checkbox"/>	<input checked="" type="checkbox"/>	Heating system cycles from thermostat. Cooling fan operates continuously.

V. SEQUENCE OF OPERATIONS

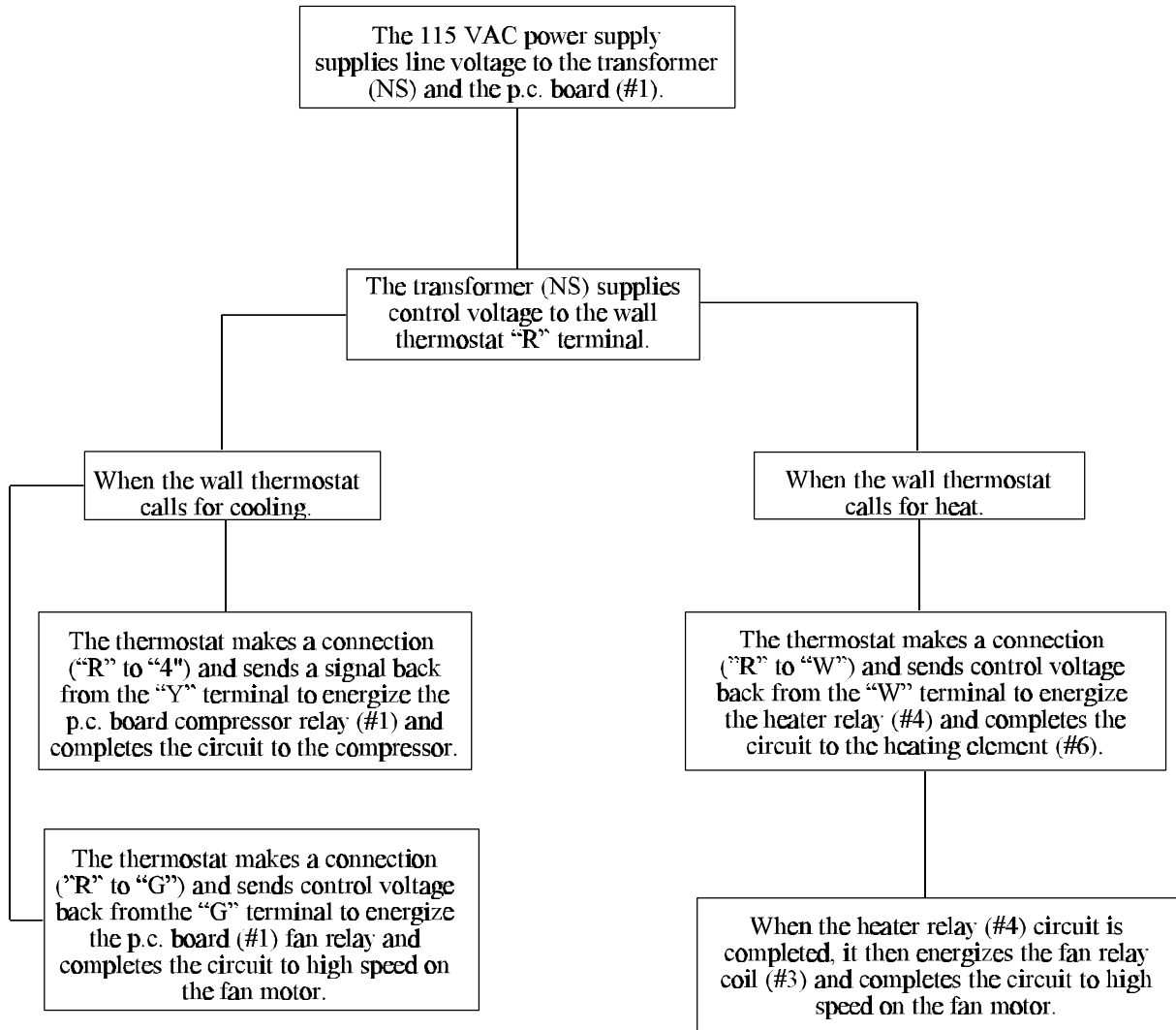

VI. ELECTRICAL COMPONENTS IDENTIFICATION

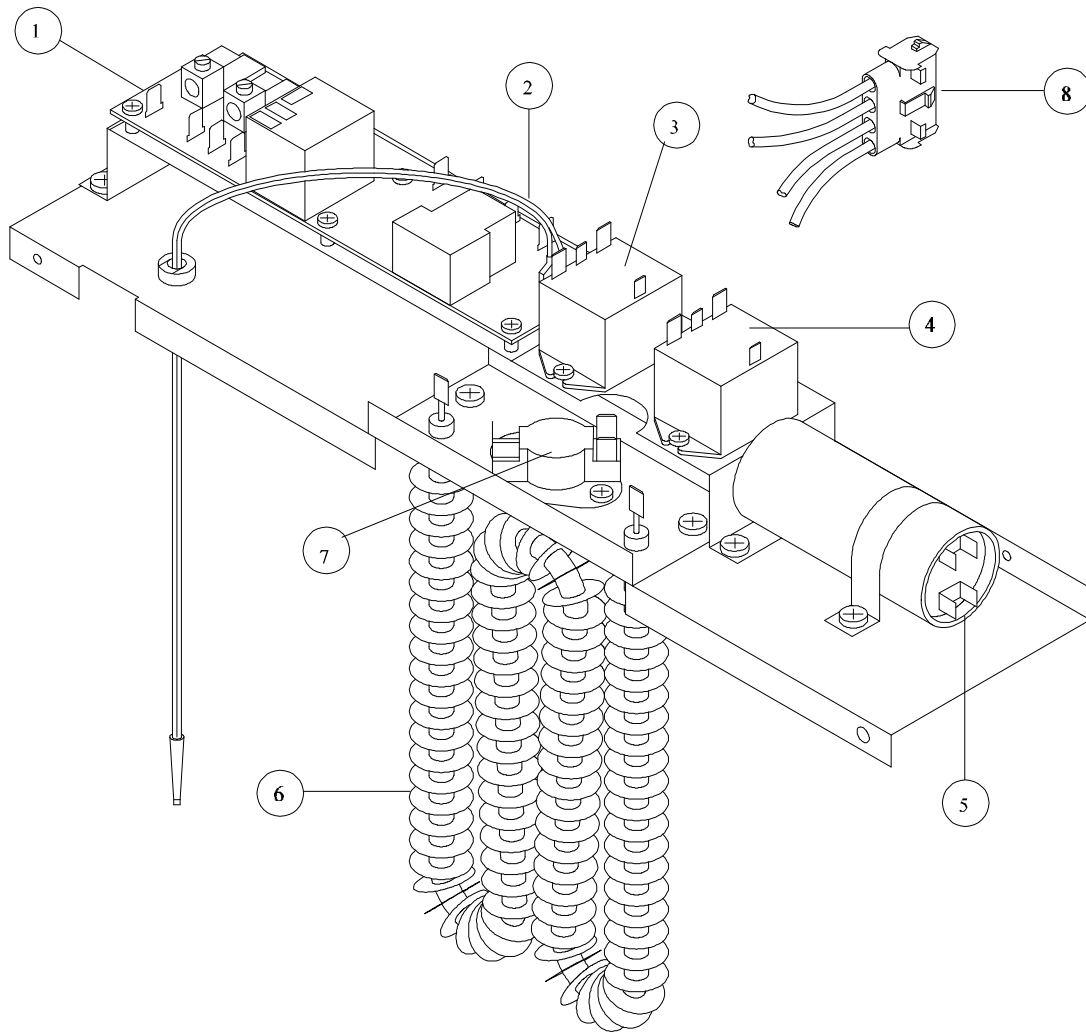

<u>PART #</u>	<u>DESCRIPTION</u>
1	Control Board
2	Coil Sensor
3	Fan Relay
4	Heater Relay
5	Start Capacitor
6	Heat Element
7	Limit Switch
8	Plug Assembly
ns	Transformer
ns	Run Capacitor
ns	Fan Capacitor

VII. QUICK TROUBLESHOOTING TIPS

SYMPTOMS	CAUSES
Fan runs, no compressor operation.	Insufficient voltage to the unit, wiring, thermostat, p.c. board, open thermister, start capacitor, run capacitor, start relay, open overload, compressor.
Heat or compressor runs. No fan operation.	Wiring, thermostat, fan capacitor, fan motor. P.C. board if the compressor runs. Fan relay if the heating element works.
Nothing runs, no compressor, no fan, no heat.	No a/c voltage, transformer, thermostat.
Fan runs, no heat.	Wiring, thermostat, heater relay, open limit switch, open heat element.
Compressor runs, fan runs, insufficient cooling.	Air flow restrictions, high ambient temperature, (undersized) too much heat gain, refrigerant system low charge, compressor. (IF YOU HAVE NOT BEEN PROPERLY TRAINED IN REFRIGERATION SEALED SYSTEM REPAIRS, DO NOT ATTEMPT TO BREAK INTO THE SYSTEM.)

VIII. COMPONENT CHECKOUT

THINK SAFETY

1. Power Supply - from Commercial Utility

1) Wire Size

The power supply to the air conditioner must come through a circuit breaker or time delay fuse. The power supply must be 20 amperes and 12 AWG wire minimum. Any size larger wire at any time may be used and **should** be used if the length of the wire is over 32 feet.

2) Color Code

The electric power from the electric service panel should be delivered through a 3 conductor cable and the Service Technician should check to be sure the color code is correct. The electrician probably installed the cable with the colors according to code, but don't bet your life on it.

- a) The wire with black insulation is the hot wire and there should be 115 volts (domestic USA) between it and either of the

other wires. All switches, fuses, circuit breakers, disconnects, etc. should be in this line.

- b) The wire with the white insulation is the neutral. There should be 115 volts (domestic USA) between the neutral and the hot (black) wire, but there should be 0 volts between the neutral and the ground (the green wire or the frame of the air conditioner). **There must be no switches, fuses, disconnects, etc.** of any kind in the neutral wire.

- c) The third wire may be covered with green insulation or it may be a bare metal wire. It is the ground wire. There must be 115 volts (domestic USA) between this wire and the hot (black) wire and 0 volts between it and the neutral (white) wire. The ground wire must be securely fastened to the air conditioner cabinet. A green headed screw is provided for this purpose.

3) Voltage

The voltage (electrical pressure) at the unit should be 115 volts (domestic USA) and all electrical components will perform best at the correct voltage. However, the voltage will vary and the air conditioning system will perform satisfactorily within plus or minus 10% of the rated (115) voltage (domestic USA). Therefore, the voltage has to be between 103.5 volts and 126.5 volts.

2. Power Supply - Generated By On-board Motor Generator

If the power supply for the recreational vehicle is supplied by an on-board motor generator, its wiring may be identical to the commercial power described above.

There are, however, some motor generators on which both the current carrying leads are insulated from the ground. That is to say; there is no grounded neutral, so there will be 115 volts (domestic USA) between the black and white leads, but there will be 0 volts between either lead and ground.

WARNING: The service technician must keep in mind when checking to make sure that the power is turned off – check only between the hot (black) lead and the neutral (white) lead. The black lead could still be hot even though there is 0 volts between it and ground.

3. Compressor Motor

The compressor motor is located inside the hermetic compressor housing and is therefore, not accessible for service or visual observation in the field. However, the motor winding condition can be analyzed by using an ohm meter. Be sure to remove all the leads from the compressor terminals before making this check.

1. If the resistance between any two terminals is 0 ohms, the motor windings are shorted.
2. If the resistance between any terminal and the compressor housing is anything but infinity, the winding is grounded.

4. Overload Switch

Mounted on the outside of the compressor housing is a two terminal Overload switch. The switch is connected in series with the common terminal. If the switch opens, it will cut the power to the compressor motor. The switch will open as the result of either or both of two conditions that could be harmful to the compressor.

1) High Amperes (Current)

The switch contains a heater which increases in temperature as the current increases. The higher temperature warps the switch and will cause it to open before the windings reach a dangerous temperature.

2) High Temperature (Thermal)

The switch is clamped tightly against the compressor housing and located close to the windings. Therefore, as the windings reach a higher temperature, it takes less current to cause the switch to open.

As can be seen, the switch is always affected by a combination of current to the compressor and winding temperature.

5. Fan Motor

The air conditioning unit has **one** double end shaft fan motor. On one shaft end is mounted a centrifugal or squirrel cage blower which draws air (return air) out of the recreational vehicle and blows the conditioned air down into the recreational vehicle. On the other shaft end is mounted an axial flow or propellor type fan which circulates outdoor air through the condenser coil.

An important step in installing a replacement fan motor is to check the direction of rotation before it is installed. On all models, the condenser fan pulls the air through the coil.

Fan Motor Check Procedure

If a fan motor refuses to perform properly, it can be checked in the following manner:

1. Be sure the motor leads are connected to the proper points –
 - a) The black wire from the motor connects to a black wire inside a wire nut then the black wire connects through the disconnect plug to the selector switch. The red wire from the motor connects to a red wire in a wire nut then the red wire connects through the disconnect plug to the selector switch.
 - b) The white wire from the motor connects to a white wire in a wire nut then the white wire connects through the disconnect plug to the thermostat.

- c) The brown wires from the motor connect to the fan capacitor.

- 2. To check the motor winding resistance, carefully check the resistance between each of the wires and ground (preferably a copper refrigerant tube for a good connection). These readings must be infinity. Any continuity means the windings are grounded.

If there is a reading of 0 between any two leads, the motor is shorted and is no good. If there is a reading of infinity between any two leads, the winding is open and the motor is no good.

6. Relays

The low voltage relays are used in the control circuits to close or open a set of high voltage contacts. When this happens, it either makes or breaks a circuit. To check the relay you must first; 1) shut the power off to the unit, 2) take the line voltage wires off the relay, 3) apply 24 volts to the coil side of the relay, and 4) take an ohm-meter and check to see if the contacts open and close.

7. Transformers

The transformer is used in the circuit to convert 115 VAC and step it down to 24 VAC. To check the transformer, simply take a voltmeter and check for 24 VAC between the red and blue wires coming from the transformer.

8. Heating Element

The heating element is a resistance heater of 1600 watts (5600 BTUH) capacity and is connected across the line when the selector is set for heating and the thermostat is calling for heat. The current draw of the heater (element only) will be 13.9 amperes at 120 volts (domestic USA models).

9. Limit Switch

The limit switch is a safety switch and is mounted in the heating element frame. It will open and break the circuit on temperature rise in case the air flow through the heater becomes low enough to cause the heater to overheat.

10. Run Capacitors

The purpose of the run capacitors is to give the motors starting torque and to maintain high power factor during running. The run capacitors are always connected between the start and run or main terminals of the motor.

Capacitor Check

There are several capacitor test devices available. The ohm meter is one of them. The ohm meter cannot verify a capacitor's MFD (microfarad) value. However, the following procedures will show you how to use an ohm meter to determine if the capacitor is good, open, shorted or grounded.

Before testing any capacitor, always perform the following procedure:

- a) Disconnect all electrical power to the air conditioner.
- b) Discharge the capacitor with a 20,000 ohm (approx. 3 watt) resistor or larger.
- c) You may discharge capacitors with a standard volt meter if you use a scale over 500 volts and touch the leads (one lead to each side of the capacitor), the volt meter will discharge the capacitor.
- d) Identify and disconnect the wiring from the capacitor.
- e) Set and zero the ohm meter on the "highest" scale.

When testing for a good, open or shorted capacitor, perform the following checks: Place the ohm meter leads across the capacitor terminals (one lead on each terminal) and perform a continuity test. Then observe the action of the meter needle or indicator. Reverse the leads and test again. The result should be the same. Note: If the capacitor had not been properly discharged, a false reading could be indicated on the first test. Always test several times (reversing the leads with each test). This will verify the capacitor's condition.

Good Capacitor

If the capacitor is good, the indicator will move from infinity (the left side), up towards zero ohms and slowly return back to infinity. Reverse the leads and test again. The result should be the same.

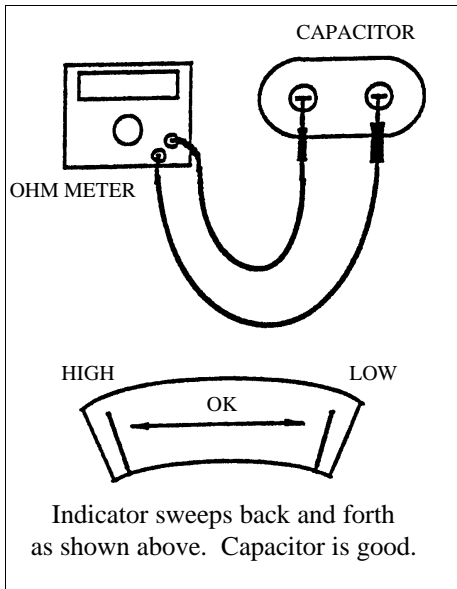

Open Capacitor

If the capacitor is open, the indicator will show no deflection or movement. Reverse the leads and test again. If there is no indicator movement on the second test, the capacitor is open. Open capacitors are defective and must be replaced.

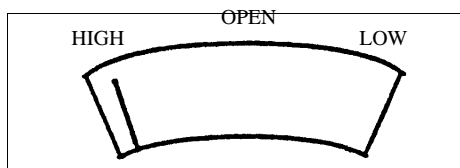

Indicator shows no movement. Needle stays to the left side. If needle shows no movement after reversing the leads, the capacitor is open.

Shorted Capacitor

If the capacitor is shorted, the indicator will move toward and sometimes hit zero ohms, and will stay there. This indicates a completed circuit through the inside of the capacitor (shorted). Shorted capacitors are defective and must be replaced.

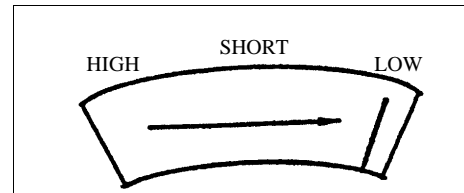

Indicator moves to the right side of the scale and stays there (indicating a completed circuit). The capacitor is shorted.

Grounded Capacitor

When testing for a grounded capacitor, perform a continuity check between each terminal on the capacitor and the bare metal of the capacitor case. Any indication of a circuit (constant resistance) from either terminal to case, indicates a grounded capacitor. Grounded capacitors are defective and must be replaced.

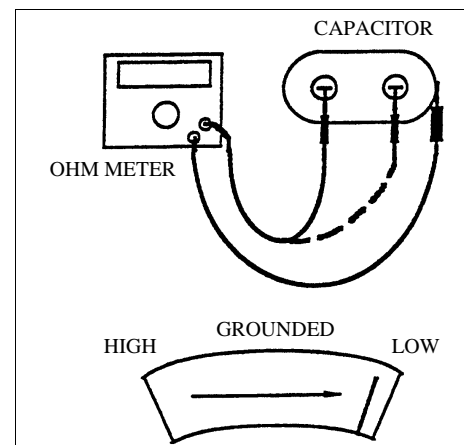

Indicator moves to the right side of the scale and stays there (indicating a completed circuit). The capacitor is grounded.

11. Start Capacitor

Some models use a start capacitor and a start relay to give the compressor high starting torque. The compressor will, therefore, start against normal pressure differences (head pressure minus suction pressure) even when shut down for a short period of time. The start relay will disconnect the start

capacitor when the motor reaches approximately 75% running speed.

Notice the resistor which is soldered to the terminals of the start capacitor. The resistor is there to discharge the capacitor after the relay disconnects it from the circuit. This resistor must be in place or the capacitor will discharge through the relay when the compressor is shut down and in doing so, will damage the relay contacts.

12. Start (Potential) Relay

The start relay consists of –

- 1) Normally closed contacts internally between terminals #1 and #2 which switch in the start capacitor in parallel to the run capacitor during shutdown and then switch out the start capacitor when the motor reaches approximately 75% normal running speed.

- 2) A high voltage coil internally between terminals #5 and #2 to actuate the contacts. The coil is too weak on line voltage to actuate the contacts, but it is connected in series with the start winding and it gets the generated voltage of the start winding portion of the compressor motor. This generated voltage is much higher than line voltage and varies with the speed of the motor. Therefore, since the relay is designed to open the contacts at 75% of normal running voltage (measured between terminals #5 and #2), the contacts will open (thus disconnect the start capacitor) at approximately 75% of normal running speed.

13. Thermister

The thermister is a freeze protection device installed in the compressor relay circuit to prevent evaporator coil freeze-ups. This device is a semi-conductor which has electrical resistance that varies with temperature. The thermister cutout temperature is $31^{\circ}\text{F} \pm 3^{\circ}$ and reset temperature is 53°F .

IX. ELECTRICAL FLOW CHARTS

Nothing Runs

Thermostat In Cooling Mode And Turned Down So That It Will Be Calling For Cooling

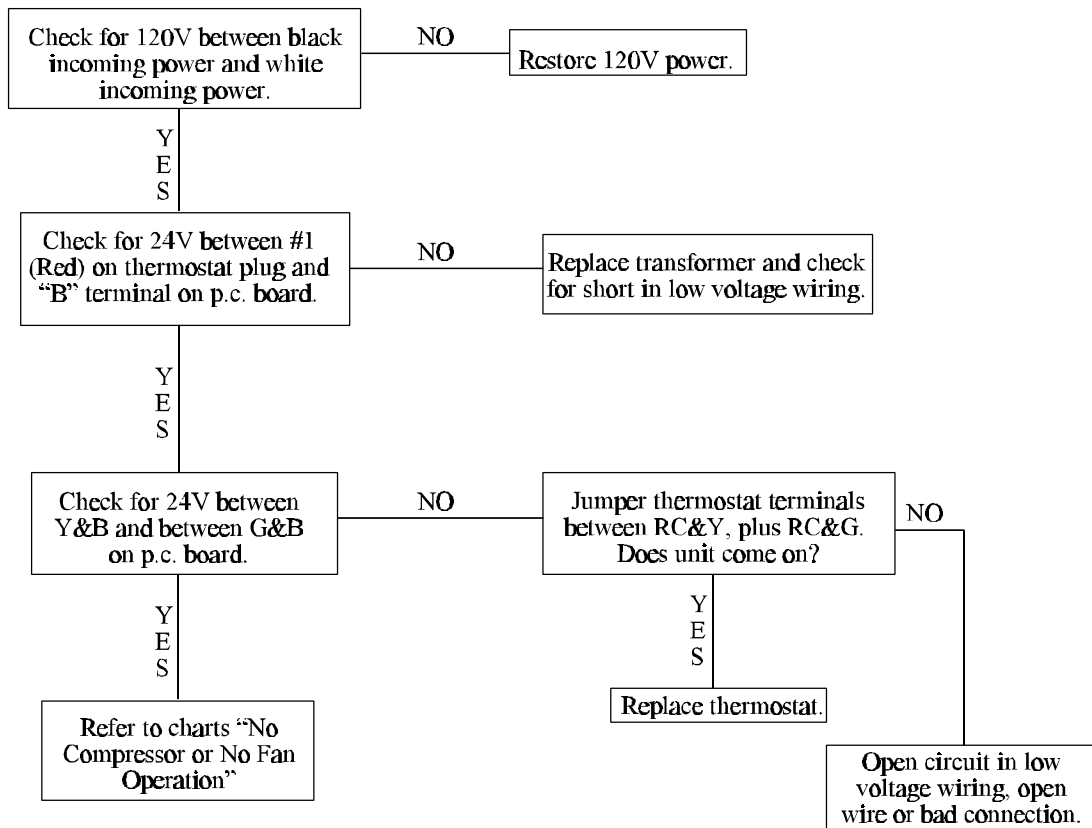

Fan Runs - No Compressor

Turn Thermostat To Cool And Turn Temperature Down So That The Thermostat Should Be Calling For Cooling

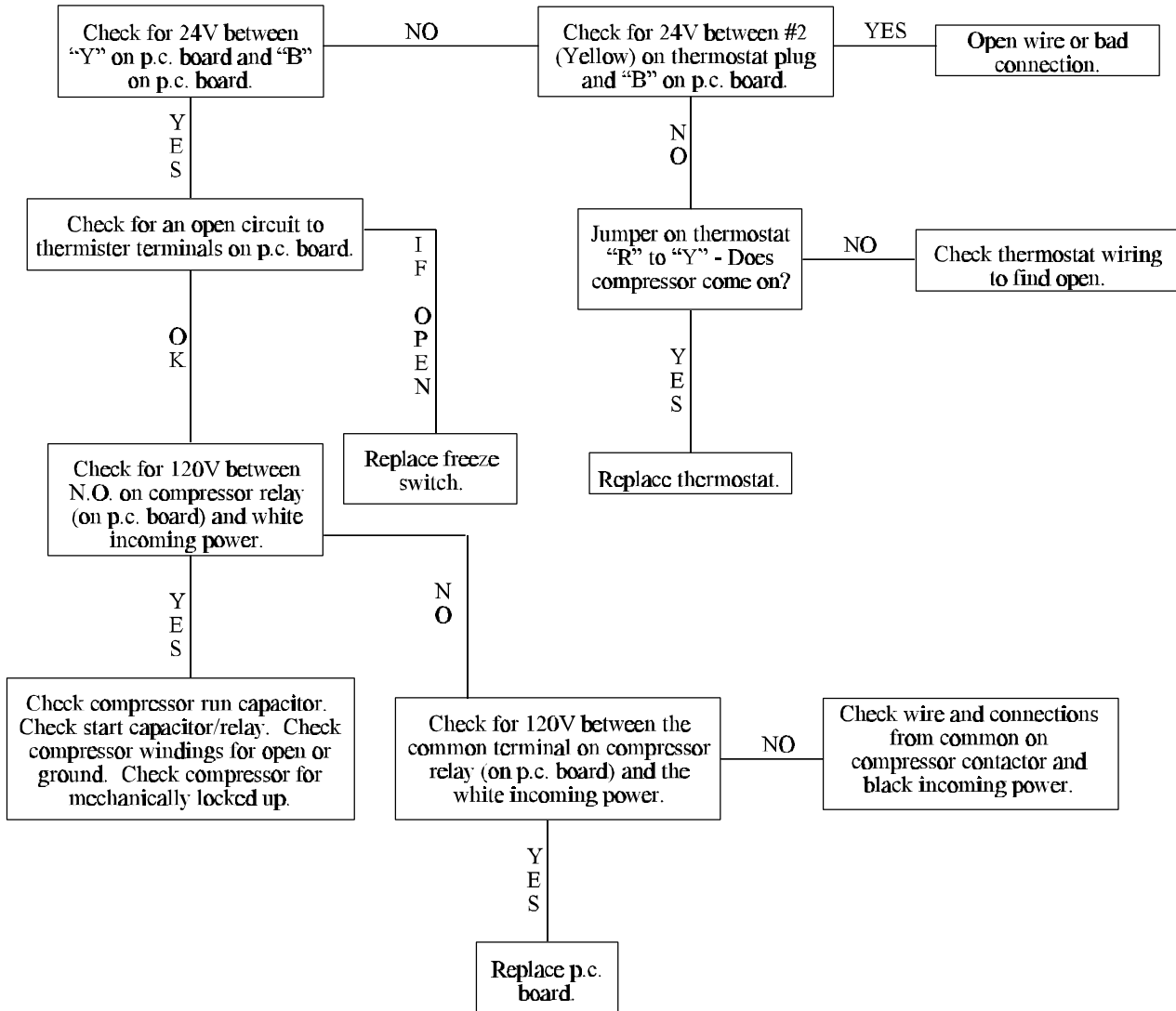

Compressor Runs - No Fan

Thermostat In Cooling Mode And Turned Down So That It Will Be Calling For Cooling

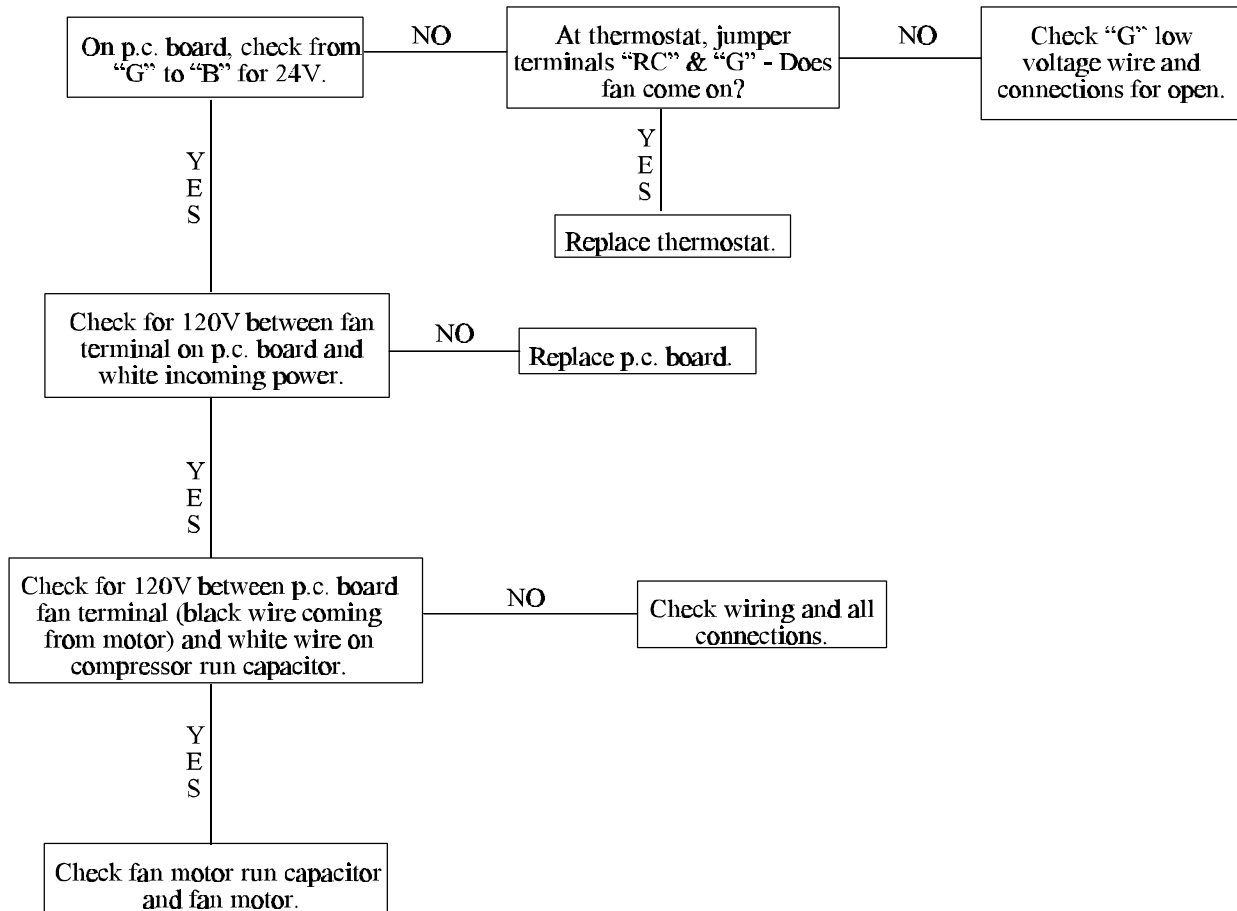

Fan Runs - No Heat

**Thermostat In Heating Mode and Turned Up So That
It Will Be Calling For Heat**

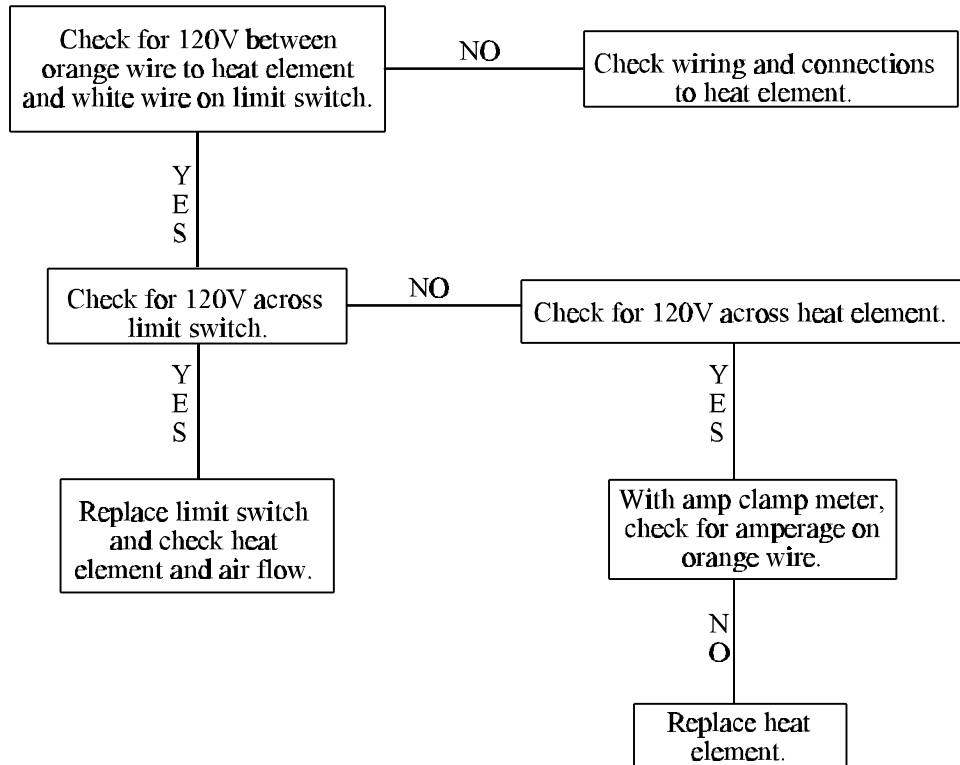

Heat Runs - No Fan

Thermostat In Heating Mode And Turned Up So That It Will Be Calling For Heat

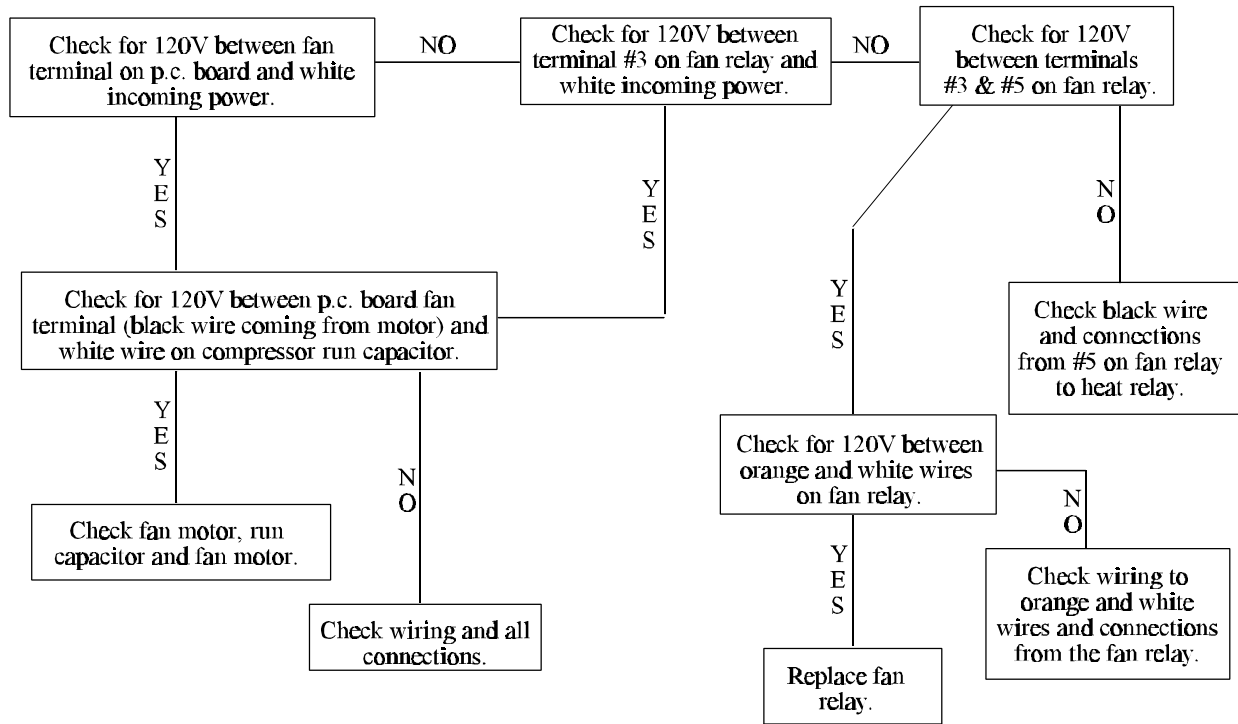

X. WIRING DIAGRAM

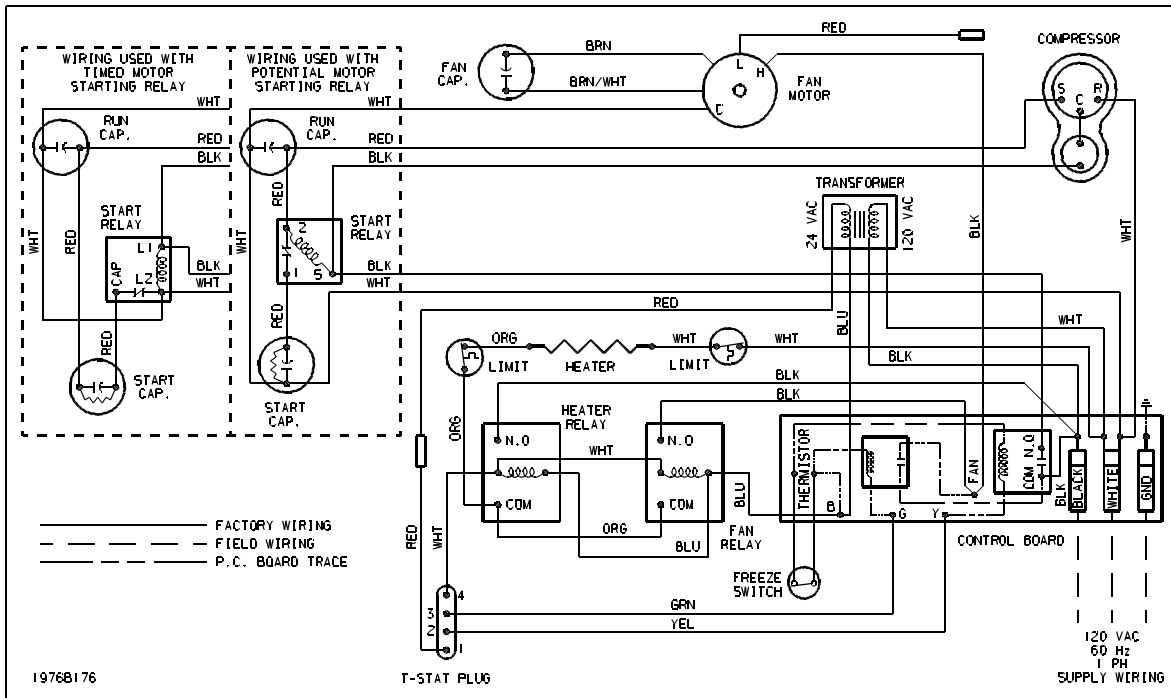



RV Products
A Division of Airxcel, Inc.
P.O. Box 4020
Wichita, KS 67204

